

Si5XX SINGLE/DUAL FREQUENCY XO/VCXO EVALUATION BOARD

Description

The Silicon Laboratories Si5xx evaluation board contains the hardware needed for evaluation of the Si5xx Single/Dual Frequency XO/VCXO.

Note: The Si5xx-EVB is not populated with an Si5xx XO or VCXO. These devices must be ordered separately. Go to www.silabs.com/VCXOPartnumber to configure a device and/or to order samples.

Features

- Evaluation of Silicon Laboratories' Si5xx Single/Dual Frequency XO/VCXO
- Voltage control (VC) input port (Si515, Si516)
- Supports frequencies up to 1.4 GHz (using Si53x/55x)
- Dual footprint supports 3.2 x 5 or 5 x 7 mm

Function Block Diagram

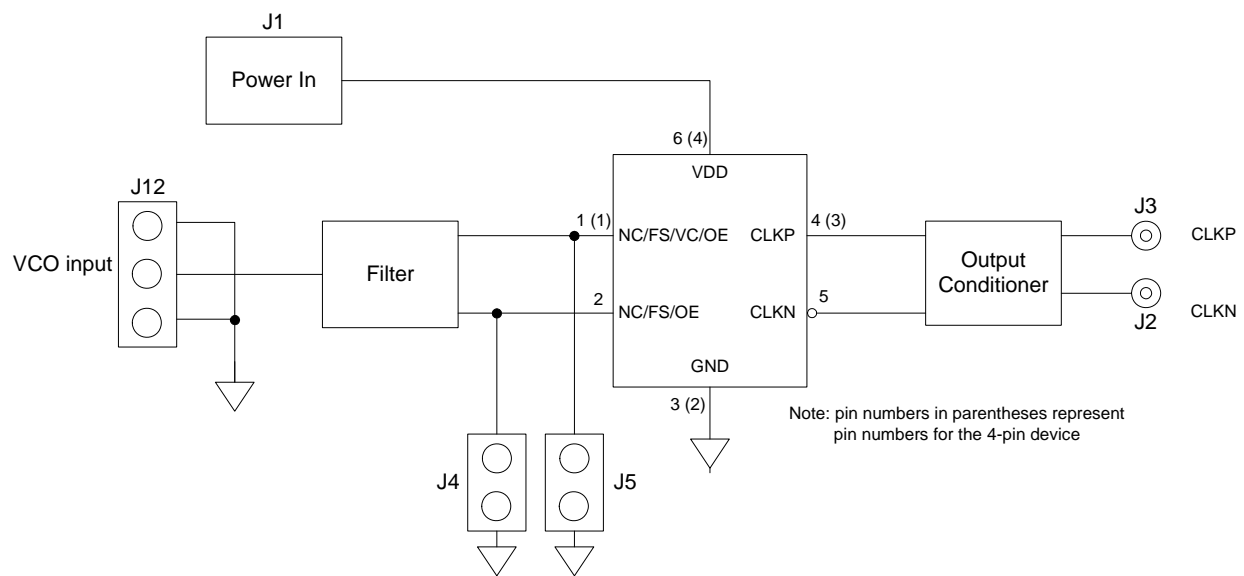

Si5xx-EVB

1. Introduction

This document describes the operation of the Silicon Laboratories Si5xx evaluation kit. The Si5xx-EVB kit refers to the evaluation board hardware intended for customer evaluation of the Si5xx single/dual frequency XO/VCXO. The Si5xx-EVB kit contains the following:

- Si5xx-EVB Hardware
- Si5xx-EVB User Guide (this document)

The Si5xx-EVB evaluation board can be used to evaluate all the single and dual frequency Si5xx XO/VCXOs offered by Silicon Laboratories:

Table 1. Si5xx XO and VCXO Device Evaluation Board Selector Guide

Part #	Type	Devices Supported	Packages Supported	Output Format, Temp Stability, Tuning Slope	Supported Frequency Range
Si5XX-EVB	Fixed Frequency XO/VCXO Eval Board	Si510/511 Si512/513 Si515/516 Si530/531 Si532/533 Si535/536 Si550/552 Si590/591	5 x 7 mm, 6-pin 3.2 x 5 mm, 6-pin 3.2 x 5 mm, 4-pin	LVPECL CML HCSL LVDS CMOS Dual-CMOS	100 kHz to 1417 MHz

Note: Si5xx samples must be ordered separately from the Si5xx-EVB.

1.1. Quick Start

1. Install an Si5xx device on the board.
2. Verify the jumper settings are correct.
3. Connect external power cable to the EVB (set voltage according to how the part was ordered).

2. Top/Bottom Views of Board

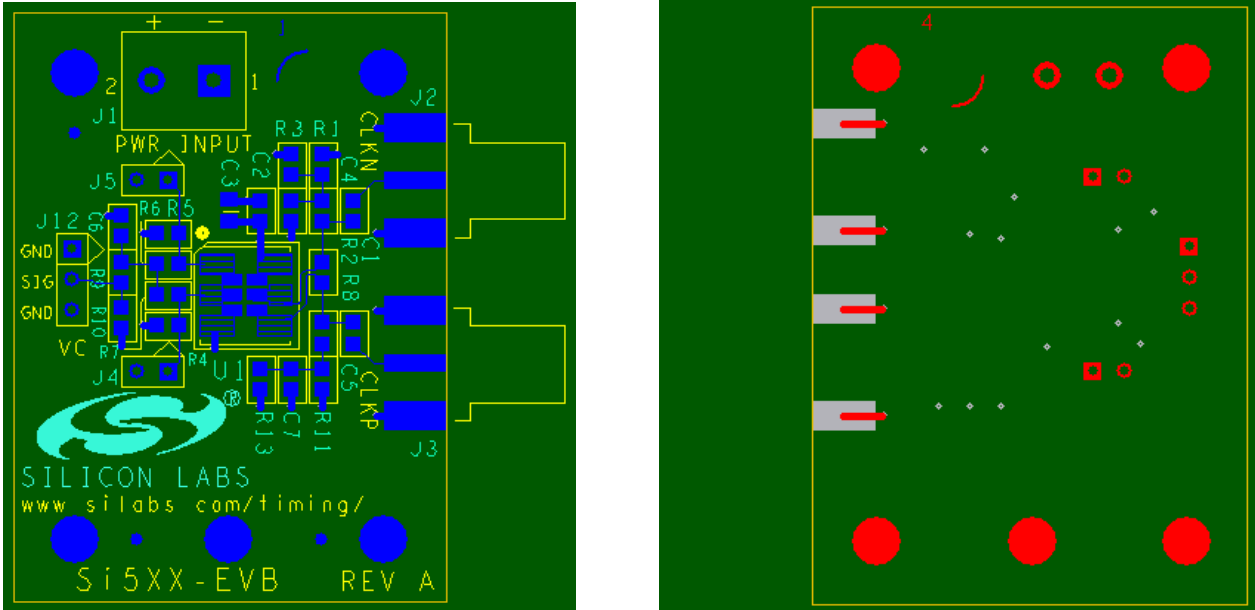

Figure 1. Top (Left) and Bottom (Right) Board Views

Si5xx-EVB

3. Functional Description

The Si5xx-EVB is the evaluation board assembly for the Si5xx single/dual frequency XO/VCO. This evaluation board assembly provides access to all signals for operating the device. The Si5xx-EVB schematics, bill of material, and PCB layouts are included as sections 4, 5, and 6, respectively. Figure 2 provides a block diagram for the board.

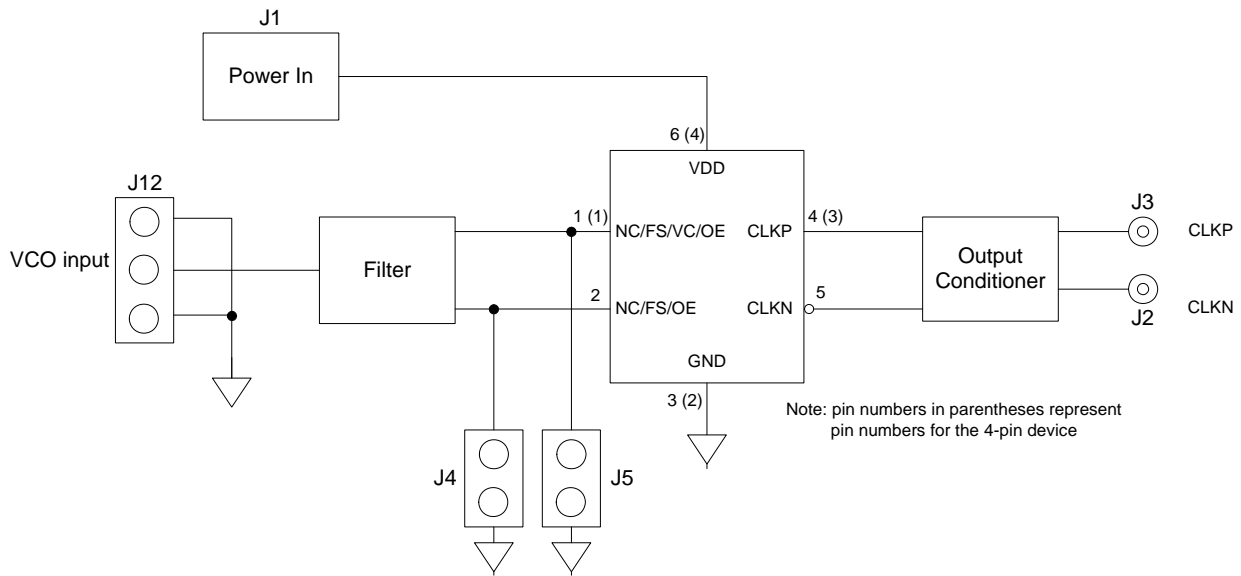

Figure 2. Si5xx-EVB Functional Block Diagram

3.1. Power Supply

The Si5xx-EVB accepts either an external supply of 1.8, 2.5, or 3.3 V at connector J1. (Insure the voltage range of the DUT is obeyed, and it is also good practice to set a current limit on the power supply).

3.2. Jumpers

There are two jumpers on the Si5xx-EVB as listed in Table 2. The board default is to have no jumpers.

Table 2. Si5xx-EVB Jumpers

Component	Si510	Si511	Si512	Si513	Si515	Si516
R6	remove	remove	remove	remove	installed	installed
R7	remove	remove	remove	remove	remove	remove
J4	No jumper: OE = Hi Jumper: OE = Lo	No jumper	No jumper: OE = Hi Jumper: OE = Lo	No jumper: FS = Hi Jumper: FS = Lo	No jumper: OE = Hi Jumper: OE = Lo	No jumper: FS = Hi Jumper: FS = Lo
J5	No jumper	No jumper: OE = Hi Jumper: OE = Lo	No jumper: FS = Hi Jumper: FS = Lo	No jumper: OE = Hi Jumper: OE = Lo	No jumper	No jumper

3.3. Si5xx-EVB Voltage Control Signal

An external voltage control signal may be applied to the control voltage modulation input at the J12 header (VC). This voltage supplies the control voltage or voltage modulation input to the DUT. See Section 3.2 on how to configure the jumpers and VC enable resistors (R6 and R7).

3.4. Output Terminations

The Si5xx-EVB can support four different output formats: CMOS, LVPECL, LVDS, and HCSL. There are output resistors that are needed to accompany each format. Table 3 shows which resistors are needed for each output:

Table 3. Output Termination Installation Definition

Output Format	R2	R12	R8	R1	R11	R3	R13	C1	C7
CMOS	NP	NP	NP	NP	NP	82	82	100N	100N
LVPECL	0	0	NP	NP	NP	130	130	NP	NP
LVDS	NP	NP	NP	NP	NP	82	82	100N	100N
HCSL	NP	NP	NP	NP	NP	82	82	100N	100N

Si5xx-EVB

4. Configuring the Si5xx-EVB

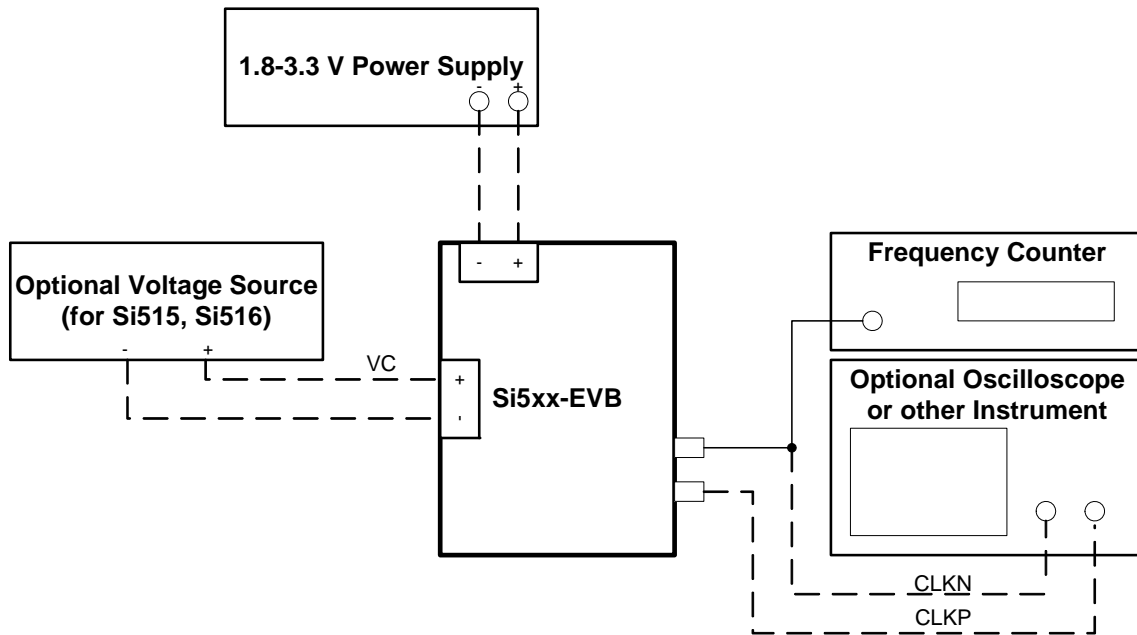

Figure 3. Si5xx-EVB Typical Configuration

5. Schematic

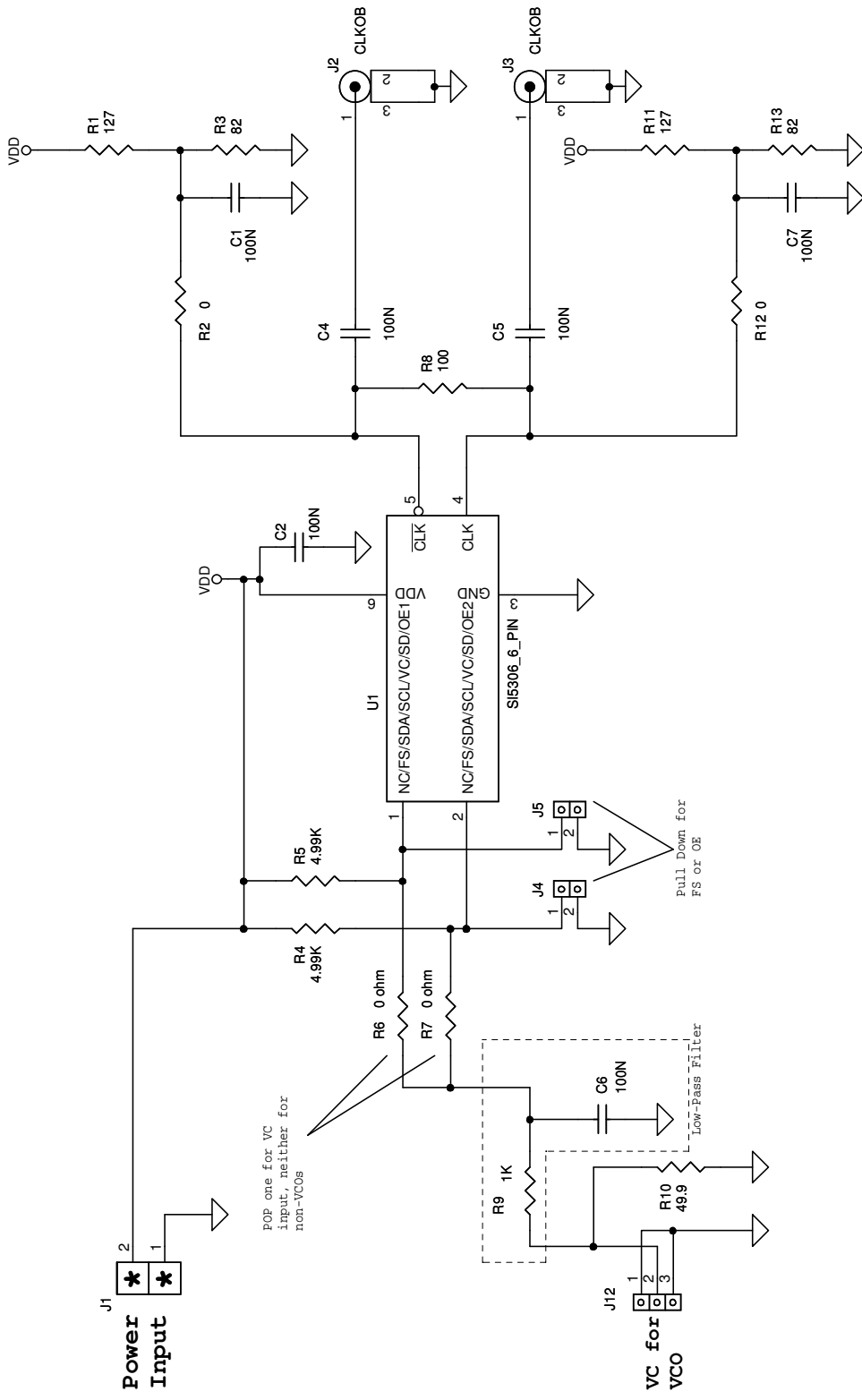

Figure 4. Si5xx-EVB Schematic

Si5xx-EVB

6. Bill of Materials

Table 4. Si5xx-EVB Bill of Materials

Item	Catty	Reference	Value	Mfr	Manufacturer PN	PCB Footprint
1	6	C1,C2,C4,C5,C6,C7	100N	Venkel	C0603X7R160-104KNE	SM_C_0603
2	1	J1	Phoenix-2_screw	Phoenix	MKDSN 1.5/2-5.08	Phoenix2pinM_p2pitch
3	2	J2,J3	edge mount sma	Johnson	142-0701-801	SMA_EDGE_p062
4	2	J4,J5	1by2_M_Hdr	Salines	Don't care	Thru-hole, .1" pitch
5	1	J12	Jmpr_3pin	Tyco	146225-3	3pin_p1pitch
6	2	R1, R11	127	Venkel	CR0603-16W-127FT	SM_R_0603
7	2	R3, R13	82	Venkel	CR0603-16W-82R0FT	SM_R_0603
8	4	R2, R6, R7, R12	0 ohm	Venkel	CR0603-16W-000T	SM_R_0603
9	1	R10	49.9	Venkel	CR0603-16W-49R9FT	SM_R_0603
10	2	R4,R5	4.99K	Venkel	CR0603-16W-4991FT	SM_R_0603
11	1	R8	100	Venkel	CR0603-16W-1000FT	SM_R_0603
12	1	R9	1K	Venkel	CR0603-16W-1001FT	SM_R_0603
No Pop						
13	0	U1	Si53x	SiLABS	N/A	6_pin_SM
14	0	C3	10UF	Venkel	C0805X5R6R3-106KNE	SM_C_0805

7. Layout

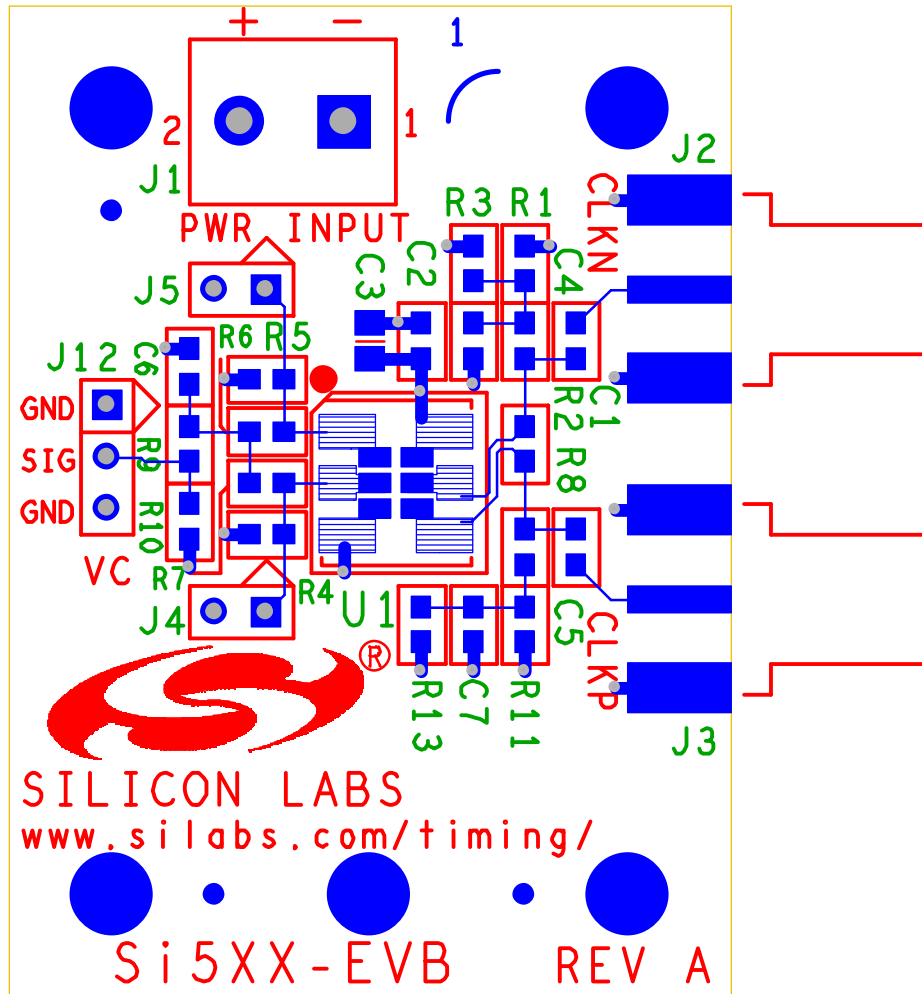

Figure 5. Layer 1: Primary Side

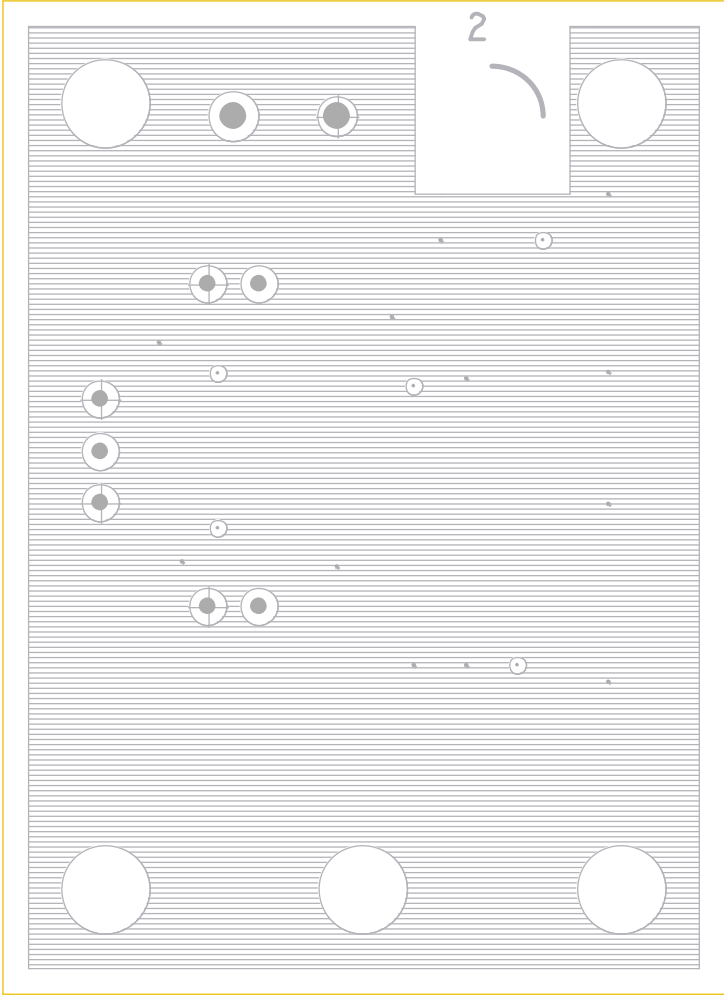

Figure 6. Layer 2: GND

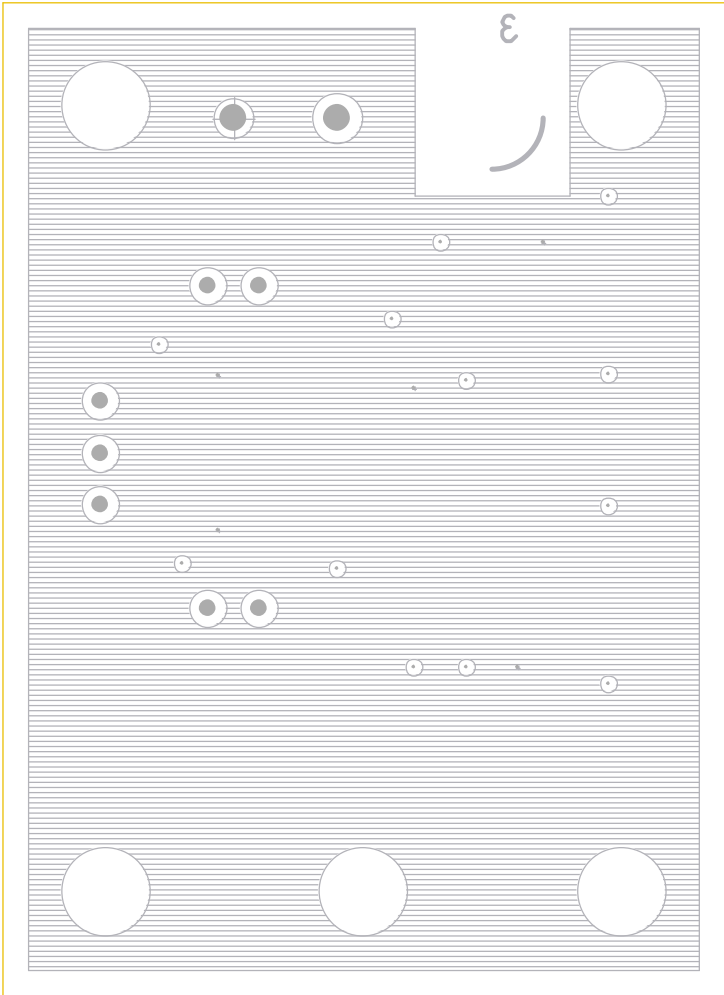

Figure 7. Layer 4: PWR

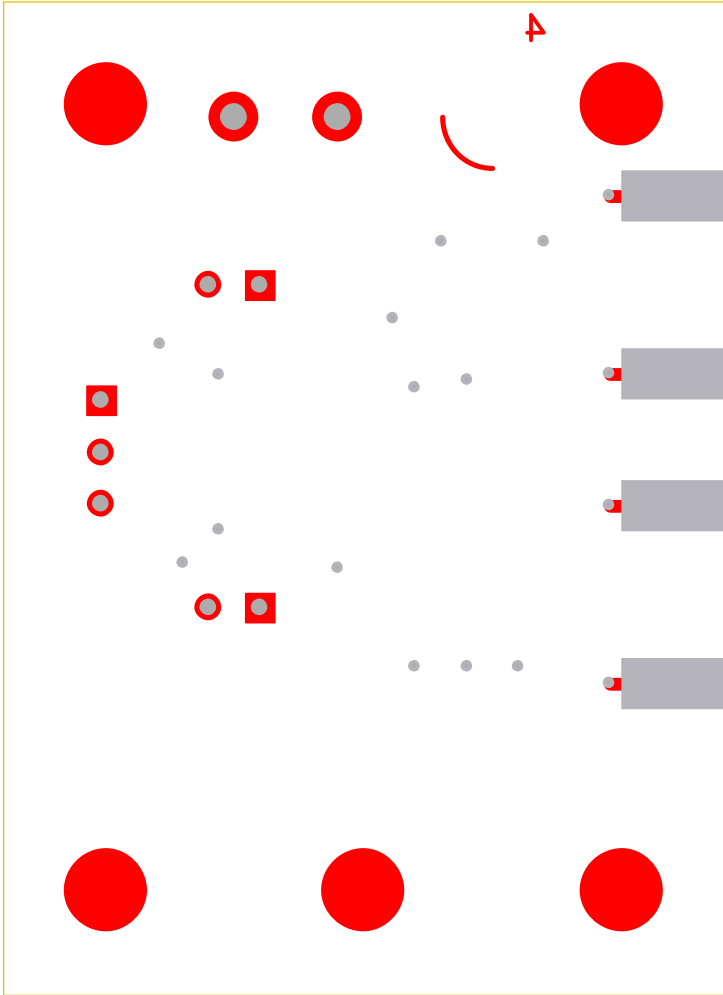

Figure 8. Layer 4: Secondary Side

Document Change List

Revision 0.1 to Revision 0.2

- Added Si535/536 part numbers to Table 1.



ClockBuilder Pro

One-click access to Timing tools, documentation, software, source code libraries & more. Available for Windows and iOS (CBGo only).

www.silabs.com/CBPro



Timing Portfolio
www.silabs.com/timing



SW/HW
www.silabs.com/CBPro



Quality
www.silabs.com/quality



Support and Community
community.silabs.com

Disclaimer

Silicon Labs intends to provide customers with the latest, accurate, and in-depth documentation of all peripherals and modules available for system and software implementers using or intending to use the Silicon Labs products. Characterization data, available modules and peripherals, memory sizes and memory addresses refer to each specific device, and "Typical" parameters provided can and do vary in different applications. Application examples described herein are for illustrative purposes only. Silicon Labs reserves the right to make changes without further notice to the product information, specifications, and descriptions herein, and does not give warranties as to the accuracy or completeness of the included information. Without prior notification, Silicon Labs may update product firmware during the manufacturing process for security or reliability reasons. Such changes will not alter the specifications or the performance of the product. Silicon Labs shall have no liability for the consequences of use of the information supplied in this document. This document does not imply or expressly grant any license to design or fabricate any integrated circuits. The products are not designed or authorized to be used within any FDA Class III devices, applications for which FDA premarket approval is required or Life Support Systems without the specific written consent of Silicon Labs. A "Life Support System" is any product or system intended to support or sustain life and/or health, which, if it fails, can be reasonably expected to result in significant personal injury or death. Silicon Labs products are not designed or authorized for military applications. Silicon Labs products shall under no circumstances be used in weapons of mass destruction including (but not limited to) nuclear, biological or chemical weapons, or missiles capable of delivering such weapons. Silicon Labs disclaims all express and implied warranties and shall not be responsible or liable for any injuries or damages related to use of a Silicon Labs product in such unauthorized applications.

Trademark Information

Silicon Laboratories Inc.®, Silicon Laboratories®, Silicon Labs®, SiLabs® and the Silicon Labs logo®, Bluegiga®, Bluegiga Logo®, ClockBuilder®, CMEMS®, DSPLL®, EFM®, EFM32®, EFR®, Ember®, Energy Micro, Energy Micro logo and combinations thereof, "the world's most energy friendly microcontrollers", Ember®, EZLink®, EZRadio®, EZRadioPRO®, Gecko®, Gecko OS, Gecko OS Studio, ISOModem®, Precision32®, ProSLIC®, Simplicity Studio®, SiPHY®, Telegesis, the Telegesis Logo®, USBXpress®, Zentri, the Zentri logo and Zentri DMS, Z-Wave®, and others are trademarks or registered trademarks of Silicon Labs. ARM, CORTEX, Cortex-M3 and THUMB are trademarks or registered trademarks of ARM Holdings. Keil is a registered trademark of ARM Limited. Wi-Fi is a registered trademark of the Wi-Fi Alliance. All other products or brand names mentioned herein are trademarks of their respective holders.



Silicon Laboratories Inc.
400 West Cesar Chavez
Austin, TX 78701
USA

<http://www.silabs.com>