



2.5-V/3.3-V OSCILLATOR GAIN STAGE/BUFFERS

FEATURES

- Low-Voltage PECL Input and Low-Voltage PECL or LVDS Outputs
- Clock Rates to 1 GHz
 - 250-ps Output Transition Times
 - 0.12 ps Typical Intrinsic Phase Jitter
 - Less than 630 ps Propagation Delay Times
- 2.5-V or 3.3-V Supply Operation

- 2-mm x 2-mm Small-Outline No-Lead Package

APPLICATIONS

- PECL-to-LVDS Translation
- Clock Signal Amplification

DESCRIPTION

These four devices are high frequency oscillator gain stages supporting both LVPECL or LVDS on the high gain outputs in 3.3-V or 2.5-V systems. Additionally, provides the option of both single-ended input (PECL levels on the SN65LVx18) and fully differential inputs on the SN65LVx19.

The SN65LVx18 provides the user a Gain Control (GC) for controlling the \bar{Q} output from 300 mV to 860 mV either by leaving it open (NC), grounded, or tied to V_{CC} . (When left open, the \bar{Q} output defaults to 575 mV.) The \bar{Q} on the SN65LVx19 defaults to 575 mV as well.

Both devices provide a voltage reference (V_{BB}) of typically 1.35 V below V_{CC} for use in receiving single-ended PECL input signals. When not used, V_{BB} should be unconnected or open.

All devices are characterized for operation from -40°C to 85°C .

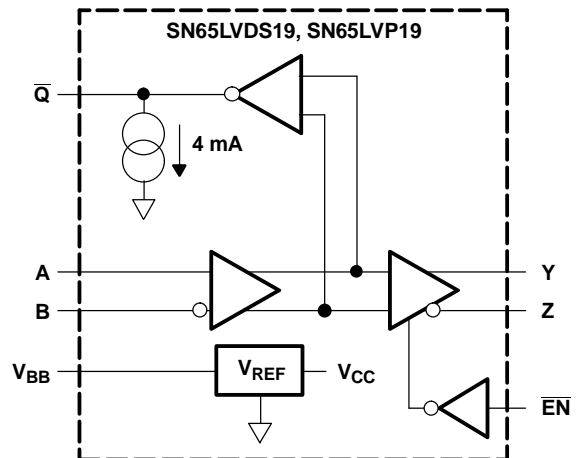
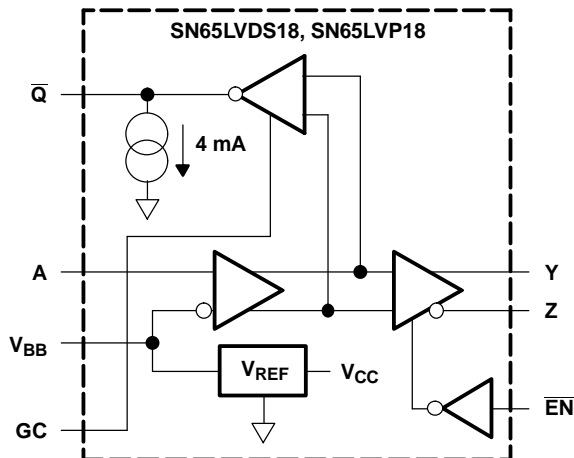

Please be aware that an important notice concerning availability, standard warranty, and use in critical applications of Texas Instruments semiconductor products and disclaimers thereto appears at the end of this data sheet.



These devices have limited built-in ESD protection. The leads should be shorted together or the device placed in conductive foam during storage or handling to prevent electrostatic damage to the MOS gates.

AVAILABLE OPTIONS⁽¹⁾

INPUT	OUTPUT	GAIN CONTROL	BASE PART NUMBER	PART MARKING
Single-ended	LVDS	Yes	SN65LVDS18	ER
Single-ended	LVPECL	Yes	SN65LVP18	EP
Differential	LVDS	No	SN65LVDS19	ET
Differential	LVPECL	No	SN65LVP19	ES

(1) For the most current package and ordering information, see the Package Option Addendum at the end of this document, or see the TI website at www.ti.com.

ABSOLUTE MAXIMUM RATINGS

over operating free-air temperature range (unless otherwise noted) ⁽¹⁾

	UNIT
V_{CC} Supply voltage ⁽²⁾	-0.5 V to 4 V
V_I Input voltage	-0.5 V to $V_{CC} + 0.5$ V
V_O Output voltage	-0.5 V to $V_{CC} + 0.5$ V
I_O V_{BB} output current	±0.5 mA
HBM electrostatic discharge ⁽³⁾	±3 kV
CDM electrostatic discharge ⁽⁴⁾	±1500 V
Continuous power dissipation	See Power Dissipation Ratings Table

(1) Stresses beyond those listed under "absolute maximum ratings" may cause permanent damage to the device. These are stress ratings only and functional operation of the device at these or any other conditions beyond those indicated under "recommended operating conditions" is not implied. Exposure to absolute-maximum-rated conditions for extended periods may affect device reliability.

(2) All voltage values, except differential voltages, are with respect to network ground (see Figure 1).

(3) Tested in accordance with JEDEC Standard 22, Test Method A114-A-7

(4) Tested in accordance with JEDEC Standard 22, Test Method C101

DISSIPATION RATINGS

PACKAGE	$T_A < 25^\circ\text{C}$ POWER RATING	OPERATING FACTOR ABOVE $T_A = 25^\circ\text{C}$	$T_A = 85^\circ\text{C}$ POWER RATING
DRF	403 mW	4.0 mW/°C	161 mW

RECOMMENDED OPERATING CONDITIONS

		MIN	NOM	MAX	UNIT
V_{CC} Supply Voltage		2.375	2.5 or 3.3	3.6	V
V_{IC} Common-mode input voltage $(V_{IA} + V_{IB})/2$	SN65LVDS19 or SN65LVP19	1.2		$V_{CC} - (V_{ID}/2)$	V
$ V_{ID} $ Differential input voltage magnitude $ V_{IA} - V_{IB} $	SN65LVDS19 or SN65LVP19	0.8		1	V
V_{IH} High-level input voltage	\overline{EN}	2		V_{CC}	V
	SN65LVDS18 or SN65LVP18	$V_{CC} - 1.17$		$V_{CC} - 0.44$	
V_{IL} Low-level input voltage	\overline{EN}	0		0.8	V
	SN65LVDS18 or SN65LVP18	$V_{CC} - 2.25$		$V_{CC} - 1.52$	
I_O Output current to V_{BB}		-400 ⁽¹⁾		400	μA
R_L Differential load resistance		90		132	Ω
T_A Operating free-air temperature		-40		85	°C

(1) The algebraic convention, where the least positive (more negative) value is designated minimum, is used in this data sheet.

ELECTRICAL CHARACTERISTICS

over recommended operating conditions (unless otherwise noted)

PARAMETER	TEST CONDITIONS	MIN	TYP ⁽¹⁾	MAX	UNIT	
I _{CC}	Supply current	R _L = 100 Ω, \overline{EN} at 0 V, Other inputs open	30	36	mA	
		Outputs unloaded, \overline{EN} at 0 V, Other inputs open	17	22		
V _{BB}	Reference voltage ⁽²⁾	I _{BB} = -400 μA	V _{CC} - 1.44	V _{CC} - 1.35	V _{CC} - 1.25	V
I _{IH}	High-level input current, \overline{EN}	V _I = 2 V	-20	20	μA	
I _{IAH} or I _{IBH}	High-level input current, A or B	V _I = V _{CC}	-20	20		
I _{IL}	Low-level input current, \overline{EN}	V _I = 0.8 V	-20	20		
I _{IAL} or I _{IBL}	Low-level input current, A or B	V _I = GND	-20	20		
SN65LVDS18/19 Y AND Z OUTPUT CHARACTERISTICS						
V _{OD}	Differential output voltage magnitude, V _{OY} - V _{OZ}		247	340	454	mV
Δ V _{OD}	Change in differential output voltage magnitude between logic states	See Figure 1 and Figure 2			50	
V _{OC(SS)}	Steady-state common-mode output voltage (see Figure 3)		1.125	1.375		V
ΔV _{OC(SS)}	Change in steady-state common-mode output voltage between logic states	See Figure 3	-50	50		mV
V _{OC(PP)}	Peak-to-peak common-mode output voltage			50	100	
I _{OYZ} or I _{OZZ}	High-impedance output current	\overline{EN} at V _{CC} , V _O = 0 V or V _{CC}	-1		1	μA
I _{OYS} or I _{OZS}	Short-circuit output current	\overline{EN} at 0 V, V _{OY} or V _{OZ} = 0 V	-50		50	mA
I _{OS(D)}	Differential short-circuit output current, I _{OY} - I _{OZ}	\overline{EN} at 0 V, V _{OY} = V _{OZ}	-12		12	
SN65LVP18/19 Y AND Z OUTPUT CHARACTERISTICS						
V _{OYH} or V _{OZH}	High-level output voltage	3.3 V; 50 Ω from Y and Z to V _{CC} - 2 V	V _{CC} - 1.13		V _{CC} - 0.85	V
V _{OYL} or V _{OZL}	Low-level output voltage		V _{CC} - 1.87		V _{CC} - 1.61	
V _{OYL} or V _{OZL}	Low-level output voltage	2.5 V; 50 Ω from Y and Z to V _{CC} - 2 V	V _{CC} - 1.92		V _{CC} - 1.61	
V _{OD}	Differential output voltage magnitude, V _{OH} - V _{OL}		0.6	0.8	1	
I _{OYZ} or I _{OZZ}	High-impedance output current	\overline{EN} at V _{CC} , V _O = 0 V or V _{CC}	-1		1	μA
Q̄ OUTPUT CHARACTERISTICS (see Figure 1)						
V _{OH}	High-level output voltage	No load		V _{CC} - 0.94		V
V _{OL}	Low-level output voltage	GC Tied to GND, No load		V _{CC} - 1.22		V
		GC Open, No load		V _{CC} - 1.52		
		GC Tied to V _{CC} , No load		V _{CC} - 1.82		
V _{O(PP)}	Peak-to-peak output voltage	GC Tied to GND		300		mV
		GC Open		575		
		CGT Tied to V _{CC}		860		

(1) Typical values are at room temperature and with a V_{CC} of 3.3 V.

(2) Single-ended input operation is limited to V_{CC} ≥ 3.0 V.

SWITCHING CHARACTERISTICS

over recommended operating conditions (unless otherwise noted)

PARAMETER		TEST CONDITIONS	MIN	TYP ⁽¹⁾	MAX	UNIT
t _{PD}	Propagation delay time, t _{PLH} or t _{PHL}	A to \bar{Q}	See Figure 4	340	460	ps
		D to Y or Z		460	630	
t _{SK(P)}	Pulse skew, t _{PLH} - t _{PHL}				20	
t _{SK(PP)}	Part-to-part skew ⁽²⁾	V _{CC} = 3.3 V			80	ps
		V _{CC} = 2.5 V			130	
t _r	20%-to-80% differential signal rise time	LVDS, See Figure 4		140	250	ps
		LVPECL, See Figure 4		190	300	
t _f	20%-to-80% differential signal fall time	LVDS, See Figure 4		140	250	ps
		LVPECL, See Figure 4		210	300	
t _{jit(per)}	RMS period jitter ⁽³⁾	2-GHz 50%-duty-cycle square-wave input, See Figure 5		2	4	ps
t _{jit(cc)}	Peak cycle-to-cycle jitter ⁽⁴⁾			17	24	
t _{jit(ph)}	Intrinsic phase jitter	1 GHz		0.12		ps
t _{PHZ}	Propagation delay time, high-level-to-high-impedance output	See Figure 6			30	ns
t _{PLZ}	Propagation delay time, low-level-to-high-impedance output				30	
t _{PZH}	Propagation delay time, high-impedance-to-high-level output				30	
t _{PZL}	Propagation delay time, high-impedance-to-low-level output				30	

- (1) Typical values are at room temperature and with a V_{CC} of 3.3 V.
- (2) Part-to-part skew is the magnitude of the difference in propagation delay times between any specified terminals of two devices when both devices operate with the same supply voltages, at the same temperature, and have identical packages and test circuits.
- (3) Period jitter is the deviation in cycle time of a signal with respect to the ideal period over a random sample of 100,000 cycles.
- (4) Cycle-to-cycle jitter is the variation in cycle time of a signal between adjacent cycles, over a random sample of 1,000 adjacent cycle pairs.

PARAMETER MEASUREMENT INFORMATION

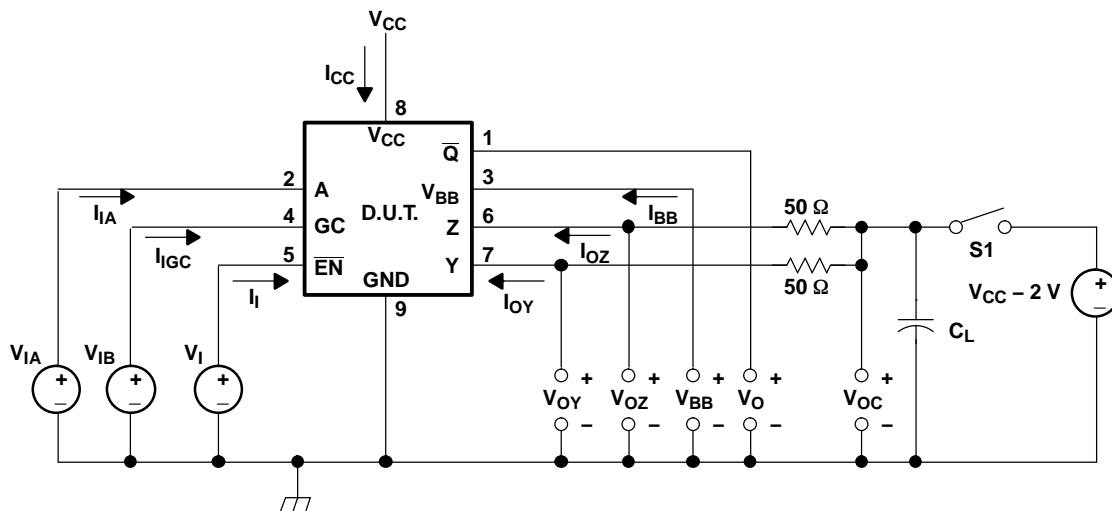

- (1) C_L is the instrumentation and test fixture capacitance.
- (2) S1 is open for the SN65LVDS18 and closed for the SN65LVP18.

Figure 1. Output Voltage Test Circuit and Voltage and Current Definitions for LVDS/LVP18

PARAMETER MEASUREMENT INFORMATION (continued)

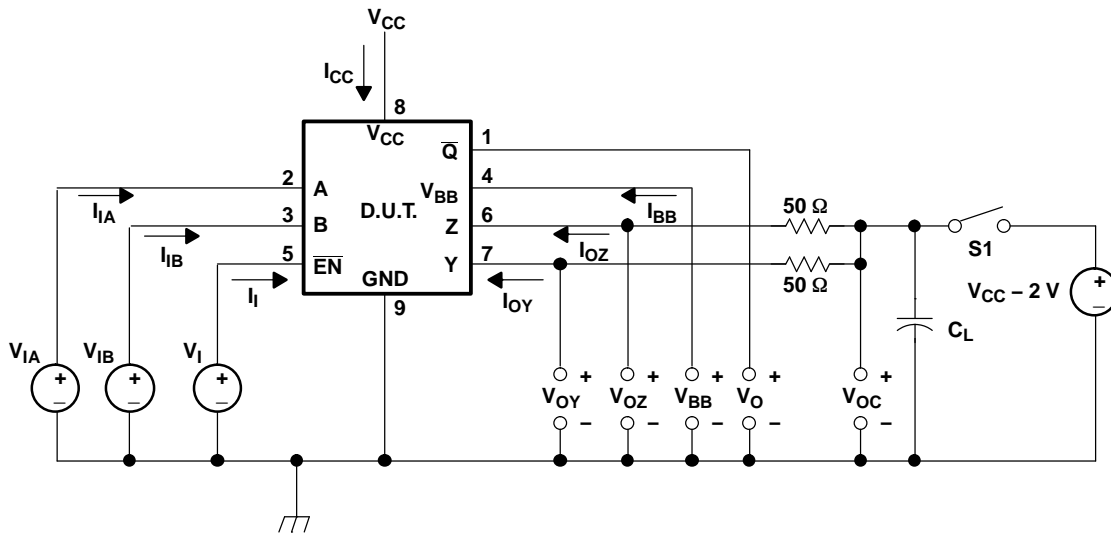

- (1) C_L is the instrumentation and test fixture capacitance.
- (2) S1 is open for the SN65LVDS19 and closed for the SN65LVP19.

Figure 2. Output Voltage Test Circuit and Voltage and Current Definitions for LVDS/LVP19

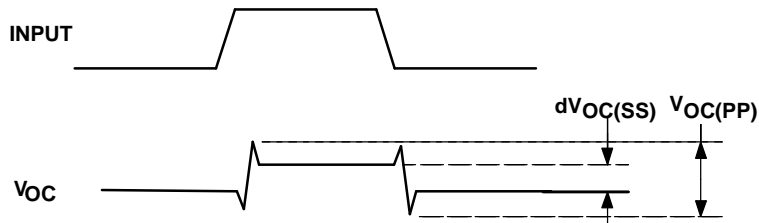

Figure 3. V_{OC} Definitions

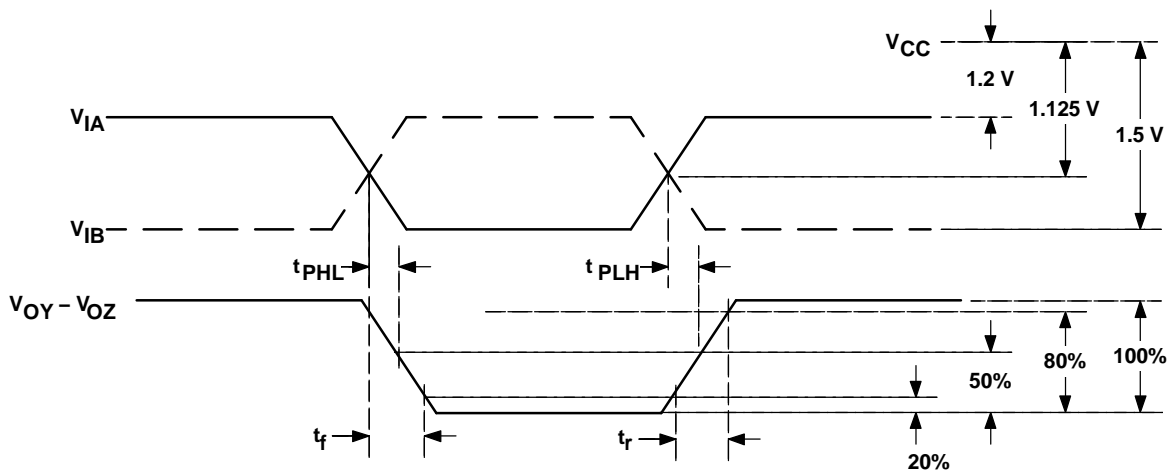

Figure 4. Propagation Delay and Transition Time Test Waveforms

PARAMETER MEASUREMENT INFORMATION (continued)

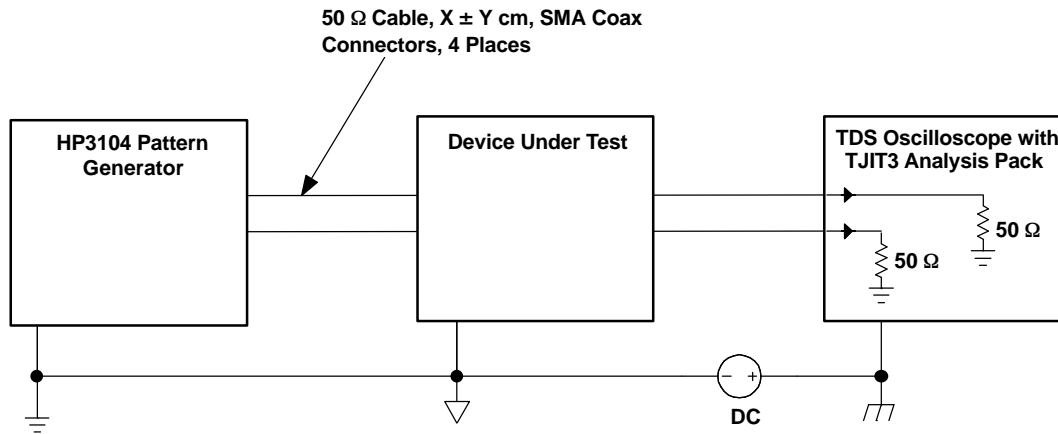

Figure 5. Jitter Measurement Setup

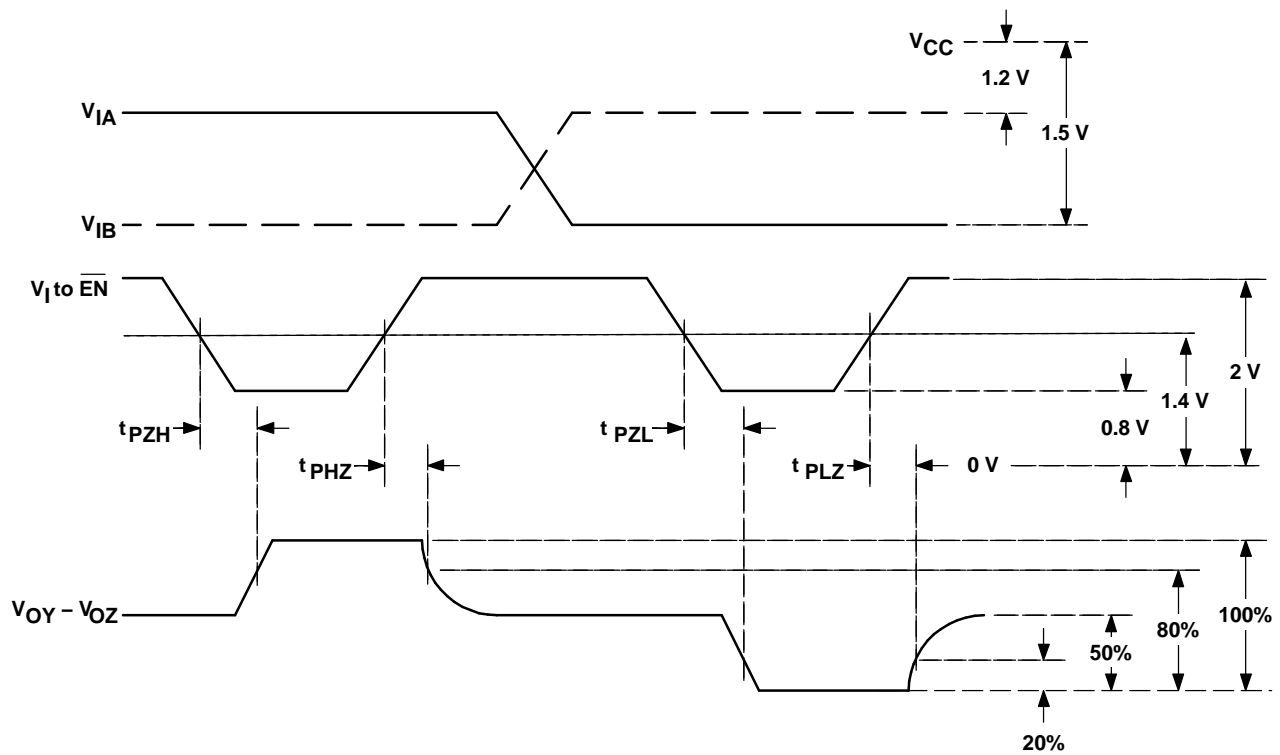

Figure 6. Enable and Disable Time Test Waveforms

DEVICE INFORMATION

FUNCTION TABLE (1)

SN65LVDS18, SN65LVP18					SN65LVDS19, SN65LVP19					
A	$\overline{\text{EN}}$	$\overline{\text{Q}}$	Y	Z	A	B	$\overline{\text{EN}}$	$\overline{\text{Q}}$	Y	Z
H	L	L	H	L	H	H	L	?	?	?
L	L	H	L	H	L	H	L	H	L	H
X	H	?	Z	Z	H	L	L	L	H	L
Open	L	?	?	?	L	L	L	?	?	?
X	Open	?	?	?	X	X	H	?	Z	Z
					Open	Open	L	?	?	?
					X	X	Open	?	?	?

(1) H = high, L = low, Z = high impedance, ? = indeterminate

**DRF PACKAGE
TOP VIEW**

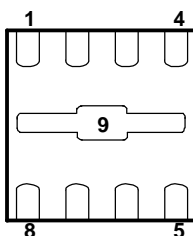
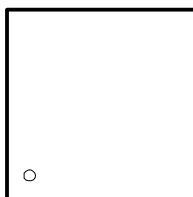

BOTTOM VIEW

Package Pin Assignments – Numerical Listing

SN65LVDS18, SN65LVP18		SN65LVDS19, SN65LVP19	
PIN	SIGNAL	PIN	SIGNAL
1	$\overline{\text{Q}}$	1	$\overline{\text{Q}}$
2	A	2	A
3	V_{BB}	3	B
4	GC	4	V_{BB}
5	$\overline{\text{EN}}$	5	$\overline{\text{EN}}$
6	Z	6	Z
7	Y	7	Y
8	V_{CC}	8	V_{CC}
9	GND	9	GND

TYPICAL CHARACTERISTICS

SUPPLY CURRENT
 VS
 FREQUENCY

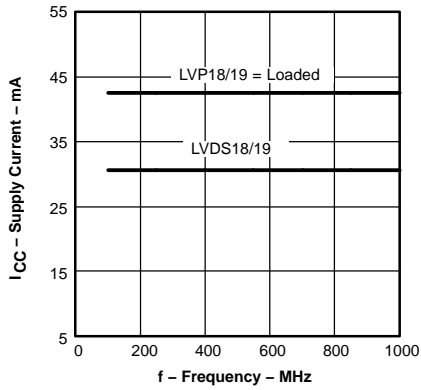

Figure 7.

SUPPLY CURRENT
 VS
 FREE-AIR TEMPERATURE

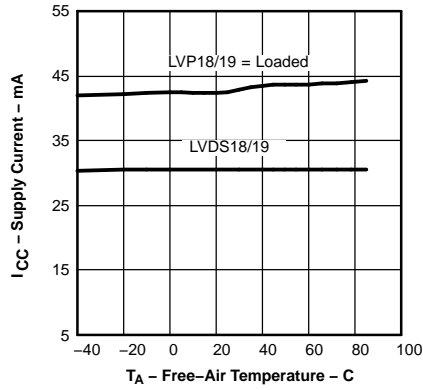

Figure 8.

LVDS18/19 RISE/FALL TIME
 VS
 FREE-AIR TEMPERATURE

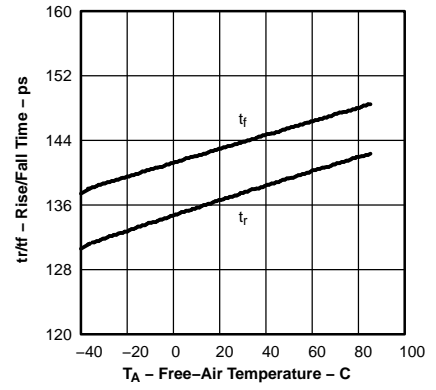

Figure 9.

LVP18/19 RISE/FALL TIME
 VS
 FREE-AIR TEMPERATURE

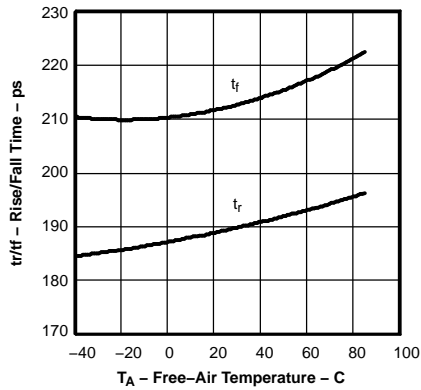

Figure 10.

LVDS18/19 PROPAGATION DELAY
 TIME
 VS
 FREE-AIR TEMPERATURE

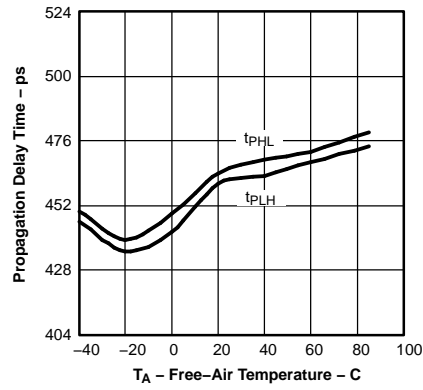

Figure 11.

PERIOD JITTER
 VS
 FREQUENCY

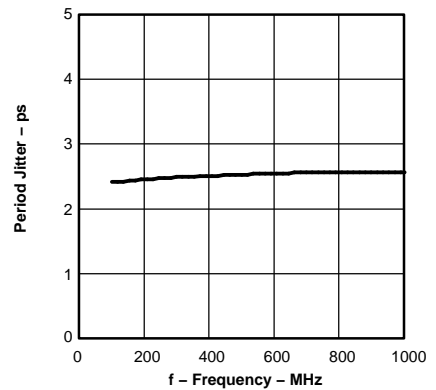

Figure 12.

CYCLE-TO-CYCLE JITTER
 VS
 FREQUENCY

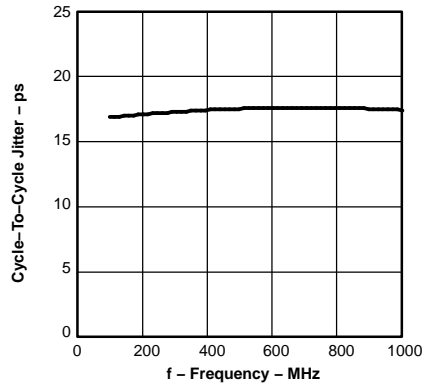
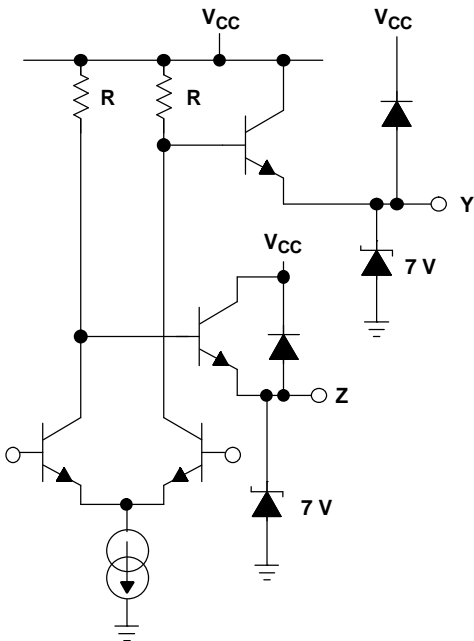

Figure 13.

EQUIVALENT INPUT AND OUTPUT SCHEMATIC DIAGRAMS

OUTPUT LVP18/19



OUTPUT LVDS18/19

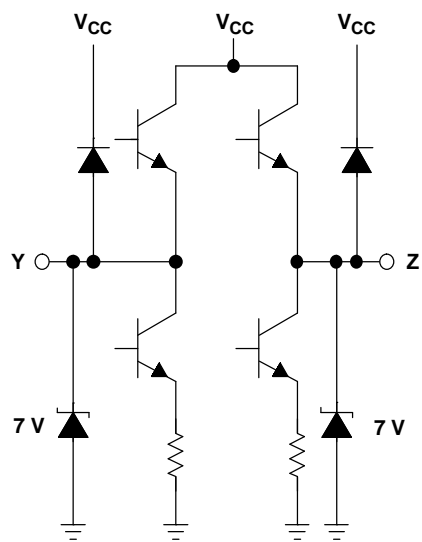

ENABLE

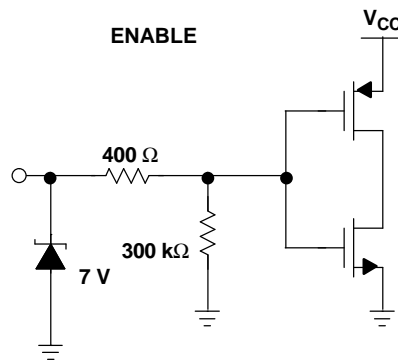

INPUT

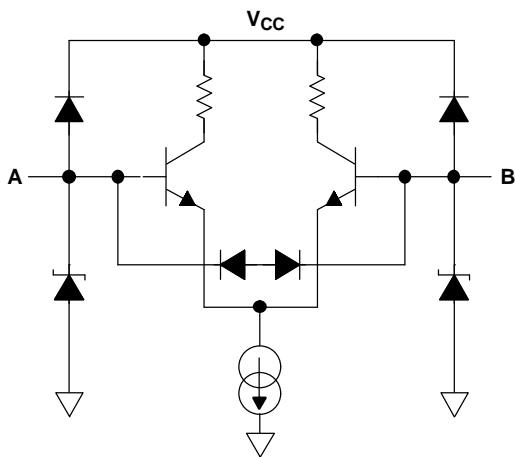

OUTPUT

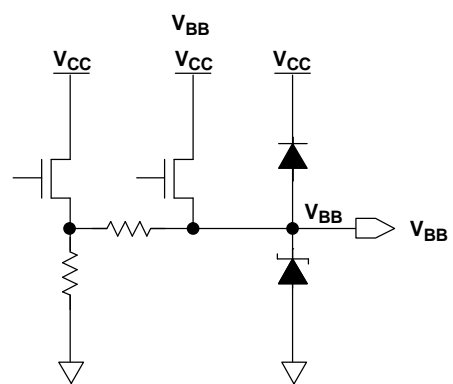

PACKAGING INFORMATION

Orderable Device	Status (1)	Package Type	Package Drawing	Pins	Package Qty	Eco Plan (2)	Lead/Ball Finish (6)	MSL Peak Temp (3)	Op Temp (°C)	Device Marking (4/5)	Samples
SN65LVDS18DRFT	ACTIVE	WSO	DRF	8	250	Green (RoHS & no Sb/Br)	NIPDAU	Level-1-260C-UNLIM	-40 to 85	ER	Samples
SN65LVDS19DRFT	ACTIVE	WSO	DRF	8	250	Green (RoHS & no Sb/Br)	NIPDAU	Level-1-260C-UNLIM	-40 to 85	ET	Samples
SN65LVP18DRFT	ACTIVE	WSO	DRF	8	250	Green (RoHS & no Sb/Br)	NIPDAU	Level-1-260C-UNLIM	-40 to 85	EP	Samples
SN65LVP19DRFT	ACTIVE	WSO	DRF	8	250	Green (RoHS & no Sb/Br)	NIPDAU	Level-1-260C-UNLIM	-40 to 85	ES	Samples

(1) The marketing status values are defined as follows:

ACTIVE: Product device recommended for new designs.

LIFEBUY: TI has announced that the device will be discontinued, and a lifetime-buy period is in effect.

NRND: Not recommended for new designs. Device is in production to support existing customers, but TI does not recommend using this part in a new design.

PREVIEW: Device has been announced but is not in production. Samples may or may not be available.

OBSELETE: TI has discontinued the production of the device.

(2) **RoHS:** TI defines "RoHS" to mean semiconductor products that are compliant with the current EU RoHS requirements for all 10 RoHS substances, including the requirement that RoHS substance do not exceed 0.1% by weight in homogeneous materials. Where designed to be soldered at high temperatures, "RoHS" products are suitable for use in specified lead-free processes. TI may reference these types of products as "Pb-Free".

RoHS Exempt: TI defines "RoHS Exempt" to mean products that contain lead but are compliant with EU RoHS pursuant to a specific EU RoHS exemption.

Green: TI defines "Green" to mean the content of Chlorine (Cl) and Bromine (Br) based flame retardants meet JS709B low halogen requirements of <=1000ppm threshold. Antimony trioxide based flame retardants must also meet the <=1000ppm threshold requirement.

(3) MSL, Peak Temp. - The Moisture Sensitivity Level rating according to the JEDEC industry standard classifications, and peak solder temperature.

(4) There may be additional marking, which relates to the logo, the lot trace code information, or the environmental category on the device.

(5) Multiple Device Markings will be inside parentheses. Only one Device Marking contained in parentheses and separated by a "-" will appear on a device. If a line is indented then it is a continuation of the previous line and the two combined represent the entire Device Marking for that device.

(6) Lead/Ball Finish - Orderable Devices may have multiple material finish options. Finish options are separated by a vertical ruled line. Lead/Ball Finish values may wrap to two lines if the finish value exceeds the maximum column width.

Important Information and Disclaimer:The information provided on this page represents TI's knowledge and belief as of the date that it is provided. TI bases its knowledge and belief on information provided by third parties, and makes no representation or warranty as to the accuracy of such information. Efforts are underway to better integrate information from third parties. TI has taken and

continues to take reasonable steps to provide representative and accurate information but may not have conducted destructive testing or chemical analysis on incoming materials and chemicals. TI and TI suppliers consider certain information to be proprietary, and thus CAS numbers and other limited information may not be available for release.

In no event shall TI's liability arising out of such information exceed the total purchase price of the TI part(s) at issue in this document sold by TI to Customer on an annual basis.

TAPE AND REEL INFORMATION

QUADRANT ASSIGNMENTS FOR PIN 1 ORIENTATION IN TAPE

*All dimensions are nominal

Device	Package Type	Package Drawing	Pins	SPQ	Reel Diameter (mm)	Reel Width W1 (mm)	A0 (mm)	B0 (mm)	K0 (mm)	P1 (mm)	W (mm)	Pin1 Quadrant
SN65LVDS18DRFT	WSON	DRF	8	250	330.0	8.8	2.3	2.3	1.0	4.0	8.0	Q2
SN65LVDS19DRFT	WSON	DRF	8	250	330.0	8.8	2.3	2.3	1.0	4.0	8.0	Q2
SN65LVP18DRFT	WSON	DRF	8	250	330.0	8.8	2.3	2.3	1.0	4.0	8.0	Q2
SN65LVP19DRFT	WSON	DRF	8	250	330.0	8.8	2.3	2.3	1.0	4.0	8.0	Q2

TAPE AND REEL BOX DIMENSIONS



*All dimensions are nominal

Device	Package Type	Package Drawing	Pins	SPQ	Length (mm)	Width (mm)	Height (mm)
SN65LVDS18DRFT	WSON	DRF	8	250	337.0	343.0	29.0
SN65LVDS19DRFT	WSON	DRF	8	250	337.0	343.0	29.0
SN65LVP18DRFT	WSON	DRF	8	250	337.0	343.0	29.0
SN65LVP19DRFT	WSON	DRF	8	250	337.0	343.0	29.0

DRF (S-PWSON-N8)

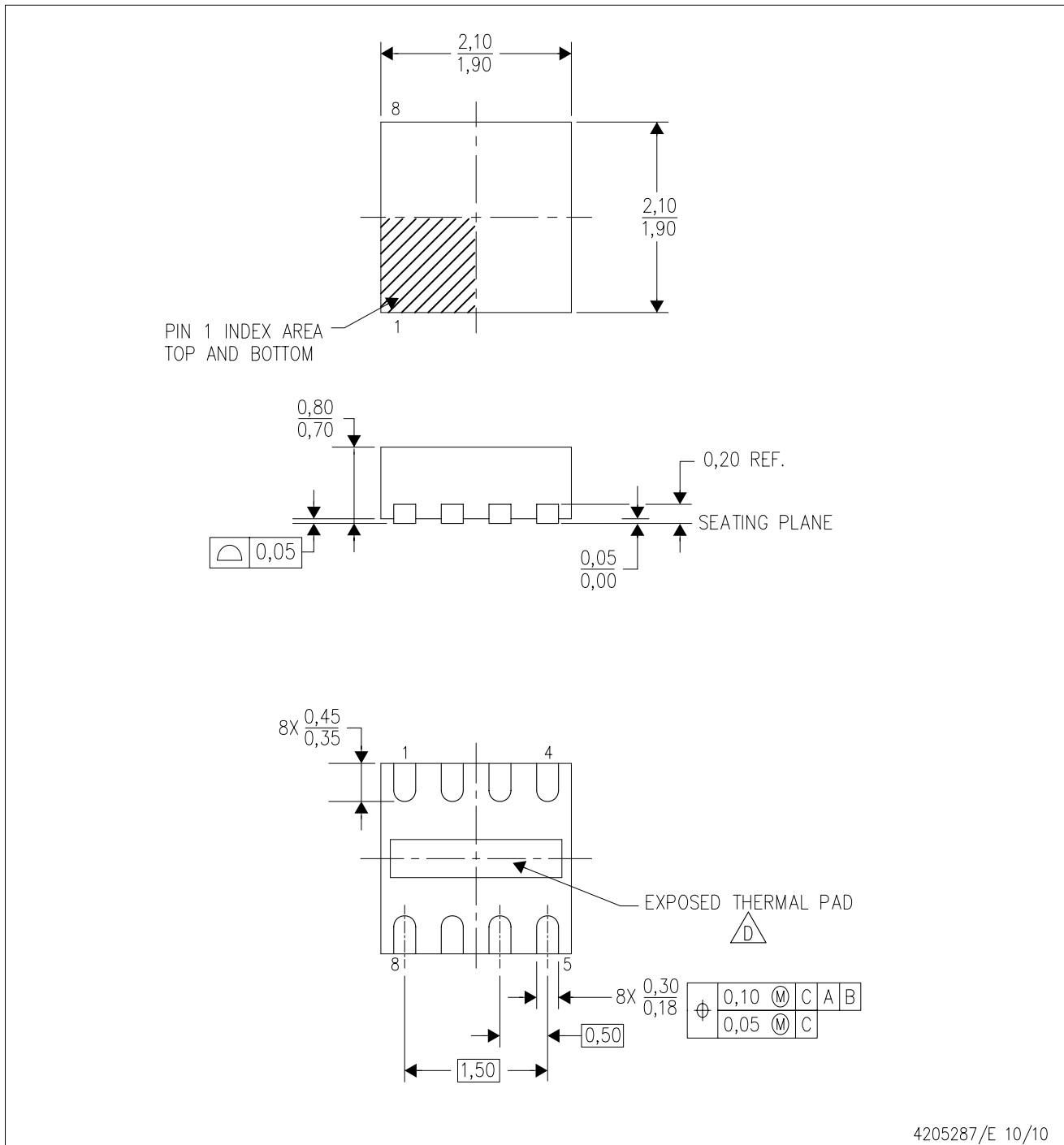
PLASTIC SMALL OUTLINE NO-LEAD



- NOTES:
- A. All linear dimensions are in millimeters. Dimensioning and tolerancing per ASME Y14.5M-1994.
 - B. This drawing is subject to change without notice.
 - C. Quad Flatpack, No-Leads (QFN) package configuration.
 -  D. The Package thermal pad must be soldered to the board for thermal and mechanical performance. See product data sheet for details regarding the exposed thermal pad dimensions.
 - E. Falls within JEDEC MO-229.

THERMAL PAD MECHANICAL DATA

DRF (S-PWSON-N8)

PLASTIC SMALL OUTLINE NO-LEAD

THERMAL INFORMATION

This package incorporates an exposed thermal pad that is designed to be attached directly to an external heatsink. The thermal pad must be soldered directly to the printed circuit board (PCB). After soldering, the PCB can be used as a heatsink. In addition, through the use of thermal vias, the thermal pad can be attached directly to the appropriate copper plane shown in the electrical schematic for the device, or alternatively, can be attached to a special heatsink structure designed into the PCB. This design optimizes the heat transfer from the integrated circuit (IC).

For information on the Quad Flatpack No-Lead (QFN) package and its advantages, refer to Application Report, QFN/SOIC PCB Attachment, Texas Instruments Literature No. SLUA271. This document is available at www.ti.com.

The exposed thermal pad dimensions for this package are shown in the following illustration.

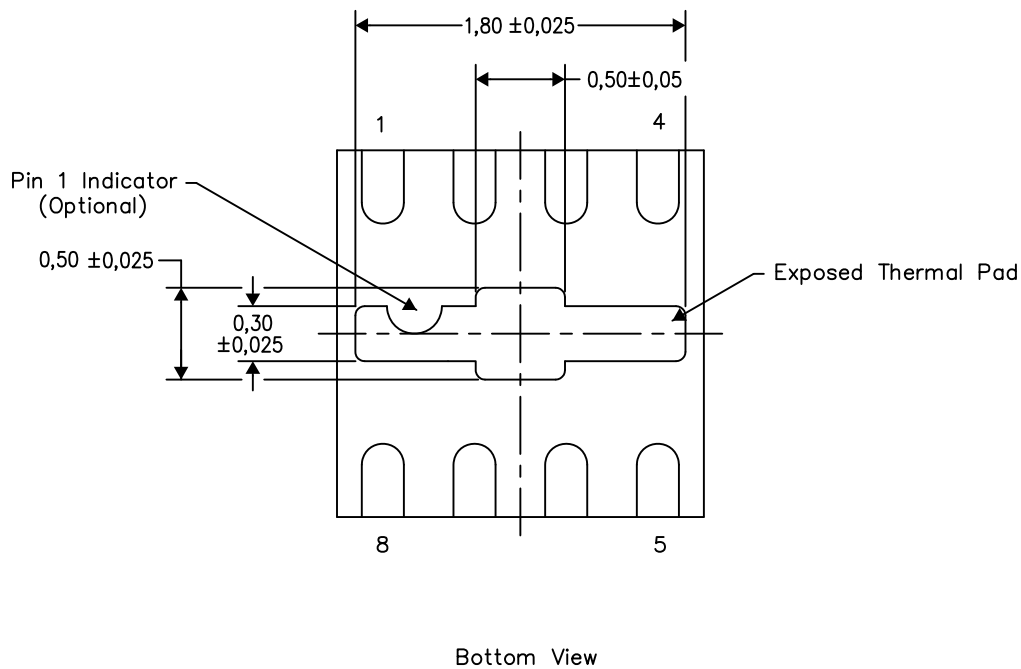

Exposed Thermal Pad Dimensions

4206840/H 12/14

NOTE: A. All linear dimensions are in millimeters

DRF (S-PWSON-N8)

PLASTIC SMALL OUTLINE NO-LEAD

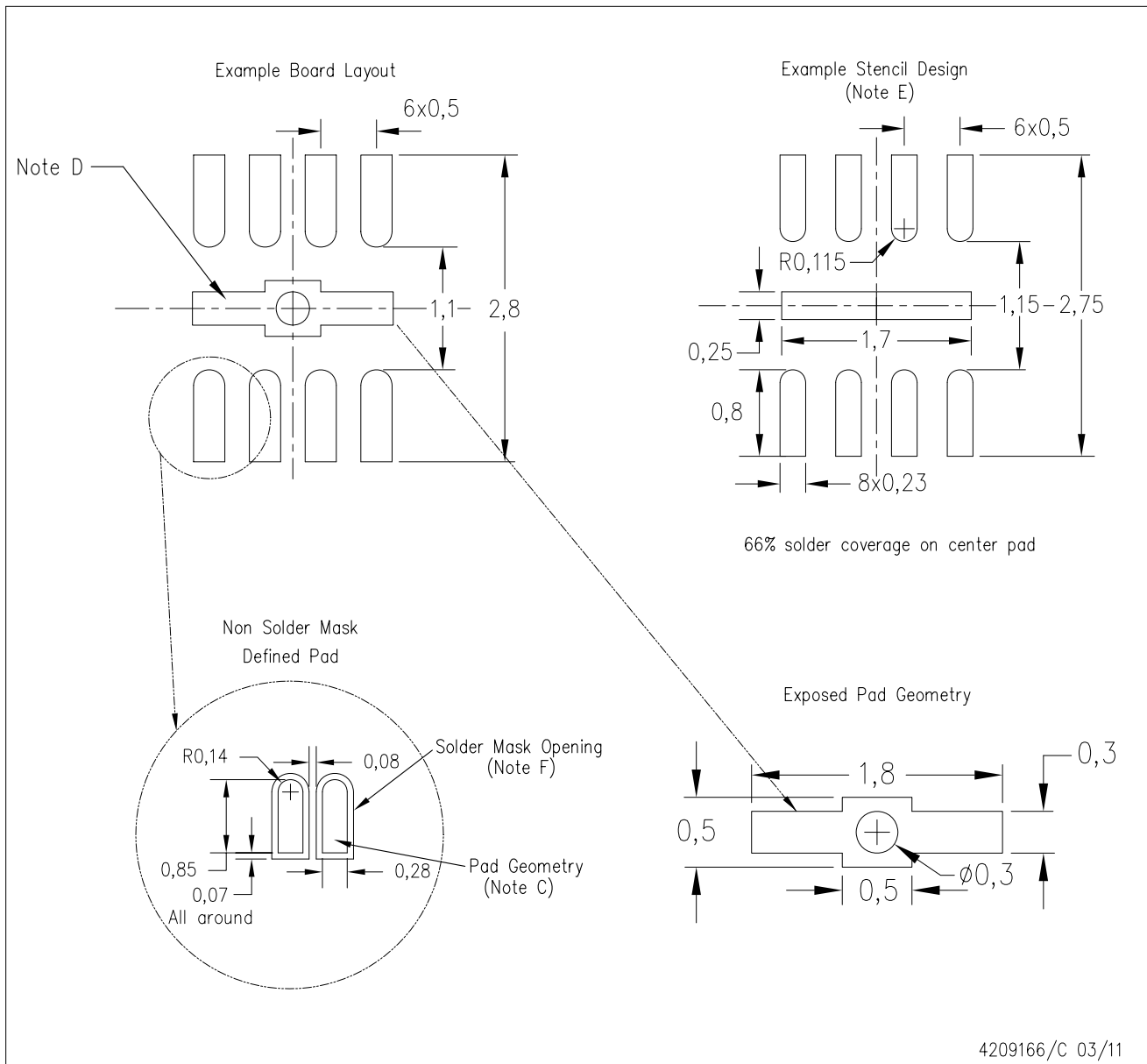

- NOTES:
- All linear dimensions are in millimeters.
 - This drawing is subject to change without notice.
 - Publication IPC-7351 is recommended for alternate designs.
 - This package is designed to be soldered to a thermal pad on the board. Refer to Application Note, Quad Flat-Pack Packages, Texas Instruments Literature No. SLUA271, and also the Product Data Sheets for specific thermal information, via requirements, and recommended board layout. These documents are available at www.ti.com <<http://www.ti.com>>.
 - Laser cutting apertures with trapezoidal walls and also rounding corners will offer better paste release. Customers should contact their board assembly site for stencil design recommendations. Refer to IPC 7525 for stencil design considerations.
 - Customers should contact their board fabrication site for minimum solder mask web tolerances between signal pads.

IMPORTANT NOTICE AND DISCLAIMER

TI PROVIDES TECHNICAL AND RELIABILITY DATA (INCLUDING DATASHEETS), DESIGN RESOURCES (INCLUDING REFERENCE DESIGNS), APPLICATION OR OTHER DESIGN ADVICE, WEB TOOLS, SAFETY INFORMATION, AND OTHER RESOURCES "AS IS" AND WITH ALL FAULTS, AND DISCLAIMS ALL WARRANTIES, EXPRESS AND IMPLIED, INCLUDING WITHOUT LIMITATION ANY IMPLIED WARRANTIES OF MERCHANTABILITY, FITNESS FOR A PARTICULAR PURPOSE OR NON-INFRINGEMENT OF THIRD PARTY INTELLECTUAL PROPERTY RIGHTS.

These resources are intended for skilled developers designing with TI products. You are solely responsible for (1) selecting the appropriate TI products for your application, (2) designing, validating and testing your application, and (3) ensuring your application meets applicable standards, and any other safety, security, or other requirements. These resources are subject to change without notice. TI grants you permission to use these resources only for development of an application that uses the TI products described in the resource. Other reproduction and display of these resources is prohibited. No license is granted to any other TI intellectual property right or to any third party intellectual property right. TI disclaims responsibility for, and you will fully indemnify TI and its representatives against, any claims, damages, costs, losses, and liabilities arising out of your use of these resources.

TI's products are provided subject to TI's Terms of Sale (www.ti.com/legal/termsofsale.html) or other applicable terms available either on ti.com or provided in conjunction with such TI products. TI's provision of these resources does not expand or otherwise alter TI's applicable warranties or warranty disclaimers for TI products.

Mailing Address: Texas Instruments, Post Office Box 655303, Dallas, Texas 75265
Copyright © 2020, Texas Instruments Incorporated