

PULSE-WIDTH-MODULATION CONTROL CIRCUITS

FEATURES

- Qualified for Automotive Applications
- Complete PWM Power Control
- 3.6-V to 40-V Operation
- Internal Undervoltage-Lockout Circuit
- Internal Short-Circuit Protection
- Oscillator Frequency: 20 kHz to 500 kHz
- Variable Dead Time Provides Control Over Total Range
- $\pm 3\%$ Tolerance on Reference Voltage
- Available in Q-Temperature Automotive
 - High-Reliability Automotive Applications
 - Configuration Control / Print Support
 - Qualification to Automotive Standards

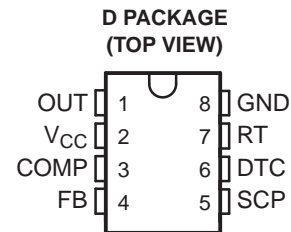

DESCRIPTION

The TL5001A incorporates on a single monolithic chip all the functions required for a pulse-width-modulation (PWM) control circuit. Designed primarily for power-supply control, the TL5001A contains an error amplifier, a regulator, an oscillator, a PWM comparator with a dead-time-control input, undervoltage lockout (UVLO), short-circuit protection (SCP), and an open-collector output transistor. The TL5001A has a typical reference voltage tolerance of $\pm 3\%$.

The error-amplifier common-mode voltage ranges from 0 V to 1.5 V. The noninverting input of the error amplifier is connected to a 1-V reference. Dead-time control (DTC) can be set to provide 0% to 100% dead time by connecting an external resistor between DTC and GND. The oscillator frequency is set by terminating RT with an external resistor to GND. During low V_{CC} conditions, the UVLO circuit turns the output off until V_{CC} recovers to its normal operating range.

The TL5001A is characterized for operation from -40°C to 125°C .

AVAILABLE OPTIONS⁽¹⁾

T _A	PACKAGED DEVICES ⁽²⁾
	SMALL OUTLINE (D) ⁽³⁾
–40°C to 125°C	TL5001AQDRQ1

- (1) For the most current package and ordering information, see the Package Option Addendum at the end of this document, or see the TI web site at www.ti.com.
- (2) Package drawings, thermal data, and symbolization are available at www.ti.com/packaging.
- (3) The D package is available taped and reeled. Add the suffix R to the device type (e.g., TL5001ADR).



Please be aware that an important notice concerning availability, standard warranty, and use in critical applications of Texas Instruments semiconductor products and disclaimers thereto appears at the end of this data sheet.

SCHEMATIC FOR TYPICAL APPLICATION

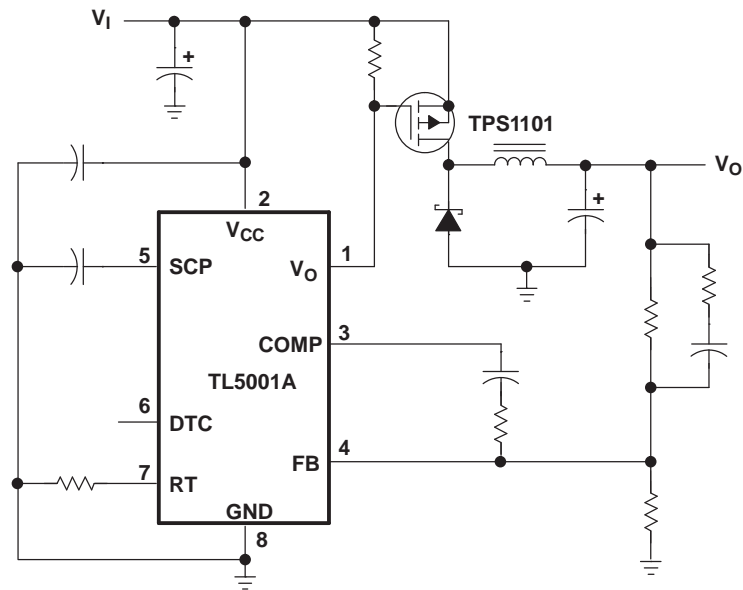

FUNCTIONAL BLOCK DIAGRAM

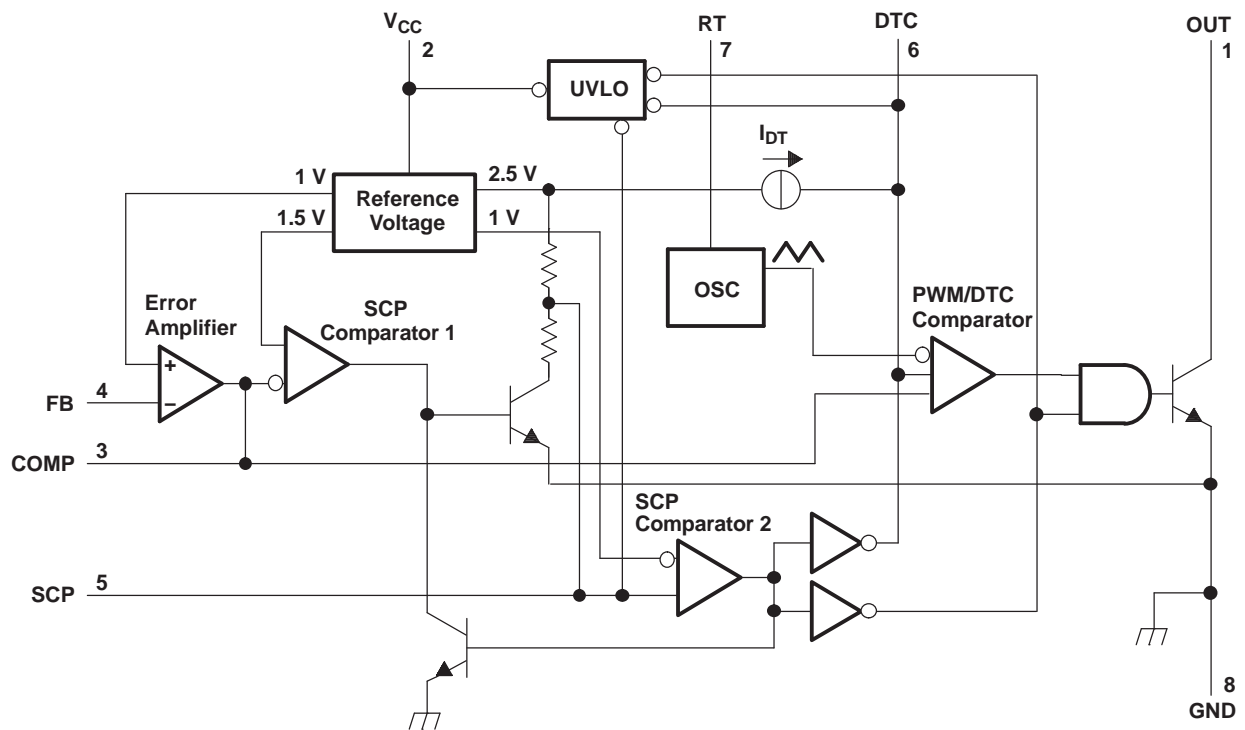

DETAILED DESCRIPTION

VOLTAGE REFERENCE

A 2.5-V regulator operating from V_{CC} is used to power the internal circuitry of the TL5001A and as a reference for the error amplifier and SCP circuits. A resistive divider provides a 1-V reference for the error amplifier noninverting input which typically is within 2% of nominal over the operating temperature range.

ERROR AMPLIFIER

The error amplifier compares a sample of the dc-to-dc converter output voltage to the 1-V reference and generates an error signal for the PWM comparator. The dc-to-dc converter output voltage is set by selecting the error-amplifier gain (see Figure 1), using the following expression:

$$V_O = (1 + R1/R2) (1 \text{ V})$$

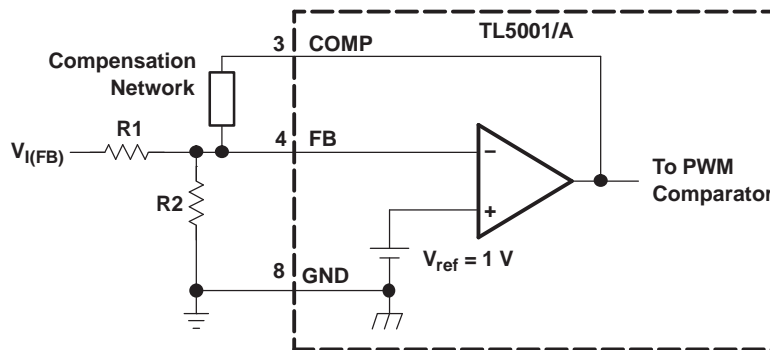

Figure 1. Error-Amplifier Gain Setting

The error-amplifier output is brought out as COMP for use in compensating the dc-to-dc converter control loop for stability. Because the amplifier can only source 45 μ A, the total dc-load resistance should be 100 k Ω or more.

OSCILLATOR/PWM

The oscillator frequency (f_{osc}) can be set between 20 kHz and 500 kHz by connecting a resistor between RT and GND. Acceptable resistor values range from 15 k Ω to 250 k Ω . The oscillator frequency can be determined by using the graph shown in Figure 5.

The oscillator output is a triangular wave with a minimum value of approximately 0.7 V and a maximum value of approximately 1.3 V. The PWM comparator compares the error-amplifier output voltage and the DTC input voltage to the triangular wave and turns the output transistor off whenever the triangular wave is greater than the lesser of the two inputs.

DEAD-TIME CONTROL (DTC)

DTC provides a means of limiting the output-switch duty cycle to a value less than 100%, which is critical for boost and flyback converters. A current source generates a reference current (I_{DT}) at DTC that is nominally equal to the current at the oscillator timing terminal (RT). Connecting a resistor between DTC and GND generates a dead-time reference voltage (V_{DT}), which the PWM/DTC comparator compares to the oscillator triangle wave as described in the previous section. Nominally, the maximum duty cycle is 0% when V_{DT} is 0.7 V or less and 100% when V_{DT} is 1.3 V or greater. Because the triangle wave amplitude is a function of frequency and the source impedance of RT is relatively high (1250 Ω), choosing R_{DT} for a specific maximum duty cycle (D) is accomplished using the following equation and the voltage limits for the frequency in question as found in Figure 11 ($V_{osc,max}$ and $V_{osc,min}$ are the maximum and minimum oscillator levels):

$$R_{DT} = \frac{(R_t + 1250) [D(V_{osc,max} - V_{osc,min}) + V_{osc,min}]}{V_{RT}} ; V_{RT} = 1 \text{ V} \quad (1)$$

Where

R_{DT} and R_t are in Ω , D is in decimal

Soft start can be implemented by paralleling the DTC resistor with a capacitor (C_{DT}) as shown in Figure 2. During soft start, the voltage at DTC is derived by the following equation:

$$V_{DT} \approx I_{DT}R_{DT}\left(1 - e^{-\frac{t}{R_{DT}C_{DT}}}\right) \tag{2}$$

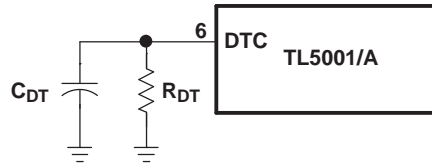

Figure 2. Soft-Start Circuit

If the dc-to-dc converter must be in regulation within a specified period of time, the time constant ($R_{DT}C_{DT}$) should be $t_0/3$ to $t_0/5$. The TL5001A remains off until $V_{DT} \approx 0.7$ V, the minimum ramp value. C_{DT} is discharged every time UVLO or SCP becomes active.

UNDERVOLTAGE-LOCKOUT (UVLO) PROTECTION

The undervoltage-lockout circuit turns the output transistor off and resets the SCP latch whenever the supply voltage drops too low (approximately 3 V at 25°C) for proper operation. A hysteresis voltage of 200 mV eliminates false triggering on noise and chattering.

SHORT-CIRCUIT PROTECTION (SCP)

The TL5001A includes short-circuit protection (see Figure 3), which turns the power switch off to prevent damage when the converter output is shorted. When activated, the SCP prevents the switch from being turned on until the internal latching circuit is reset. The circuit is reset by reducing the input voltage until UVLO becomes active or until the SCP terminal is pulled to ground externally.

When a short circuit occurs, the error-amplifier output at COMP rises to increase the power-switch duty cycle in an attempt to maintain the output voltage. SCP comparator 1 starts an RC timing circuit when COMP exceeds 1.5 V. If the short is removed and the error-amplifier output drops below 1.5 V before time out, normal converter operation continues. If the fault is still present at the end of the time-out period, the timer sets the latching circuit and turns off the TL5001/A output transistor.

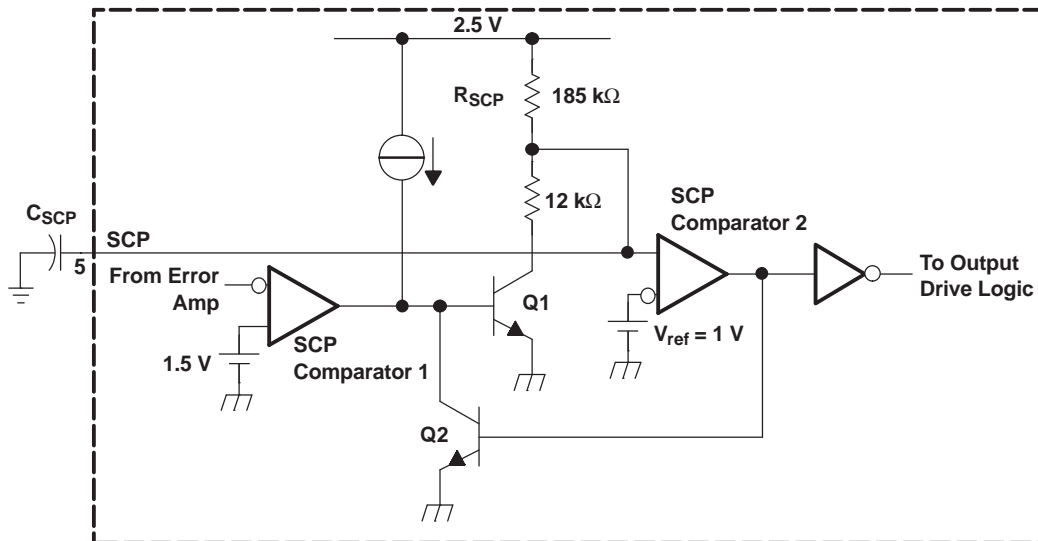

Figure 3. SCP Circuit

The timer operates by charging an external capacitor (C_{SCP}) connected between the SCP terminal and ground, towards 2.5 V through a 185-k Ω resistor (R_{SCP}). The circuit begins charging from an initial voltage of approximately 185 mV and times out when the capacitor voltage reaches 1 V. The output of SCP comparator 2 then goes high, turns on Q2, and latches the timer circuit. The expression for setting the SCP time period is derived from [Equation 3](#):

$$V_{SCP} = (2.5 - 0.185) (1 - e^{-t/\tau}) + 0.185 \quad (3)$$

Where

$$\tau = R_{SCP}C_{SCP}$$

The end of the time-out period (t_{SCP}) occurs when $V_{SCP} = 1$ V. Solving for C_{SCP} yields [Equation 4](#):

$$C_{SCP} = 12.46 \times t_{SCP} \quad (4)$$

Where

t is in seconds, C is in μ F

t_{SCP} must be much longer (generally 10 to 15 times) than the converter start-up period, or the converter will not start.

OUTPUT TRANSISTOR

The output of the TL5001A is an open-collector transistor with a maximum collector current rating of 21 mA and a voltage rating of 51 V. The output is turned on under the following conditions: the oscillator triangle wave is lower than both the DTC voltage and the error-amplifier output voltage, the UVLO circuit is inactive, and the short-circuit protection circuit is inactive.

ABSOLUTE MAXIMUM RATINGS

over operating free-air temperature range (unless otherwise noted) ⁽¹⁾

V _{CC}	Supply voltage ⁽²⁾	41 V
V _{I(FB)}	Amplifier input voltage	20 V
V _O	Output voltage, OUT	51 V
I _O	Output current, OUT	21 mA
I _{O(peak)}	Output peak current, OUT	100 mA
	Continuous total power dissipation	See <i>Dissipation Rating</i>
T _A	Operating ambient temperature range, TL5001AQDRQ1	–40°C to 125°C
T _{stg}	Storage temperature range	–65°C to 150°C
	Lead temperature 1,6 mm (1/16 inch) from case for 10 seconds	260°C

- (1) Stresses beyond those listed under "absolute maximum ratings" may cause permanent damage to the device. These are stress ratings only, and functional operation of the device at these or any other conditions beyond those indicated under "recommended operating conditions" is not implied. Exposure to absolute-maximum-rated conditions for extended periods may affect device reliability.
- (2) All voltage values are with respect to network ground terminal.

DISSIPATION RATINGS

PACKAGE	T _A ≤ 25°C POWER RATING	DERATING FACTOR ABOVE T _A = 25°C	T _A = 70°C POWER RATING	T _A = 85°C POWER RATING	T _A = 125°C POWER RATING
D	725 mW	5.8 mW/°C	464 mW	377 mW	145 mW

RECOMMENDED OPERATING CONDITIONS

		MIN	MAX	UNIT
V _{CC}	Supply voltage	3.6	40	V
V _{I(FB)}	Amplifier input voltage	0	1.5	V
V _O	Output voltage, OUT		50	V
I _O	Output current, OUT		20	mA
	COMP source current		45	μA
	COMP dc load resistance	100		kΩ
R _t	Oscillator timing resistor	15	250	kΩ
f _{OSC}	Oscillator frequency	20	500	kHz
T _A	Operating ambient temperature			
		TL5001AQDRQ1		
		–40	125	°C

ELECTRICAL CHARACTERISTICS

 over recommended operating free-air temperature range, $V_{CC} = 6\text{ V}$, $f_{osc} = 100\text{ kHz}$ (unless otherwise noted)

PARAMETER	TEST CONDITIONS		TL5001AQ			UNIT
			MIN	TYP ⁽¹⁾	MAX	
REFERENCE						
Output voltage	$T_A = 25^\circ\text{C}$	COMP connected to FB	0.97	1	1.03	V
	$T_A = \text{MIN to MAX}$		0.94	0.98	1.06	
Input regulation	$T_A = \text{MIN to MAX}$,	$V_{CC} = 3.6\text{ V to }40\text{ V}$		2	12.5	mV
Output voltage change with temperature	$T_A = \text{MIN to MAX}$		-6% ⁽²⁾	2%	6% ⁽²⁾	
UNDERVOLTAGE LOCKOUT						
Upper threshold voltage	$T_A = \text{MIN}, 25^\circ\text{C}$			3		V
	$T_A = \text{MAX}$			2.55		
Lower threshold voltage	$T_A = \text{MIN}, 25^\circ\text{C}$			2.8		V
	$T_A = \text{MAX}$			2.0		
Hysteresis	$T_A = \text{MIN to MAX}$		80	200		mV
Reset threshold voltage	$T_A = \text{MIN}, 25^\circ\text{C}$		2.1	2.55		V
	$T_A = \text{MAX}$		0.35	0.63		
SHORT-CIRCUIT PROTECTION						
SCP threshold voltage	$T_A = \text{MIN}, 25^\circ\text{C}$		0.97	1	1.03	V
	$T_A = \text{MAX}$		0.94	0.98	1.06	
SCP voltage, latched	$T_A = \text{MIN to MAX}$	No pullup	140	185	230	mV
SCP voltage, UVLO standby	$T_A = \text{MIN to MAX}$	No pullup		60	120	mV
Equivalent timing resistance	$T_A = \text{MIN to MAX}$			185		k Ω
SCP comparator 1 threshold voltage	$T_A = \text{MIN to MAX}$			1.5		V
OSCILLATOR						
Frequency	$T_A = \text{MIN to MAX}$	$R_t = 100\text{ k}\Omega$		100		kHz
Standard deviation of frequency	$T_A = \text{MIN to MAX}$			2		kHz
Frequency change with voltage	$T_A = \text{MIN to MAX}$	$V_{CC} = 3.6\text{ V to }40\text{ V}$		1		kHz
Frequency change with temperature	$T_A = \text{MIN to MAX}$	Q suffix	-9 ⁽²⁾	5	9 ⁽²⁾	kHz
		M suffix	-9 ⁽²⁾	5	9 ⁽²⁾	
Voltage at RT	$T_A = \text{MIN to MAX}$			1		V
DEAD-TIME CONTROL						
Output (source) current	$T_A = \text{MIN to MAX}$	$V_{(DT)} = 1.5\text{ V}$	$0.9 \times I_{RT}^{(3)}$		$1.1 \times I_{RT}^{(3)}$	μA
Input threshold voltage	$T_A = 25^\circ\text{C}$	Duty cycle 0%	0.5	0.7		V
		Duty cycle 100%		1.3	1.5	
	$T_A = \text{MIN to MAX}$	Duty cycle 0%	0.4	0.7		
		Duty cycle 100%		1.3	1.7	

 (1) All typical values are at $T_A = 25^\circ\text{C}$.

(2) Not production tested.

(3) Output source current at RT

ELECTRICAL CHARACTERISTICS

over recommended operating free-air temperature range, $V_{CC} = 6\text{ V}$, $f_{osc} = 100\text{ kHz}$ (unless otherwise noted)

PARAMETER		TEST CONDITIONS		TL5001AQ			UNIT	
				MIN	TYP ⁽¹⁾	MAX		
ERROR AMPLIFIER								
Input bias current		$T_A = \text{MIN to MAX}$		-160	-500		nA	
Output voltage swing	Positive	$T_A = \text{MIN to MAX}$		1.5	2.3		V	
	Negative				0.3	0.4	V	
Open-loop voltage amplification		$T_A = \text{MIN to MAX}$		80			dB	
Unity gain bandwidth		$T_A = \text{MIN to MAX}$		1.5			MHz	
Output (sink) current		$T_A = \text{MIN to MAX}$		$V_{I(\text{FB})} = 1.2\text{ V}$, $\text{COMP} = 1\text{ V}$			μA	
Output (source) current	$T_A = \text{MIN}, 25^\circ\text{C}$		$V_{I(\text{FB})} = 0\text{ V}$, $\text{COMP} = 1\text{ V}$		-45	-70	μA	
	$T_A = \text{MAX}$				-30	-45		
OUTPUT								
Output saturation voltage		$T_A = \text{MIN to MAX}$		$I_O = 10\text{ mA}$		1.5	2	V
Off-state current		$T_A = \text{MIN to MAX}$		$V_O = 50\text{ V}$, $V_{CC} = 0$		10		μA
				$V_O = 50\text{ V}$		10		
Short-circuit output current		$T_A = \text{MIN to MAX}$		$V_O = 6\text{ V}$		40		mA
TOTAL DEVICE								
Standby supply current	Off state	$T_A = \text{MIN to MAX}$				1	1.5	mA
Average supply current		$T_A = \text{MIN to MAX}$		$R_L = 100\text{ k}\Omega$		1.4	2.1	mA

(1) All typical values are at $T_A = 25^\circ\text{C}$.

PARAMETER MEASUREMENT INFORMATION

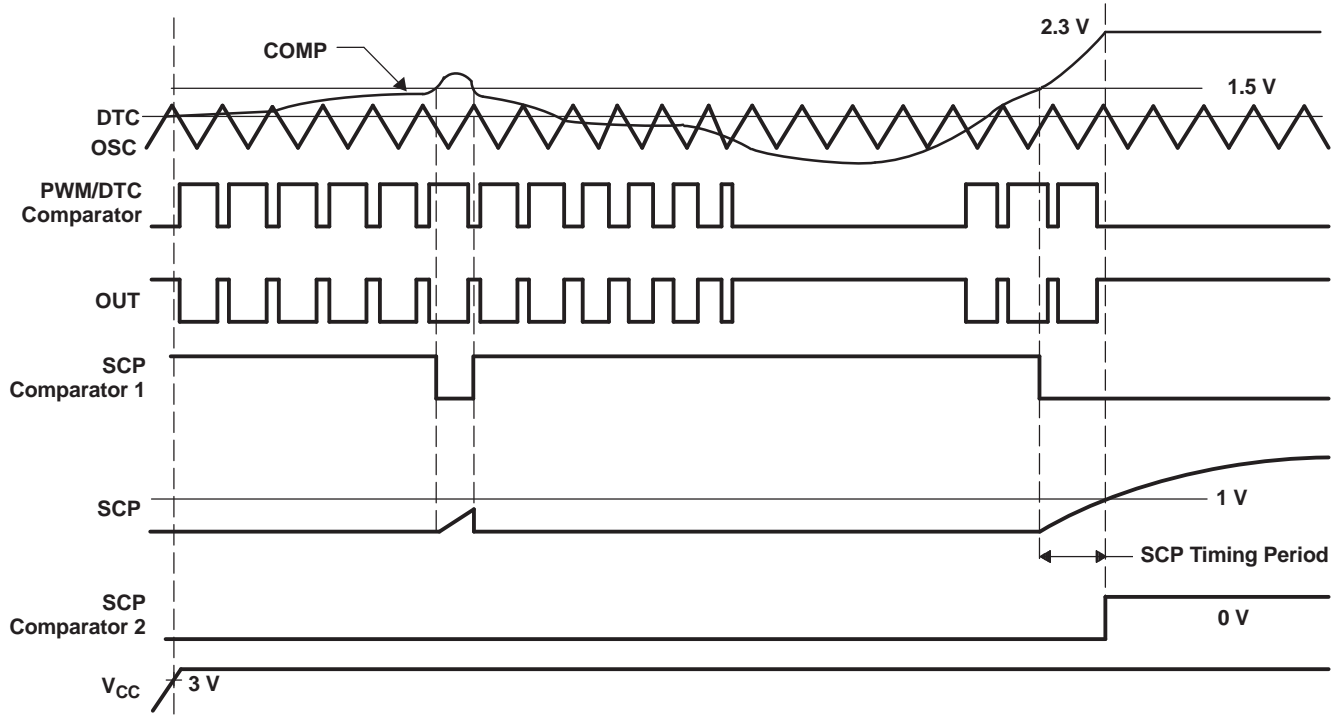

A. The waveforms show timing characteristics for an intermittent short circuit and a longer short circuit that is sufficient to activate SCP.

Figure 4. PWM Timing Diagram

TYPICAL CHARACTERISTICS

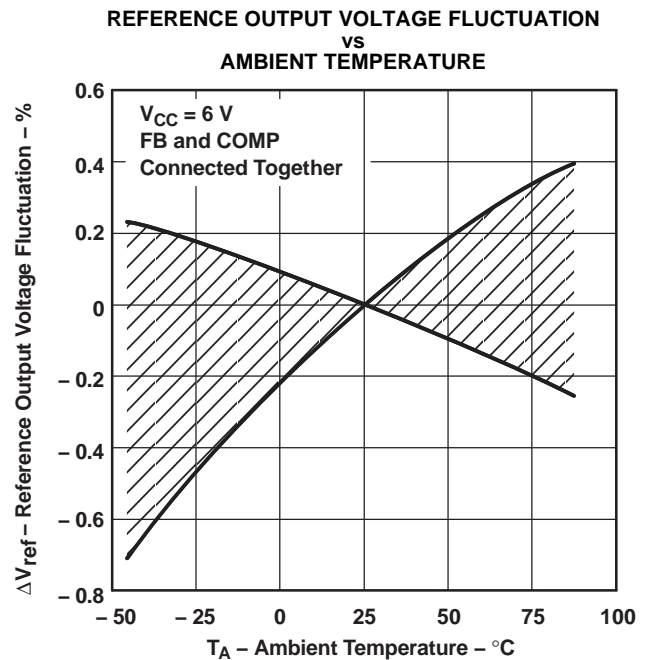
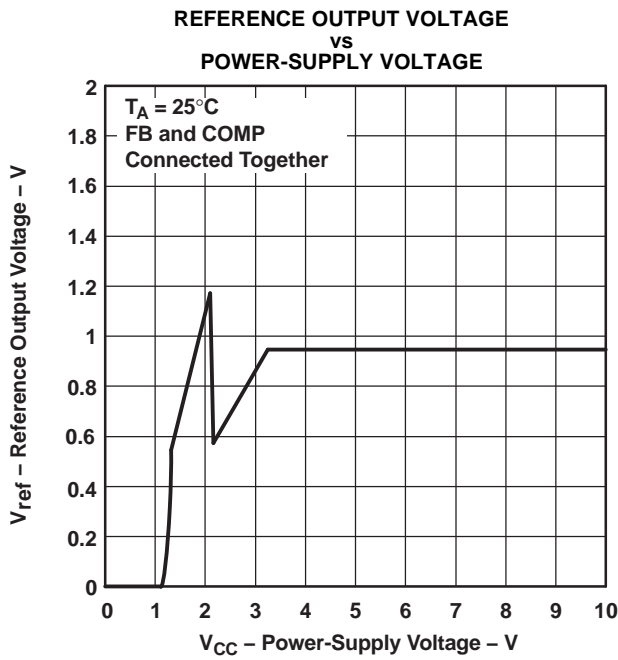
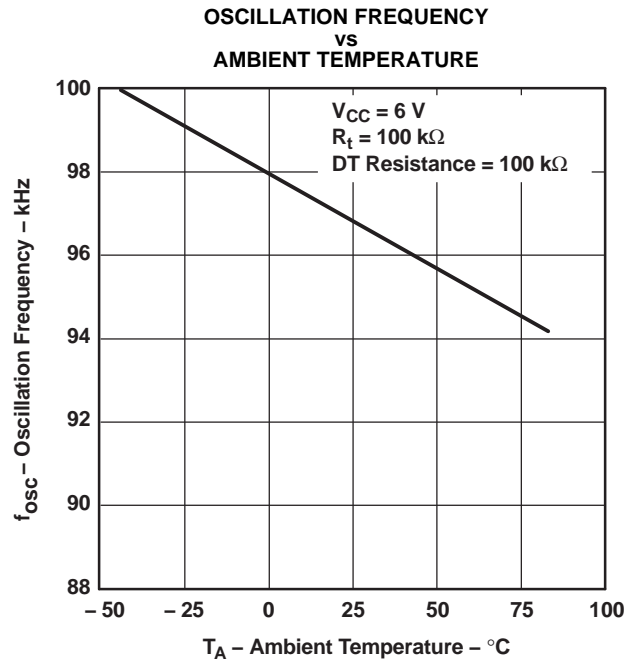
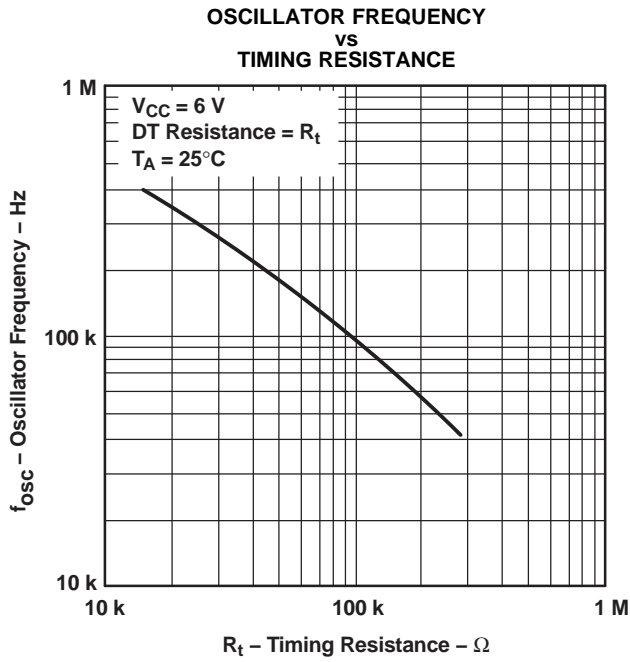

TYPICAL CHARACTERISTICS (continued)

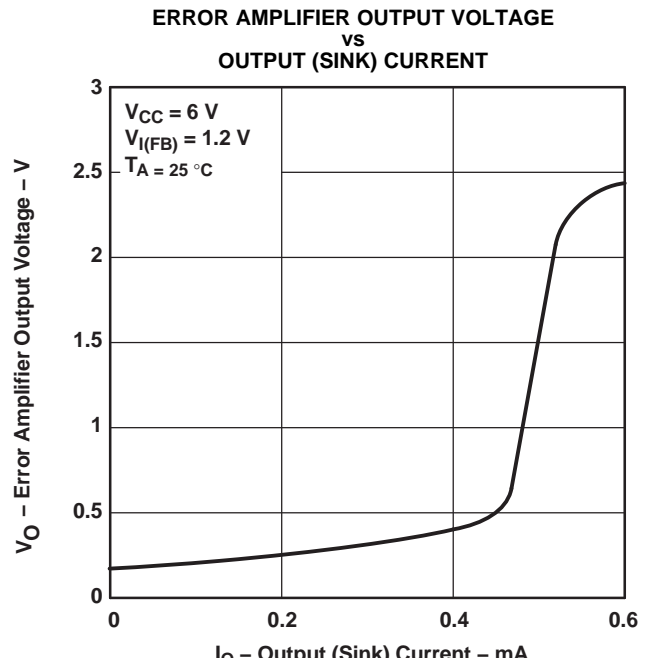
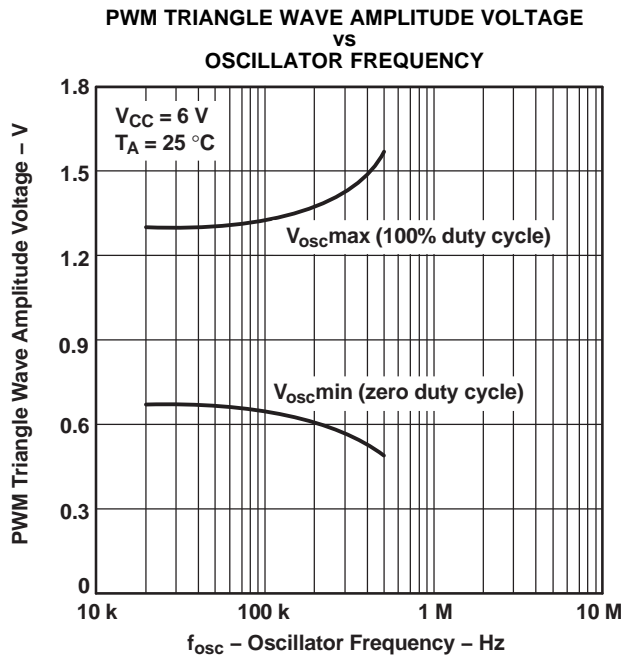
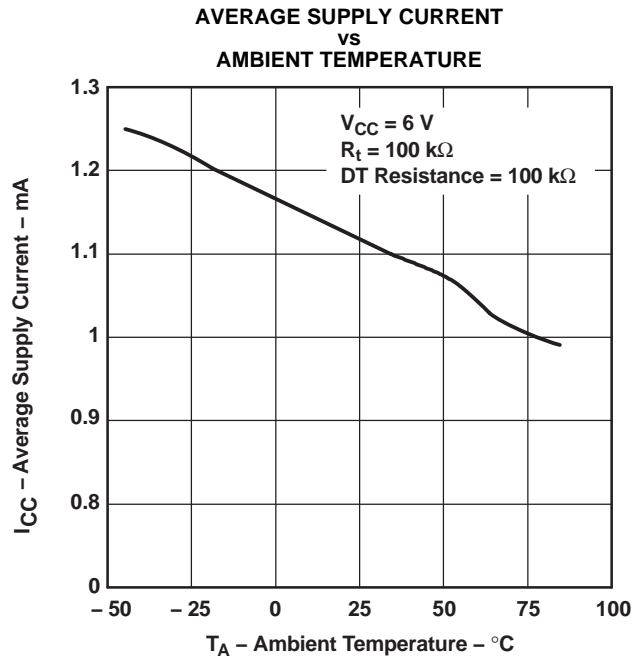
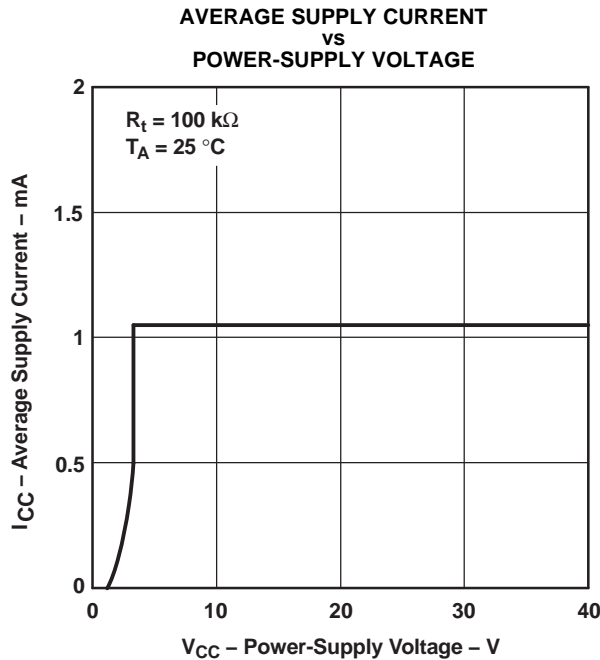

TYPICAL CHARACTERISTICS (continued)

ERROR AMPLIFIER OUTPUT VOLTAGE
vs
OUTPUT (SOURCE) CURRENT

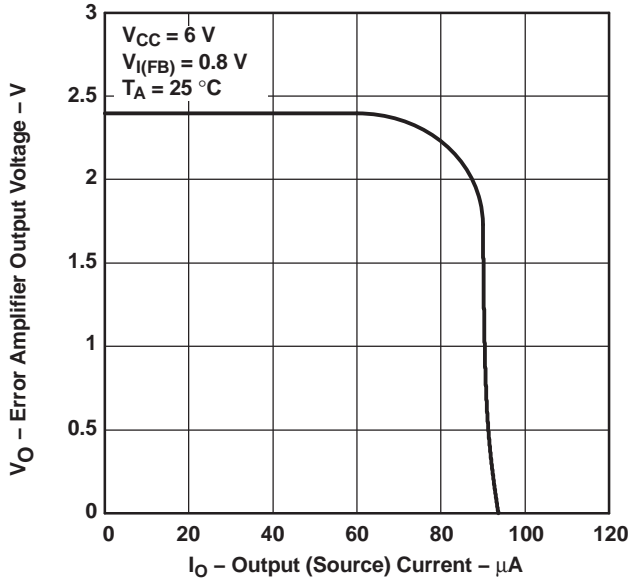

Figure 13.

ERROR AMPLIFIER OUTPUT VOLTAGE
vs
AMBIENT TEMPERATURE

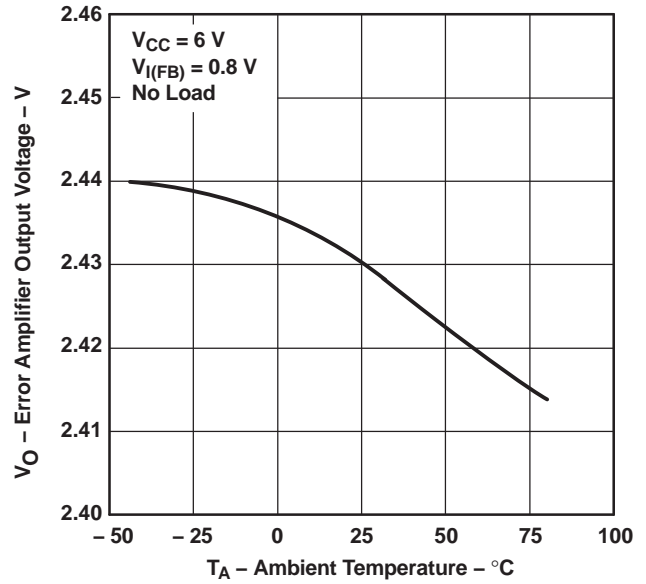

Figure 14.

ERROR AMPLIFIER OUTPUT VOLTAGE
vs
AMBIENT TEMPERATURE

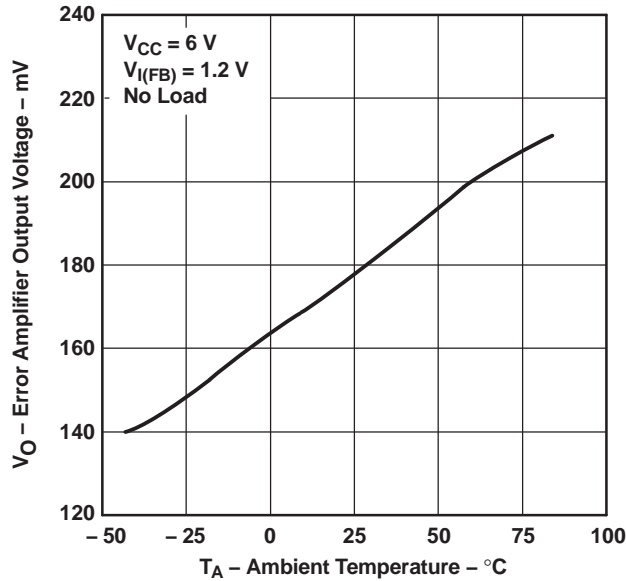

Figure 15.

ERROR AMPLIFIER OPEN-LOOP GAIN
AND PHASE SHIFT
vs
FREQUENCY

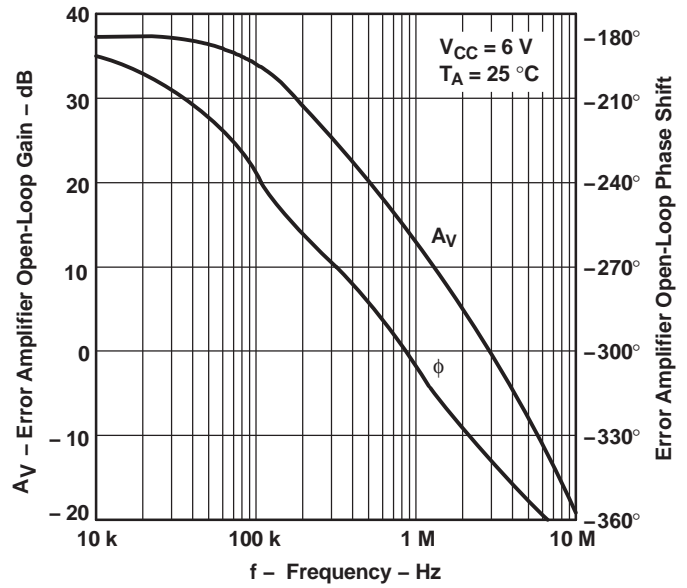

Figure 16.

TYPICAL CHARACTERISTICS (continued)

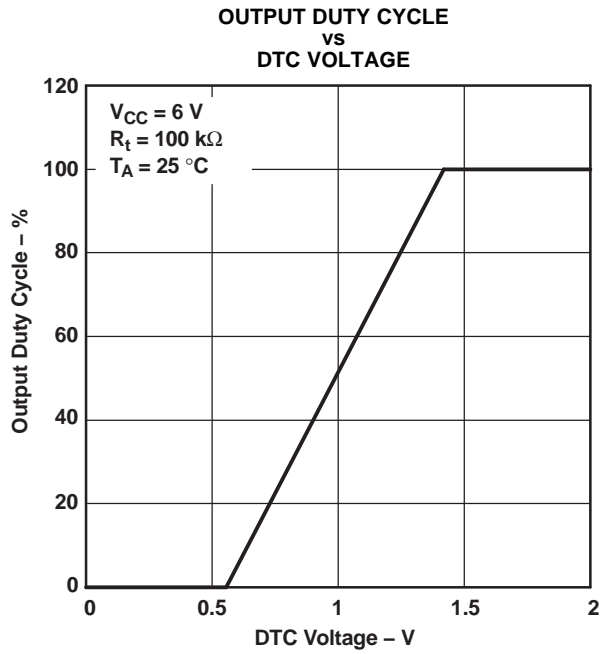

Figure 17.

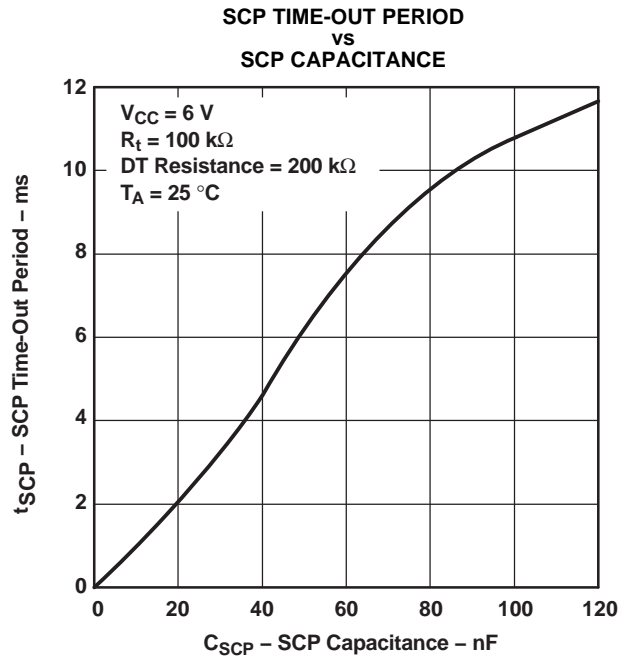

Figure 18.

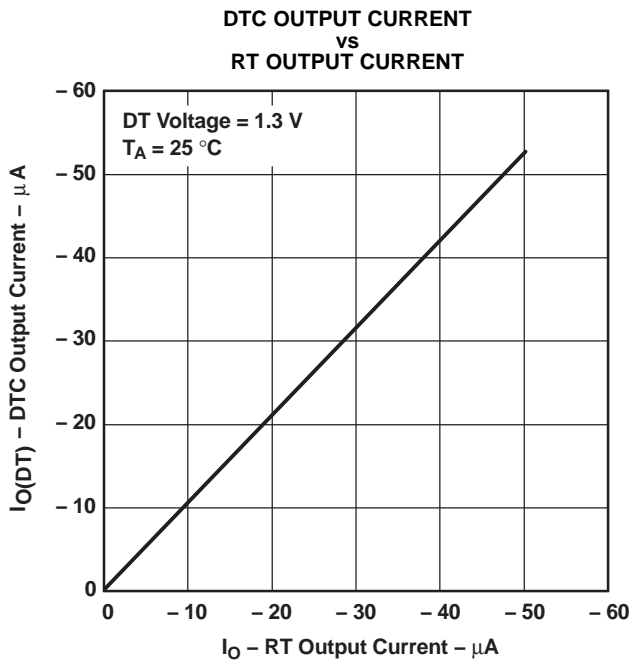

Figure 19.

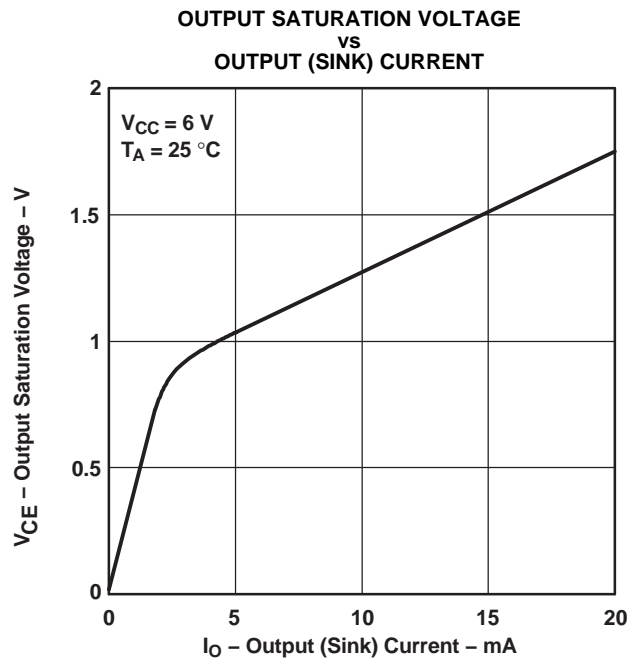
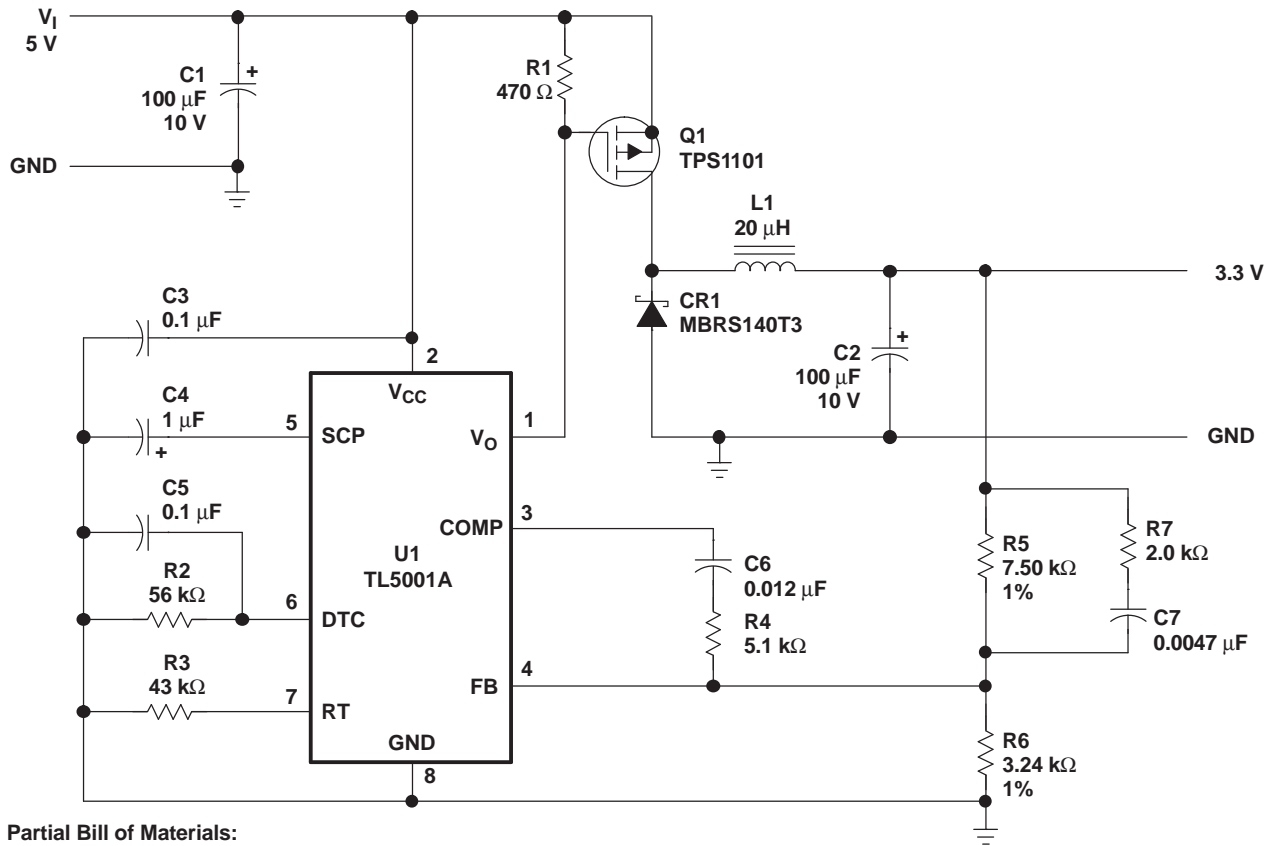

Figure 20.

APPLICATION INFORMATION



Partial Bill of Materials:

U1	TL5001A	Texas Instruments
Q1	TPS1101	Texas Instruments
LI	CTX20-1 or 23 turns of #28 wire on Micrometals No. T50-26B core	Coiltronics
C1	TPSD107M010R0100	AVX
C2	TPSD107M010R0100	AVX
CR1	MBRS140T3	Motorola

- A. Frequency = 200 kHz
- B. Duty cycle = 90% max
- C. Soft-start time constant (TC) = 5.6 ms
- D. SCP TC = 70 ms

Figure 21. Step Down Converter

PACKAGING INFORMATION

Orderable Device	Status (1)	Package Type	Package Drawing	Pins	Package Qty	Eco Plan (2)	Lead/Ball Finish (6)	MSL Peak Temp (3)	Op Temp (°C)	Device Marking (4/5)	Samples
TL5001AQDRG4Q1	ACTIVE	SOIC	D	8	2500	Green (RoHS & no Sb/Br)	NIPDAU	Level-1-260C-UNLIM	-40 to 125	501AQ1	Samples
TL5001AQDRQ1	ACTIVE	SOIC	D	8	2500	Green (RoHS & no Sb/Br)	NIPDAU	Level-1-260C-UNLIM	-40 to 125	501AQ1	Samples

(1) The marketing status values are defined as follows:

ACTIVE: Product device recommended for new designs.

LIFEBUY: TI has announced that the device will be discontinued, and a lifetime-buy period is in effect.

NRND: Not recommended for new designs. Device is in production to support existing customers, but TI does not recommend using this part in a new design.

PREVIEW: Device has been announced but is not in production. Samples may or may not be available.

OBsolete: TI has discontinued the production of the device.

(2) **RoHS:** TI defines "RoHS" to mean semiconductor products that are compliant with the current EU RoHS requirements for all 10 RoHS substances, including the requirement that RoHS substance do not exceed 0.1% by weight in homogeneous materials. Where designed to be soldered at high temperatures, "RoHS" products are suitable for use in specified lead-free processes. TI may reference these types of products as "Pb-Free".

RoHS Exempt: TI defines "RoHS Exempt" to mean products that contain lead but are compliant with EU RoHS pursuant to a specific EU RoHS exemption.

Green: TI defines "Green" to mean the content of Chlorine (Cl) and Bromine (Br) based flame retardants meet JS709B low halogen requirements of <=1000ppm threshold. Antimony trioxide based flame retardants must also meet the <=1000ppm threshold requirement.

(3) MSL, Peak Temp. - The Moisture Sensitivity Level rating according to the JEDEC industry standard classifications, and peak solder temperature.

(4) There may be additional marking, which relates to the logo, the lot trace code information, or the environmental category on the device.

(5) Multiple Device Markings will be inside parentheses. Only one Device Marking contained in parentheses and separated by a "~" will appear on a device. If a line is indented then it is a continuation of the previous line and the two combined represent the entire Device Marking for that device.

(6) Lead/Ball Finish - Orderable Devices may have multiple material finish options. Finish options are separated by a vertical ruled line. Lead/Ball Finish values may wrap to two lines if the finish value exceeds the maximum column width.

Important Information and Disclaimer:The information provided on this page represents TI's knowledge and belief as of the date that it is provided. TI bases its knowledge and belief on information provided by third parties, and makes no representation or warranty as to the accuracy of such information. Efforts are underway to better integrate information from third parties. TI has taken and continues to take reasonable steps to provide representative and accurate information but may not have conducted destructive testing or chemical analysis on incoming materials and chemicals. TI and TI suppliers consider certain information to be proprietary, and thus CAS numbers and other limited information may not be available for release.

In no event shall TI's liability arising out of such information exceed the total purchase price of the TI part(s) at issue in this document sold by TI to Customer on an annual basis.

OTHER QUALIFIED VERSIONS OF TL5001A-Q1 :

- Catalog: [TL5001A](#)
- Military: [TL5001AM](#)

NOTE: Qualified Version Definitions:

- Catalog - TI's standard catalog product
- Military - QML certified for Military and Defense Applications



D0008A

PACKAGE OUTLINE

SOIC - 1.75 mm max height

SMALL OUTLINE INTEGRATED CIRCUIT



4214825/C 02/2019

NOTES:

- Linear dimensions are in inches [millimeters]. Dimensions in parenthesis are for reference only. Controlling dimensions are in inches. Dimensioning and tolerancing per ASME Y14.5M.
- This drawing is subject to change without notice.
- This dimension does not include mold flash, protrusions, or gate burrs. Mold flash, protrusions, or gate burrs shall not exceed $.006$ [0.15] per side.
- This dimension does not include interlead flash.
- Reference JEDEC registration MS-012, variation AA.

EXAMPLE BOARD LAYOUT

D0008A

SOIC - 1.75 mm max height

SMALL OUTLINE INTEGRATED CIRCUIT



LAND PATTERN EXAMPLE
EXPOSED METAL SHOWN
SCALE:8X



SOLDER MASK DETAILS

4214825/C 02/2019

NOTES: (continued)

6. Publication IPC-7351 may have alternate designs.

7. Solder mask tolerances between and around signal pads can vary based on board fabrication site.

EXAMPLE STENCIL DESIGN

D0008A

SOIC - 1.75 mm max height

SMALL OUTLINE INTEGRATED CIRCUIT



SOLDER PASTE EXAMPLE
BASED ON .005 INCH [0.125 MM] THICK STENCIL
SCALE:8X

4214825/C 02/2019

NOTES: (continued)

8. Laser cutting apertures with trapezoidal walls and rounded corners may offer better paste release. IPC-7525 may have alternate design recommendations.
9. Board assembly site may have different recommendations for stencil design.

IMPORTANT NOTICE AND DISCLAIMER

TI PROVIDES TECHNICAL AND RELIABILITY DATA (INCLUDING DATASHEETS), DESIGN RESOURCES (INCLUDING REFERENCE DESIGNS), APPLICATION OR OTHER DESIGN ADVICE, WEB TOOLS, SAFETY INFORMATION, AND OTHER RESOURCES "AS IS" AND WITH ALL FAULTS, AND DISCLAIMS ALL WARRANTIES, EXPRESS AND IMPLIED, INCLUDING WITHOUT LIMITATION ANY IMPLIED WARRANTIES OF MERCHANTABILITY, FITNESS FOR A PARTICULAR PURPOSE OR NON-INFRINGEMENT OF THIRD PARTY INTELLECTUAL PROPERTY RIGHTS.

These resources are intended for skilled developers designing with TI products. You are solely responsible for (1) selecting the appropriate TI products for your application, (2) designing, validating and testing your application, and (3) ensuring your application meets applicable standards, and any other safety, security, or other requirements. These resources are subject to change without notice. TI grants you permission to use these resources only for development of an application that uses the TI products described in the resource. Other reproduction and display of these resources is prohibited. No license is granted to any other TI intellectual property right or to any third party intellectual property right. TI disclaims responsibility for, and you will fully indemnify TI and its representatives against, any claims, damages, costs, losses, and liabilities arising out of your use of these resources.

TI's products are provided subject to TI's Terms of Sale (www.ti.com/legal/termsofsale.html) or other applicable terms available either on ti.com or provided in conjunction with such TI products. TI's provision of these resources does not expand or otherwise alter TI's applicable warranties or warranty disclaimers for TI products.

Mailing Address: Texas Instruments, Post Office Box 655303, Dallas, Texas 75265
Copyright © 2020, Texas Instruments Incorporated