

## LM25061 Positive Low Voltage Power Limiting Hot Swap Controller

Check for Samples: [LM25061](#)

### FEATURES

- Operating Range: +2.9V to +17V
- In-rush Current Limit for Safe Board Insertion into Live Power Sources
- Programmable Maximum Power Dissipation in the External Pass Device
- Adjustable Current Limit
- Circuit Breaker Function for Severe Over-Current Events
- Internal High Side Charge Pump and Gate Driver for External N-Channel MOSFET
- Adjustable Under-Voltage Lockout (UVLO) and Hysteresis
- Adjustable Output Voltage Monitoring and Hysteresis
- Initial Insertion Timer Allows Ringing and Transients to Subside After System Connection
- Programmable Fault Timer Avoids Nuisance Trips
- Active High Open Drain POWER GOOD Output
- Available in Latched Fault and Automatic Restart Versions

### APPLICATIONS

- Server Backplane Systems
- Base Station Power Distribution Systems
- Solid State Circuit Breaker

### PACKAGE

- VSSOP-10

### DESCRIPTION

The LM25061 positive hot swap controller provides intelligent control of the power supply voltage to the load during insertion and removal of circuit cards from a live system backplane or other "hot" power sources. The LM25061 provides in-rush current control to limit system voltage droop and transients. The current limit and power dissipation in the external series pass N-Channel MOSFET are programmable, ensuring operation within the Safe Operating Area (SOA). The POWER GOOD output indicates when the output voltage exceeds a programmable threshold. The input under-voltage level and hysteresis are programmable, as well as the initial insertion delay time and fault detection time. The LM25061-1 latches off after a fault detection, while the LM25061-2 automatically restarts at a fixed duty cycle. The LM25061 is available in a 10 pin VSSOP package.

### Typical Application

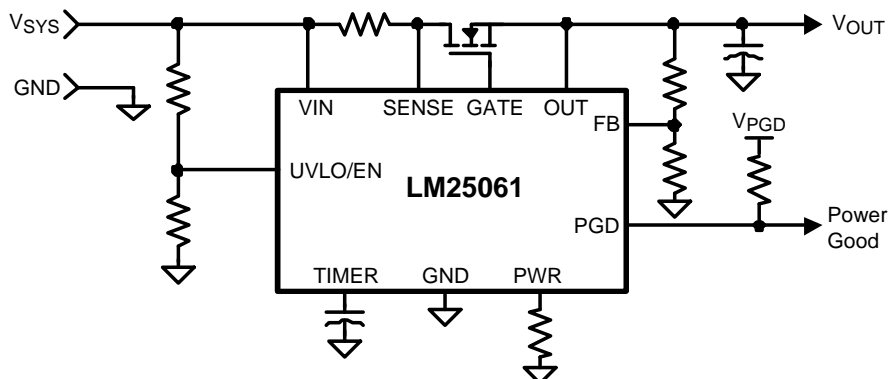

Figure 1. Positive Power Supply Control



Please be aware that an important notice concerning availability, standard warranty, and use in critical applications of Texas Instruments semiconductor products and disclaimers thereto appears at the end of this data sheet.

All trademarks are the property of their respective owners.

## Connection Diagram

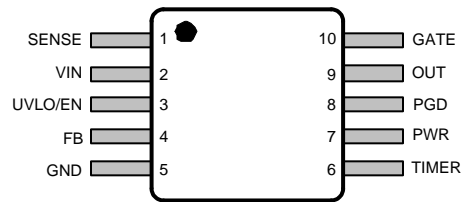

**Figure 2. Top View  
10-Lead VSSOP**

### PIN DESCRIPTIONS

Pin #	Name	Description	Applications Information
1	SENSE	Current sense input	The voltage across the current sense resistor ( $R_S$ ) is measured from VIN to this pin. If the voltage across $R_S$ reaches 50mV the load current is limited and the fault timer activates.
2	VIN	Positive supply input	A small ceramic bypass capacitor close to this pin is recommended to suppress transients which occur when the load current is switched off.
3	UVLO/EN	Under-voltage lockout	An external resistor divider from the system input voltage sets the under-voltage turn-on threshold. An internal 20 $\mu$ A current source provides hysteresis. The enable threshold at the pin is 1.17V. This pin can also be used for remote shutdown control.
4	FB	Output feedback	An external resistor divider from the output sets the output voltage at which the PGD pin switches. The threshold at the pin is 1.17V. An internal 22 $\mu$ A current source provides hysteresis.
5	GND	Circuit ground	
6	TIMER	Timing capacitor	An external capacitor connected to this pin sets the insertion time delay and the Fault Timeout Period. The capacitor also sets the restart timing of the LM25061-2.
7	PWR	Power limit set	An external resistor connected to this pin, in conjunction with the current sense resistor ( $R_S$ ), sets the maximum power dissipation allowed in the external series pass MOSFET.
8	PGD	Power Good indicator	An open drain output. This output is high when the voltages at the FB pin and at the UVLO pin are above their thresholds.
9	OUT	Output feedback	Connect to the output rail (external MOSFET source). Internally used to determine the MOSFET $V_{DS}$ voltage for power limiting.
10	GATE	Gate drive output	Connect to the external MOSFET's gate. This pin's voltage is limited at 19.5V above ground.



These devices have limited built-in ESD protection. The leads should be shorted together or the device placed in conductive foam during storage or handling to prevent electrostatic damage to the MOS gates.

**Absolute Maximum Ratings<sup>(1)(2)(3)</sup>**

VIN to GND <sup>(4)</sup>		-0.3V to 20V
SENSE, OUT, PGD to GND		-0.3V to 20V
UVLO to GND		-0.3V to 20V
FB to GND		-0.3V to 20V
VIN to SENSE		-0.3V to +0.3V
ESD Rating <sup>(5)</sup>	Human Body Model	2kV
Storage Temperature		-65°C to +150°C
Junction Temperature		+150°C
Lead Temperature (soldering 4 sec)		+260°C

- (1) Absolute Maximum Ratings indicate limits beyond which damage to the device may occur. Operating Ratings indicate conditions for which the device is intended to be functional, but do not ensure specific performance limits. For ensured specifications and conditions see the Electrical Characteristics.
- (2) If Military/Aerospace specified devices are required, please contact the TI Sales Office/ Distributors for availability and specifications.
- (3) For detailed information on soldering plastic VSSOP packages refer to the Packaging Databook available from Texas Instruments.
- (4) Current out of a pin is indicated as a negative number.
- (5) The human body model is a 100 pF capacitor discharged through a 1.5 kΩ resistor into each pin.

**Operating Ratings**

VIN Supply Voltage	+2.9V to 17V
PGD Off Voltage	0V to 17V
Junction Temp. Range	-40°C to +85°C

**Electrical Characteristics**

Limits in standard type are for  $T_J = 25^\circ\text{C}$  only; limits in boldface type apply over the junction temperature ( $T_J$ ) range of  $-40^\circ\text{C}$  to  $+85^\circ\text{C}$ . Minimum and Maximum limits are ensured through test, design, or statistical correlation. Typical values represent the most likely parametric norm at  $T_J = 25^\circ\text{C}$ , and are provided for reference purposes only. Unless otherwise stated the following conditions apply:  $V_{IN} = 12\text{V}$ .

Symbol	Parameter	Conditions	Min.	Typ.	Max.	Units
<b>Input (VIN pin)</b>						
$I_{IN-EN}$	Input Current, enabled	UVLO = 2V, $V_{IN} = 14\text{V}$		1.6	<b>2.4</b>	mA
$I_{IN-DIS}$	Input Current, disabled	UVLO = 0.7V		1.0	<b>1.6</b>	mA
POR	Power On Reset threshold at VIN	VIN Increasing		2.6	<b>2.8</b>	V
$POR_{HYS}$	POR hysteresis	VIN decreasing		150		mV
<b>OUT pin</b>						
$I_{OUT-EN}$	OUT bias current, enabled	OUT = VIN, Normal operation		0.30		$\mu\text{A}$
$I_{OUT-DIS}$	OUT bias current, disabled <sup>(1)</sup>	Disabled, OUT = 0V, SENSE = VIN		-12		
<b>UVLO pin</b>						
$UVLO_{TH}$	UVLO threshold		<b>1.154</b>	1.17	<b>1.183</b>	V
$UVLO_{HYS}$	UVLO hysteresis current	UVLO = 1V	<b>15</b>	20	<b>26</b>	$\mu\text{A}$
$UVLO_{DEL}$	UVLO delay	Delay to GATE high		15		$\mu\text{s}$
		Delay to GATE low		8.3		
$UVLO_{BIAS}$	UVLO bias current	UVLO = 3V			<b>1</b>	$\mu\text{A}$
<b>Power Limit (PWR pin)</b>						
$PWR_{LIM-1}$	Power limit sense voltage (VIN-SENSE)	SENSE-OUT = 12V, $R_{PWR} = 69.8\text{ k}\Omega$	<b>19</b>	25	<b>31</b>	mV
$PWR_{LIM-2}$		SENSE-OUT = 6V, $R_{PWR} = 34.8\text{ k}\Omega$	<b>19</b>	25	<b>31</b>	mV
$I_{PWR}$	PWR pin current	$V_{PWR} = 2.5\text{V}$		-15		$\mu\text{A}$
$R_{SAT(PWR)}$	PWR pin impedance when disabled	UVLO = 0.7V		140		$\Omega$

- (1) OUT bias current (disabled) due to leakage current through an internal 1.0 MΩ resistance from SENSE to VOUT.

## Electrical Characteristics (continued)

Limits in standard type are for  $T_J = 25^\circ\text{C}$  only; limits in boldface type apply over the junction temperature ( $T_J$ ) range of  $-40^\circ\text{C}$  to  $+85^\circ\text{C}$ . Minimum and Maximum limits are ensured through test, design, or statistical correlation. Typical values represent the most likely parametric norm at  $T_J = 25^\circ\text{C}$ , and are provided for reference purposes only. Unless otherwise stated the following conditions apply:  $V_{IN} = 12\text{V}$ .

Symbol	Parameter	Conditions	Min.	Typ.	Max.	Units
<b>Gate Control (GATE pin)</b>						
$I_{GATE}$	Source current	Normal Operation	<b>-27</b>	-20	<b>-13</b>	$\mu\text{A}$
	Sink current	UVLO = 1V	<b>1.5</b>	2	<b>2.7</b>	$\text{mA}$
		VIN - SENSE = 150 mV or VIN < POR, $V_{GATE} = 5\text{V}$	<b>160</b>	260	<b>375</b>	$\text{mA}$
$V_{GATE}$	Gate output voltage in normal operation	GATE voltage with respect to ground	<b>18</b>	19.5	<b>21</b>	V
<b>Current Limit</b>						
$V_{CL}$	Threshold voltage	VIN-SENSE voltage	<b>45</b>	50	<b>55</b>	mV
$t_{CL}$	Response time	VIN-SENSE stepped from 0 mV to 80 mV		15		$\mu\text{s}$
$I_{SENSE}$	SENSE input current	Enabled, SENSE = OUT		23		$\mu\text{A}$
		Disabled, OUT = 0V		12		
		Enabled, OUT = 0V		62		
<b>Circuit Breaker</b>						
$V_{CB}$	Threshold voltage	VIN - SENSE	<b>75</b>	95	<b>110</b>	mV
$t_{CB}$	Response time	VIN - SENSE stepped from 0 mV to 150 mV, time to GATE low, no load		0.19	<b>0.36</b>	$\mu\text{s}$
<b>Timer (TIMER pin)</b>						
$V_{TMRH}$	Upper threshold		<b>1.60</b>	1.72	<b>1.85</b>	V
$V_{TMRL}$	Lower threshold	Restart cycles (LM25061-2)	<b>0.9</b>	1.0	<b>1.1</b>	V
		End of 8th cycle (LM25061-2)		0.3		V
		Re-enable Threshold (LM25061-1)		0.3		V
$I_{TIMER}$	Insertion time current		<b>-7.5</b>	-5.5	<b>-3.5</b>	$\mu\text{A}$
	Sink current, end of insertion time	TIMER pin = 2V	<b>1.5</b>	2	<b>2.5</b>	$\text{mA}$
	Fault detection current		<b>-110</b>	-80	<b>-50</b>	$\mu\text{A}$
	Fault sink current		<b>1.6</b>	2.5	<b>3.4</b>	$\mu\text{A}$
$DC_{FAULT}$	Fault Restart Duty Cycle	LM25061-2 only		0.67		%
$t_{FAULT}$	Fault to GATE low delay	TIMER pin reaches the upper threshold		20		$\mu\text{s}$
<b>FB Pin</b>						
$FB_{TH}$	FB threshold	UVLO = 2V	<b>1.145</b>	1.17	<b>1.195</b>	V
$FB_{HYS}$	FB hysteresis current	FB = 2V	<b>-28</b>	-22	<b>-17</b>	$\mu\text{A}$
$FB_{DEL}$	FB delay	Delay to PGD high		100		ns
		Delay to PGD low		110		
$FB_{BIAS}$	FB bias current	FB = 1V			<b>1</b>	$\mu\text{A}$
<b>Power Good (PGD pin)</b>						
$PGD_{VOL}$	Output low voltage	$I_{SINK} = 2\text{mA}$		15	<b>30</b>	mV
$PGD_{IOH}$	Off leakage current	$V_{PGD} = 17\text{V}$			<b>1</b>	$\mu\text{A}$

### Typical Performance Characteristics

Unless otherwise specified the following conditions apply:  $T_J = 25^\circ\text{C}$ ,  $V_{IN} = 12\text{V}$

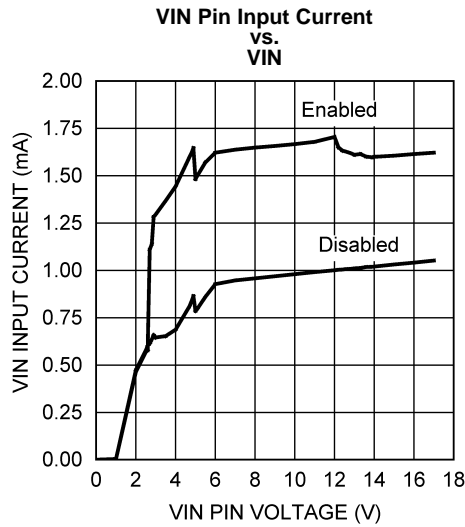

Figure 3.

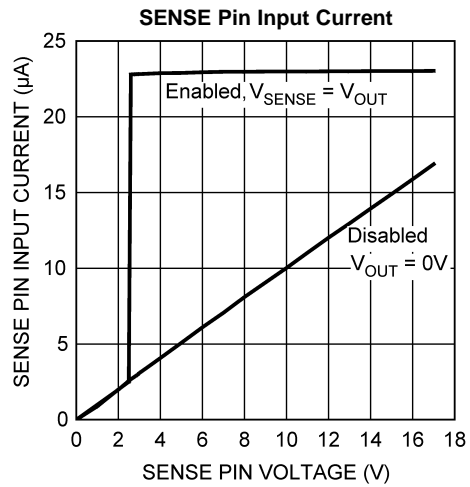

Figure 4.

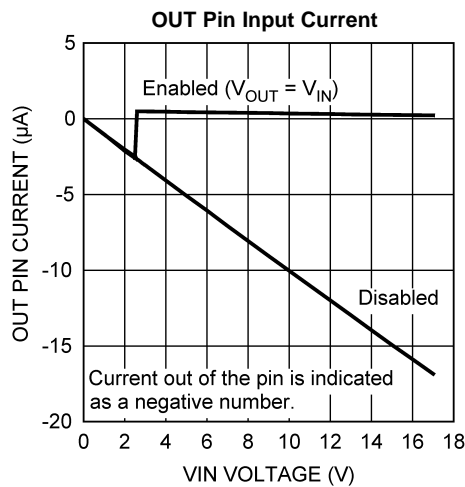

Figure 5.

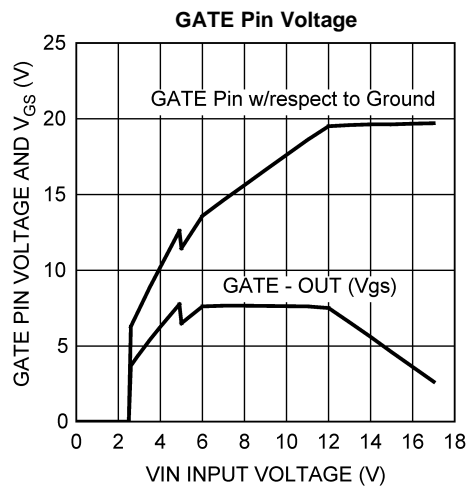

Figure 6.

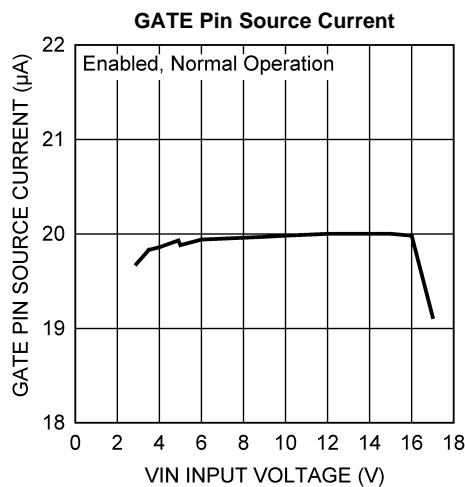

Figure 7.

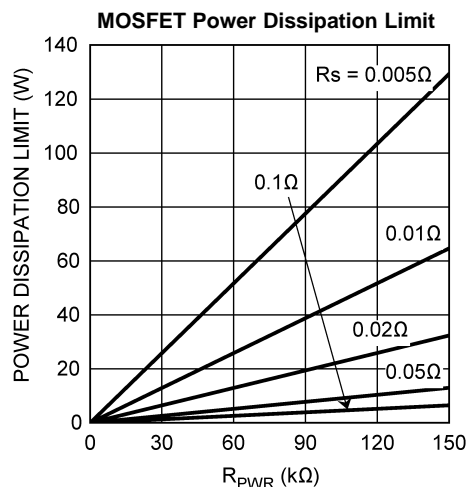

Figure 8.

**Typical Performance Characteristics (continued)**

Unless otherwise specified the following conditions apply:  $T_J = 25^\circ\text{C}$ ,  $V_{IN} = 12\text{V}$

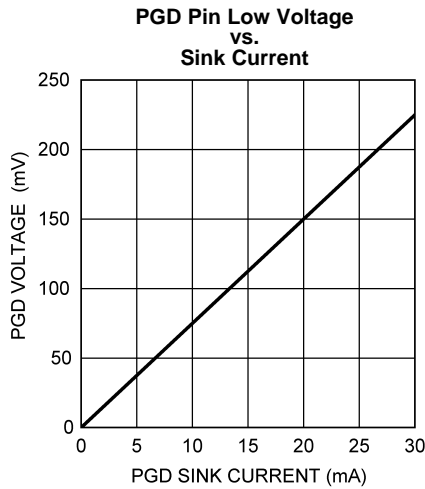

Figure 9.

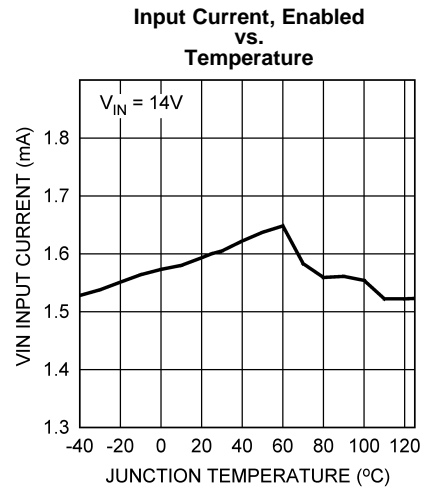

Figure 10.

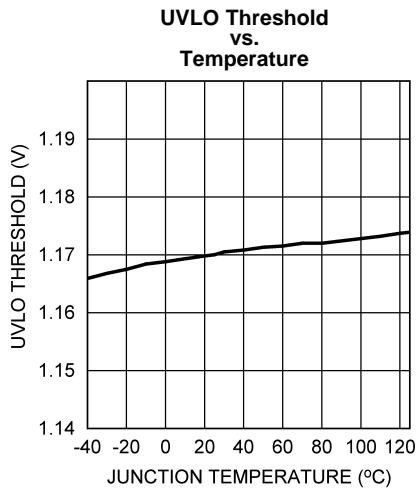

Figure 11.

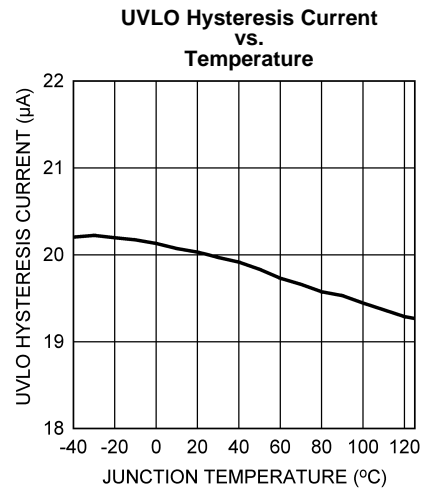

Figure 12.

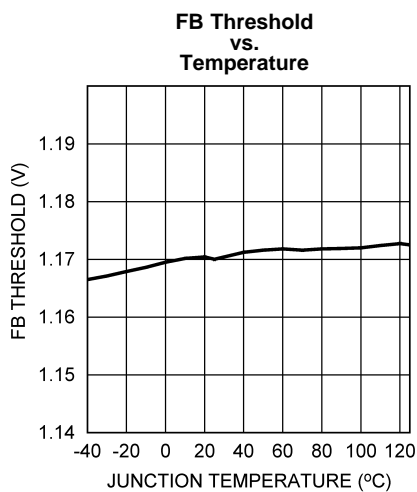

Figure 13.

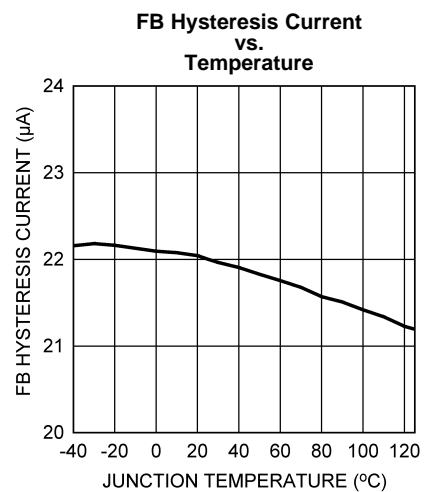

Figure 14.

### Typical Performance Characteristics (continued)

Unless otherwise specified the following conditions apply:  $T_J = 25^\circ\text{C}$ ,  $V_{IN} = 12\text{V}$

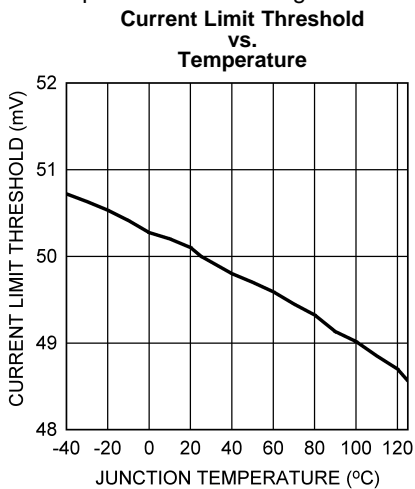

Figure 15.

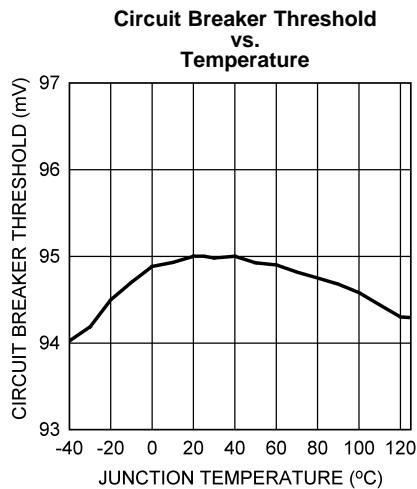

Figure 16.

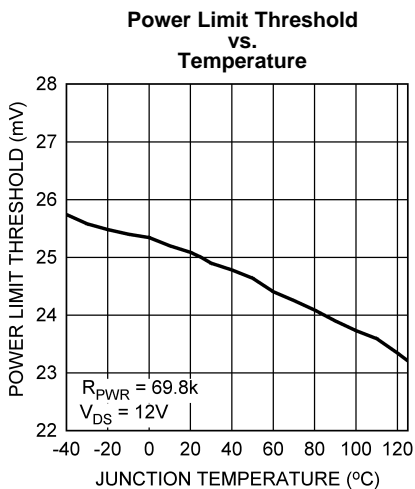

Figure 17.

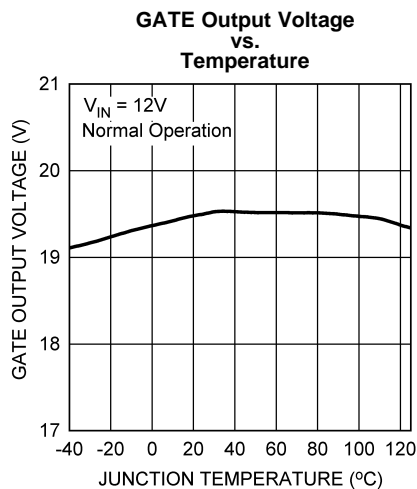

Figure 18.

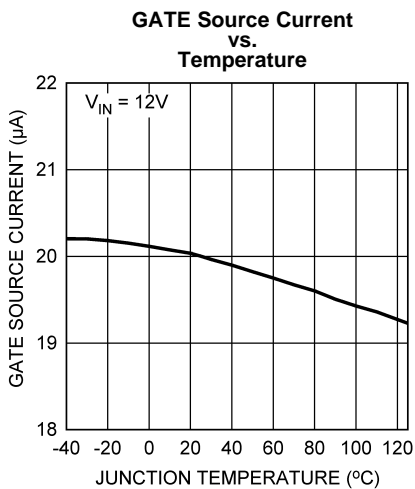

Figure 19.

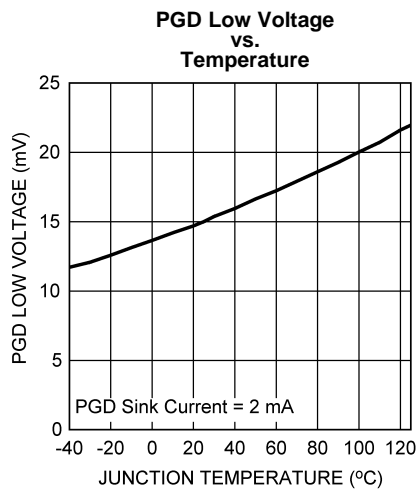

Figure 20.

Block Diagram

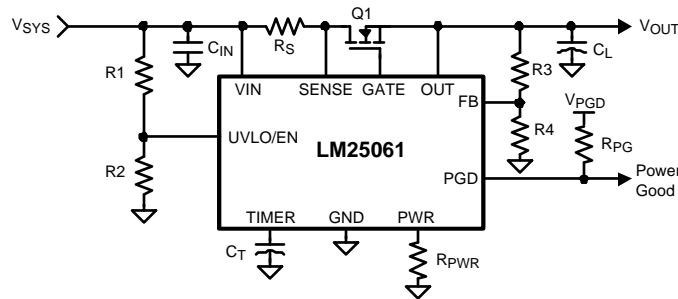
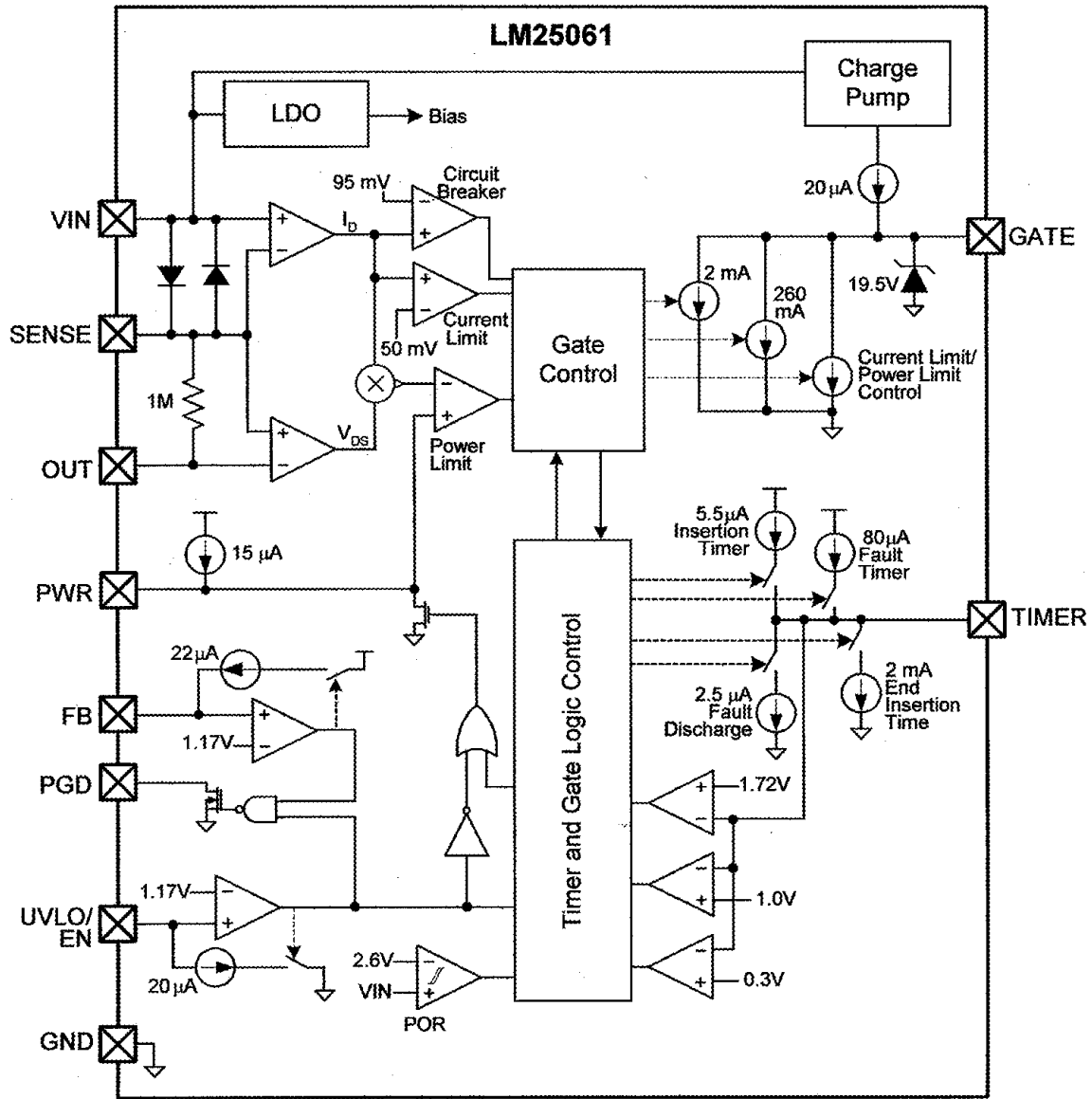

Figure 21. Basic Application Circuit



## Functional Description

The LM25061 is designed to control the in-rush current to the load upon insertion of a circuit card into a live backplane or other "hot" power source, thereby limiting the voltage sag on the backplane's supply voltage, and the  $dV/dt$  of the voltage applied to the load. Effects on other circuits in the system are minimized, preventing possible unintended resets. A controlled shutdown when the circuit card is removed can also be implemented using the LM25061. In addition to a programmable current limit, the LM25061 monitors and limits the maximum power dissipation in the series pass device to maintain operation within the device Safe Operating Area (SOA). Either current limiting or power limiting for an extended period of time results in the shutdown of the series pass device. In this event, the LM25061-1 latches off until the circuit is re-enabled by external control, while the LM25061-2 automatically restarts with defined timing. The circuit breaker function quickly switches off the series pass device upon detection of a severe over-current condition. The Power Good (PGD) output pin indicates when the output voltage is above the programmed threshold. A programmable under-voltage lock-out (UVLO) circuit enables the LM25061 when the system input voltage is above the desired threshold. The typical configuration of a circuit card with LM25061 hot swap protection is shown in Figure 22.

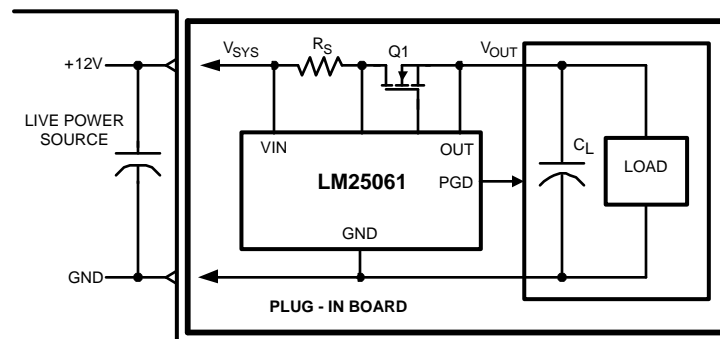

Figure 22. LM25061 Application

## Power Up Sequence

The VIN operating range of the LM25061 is +2.9V to +17V, with a transient capability to 20V. Referring to the Block Diagram and Figure 21 and Figure 23, as the voltage at VIN initially increases, the external N-channel MOSFET (Q1) is held off by an internal 260 mA pull-down current at the GATE pin. The strong pull-down current at the GATE pin prevents an inadvertent turn-on as the MOSFET's gate-to-drain (Miller) capacitance is charged. Additionally, the TIMER pin is initially held at ground. When the VIN voltage reaches the POR threshold the insertion time begins. During the insertion time, the capacitor at the TIMER pin ( $C_T$ ) is charged by a 5.5  $\mu$ A current source, and Q1 is held off by a 2 mA pull-down current at the GATE pin regardless of the VIN voltage. The insertion time delay allows ringing and transients at VIN to settle before Q1 is enabled. The insertion time ends when the TIMER pin voltage reaches 1.72V.  $C_T$  is then quickly discharged by an internal 2 mA pull-down current. The GATE pin then switches on Q1 when  $V_{SYS}$  exceeds the UVLO threshold. If  $V_{SYS}$  is above the UVLO threshold at the end of the insertion time, Q1 switches on at that time. The GATE pin charge pump sources 20  $\mu$ A to charge Q1's gate capacitance. The maximum voltage at the GATE pin is limited by an internal 19.5V zener diode.

As the voltage at the OUT pin increases, the LM25061 monitors the drain current and power dissipation of MOSFET Q1. In-rush current limiting and/or power limiting circuits actively control the current delivered to the load. During the in-rush limiting interval ( $t_2$  in Figure 23) an internal 80  $\mu$ A fault timer current source charges  $C_T$ . If Q1's power dissipation and the input current reduce below their respective limiting thresholds before the TIMER pin reaches 1.72V the 80  $\mu$ A current source is switched off, and  $C_T$  is discharged by the internal 2.5  $\mu$ A current sink ( $t_3$  in Figure 23). The in-rush limiting interval is complete when the load current reduces to the normal operating level. The PGD pin switches high when the output voltage exceeds the threshold programmed at the FB pin.

If the TIMER pin voltage reaches 1.72V before in-rush current limiting or power limiting ceases (during  $t_2$ ), a fault is declared and Q1 is turned off. See the Fault Timer & Restart section for a complete description of the fault mode.

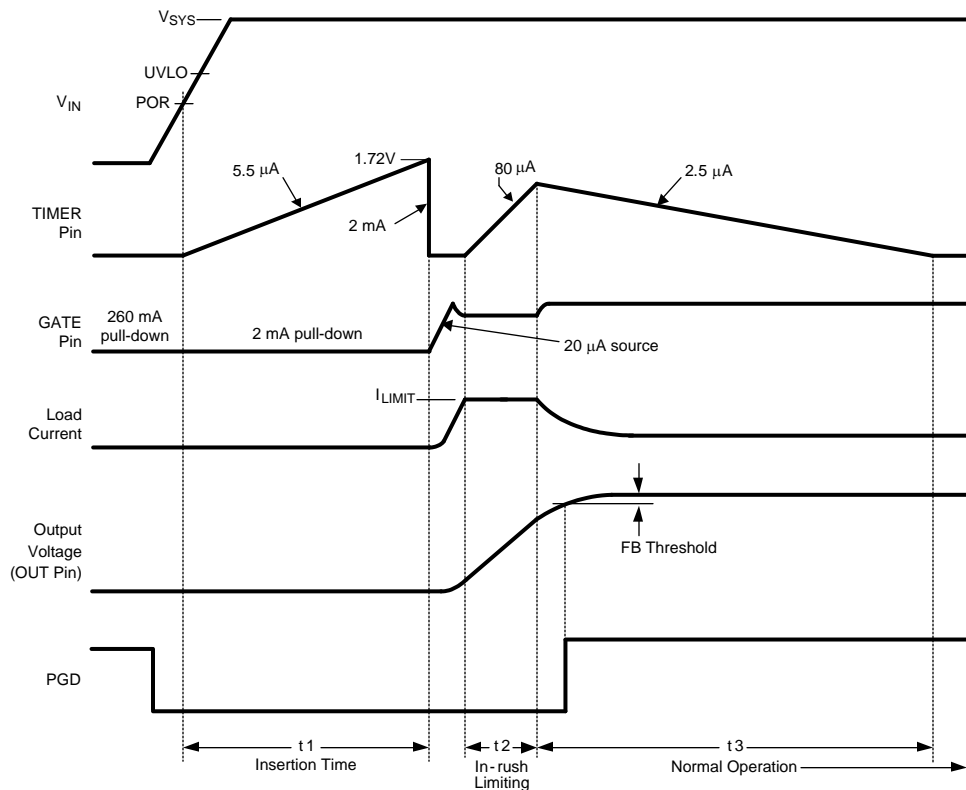

**Figure 23. Power Up Sequence (Current Limit only)**

## Gate Control

A charge pump provides the voltage at the GATE pin to enhance the N-Channel MOSFET's gate. During normal operating conditions ( $t_3$  in [Figure 23](#)) the gate of Q1 is held charged by an internal  $20\ \mu\text{A}$  current source. The voltage at the GATE pin (with respect to ground) is limited by an internal  $19.5\text{V}$  zener diode. See the graph "[GATE Pin Voltage](#)". Since the gate-to-source voltage applied to Q1 could be as high as  $19.5\text{V}$  during various conditions, a zener diode with the appropriate voltage rating must be added between the GATE and OUT pins if the maximum  $V_{GS}$  rating of the selected MOSFET is less than  $19.5\text{V}$ . The external zener diode must have a forward current rating of at least  $260\ \text{mA}$ .

When the system voltage is initially applied, the GATE pin is held low by a  $260\ \text{mA}$  pull-down current. This helps prevent an inadvertent turn-on of the MOSFET through its drain-gate capacitance as the applied system voltage increases.

During the insertion time ( $t_1$  in [Figure 23](#)) the GATE pin is held low by a  $2\ \text{mA}$  pull-down current. This maintains Q1 in the off-state until the end of  $t_1$ , regardless of the voltage at  $V_{IN}$  or UVLO.

Following the insertion time, during  $t_2$  in [Figure 23](#), the gate voltage of Q1 is modulated to keep the current or power dissipation level from exceeding the programmed levels. While in the current or power limiting mode the TIMER pin capacitor is charging. If the current and power limiting cease before the TIMER pin reaches  $1.72\text{V}$  the TIMER pin capacitor then discharges, and the circuit enters normal operation.

If the in-rush limiting condition persists such that the TIMER pin reached  $1.72\text{V}$  during  $t_2$ , the GATE pin is then pulled low by the  $2\ \text{mA}$  pull-down current. The GATE pin is then held low until either a power up sequence is initiated (LM25061-1), or until the end of the restart sequence (LM25061-2). See the [Fault Timer & Restart](#) section.

If the system input voltage falls below the UVLO threshold, the GATE pin is pulled low by the  $2\ \text{mA}$  pull-down current to switch off Q1.

## Current Limit

The current limit threshold is reached when the voltage across the sense resistor  $R_S$  (VIN to SENSE) reaches 50 mV. In the current limiting condition, the GATE voltage is controlled to limit the current in MOSFET Q1. While the current limit circuit is active, the fault timer is active as described in the [Fault Timer & Restart](#) section. If the load current falls below the current limit threshold before the end of the Fault Timeout Period, the LM25061 resumes normal operation. For proper operation, the  $R_S$  resistor value should be no larger than 200 m $\Omega$ . Higher values may result in instability in the current limit control loop.

## Circuit Breaker

If the load current increases rapidly (e.g., the load is short-circuited) the current in the sense resistor ( $R_S$ ) may exceed the current limit threshold before the current limit control loop is able to respond. If the current exceeds approximately twice the current limit threshold ( $95 \text{ mV}/R_S$ ), Q1 is quickly switched off by the 260 mA pull-down current at the GATE pin, and a Fault Timeout Period begins. When the voltage across  $R_S$  falls below 95 mV the 260 mA pull-down current at the GATE pin is switched off, and the gate voltage of Q1 is then determined by the current limit or the power limit functions. If the TIMER pin reaches 1.72V before the current limiting or power limiting condition ceases, Q1 is switched off by the 2 mA pull-down current at the GATE pin as described in the [Fault Timer & Restart](#) section.

## Power Limit

An important feature of the LM25061 is the MOSFET power limiting. The Power Limit function can be used to maintain the maximum power dissipation of MOSFET Q1 within the device SOA rating. The LM25061 determines the power dissipation in Q1 by monitoring its drain-source voltage (SENSE to OUT), and the drain current through the sense resistor (VIN to SENSE). The product of the current and voltage is compared to the power limit threshold programmed by the resistor at the PWR pin. If the power dissipation reaches the limiting threshold, the GATE voltage is modulated to regulate the current in Q1. While the power limiting circuit is active, the fault timer is active as described in the [Fault Timer & Restart](#) section.

## Fault Timer & Restart

When the current limit or power limit threshold is reached during turn-on or as a result of a fault condition, the gate-to-source voltage of Q1 is modulated to regulate the load current and power dissipation in Q1. When either limiting function is activated, an 80  $\mu\text{A}$  fault timer current source charges the external capacitor ( $C_T$ ) at the TIMER pin as shown in [Figure 25](#) (Fault Timeout Period). If the fault condition subsides during the Fault Timeout Period before the TIMER pin reaches 1.72V, the LM25061 returns to the normal operating mode and  $C_T$  is discharged by the 2.5  $\mu\text{A}$  current sink. If the TIMER pin reaches 1.72V during the Fault Timeout Period, Q1 is switched off by a 2 mA pull-down current at the GATE pin. The subsequent restart procedure then depends on which version of the LM25061 is in use.

The LM25061-1 latches the GATE pin low at the end of the Fault Timeout Period.  $C_T$  is then discharged to ground by the 2.5  $\mu\text{A}$  fault current sink. The GATE pin is held low by the 2 mA pull-down current until a power up sequence is externally initiated by cycling the input voltage ( $V_{\text{SYS}}$ ), or momentarily pulling the UVLO/EN pin below its threshold with an open-collector or open-drain device as shown in [Figure 24](#). The voltage at the TIMER pin must be less than 0.3V for the restart procedure to be effective.

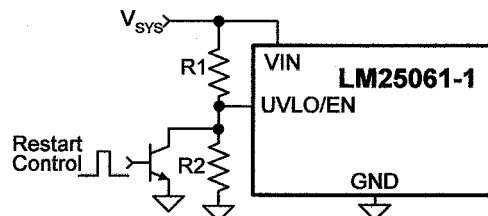
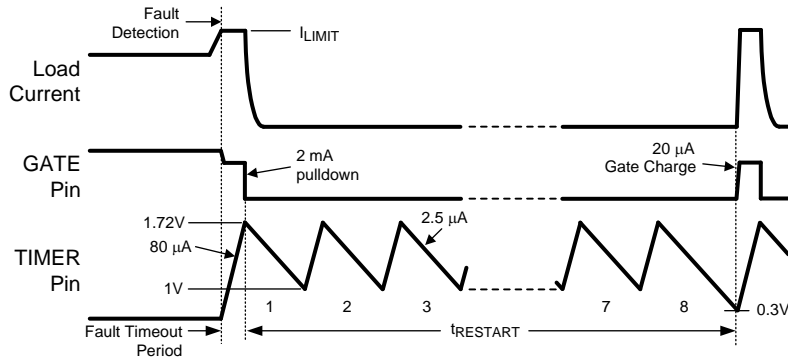

Figure 24. Latched Fault Restart Control

The LM25061-2 provides an automatic restart sequence which consists of the TIMER pin cycling between 1.72V and 1V seven times after the Fault Timeout Period, as shown in Figure 25. The period of each cycle is determined by the 80  $\mu\text{A}$  charging current, and the 2.5  $\mu\text{A}$  discharge current, and the value of the capacitor  $C_T$ . When the TIMER pin reaches 0.3V during the eighth high-to-low ramp, the 20  $\mu\text{A}$  current source at the GATE pin turns on Q1. If the fault condition is still present, the Fault Timeout Period and the restart cycle repeat.

The Fault Timeout Period during restart cycles is approximately 18% shorter than the initial fault timeout period which initiated the restart cycle. This is due to the fact that the TIMER pin transitions from 0.3V to 1.72V after each restart time, rather than from ground.



**Figure 25. Restart Sequence (LM25061-2)**

### Under-Voltage Lock-Out (UVLO)

The series pass MOSFET (Q1) is enabled when the input supply voltage ( $V_{\text{SYS}}$ ) is greater than the programmable under-voltage lockout (UVLO) level. Typically the UVLO level at  $V_{\text{SYS}}$  is set with a resistor divider (R1-R2) as shown in Figure 21. Referring to the Block Diagram when  $V_{\text{SYS}}$  is below the UVLO level, the internal 20  $\mu\text{A}$  current source at UVLO is enabled, and Q1 is held off by the 2 mA pull-down current at the GATE pin. As  $V_{\text{SYS}}$  is increased, raising the voltage at UVLO above its threshold the 20  $\mu\text{A}$  current source at UVLO is switched off, increasing the voltage at UVLO, providing hysteresis for this threshold. With the UVLO pin above its threshold, Q1 is switched on by the 20  $\mu\text{A}$  current source at the GATE pin if the insertion time delay has expired. See the Applications Section for a procedure to calculate the values of the threshold setting resistors (R1-R2). The minimum possible UVLO level at  $V_{\text{SYS}}$  can be set by connecting the UVLO pin to VIN. In this case Q1 is enabled after the insertion time.

### Shutdown Control

The load current can be remotely switched off by taking the UVLO pin below its threshold with an open collector or open drain device, as shown in Figure 26. Upon releasing the UVLO pin the LM25061 switches on the load current with in-rush current and power limiting.

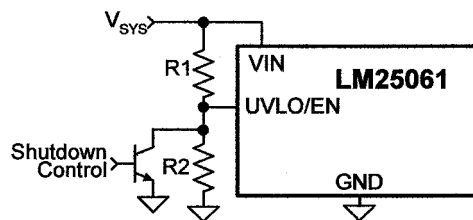

**Figure 26. Shutdown Control**

## Power Good Pin

The Power Good indicator pin (PGD) is connected to the drain of an internal N-channel MOSFET capable of sustaining 17V in the off-state, and transients up to 20V. An external pull-up resistor is required at PGD to an appropriate voltage to indicate the status to downstream circuitry. The off-state voltage at the PGD pin can be higher or lower than the voltages at VIN and OUT. The PGD pin switches high when the voltage at the FB pin exceeds its threshold. Typically the output voltage threshold is set with a resistor divider (R3-R4) as shown in [Figure 21](#), although the monitored voltage need not be the output voltage. Any other voltage can be monitored by connecting R3 to that voltage as long as the voltage at the FB pin does not exceed its maximum rating. Referring to the [Block Diagram](#), when the voltage at the FB pin is below its threshold, the internal 22 µA current source at FB is disabled. As the output voltage increases, taking FB above its threshold, the current source is enabled, sourcing current out of the pin, raising the voltage at FB to provide threshold hysteresis.

The PGD output is low when the UVLO pin is below its threshold. The PGD output is high when the voltage at VIN is less than 1.6V.

## APPLICATION INFORMATION

(Refer to [Figure 21](#))

### CURRENT LIMIT, $R_S$

The LM25061 monitors the current in the external MOSFET (Q1) by measuring the voltage across the sense resistor ( $R_S$ ), connected from VIN to SENSE. The required resistor value is calculated from:

$$R_S = \frac{50 \text{ mV}}{I_{LIM}}$$

where

- $I_{LIM}$  is the desired current limit threshold (1)

If the voltage across  $R_S$  reaches 50 mV, the current limit circuit modulates the gate of Q1 to regulate the current at  $I_{LIM}$ . While the current limiting circuit is active, the fault timer is active as described in the [Fault Timer & Restart](#) section. For proper operation,  $R_S$  must be no larger than 200 mΩ.

While the maximum load current in normal operation can be used to determine the required power rating for resistor  $R_S$ , basing it on the current limit value provides a more reliable design since the circuit can operate near the current limit threshold continuously. The resistor's surge capability must also be considered since the circuit breaker threshold is approximately twice the current limit threshold. Connections from  $R_S$  to the LM25061 should be made using Kelvin techniques. In the suggested layout of [Figure 27](#) the small pads at the lower corners of the sense resistor connect only to the sense resistor terminals, and not to the traces carrying the high current. With this technique, only the voltage across the sense resistor is applied to VIN and SENSE, eliminating the voltage drop across the high current solder connections.

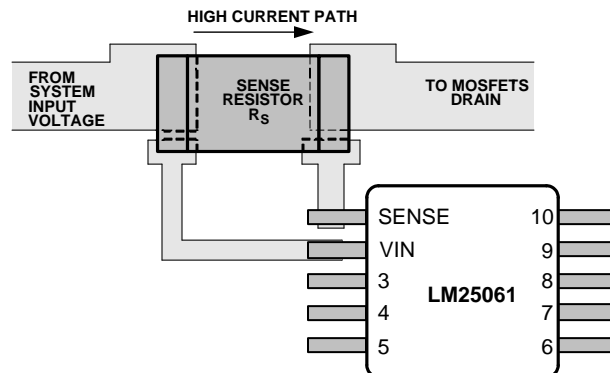

**Figure 27. Sense Resistor Connections**

## POWER LIMIT THRESHOLD

The LM25061 determines the power dissipation in the external MOSFET (Q1) by monitoring the drain current (the current in  $R_S$ ), and the  $V_{DS}$  of Q1 (SENSE to OUT pins). The resistor at the PWR pin ( $R_{PWR}$ ) sets the maximum power dissipation for Q1, and is calculated from the following equation:

$$R_{PWR} = 2.32 \times 10^5 \times R_S \times P_{FET(LIM)}$$

where

- $P_{FET(LIM)}$  is the desired power limit threshold for Q1
- $R_S$  is the current sense resistor described in the [Current Limit](#) section

For example, if  $R_S$  is 10 m $\Omega$ , and the desired power limit threshold is 20W,  $R_{PWR}$  calculates to 46.4 k $\Omega$ . If Q1's power dissipation reaches the threshold Q1's gate is modulated to regulate the load current, keeping Q1's power from exceeding the threshold. For proper operation of the power limiting feature,  $R_{PWR}$  must be  $\leq 150$  k $\Omega$ . While the power limiting circuit is active, the fault timer is active as described in the [Fault Timer & Restart](#) section. Typically, power limit is reached during startup, or if the output voltage falls due to a severe overload or short circuit.

The programmed maximum power dissipation should have a reasonable margin from the maximum power defined by the FET's SOA chart if the LM25061-2 is used since the FET will be repeatedly stressed during fault restart cycles. The FET manufacturer should be consulted for guidelines.

If the application does not require use of the power limit function the PWR pin can be left open.

The accuracy of the power limit function at turn-on may degrade if a very low value power dissipation limit is set. The reason for this caution is that the voltage across the sense resistor, which is monitored and regulated by the power limit circuit, is lowest at turn-on when the regulated current is at minimum. The voltage across the sense resistor during power limit can be expressed as follows:

$$V_{SENSE} = I_L \times R_S = \frac{R_{PWR}}{2.32 \times 10^5 \times V_{DS}} = \frac{R_S \times P_{FET(LIM)}}{V_{DS}}$$

where

- $I_L$  is the current in  $R_S$
- $V_{DS}$  is the voltage across Q1

For example, if the power limit is set at 20W with  $R_S = 10$  mohms, and  $V_{DS} = 15$ V the sense resistor voltage calculates to 13.3 mV, which is comfortably regulated by the LM25061. However, if a lower power limit is set lower (e.g., 2W), the sense resistor voltage calculates to 1.33 mV. At this low level noise and offsets within the LM25061 may degrade the power limit accuracy. To maintain accuracy, the sense resistor voltage should not be less than 5 mV.

## TURN-ON TIME

The output turn-on time depends on whether the LM25061 operates in current limit, or in both power limit and current limit, during turn-on.

**A) Turn-on with current limit only:** The current limit threshold ( $I_{LIM}$ ) is determined by the current sense resistor ( $R_S$ ). If the current limit threshold is less than the current defined by the power limit threshold at maximum  $V_{DS}$  the circuit operates at the current limit threshold only during turn-on. Referring to [Figure 30a](#), as the load current reaches  $I_{LIM}$ , the gate-to-source voltage is controlled at  $V_{GSL}$  to maintain the current at  $I_{LIM}$ . As the output voltage reaches its final value, ( $V_{DS} \approx 0$ V) the drain current reduces to its normal operating value. The time for the OUT pin voltage to transition from zero volts to  $V_{SYS}$  is equal to:

$$t_{ON} = \frac{V_{SYS} \times C_L}{I_{LIM}}$$

where

- $C_L$  is the load capacitance

For example, if  $V_{SYS} = 12V$ ,  $C_L = 1000 \mu F$ , and  $I_{LIM} = 1A$ ,  $t_{ON}$  calculates to 12 ms. The maximum instantaneous power dissipated in the MOSFET is 12W. This calculation assumes the time from  $t_1$  to  $t_2$  in Figure 30a is small compared to  $t_{ON}$ , and the load does not draw any current until after the output voltage has reached its final value, (Figure 28). If the load draws current during the turn-on sequence (Figure 29), the turn-on time is longer than the above calculation, and is approximately equal to:

$$t_{ON} = -(R_L \times C_L) \times \ln \left[ \frac{(I_{LIM} \times R_L) - V_{SYS}}{(I_{LIM} \times R_L)} \right]$$

where

- $R_L$  is the load resistance

(5)

The Fault Timeout Period must be set longer than  $t_{ON}$  to prevent a fault shutdown before the turn-on sequence is complete.

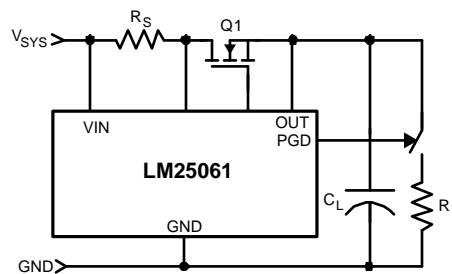

Figure 28. No Load Current During Turn-On

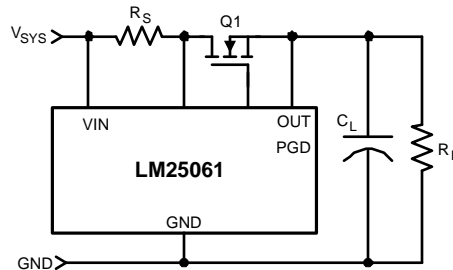

Figure 29. Load Draws Current During Turn-On

**B) Turn-on with power limit and current limit:** The maximum allowed power dissipation in Q1 ( $P_{FET(LIM)}$ ) is defined by the resistor at the PWR pin, and the current sense resistor  $R_S$ . See the [Power Limit Threshold](#) section. If the current limit threshold ( $I_{LIM}$ ) is higher than the current defined by the power limit threshold at maximum  $V_{DS}$  ( $P_{FET(LIM)}/V_{SYS}$ ) the circuit operates initially in the power limit mode when the  $V_{DS}$  of Q1 is high, and then transitions to current limit mode as the current increases to  $I_{LIM}$  and  $V_{DS}$  decreases. See Figure 30b. Assuming the load ( $R_L$ ) is not connected during turn-on, the time for the output voltage to reach its final value is approximately equal to:

$$t_{ON} = \frac{C_L \times V_{SYS}^2}{2 \times P_{FET(LIM)}} + \frac{C_L \times P_{FET(LIM)}}{2 \times I_{LIM}^2}$$

(6)

For example, if  $V_{SYS} = 12V$ ,  $C_L = 1000 \mu F$ ,  $I_{LIM} = 1A$ , and  $P_{FET(LIM)} = 10W$ ,  $t_{ON}$  calculates to  $\approx 12.2$  ms, and the initial current level ( $I_P$ ) is approximately 0.83A. The Fault Timeout Period must be set longer than  $t_{ON}$ .

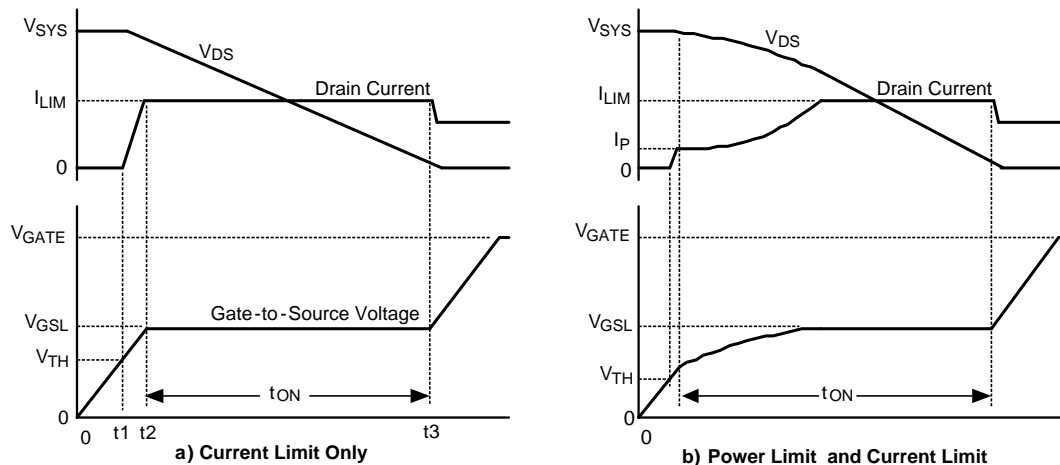

**Figure 30. MOSFET Power Up Waveforms**

## MOSFET SELECTION

It is recommended that the external MOSFET (Q1) selection be based on the following criteria:

- The  $BV_{DSS}$  rating should be greater than the maximum system voltage ( $V_{SYS}$ ), plus ringing and transients which can occur at  $V_{SYS}$  when the circuit card, or adjacent cards, are inserted or removed.
- The maximum continuous current rating should be based on the current limit threshold ( $50 \text{ mV}/R_S$ ), not the maximum load current, since the circuit can operate near the current limit threshold continuously.
- The Pulsed Drain Current spec ( $I_{DM}$ ) must be greater than the current threshold for the circuit breaker function ( $95 \text{ mV}/R_S$ ).
- The SOA (Safe Operating Area) chart of the device, and the thermal properties, should be used to determine the maximum power dissipation threshold set by the  $R_{PWR}$  resistor. The programmed maximum power dissipation should have a reasonable margin from the maximum power defined by the FET's SOA chart if the LM25061-2 is used since the FET will be repeatedly stressed during fault restart cycles. The FET manufacturer should be consulted for guidelines.
- $R_{DS(on)}$  should be sufficiently low that the power dissipation at maximum load current ( $I_{L(max)}^2 \times R_{DS(on)}$ ) does not raise its junction temperature above the manufacturer's recommendation.

If the circuit's input voltage is at the low end of the LM25061's operating range ( $<3.5\text{V}$ ), or at the high end of the operating range ( $>14\text{V}$ ), the gate-to-source voltage applied to the MOSFET by the LM25061 is less than 5V, and can approach 1V in a worst case situation. See the graph "GATE Pin Voltage". The selected device must have a suitable Gate-to-Source Threshold Voltage.

The gate-to-source voltage provided by the LM25061 can be as high as 19.5V at turn-on when the output voltage is zero. At turn-off the reverse gate-to-source voltage will be equal to the output voltage at the instant the GATE pin is pulled low. If the device chosen for Q1 is not rated for these voltages, an external zener diode must be added from its gate to source, with the zener voltage less than the device maximum  $V_{GS}$  rating. The zener diode's working voltage protects the MOSFET during turn-on, and its forward voltage protects the MOSFET during shutoff. The zener diode's forward current rating must be at least 260 mA to conduct the GATE pull-down current when a circuit breaker condition is detected.

## TIMER CAPACITOR, $C_T$

The TIMER pin capacitor ( $C_T$ ) sets the timing for the insertion time delay, fault timeout period, and restart timing of the LM25061-2.

**A) Insertion Delay** - Upon applying the system voltage ( $V_{SYS}$ ) to the circuit, the external MOSFET (Q1) is held off during the insertion time ( $t_1$  in Figure 23) to allow ringing and transients at  $V_{SYS}$  to settle. Since each backplane's response to a circuit card plug-in is unique, the worst case settling time must be determined for each application. The insertion time starts when  $V_{IN}$  reaches the POR threshold, at which time the internal  $5.5 \mu\text{A}$  current source charges  $C_T$  from 0V to 1.72V. The required capacitor value is calculated from:



$$C_T = \frac{t_1 \times 5.5 \mu\text{A}}{1.72\text{V}} = t_1 \times 3.2 \times 10^{-6} \quad (7)$$

For example, if the desired insertion delay is 250 ms,  $C_T$  calculates to 0.8  $\mu\text{F}$ . At the end of the insertion delay,  $C_T$  is quickly discharged by a 2 mA current sink.

**B) Fault Timeout Period** - During in-rush current limiting or upon detection of a fault condition where the current limit and/or power limit circuits regulate the current through Q1, the fault timer current source (80  $\mu\text{A}$ ) switches on to charge  $C_T$ . The Fault Timeout Period is the time required for the voltage at the TIMER pin to transition from ground to 1.72V, at which time Q1 is switched off. If the LM25061-1 is in use, the required capacitor value is calculated from:

$$C_T = \frac{t_{\text{FAULT}} \times 80 \mu\text{A}}{1.72\text{V}} = t_{\text{FAULT}} \times 4.65 \times 10^{-5} \quad (8)$$

For example, if the desired Fault Timeout Period is 17 ms,  $C_T$  calculates to 0.8  $\mu\text{F}$ . When the Fault Timeout Period expires, the LM25061-1 latches the GATE pin low until a power-up sequence is initiated by external circuitry. If the LM25061-2 is in use, the Fault Timeout Period during restart cycles is approximately 18% shorter than the initial fault timeout period which initiated the restart cycles since the voltage at the TIMER pin transitions from 0.3V to 1.72V. Since the Fault Timeout Period must always be longer than the turn-on-time, the required capacitor value for the LM25061-2 is calculated using this shorter time period:

$$C_T = \frac{t_{\text{FAULT}} \times 80 \mu\text{A}}{1.42\text{V}} = t_{\text{FAULT}} \times 5.63 \times 10^{-5} \quad (9)$$

For example, if the desired Fault Timeout Period is 17 ms,  $C_T$  calculates to 0.96  $\mu\text{F}$ . When the Fault Timeout Period of the LM25061-2 expires, a restart sequence starts as described below (Restart Timing). Since the LM25061 normally operates in power limit and/or current limit during a power-up sequence, the Fault Timeout Period **MUST** be longer than the time required for the output voltage to reach its final value. See the [Turn-on Time](#) section

**C) Restart Timing** For the LM25061-2, after the Fault Timeout Period described above,  $C_T$  is discharged by the 2.5  $\mu\text{A}$  current sink to 1.0V. The TIMER pin then cycles through seven additional charge/discharge cycles between 1V and 1.72V as shown in [Figure 25](#). The restart time ends when the TIMER pin voltage reaches 0.3V during the final high-to-low ramp. The restart time, after the Fault Timeout Period, is equal to:

$$t_{\text{RESTART}} = C_T \times \left[ \frac{7 \times 0.72\text{V}}{2.5 \mu\text{A}} + \frac{7 \times 0.72\text{V}}{80 \mu\text{A}} + \frac{1.42\text{V}}{2.5 \mu\text{A}} \right] \\ = C_T \times 2.65 \times 10^6 \quad (10)$$

For example, if  $C_T = 0.8 \mu\text{F}$ ,  $t_{\text{RESTART}} = 2.12$  seconds. At the end of the restart time, Q1 is switched on. If the fault is still present, the fault timeout and restart sequence repeats. The on-time duty cycle of Q1 is approximately 0.67% in this mode.

## UVLO

Programming the UVLO thresholds sets the minimum system voltage to enable the series pass device (Q1). If  $V_{\text{SYS}}$  is below the UVLO thresholds, Q1 is switched off, denying power to the load. Programmable hysteresis is provided.

**Option A:** The UVLO thresholds are set with two resistors (R1, R2) as shown in [Figure 31](#).

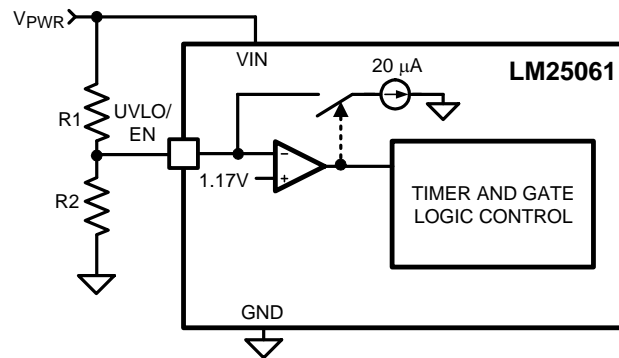

**Figure 31. Programming the UVLO Thresholds**

The two resistor values are calculated as follows:

- Choose the upper and lower UVLO thresholds ( $V_{UVH}$ ) and ( $V_{UVL}$ ).

$$R1 = \frac{V_{UVH} - V_{UVL}}{20 \mu\text{A}} = \frac{V_{UV(HYS)}}{20 \mu\text{A}} \quad (11)$$

$$R2 = \frac{1.17\text{V} \times R1}{V_{UVL} - 1.17\text{V}} \quad (12)$$

As an example, assume the application requires the following thresholds:  $V_{UVH} = 8\text{V}$ ,  $V_{UVL} = 7\text{V}$ . Therefore  $V_{UV(HYS)} = 1\text{V}$ . The resistor values are:

$$R1 = 50 \text{ k}\Omega, R2 = 10 \text{ k}\Omega \quad (13)$$

Where the resistor values are known, the threshold voltages and hysteresis are calculated from the following:

$$V_{UVH} = 1.17\text{V} + [R1 \times \frac{(1.17\text{V} + 20 \mu\text{A})}{R2}] \quad (14)$$

$$V_{UVL} = \frac{1.17\text{V} \times (R1 + R2)}{R2} \quad (15)$$

$$V_{UV(HYS)} = R1 \times 20 \mu\text{A} \quad (16)$$

**Option B:** The minimum UVLO level is obtained by connecting the UVLO pin to VIN as shown in [Figure 32](#). Q1 is switched on when the VIN voltage reaches the POR threshold ( $\approx 2.6\text{V}$ ).

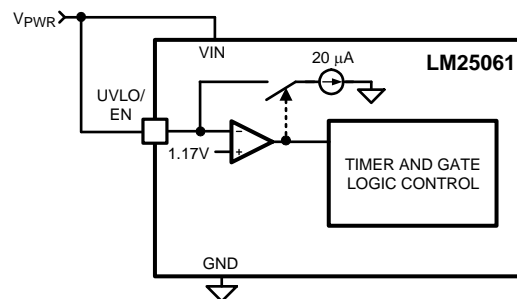

**Figure 32. UVLO = POR**

## POWER GOOD and FB PINS

During turn-on, the Power Good pin (PGD) is high until the voltage at VIN increases above  $\approx 1.6V$ . PGD then switches low, remaining low as the VIN voltage increases. When the voltage at the FB pin increases above its threshold PGD switches low. PGD switches low when the voltage at the FB pin is below the programmed threshold, or if the UVLO pin is taken below its threshold. Setting the output threshold for the PGD pin requires two resistors (R3, R4) as shown in Figure 33. While monitoring the output voltage is shown in Figure 33, R3 can be connected to any other voltage which requires monitoring.

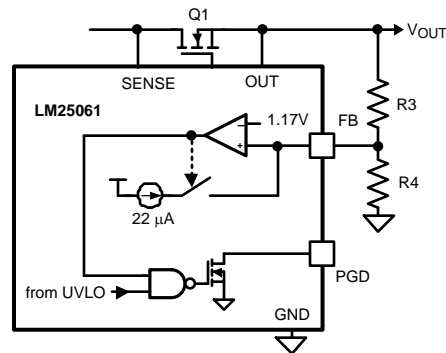

Figure 33. Programming the PGD Threshold

The resistor values are calculated as follows:

- Choose the upper and lower threshold ( $V_{PGDH}$ ) and ( $V_{PGDL}$ ) at  $V_{OUT}$ .

$$R3 = \frac{V_{PGDH} - V_{PGDL}}{22 \mu A} = \frac{V_{PGD(HYS)}}{22 \mu A} \quad (17)$$

$$R4 = \frac{1.17V \times R3}{(V_{PGDH} - 1.17V)} \quad (18)$$

As an example, assume the application requires the following thresholds:  $V_{PGDH} = 11V$ , and  $V_{PGDL} = 10.5V$ . Therefore  $V_{PGD(HYS)} = 0.5V$ . The resistor values are:

$$R3 = 22.7 \text{ k}\Omega, R4 = 2.68 \text{ k}\Omega \quad (19)$$

Where the R3 and R4 resistor values are known, the threshold voltages and hysteresis are calculated from the following:

$$V_{PGDH} = \frac{1.17V \times (R3 + R4)}{R4} \quad (20)$$

$$V_{PGDL} = 1.17V + [R3 \times \frac{(1.17V - 22 \mu A)}{R4}] \quad (21)$$

$$V_{PGD(HYS)} = R3 \times 22 \mu A \quad (22)$$

A pull-up resistor is required at PGD as shown in Figure 34. The pull-up voltage ( $V_{PGD}$ ) can be as high as 17V, and can be higher or lower than the voltages at VIN and OUT.

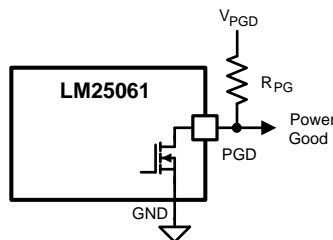

Figure 34. Power Good Output

If a delay is required at PGD, suggested circuits are shown in [Figure 35](#). In [Figure 35a](#), capacitor  $C_{PG}$  adds delay to the rising edge, but not to the falling edge. In [Figure 35b](#), the rising edge is delayed by  $R_{PG1} + R_{PG2}$  and  $C_{PG}$ , while the falling edge is delayed a lesser amount by  $R_{PG2}$  and  $C_{PG}$ . Adding a diode across  $R_{PG2}$  ([Figure 35c](#)) allows for equal delays at the two edges, or a short delay at the rising edge and a long delay at the falling edge.

## Design-in Procedure

The recommended design-in procedure is as follows:

- Determine the current limit threshold ( $I_{LIM}$ ). This threshold must be higher than the normal maximum load current, allowing for tolerances in the current sense resistor value and the LM25061 Current Limit threshold voltage. Use [Equation 1](#) to determine the value for  $R_S$ .
- Determine the maximum allowable power dissipation for the series pass FET (Q1), using the device's SOA information. Use [Equation 2](#) to determine the value for  $R_{PWR}$ .
- Determine the value for the timing capacitor at the TIMER pin ( $C_T$ ) using [Equation 8](#) or [Equation 9](#). The fault timeout period ( $t_{FAULT}$ ) must be longer than the circuit's turn-on-time. The turn-on time can be estimated using the equations in the [TURN-ON TIME](#) section of this data sheet, but should be verified experimentally. Review the resulting insertion time, and restart timing if the LM25061-2 is used.
- Choose option A or B from the [UVLO](#) section of the Application Information for setting the UVLO threshold and hysteresis. Use the procedure for the appropriate option to determine the resistor values at the UVLO pin.
- Choose the appropriate voltage, and pull-up resistor, for the Power Good output.
- Determine the resistor values for the FB pin.

## PC Board Guidelines

The following guidelines should be followed when designing the PC board for the LM25061:

- Place the LM25061 close to the board's input connector to minimize trace inductance from the connector to the FET.
- Place a small capacitor (1000 pF) directly adjacent to the VIN and GND pins of the LM25061 to help minimize transients which may occur on the input supply line. Transients of several volts can easily occur when the load current is shut off.
- The sense resistor ( $R_S$ ) should be close to the LM25061, and connected to it using the Kelvin techniques shown in [Figure 27](#).
- The high current path from the board's input to the load (via Q1), and the return path, should be parallel and close to each other to minimize loop inductance.
- The ground connection for the various components around the LM25061 should be connected directly to each other, and to the LM25061's GND pin, and then connected to the system ground at one point. Do not connect the various component grounds to each other through the high current ground line.
- Provide adequate heat sinking for the series pass device (Q1) to help reduce stresses during turn-on and turn-off.
- The board's edge connector can be designed to shut off the LM25061 as the board is removed, before the supply voltage is disconnected from the LM25061. In [Figure 36](#) the voltage at the UVLO pin goes to ground before  $V_{SYS}$  is removed from the LM25061 due to the shorter edge connector pin. When the board is inserted into the edge connector, the system voltage is applied to the LM25061's VIN pin before the UVLO voltage is taken high.

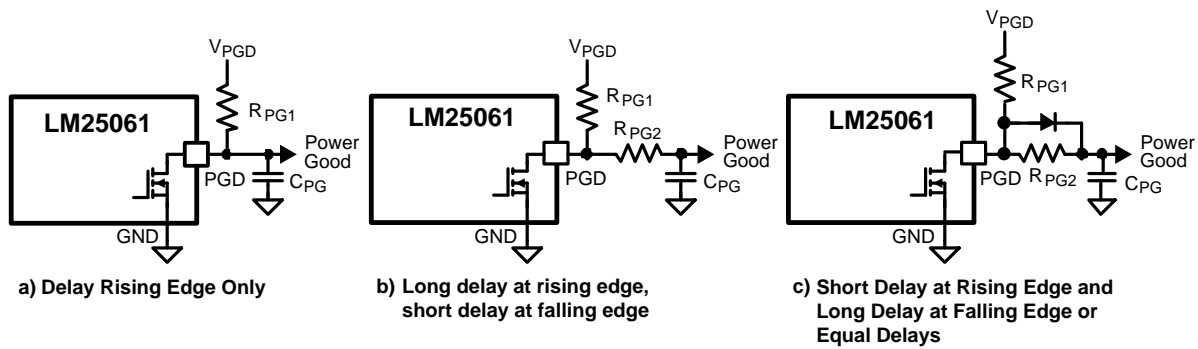

Figure 35. Adding Delay to the Power Good Output Pin

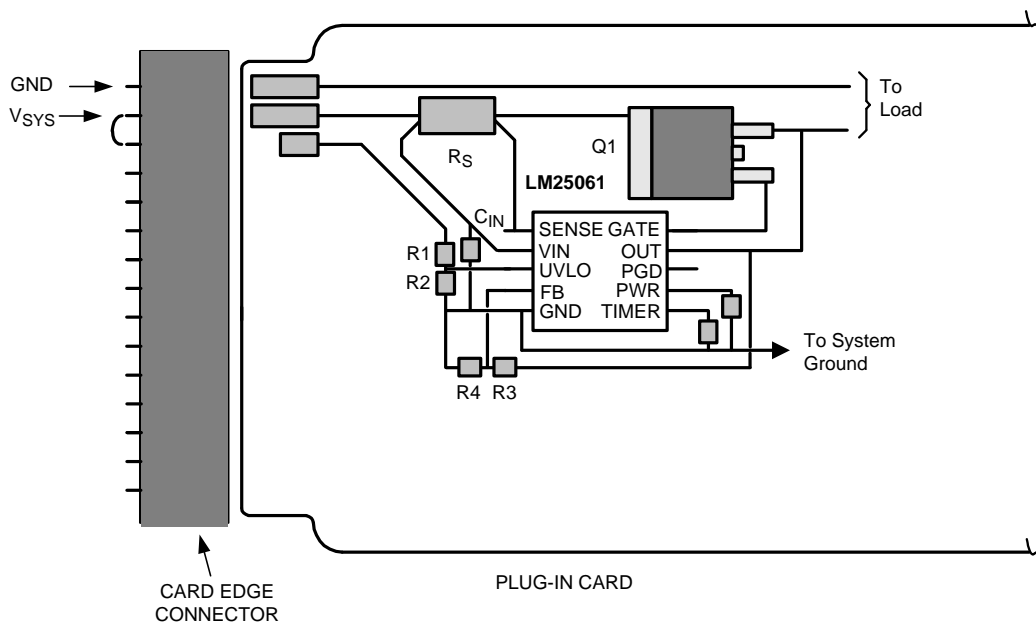

Figure 36. Recommended Board Connector Design

## System Considerations

- Continued proper operation of the LM25061 hot swap circuit requires capacitance be present on the supply side of the connector into which the hot swap circuit is plugged in, as depicted in [Figure 22](#). The capacitor in the “Live Power Source” section is necessary to absorb the transient generated whenever the hot swap circuit shuts off the load current. If the capacitance is not present, inductance in the supply lines will generate a voltage transient at shut-off which can exceed the absolute maximum rating of the LM25061, resulting in its destruction.
- If the load powered by the LM25061 hot swap circuit has inductive characteristics, a Schottky diode is required across the LM25061’s output, along with some load capacitance. The capacitance and the diode are necessary to limit the negative excursion at the OUT pin when the load current is shut off. If the OUT pin transitions more than 0.3V negative the LM25061 will internally reset, interfering with the latch-off feature of the LM25061-1, or the restart cycle of the LM25061-2. See [Figure 37](#).

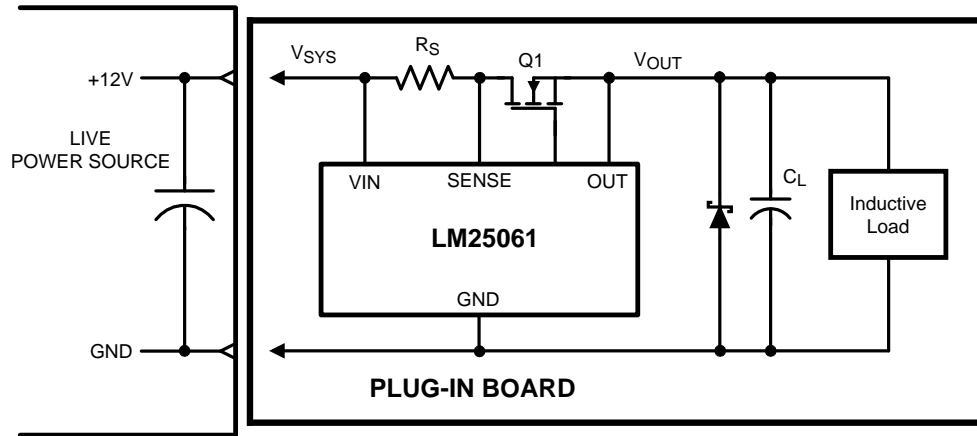

Figure 37. Output Diode Required for Inductive Loads

---

**REVISION HISTORY**

<b>Changes from Revision D (March 2013) to Revision E</b>	<b>Page</b>
<hr/> <ul style="list-style-type: none"><li>• Changed layout of National Data Sheet to TI format .....</li></ul>	<hr/> <a href="#">22</a>

## PACKAGING INFORMATION

Orderable Device	Status (1)	Package Type	Package Drawing	Pins	Package Qty	Eco Plan (2)	Lead/Ball Finish (6)	MSL Peak Temp (3)	Op Temp (°C)	Device Marking (4/5)	Samples
LM25061PMM-1/NOPB	ACTIVE	VSSOP	DGS	10	1000	Green (RoHS & no Sb/Br)	SN	Level-1-260C-UNLIM	-40 to 85	SXSB	<a href="#">Samples</a>
LM25061PMM-2/NOPB	ACTIVE	VSSOP	DGS	10	1000	Green (RoHS & no Sb/Br)	SN	Level-1-260C-UNLIM	-40 to 85	SXRB	<a href="#">Samples</a>
LM25061PMME-1/NOPB	ACTIVE	VSSOP	DGS	10	250	Green (RoHS & no Sb/Br)	SN	Level-1-260C-UNLIM	-40 to 85	SXSB	<a href="#">Samples</a>
LM25061PMME-2/NOPB	ACTIVE	VSSOP	DGS	10	250	Green (RoHS & no Sb/Br)	SN	Level-1-260C-UNLIM	-40 to 85	SXRB	<a href="#">Samples</a>
LM25061PMMX-1/NOPB	ACTIVE	VSSOP	DGS	10	3500	Green (RoHS & no Sb/Br)	SN	Level-1-260C-UNLIM	-40 to 85	SXSB	<a href="#">Samples</a>
LM25061PMMX-2/NOPB	ACTIVE	VSSOP	DGS	10	3500	Green (RoHS & no Sb/Br)	SN	Level-1-260C-UNLIM	-40 to 85	SXRB	<a href="#">Samples</a>

(1) The marketing status values are defined as follows:

**ACTIVE:** Product device recommended for new designs.

**LIFEBUY:** TI has announced that the device will be discontinued, and a lifetime-buy period is in effect.

**NRND:** Not recommended for new designs. Device is in production to support existing customers, but TI does not recommend using this part in a new design.

**PREVIEW:** Device has been announced but is not in production. Samples may or may not be available.

**OBSOLETE:** TI has discontinued the production of the device.

(2) **RoHS:** TI defines "RoHS" to mean semiconductor products that are compliant with the current EU RoHS requirements for all 10 RoHS substances, including the requirement that RoHS substance do not exceed 0.1% by weight in homogeneous materials. Where designed to be soldered at high temperatures, "RoHS" products are suitable for use in specified lead-free processes. TI may reference these types of products as "Pb-Free".

**RoHS Exempt:** TI defines "RoHS Exempt" to mean products that contain lead but are compliant with EU RoHS pursuant to a specific EU RoHS exemption.

**Green:** TI defines "Green" to mean the content of Chlorine (Cl) and Bromine (Br) based flame retardants meet JS709B low halogen requirements of <=1000ppm threshold. Antimony trioxide based flame retardants must also meet the <=1000ppm threshold requirement.

(3) MSL, Peak Temp. - The Moisture Sensitivity Level rating according to the JEDEC industry standard classifications, and peak solder temperature.

(4) There may be additional marking, which relates to the logo, the lot trace code information, or the environmental category on the device.

(5) Multiple Device Markings will be inside parentheses. Only one Device Marking contained in parentheses and separated by a "~" will appear on a device. If a line is indented then it is a continuation of the previous line and the two combined represent the entire Device Marking for that device.



<sup>(6)</sup> Lead/Ball Finish - Orderable Devices may have multiple material finish options. Finish options are separated by a vertical ruled line. Lead/Ball Finish values may wrap to two lines if the finish value exceeds the maximum column width.

**Important Information and Disclaimer:**The information provided on this page represents TI's knowledge and belief as of the date that it is provided. TI bases its knowledge and belief on information provided by third parties, and makes no representation or warranty as to the accuracy of such information. Efforts are underway to better integrate information from third parties. TI has taken and continues to take reasonable steps to provide representative and accurate information but may not have conducted destructive testing or chemical analysis on incoming materials and chemicals. TI and TI suppliers consider certain information to be proprietary, and thus CAS numbers and other limited information may not be available for release.

In no event shall TI's liability arising out of such information exceed the total purchase price of the TI part(s) at issue in this document sold by TI to Customer on an annual basis.

**TAPE AND REEL INFORMATION**

**QUADRANT ASSIGNMENTS FOR PIN 1 ORIENTATION IN TAPE**

\*All dimensions are nominal

Device	Package Type	Package Drawing	Pins	SPQ	Reel Diameter (mm)	Reel Width W1 (mm)	A0 (mm)	B0 (mm)	K0 (mm)	P1 (mm)	W (mm)	Pin1 Quadrant
LM25061PMM-1/NOPB	VSSOP	DGS	10	1000	178.0	12.4	5.3	3.4	1.4	8.0	12.0	Q1
LM25061PMM-2/NOPB	VSSOP	DGS	10	1000	178.0	12.4	5.3	3.4	1.4	8.0	12.0	Q1
LM25061PMME-1/NOPB	VSSOP	DGS	10	250	178.0	12.4	5.3	3.4	1.4	8.0	12.0	Q1
LM25061PMME-2/NOPB	VSSOP	DGS	10	250	178.0	12.4	5.3	3.4	1.4	8.0	12.0	Q1
LM25061PMMX-1/NOPB	VSSOP	DGS	10	3500	330.0	12.4	5.3	3.4	1.4	8.0	12.0	Q1
LM25061PMMX-2/NOPB	VSSOP	DGS	10	3500	330.0	12.4	5.3	3.4	1.4	8.0	12.0	Q1

**TAPE AND REEL BOX DIMENSIONS**

\*All dimensions are nominal

Device	Package Type	Package Drawing	Pins	SPQ	Length (mm)	Width (mm)	Height (mm)
LM25061PMM-1/NOPB	VSSOP	DGS	10	1000	210.0	185.0	35.0
LM25061PMM-2/NOPB	VSSOP	DGS	10	1000	210.0	185.0	35.0
LM25061PMME-1/NOPB	VSSOP	DGS	10	250	210.0	185.0	35.0
LM25061PMME-2/NOPB	VSSOP	DGS	10	250	210.0	185.0	35.0
LM25061PMMX-1/NOPB	VSSOP	DGS	10	3500	367.0	367.0	35.0
LM25061PMMX-2/NOPB	VSSOP	DGS	10	3500	367.0	367.0	35.0

# DGS0010A



# PACKAGE OUTLINE

## VSSOP - 1.1 mm max height

SMALL OUTLINE PACKAGE



### NOTES:

1. All linear dimensions are in millimeters. Any dimensions in parenthesis are for reference only. Dimensioning and tolerancing per ASME Y14.5M.
2. This drawing is subject to change without notice.
3. This dimension does not include mold flash, protrusions, or gate burrs. Mold flash, protrusions, or gate burrs shall not exceed 0.15 mm per side.
4. This dimension does not include interlead flash. Interlead flash shall not exceed 0.25 mm per side.
5. Reference JEDEC registration MO-187, variation BA.

# EXAMPLE BOARD LAYOUT

DGS0010A

VSSOP - 1.1 mm max height

SMALL OUTLINE PACKAGE



LAND PATTERN EXAMPLE  
SCALE:10X



SOLDER MASK DETAILS  
NOT TO SCALE

4221984/A 05/2015

NOTES: (continued)

- 6. Publication IPC-7351 may have alternate designs.
- 7. Solder mask tolerances between and around signal pads can vary based on board fabrication site.

# EXAMPLE STENCIL DESIGN

DGS0010A

VSSOP - 1.1 mm max height

SMALL OUTLINE PACKAGE



SOLDER PASTE EXAMPLE  
BASED ON 0.125 mm THICK STENCIL  
SCALE:10X

4221984/A 05/2015

NOTES: (continued)

8. Laser cutting apertures with trapezoidal walls and rounded corners may offer better paste release. IPC-7525 may have alternate design recommendations.
9. Board assembly site may have different recommendations for stencil design.

## IMPORTANT NOTICE AND DISCLAIMER

TI PROVIDES TECHNICAL AND RELIABILITY DATA (INCLUDING DATASHEETS), DESIGN RESOURCES (INCLUDING REFERENCE DESIGNS), APPLICATION OR OTHER DESIGN ADVICE, WEB TOOLS, SAFETY INFORMATION, AND OTHER RESOURCES "AS IS" AND WITH ALL FAULTS, AND DISCLAIMS ALL WARRANTIES, EXPRESS AND IMPLIED, INCLUDING WITHOUT LIMITATION ANY IMPLIED WARRANTIES OF MERCHANTABILITY, FITNESS FOR A PARTICULAR PURPOSE OR NON-INFRINGEMENT OF THIRD PARTY INTELLECTUAL PROPERTY RIGHTS.

These resources are intended for skilled developers designing with TI products. You are solely responsible for (1) selecting the appropriate TI products for your application, (2) designing, validating and testing your application, and (3) ensuring your application meets applicable standards, and any other safety, security, or other requirements. These resources are subject to change without notice. TI grants you permission to use these resources only for development of an application that uses the TI products described in the resource. Other reproduction and display of these resources is prohibited. No license is granted to any other TI intellectual property right or to any third party intellectual property right. TI disclaims responsibility for, and you will fully indemnify TI and its representatives against, any claims, damages, costs, losses, and liabilities arising out of your use of these resources.

TI's products are provided subject to TI's Terms of Sale ([www.ti.com/legal/termsofsale.html](http://www.ti.com/legal/termsofsale.html)) or other applicable terms available either on [ti.com](http://ti.com) or provided in conjunction with such TI products. TI's provision of these resources does not expand or otherwise alter TI's applicable warranties or warranty disclaimers for TI products.

Mailing Address: Texas Instruments, Post Office Box 655303, Dallas, Texas 75265  
Copyright © 2020, Texas Instruments Incorporated