

# LMK61PDEV

## User's Guide



Literature Number: SNAU193A  
November 2015—Revised November 2015

## LMK61PDEV User's Guide

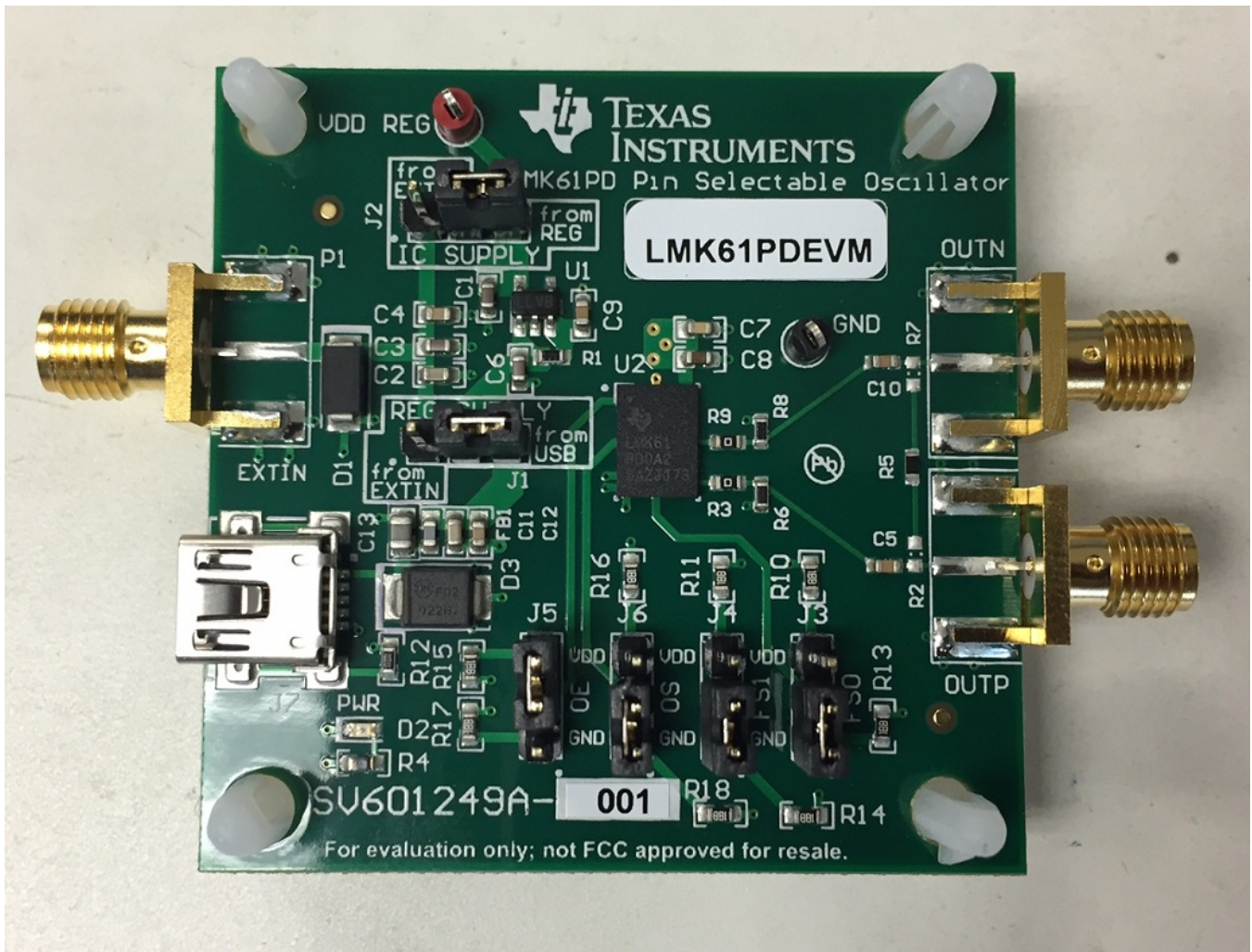

Figure 1. LMK61PDEV Photo

Table 1. Ordering Information

EVM ID	DEVICE ID	DEVICE PACKAGE
LMK61PDEV (SV601249A-001)	LMK61PD0A2-SIA	5 mm x 7 mm 8-pin QFM (SIA)

## 1 Overview

The LMK61PDEV evaluation module provides a complete evaluation platform to evaluate the clock performance and flexibility of the Texas Instruments LMK61PD0A2 Ultra-Low Jitter Crystal Oscillator, with seven unique selectable reference clock frequencies, pin configurable differential output format (LVPECL, LVDS, or HCSL), and integrated LDOs.

The LMK61PDEV can be used as a flexible clock source for compliance testing, performance evaluation, and initial system prototyping. The onboard edge-launch SMA ports provides access to the LMK61PD0A2's configurable clock output for interfacing to test equipment and reference boards using commercially available coaxial cables, adapters, or baluns (not included). This connectivity enables integrated system level testing between TI's LMK61PD0A2 and third-party FPGA/ASIC/SoC reference boards.

## 2 Features

- Pin Selectable Output Frequency
  - 62.5 MHz, 100 MHz, 106.25 MHz, 125 MHz, 156.25 MHz, 212.5 MHz, or 312.5 MHz
- Pin Selectable Output Format
  - LVPECL, LVDS, or HCSL
- External Power supply inputs or powered over USB
- LED indicators: Device Power
- Configurable output format termination to support LVPECL, LVDS, or HCSL

### 3 EVM Configuration

The LMK61PD0A2 is a highly-configurable crystal oscillator with simple power supply requirements and flexible clock output formats. To support a wide range of evaluation use cases, the EVM was designed for maximum flexibility so various configurations options that are not required in all typical system applications have been included.

This section describes the jumpers and connectors on the EVM, as well as how to connect, set-up, and use the LMK61PDEV. When operating the LMK61PDEV, the power supply and clock outputs can be connected to the SMA ports shown in Figure 2. Additionally, the USB port can be used to power the entire LMK61PDEV without the need for external power supplies. These SMA ports are labeled in the top silkscreen layer.

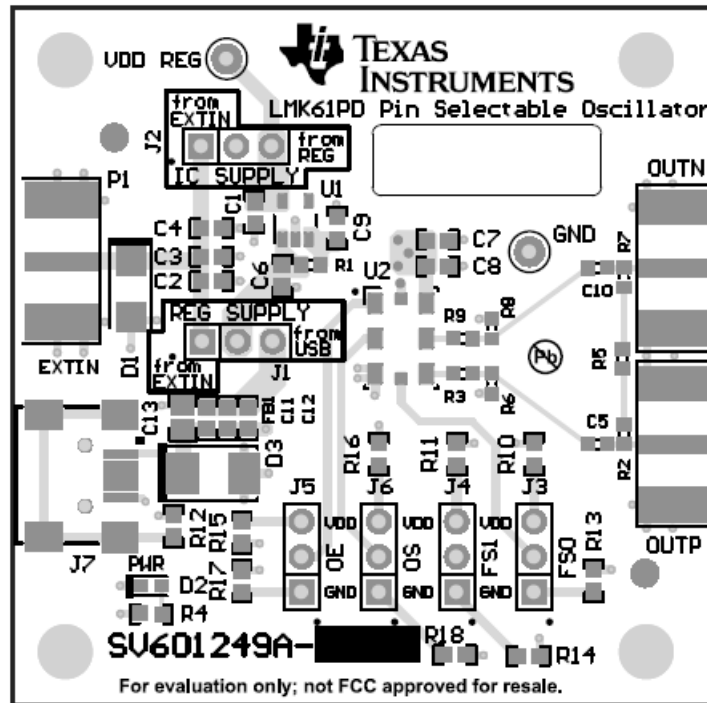

Figure 2. LMK61PDEV Board Layout

### 3.1 Configuring the Power Supply

The LMK61PD0A2 features a single VDD supply pin that operates from 3.3V (+ 5%). This supply can be powered directly on the EVM from an external supply or through an on-board LDO regulator. Although the LMK61PD0A2 has integrated LDO regulators for excellent power-supply-ripple-rejection (PSRR), the EVM's on-board regulator (U1) can allow a higher supply voltage (up to 5.5 V) to power the EVM. The direct external supply or on-board regulator can be independently routed for the VDD supply pin by configuring the power terminals and jumpers shown in Figure 3. J7 (USB mini connector) is the default power supply for the EVM, featuring a low noise regulator for voltage step down. Power SMA Port EXTIN (P1) provides an alternative connector style to apply power using coax cables. Using EXTIN while connected to USB power is not required but can be useful when testing with externally regulated supplies.

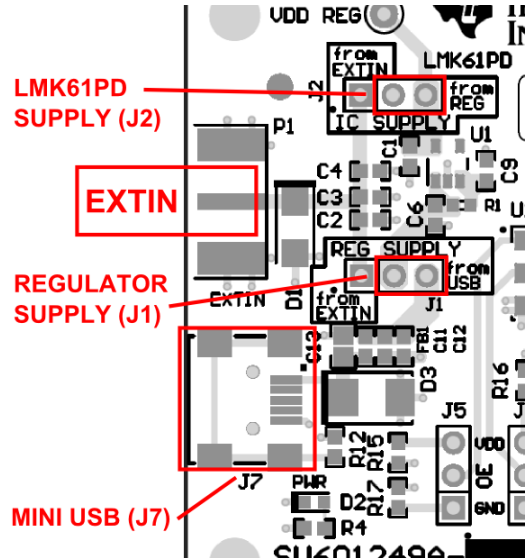

Figure 3. Power Terminals and Jumpers

Table 2 summarizes the EVM power configurations to connect and route power to the onboard LDOs and LMK61PD0A2. Refer to the EVM schematic for more details.

Table 2. Power Configurations

MODE	EXTIN VOLTAGE	J1 SETTING <sup>(1)</sup>	J2 SETTING <sup>(1)</sup>
USB Powered <sup>(2)</sup>		from USB	from REG
External Power + LDO	4.3 V to 5.5 V	from EXTIN	
External Power	3.3 V	Remove Jumper	from EXTIN

<sup>(1)</sup> Markings surrounding J1 or J2 indicate the orientation of jumper settings

<sup>(2)</sup> USB cable must be connected to J7 for operation

**NOTE:** Power delivery over the USB interface is subject to limitations of specific USB ports. Certain systems may require the use of an external supplied power source for proper operation.

### 3.2 Configuring the Control Pins

The LMK61PD0A2 has several control pins dedicated for control of output format, output frequency, and output enable control. These control pins can be configured through the jumpers shown in [Table 3](#).

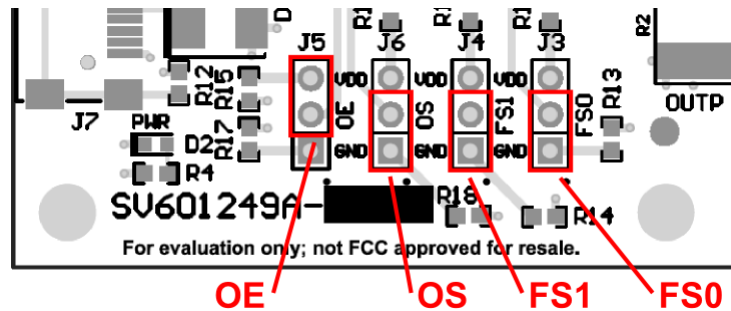

**Figure 4. Control Pin Interfaces (Default jumper settings shown)**

Jumpers J3, J4, J5, and J6 can be used to configure the corresponding control pin to either high or low state by strapping the center pin to “VDD” position (tie pins 2-3) or “GND” position (tie pins 1-2), respectively. Connections from the “VDD” position to the device supply or from the “GND” position to the ground plane are connected by 1.5 kΩ resistors.

The LMK61PD0A2 control pins serve several functions unique to device pins. For a description of each pin’s functionality and the device configuration based on their power up state, refer to [Table 3](#).

**Table 3. Control Pin Interfaces**

COMPONENT	NAME	DESCRIPTION																														
J3 / J4	FS0 / FS1	<b>Output Frequency Select</b>																														
		The state of FS[1:0] controls the device output frequency.																														
		<table border="1"> <thead> <tr> <th>FS1</th> <th>FS0</th> <th>OPERATING MODE</th> </tr> </thead> <tbody> <tr> <td>0</td> <td>0</td> <td>100 MHz</td> </tr> <tr> <td>0</td> <td>NC</td> <td>312.5 MHz</td> </tr> <tr> <td>0</td> <td>1</td> <td>125 MHz</td> </tr> <tr> <td>NC</td> <td>0</td> <td>106.25 MHz</td> </tr> <tr> <td>NC</td> <td>NC</td> <td>156.25 MHz</td> </tr> <tr> <td>NC</td> <td>1</td> <td>212.5 MHz</td> </tr> <tr> <td>1</td> <td>0</td> <td>62.5 MHz</td> </tr> <tr> <td>1</td> <td>NC</td> <td>Reserved</td> </tr> <tr> <td>1</td> <td>1</td> <td>Reserved</td> </tr> </tbody> </table>	FS1	FS0	OPERATING MODE	0	0	100 MHz	0	NC	312.5 MHz	0	1	125 MHz	NC	0	106.25 MHz	NC	NC	156.25 MHz	NC	1	212.5 MHz	1	0	62.5 MHz	1	NC	Reserved	1	1	Reserved
		FS1	FS0	OPERATING MODE																												
		0	0	100 MHz																												
		0	NC	312.5 MHz																												
		0	1	125 MHz																												
		NC	0	106.25 MHz																												
		NC	NC	156.25 MHz																												
		NC	1	212.5 MHz																												
1	0	62.5 MHz																														
1	NC	Reserved																														
1	1	Reserved																														
J5	OE	<b>Output Enable</b>																														
		The state of OE controls device output enable or disable.																														
		<table border="1"> <thead> <tr> <th>OE</th> <th>Output Status</th> </tr> </thead> <tbody> <tr> <td>0</td> <td>Output Disabled (PLL functional)</td> </tr> <tr> <td>1</td> <td>Output Enabled</td> </tr> </tbody> </table>	OE	Output Status	0	Output Disabled (PLL functional)	1	Output Enabled																								
		OE	Output Status																													
0	Output Disabled (PLL functional)																															
1	Output Enabled																															
J6	OS	<b>Output Type Select</b>																														
		The state of OS controls device output format.																														
		<table border="1"> <thead> <tr> <th>OS</th> <th>Output Format</th> </tr> </thead> <tbody> <tr> <td>0</td> <td>LVPECL</td> </tr> <tr> <td>NC</td> <td>LVDS</td> </tr> <tr> <td>1</td> <td>HCSL</td> </tr> </tbody> </table>	OS	Output Format	0	LVPECL	NC	LVDS	1	HCSL																						
		OS	Output Format																													
		0	LVPECL																													
NC	LVDS																															
1	HCSL																															

### 3.3 Configuring the Clock Output

The LMK61PD0A2's differential output is routed via 50 ohm single ended traces to SMA ports (OUTN and OUTP) through AC coupling capacitors. The output also has a series resistor (0 ohm populated by default, R3 and R9) and emitter resistors (150 ohm populated by default for LVPECL, R6 and R8). Common output format terminations are shown in Table 4. The output termination schematic is shown in Figure 5.

Table 4. Output Termination Schemes

OUTPUT FORMAT	COUPLING	COMPONENT	VALUE
LVPECL	AC (default EVM configuration)	R3, R9	0 Ω
		R6, R8	150 Ω
		C5, C10	0.01 μF
		R2, R7, R5	DNP
	DC <sup>(1)</sup>	R3, R9, C5, C10	0 Ω
		R6, R2, R8, R7, R5	DNP
LVDS <sup>(2)</sup>	AC	R3, R2, R9, R7	0 Ω
		R5	100 Ω
		C5, C10	0.01 μF
		R6, R8	DNP
	DC	R3, R2, R9, R7, C5, C10	0 Ω
		R5	100 Ω
HCSL	AC	R3, R9	0 Ω
		R6, R8	50 Ω
		C5, C10	0 Ω
		R2, R7, R5	DNP
	DC	R3, R9	0 Ω
		R6, R8	50 Ω
		C5, C10	0.01 μF
		R2, R7, R5	DNP

<sup>(1)</sup> 50 ohm to Vcc-2 V termination is required on receiver.

<sup>(2)</sup> 100 ohm differential termination (R5) is provided on the LMK61PDEV. Removing the differential termination on the EVM is possible if the differential termination is available on the receiver.

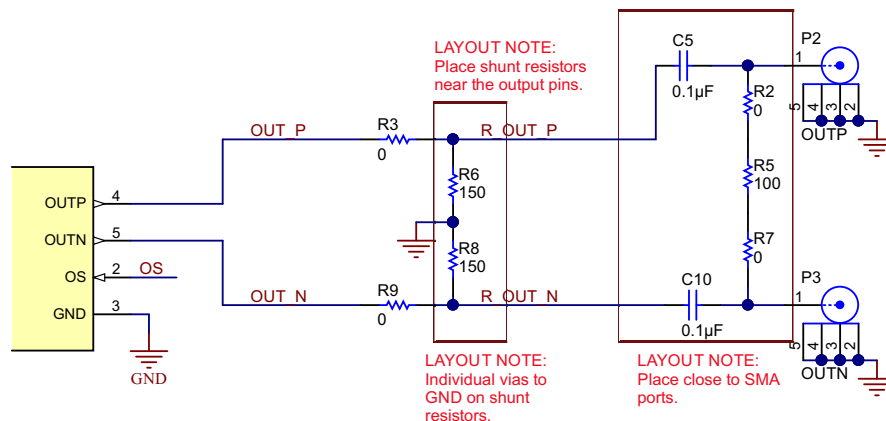

Figure 5. LMK61PDEV Termination Schematic

## 4 EVM Quick Start Guide

The following guide allows the user to quickly configure the LMK61PDEV to evaluate performance and device flexibility.

1. Set the Output Frequency Select Pins (FS0 and FS1) to the desired output frequency as noted in [Table 3](#).
2. Set OS such that the output format selected matches that configured on the EVM. If the desired output format requires reconfiguring the EVM, reference [Table 4](#) for suggested settings.
3. Confirm the EVM Default power configuration is set per [Table 2](#) to power the LMK61PDEV in USB Powered mode using the on-board LDO and power supplied over USB.
  - (a) Reference [Section 3.1](#) for other possible EVM power configurations.
4. Observe any active output clock on OUTN and OUTP SMA ports.
  - (a) Default EVM configuration is AC coupled LVPECL as noted in [Table 4](#).
  - (b) Use 50  $\Omega$  coax cables to connect the test equipment to the output SMA ports. If making a single-ended measurement, terminate the unused SMA port with a 50  $\Omega$  load.
  - (c) Power LED D2 should be illuminated when the EVM is powered on.
5. If a change in Output Frequency is desired, fully power down the EVM, and begin from Step 1.

## 5 Recommended Test Instruments

For making accurate measurements on ultra-low noise/jitter, high-speed clock signals, the following instruments are recommended:

- Source Signal Analyzer: Keysight/Agilent E5052 for phase noise/jitter measurements
- Oscilloscope: Agilent DSA90000A series (or equivalent) for AC measurements and time-domain jitter analysis with jitter software package
- Balun: M/A-COM H-183-4 (30-3000 MHz) 180° coupler, or equivalent

## 6 Example Performance Measurements

RMS Jitter and phase noise measurements were taken on the differential output clock was measured using a balun to a Keysight/Agilent E5052B. Some phase noise plots are provided below.

**Table 5. Typical Output RMS Jitter Summary<sup>(1)(2)</sup>**

Parameter	Test Conditions	RMS Jitter (fs),12k-20M band, spurs off	MIN	TYP	MAX	Unit
RJ	RMS Phase Jitter <sup>(3)</sup> (12 kHz - 20 MHz) (1 kHz - 5 MHz)	$f_{OUT} \geq 100$ MHz		100	200	fs RMS
RJ	RMS Phase Jitter <sup>(3)</sup> (12 kHz - 20 MHz) (1 kHz - 5 MHz)	$f_{OUT} = 62.5$ MHz		200	400	fs RMS

<sup>(1)</sup> Phase Jitter measured with Agilent E5052 signal source analyzer using differential to single ended converter (buffer or balun.)

<sup>(2)</sup> All measurements are AC coupled with recommended board terminations as in [Table 4](#).

<sup>(3)</sup> Ensured by characterization.

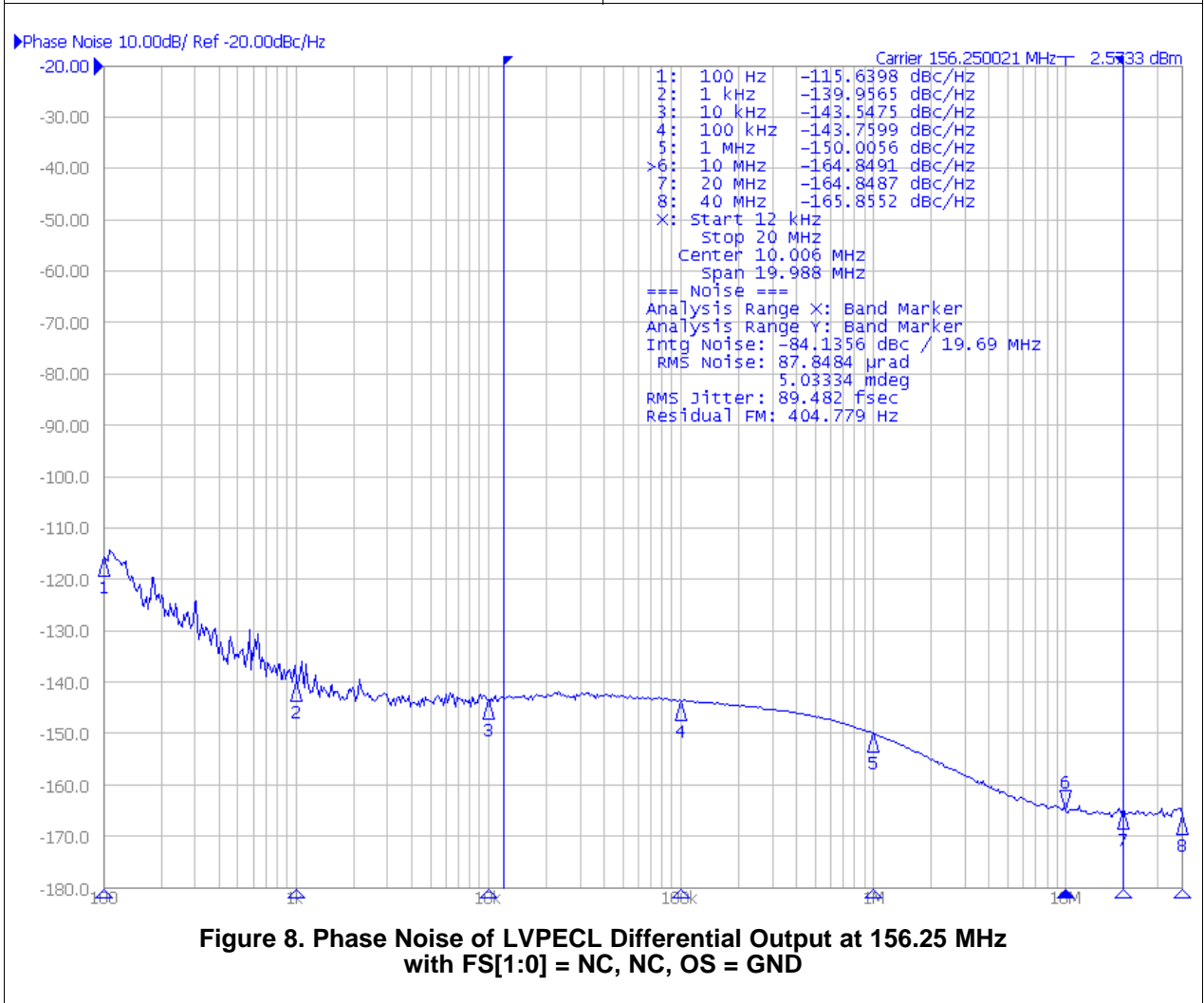
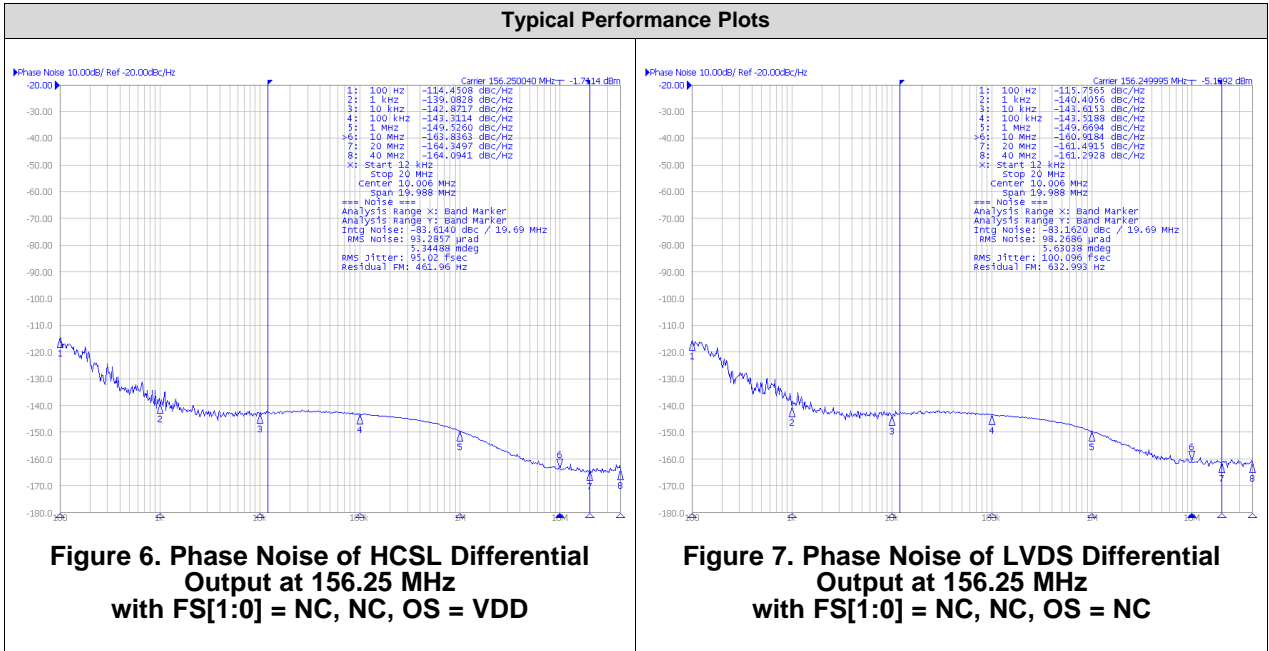

7 EVM Design

7.1 EVM Layout

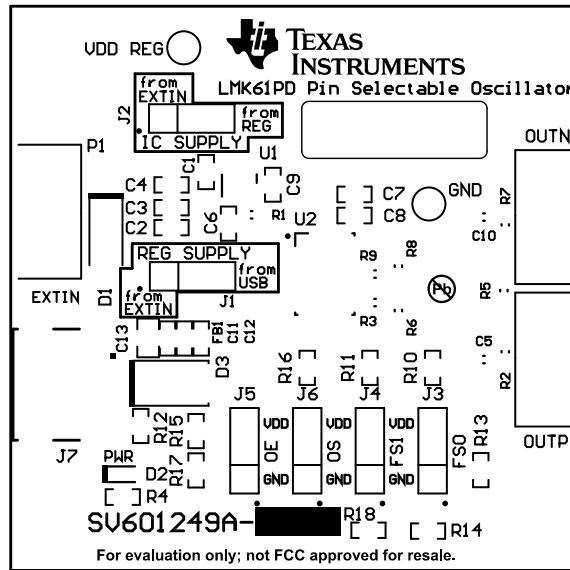

Figure 9. Top Overlay

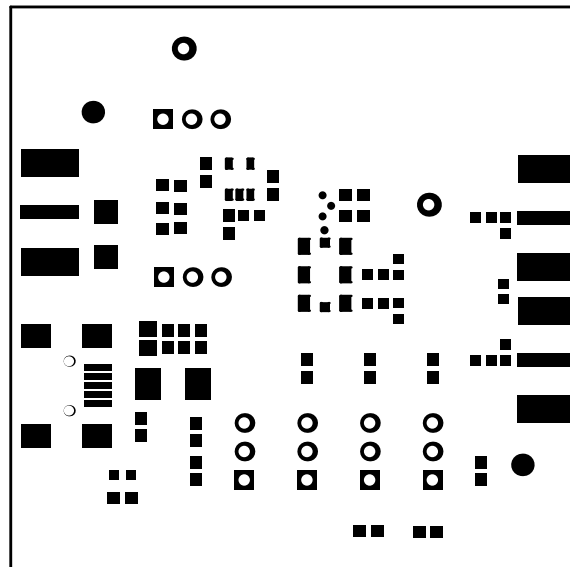

Figure 10. Top Solder Mask

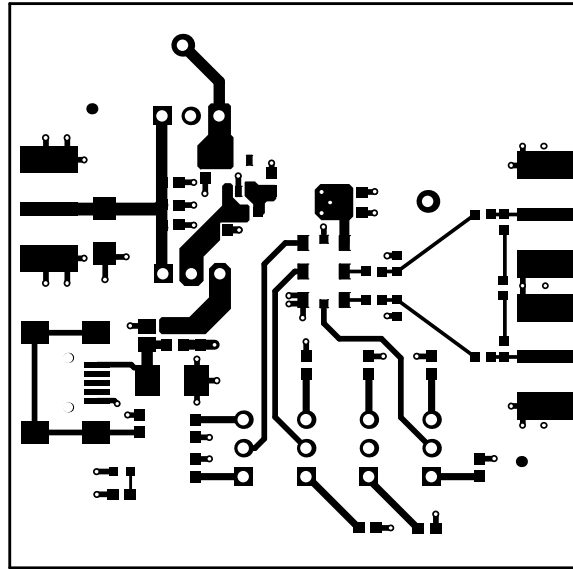

Figure 11. Layer 1 (Top Side)

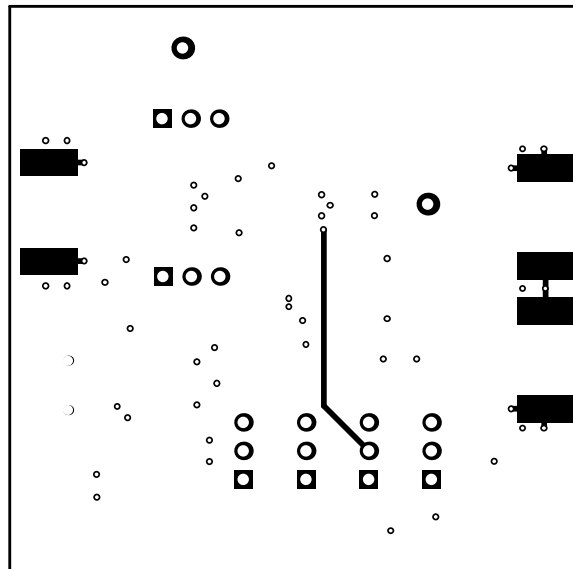
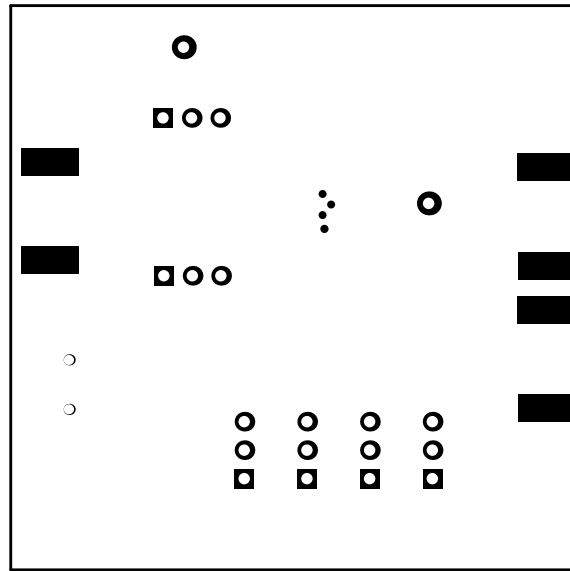
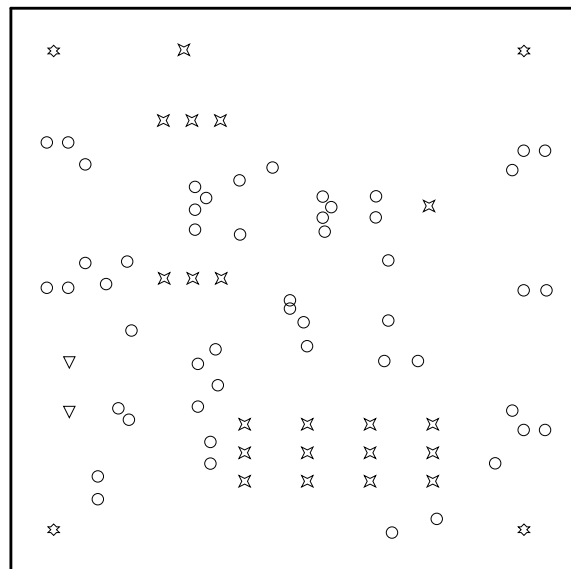

Figure 12. Layer 4 (Bottom Side, View From Bottom)

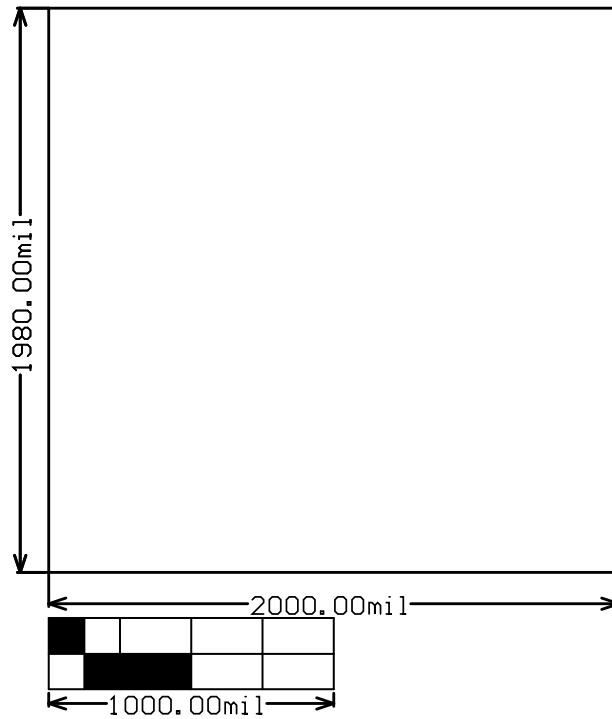

**Figure 13. Bottom Solder Mask**



Symbol	Hit Count	Tool Size	Plated	Hole Type
○	51	13mil (0.33mm)	PTH	Round
▽	2	35.433mil (0.9mm)	NPTH	Round
⊠	20	40mil (1.016mm)	PTH	Round
☆	4	157mil (3.988mm)	NPTH	Round
	77 Total			

**Figure 14. Drill Drawing**



**Figure 15. Board Dimensions**

## 7.2 EVM Schematic

### DIMENSIONS:

- Rectangular shape with height minimized (SMA spacing + board stand offs)
- Final PCB thickness 62 mil +/- 10% \*\*\*\*

### STACKUP:

- Layer 1: Device layer, Power/GPIO Jumper/Switches, RF microstrip from DUT to SMA, USB connector, Silkscreens + Labeling
- ==== FR4: 8 mil
- Layer 2: Ground Plane
- ==== FR4: 38 mil
- Layer 3: Split Power planes for USB circuitry and DUT circuitry
- ==== FR4: 8
- Layer 4: USB circuitry

### Controlled Impedance Traces

- TOP: 13 mil traces to be 50 ohm  $Z_0$  +/- 5% reference to L2

### HARDWARE AND MARKINGS

**LAYOUT NOTE:**  
Place 4 standoffs at corners of board.



H1  
TCBS-6-01



H2  
TCBS-6-01



H3  
TCBS-6-01



H4  
TCBS-6-01



FID1



FID2

**PCB LOGO**  
Pb-Free Symbol

**PCB LOGO**  
FCC disclaimer

**PCB LOGO**  
Texas Instruments

**Label Table**

Variant	Label Text
001	LMK61PDEV

PCB Number: SV601249  
PCB Rev: A

### ASSEMBLY NOTES

**ZZ1**  
**Label Assembly Note**  
This Assembly Note is for PCB labels only

**ZZ2**  
**Assembly Note**  
These assemblies are ESD sensitive, ESD precautions shall be observed.

**ZZ3**  
**Assembly Note**  
These assemblies must be clean and free from flux and all contaminants. Use of no clean flux is not acceptable.

**ZZ4**  
**Assembly Note**  
These assemblies must comply with workmanship standards IPC-A-610 Class 2, unless otherwise specified.

**ZZ5**  
**Assembly Note**  
Default Shunt settings: SH1\_2\_3 means short Pins 2-3 of J1 jumper.

**ZZ6**  
**Assembly Note**  
Default Shunt settings: SH2\_2\_3 means short Pins 2-3 of J2 jumper.

**ZZ7**  
**Assembly Note**  
Default Shunt settings: SH3\_1\_2 means short Pins 1-2 of J3 jumper.

**ZZ8**  
**Assembly Note**  
Default Shunt settings: SH4\_1\_2 means short Pins 1-2 of J4 jumper.

**ZZ9**  
**Assembly Note**  
Default Shunt settings: SH5\_2\_3 means short Pins 2-3 of J5 jumper.

**ZZ10**  
**Assembly Note**  
Default Shunt settings: SH6\_1\_2 means short Pins 1-2 of J6 jumper.

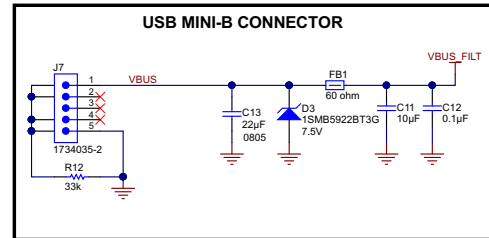
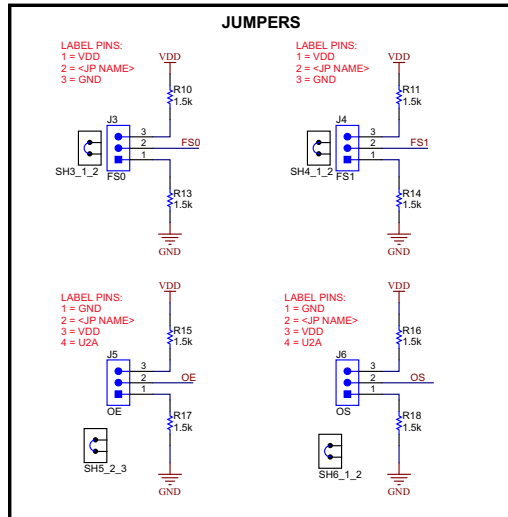
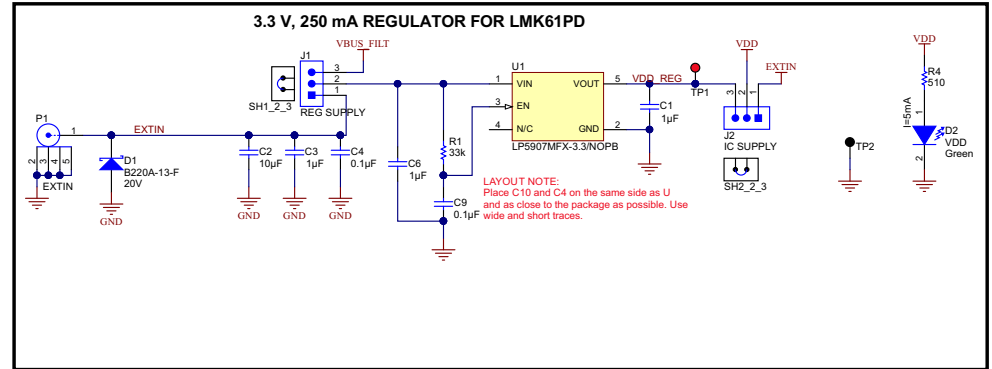
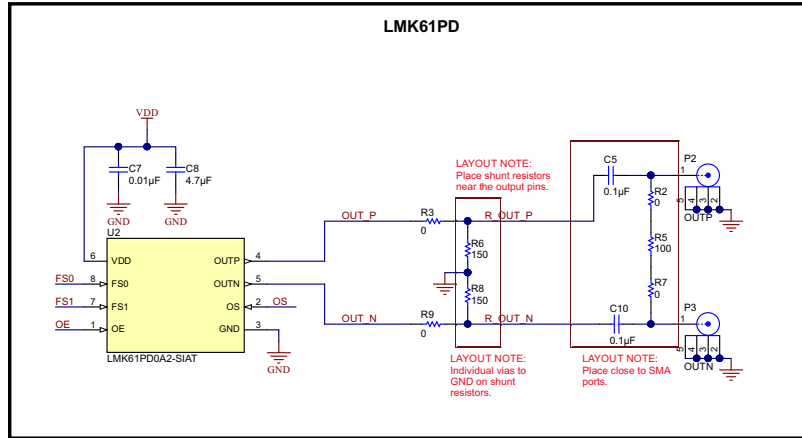

### 7.3 EVM Bill of Materials

DESIGNATOR	DESCRIPTION	MFR	PART NUMBER	QTY
C1, C3, C6	CAP, CERM, 1uF, 10V, +/-10%, X5R, 0603	Kemet	C0603C105K8PACTU	3
C2, C11	CAP, CERM, 10uF, 10V, +/-20%, X5R, 0603	TDK	C1608X5R1A106M	2
C4, C5, C9, C10, C12	CAP, CERM, 0.1uF, 16V, +/-5%, X7R, 0603	Kemet	C0603C104J4RACTU	5
C7	CAP, CERM, 0.01 $\mu$ F, 100 V, +/-5%, X7R, 0603	AVX	06031C103JAT2A	1
C8	CAP, CERM, 4.7 $\mu$ F, 10 V, +/-10%, X5R, 0603	Kemet	C0603C475K8PACTU	1
C13	CAP, CERM, 22uF, 10V, +/-20%, X5R, 0805	Taiyo Yuden	LMK212BJ226MG-T	1
D1	Diode, Schottky, 20V, 2A, SMA	Diodes Inc.	B220A-13-F	1
D2	LED, Green, SMD	Lite-On	LTST-C190GKT	1
D3	Diode, Zener, 7.5V, 550mW, SMB	ON Semiconductor	1SMB5922BT3G	1
FB1	Ferrite Bead, 60 ohm @ 100 MHz, 3.5 A, 0603	TDK	MPZ1608S600A	1
H1, H2, H3, H4	HEX STANDOFF SPACER, 9.53 mm	Richco Plastics	TCBS-6-01	4
J1, J2, J3, J4, J5, J6	Header, 100mil, 3x1, Gold, TH	Samtec	TSW-103-07-G-S	6
J7	Connector, Receptacle, Mini-USB Type B, R/A, Top Mount SMT	TE Connectivity	1734035-2	1
P1, P2, P3	Connector, End launch SMA, 50 ohm, SMT	Emerson Network Power	142-0701-851	3
PCB1	Printed Circuit Board	Any	SV601249	1
R1, R12	RES, 33k ohm, 5%, 0.1W, 0603	Vishay-Dale	CRCW060333K0JNEA	2
R3, R9	RES, 0 ohm, 5%, 0.1W, 0603	Vishay-Dale	CRCW06030000Z0EA	2
R4	RES, 510, 5%, 0.1 W, 0603	Vishay-Dale	CRCW0603510RJNEA	1
R5	RES, 100, 1%, 0.1 W, 0603	Vishay-Dale	CRCW0603100RFKEA	1
R6, R8	RES, 150, 5%, 0.1 W, 0603	Vishay-Dale	CRCW0603150RJNEA	2
R10, R11, R13, R14, R15, R16, R17, R18	RES, 1.5k ohm, 5%, 0.1W, 0603	Vishay-Dale	CRCW06031K50JNEA	8
SH1_2_3, SH2_2_3, SH3_1_2, SH4_1_2, SH5_2_3, SH6_1_2	Shunt, 100mil, Gold plated, Black	3M	969102-0000-DA	6
TP1	Test Point, Miniature, Red, TH	Keystone	5000	1
TP2	GND	Keystone	5001	1
U1	ULTRA LOW-NOISE, 250-mA LINEAR REGULATOR FOR RF AND ANALOG CIRCUITS REQUIRES NO BYPASS CAPACITOR, DBV0005A	Texas Instruments	LP5907MFX-3.3/NOPB	1
U2	Ultra-Low Jitter Pin Programmable Oscillator, SIA0008B	Texas Instruments	LMK61PD0A2-SIAT	1
R2, R7	RES, 0 ohm, 5%, 0.1W, 0603	Vishay-Dale	CRCW06030000Z0EA	0

---

## Revision History

### Changes from Original (November 2015) to A Revision

**Page**

- 
- Production Data release..... [3](#)
- 

NOTE: Page numbers for previous revisions may differ from page numbers in the current version.

## STANDARD TERMS AND CONDITIONS FOR EVALUATION MODULES

1. *Delivery:* TI delivers TI evaluation boards, kits, or modules, including any accompanying demonstration software, components, or documentation (collectively, an "EVM" or "EVMs") to the User ("User") in accordance with the terms and conditions set forth herein. Acceptance of the EVM is expressly subject to the following terms and conditions.
  - 1.1 EVMs are intended solely for product or software developers for use in a research and development setting to facilitate feasibility evaluation, experimentation, or scientific analysis of TI semiconductors products. EVMs have no direct function and are not finished products. EVMs shall not be directly or indirectly assembled as a part or subassembly in any finished product. For clarification, any software or software tools provided with the EVM ("Software") shall not be subject to the terms and conditions set forth herein but rather shall be subject to the applicable terms and conditions that accompany such Software
  - 1.2 EVMs are not intended for consumer or household use. EVMs may not be sold, sublicensed, leased, rented, loaned, assigned, or otherwise distributed for commercial purposes by Users, in whole or in part, or used in any finished product or production system.
2. *Limited Warranty and Related Remedies/Disclaimers:*
  - 2.1 These terms and conditions do not apply to Software. The warranty, if any, for Software is covered in the applicable Software License Agreement.
  - 2.2 TI warrants that the TI EVM will conform to TI's published specifications for ninety (90) days after the date TI delivers such EVM to User. Notwithstanding the foregoing, TI shall not be liable for any defects that are caused by neglect, misuse or mistreatment by an entity other than TI, including improper installation or testing, or for any EVMs that have been altered or modified in any way by an entity other than TI. Moreover, TI shall not be liable for any defects that result from User's design, specifications or instructions for such EVMs. Testing and other quality control techniques are used to the extent TI deems necessary or as mandated by government requirements. TI does not test all parameters of each EVM.
  - 2.3 If any EVM fails to conform to the warranty set forth above, TI's sole liability shall be at its option to repair or replace such EVM, or credit User's account for such EVM. TI's liability under this warranty shall be limited to EVMs that are returned during the warranty period to the address designated by TI and that are determined by TI not to conform to such warranty. If TI elects to repair or replace such EVM, TI shall have a reasonable time to repair such EVM or provide replacements. Repaired EVMs shall be warranted for the remainder of the original warranty period. Replaced EVMs shall be warranted for a new full ninety (90) day warranty period.
3. *Regulatory Notices:*
  - 3.1 *United States*
    - 3.1.1 *Notice applicable to EVMs not FCC-Approved:*

This kit is designed to allow product developers to evaluate electronic components, circuitry, or software associated with the kit to determine whether to incorporate such items in a finished product and software developers to write software applications for use with the end product. This kit is not a finished product and when assembled may not be resold or otherwise marketed unless all required FCC equipment authorizations are first obtained. Operation is subject to the condition that this product not cause harmful interference to licensed radio stations and that this product accept harmful interference. Unless the assembled kit is designed to operate under part 15, part 18 or part 95 of this chapter, the operator of the kit must operate under the authority of an FCC license holder or must secure an experimental authorization under part 5 of this chapter.
    - 3.1.2 *For EVMs annotated as FCC – FEDERAL COMMUNICATIONS COMMISSION Part 15 Compliant:*

### CAUTION

This device complies with part 15 of the FCC Rules. Operation is subject to the following two conditions: (1) This device may not cause harmful interference, and (2) this device must accept any interference received, including interference that may cause undesired operation.

Changes or modifications not expressly approved by the party responsible for compliance could void the user's authority to operate the equipment.

### FCC Interference Statement for Class A EVM devices

*NOTE: This equipment has been tested and found to comply with the limits for a Class A digital device, pursuant to part 15 of the FCC Rules. These limits are designed to provide reasonable protection against harmful interference when the equipment is operated in a commercial environment. This equipment generates, uses, and can radiate radio frequency energy and, if not installed and used in accordance with the instruction manual, may cause harmful interference to radio communications. Operation of this equipment in a residential area is likely to cause harmful interference in which case the user will be required to correct the interference at his own expense.*

## **FCC Interference Statement for Class B EVM devices**

*NOTE: This equipment has been tested and found to comply with the limits for a Class B digital device, pursuant to part 15 of the FCC Rules. These limits are designed to provide reasonable protection against harmful interference in a residential installation. This equipment generates, uses and can radiate radio frequency energy and, if not installed and used in accordance with the instructions, may cause harmful interference to radio communications. However, there is no guarantee that interference will not occur in a particular installation. If this equipment does cause harmful interference to radio or television reception, which can be determined by turning the equipment off and on, the user is encouraged to try to correct the interference by one or more of the following measures:*

- Reorient or relocate the receiving antenna.
- Increase the separation between the equipment and receiver.
- Connect the equipment into an outlet on a circuit different from that to which the receiver is connected.
- Consult the dealer or an experienced radio/TV technician for help.

### 3.2 Canada

3.2.1 For EVMs issued with an Industry Canada Certificate of Conformance to RSS-210

#### **Concerning EVMs Including Radio Transmitters:**

This device complies with Industry Canada license-exempt RSS standard(s). Operation is subject to the following two conditions: (1) this device may not cause interference, and (2) this device must accept any interference, including interference that may cause undesired operation of the device.

#### **Concernant les EVMs avec appareils radio:**

Le présent appareil est conforme aux CNR d'Industrie Canada applicables aux appareils radio exempts de licence. L'exploitation est autorisée aux deux conditions suivantes: (1) l'appareil ne doit pas produire de brouillage, et (2) l'utilisateur de l'appareil doit accepter tout brouillage radioélectrique subi, même si le brouillage est susceptible d'en compromettre le fonctionnement.

#### **Concerning EVMs Including Detachable Antennas:**

Under Industry Canada regulations, this radio transmitter may only operate using an antenna of a type and maximum (or lesser) gain approved for the transmitter by Industry Canada. To reduce potential radio interference to other users, the antenna type and its gain should be so chosen that the equivalent isotropically radiated power (e.i.r.p.) is not more than that necessary for successful communication. This radio transmitter has been approved by Industry Canada to operate with the antenna types listed in the user guide with the maximum permissible gain and required antenna impedance for each antenna type indicated. Antenna types not included in this list, having a gain greater than the maximum gain indicated for that type, are strictly prohibited for use with this device.

#### **Concernant les EVMs avec antennes détachables**

Conformément à la réglementation d'Industrie Canada, le présent émetteur radio peut fonctionner avec une antenne d'un type et d'un gain maximal (ou inférieur) approuvé pour l'émetteur par Industrie Canada. Dans le but de réduire les risques de brouillage radioélectrique à l'intention des autres utilisateurs, il faut choisir le type d'antenne et son gain de sorte que la puissance isotrope rayonnée équivalente (p.i.r.e.) ne dépasse pas l'intensité nécessaire à l'établissement d'une communication satisfaisante. Le présent émetteur radio a été approuvé par Industrie Canada pour fonctionner avec les types d'antenne énumérés dans le manuel d'usage et ayant un gain admissible maximal et l'impédance requise pour chaque type d'antenne. Les types d'antenne non inclus dans cette liste, ou dont le gain est supérieur au gain maximal indiqué, sont strictement interdits pour l'exploitation de l'émetteur.

### 3.3 Japan

3.3.1 *Notice for EVMs delivered in Japan:* Please see [http://www.tij.co.jp/lstds/ti\\_ja/general/eStore/notice\\_01.page](http://www.tij.co.jp/lstds/ti_ja/general/eStore/notice_01.page) 日本国内に輸入される評価用キット、ボードについては、次のところをご覧ください。  
[http://www.tij.co.jp/lstds/ti\\_ja/general/eStore/notice\\_01.page](http://www.tij.co.jp/lstds/ti_ja/general/eStore/notice_01.page)

3.3.2 *Notice for Users of EVMs Considered "Radio Frequency Products" in Japan:* EVMs entering Japan may not be certified by TI as conforming to Technical Regulations of Radio Law of Japan.

If User uses EVMs in Japan, not certified to Technical Regulations of Radio Law of Japan, User is required by Radio Law of Japan to follow the instructions below with respect to EVMs:

1. Use EVMs in a shielded room or any other test facility as defined in the notification #173 issued by Ministry of Internal Affairs and Communications on March 28, 2006, based on Sub-section 1.1 of Article 6 of the Ministry's Rule for Enforcement of Radio Law of Japan,
2. Use EVMs only after User obtains the license of Test Radio Station as provided in Radio Law of Japan with respect to EVMs, or
3. Use of EVMs only after User obtains the Technical Regulations Conformity Certification as provided in Radio Law of Japan with respect to EVMs. Also, do not transfer EVMs, unless User gives the same notice above to the transferee. Please note that if User does not follow the instructions above, User will be subject to penalties of Radio Law of Japan.

【無線電波を送信する製品の開発キットをお使いになる際の注意事項】 開発キットの中には技術基準適合証明を受けていないものがあります。技術適合証明を受けていないものご使用に際しては、電波法遵守のため、以下のいずれかの措置を取っていただく必要がありますのでご注意ください。

1. 電波法施行規則第6条第1項第1号に基づく平成18年3月28日総務省告示第173号で定められた電波暗室等の試験設備でご使用いただく。
2. 実験局の免許を取得後ご使用いただく。
3. 技術基準適合証明を取得後ご使用いただく。

なお、本製品は、上記の「ご使用にあたっての注意」を譲渡先、移転先に通知しない限り、譲渡、移転できないものとします。

上記を遵守頂けない場合は、電波法の罰則が適用される可能性があることをご留意ください。日本テキサス・インスツルメンツ株式会社  
東京都新宿区西新宿 6 丁目 2 4 番 1 号  
西新宿三井ビル

3.3.3 *Notice for EVMs for Power Line Communication:* Please see [http://www.tij.co.jp/llds/ti\\_ja/general/eStore/notice\\_02.page](http://www.tij.co.jp/llds/ti_ja/general/eStore/notice_02.page)  
電力線搬送波通信についての開発キットをお使いになる際の注意事項については、次のところをご覧ください。[http://www.tij.co.jp/llds/ti\\_ja/general/eStore/notice\\_02.page](http://www.tij.co.jp/llds/ti_ja/general/eStore/notice_02.page)

#### 4 *EVM Use Restrictions and Warnings:*

4.1 EVMS ARE NOT FOR USE IN FUNCTIONAL SAFETY AND/OR SAFETY CRITICAL EVALUATIONS, INCLUDING BUT NOT LIMITED TO EVALUATIONS OF LIFE SUPPORT APPLICATIONS.

4.2 User must read and apply the user guide and other available documentation provided by TI regarding the EVM prior to handling or using the EVM, including without limitation any warning or restriction notices. The notices contain important safety information related to, for example, temperatures and voltages.

#### 4.3 *Safety-Related Warnings and Restrictions:*

4.3.1 User shall operate the EVM within TI's recommended specifications and environmental considerations stated in the user guide, other available documentation provided by TI, and any other applicable requirements and employ reasonable and customary safeguards. Exceeding the specified performance ratings and specifications (including but not limited to input and output voltage, current, power, and environmental ranges) for the EVM may cause personal injury or death, or property damage. If there are questions concerning performance ratings and specifications, User should contact a TI field representative prior to connecting interface electronics including input power and intended loads. Any loads applied outside of the specified output range may also result in unintended and/or inaccurate operation and/or possible permanent damage to the EVM and/or interface electronics. Please consult the EVM user guide prior to connecting any load to the EVM output. If there is uncertainty as to the load specification, please contact a TI field representative. During normal operation, even with the inputs and outputs kept within the specified allowable ranges, some circuit components may have elevated case temperatures. These components include but are not limited to linear regulators, switching transistors, pass transistors, current sense resistors, and heat sinks, which can be identified using the information in the associated documentation. When working with the EVM, please be aware that the EVM may become very warm.

4.3.2 EVMs are intended solely for use by technically qualified, professional electronics experts who are familiar with the dangers and application risks associated with handling electrical mechanical components, systems, and subsystems. User assumes all responsibility and liability for proper and safe handling and use of the EVM by User or its employees, affiliates, contractors or designees. User assumes all responsibility and liability to ensure that any interfaces (electronic and/or mechanical) between the EVM and any human body are designed with suitable isolation and means to safely limit accessible leakage currents to minimize the risk of electrical shock hazard. User assumes all responsibility and liability for any improper or unsafe handling or use of the EVM by User or its employees, affiliates, contractors or designees.

4.4 User assumes all responsibility and liability to determine whether the EVM is subject to any applicable international, federal, state, or local laws and regulations related to User's handling and use of the EVM and, if applicable, User assumes all responsibility and liability for compliance in all respects with such laws and regulations. User assumes all responsibility and liability for proper disposal and recycling of the EVM consistent with all applicable international, federal, state, and local requirements.

5. *Accuracy of Information:* To the extent TI provides information on the availability and function of EVMs, TI attempts to be as accurate as possible. However, TI does not warrant the accuracy of EVM descriptions, EVM availability or other information on its websites as accurate, complete, reliable, current, or error-free.

6. *Disclaimers:*
- 6.1 EXCEPT AS SET FORTH ABOVE, EVMS AND ANY WRITTEN DESIGN MATERIALS PROVIDED WITH THE EVM (AND THE DESIGN OF THE EVM ITSELF) ARE PROVIDED "AS IS" AND "WITH ALL FAULTS." TI DISCLAIMS ALL OTHER WARRANTIES, EXPRESS OR IMPLIED, REGARDING SUCH ITEMS, INCLUDING BUT NOT LIMITED TO ANY IMPLIED WARRANTIES OF MERCHANTABILITY OR FITNESS FOR A PARTICULAR PURPOSE OR NON-INFRINGEMENT OF ANY THIRD PARTY PATENTS, COPYRIGHTS, TRADE SECRETS OR OTHER INTELLECTUAL PROPERTY RIGHTS.
- 6.2 EXCEPT FOR THE LIMITED RIGHT TO USE THE EVM SET FORTH HEREIN, NOTHING IN THESE TERMS AND CONDITIONS SHALL BE CONSTRUED AS GRANTING OR CONFERRING ANY RIGHTS BY LICENSE, PATENT, OR ANY OTHER INDUSTRIAL OR INTELLECTUAL PROPERTY RIGHT OF TI, ITS SUPPLIERS/LICENSORS OR ANY OTHER THIRD PARTY, TO USE THE EVM IN ANY FINISHED END-USER OR READY-TO-USE FINAL PRODUCT, OR FOR ANY INVENTION, DISCOVERY OR IMPROVEMENT MADE, CONCEIVED OR ACQUIRED PRIOR TO OR AFTER DELIVERY OF THE EVM.
7. *USER'S INDEMNITY OBLIGATIONS AND REPRESENTATIONS.* USER WILL DEFEND, INDEMNIFY AND HOLD TI, ITS LICENSORS AND THEIR REPRESENTATIVES HARMLESS FROM AND AGAINST ANY AND ALL CLAIMS, DAMAGES, LOSSES, EXPENSES, COSTS AND LIABILITIES (COLLECTIVELY, "CLAIMS") ARISING OUT OF OR IN CONNECTION WITH ANY HANDLING OR USE OF THE EVM THAT IS NOT IN ACCORDANCE WITH THESE TERMS AND CONDITIONS. THIS OBLIGATION SHALL APPLY WHETHER CLAIMS ARISE UNDER STATUTE, REGULATION, OR THE LAW OF TORT, CONTRACT OR ANY OTHER LEGAL THEORY, AND EVEN IF THE EVM FAILS TO PERFORM AS DESCRIBED OR EXPECTED.
8. *Limitations on Damages and Liability:*
- 8.1 *General Limitations.* IN NO EVENT SHALL TI BE LIABLE FOR ANY SPECIAL, COLLATERAL, INDIRECT, PUNITIVE, INCIDENTAL, CONSEQUENTIAL, OR EXEMPLARY DAMAGES IN CONNECTION WITH OR ARISING OUT OF THESE TERMS AND CONDITIONS OR THE USE OF THE EVMS PROVIDED HEREUNDER, REGARDLESS OF WHETHER TI HAS BEEN ADVISED OF THE POSSIBILITY OF SUCH DAMAGES. EXCLUDED DAMAGES INCLUDE, BUT ARE NOT LIMITED TO, COST OF REMOVAL OR REINSTALLATION, ANCILLARY COSTS TO THE PROCUREMENT OF SUBSTITUTE GOODS OR SERVICES, RETESTING, OUTSIDE COMPUTER TIME, LABOR COSTS, LOSS OF GOODWILL, LOSS OF PROFITS, LOSS OF SAVINGS, LOSS OF USE, LOSS OF DATA, OR BUSINESS INTERRUPTION. NO CLAIM, SUIT OR ACTION SHALL BE BROUGHT AGAINST TI MORE THAN ONE YEAR AFTER THE RELATED CAUSE OF ACTION HAS OCCURRED.
- 8.2 *Specific Limitations.* IN NO EVENT SHALL TI'S AGGREGATE LIABILITY FROM ANY WARRANTY OR OTHER OBLIGATION ARISING OUT OF OR IN CONNECTION WITH THESE TERMS AND CONDITIONS, OR ANY USE OF ANY TI EVM PROVIDED HEREUNDER, EXCEED THE TOTAL AMOUNT PAID TO TI FOR THE PARTICULAR UNITS SOLD UNDER THESE TERMS AND CONDITIONS WITH RESPECT TO WHICH LOSSES OR DAMAGES ARE CLAIMED. THE EXISTENCE OF MORE THAN ONE CLAIM AGAINST THE PARTICULAR UNITS SOLD TO USER UNDER THESE TERMS AND CONDITIONS SHALL NOT ENLARGE OR EXTEND THIS LIMIT.
9. *Return Policy.* Except as otherwise provided, TI does not offer any refunds, returns, or exchanges. Furthermore, no return of EVM(s) will be accepted if the package has been opened and no return of the EVM(s) will be accepted if they are damaged or otherwise not in a resalable condition. If User feels it has been incorrectly charged for the EVM(s) it ordered or that delivery violates the applicable order, User should contact TI. All refunds will be made in full within thirty (30) working days from the return of the components(s), excluding any postage or packaging costs.
10. *Governing Law:* These terms and conditions shall be governed by and interpreted in accordance with the laws of the State of Texas, without reference to conflict-of-laws principles. User agrees that non-exclusive jurisdiction for any dispute arising out of or relating to these terms and conditions lies within courts located in the State of Texas and consents to venue in Dallas County, Texas. Notwithstanding the foregoing, any judgment may be enforced in any United States or foreign court, and TI may seek injunctive relief in any United States or foreign court.

Mailing Address: Texas Instruments, Post Office Box 655303, Dallas, Texas 75265  
Copyright © 2015, Texas Instruments Incorporated

## IMPORTANT NOTICE

Texas Instruments Incorporated and its subsidiaries (TI) reserve the right to make corrections, enhancements, improvements and other changes to its semiconductor products and services per JESD46, latest issue, and to discontinue any product or service per JESD48, latest issue. Buyers should obtain the latest relevant information before placing orders and should verify that such information is current and complete. All semiconductor products (also referred to herein as "components") are sold subject to TI's terms and conditions of sale supplied at the time of order acknowledgment.

TI warrants performance of its components to the specifications applicable at the time of sale, in accordance with the warranty in TI's terms and conditions of sale of semiconductor products. Testing and other quality control techniques are used to the extent TI deems necessary to support this warranty. Except where mandated by applicable law, testing of all parameters of each component is not necessarily performed.

TI assumes no liability for applications assistance or the design of Buyers' products. Buyers are responsible for their products and applications using TI components. To minimize the risks associated with Buyers' products and applications, Buyers should provide adequate design and operating safeguards.

TI does not warrant or represent that any license, either express or implied, is granted under any patent right, copyright, mask work right, or other intellectual property right relating to any combination, machine, or process in which TI components or services are used. Information published by TI regarding third-party products or services does not constitute a license to use such products or services or a warranty or endorsement thereof. Use of such information may require a license from a third party under the patents or other intellectual property of the third party, or a license from TI under the patents or other intellectual property of TI.

Reproduction of significant portions of TI information in TI data books or data sheets is permissible only if reproduction is without alteration and is accompanied by all associated warranties, conditions, limitations, and notices. TI is not responsible or liable for such altered documentation. Information of third parties may be subject to additional restrictions.

Resale of TI components or services with statements different from or beyond the parameters stated by TI for that component or service voids all express and any implied warranties for the associated TI component or service and is an unfair and deceptive business practice. TI is not responsible or liable for any such statements.

Buyer acknowledges and agrees that it is solely responsible for compliance with all legal, regulatory and safety-related requirements concerning its products, and any use of TI components in its applications, notwithstanding any applications-related information or support that may be provided by TI. Buyer represents and agrees that it has all the necessary expertise to create and implement safeguards which anticipate dangerous consequences of failures, monitor failures and their consequences, lessen the likelihood of failures that might cause harm and take appropriate remedial actions. Buyer will fully indemnify TI and its representatives against any damages arising out of the use of any TI components in safety-critical applications.

In some cases, TI components may be promoted specifically to facilitate safety-related applications. With such components, TI's goal is to help enable customers to design and create their own end-product solutions that meet applicable functional safety standards and requirements. Nonetheless, such components are subject to these terms.

No TI components are authorized for use in FDA Class III (or similar life-critical medical equipment) unless authorized officers of the parties have executed a special agreement specifically governing such use.

Only those TI components which TI has specifically designated as military grade or "enhanced plastic" are designed and intended for use in military/aerospace applications or environments. Buyer acknowledges and agrees that any military or aerospace use of TI components which have **not** been so designated is solely at the Buyer's risk, and that Buyer is solely responsible for compliance with all legal and regulatory requirements in connection with such use.

TI has specifically designated certain components as meeting ISO/TS16949 requirements, mainly for automotive use. In any case of use of non-designated products, TI will not be responsible for any failure to meet ISO/TS16949.

### Products

Audio	<a href="http://www.ti.com/audio">www.ti.com/audio</a>
Amplifiers	<a href="http://amplifier.ti.com">amplifier.ti.com</a>
Data Converters	<a href="http://dataconverter.ti.com">dataconverter.ti.com</a>
DLP® Products	<a href="http://www.dlp.com">www.dlp.com</a>
DSP	<a href="http://dsp.ti.com">dsp.ti.com</a>
Clocks and Timers	<a href="http://www.ti.com/clocks">www.ti.com/clocks</a>
Interface	<a href="http://interface.ti.com">interface.ti.com</a>
Logic	<a href="http://logic.ti.com">logic.ti.com</a>
Power Mgmt	<a href="http://power.ti.com">power.ti.com</a>
Microcontrollers	<a href="http://microcontroller.ti.com">microcontroller.ti.com</a>
RFID	<a href="http://www.ti-rfid.com">www.ti-rfid.com</a>
OMAP Applications Processors	<a href="http://www.ti.com/omap">www.ti.com/omap</a>
Wireless Connectivity	<a href="http://www.ti.com/wirelessconnectivity">www.ti.com/wirelessconnectivity</a>

### Applications

Automotive and Transportation	<a href="http://www.ti.com/automotive">www.ti.com/automotive</a>
Communications and Telecom	<a href="http://www.ti.com/communications">www.ti.com/communications</a>
Computers and Peripherals	<a href="http://www.ti.com/computers">www.ti.com/computers</a>
Consumer Electronics	<a href="http://www.ti.com/consumer-apps">www.ti.com/consumer-apps</a>
Energy and Lighting	<a href="http://www.ti.com/energy">www.ti.com/energy</a>
Industrial	<a href="http://www.ti.com/industrial">www.ti.com/industrial</a>
Medical	<a href="http://www.ti.com/medical">www.ti.com/medical</a>
Security	<a href="http://www.ti.com/security">www.ti.com/security</a>
Space, Avionics and Defense	<a href="http://www.ti.com/space-avionics-defense">www.ti.com/space-avionics-defense</a>
Video and Imaging	<a href="http://www.ti.com/video">www.ti.com/video</a>

### TI E2E Community

[e2e.ti.com](http://e2e.ti.com)