

NB7NPQ702MEVK, NB7VPQ702MEVK

NB7NPQ702MEVK and NB7VPQ702MEVK Evaluation Board User's Manual



ON Semiconductor®

www.onsemi.com

EVAL BOARD USER'S MANUAL

Introduction

The NB7NPQ702MEVK and the NB7VPQ702MEVK evaluation board were developed with a common PCB layout design to provide a convenient platform to quickly verify the operation of the NB7NPQ702M or the NB7VPQ702M re-drivers in a USB type-C system environment.

This evaluation board manual contains:

- Information on the NB7NPQ702M / NB7VPQ702M Evaluation Board
- Board Schematics
- Bill of Materials

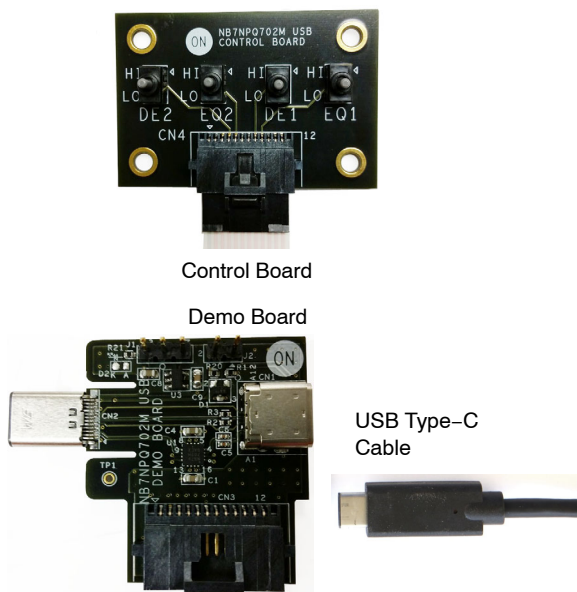

Figure 1. Kit Contents

Board Features

- Accommodates the Functional Evaluation of the NB7NPQ702M and NB7VPQ702M
- Acts as a Reference Design that Can Easily be Modified for Active Cables, UFP (Upstream Facing Port), DFP (Downstream Facing Port), and DRP (Dual Role Port) Applications
- Type-C Plug and Receptacle to Easily Place in the Existing System Environment
- External Control Board to Easily Change Pin Settings without Compromising Form Factor

Part Description

The NB7NPQ702M is a 3.3 V and the NB7VPQ702M is a 1.8 V dual channel re-driver for USB 3.1 applications that support both 5 and 10 Gbps data rates. Signal integrity degrades from PCB traces and transmission cables which may cause inter-symbol interference (ISI). The NB7NPQ702M and NB7VPQ702M compensate for these losses by engaging varying levels of equalization at the input receiver. The output transmitter circuitry provides user selectable de-emphasis and output amplitude settings to create the best eye openings for the outgoing data signals. The flexibility of this part allows it to fit into many system applications.

The NB7NPQ702M / NB7VPQ702M features an intelligent LFPS circuit. This circuit senses the low frequency signals and automatically disables driver de-emphasis for full USB 3.1 compliances.

After power up, the NB7NPQ702M / NB7VPQ702M periodically checks both of the TX output pairs for a SuperSpeed USB receiver. When the receiver is detected, the RX termination becomes enabled and the NB7NPQ702M / NB7VPQ702M is set to perform the re-drive function.

The NB7NPQ702M and NB7VPQ702M come in a 3 mm x 3 mm UQFN-16 package and are specified to operate across the entire industrial temperature range, -40°C to 85°C.

This manual should be used in conjunction with the device datasheet which contains full technical details on the device specifications and operation.

NB7NPQ702MEVK, NB7VPQ702MEVK

BOARD MAP

Figure 2 illustrates the locations of major features and components. The following information will guide you

through the necessary configuration for proper operation.

Vbus / Vconn

This jumper is used to select the voltage source to the LDO

LDO

Regulates the 5V Vbus or Vconn voltage down to 3.3 V or 1.8 V

NB7NPQ702M NB7VPQ702M U1

Control Pin Resistors

Pin strap controls can be fixed by soldering down resistors so that U2 may be controlled without the control board

LDO to VCC

The LDO's 3.3 V or 1.8 V output can be disconnected from the VCC of the re-drivers so that an external power supply or a longer wire for current probes can be soldered to monitor power consumption of the two re-drivers

Isolation Diodes

Two diodes to isolate the Vconn/CC2 lines between the UFP and DFP

USB 2.0 Lines

The 0 Ω resistors on D+ and D- lines can be removed to guarantee USB 3.0 operation only

TX AC Coupling Capacitor

0.1 μF is connected on the TX lines for proper RXDetect sequence

VCC Test Point

This point can be used to monitor the voltage on VCC pins of the re-driver

Ribbon Cable for Control Board

Adjust the LVCMOS pin strap controls (EQ/DE/OS) on both of the re-drivers

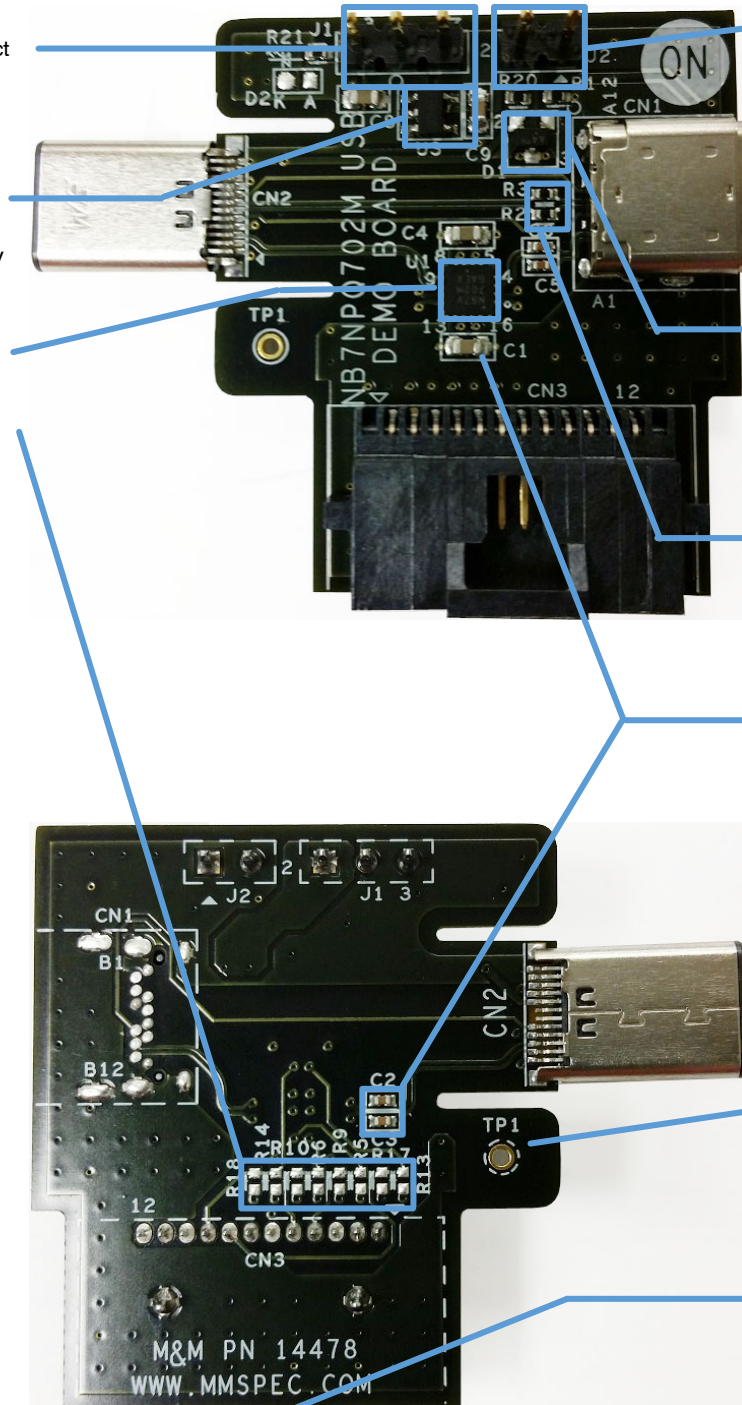
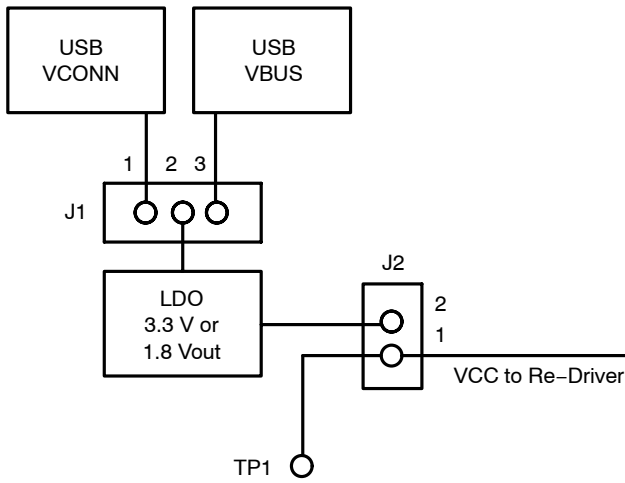

Figure 2. NB7NPQ702M / NB7VPQ702M Evaluation Board Top and Bottom View

NB7NPQ702MEVK, NB7VPQ702MEVK

Step 1: Select Power Source

The NB7NPQ702MEVK / NB7VPQ702MEVK has the flexibility to be powered through USB's VBUS, VCONN, or an external power supply. Table 1 describes the jumper settings for each of the configuration:



Step 1 Select Power Source	
VBUS or VCONN	J2 Short pins 1 and 2
External Supply	Open J2 Connect positive lead of external supply to pin 1 or TP1 and apply 3.3 V or 1.8 V

Step 2 Select VBUS or VCONN	
VBUS	J1 Short pins 2 and 3
VCONN	J1 Short pins 1 and 2

Figure 3. Power Source Selection

Monitoring Current / Power

There are two easy ways to monitor the current consumed by the re-drivers. If you are using an external power supply, you can simply use the current meter commonly found on the equipment. If you would like to use a current probe, simply connect a long wire using clips or solder between pins 1 and 2 on J2. The LED will indicate that there is power to the board.

Step 2: Set DC Control Pins

Both the NB7NPQ702M and NB7VPQ702M re-drivers have de-emphasis and equalization pins that can be independently set. This can be done by soldering a 0 Ω resistor to force a setting on the un-populated pads, or by connecting the demo board to the control board with the ribbon cable and using the 3-position switches. If the pins are left floating (neither resistor is soldered nor is the control board attached) then the parts de-emphasis and equalization will default to the mid-level. **The amount of de-emphasis and equalization will depend on the cable length / material that is added by the user.** With longer the loss material, higher settings will be required. For minimum loss (or no loss), all pins should be set to Low.

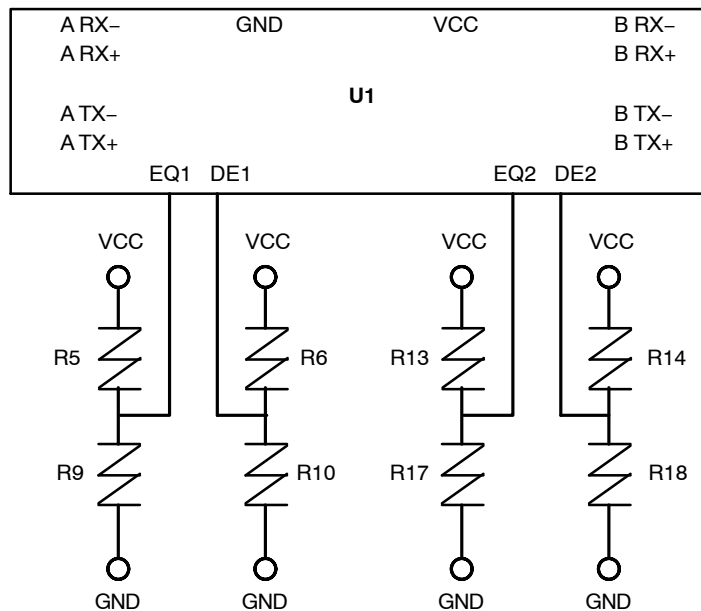

Figure 4. Resistor Pads to Set DC Control Pins

NB7NPQ702MEVK, NB7VPQ702MEVK

Step 3: Connect in the USB Type-C Application

The standard (non-active, non-full featured) cable has a CC pin on the top and bottom side of the plug connector. As

seen in the USB Type-C Spec (rev 1.1) Table 3-6 USB Type-C Standard Cable Wire Assignments, only one CC pin is connected from plug to plug as seen below:

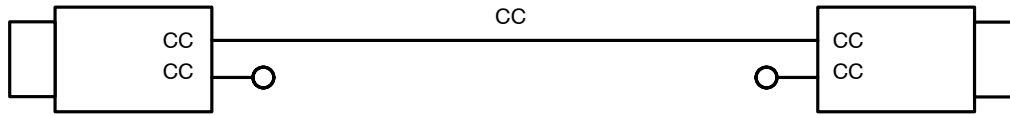

Figure 5. Standard Type-C Cable CC Line

This creates the need for the following two rules for proper operation:

1. If powering from VCONN, EVB must be placed on the DFP side of the cable.
When a USB type-C connection is detected, the CC controllers will determine the orientation by seeing which CC# pin is making a connection between the DFP and UFP. On the DFP side, the other CC# pin will look for the Ra resistor in order to power up VCONN (5V line).
If not followed: If the EVB is placed on the UFP side, due to the break in the 'other' CC line in the cable, the DFP will not be able to detect the Ra resistor. Consequently, VCONN power will not be applied to the CC2 line. Even if VCONN was somehow enabled, the EVB will not see this voltage as there is still a break in the cable.
2. The cable's CC wire must be connected to EVB's CC1 line.
As mentioned in rule 1's explanation, the CC

controllers will determine the orientation by seeing which CC# pin is making a connection between the DFP and the UFP.

If not followed: If the standard type-C cable is plugged in so that the open CC pin is connected to CC1 and the CC wire is connected to VCONN/CC2's isolation diode of the EVB, neither side will establish a connection to the CC# pin. As a result, the PD controllers will not go through the hand-shaking process and it will assume that there are no peripheral devices attached to the host. In most cases, power will be turned off on both VBUS and VCONN.

The flipping function of Type-C connector can be demonstrated between the DFP and the EVB as well as between UFP and the EVB. Since this board emulates an active cable application, the actual implementation would only function in this manner.

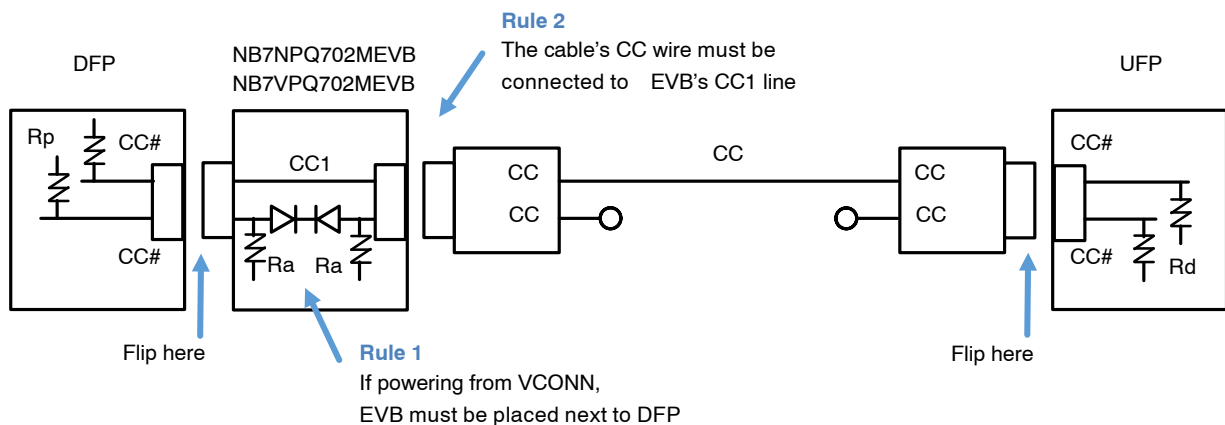

Figure 6. How to Connect the EVB to a Type-C System

Step 4: USB 2.0 Data Lines

The USB 2.0 lines can be disconnected by removing the 0 Ω resistors R2 and R3 on the D+ and D- lines. This is useful if you cannot easily tell whether the DFP has acknowledged a super speed (+) connection with the inserted loss, or if it stepped down to high speed. When a receiver is detected through RxDetect, the DFP will initialize link training. It will send a test signal out at the highest data rate and expect to see the same signal sent back

by the UFP. If the signals do not match due to ISI (or any other connection issues) then it will drop down the data rate to USB 2.0 speed.

On Windows machines, an easy way to tell that a super speed connection was not established is to look for a pop-up in the task bar letting the user know that "This device can perform faster". A disk benchmarking tool like Crystal Disk Mark that lets you test read and write speeds to a peripheral storage can also be used.

NB7NPQ702MEVK, NB7VPQ702MEVK

SCHEMATICS

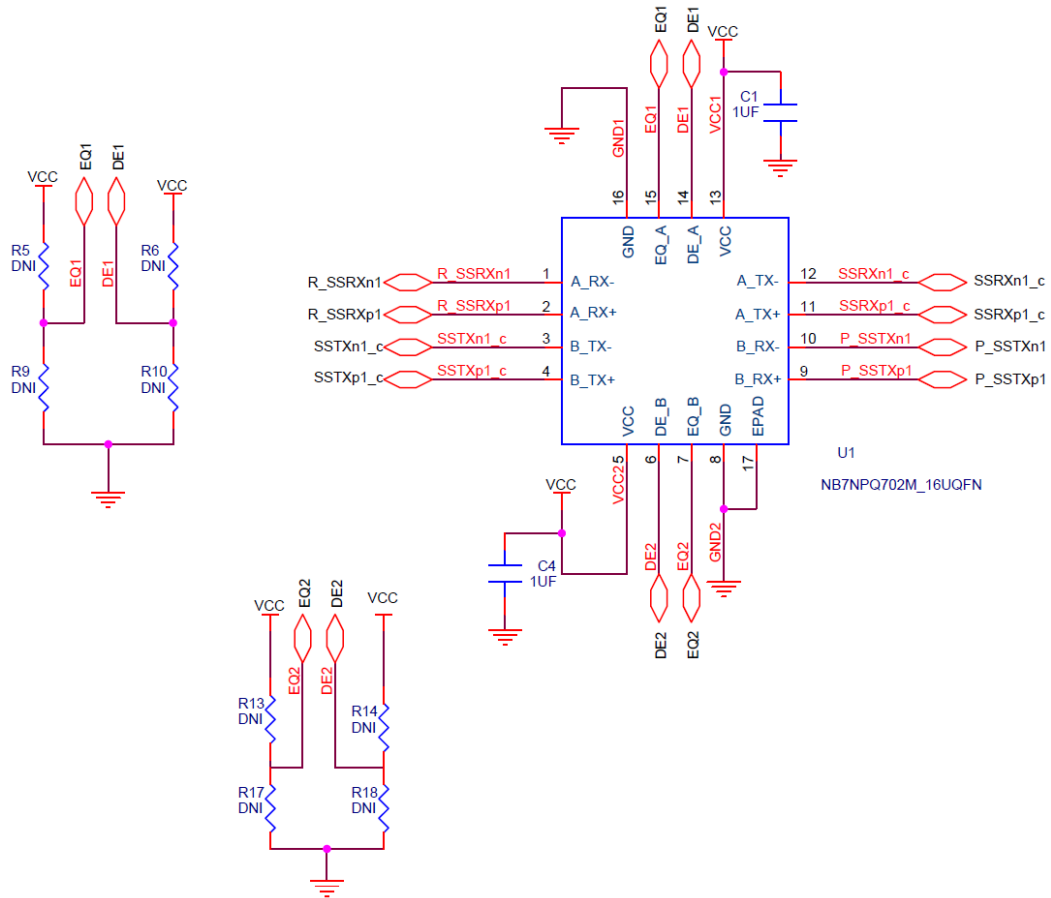

Figure 7. NB7NPQ702MEVK / NB7VPQ702MEVK USB-C Schematic

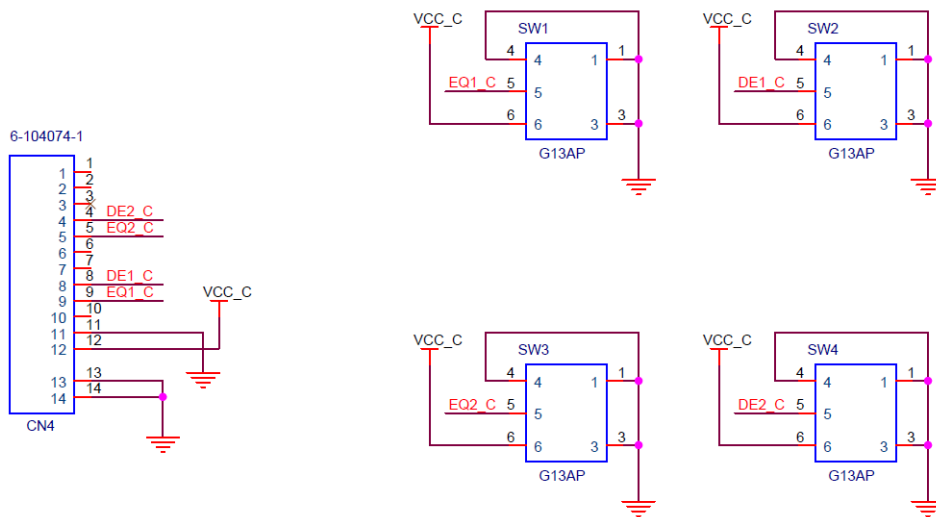

Figure 8. NB7NPQ702MEVK / NB7VPQ702MEVK Control Board Schematic

NB7NPQ702MEVK, NB7VPQ702MEVK

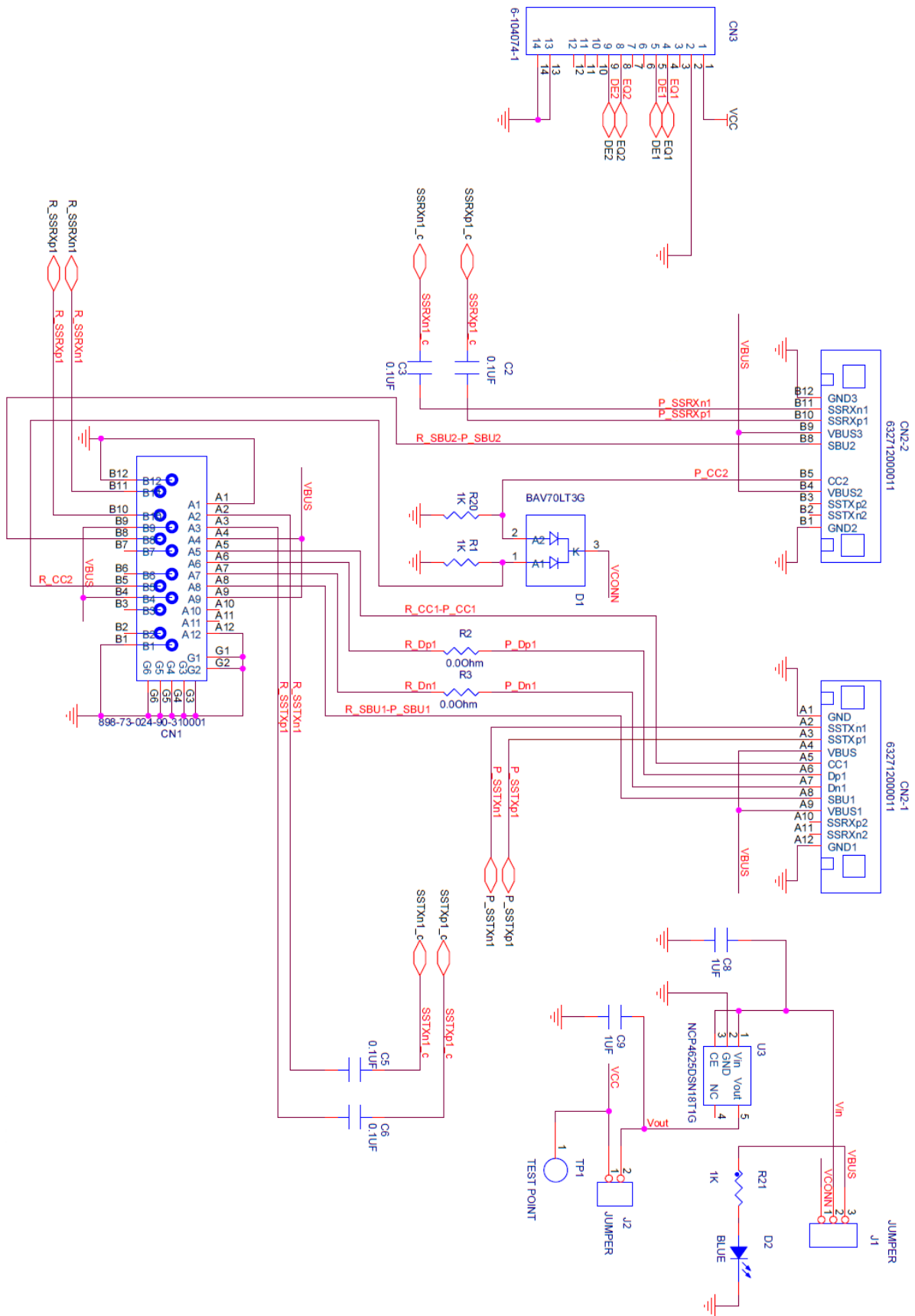
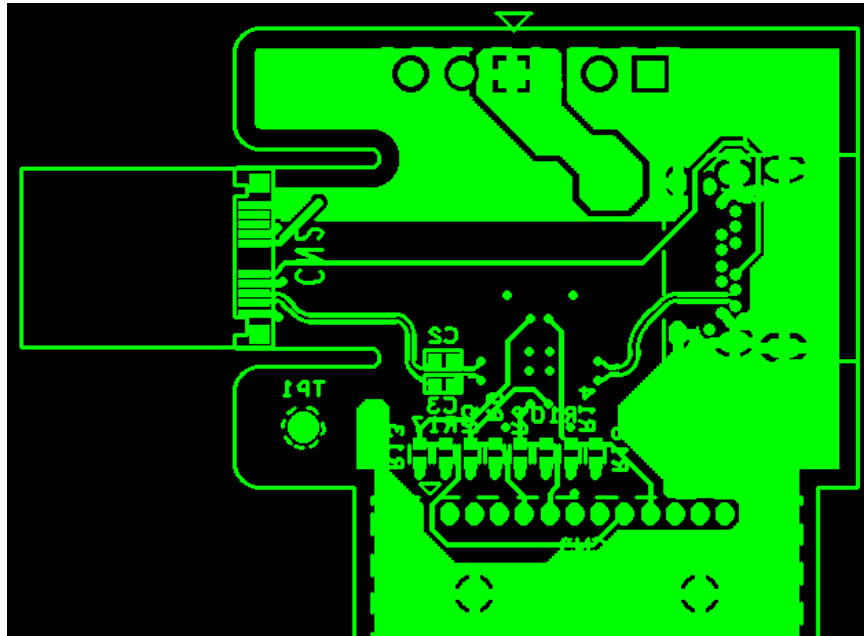

Figure 9. NB7NPQ702MEVK / NB7VPQ702MEVK Type-C Board Schematic

NB7NPQ702MEVK, NB7VPQ702MEVK

BOARD LAYOUT



Top View

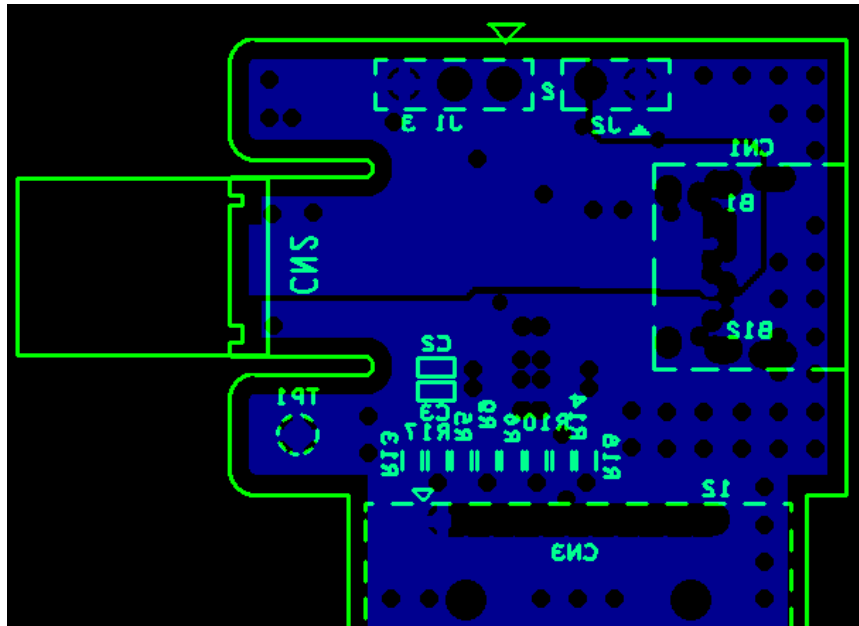

Bottom View

Figure 10. NB7NPQ702MEVK / NB7VPQ702MEVK Evaluation Board Layout

NB7NPQ702MEVK, NB7VPQ702MEVK

BILL OF MATERIALS

Table 1. BILL OF MATERIALS

Quantity	Reference	Description	Value	Manufacturer	Part Number
1	U1	USB 3.1 re-driver, uQFN-16	-	ON Semiconductor	NB7NPQ702M or NB7VPQ702M
1	CN2	USB 3.1 Type-C Plug	-	Würth Elektronik	632 712 000 011
1	CN1	USB 3.1 Type-C Receptacle	-	Mill-Max Manufacturing Corp.	898-73-024-90-310001
1	D1	Dual Diode, Common Cathode	-	ON Semiconductor	BAV70LT3G
4	Control Board Switches	Toggle Switch	-	NKK Switches	G13AP
1	U3	3.3 V Voltage Regulator (NB7NPQ702M) 1.8 V Voltage Regulator (NB7VPQ702M)	-	ON Semiconductor	NCP4625DSN33T1G NCP4625DSN18T1G
2	CN3, CN4	12 Position Right Angle Header	-	TE Connectivity	6-104074-1
1		4" 12 Position Flex Cable	-	TE Connectivity	A9CCA-1204E
1	J1	Header, 0.100"	hdr_1x03_.100	Amphenol FCI	68001-203HLF
1	J2	Header, 0.100"	hdr_1x02_.100	Amphenol FCI	77311-118-02LF
4	C1, C4, C7, C8	0603 Ceramic Cap	1 μ F		
4	C2, C3, C5, C6	0402 Ceramic Cap	0.1 μ F		
3	R1, R20, R21	0402 Resistor	1 K Ω		
2	R2, R3	0402 Resistor	0.0 Ω		
1	D2	LED			

ON Semiconductor and the ON Semiconductor logo are trademarks of Semiconductor Components Industries, LLC dba ON Semiconductor or its subsidiaries in the United States and/or other countries. ON Semiconductor owns the rights to a number of patents, trademarks, copyrights, trade secrets, and other intellectual property. A listing of ON Semiconductor's product/patent coverage may be accessed at www.onsemi.com/site/pdf/Patent-Marking.pdf. ON Semiconductor is an Equal Opportunity/Affirmative Action Employer. This literature is subject to all applicable copyright laws and is not for resale in any manner.

The evaluation board/kit (research and development board/kit) (hereinafter the "board") is not a finished product and is as such not available for sale to consumers. The board is only intended for research, development, demonstration and evaluation purposes and should as such only be used in laboratory/development areas by persons with an engineering/technical training and familiar with the risks associated with handling electrical/mechanical components, systems and subsystems. This person assumes full responsibility/liability for proper and safe handling. Any other use, resale or redistribution for any other purpose is strictly prohibited.

The board is delivered "AS IS" and without warranty of any kind including, but not limited to, that the board is production-worthy, that the functions contained in the board will meet your requirements, or that the operation of the board will be uninterrupted or error free. ON Semiconductor expressly disclaims all warranties, express, implied or otherwise, including without limitation, warranties of fitness for a particular purpose and non-infringement of intellectual property rights.

ON Semiconductor reserves the right to make changes without further notice to any board.

You are responsible for determining whether the board will be suitable for your intended use or application or will achieve your intended results. Prior to using or distributing any systems that have been evaluated, designed or tested using the board, you agree to test and validate your design to confirm the functionality for your application. Any technical, applications or design information or advice, quality characterization, reliability data or other services provided by ON Semiconductor shall not constitute any representation or warranty by ON Semiconductor, and no additional obligations or liabilities shall arise from ON Semiconductor having provided such information or services.

The boards are not designed, intended, or authorized for use in life support systems, or any FDA Class 3 medical devices or medical devices with a similar or equivalent classification in a foreign jurisdiction, or any devices intended for implantation in the human body. Should you purchase or use the board for any such unintended or unauthorized application, you shall indemnify and hold ON Semiconductor and its officers, employees, subsidiaries, affiliates, and distributors harmless against all claims, costs, damages, and expenses, and reasonable attorney fees arising out of, directly or indirectly, any claim of personal injury or death associated with such unintended or unauthorized use, even if such claim alleges that ON Semiconductor was negligent regarding the design or manufacture of the board.

This evaluation board/kit does not fall within the scope of the European Union directives regarding electromagnetic compatibility, restricted substances (RoHS), recycling (WEEE), FCC, CE or UL, and may not meet the technical requirements of these or other related directives.

FCC WARNING – This evaluation board/kit is intended for use for engineering development, demonstration, or evaluation purposes only and is not considered by ON Semiconductor to be a finished end product fit for general consumer use. It may generate, use, or radiate radio frequency energy and has not been tested for compliance with the limits of computing devices pursuant to part 15 of FCC rules, which are designed to provide reasonable protection against radio frequency interference. Operation of this equipment may cause interference with radio communications, in which case the user shall be responsible, at its expense, to take whatever measures may be required to correct this interference.

ON Semiconductor does not convey any license under its patent rights nor the rights of others.

LIMITATIONS OF LIABILITY: ON Semiconductor shall not be liable for any special, consequential, incidental, indirect or punitive damages, including, but not limited to the costs of requalification, delay, loss of profits or goodwill, arising out of or in connection with the board, even if ON Semiconductor is advised of the possibility of such damages. In no event shall ON Semiconductor's aggregate liability from any obligation arising out of or in connection with the board, under any theory of liability, exceed the purchase price paid for the board, if any.

For more information and documentation, please visit www.onsemi.com.

PUBLICATION ORDERING INFORMATION

LITERATURE FULFILLMENT:

Email Requests to: orderlit@onsemi.com

ON Semiconductor Website: www.onsemi.com

TECHNICAL SUPPORT

North American Technical Support:

Voice Mail: 1 800-282-9855 Toll Free USA/Canada

Phone: 011 421 33 790 2910

Europe, Middle East and Africa Technical Support:

Phone: 00421 33 790 2910

For additional information, please contact your local Sales Representative