

ISO774x-Q1 Automotive, High-Speed, Reinforced Quad-Channel Digital Isolators

1 Features

- Qualified for automotive applications
- AEC-Q100 qualified with the following results:
 - Device temperature Grade 1: -40°C to 125°C ambient operating temperature
- 100 Mbps data rate
- Robust isolation barrier:
 - >100 -year projected lifetime at $1500 V_{\text{RMS}}$ working voltage
 - Up to $5700 V_{\text{RMS}}$ isolation rating
 - Up to 12.8 kV surge capability
 - $\pm 100 \text{ kV}/\mu\text{s}$ typical CMTI
- Wide supply range: 2.25 V to 5.5 V
- 2.25-V to 5.5-V level translation
- Default output *high* (ISO774x) and *low* (ISO774xF) options
- Low power consumption, typical 1.5 mA per channel at 1 Mbps
- Low propagation delay: 10.7 ns typical (5-V Supplies)
- Robust electromagnetic compatibility (EMC)
 - System-level ESD, EFT, and surge immunity
 - $\pm 8 \text{ kV}$ IEC 61000-4-2 contact discharge protection across isolation barrier
 - Low emissions
- Extra-wide SOIC (DWW-16), wide-SOIC (DW-16) and QSOP (DBQ-16) package options
- Safety-related certifications:
 - DIN VDE V 0884-11:2017-01
 - UL 1577 component recognition program
 - CSA certification according to IEC 60950-1, IEC 62368-1, IEC 61010-1 and IEC 60601-1 end equipment standards
 - CQC approval per GB4943.1-2011
 - TUV certification according to EN 60950-1, EN 62368-1 and EN 61010-1

2 Applications

- Hybrid, electric and powertrain system (EV/HEV)
 - Battery management system (BMS)
 - On-board charger
 - Traction inverter
 - DC/DC converter
 - Inverter and motor control

3 Description

The ISO774x-Q1 automotive devices are high-performance, quad-channel digital isolators with $5700 V_{\text{RMS}}$ (DWW package), $5000 V_{\text{RMS}}$ (DW package) and $3000 V_{\text{RMS}}$ (DBQ package) isolation ratings per UL 1577. This family of devices has reinforced insulation ratings according to VDE, CSA, TUV and CQC.

Device Information⁽¹⁾

PART NUMBER	PACKAGE	BODY SIZE (NOM)
ISO7741-Q1	SOIC (DWW)	10.30 mm x 14.0 mm
ISO7740-Q1	SOIC (DW)	10.30 mm x 7.50 mm
ISO7741-Q1 ISO7742-Q1	SSOP (DBQ)	4.90 mm x 3.90 mm

(1) For all available packages, see the orderable addendum at the end of the data sheet.

Simplified Schematic

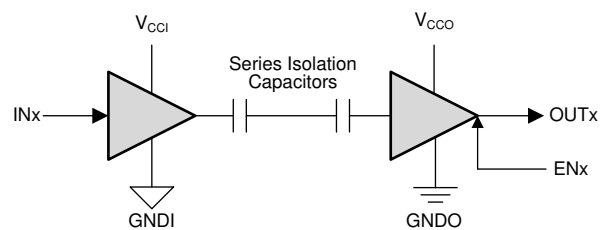

Copyright © 2016, Texas Instruments Incorporated

V_{CCI} =Input supply, V_{CCO} =Output supply
 GNDI =Input ground, GNDO =Output ground



Table of Contents

1 Features	1	7.18 Insulation Characteristics Curves	19
2 Applications	1	7.19 Typical Characteristics	20
3 Description	1	8 Parameter Measurement Information	22
4 Revision History	2	9 Detailed Description	24
5 Description Continued	4	9.1 Overview	24
6 Pin Configuration and Functions	5	9.2 Functional Block Diagram	24
7 Specifications	7	9.3 Feature Description	25
7.1 Absolute Maximum Ratings	7	9.4 Device Functional Modes	26
7.2 ESD Ratings	7	10 Application and Implementation	28
7.3 Recommended Operating Conditions	7	10.1 Application Information	28
7.4 Thermal Information	8	10.2 Typical Application	28
7.5 Power Rating	8	11 Power Supply Recommendations	31
7.6 Insulation Specifications	9	12 Layout	32
7.7 Safety-Related Certifications	10	12.1 Layout Guidelines	32
7.8 Safety Limiting Values	10	12.2 Layout Example	32
7.9 Electrical Characteristics—5-V Supply	11	13 Device and Documentation Support	33
7.10 Supply Current Characteristics—5-V Supply	12	13.1 Documentation Support	33
7.11 Electrical Characteristics—3.3-V Supply	13	13.2 Related Links	33
7.12 Supply Current Characteristics—3.3-V Supply	14	13.3 Receiving Notification of Documentation Updates	33
7.13 Electrical Characteristics—2.5-V Supply	15	13.4 Community Resources	33
7.14 Supply Current Characteristics—2.5-V Supply	16	13.5 Trademarks	33
7.15 Switching Characteristics—5-V Supply	17	13.6 Electrostatic Discharge Caution	33
7.16 Switching Characteristics—3.3-V Supply	17	13.7 Glossary	33
7.17 Switching Characteristics—2.5-V Supply	18	14 Mechanical, Packaging, and Orderable Information	34

4 Revision History

NOTE: Page numbers for previous revisions may differ from page numbers in the current version.

Changes from Revision B (June 2018) to Revision C	Page
• Made editorial and cosmetic changes throughout the document	1
• Changed From: "Isolation Barrier Life: >40 Years" To: ">100-year projected lifetime at 1500 V _{RMS} working voltage" in Features	1
• Added "Up to 5700 V _{RMS} isolation rating" in Features	1
• Added "Up to 12.8 kV surge capability" in Features	1
• Added "±8 kV IEC 61000-4-2 contact discharge protection across isolation barrier" in Features	1
• Changed VDE standard name From: DIN V VDE V 0884-11:2017-01 To: DIN VDE V 0884-11:2017-01 throughout the document	1
• Updated list of applications in Applications section	1
• Updated Simplified Schematic to show two isolation capacitors in series per channel instead of a single isolation capacitor	1
• Added extra-wide SOIC (DWW-16) package information for ISO7741-Q1 in the datasheet	4
• Added "Contact discharge per IEC 61000-4-2" specification of ±8000 V in ESD Ratings	7
• Added the following table note to <i>Data rate</i> specification: "100 Mbps is the maximum specified data rate, although higher data rates are possible."	7
• Changed ISO7741-Q1 P _{D1} or Maximum power dissipation by side-1 From: 50 mW To: 75 mW and P _{D2} or Maximum power dissipation by side-2 From: 150 mW To: 125 mW in Power Rating table	8
• Changed V _{IORM} value for DW-16 package From: "1414 V _{PK} " To: "2121 V _{PK} " in Insulation Specifications table	9
• Changed V _{IOWM} values for DW-16 package From: "1000 V _{RMS} " and "1414 V _{DC} " To: "1500 V _{RMS} " and "2121 V _{DC} " in Insulation Specifications table	9
• Added 'see Figure 30 ' to TEST CONDITIONS of V _{IOWM} specification in Insulation Specifications	9

Revision History (continued)

• Changed V_{IOSM} TEST CONDITIONS From: "Test method per IEC 60065" To: "Test method per IEC 62368-1" in Insulation Specifications table	9
• Updated certification information in Safety-Related Certifications table	10
• Corrected ground symbol for 'Input (ISO774xF)' schematic in Device I/O Schematics	27
• Updated Figure 24 by changing CAN transceiver From: SN65HVD231Q To: TCAN1042-Q1 and transformer driver From: SN6501-Q1 To: SN6505x-Q1	28
• Added Insulation Lifetime sub-section under Application Curve section.....	30
• Added SN6505x-Q1 reference in Power Supply Recommendations section	31
• Added 'How to use isolation to improve ESD, EFT, and Surge immunity in industrial systems' application report to Documentation Support section	33
• Added SN6505x-Q1 data sheet reference in Documentation Support section	33

Changes from Revision A (May 2018) to Revision B
Page

• Changed the isolation rating of the DBQ package from 2500 V_{RMS} to 3000 V_{RMS}	1
• Moved the HBM and CDM values from the <i>Features</i> section to the <i>ESD Ratings</i> table	7
• Added V_{TEST} to the conditions for the maximum transient isolation voltage parameter in the <i>Insulation Specifications</i> table	9
• Changed the value for the DBQ package from 3600 V_{PK} to 4242 V_{PK} throughout the document	9
• Changed the method b1 V_{ini} condition for apparent charge in the <i>Insulation Specifications</i> table	9
• Switched the line colors for V_{CC} at 2.5 V and V_{CC} at 3.3 V in Figure 14	20
• Switched the labels for V_{CC1} falling and V_{CC2} rising in the graph legend of <i>Power Supply Undervoltage Threshold vs Free-Air Temperature</i>	20

Changes from Original (November 2016) to Revision A
Page

• Updated the <i>Safety-Related Certifications</i> table.....	10
• Changed the minimum CMTI from 40 to 85 in all <i>Electrical Characteristics</i> tables	11

5 Description Continued

The ISO774x-Q1 devices provide high electromagnetic immunity and low emissions at low power consumption, while isolating CMOS or LVCMOS digital I/Os. Each isolation channel has a logic input and output buffer separated by a double capacitive silicon dioxide (SiO₂) insulation barrier. These devices come with enable pins which can be used to put the respective outputs in high impedance for multi-master driving applications and to reduce power consumption. The ISO7740-Q1 device has all four channels in the same direction, the ISO7741-Q1 device has three forward and one reverse-direction channels, and the ISO7742-Q1 device has two forward and two reverse-direction channels. If the input power or signal is lost, default output is *high* for devices without suffix F and *low* for devices with suffix F. See the [Device Functional Modes](#) section for further details.

Used in conjunction with isolated power supplies, these devices help prevent noise currents on data buses, such as CAN and LIN, or other circuits from entering the local ground and interfering with or damaging sensitive circuitry. Through innovative chip design and layout techniques, electromagnetic compatibility of the ISO774x-Q1 devices have been significantly enhanced to ease system-level ESD, EFT, surge, and emissions compliance. The ISO774x-Q1 devices are available in 16-pin wide SOIC (DW) and QSOP (DBQ) packages. ISO7741-Q1 is also available in extra-wide SOIC (DWW) package.

6 Pin Configuration and Functions

**ISO7740-Q1 DW and DBQ Packages
16-Pin SOIC-WB and QSOP
Top View**

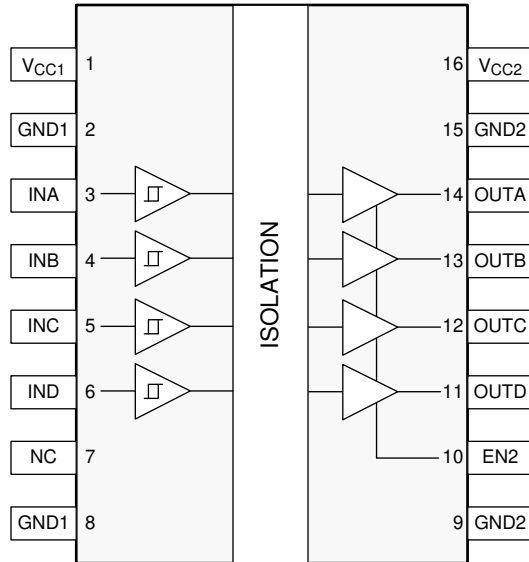

**ISO7741-Q1 DWW, DW and DBQ Packages
16-Pin SOIC-Extra-WB, SOIC-WB and QSOP
Top View**

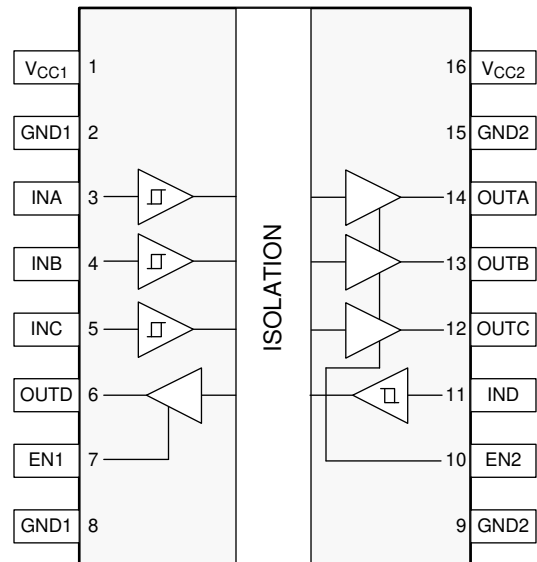

**ISO7742-Q1 DW and DBQ Packages
16-Pin SOIC-WB and QSOP
Top View**

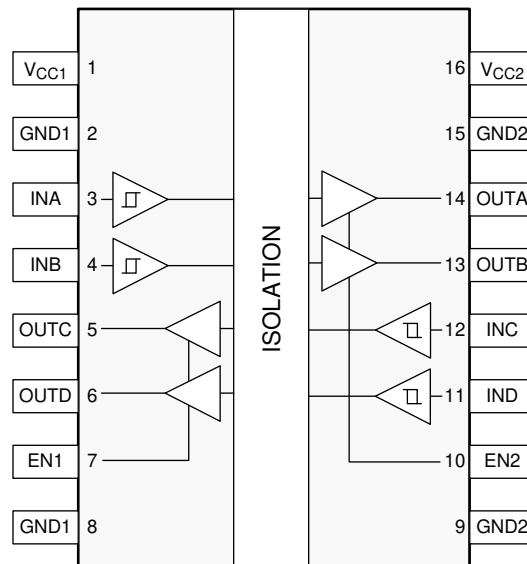

Pin Functions

NAME	PIN			I/O	DESCRIPTION
	ISO7740-Q1	ISO7741-Q1	ISO7742-Q1		
EN1	—	7	7	I	Output enable 1. Output pins on side 1 are enabled when EN1 is high or open and in high-impedance state when EN1 is low.
EN2	10	10	10	I	Output enable 2. Output pins on side 2 are enabled when EN2 is high or open and in high-impedance state when EN2 is low.
GND1	2	2	2	—	Ground connection for V_{CC1}
	8	8	8		
GND2	9	9	9	—	Ground connection for V_{CC2}
	15	15	15		
INA	3	3	3	I	Input, channel A
INB	4	4	4	I	Input, channel B
INC	5	5	12	I	Input, channel C
IND	6	11	11	I	Input, channel D
NC	7	—	—	—	Not connected
OUTA	14	14	14	O	Output, channel A
OUTB	13	13	13	O	Output, channel B
OUTC	12	12	5	O	Output, channel C
OUTD	11	6	6	O	Output, channel D
V_{CC1}	1	1	1	—	Power supply, side 1
V_{CC2}	16	16	16	—	Power supply, side 2

7 Specifications

7.1 Absolute Maximum Ratings

 See ⁽¹⁾

		MIN	MAX	UNIT
V_{CC1}, V_{CC2}	Supply voltage ⁽²⁾	-0.5	6	V
V	Voltage at INx, OUTx, ENx	-0.5	$V_{CCX} + 0.5^{(3)}$	V
I_O	Output current	-15	15	mA
T_J	Junction temperature		150	°C
T_{stg}	Storage temperature	-65	150	°C

- (1) Stresses beyond those listed under *Absolute Maximum Ratings* may cause permanent damage to the device. These are stress ratings only and functional operation of the device at these or any other conditions beyond those indicated under *Recommended Operating Conditions* is not implied. Exposure to absolute-maximum-rated conditions for extended periods may affect device reliability.
- (2) All voltage values except differential I/O bus voltages are with respect to the local ground terminal (GND1 or GND2) and are peak voltage values.
- (3) Maximum voltage must not exceed 6 V.

7.2 ESD Ratings

		VALUE	UNIT
$V_{(ESD)}$	Electrostatic discharge	Human-body model (HBM), per AEC Q100-002 ⁽¹⁾ HBM ESD Classification Level 3A	±6000
		Charged-device model (CDM), per AEC Q100-011 CDM ESD Classification Level C6	±1500
		Contact discharge per IEC 61000-4-2; Isolation barrier withstand test ⁽²⁾⁽³⁾	±8000

- (1) AEC Q100-002 indicates that HBM stressing shall be in accordance with the ANSI/ESDA/JEDEC JS-001 specification.
- (2) IEC ESD strike is applied across the barrier with all pins on each side tied together creating a two-terminal device.
- (3) Testing is carried out in air or oil to determine the intrinsic contact discharge capability of the device.

7.3 Recommended Operating Conditions

		MIN	NOM	MAX	UNIT
V_{CC1}, V_{CC2}	Supply voltage	2.25		5.5	V
$V_{CC(UVLO+)}$	UVLO threshold when supply voltage is rising		2	2.25	V
$V_{CC(UVLO-)}$	UVLO threshold when supply voltage is falling	1.7	1.8		V
$V_{HYS(UVLO)}$	Supply voltage UVLO hysteresis	100	200		mV
I_{OH}	High-level output current	$V_{CCO}^{(1)} = 5\text{ V}$		-4	mA
		$V_{CCO} = 3.3\text{ V}$		-2	
		$V_{CCO} = 2.5\text{ V}$		-1	
I_{OL}	Low-level output current	$V_{CCO} = 5\text{ V}$		4	mA
		$V_{CCO} = 3.3\text{ V}$		2	
		$V_{CCO} = 2.5\text{ V}$		1	
V_{IH}	High-level input voltage	$0.7 \times V_{CCI}^{(1)}$		V_{CCI}	V
V_{IL}	Low-level input voltage	0		$0.3 \times V_{CCI}$	V
DR	Data rate ⁽²⁾	0		100	Mbps
T_A	Ambient temperature	-40	25	125	°C

- (1) V_{CCI} = Input-side V_{CC} ; V_{CCO} = Output-side V_{CC} .
- (2) 100 Mbps is the maximum specified data rate, although higher data rates are possible.

7.4 Thermal Information

THERMAL METRIC ⁽¹⁾	ISO774x-Q1			UNIT
	DWW (SOIC)	DW (SOIC)	DBQ (QSOP)	
	16 Pins	16 Pins	16 Pins	
$R_{\theta JA}$ Junction-to-ambient thermal resistance	58.3	83.4	109	°C/W
$R_{\theta JC(top)}$ Junction-to-case(top) thermal resistance	21.4	46	54.4	°C/W
$R_{\theta JB}$ Junction-to-board thermal resistance	30.5	48	51.9	°C/W
Ψ_{JT} Junction-to-top characterization parameter	7.1	19.1	14.2	°C/W
Ψ_{JB} Junction-to-board characterization parameter	29.8	47.5	51.4	°C/W
$R_{\theta JC(bottom)}$ Junction-to-case(bottom) thermal resistance	—	—	—	°C/W

(1) For more information about traditional and new thermal metrics, see the [Semiconductor and IC Package Thermal Metrics application report](#).

7.5 Power Rating

PARAMETER	TEST CONDITIONS	MIN	TYP	MAX	UNIT
ISO7740-Q1					
P_D Maximum power dissipation	$V_{CC1} = V_{CC2} = 5.5\text{ V}$, $T_J = 150^\circ\text{C}$, $C_L = 15\text{ pF}$, Input a 50-MHz 50% duty cycle square wave			200	mW
P_{D1} Maximum power dissipation by side-1				40	mW
P_{D2} Maximum power dissipation by side-2				160	mW
ISO7741-Q1					
P_D Maximum power dissipation	$V_{CC1} = V_{CC2} = 5.5\text{ V}$, $T_J = 150^\circ\text{C}$, $C_L = 15\text{ pF}$, Input a 50-MHz 50% duty cycle square wave			200	mW
P_{D1} Maximum power dissipation by side-1				75	mW
P_{D2} Maximum power dissipation by side-2				125	mW
ISO7742-Q1					
P_D Maximum power dissipation	$V_{CC1} = V_{CC2} = 5.5\text{ V}$, $T_J = 150^\circ\text{C}$, $C_L = 15\text{ pF}$, Input a 50-MHz 50% duty cycle square wave			200	mW
P_{D1} Maximum power dissipation by side-1				100	mW
P_{D2} Maximum power dissipation by side-2				100	mW

7.6 Insulation Specifications

PARAMETER		TEST CONDITIONS	VALUE			UNIT
			DWW-16	DW-16	DBQ-16	
CLR	External clearance ⁽¹⁾	Shortest terminal-to-terminal distance through air	>14.5	>8	>3.7	mm
CPG	External creepage ⁽¹⁾	Shortest terminal-to-terminal distance across the package surface	>14.5	>8	>3.7	mm
DTI	Distance through the insulation	Minimum internal gap (internal clearance)	>21	>21	>21	μm
CTI	Comparative tracking index	DIN EN 60112 (VDE 0303-11); IEC 60112	>600	>600	>600	V
	Material group	According to IEC 60664-1	I	I	I	
	Overvoltage category per IEC 60664-1	Rated mains voltage ≤ 300 V _{RMS}	I-IV	I-IV	I-III	
		Rated mains voltage ≤ 600 V _{RMS}	I-IV	I-IV	n/a	
		Rated mains voltage ≤ 1000 V _{RMS}	I-IV	I-III	n/a	
DIN VDE V 0884-11:2017-01⁽²⁾						
V _{IORM}	Maximum repetitive peak isolation voltage	AC voltage (bipolar)	2828	2121	566	V _{PK}
V _{IOWM}	Maximum working isolation voltage	AC voltage; Time dependent dielectric breakdown (TDDB) Test; see Figure 30	2000	1500	400	V _{RMS}
		DC voltage	2828	2121	566	V _{DC}
V _{IOTM}	Maximum transient isolation voltage	V _{TEST} = V _{IOTM} , t = 60 s (qualification); V _{TEST} = 1.2 × V _{IOTM} , t = 1 s (100% production)	8000	8000	4242	V _{PK}
V _{IOSM}	Maximum surge isolation voltage ⁽³⁾	Test method per IEC 62368-1, 1.2/50 μs waveform, V _{TEST} = 1.6 × V _{IOSM} (qualification)	8000	8000	4000	V _{PK}
q _{pd}	Apparent charge ⁽⁴⁾	Method a, After Input/Output safety test subgroup 2/3, V _{ini} = V _{IOTM} , t _{ini} = 60 s; V _{pd(m)} = 1.2 × V _{IORM} , t _m = 10 s	≤5	≤5	≤5	pC
		Method a, After environmental tests subgroup 1, V _{ini} = V _{IOTM} , t _{ini} = 60 s; V _{pd(m)} = 1.6 × V _{IORM} , t _m = 10 s	≤5	≤5	≤5	
		Method b1; At routine test (100% production) and preconditioning (type test) V _{ini} = 1.2 × V _{IOTM} , t _{ini} = 1 s; V _{pd(m)} = 1.875 × V _{IORM} , t _m = 1 s	≤5	≤5	≤5	
C _{IO}	Barrier capacitance, input to output ⁽⁵⁾	V _{IO} = 0.4 × sin(2πft), f = 1 MHz	~1	~1	~1	pF
R _{IO}	Isolation resistance ⁽⁵⁾	V _{IO} = 500 V, T _A = 25°C	>10 ¹²	>10 ¹²	>10 ¹²	Ω
		V _{IO} = 500 V, 100°C ≤ T _A ≤ 125°C	>10 ¹¹	>10 ¹¹	>10 ¹¹	
		V _{IO} = 500 V at T _S = 150°C	>10 ⁹	>10 ⁹	>10 ⁹	
	Pollution degree		2	2	2	
	Climatic category		55/125/21	55/125/21	55/125/21	
UL 1577						
V _{ISO}	Maximum withstanding isolation voltage	V _{TEST} = V _{ISO} , t = 60 s (qualification), V _{TEST} = 1.2 × V _{ISO} , t = 1 s (100% production)	5700	5000	3000	V _{RMS}

- (1) Creepage and clearance requirements should be applied according to the specific equipment isolation standards of an application. Care should be taken to maintain the creepage and clearance distance of a board design to ensure that the mounting pads of the isolator on the printed-circuit board do not reduce this distance. Creepage and clearance on a printed-circuit board become equal in certain cases. Techniques such as inserting grooves and/or ribs on a printed circuit board are used to help increase these specifications.
- (2) This coupler is suitable for *safe electrical insulation* only within the safety ratings. Compliance with the safety ratings shall be ensured by means of suitable protective circuits.
- (3) Testing is carried out in air or oil to determine the intrinsic surge immunity of the isolation barrier.
- (4) Apparent charge is electrical discharge caused by a partial discharge (pd).
- (5) All pins on each side of the barrier tied together creating a two-terminal device.

7.7 Safety-Related Certifications

VDE	CSA	UL	CQC	TUV
Certified according to DIN VDE V 0884-11:2017-01	Certified according to IEC 60950-1, IEC 62368-1 and IEC 60601-1	Certified according to UL 1577 Component Recognition Program	Certified according to GB 4943.1-2011	Certified according to EN 61010-1:2010/A1:2019, EN 60950-1:2006/A2:2013 and EN 62368-1:2014
Maximum transient isolation voltage, 8000 V _{PK} (DWW-16, DW-16) and 4242 V _{PK} (DBQ-16); Maximum repetitive peak isolation voltage, 2828 V _{PK} (DWW-16, Reinforced), 2121 V _{PK} (DW-16, Reinforced) and 566 V _{PK} (DBQ-16); Maximum surge isolation voltage, 8000 V _{PK} (DWW-16, DW-16) and 4000 V _{PK} (DBQ-16)	Reinforced insulation per CSA 60950-1-07+A1+A2, IEC 60950-1-14 and IEC 62368-1 2nd Ed. 1450 V _{RMS} (DWW-16), 800 V _{RMS} (DW-16) and 370 V _{RMS} (DBQ-16) max working voltage (pollution degree 2, material group I); 2 MOPP (Means of Patient Protection) per CSA 60601-1:14 and IEC 60601-1 Ed. 3.1, 400 V _{RMS} (DWW-16) and 250 V _{RMS} (DW-16) max working voltage	DW-16: Single protection, 5000 V _{RMS} ; DBQ-16: Single protection, 3000 V _{RMS}	DWW-16: Reinforced Insulation, Altitude ≤ 5000 m, Tropical Climate, 1450 V _{RMS} maximum working voltage; DW-16: Reinforced Insulation, Altitude ≤ 5000 m, Tropical Climate, 700 V _{RMS} maximum working voltage; DBQ-16: Basic Insulation, Altitude ≤ 5000 m, Tropical Climate, 400 V _{RMS} maximum working voltage	5700 V _{RMS} (DWW-16), 5000 V _{RMS} (DW-16) and 3000 V _{RMS} (DBQ-16) Reinforced insulation per EN 61010-1:2010/A1:2019 up to working voltage of 1000 V _{RMS} (DWW-16), 600 V _{RMS} (DW-16) and 300 V _{RMS} (DBQ-16) 5700 V _{RMS} (DWW-16), 5000 V _{RMS} (DW-16) and 3000 V _{RMS} (DBQ-16) Reinforced insulation per EN 60950-1:2006/A2:2013 and EN 62368-1:2014 up to working voltage of 1450 V _{RMS} (DWW-16), 800 V _{RMS} (DW-16) and 370 V _{RMS} (DBQ-16)
Certificate number: 40040142	Master contract number: 220991	File number: E181974	Certificate numbers: CQC15001121716 (DWx-16) CQC18001199097 (DBQ-16)	Client ID number: 77311

7.8 Safety Limiting Values

Safety limiting⁽¹⁾ intends to minimize potential damage to the isolation barrier upon failure of input or output circuitry. A failure of the I/O can allow low resistance to ground or the supply and, without current limiting, dissipate sufficient power to overheat the die and damage the isolation barrier potentially leading to secondary system failures.

PARAMETER		TEST CONDITIONS	MIN	TYP	MAX	UNIT
DWW-16 PACKAGE						
I _S	Safety input, output, or supply current	R _{θJA} = 58.3 °C/W, V _I = 5.5 V, T _J = 150°C, T _A = 25°C, see Figure 1			390	mA
		R _{θJA} = 58.3 °C/W, V _I = 3.6 V, T _J = 150°C, T _A = 25°C, see Figure 1			596	
		R _{θJA} = 58.3 °C/W, V _I = 2.75 V, T _J = 150°C, T _A = 25°C, see Figure 1			780	
P _S	Safety input, output, or total power	R _{θJA} = 58.3 °C/W, T _J = 150°C, T _A = 25°C, see Figure 4			2144	mW
T _S	Maximum safety temperature				150	°C
DW-16 PACKAGE						
I _S	Safety input, output, or supply current	R _{θJA} = 83.4 °C/W, V _I = 5.5 V, T _J = 150°C, T _A = 25°C, see Figure 2			273	mA
		R _{θJA} = 83.4 °C/W, V _I = 3.6 V, T _J = 150°C, T _A = 25°C, see Figure 2			416	
		R _{θJA} = 83.4 °C/W, V _I = 2.75 V, T _J = 150°C, T _A = 25°C, see Figure 2			545	
P _S	Safety input, output, or total power	R _{θJA} = 83.4 °C/W, T _J = 150°C, T _A = 25°C, see Figure 5			1499	mW
T _S	Maximum safety temperature				150	°C
DBQ-16 PACKAGE						
I _S	Safety input, output, or supply current	R _{θJA} = 109 °C/W, V _I = 5.5 V, T _J = 150°C, T _A = 25°C, see Figure 3			209	mA
		R _{θJA} = 109 °C/W, V _I = 3.6 V, T _J = 150°C, T _A = 25°C, see Figure 3			319	
		R _{θJA} = 109 °C/W, V _I = 2.75 V, T _J = 150°C, T _A = 25°C, see Figure 3			417	
P _S	Safety input, output, or total power	R _{θJA} = 109 °C/W, T _J = 150°C, T _A = 25°C, see Figure 6			1147	mW
T _S	Maximum safety temperature				150	°C

(1) The maximum safety temperature is the maximum junction temperature specified for the device. The power dissipation and junction-to-air thermal impedance of the device installed in the application hardware determines the junction temperature. The assumed junction-to-air thermal resistance in the [Thermal Information](#) is that of a device installed on a High-K test board for leaded Surface Mount Packages. The power is the recommended maximum input voltage times the current. The junction temperature is then the ambient temperature plus the power times the junction-to-air thermal resistance

7.9 Electrical Characteristics—5-V Supply

$V_{CC1} = V_{CC2} = 5\text{ V} \pm 10\%$ (over recommended operating conditions unless otherwise noted)

PARAMETER	TEST CONDITIONS	MIN	TYP	MAX	UNIT
V_{OH}	High-level output voltage $I_{OH} = -4\text{ mA}$; see Figure 17	$V_{CCO}^{(1)} - 0.4$	4.8		V
V_{OL}	Low-level output voltage $I_{OL} = 4\text{ mA}$; see Figure 17		0.2	0.4	V
$V_{IT+(IN)}$	Rising input voltage threshold		$0.6 \times V_{CCI}$	$0.7 \times V_{CCI}$	V
$V_{IT-(IN)}$	Falling input voltage threshold	$0.3 \times V_{CCI}$	$0.4 \times V_{CCI}$		V
$V_{I(HYS)}$	Input threshold voltage hysteresis	$0.1 \times V_{CCI}$	$0.2 \times V_{CCI}$		V
I_{IH}	High-level input current $V_{IH} = V_{CCI}^{(1)}$ at INx or ENx			10	μA
I_{IL}	Low-level input current $V_{IL} = 0\text{ V}$ at INx or ENx	-10			μA
CMTI	Common-mode transient immunity $V_I = V_{CCI}$ or 0 V , $V_{CM} = 1200\text{ V}$; see Figure 20	85	100		$\text{kV}/\mu\text{s}$
C_I	Input Capacitance ⁽²⁾ $V_I = V_{CC}/2 + 0.4 \times \sin(2\pi ft)$, $f = 1\text{ MHz}$, $V_{CC} = 5\text{ V}$		2		pF

(1) V_{CCI} = Input-side V_{CC} ; V_{CCO} = Output-side V_{CC} .

(2) Measured from input pin to ground.

7.10 Supply Current Characteristics—5-V Supply

 $V_{CC1} = V_{CC2} = 5\text{ V} \pm 10\%$ (over recommended operating conditions unless otherwise noted).

PARAMETER	TEST CONDITIONS	SUPPLY CURRENT	MIN	TYP	MAX	UNIT	
ISO7740-Q1							
Supply current - Disable	EN2 = 0 V; $V_I = V_{CC1}$ (ISO7740-Q1); $V_I = 0\text{ V}$ (ISO7740-Q1 with F suffix)	I_{CC1}		1.2	1.6	mA	
		I_{CC2}		0.3	0.5		
	EN2 = 0 V; $V_I = 0\text{ V}$ (ISO7740-Q1); $V_I = V_{CC1}$ (ISO7740-Q1 with F suffix)	I_{CC1}		5.5	7.8		
		I_{CC2}		0.3	0.5		
Supply current - DC signal	EN2 = V_{CC2} ; $V_I = V_{CC1}$ (ISO7740-Q1); $V_I = 0\text{ V}$ (ISO7740-Q1 with F suffix)	I_{CC1}		1.2	1.6		
		I_{CC2}		2	3.2		
	EN2 = V_{CC2} ; $V_I = 0\text{ V}$ (ISO7740-Q1); $V_I = V_{CC1}$ (ISO7740-Q1 with F suffix)	I_{CC1}		5.5	7.8		
		I_{CC2}		2.2	3.6		
Supply current - AC signal	All channels switching with square wave clock input; $C_L = 15\text{ pF}$	1 Mbps	I_{CC1}		3.3	4.7	
			I_{CC2}		2.3	3.6	
		10 Mbps	I_{CC1}		3.4	4.8	
			I_{CC2}		4.2	5.8	
		100 Mbps	I_{CC1}		3.8	5.7	
			I_{CC2}		22.7	28	
ISO7741-Q1							
Supply current - Disable	EN1 = EN2 = 0 V; $V_I = V_{CCI}^{(1)}$ (ISO7741-Q1); $V_I = 0\text{ V}$ (ISO7741-Q1 with F suffix)	I_{CC1}		1	1.5	mA	
		I_{CC2}		0.8	1.1		
	EN1 = EN2 = 0 V; $V_I = 0\text{ V}$ (ISO7741-Q1); $V_I = V_{CCI}$ (ISO7741-Q1 with F suffix)	I_{CC1}		4.3	6.3		
		I_{CC2}		1.8	2.7		
Supply current - DC signal	EN1 = EN2 = V_{CCI} ; $V_I = V_{CCI}$ (ISO7741-Q1); $V_I = 0\text{ V}$ (ISO7741-Q1 with F suffix)	I_{CC1}		1.5	2.3		
		I_{CC2}		2	3		
	EN1 = EN2 = V_{CCI} ; $V_I = 0\text{ V}$ (ISO7741-Q1); $V_I = V_{CCI}$ (ISO7741-Q1 with F suffix)	I_{CC1}		4.8	6.8		
		I_{CC2}		3.2	4.9		
Supply current - AC signal	All channels switching with square wave clock input; $C_L = 15\text{ pF}$	1 Mbps	I_{CC1}		3.2	4.6	
			I_{CC2}		2.8	4.1	
		10 Mbps	I_{CC1}		3.7	5.2	
			I_{CC2}		4.2	5.7	
		100 Mbps	I_{CC1}		8.6	11.3	
			I_{CC2}		18	22	
ISO7742-Q1							
Supply current - Disable	EN1 = EN2 = 0 V; $V_I = V_{CCI}$ (ISO7742-Q1); $V_I = 0\text{ V}$ (ISO7742-Q1 with F suffix)	I_{CC1}, I_{CC2}		0.9	1.3	mA	
	EN1 = EN2 = 0 V; $V_I = 0\text{ V}$ (ISO7742-Q1); $V_I = V_{CCI}$ (ISO7742-Q1 with F suffix)	I_{CC1}, I_{CC2}		3	4.6		
Supply current - DC signal	EN1 = EN2 = V_{CCI} ; $V_I = V_{CCI}$ (ISO7742-Q1); $V_I = 0\text{ V}$ (ISO7742-Q1 with F suffix)	I_{CC1}, I_{CC2}		1.7	2.7		
	EN1 = EN2 = V_{CCI} ; $V_I = 0\text{ V}$ (ISO7742-Q1); $V_I = V_{CCI}$ (ISO7742-Q1 with F suffix)	I_{CC1}, I_{CC2}		4	5.9		
Supply current - AC signal	All channels switching with square wave clock input; $C_L = 15\text{ pF}$	1 Mbps	I_{CC1}, I_{CC2}		3		4.4
		10 Mbps	I_{CC1}, I_{CC2}		4		5.5
		100 Mbps	I_{CC1}, I_{CC2}		13.4	17	

 (1) $V_{CCI} = \text{Input-side } V_{CC}$

7.11 Electrical Characteristics—3.3-V Supply

$V_{CC1} = V_{CC2} = 3.3 \text{ V} \pm 10\%$ (over recommended operating conditions unless otherwise noted)

PARAMETER		TEST CONDITIONS	MIN	TYP	MAX	UNIT
V_{OH}	High-level output voltage	$I_{OH} = -2 \text{ mA}$; see Figure 17	$V_{CCO}^{(1)} - 0.3$	3.2		V
V_{OL}	Low-level output voltage	$I_{OL} = 2 \text{ mA}$; see Figure 17		0.1	0.3	V
$V_{IT+(IN)}$	Rising input voltage threshold			$0.6 \times V_{CCI}$	$0.7 \times V_{CCI}$	V
$V_{IT-(IN)}$	Falling input voltage threshold		$0.3 \times V_{CCI}$	$0.4 \times V_{CCI}$		V
$V_{I(HYS)}$	Input threshold voltage hysteresis		$0.1 \times V_{CCI}$	$0.2 \times V_{CCI}$		V
I_{IH}	High-level input current	$V_{IH} = V_{CCI}^{(1)}$ at INx or ENx			10	μA
I_{IL}	Low-level input current	$V_{IL} = 0 \text{ V}$ at INx or ENx	-10			μA
CMTI	Common-mode transient immunity	$V_I = V_{CCI}$ or 0 V , $V_{CM} = 1200 \text{ V}$; see Figure 20	85	100		$\text{kV}/\mu\text{s}$

(1) V_{CCI} = Input-side V_{CC} ; V_{CCO} = Output-side V_{CC} .

7.12 Supply Current Characteristics—3.3-V Supply

 $V_{CC1} = V_{CC2} = 3.3 \text{ V} \pm 10\%$ (over recommended operating conditions unless otherwise noted).

PARAMETER	TEST CONDITIONS	SUPPLY CURRENT	MIN	TYP	MAX	UNIT	
ISO7740-Q1							
Supply current - Disable	EN2 = 0 V; $V_I = V_{CC1}$ (ISO7740-Q1); $V_I = 0 \text{ V}$ (ISO7740-Q1 with F suffix)	I_{CC1}		1.2	1.6	mA	
		I_{CC2}		0.3	0.5		
	EN2 = 0 V; $V_I = 0 \text{ V}$ (ISO7740-Q1); $V_I = V_{CC1}$ (ISO7740-Q1 with F suffix)	I_{CC1}		5.5	7.8		
		I_{CC2}		0.3	0.5		
Supply current - DC signal	EN2 = V_{CC2} ; $V_I = V_{CC1}$ (ISO7740-Q1); $V_I = 0 \text{ V}$ (ISO7740-Q1 with F suffix)	I_{CC1}		1.2	1.6		
		I_{CC2}		1.9	3.2		
	EN2 = V_{CC2} ; $V_I = 0 \text{ V}$ (ISO7740-Q1); $V_I = V_{CC1}$ (ISO7740-Q1 with F suffix)	I_{CC1}		5.5	7.8		
		I_{CC2}		2.2	3.6		
Supply current - AC signal	All channels switching with square wave clock input; $C_L = 15 \text{ pF}$	1 Mbps	I_{CC1}		3.3		4.7
			I_{CC2}		2.2		3.6
		10 Mbps	I_{CC1}		3.4		4.8
			I_{CC2}		3.6		5
		100 Mbps	I_{CC1}		3.3	5.5	
			I_{CC2}		17	20	
ISO7741-Q1							
Supply current - Disable	EN1 = EN2 = 0 V; $V_I = V_{CCI}^{(1)}$ (ISO7741-Q1); $V_I = 0 \text{ V}$ (ISO7741-Q1 with F suffix)	I_{CC1}		1	1.5	mA	
		I_{CC2}		0.8	1.1		
	EN1 = EN2 = 0 V; $V_I = 0 \text{ V}$ (ISO7741-Q1); $V_I = V_{CCI}$ (ISO7741-Q1 with F suffix)	I_{CC1}		4.3	6.3		
		I_{CC2}		1.9	2.7		
Supply current - DC signal	EN1 = EN2 = V_{CCI} ; $V_I = V_{CCI}$ (ISO7741-Q1); $V_I = 0 \text{ V}$ (ISO7741-Q1 with F suffix)	I_{CC1}		1.5	2.3		
		I_{CC2}		2	3		
	EN1 = EN2 = V_{CCI} ; $V_I = 0 \text{ V}$ (ISO7741-Q1); $V_I = V_{CCI}$ (ISO7741-Q1 with F suffix)	I_{CC1}		4.8	6.8		
		I_{CC2}		3.2	4.9		
Supply current - AC signal	All channels switching with square wave clock input; $C_L = 15 \text{ pF}$	1 Mbps	I_{CC1}		3.2		4.6
			I_{CC2}		2.7		4.1
		10 Mbps	I_{CC1}		3.5		5
			I_{CC2}		3.7		5.2
		100 Mbps	I_{CC1}		6.8	9.3	
			I_{CC2}		13.7	16.4	
ISO7742-Q1							
Supply current - Disable	EN1 = EN2 = 0 V; $V_I = V_{CCI}$ (ISO7742-Q1); $V_I = 0 \text{ V}$ (ISO7742-Q1 with F suffix)	I_{CC1}, I_{CC2}		0.9	1.3	mA	
		I_{CC1}, I_{CC2}		3	4.6		
Supply current - DC signal	EN1 = EN2 = V_{CCI} ; $V_I = V_{CCI}$ (ISO7742-Q1); $V_I = 0 \text{ V}$ (ISO7742-Q1 with F suffix)	I_{CC1}, I_{CC2}		1.7	2.7		
		I_{CC1}, I_{CC2}		4	5.9		
Supply current - AC signal	All channels switching with square wave clock input; $C_L = 15 \text{ pF}$	1 Mbps	I_{CC1}, I_{CC2}		2.9		4.3
		10 Mbps	I_{CC1}, I_{CC2}		3.6		5.1
		100 Mbps	I_{CC1}, I_{CC2}		10.3		13

 (1) V_{CCI} = Input-side V_{CC}

7.13 Electrical Characteristics—2.5-V Supply

 $V_{CC1} = V_{CC2} = 2.5\text{ V} \pm 10\%$ (over recommended operating conditions unless otherwise noted)

PARAMETER		TEST CONDITIONS	MIN	TYP	MAX	UNIT
V_{OH}	High-level output voltage	$I_{OH} = -1\text{ mA}$; see Figure 17	$V_{CCO}^{(1)} - 0.2$	2.45		V
V_{OL}	Low-level output voltage	$I_{OL} = 1\text{ mA}$; see Figure 17		0.05	0.2	V
$V_{IT+(IN)}$	Rising input voltage threshold			$0.6 \times V_{CCI}$	$0.7 \times V_{CCI}$	V
$V_{IT-(IN)}$	Falling input voltage threshold		$0.3 \times V_{CCI}$	$0.4 \times V_{CCI}$		V
$V_{I(HYS)}$	Input threshold voltage hysteresis		$0.1 \times V_{CCI}$	$0.2 \times V_{CCI}$		V
I_{IH}	High-level input current	$V_{IH} = V_{CCI}^{(1)}$ at INx or ENx			10	μA
I_{IL}	Low-level input current	$V_{IL} = 0\text{ V}$ at INx or ENx	-10			μA
CMTI	Common-mode transient immunity	$V_I = V_{CCI}$ or 0 V , $V_{CM} = 1200\text{ V}$; see Figure 20	85	100		$\text{kV}/\mu\text{s}$

(1) V_{CCI} = Input-side V_{CC} ; V_{CCO} = Output-side V_{CC} .

7.14 Supply Current Characteristics—2.5-V Supply

 $V_{CC1} = V_{CC2} = 2.5 \text{ V} \pm 10\%$ (over recommended operating conditions unless otherwise noted).

PARAMETER	TEST CONDITIONS		SUPPLY CURRENT	MIN	TYP	MAX	UNIT
ISO7740-Q1							
Supply current - Disable	EN2 = 0 V; V _I = V _{CC1} (ISO7740-Q1); V _I = 0 V (ISO7740-Q1 with F suffix)		I _{CC1}		1.2	1.6	mA
			I _{CC2}		0.3	0.5	
	EN2 = 0 V; V _I = 0 V (ISO7740-Q1); V _I = V _{CC1} (ISO7740-Q1 with F suffix)		I _{CC1}		5.5	7.8	
			I _{CC2}		0.3	0.5	
Supply current - DC signal	EN2 = V _{CC2} ; V _I = V _{CC1} (ISO7740-Q1); V _I = 0 V (ISO7740-Q1 with F suffix)		I _{CC1}		1.2	1.6	
			I _{CC2}		1.9	3.2	
	EN2 = V _{CC2} ; V _I = 0 V (ISO7740-Q1); V _I = V _{CC1} (ISO7740-Q1 with F suffix)		I _{CC1}		5.4	7.8	
			I _{CC2}		2.2	3.6	
Supply current - AC signal	All channels switching with square wave clock input; C _L = 15 pF	1 Mbps	I _{CC1}		3.3	4.7	
			I _{CC2}		2.2	3.5	
		10 Mbps	I _{CC1}		3.4	4.8	
			I _{CC2}		3.2	4.7	
		100 Mbps	I _{CC1}		3.2	5.4	
			I _{CC2}		13	17	
ISO7741-Q1							
Supply current - Disable	EN1 = EN2 = 0 V; V _I = V _{CCI} ⁽¹⁾ (ISO7741-Q1); V _I = 0 V (ISO7741-Q1 with F suffix)		I _{CC1}		1	1.5	mA
			I _{CC2}		0.8	1.1	
	EN1 = EN2 = 0 V; V _I = 0 V (ISO7741-Q1); V _I = V _{CCI} (ISO7741-Q1 with F suffix)		I _{CC1}		4.3	6.3	
			I _{CC2}		1.8	2.7	
Supply current - DC signal	EN1 = EN2 = V _{CCI} ; V _I = V _{CCI} (ISO7741-Q1); V _I = 0 V (ISO7741-Q1 with F suffix)		I _{CC1}		1.4	2.3	
			I _{CC2}		2	3	
	EN1 = EN2 = V _{CCI} ; V _I = 0 V (ISO7741-Q1); V _I = V _{CCI} (ISO7741-Q1 with F suffix)		I _{CC1}		4.7	6.8	
			I _{CC2}		3.2	4.9	
Supply current - AC signal	All channels switching with square wave clock input; C _L = 15 pF	1 Mbps	I _{CC1}		3.1	4.6	
			I _{CC2}		2.7	4	
		10 Mbps	I _{CC1}		3.4	4.9	
			I _{CC2}		3.5	4.9	
		100 Mbps	I _{CC1}		5.6	8.3	
			I _{CC2}		10.8	13.8	
ISO7742-Q1							
Supply current - Disable	EN1 = EN2 = 0 V; V _I = V _{CCI} (ISO7742-Q1); V _I = 0 V (ISO7742-Q1 with F suffix)		I _{CC1} , I _{CC2}		0.9	1.3	mA
	EN1 = EN2 = 0 V; V _I = 0 V (ISO7742-Q1); V _I = V _{CCI} (ISO7742-Q1 with F suffix)		I _{CC1} , I _{CC2}		3	4.6	
Supply current - DC signal	EN1 = EN2 = V _{CCI} ; V _I = V _{CCI} (ISO7742-Q1); V _I = 0 V (ISO7742-Q1 with F suffix)		I _{CC1} , I _{CC2}		1.7	2.7	
	EN1 = EN2 = V _{CCI} ; V _I = 0 V (ISO7742-Q1); V _I = V _{CCI} (ISO7742-Q1 with F suffix)		I _{CC1} , I _{CC2}		4	5.9	
Supply current - AC signal	All channels switching with square wave clock input; C _L = 15 pF	1 Mbps	I _{CC1} , I _{CC2}		2.9	4.3	
		10 Mbps	I _{CC1} , I _{CC2}		3.4	4.9	
		100 Mbps	I _{CC1} , I _{CC2}		8.3	11.5	

 (1) V_{CCI} = Input-side V_{CC}

7.15 Switching Characteristics—5-V Supply

 $V_{CC1} = V_{CC2} = 5\text{ V} \pm 10\%$ (over recommended operating conditions unless otherwise noted)

PARAMETER		TEST CONDITIONS	MIN	TYP	MAX	UNIT
t_{PLH} , t_{PHL}	Propagation delay time	See Figure 17	6	10.7	16	ns
PWD	Pulse width distortion ⁽¹⁾ $ t_{PHL} - t_{PLH} $		0	4.9	ns	
$t_{sk(o)}$	Channel-to-channel output skew time ⁽²⁾	Same-direction channels			4	ns
$t_{sk(pp)}$	Part-to-part skew time ⁽³⁾				4.4	ns
t_r	Output signal rise time	See Figure 17		2.4	3.9	ns
t_f	Output signal fall time			2.4	3.9	ns
t_{PHZ}	Disable propagation delay, high-to-high impedance output	See Figure 18		9	20	ns
t_{PLZ}	Disable propagation delay, low-to-high impedance output			9	20	ns
t_{PZH}	Enable propagation delay, high impedance-to-high output for ISO774x-Q1			7	20	ns
	Enable propagation delay, high impedance-to-high output for ISO774x-Q1 with F suffix			3	8.5	μs
t_{PZL}	Enable propagation delay, high impedance-to-low output for ISO774x-Q1			3	8.5	μs
	Enable propagation delay, high impedance-to-low output for ISO774x-Q1 with F suffix			7	20	ns
t_{DO}	Default output delay time from input power loss	Measured from the time V_{CC} goes below 1.7 V. See Figure 20		0.1	0.3	μs
t_{ie}	Time interval error	$2^{16} - 1$ PRBS data at 100 Mbps		0.8		ns

- (1) Also known as pulse skew.
- (2) $t_{sk(o)}$ is the skew between outputs of a single device with all driving inputs connected together and the outputs switching in the same direction while driving identical loads.
- (3) $t_{sk(pp)}$ is the magnitude of the difference in propagation delay times between any terminals of different devices switching in the same direction while operating at identical supply voltages, temperature, input signals and loads.

7.16 Switching Characteristics—3.3-V Supply

 $V_{CC1} = V_{CC2} = 3.3\text{ V} \pm 10\%$ (over recommended operating conditions unless otherwise noted)

PARAMETER		TEST CONDITIONS	MIN	TYP	MAX	UNIT
t_{PLH} , t_{PHL}	Propagation delay time	See Figure 17	6	11	16	ns
PWD	Pulse width distortion ⁽¹⁾ $ t_{PHL} - t_{PLH} $		0.1	5	ns	
$t_{sk(o)}$	Channel-to-channel output skew time ⁽²⁾	Same-direction channels			4.1	ns
$t_{sk(pp)}$	Part-to-part skew time ⁽³⁾				4.5	ns
t_r	Output signal rise time	See Figure 17		1.3	3	ns
t_f	Output signal fall time			1.3	3	ns
t_{PHZ}	Disable propagation delay, high-to-high impedance output	See Figure 18		17	30	ns
t_{PLZ}	Disable propagation delay, low-to-high impedance output			17	30	ns
t_{PZH}	Enable propagation delay, high impedance-to-high output for ISO774x-Q1			17	30	ns
	Enable propagation delay, high impedance-to-high output for ISO774x-Q1 with F suffix			3.2	8.5	μs
t_{PZL}	Enable propagation delay, high impedance-to-low output for ISO774x-Q1			3.2	8.5	μs
	Enable propagation delay, high impedance-to-low output for ISO774x-Q1 with F suffix			17	30	ns
t_{DO}	Default output delay time from input power loss	Measured from the time V_{CC} goes below 1.7 V. See Figure 20		0.1	0.3	μs
t_{ie}	Time interval error	$2^{16} - 1$ PRBS data at 100 Mbps		0.9		ns

- (1) Also known as pulse skew.
- (2) $t_{sk(o)}$ is the skew between outputs of a single device with all driving inputs connected together and the outputs switching in the same direction while driving identical loads.
- (3) $t_{sk(pp)}$ is the magnitude of the difference in propagation delay times between any terminals of different devices switching in the same direction while operating at identical supply voltages, temperature, input signals and loads.

7.17 Switching Characteristics—2.5-V Supply

 $V_{CC1} = V_{CC2} = 2.5\text{ V} \pm 10\%$ (over recommended operating conditions unless otherwise noted)

PARAMETER		TEST CONDITIONS	MIN	TYP	MAX	UNIT	
t_{PLH}, t_{PHL}	Propagation delay time	See Figure 17	7.5	12	18.5	ns	
PWD	Pulse width distortion ⁽¹⁾ $ t_{PHL} - t_{PLH} $		0.2	5.1		ns	
$t_{sk(o)}$	Channel-to-channel output skew time ⁽²⁾	Same-direction Channels			4.1	ns	
$t_{sk(pp)}$	Part-to-part skew time ⁽³⁾				4.6	ns	
t_r	Output signal rise time	See Figure 17		1	3.5	ns	
t_f	Output signal fall time			1	3.5	ns	
t_{PHZ}	Disable propagation delay, high-to-high impedance output	See Figure 18		22	40	ns	
t_{PLZ}	Disable propagation delay, low-to-high impedance output			22	40	ns	
t_{PZH}	Enable propagation delay, high impedance-to-high output for ISO774x-Q1				18	40	ns
	Enable propagation delay, high impedance-to-high output for ISO774x-Q1 with F suffix				3.3	8.5	μs
t_{PZL}	Enable propagation delay, high impedance-to-low output for ISO774x-Q1				3.3	8.5	μs
	Enable propagation delay, high impedance-to-low output for ISO774x-Q1 with F suffix				18	40	ns
t_{DO}	Default output delay time from input power loss	Measured from the time V_{CC} goes below 1.7 V. See Figure 20		0.1	0.3	μs	
t_{ie}	Time interval error	$2^{16} - 1$ PRBS data at 100 Mbps		0.7		ns	

- (1) Also known as pulse skew.
- (2) $t_{sk(o)}$ is the skew between outputs of a single device with all driving inputs connected together and the outputs switching in the same direction while driving identical loads.
- (3) $t_{sk(pp)}$ is the magnitude of the difference in propagation delay times between any terminals of different devices switching in the same direction while operating at identical supply voltages, temperature, input signals and loads.

7.18 Insulation Characteristics Curves

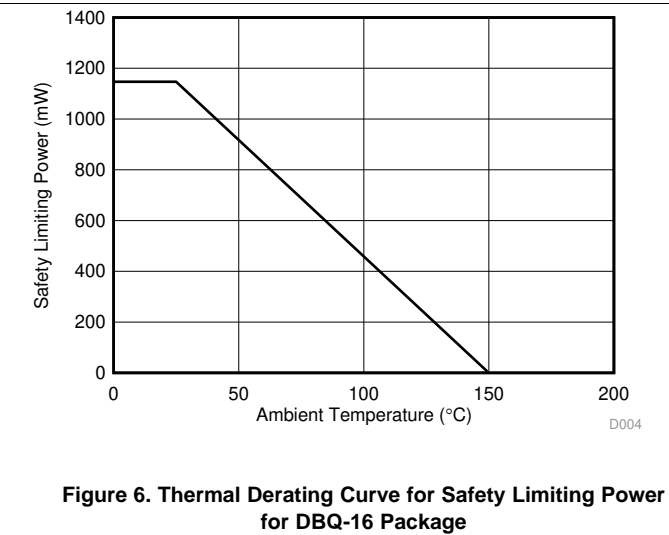
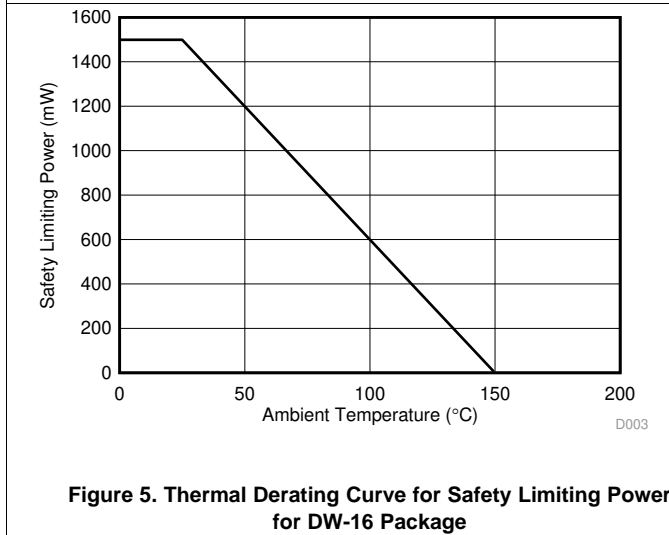
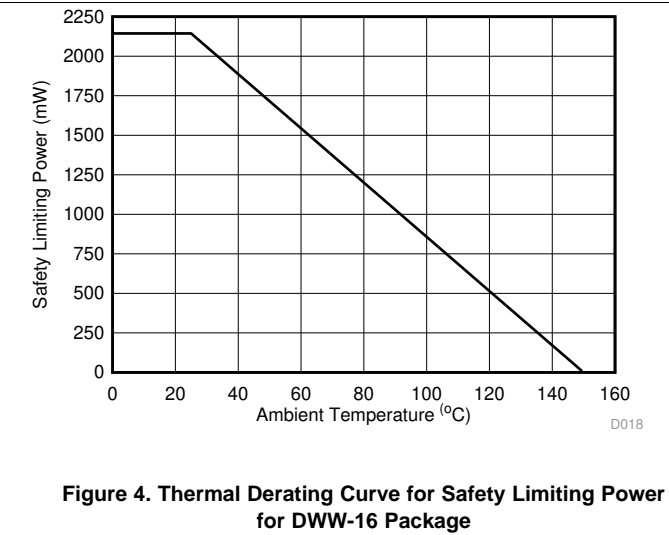
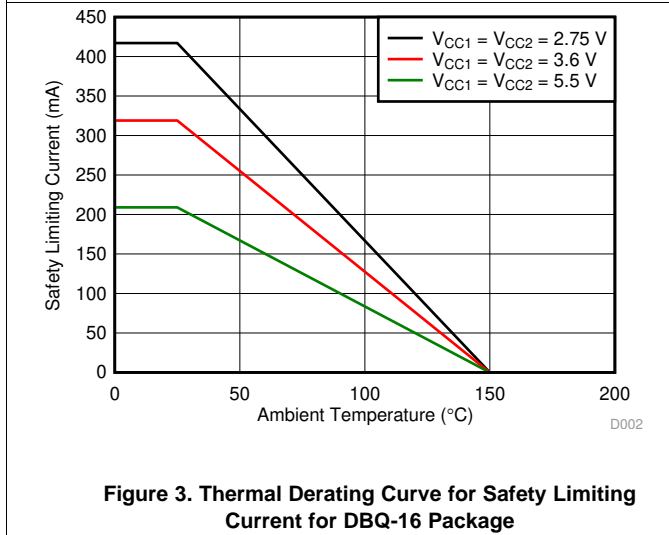
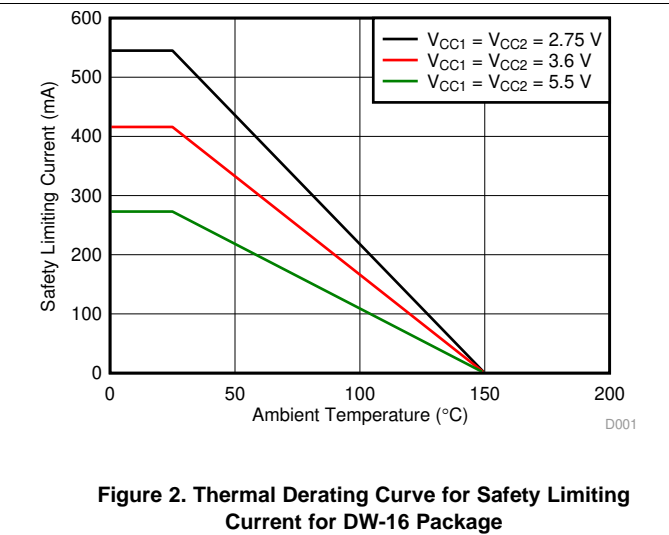
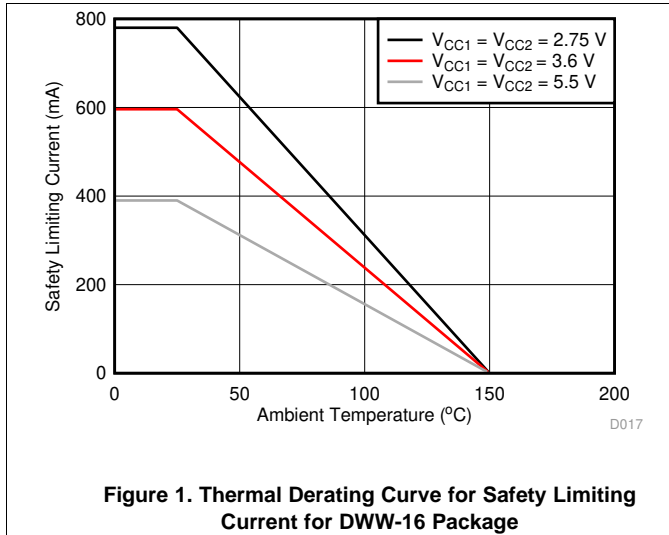

7.19 Typical Characteristics

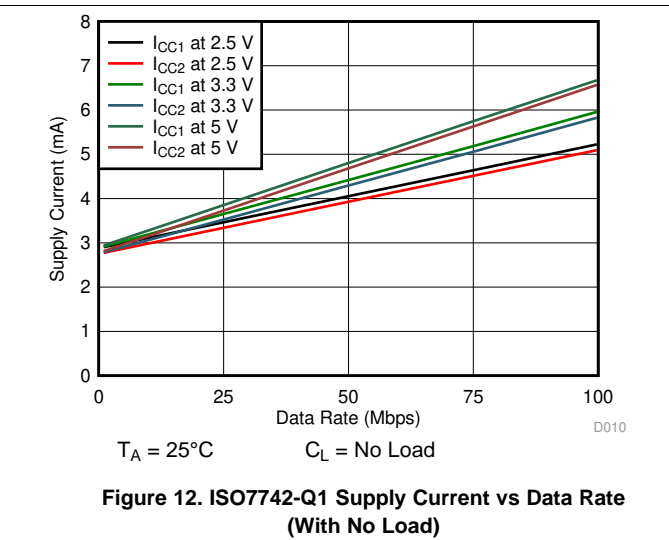
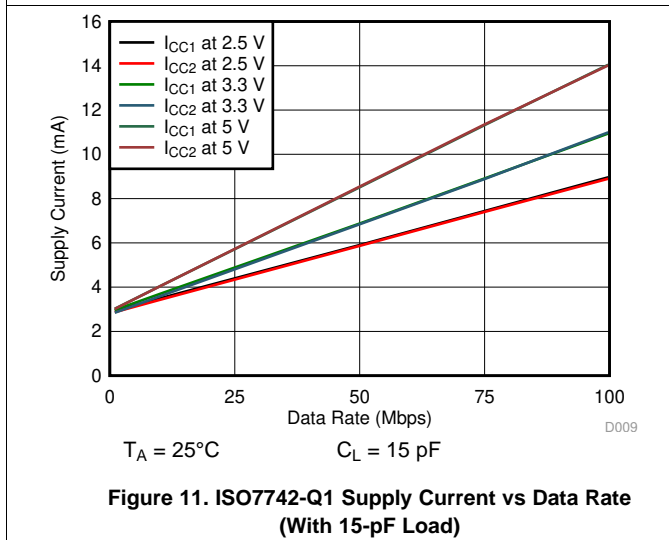
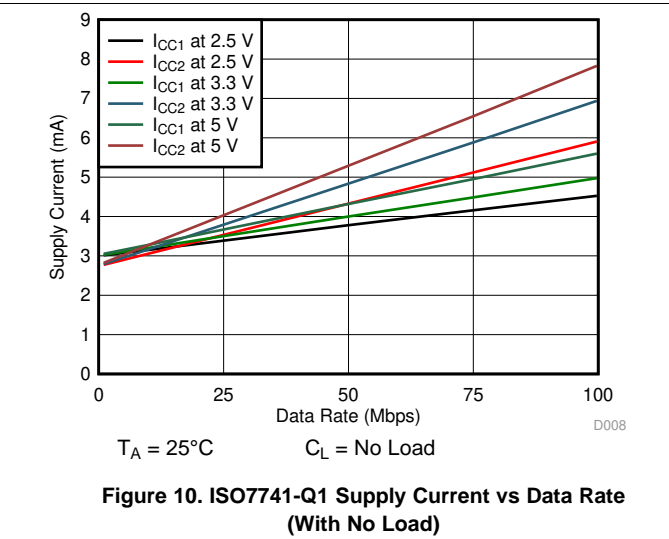
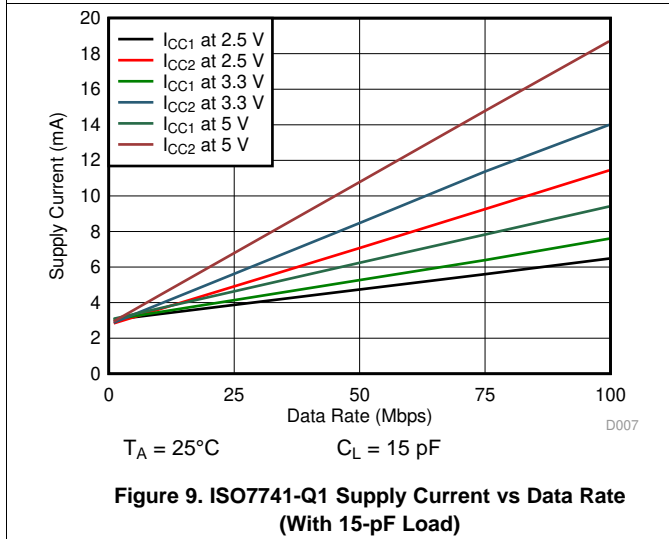
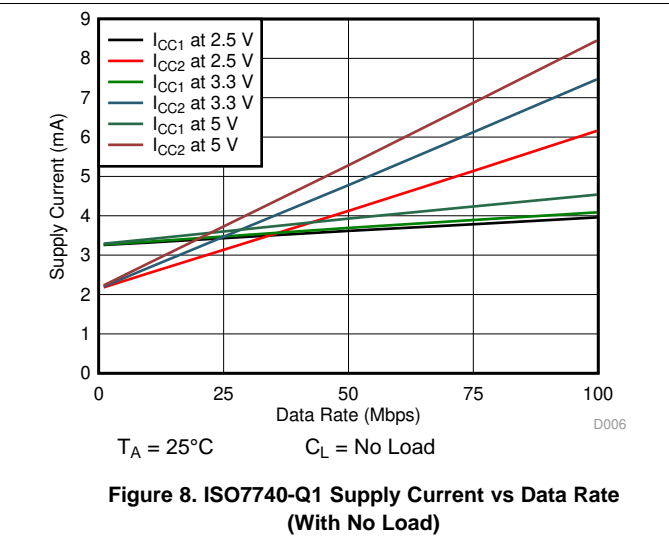
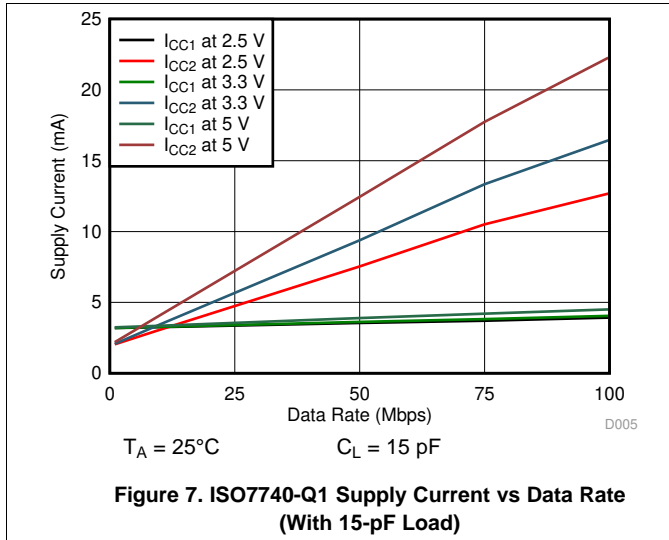

Typical Characteristics (continued)

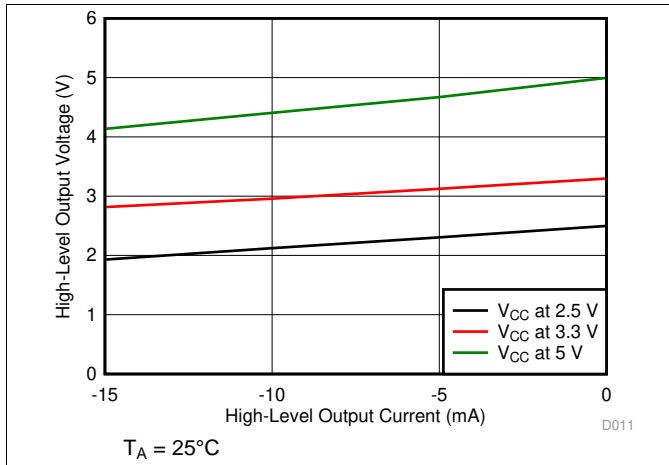

Figure 13. High-Level Output Voltage vs High-level Output Current

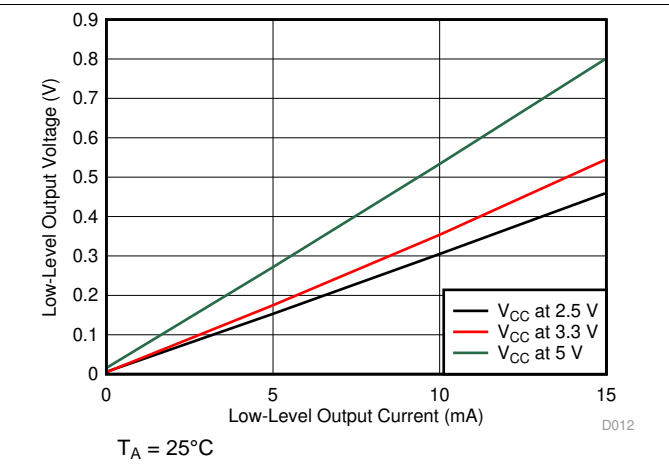

Figure 14. Low-Level Output Voltage vs Low-Level Output Current

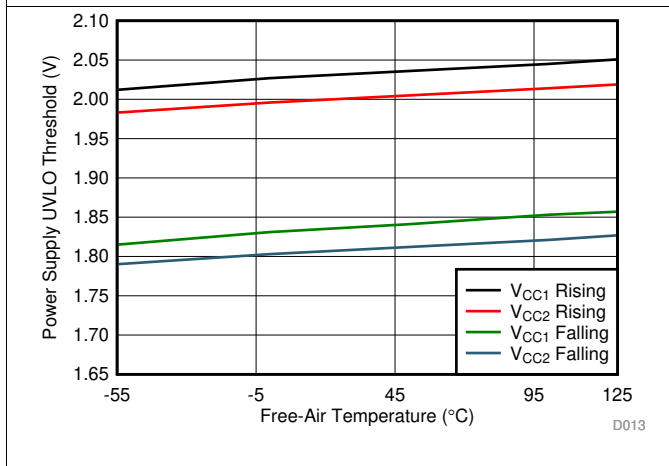

Figure 15. Power Supply Undervoltage Threshold vs Free-Air Temperature

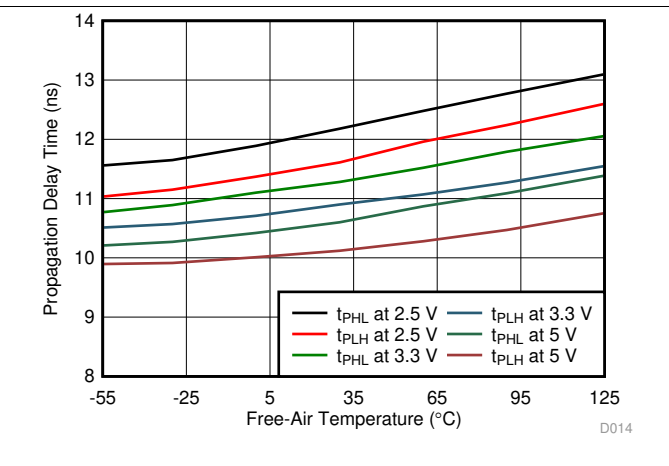
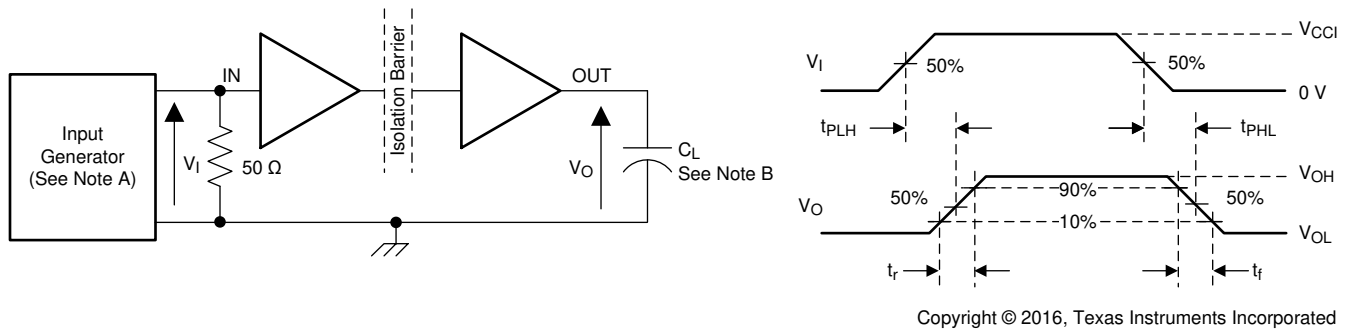

Figure 16. Propagation Delay Time vs Free-Air Temperature

8 Parameter Measurement Information



- A. The input pulse is supplied by a generator having the following characteristics: PRR \leq 50 kHz, 50% duty cycle, $t_r \leq$ 3 ns, $t_f \leq$ 3 ns, $Z_O = 50 \Omega$. At the input, 50Ω resistor is required to terminate Input Generator signal. It is not needed in actual application.
- B. $C_L = 15$ pF and includes instrumentation and fixture capacitance within $\pm 20\%$.

Figure 17. Switching Characteristics Test Circuit and Voltage Waveforms

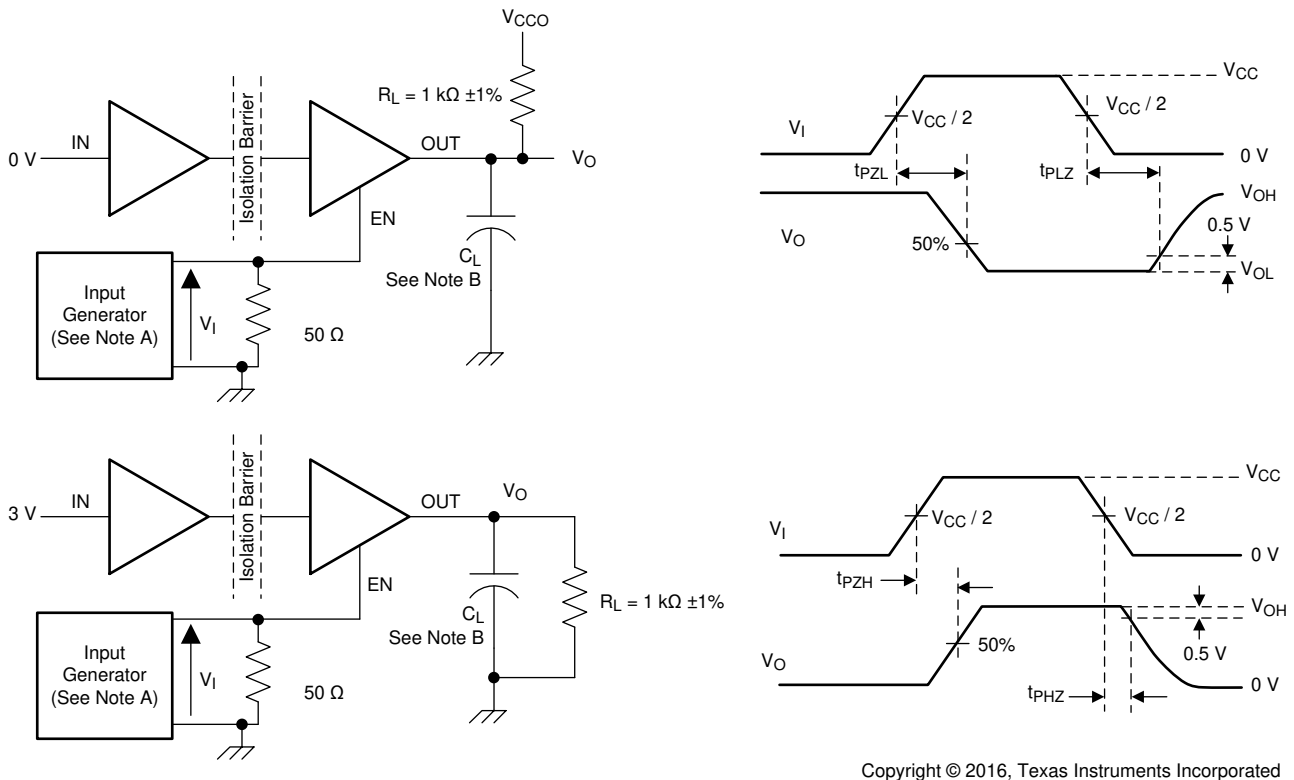

- A. The input pulse is supplied by a generator having the following characteristics: PRR \leq 10 kHz, 50% duty cycle, $t_r \leq$ 3 ns, $t_f \leq$ 3 ns, $Z_O = 50 \Omega$.
- B. $C_L = 15$ pF and includes instrumentation and fixture capacitance within $\pm 20\%$.

Figure 18. Enable/Disable Propagation Delay Time Test Circuit and Waveform

Parameter Measurement Information (continued)

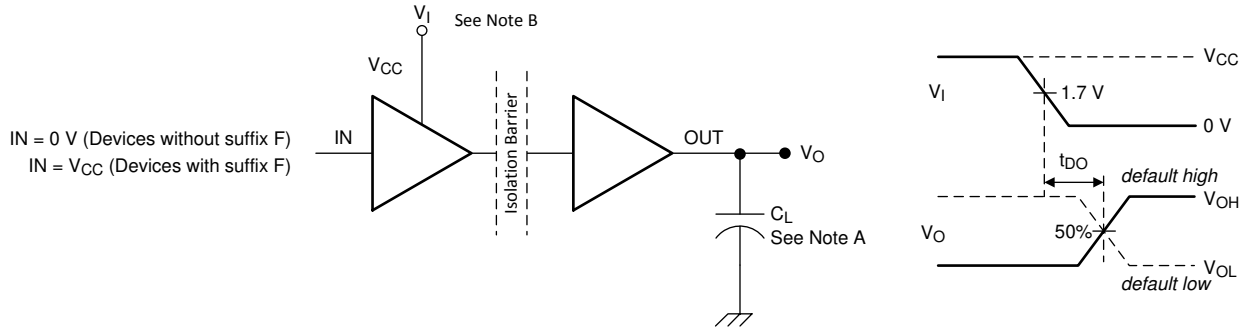

- A. C_L = 15 pF and includes instrumentation and fixture capacitance within ±20%.
- B. Power Supply Ramp Rate = 10 mV/ns

Figure 19. Default Output Delay Time Test Circuit and Voltage Waveforms

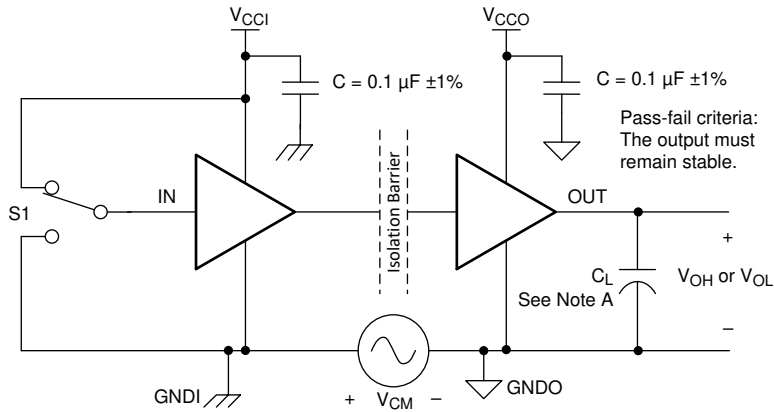

- A. C_L = 15 pF and includes instrumentation and fixture capacitance within ±20%.

Figure 20. Common-Mode Transient Immunity Test Circuit

9 Detailed Description

9.1 Overview

The ISO774x-Q1 family of devices uses an ON-OFF keying (OOK) modulation scheme to transmit the digital data across a silicon dioxide based isolation barrier. The transmitter sends a high frequency carrier across the barrier to represent one digital state and sends no signal to represent the other digital state. The receiver demodulates the signal after advanced signal conditioning and produces the output through a buffer stage. If the ENx pin is low then the output goes to high impedance. The ISO774x-Q1 devices also incorporate advanced circuit techniques to maximize the CMTI performance and minimize the radiated emissions due to the high frequency carrier and IO buffer switching. The conceptual block diagram of a digital capacitive isolator, [Figure 21](#), shows a functional block diagram of a typical channel.

9.2 Functional Block Diagram

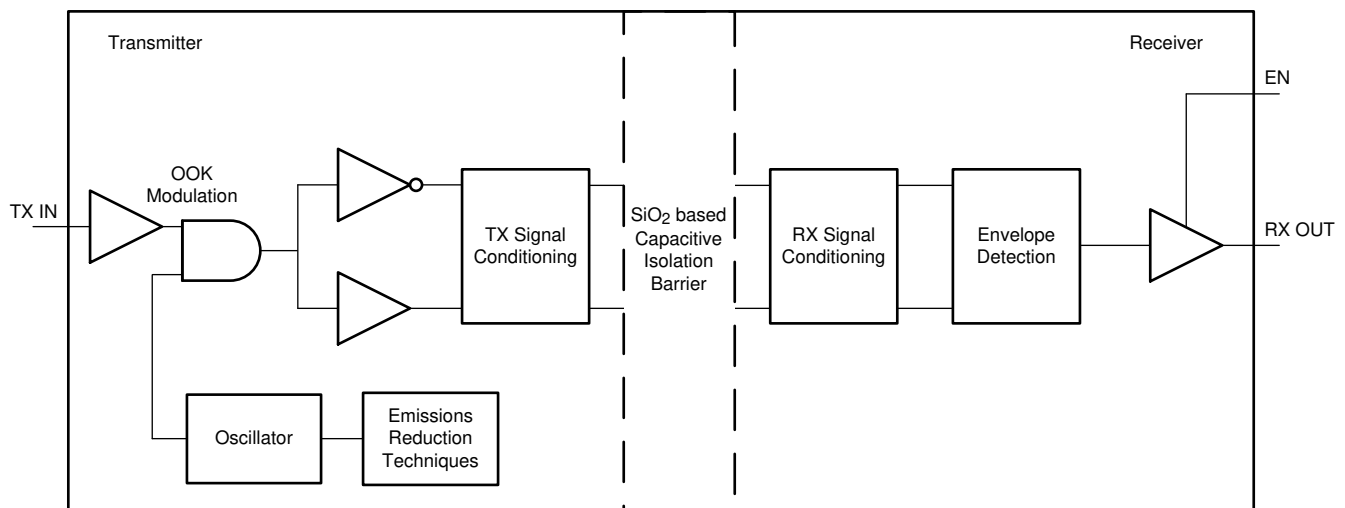

Copyright © 2016, Texas Instruments Incorporated

Figure 21. Conceptual Block Diagram of a Digital Capacitive Isolator

[Figure 22](#) shows a conceptual detail of how the ON-OFF keying scheme works.

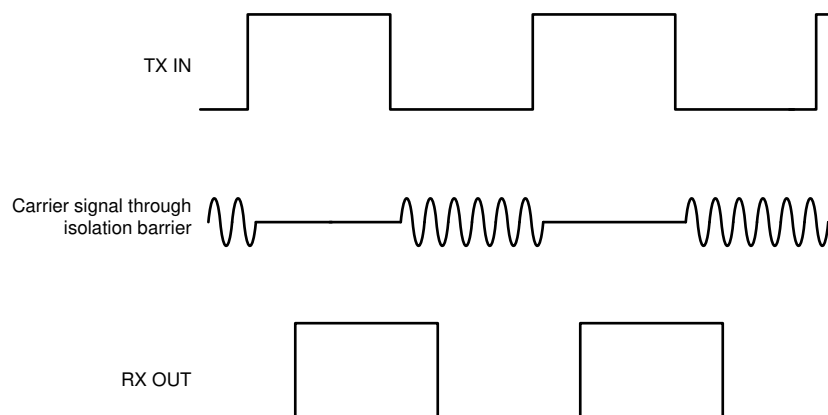

Figure 22. On-Off Keying (OOK) Based Modulation Scheme

9.3 Feature Description

Table 1 provides an overview of the device features.

Table 1. Device Features

PART NUMBER	CHANNEL DIRECTION	MAXIMUM DATA RATE	DEFAULT OUTPUT	PACKAGE	RATED ISOLATION ⁽¹⁾
ISO7740-Q1	4 Forward, 0 Reverse	100 Mbps	High	DW-16	5000 V _{RMS} / 8000 V _{PK}
				DBQ-16	3000 V _{RMS} / 4242 V _{PK}
ISO7740-Q1 with F suffix	4 Forward, 0 Reverse	100 Mbps	Low	DW-16	5000 V _{RMS} / 8000 V _{PK}
				DBQ-16	3000 V _{RMS} / 4242 V _{PK}
ISO7741-Q1	3 Forward, 1 Reverse	100 Mbps	High	DWW-16	5700 V _{RMS} / 8000 V _{PK}
				DW-16	5000 V _{RMS} / 8000 V _{PK}
				DBQ-16	3000 V _{RMS} / 4242 V _{PK}
ISO7741-Q1 with F suffix	3 Forward, 1 Reverse	100 Mbps	Low	DWW-16	5700 V _{RMS} / 8000 V _{PK}
				DW-16	5000 V _{RMS} / 8000 V _{PK}
				DBQ-16	3000 V _{RMS} / 4242 V _{PK}
ISO7742-Q1	2 Forward, 2 Reverse	100 Mbps	High	DW-16	5000 V _{RMS} / 8000 V _{PK}
				DBQ-16	3000 V _{RMS} / 4242 V _{PK}
ISO7742-Q1 with F suffix	2 Forward, 2 Reverse	100 Mbps	Low	DW-16	5000 V _{RMS} / 8000 V _{PK}
				DBQ-16	3000 V _{RMS} / 4242 V _{PK}

(1) See [Safety-Related Certifications](#) for detailed isolation ratings.

9.3.1 Electromagnetic Compatibility (EMC) Considerations

Many applications in harsh industrial environment are sensitive to disturbances such as electrostatic discharge (ESD), electrical fast transient (EFT), surge and electromagnetic emissions. These electromagnetic disturbances are regulated by international standards such as IEC 61000-4-x and CISPR 22. Although system-level performance and reliability depends, to a large extent, on the application board design and layout, the ISO774x-Q1 family of devices incorporates many chip-level design improvements for overall system robustness. Some of these improvements include:

- Robust ESD protection cells for input and output signal pins and inter-chip bond pads.
- Low-resistance connectivity of ESD cells to supply and ground pins.
- Enhanced performance of high voltage isolation capacitor for better tolerance of ESD, EFT and surge events.
- Bigger on-chip decoupling capacitors to bypass undesirable high energy signals through a low impedance path.
- PMOS and NMOS devices isolated from each other by using guard rings to avoid triggering of parasitic SCRs.
- Reduced common mode currents across the isolation barrier by ensuring purely differential internal operation.

9.4 Device Functional Modes

Table 2 lists the functional modes for the ISO774x-Q1 devices.

Table 2. Function Table⁽¹⁾

V_{CCI}	V_{CCO}	INPUT (INx) ⁽²⁾	OUTPUT ENABLE (ENx)	OUTPUT (OUTx)	COMMENTS
PU	PU	H	H or open	H	Normal Operation: A channel output assumes the logic state of its input.
		L	H or open	L	
		Open	H or open	Default	Default mode: When INx is open, the corresponding channel output goes to its default logic state. Default is <i>High</i> for ISO774x-Q1 and <i>Low</i> for ISO774x-Q1 with F suffix.
X	PU	X	L	Z	A low value of output enable causes the outputs to be high-impedance.
PD	PU	X	H or open	Default	Default mode: When V_{CCI} is unpowered, a channel output assumes the logic state based on the selected default option. Default is <i>High</i> for ISO774x-Q1 and <i>Low</i> for ISO774x-Q1 with F suffix. When V_{CCI} transitions from unpowered to powered-up, a channel output assumes the logic state of the input. When V_{CCI} transitions from powered-up to unpowered, channel output assumes the selected default state.
X	PD	X	X	Undetermined	When V_{CCO} is unpowered, a channel output is undetermined ⁽³⁾ . When V_{CCO} transitions from unpowered to powered-up, a channel output assumes the logic state of the input.

- (1) V_{CCI} = Input-side V_{CC} ; V_{CCO} = Output-side V_{CC} ; PU = Powered up ($V_{CC} \geq 2.25$ V); PD = Powered down ($V_{CC} \leq 1.7$ V); X = Irrelevant; H = High level; L = Low level; Z = High Impedance
 (2) A strongly driven input signal can weakly power the floating V_{CC} through an internal protection diode and cause undetermined output.
 (3) The outputs are in undetermined state when 1.7 V < V_{CCI} , V_{CCO} < 2.25 V.

9.4.1 Device I/O Schematics

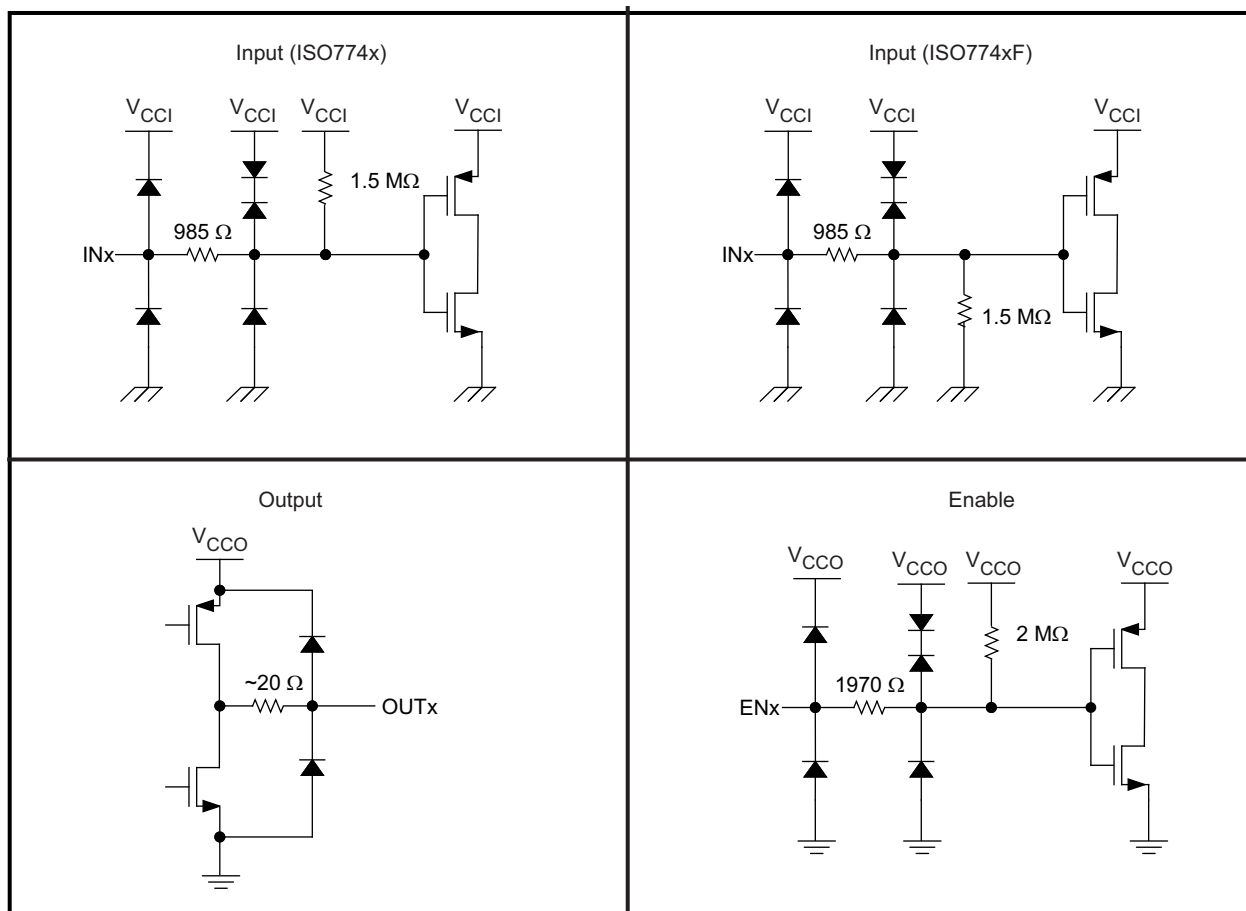

Copyright © 2016, Texas Instruments Incorporated

Figure 23. Device I/O Schematics

10 Application and Implementation

NOTE

Information in the following applications sections is not part of the TI component specification, and TI does not warrant its accuracy or completeness. TI's customers are responsible for determining suitability of components for their purposes. Customers should validate and test their design implementation to confirm system functionality.

10.1 Application Information

The ISO774x-Q1 devices are high-performance, quad-channel digital isolators. These devices come with enable pins on each side which can be used to put the respective outputs in high impedance for multi master driving applications and reduce power consumption. The ISO774x-Q1 devices use single-ended CMOS-logic switching technology. The voltage range is from 2.25 V to 5.5 V for both supplies, V_{CC1} and V_{CC2} . When designing with digital isolators, keep in mind that because of the single-ended design structure, digital isolators do not conform to any specific interface standard and are only intended for isolating single-ended CMOS or TTL digital signal lines. The isolator is typically placed between the data controller (that is, μ C or UART), and a data converter or a line transceiver, regardless of the interface type or standard.

10.2 Typical Application

Figure 24 shows the typical isolated CAN interface implementation.

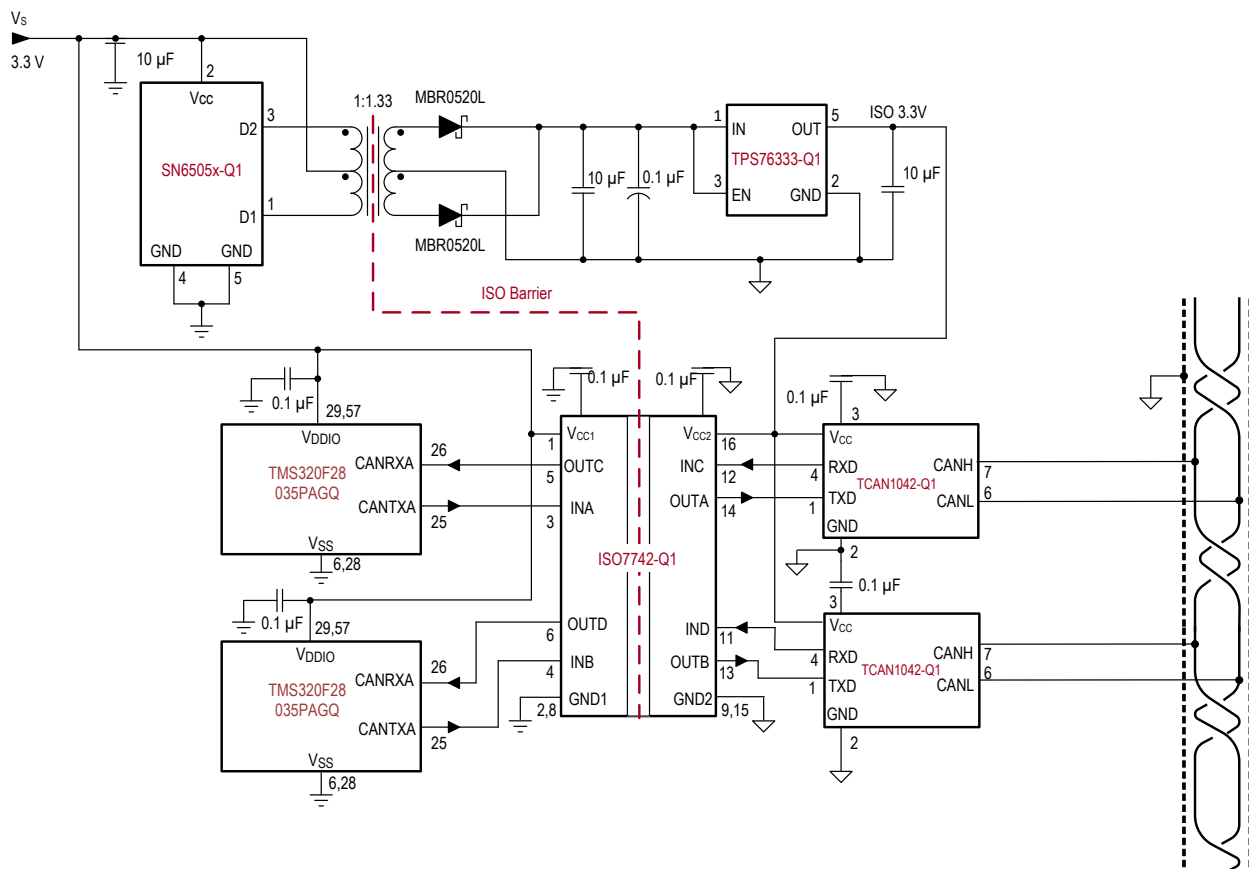

Copyright © 2020, Texas Instruments Incorporated

Figure 24. Typical Isolated CAN Application Circuit

Typical Application (continued)

10.2.1 Design Requirements

To design with these devices, use the parameters listed in [Table 3](#).

Table 3. Design Parameters

PARAMETER	VALUE
Supply voltage, V_{CC1} and V_{CC2}	2.25 to 5.5 V
Decoupling capacitor between V_{CC1} and GND1	0.1 μ F
Decoupling capacitor from V_{CC2} and GND2	0.1 μ F

10.2.2 Detailed Design Procedure

Unlike optocouplers, which require external components to improve performance, provide bias, or limit current, the ISO774x-Q1 family of devices only require two external bypass capacitors to operate.

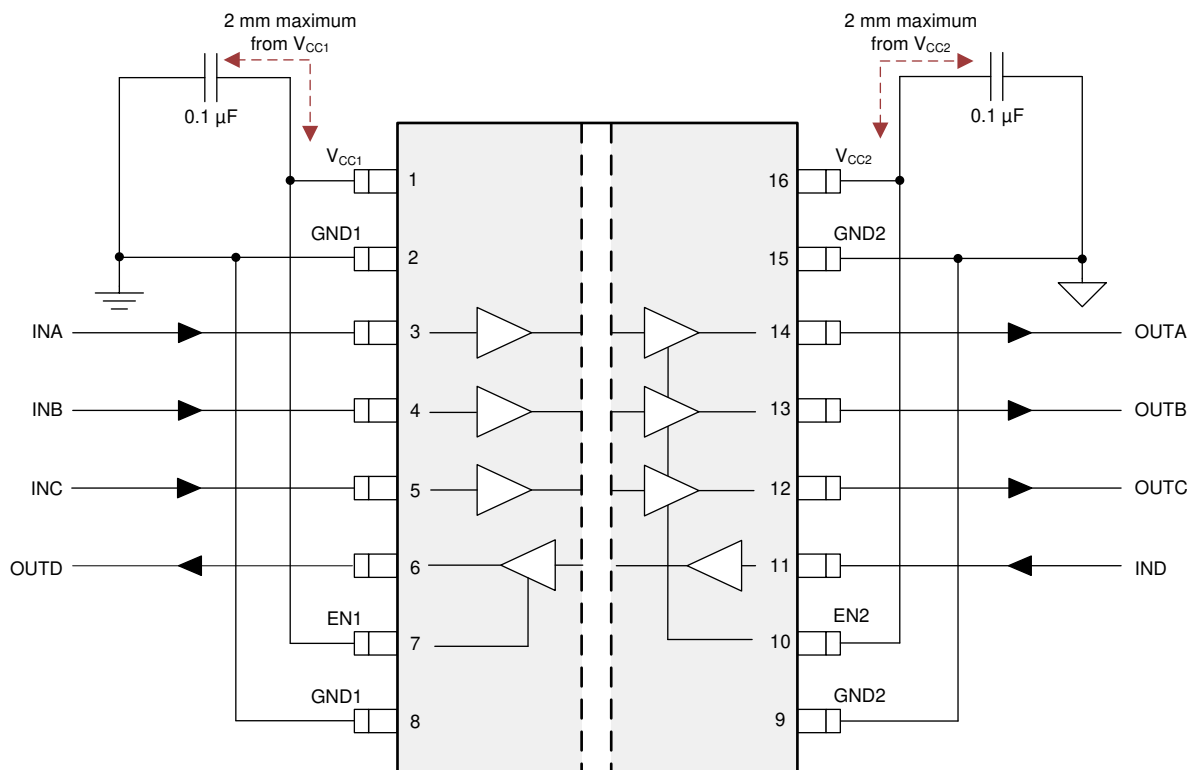
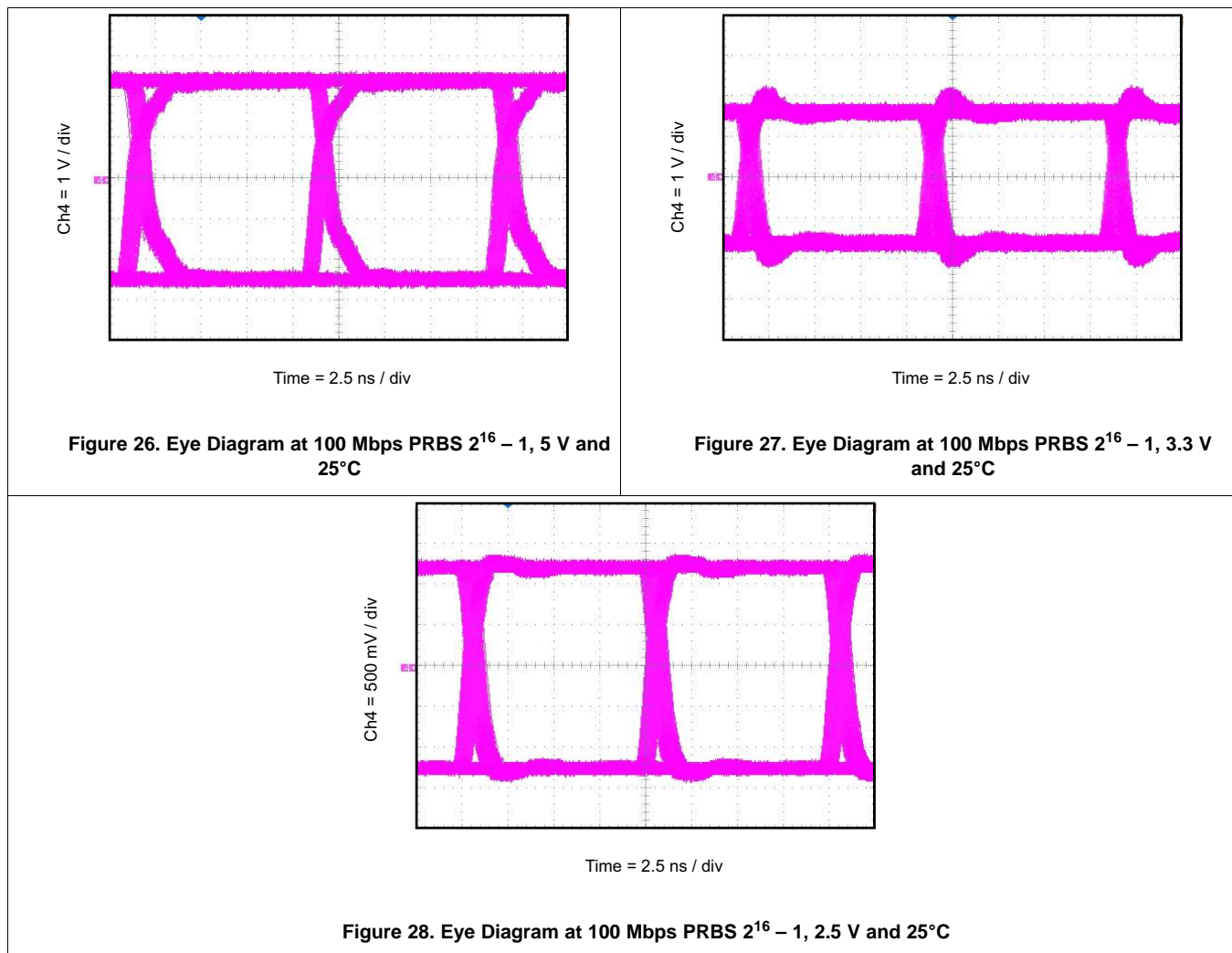

Figure 25. Typical ISO774x-Q1 Circuit Hook-up

The DWW package provides wider creepage and clearance without the need for two isolators in series or an extra isolated power supply, saving design cost and board space. For more details, please refer to the technical document [How to Meet the Higher Isolation Creepage & Clearance Needs in Automotive Applications](#).

10.2.3 Application Curve

The following typical eye diagrams of the ISO774x-Q1 family of devices indicates low jitter and wide open eye at the maximum data rate of 100 Mbps.



10.2.3.1 Insulation Lifetime

Insulation lifetime projection data is collected by using industry-standard Time Dependent Dielectric Breakdown (TDDB) test method. In this test, all pins on each side of the barrier are tied together creating a two-terminal device and high voltage applied between the two sides; See Figure 29 for TDDB test setup. The insulation breakdown data is collected at various high voltages switching at 60 Hz over temperature. For reinforced insulation, VDE standard requires the use of TDDB projection line with failure rate of less than 1 part per million (ppm). Even though the expected minimum insulation lifetime is 20 years at the specified working isolation voltage, VDE reinforced certification requires additional safety margin of 20% for working voltage and 87.5% for lifetime which translates into minimum required insulation lifetime of 37.5 years at a working voltage that's 20% higher than the specified value.

Figure 30 shows the intrinsic capability of the isolation barrier to withstand high voltage stress over its lifetime. Based on the TDDB data, the insulation withstand capability of DW-16 package is 1500 V_{RMS} with a lifetime of 135 years as illustrated in Figure 30. Similarly, the insulation withstand capability of DWW-16 package is 2000 V_{RMS} with a corresponding lifetime of 34 years. DBQ-16 package at 400 V_{RMS} working voltage has a much longer lifetime than both DW-16 and DWW-16 packages. Factors, such as package size, pollution degree, and material group can limit the working voltage of a component.

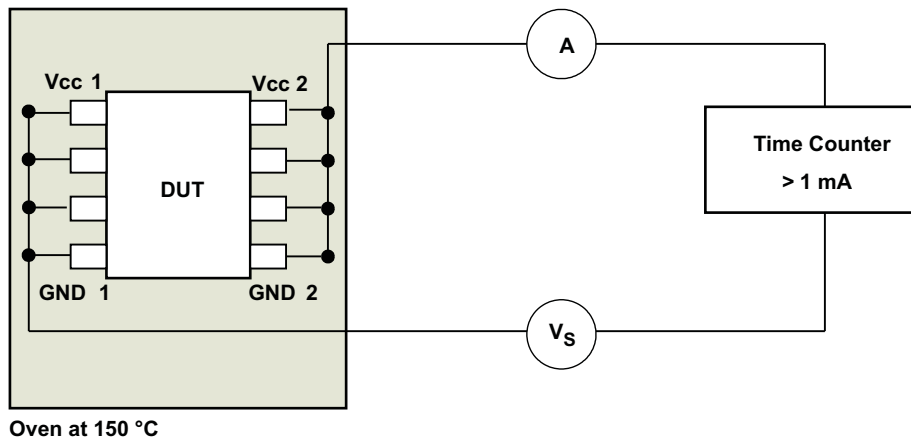

Figure 29. Test Setup for Insulation Lifetime Measurement

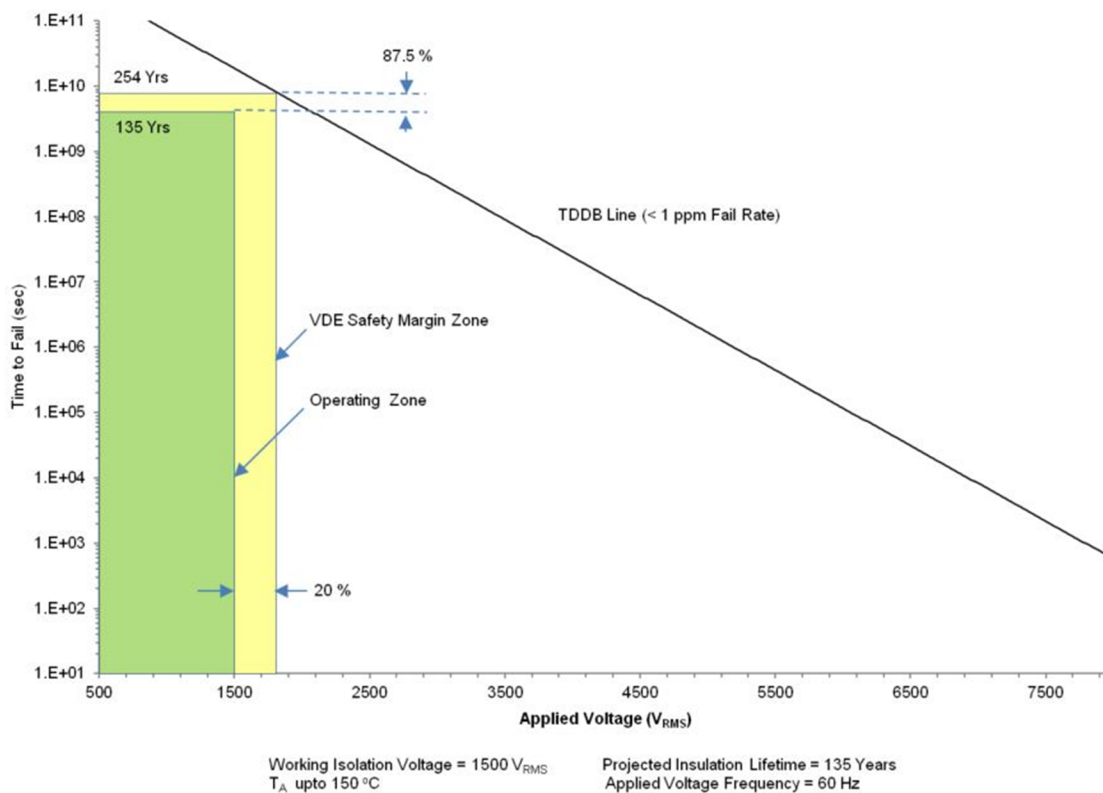

Figure 30. Insulation Lifetime Projection Data

11 Power Supply Recommendations

To help ensure reliable operation at data rates and supply voltages, a 0.1- μ F bypass capacitor is recommended at the input and output supply pins (V_{CC1} and V_{CC2}). The capacitors should be placed as close to the supply pins as possible. If only a single primary-side power supply is available in an application, isolated power can be generated for the secondary-side with the help of a transformer driver such as Texas Instruments' [SN6501-Q1](#) or [SN6505B-Q1](#). For such applications, detailed power supply design and transformer selection recommendations are available in [SN6501-Q1 Transformer Driver for Isolated Power Supplies](#) and [SN6505x-Q1 Low-Noise 1-A Transformer Drivers for Isolated Power Supplies](#) data sheets.

12 Layout

12.1 Layout Guidelines

A minimum of four layers is required to accomplish a low EMI PCB design (see [Figure 31](#)). Layer stacking should be in the following order (top-to-bottom): high-speed signal layer, ground plane, power plane and low-frequency signal layer.

- Routing the high-speed traces on the top layer avoids the use of vias (and the introduction of their inductances) and allows for clean interconnects between the isolator and the transmitter and receiver circuits of the data link.
- Placing a solid ground plane next to the high-speed signal layer establishes controlled impedance for transmission line interconnects and provides an excellent low-inductance path for the return current flow.
- Placing the power plane next to the ground plane creates additional high-frequency bypass capacitance of approximately 100 pF/inch².
- Routing the slower speed control signals on the bottom layer allows for greater flexibility as these signal links usually have margin to tolerate discontinuities such as vias.

If an additional supply voltage plane or signal layer is needed, add a second power or ground plane system to the stack to keep it symmetrical. This makes the stack mechanically stable and prevents it from warping. Also the power and ground plane of each power system can be placed closer together, thus increasing the high-frequency bypass capacitance significantly.

For detailed layout recommendations, refer to the [Digital Isolator Design Guide](#).

12.1.1 PCB Material

For digital circuit boards operating below 150 Mbps, (or rise and fall times higher than 1 ns), and trace lengths of up to 10 inches, use standard FR-4 UL94V-0 printed circuit boards. This PCB is preferred over cheaper alternatives due to its lower dielectric losses at high frequencies, less moisture absorption, greater strength and stiffness, and self-extinguishing flammability-characteristics.

12.2 Layout Example

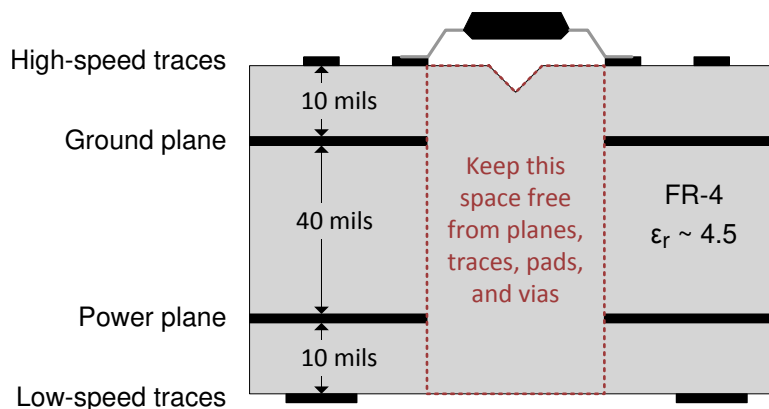

Figure 31. Layout Example Schematic

13 Device and Documentation Support

13.1 Documentation Support

13.1.1 Related Documentation

For related documentation, see the following:

- Texas Instruments, [Digital Isolator Design Guide](#)
- Texas Instruments, [Isolation Glossary](#)
- Texas Instruments, [How to use isolation to improve ESD, EFT, and Surge immunity in industrial systems application report](#)
- Texas Instruments, [SN6501-Q1 Transformer Driver for Isolated Power Supplies data sheet](#)
- Texas Instruments, [SN6505x-Q1 Low-Noise 1-A Transformer Drivers for Isolated Power Supplies data sheet](#)
- Texas Instruments, [TCAN1042-Q1 Automotive fault protected CAN transceiver with CAN FD data sheet](#)
- Texas Instruments, [TMS320F28035 Piccolo™ Microcontrollers data sheet](#)
- Texas Instruments, [TPS76333-Q1 Low-Power 150-mA Low-Dropout Linear Regulators data sheet](#)

13.2 Related Links

The table below lists quick access links. Categories include technical documents, support and community resources, tools and software, and quick access to sample or buy.

Table 4. Related Links

PARTS	PRODUCT FOLDER	ORDER NOW	TECHNICAL DOCUMENTS	TOOLS & SOFTWARE	SUPPORT & COMMUNITY
ISO7740-Q1	Click here	Click here	Click here	Click here	Click here
ISO7741-Q1	Click here	Click here	Click here	Click here	Click here
ISO7742-Q1	Click here	Click here	Click here	Click here	Click here

13.3 Receiving Notification of Documentation Updates

To receive notification of documentation updates, navigate to the device product folder on ti.com. In the upper right corner, click on *Alert me* to register and receive a weekly digest of any product information that has changed. For change details, review the revision history included in any revised document.

13.4 Community Resources

[TI E2E™ support forums](#) are an engineer's go-to source for fast, verified answers and design help — straight from the experts. Search existing answers or ask your own question to get the quick design help you need.

Linked content is provided "AS IS" by the respective contributors. They do not constitute TI specifications and do not necessarily reflect TI's views; see TI's [Terms of Use](#).

13.5 Trademarks

Piccolo, E2E are trademarks of Texas Instruments. All other trademarks are the property of their respective owners.

13.6 Electrostatic Discharge Caution



This integrated circuit can be damaged by ESD. Texas Instruments recommends that all integrated circuits be handled with appropriate precautions. Failure to observe proper handling and installation procedures can cause damage.

ESD damage can range from subtle performance degradation to complete device failure. Precision integrated circuits may be more susceptible to damage because very small parametric changes could cause the device not to meet its published specifications.

13.7 Glossary

[SLYZ022](#) — *TI Glossary*.

This glossary lists and explains terms, acronyms, and definitions.

14 Mechanical, Packaging, and Orderable Information

The following pages include mechanical packaging and orderable information. This information is the most current data available for the designated devices. This data is subject to change without notice and revision of this document. For browser-based versions of this data sheet, refer to the left-hand navigation.

PACKAGING INFORMATION

Orderable Device	Status (1)	Package Type	Package Drawing	Pins	Package Qty	Eco Plan (2)	Lead/Ball Finish (6)	MSL Peak Temp (3)	Op Temp (°C)	Device Marking (4/5)	Samples
ISO7740FQDBQQ1	ACTIVE	SSOP	DBQ	16	75	Green (RoHS & no Sb/Br)	NIPDAU	Level-2-260C-1 YEAR	-40 to 125	7740FQ	Samples
ISO7740FQDBQRQ1	ACTIVE	SSOP	DBQ	16	2500	Green (RoHS & no Sb/Br)	NIPDAU	Level-2-260C-1 YEAR	-40 to 125	7740FQ	Samples
ISO7740FQDWQ1	ACTIVE	SOIC	DW	16	40	Green (RoHS & no Sb/Br)	NIPDAU	Level-2-260C-1 YEAR	-40 to 125	ISO7740FQ	Samples
ISO7740FQDWRQ1	ACTIVE	SOIC	DW	16	2000	Green (RoHS & no Sb/Br)	NIPDAU	Level-2-260C-1 YEAR	-40 to 125	ISO7740FQ	Samples
ISO7740QDBQQ1	ACTIVE	SSOP	DBQ	16	75	Green (RoHS & no Sb/Br)	NIPDAU	Level-2-260C-1 YEAR	-40 to 125	7740Q	Samples
ISO7740QDBQRQ1	ACTIVE	SSOP	DBQ	16	2500	Green (RoHS & no Sb/Br)	NIPDAU	Level-2-260C-1 YEAR	-40 to 125	7740Q	Samples
ISO7740QDWQ1	ACTIVE	SOIC	DW	16	40	Green (RoHS & no Sb/Br)	NIPDAU	Level-2-260C-1 YEAR	-40 to 125	ISO7740Q	Samples
ISO7740QDWRQ1	ACTIVE	SOIC	DW	16	2000	Green (RoHS & no Sb/Br)	NIPDAU	Level-2-260C-1 YEAR	-40 to 125	ISO7740Q	Samples
ISO7741FQDBQQ1	ACTIVE	SSOP	DBQ	16	75	Green (RoHS & no Sb/Br)	NIPDAU	Level-2-260C-1 YEAR	-40 to 125	7741FQ	Samples
ISO7741FQDBQRQ1	ACTIVE	SSOP	DBQ	16	2500	Green (RoHS & no Sb/Br)	NIPDAU	Level-2-260C-1 YEAR	-40 to 125	7741FQ	Samples
ISO7741FQDWQ1	ACTIVE	SOIC	DW	16	40	Green (RoHS & no Sb/Br)	NIPDAU	Level-2-260C-1 YEAR	-40 to 125	ISO7741FQ	Samples
ISO7741FQDWRQ1	ACTIVE	SOIC	DW	16	2000	Green (RoHS & no Sb/Br)	NIPDAU	Level-2-260C-1 YEAR	-40 to 125	ISO7741FQ	Samples
ISO7741FQDWWQ1	ACTIVE	SOIC	DWW	16	45	Green (RoHS & no Sb/Br)	NIPDAU	Level-2-260C-1 YEAR	-40 to 125	ISO7741FQ	Samples
ISO7741FQDWRQ1	ACTIVE	SOIC	DWW	16	1000	Green (RoHS & no Sb/Br)	NIPDAU	Level-2-260C-1 YEAR	-40 to 125	ISO7741FQ	Samples
ISO7741QDBQQ1	ACTIVE	SSOP	DBQ	16	75	Green (RoHS & no Sb/Br)	NIPDAU	Level-2-260C-1 YEAR	-40 to 125	7741Q	Samples
ISO7741QDBQRQ1	ACTIVE	SSOP	DBQ	16	2500	Green (RoHS & no Sb/Br)	NIPDAU	Level-2-260C-1 YEAR	-40 to 125	7741Q	Samples
ISO7741QDWQ1	ACTIVE	SOIC	DW	16	40	Green (RoHS & no Sb/Br)	NIPDAU	Level-2-260C-1 YEAR	-40 to 125	ISO7741Q	Samples

Orderable Device	Status (1)	Package Type	Package Drawing	Pins	Package Qty	Eco Plan (2)	Lead/Ball Finish (6)	MSL Peak Temp (3)	Op Temp (°C)	Device Marking (4/5)	Samples
ISO7741QDWRQ1	ACTIVE	SOIC	DW	16	2000	Green (RoHS & no Sb/Br)	NIPDAU	Level-2-260C-1 YEAR	-40 to 125	ISO7741Q	Samples
ISO7741QDWWQ1	ACTIVE	SOIC	DWW	16	45	Green (RoHS & no Sb/Br)	NIPDAU	Level-2-260C-1 YEAR	-40 to 125	ISO7741Q	Samples
ISO7741QDWWRQ1	ACTIVE	SOIC	DWW	16	1000	Green (RoHS & no Sb/Br)	NIPDAU	Level-2-260C-1 YEAR	-40 to 125	ISO7741Q	Samples
ISO7742FQDBQQ1	ACTIVE	SSOP	DBQ	16	75	Green (RoHS & no Sb/Br)	NIPDAU	Level-2-260C-1 YEAR	-40 to 125	7742FQ	Samples
ISO7742FQDBQRQ1	ACTIVE	SSOP	DBQ	16	2500	Green (RoHS & no Sb/Br)	NIPDAU	Level-2-260C-1 YEAR	-40 to 125	7742FQ	Samples
ISO7742FQDWQ1	ACTIVE	SOIC	DW	16	40	Green (RoHS & no Sb/Br)	NIPDAU	Level-2-260C-1 YEAR	-40 to 125	ISO7742FQ	Samples
ISO7742FQDWRQ1	ACTIVE	SOIC	DW	16	2000	Green (RoHS & no Sb/Br)	NIPDAU	Level-2-260C-1 YEAR	-40 to 125	ISO7742FQ	Samples
ISO7742QBQQ1	ACTIVE	SSOP	DBQ	16	75	Green (RoHS & no Sb/Br)	NIPDAU	Level-2-260C-1 YEAR	-40 to 125	7742Q	Samples
ISO7742QDBQRQ1	ACTIVE	SSOP	DBQ	16	2500	Green (RoHS & no Sb/Br)	NIPDAU	Level-2-260C-1 YEAR	-40 to 125	7742Q	Samples
ISO7742QDWQ1	ACTIVE	SOIC	DW	16	40	Green (RoHS & no Sb/Br)	NIPDAU	Level-2-260C-1 YEAR	-40 to 125	ISO7742Q	Samples
ISO7742QDWRQ1	ACTIVE	SOIC	DW	16	2000	Green (RoHS & no Sb/Br)	NIPDAU	Level-2-260C-1 YEAR	-40 to 125	ISO7742Q	Samples

(1) The marketing status values are defined as follows:

ACTIVE: Product device recommended for new designs.

LIFEBUY: TI has announced that the device will be discontinued, and a lifetime-buy period is in effect.

NRND: Not recommended for new designs. Device is in production to support existing customers, but TI does not recommend using this part in a new design.

PREVIEW: Device has been announced but is not in production. Samples may or may not be available.

OBSOLETE: TI has discontinued the production of the device.

(2) **RoHS:** TI defines "RoHS" to mean semiconductor products that are compliant with the current EU RoHS requirements for all 10 RoHS substances, including the requirement that RoHS substance do not exceed 0.1% by weight in homogeneous materials. Where designed to be soldered at high temperatures, "RoHS" products are suitable for use in specified lead-free processes. TI may reference these types of products as "Pb-Free".

RoHS Exempt: TI defines "RoHS Exempt" to mean products that contain lead but are compliant with EU RoHS pursuant to a specific EU RoHS exemption.

Green: TI defines "Green" to mean the content of Chlorine (Cl) and Bromine (Br) based flame retardants meet JS709B low halogen requirements of <=1000ppm threshold. Antimony trioxide based flame retardants must also meet the <=1000ppm threshold requirement.

(3) MSL, Peak Temp. - The Moisture Sensitivity Level rating according to the JEDEC industry standard classifications, and peak solder temperature.

(4) There may be additional marking, which relates to the logo, the lot trace code information, or the environmental category on the device.

(5) Multiple Device Markings will be inside parentheses. Only one Device Marking contained in parentheses and separated by a "~" will appear on a device. If a line is indented then it is a continuation of the previous line and the two combined represent the entire Device Marking for that device.

(6) Lead/Ball Finish - Orderable Devices may have multiple material finish options. Finish options are separated by a vertical ruled line. Lead/Ball Finish values may wrap to two lines if the finish value exceeds the maximum column width.

Important Information and Disclaimer:The information provided on this page represents TI's knowledge and belief as of the date that it is provided. TI bases its knowledge and belief on information provided by third parties, and makes no representation or warranty as to the accuracy of such information. Efforts are underway to better integrate information from third parties. TI has taken and continues to take reasonable steps to provide representative and accurate information but may not have conducted destructive testing or chemical analysis on incoming materials and chemicals. TI and TI suppliers consider certain information to be proprietary, and thus CAS numbers and other limited information may not be available for release.

In no event shall TI's liability arising out of such information exceed the total purchase price of the TI part(s) at issue in this document sold by TI to Customer on an annual basis.

OTHER QUALIFIED VERSIONS OF ISO7740-Q1, ISO7741-Q1, ISO7742-Q1 :

- Catalog: [ISO7740](#), [ISO7741](#), [ISO7742](#)

NOTE: Qualified Version Definitions:

- Catalog - TI's standard catalog product

TAPE AND REEL INFORMATION



QUADRANT ASSIGNMENTS FOR PIN 1 ORIENTATION IN TAPE



*All dimensions are nominal

Device	Package Type	Package Drawing	Pins	SPQ	Reel Diameter (mm)	Reel Width W1 (mm)	A0 (mm)	B0 (mm)	K0 (mm)	P1 (mm)	W (mm)	Pin1 Quadrant
ISO7740FQDBQRQ1	SSOP	DBQ	16	2500	330.0	12.4	6.4	5.2	2.1	8.0	12.0	Q1
ISO7740FQDWRQ1	SOIC	DW	16	2000	330.0	16.4	10.75	10.7	2.7	12.0	16.0	Q1
ISO7740QDBQRQ1	SSOP	DBQ	16	2500	330.0	12.4	6.4	5.2	2.1	8.0	12.0	Q1
ISO7740QDWRQ1	SOIC	DW	16	2000	330.0	16.4	10.75	10.7	2.7	12.0	16.0	Q1
ISO7741FQDBQRQ1	SSOP	DBQ	16	2500	330.0	12.4	6.4	5.2	2.1	8.0	12.0	Q1
ISO7741FQDWRQ1	SOIC	DW	16	2000	330.0	16.4	10.75	10.7	2.7	12.0	16.0	Q1
ISO7741FQDWRQ1	SOIC	DWW	16	1000	330.0	24.4	18.0	10.0	3.0	20.0	24.0	Q1
ISO7741QDBQRQ1	SSOP	DBQ	16	2500	330.0	12.4	6.4	5.2	2.1	8.0	12.0	Q1
ISO7741QDWRQ1	SOIC	DW	16	2000	330.0	16.4	10.75	10.7	2.7	12.0	16.0	Q1
ISO7741QDWRQ1	SOIC	DWW	16	1000	330.0	24.4	18.0	10.0	3.0	20.0	24.0	Q1
ISO7742FQDBQRQ1	SSOP	DBQ	16	2500	330.0	12.4	6.4	5.2	2.1	8.0	12.0	Q1
ISO7742FQDWRQ1	SOIC	DW	16	2000	330.0	16.4	10.75	10.7	2.7	12.0	16.0	Q1
ISO7742QDBQRQ1	SSOP	DBQ	16	2500	330.0	12.4	6.4	5.2	2.1	8.0	12.0	Q1
ISO7742QDWRQ1	SOIC	DW	16	2000	330.0	16.4	10.75	10.7	2.7	12.0	16.0	Q1

TAPE AND REEL BOX DIMENSIONS

*All dimensions are nominal

Device	Package Type	Package Drawing	Pins	SPQ	Length (mm)	Width (mm)	Height (mm)
ISO7740FQDBQRQ1	SSOP	DBQ	16	2500	350.0	350.0	43.0
ISO7740FQDWRQ1	SOIC	DW	16	2000	350.0	350.0	43.0
ISO7740QDBQRQ1	SSOP	DBQ	16	2500	350.0	350.0	43.0
ISO7740QDWRQ1	SOIC	DW	16	2000	350.0	350.0	43.0
ISO7741FQDBQRQ1	SSOP	DBQ	16	2500	350.0	350.0	43.0
ISO7741FQDWRQ1	SOIC	DW	16	2000	350.0	350.0	43.0
ISO7741FQDWRQ1	SOIC	DWW	16	1000	350.0	350.0	43.0
ISO7741QDBQRQ1	SSOP	DBQ	16	2500	350.0	350.0	43.0
ISO7741QDWRQ1	SOIC	DW	16	2000	350.0	350.0	43.0
ISO7741QDWRQ1	SOIC	DWW	16	1000	350.0	350.0	43.0
ISO7742FQDBQRQ1	SSOP	DBQ	16	2500	350.0	350.0	43.0
ISO7742FQDWRQ1	SOIC	DW	16	2000	350.0	350.0	43.0
ISO7742QDBQRQ1	SSOP	DBQ	16	2500	350.0	350.0	43.0
ISO7742QDWRQ1	SOIC	DW	16	2000	350.0	350.0	43.0

DWW0016A



PACKAGE OUTLINE

SOIC - 2.65 mm max height

PLASTIC SMALL OUTLINE

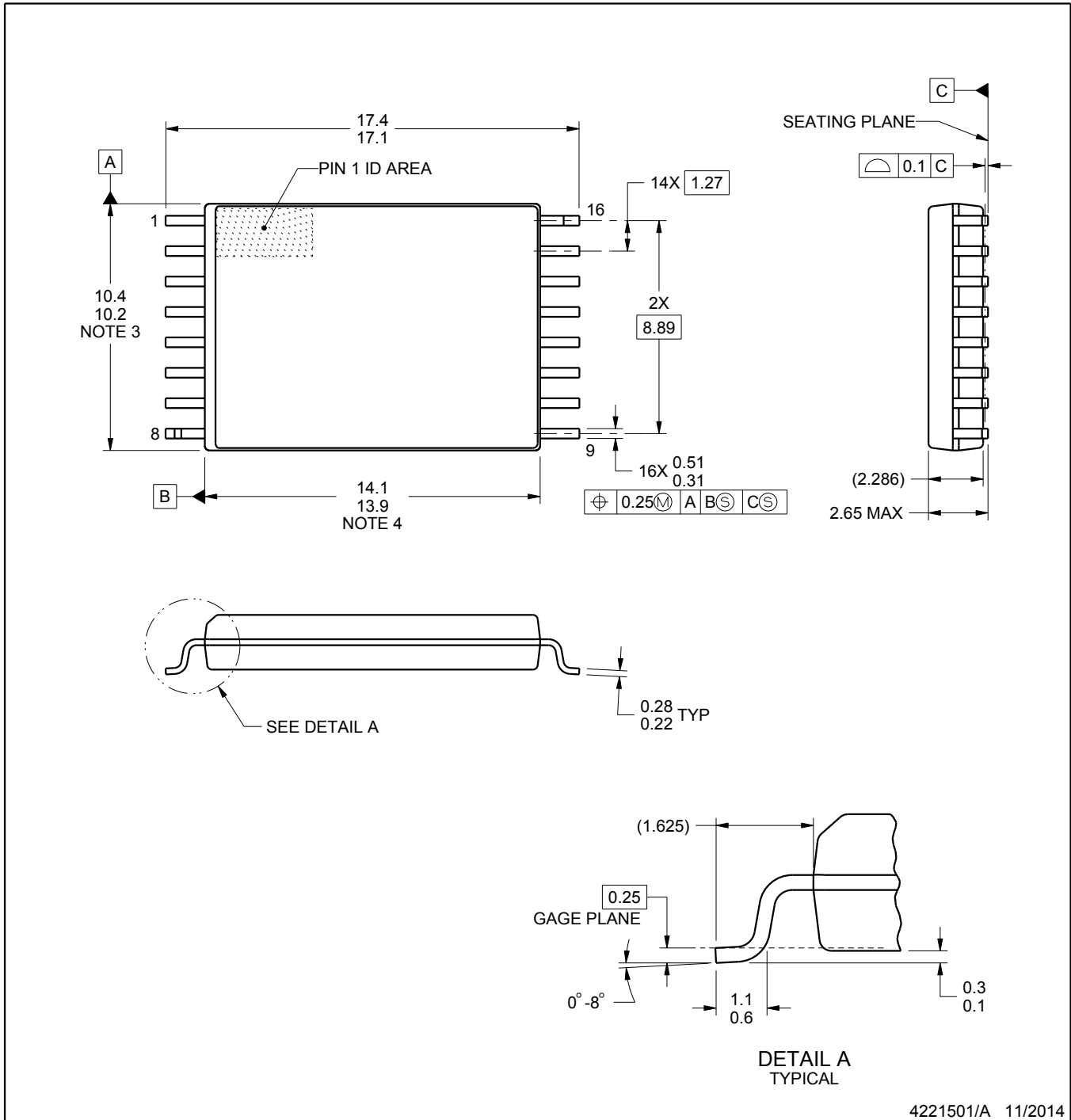

4221501/A 11/2014

NOTES:

1. All linear dimensions are in millimeters. Any dimensions in parenthesis are for reference only. Dimensioning and tolerancing per ASME Y14.5M.
2. This drawing is subject to change without notice.
3. This dimension does not include mold flash, protrusions, or gate burrs. Mold flash, protrusions, or gate burrs shall not exceed 0,15 mm per side.
4. This dimension does not include interlead flash.

EXAMPLE BOARD LAYOUT

DWW0016A

SOIC - 2.65 mm max height

PLASTIC SMALL OUTLINE

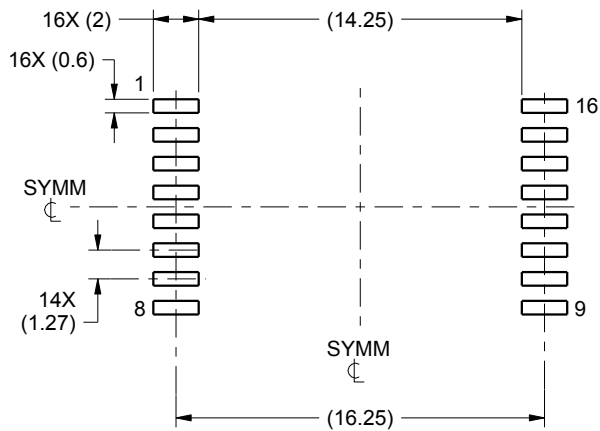

LAND PATTERN EXAMPLE
STANDARD
SCALE:3X

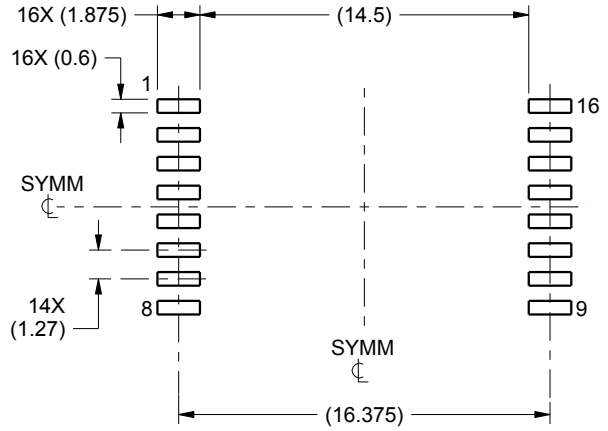

LAND PATTERN EXAMPLE
PCB CLEARANCE & CREEPAGE OPTIMIZED
SCALE:3X

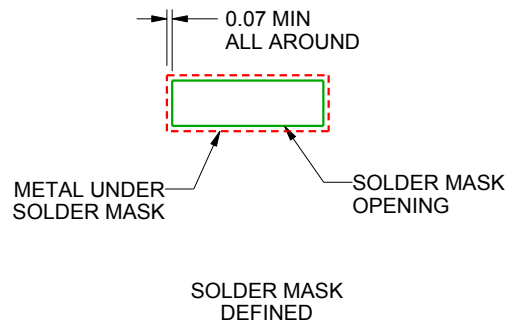
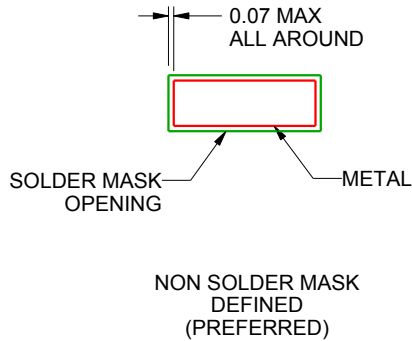

SOLDER MASK DETAILS

4221501/A 11/2014

NOTES: (continued)

5. Publication IPC-7351 may have alternate designs.
6. Solder mask tolerances between and around signal pads can vary based on board fabrication site.

EXAMPLE STENCIL DESIGN

DWW0016A

SOIC - 2.65 mm max height

PLASTIC SMALL OUTLINE

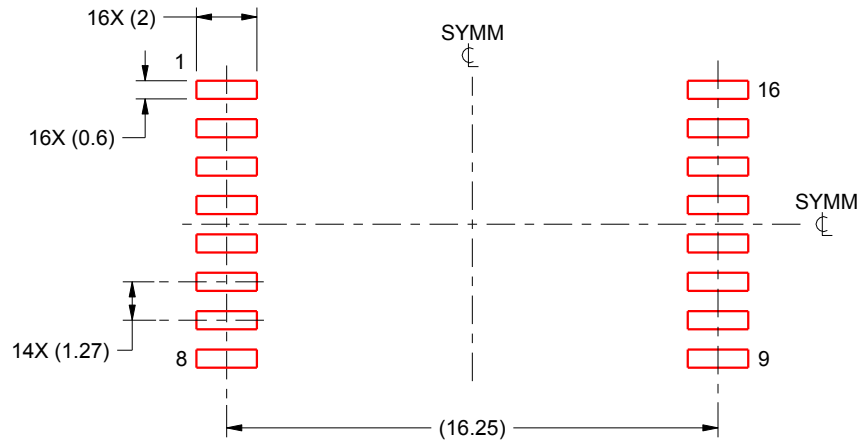

SOLDER PASTE EXAMPLE
STANDARD
BASED ON 0.125 mm THICK STENCIL
SCALE:4X

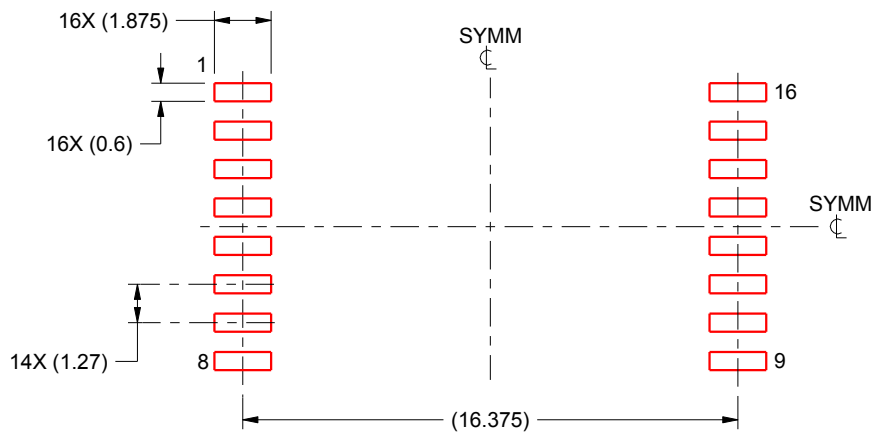

SOLDER PASTE EXAMPLE
PCB CLEARANCE & CREEPAGE OPTIMIZED
BASED ON 0.125 mm THICK STENCIL
SCALE:4X

4221501/A 11/2014

NOTES: (continued)

7. Laser cutting apertures with trapezoidal walls and rounded corners may offer better paste release. IPC-7525 may have alternate design recommendations.
8. Board assembly site may have different recommendations for stencil design.

GENERIC PACKAGE VIEW

DW 16

SOIC - 2.65 mm max height

7.5 x 10.3, 1.27 mm pitch

SMALL OUTLINE INTEGRATED CIRCUIT

This image is a representation of the package family, actual package may vary.
Refer to the product data sheet for package details.



4224780/A



DW0016B

PACKAGE OUTLINE

SOIC - 2.65 mm max height

SOIC



4221009/B 07/2016

NOTES:

1. All linear dimensions are in millimeters. Dimensions in parenthesis are for reference only. Dimensioning and tolerancing per ASME Y14.5M.
2. This drawing is subject to change without notice.
3. This dimension does not include mold flash, protrusions, or gate burrs. Mold flash, protrusions, or gate burrs shall not exceed 0.15 mm, per side.
4. This dimension does not include interlead flash. Interlead flash shall not exceed 0.25 mm, per side.
5. Reference JEDEC registration MS-013.

EXAMPLE BOARD LAYOUT

DW0016B

SOIC - 2.65 mm max height

SOIC



LAND PATTERN EXAMPLE
SCALE:4X



SOLDER MASK DETAILS

4221009/B 07/2016

NOTES: (continued)

- 6. Publication IPC-7351 may have alternate designs.
- 7. Solder mask tolerances between and around signal pads can vary based on board fabrication site.

EXAMPLE STENCIL DESIGN

DW0016B

SOIC - 2.65 mm max height

SOIC



NOTES: (continued)

8. Laser cutting apertures with trapezoidal walls and rounded corners may offer better paste release. IPC-7525 may have alternate design recommendations.
9. Board assembly site may have different recommendations for stencil design.

GENERIC PACKAGE VIEW

DBQ 16

SSOP - 1.75 mm max height

SHRINK SMALL-OUTLINE PACKAGE

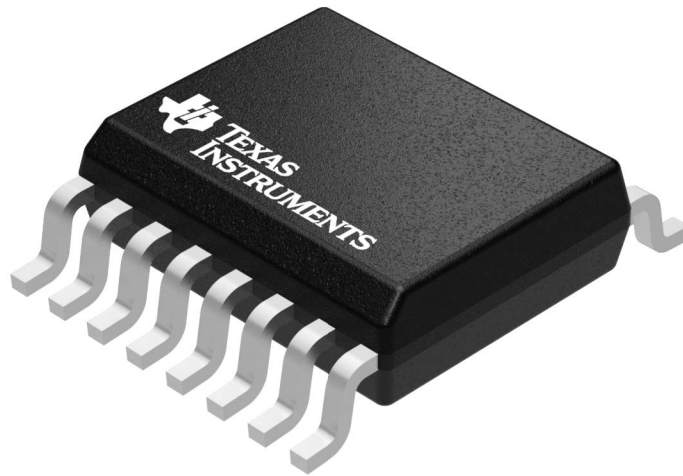

Images above are just a representation of the package family, actual package may vary.
Refer to the product data sheet for package details.

4073301-2/1



DBQ0016A

PACKAGE OUTLINE

SSOP - 1.75 mm max height

SHRINK SMALL-OUTLINE PACKAGE

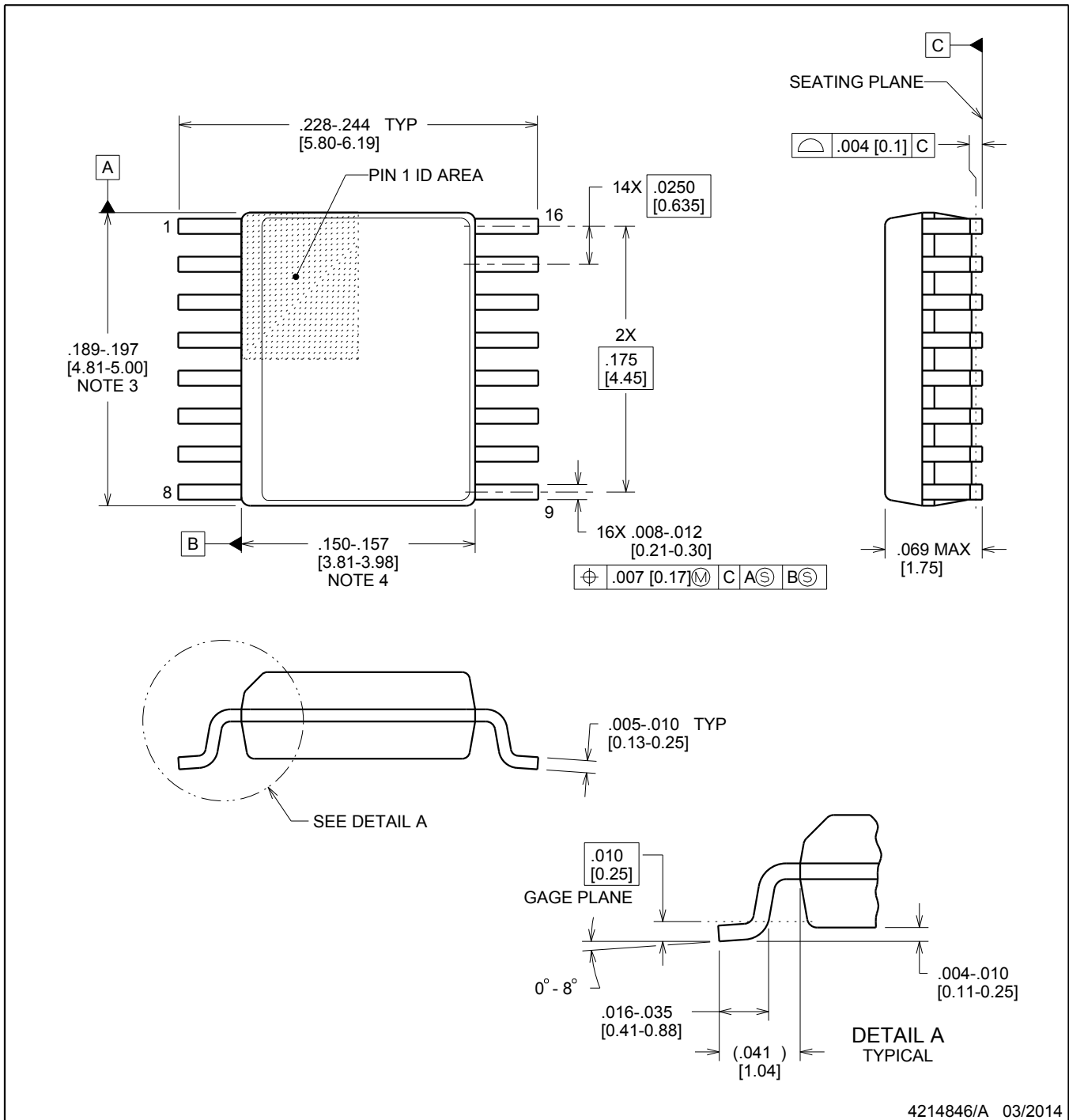

4214846/A 03/2014

NOTES:

- Linear dimensions are in inches [millimeters]. Dimensions in parenthesis are for reference only. Controlling dimensions are in inches. Dimensioning and tolerancing per ASME Y14.5M.
- This drawing is subject to change without notice.
- This dimension does not include mold flash, protrusions, or gate burrs. Mold flash, protrusions, or gate burrs shall not exceed .006 inch, per side.
- This dimension does not include interlead flash.
- Reference JEDEC registration MO-137, variation AB.

EXAMPLE BOARD LAYOUT

DBQ0016A

SSOP - 1.75 mm max height

SHRINK SMALL-OUTLINE PACKAGE



LAND PATTERN EXAMPLE
SCALE:8X



SOLDER MASK DETAILS

4214846/A 03/2014

NOTES: (continued)

- 6. Publication IPC-7351 may have alternate designs.
- 7. Solder mask tolerances between and around signal pads can vary based on board fabrication site.

EXAMPLE STENCIL DESIGN

DBQ0016A

SSOP - 1.75 mm max height

SHRINK SMALL-OUTLINE PACKAGE



SOLDER PASTE EXAMPLE
BASED ON .005 INCH [0.127 MM] THICK STENCIL
SCALE:8X

4214846/A 03/2014

NOTES: (continued)

- 8. Laser cutting apertures with trapezoidal walls and rounded corners may offer better paste release. IPC-7525 may have alternate design recommendations.
- 9. Board assembly site may have different recommendations for stencil design.

IMPORTANT NOTICE AND DISCLAIMER

TI PROVIDES TECHNICAL AND RELIABILITY DATA (INCLUDING DATASHEETS), DESIGN RESOURCES (INCLUDING REFERENCE DESIGNS), APPLICATION OR OTHER DESIGN ADVICE, WEB TOOLS, SAFETY INFORMATION, AND OTHER RESOURCES "AS IS" AND WITH ALL FAULTS, AND DISCLAIMS ALL WARRANTIES, EXPRESS AND IMPLIED, INCLUDING WITHOUT LIMITATION ANY IMPLIED WARRANTIES OF MERCHANTABILITY, FITNESS FOR A PARTICULAR PURPOSE OR NON-INFRINGEMENT OF THIRD PARTY INTELLECTUAL PROPERTY RIGHTS.

These resources are intended for skilled developers designing with TI products. You are solely responsible for (1) selecting the appropriate TI products for your application, (2) designing, validating and testing your application, and (3) ensuring your application meets applicable standards, and any other safety, security, or other requirements. These resources are subject to change without notice. TI grants you permission to use these resources only for development of an application that uses the TI products described in the resource. Other reproduction and display of these resources is prohibited. No license is granted to any other TI intellectual property right or to any third party intellectual property right. TI disclaims responsibility for, and you will fully indemnify TI and its representatives against, any claims, damages, costs, losses, and liabilities arising out of your use of these resources.

TI's products are provided subject to TI's Terms of Sale (www.ti.com/legal/termsofsale.html) or other applicable terms available either on ti.com or provided in conjunction with such TI products. TI's provision of these resources does not expand or otherwise alter TI's applicable warranties or warranty disclaimers for TI products.

Mailing Address: Texas Instruments, Post Office Box 655303, Dallas, Texas 75265
Copyright © 2020, Texas Instruments Incorporated