

LTC1645

Dual-Channel Hot Swap Controller/Power Sequencer

DESCRIPTION

Demonstration circuit 1356A is a dual hot swap circuit featuring the **LTC®1645** dual-channel hot swap controller/power sequencer.

DC1356A facilitates evaluation of the LTC1645 performance characteristics including supply ramp-up transients, steady state operation, and overcurrent fault conditions.

The first LTC1645 channel controls a rail from 2.375V to 12.0V, and the second one from 1.2V to 12.0V.

DC1356A is assembled to operate with a 5V rail with 5A nominal current (channel 1) and a 3.3V rail with 7A nominal current (channel 2).

Design files for this circuit board are available at <http://www.linear.com/demo/DC1356A>

LT, LT, LTC, LTM, Linear Technology and the Linear logo are registered trademarks of Linear Technology Corporation. All other trademarks are the property of their respective owners.

PERFORMANCE SUMMARY Specifications are at T_A = 25°C

SYMBOL	PARAMETER	CONDITIONS	MIN	TYP	MAX	UNITS
V _{CC1}	Supply Voltage Channel 1		2.375		12	V
V _{CC2}	Supply Voltage Channel 2		1.2		12	V
V _{LK01_C1(UVL)}	V _{CC1} Undervoltage Lockout	High to Low	2.16	2.23	2.3	V
V _{LK02_C2(UVL)}	V _{CC2} Undervoltage Lockout	High to Low	1.06	1.12	1.18	V
V _{LKHn}	V _{CCn} Undervoltage Lockout Hysteresis			25		mV
V _{CB1}	Circuit Breaker Trip Voltage 1	V _{CB1} = (V _{CC1} - V _{SENSE1})	46	50	56	mV
V _{CB2}	Circuit Breaker Trip Voltage 2	V _{CB2} = (V _{CC2} - V _{SENSE2})	46	50	56	mV
ΔV _{GATEn}	External N-Channel Gate Drive		4.5		16	V
V _{ONFPD}	ON Pin Fast Pull-Down Threshold	Low to High High to Low, Fast Pull-Down Engaged	0.375 0.35	0.4 0.375	0.425 0.4	V V
V _{ON1}	ON Pin Threshold #1	Low to High, GATE1 Turns On High to Low, GATE1 Turns Off	0.8 0.775	0.825 0.8	0.85 0.825	V V
V _{ON2}	ON Pin Threshold #2	Low to High, GATE2 Turns On High to Low, GATE2 Turns Off	2 1.975	2.025 2	2.050 2.025	V V
V _{ONHYST}	ON Pin Hysteresis			25		mV
V _{TM}	Timer Pin Voltage Threshold		1.212	1.230	1.255	V
I _{TM}	Timer Pin Current	Timer On, V _{TIMER} = 0.6V, V _{CC1} = 5V Timer Off, V _{TIMER} = 1.5V	-2.3	-2 12	-1.7	μA mA
I _{CP}	GATEn Pin Output Current	ON = 2.2V, V _{GATEn} = V _{CCn} , V _{CC1} = 5V, V _{CC2} = 3.3V ON = 0.7V, V _{GATEn} = V _{CCn} , V _{CC1} = 5V, V _{CC2} = 3.3V ON = 0.3V, V _{GATEn} = V _{CCn} , V _{CC1} = 5V, V _{CC2} = 3.3V	-12.5 30	-10 40 12	-7.5 50	μA μA mA

The LTC1645 controls two rails with external N-channel MOSFETs.

The ON pin is an analog control input connected to three internal comparators, allowing the rails to ramp up and down. If the ON pin voltage is below 0.4V, both GATE1 and GATE2 are immediately pulled to ground. If ON voltage is between 0.4V and 0.8V, both GATE1 and GATE2 are each pulled to ground with a 40 μ A current source. When the voltage is between 0.8V and 2V, the GATE1 pull-up is turned on, but GATE2 continues to be pulled to ground with a 40 μ A current source. With the voltage exceeding 2V, both the GATE1 and GATE2 pull-ups are turned on.

Each channel has an overcurrent circuit breaker comparator for load protection. The circuit breaker trips if the current sense voltage exceeds 50mV for 1.5 μ s.

The LTC1645 is suited for low voltage applications such as board hot insertion and removal and has a rich set of features to support hot swap application including:

- Programmable circuit breakers
- Programmable power supply sequencing

QUICK START PROCEDURE

DC1356A is easy to set up to evaluate the performance of the LTC1645. Refer to Figure 1 for proper measurement equipment setup and follow the procedure below:

1. Place jumpers in the initial position:

JP1 (ON1) OFF

JP2 (ON2) OFF

JP3 (SEQUENCE) OFF

JP4 (BOTH OFF) NO

JP5 (DELAY) OFF

2. Adjust 5V supply output voltage between 4.8V and 5.2V. Connect 5V power supply to the 5V input and GND turrets, and turn it on. The green LED 5V input (D2) should light up. Place jumper JP1 in ON position. The green LED 5V OUT (D1) should light up.

3. Adjust 3.3V supply output voltage between 2.89V and 3.67V. Connect 3.3V power supply to the 3.3V input and GND turrets and turn it on. Green LED 3.3V input (D6) should light up. Place jumper JP2 (ON2) in ON position. Green LED 3.3V output (D5) should light up.

4. Turn both power supplies off. Keep jumper JP1 in the ON position, place jumper JP2 (ON2) in the OFF position and jumper JP3 (sequence) in the ON position. Turn 3.3V supply ON and a couple seconds later turn on the 5V supply. Observe power supply sequencing.

5. Connect electronic or resistive loads to the 5V and 3.3V output turrets.

6. Activate both loads with lower than 1A for each rail. Increase load current, use a current probe or meter and verify the circuit breaker threshold level. For the 5V circuit it should be between 4.55A and 5.65A, for the 3.3V circuit, between 6.5A and 8.1A.

QUICK START PROCEDURE

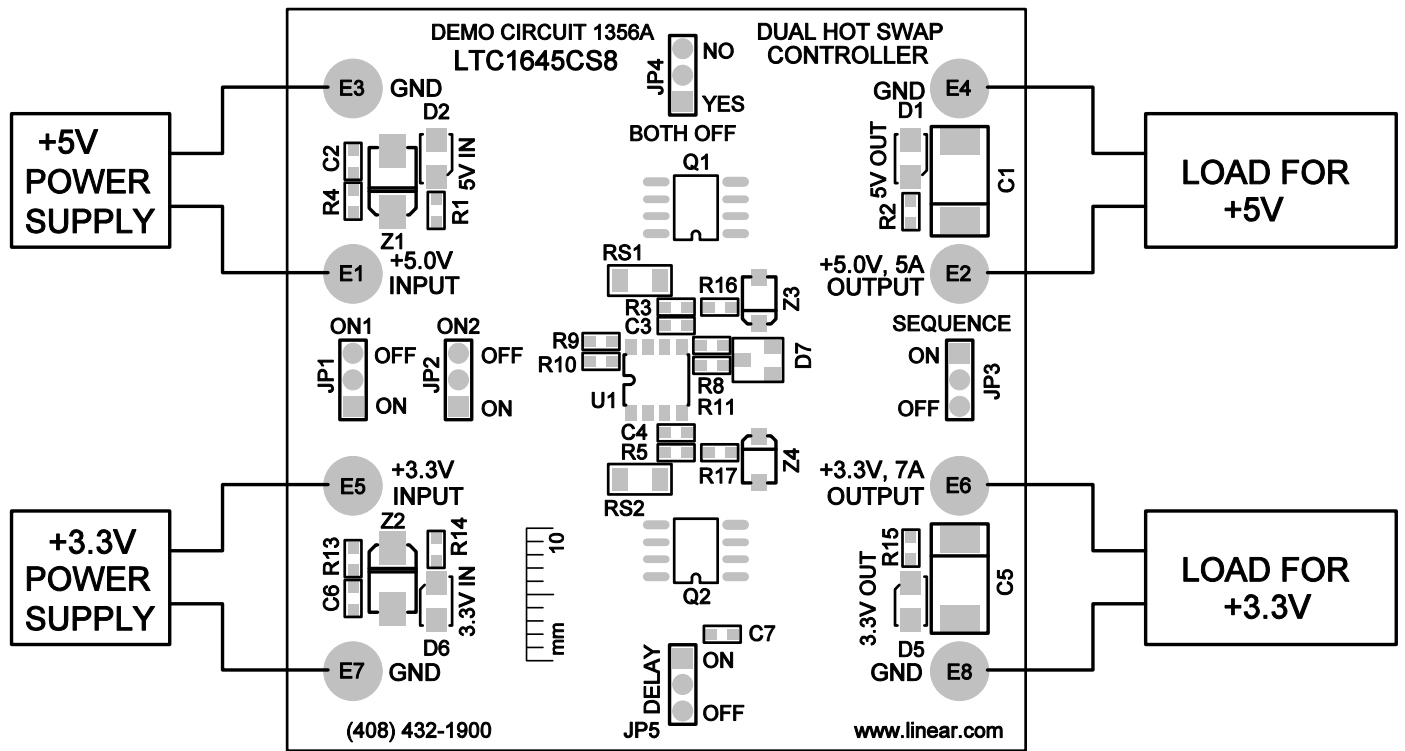

Figure 1. DC1356A Measurement Equipment Setup

DEMO MANUAL DC1356A

PARTS LIST

ITEM	QTY	REFERENCE	PART DESCRIPTION	MANUFACTURER/PART NUMBER
1	2	C1, C5	CAP, 220uF 20% 16V TANT.	AVX TAJE227M016R
2	4	C2, C3, C4, C6	CAP, 0603 0.1uF 10% 10V X7R	AVX 0603ZC104KAT
3	1	C7	CAP, 0603 1uF 10% 16V X7R	TDK C1608X7R1C105K
4	4	D1, D2, D5, D6	LED, GREEN	PANASONIC LN1351C
5	1	D7	DIODE, SCHOTTKY 200mW SOT-23	DIODES INC. BAT54-7-F
6	8	E1, E2, E3, E4, E5, E6, E7, E8	TURRET	MILL-MAX 2501-2-00-80-00-00-07-0
7	5	JP1, JP2, JP3, JP4, JP5	HEADER, 3-PIN, 2mm	WURTH ELEKTRONIK 62000311121
8	2	Q1, Q2	XSTR, N-CHANNEL MOSFET	INTERNATIONAL RECTIFIER IRF7413
9	1	RS1	RES, 1206 0.010Ω 1% 1/2W	VISHAY WSL1206R0100FEA
10	1	RS2	RES, 1206 0.007Ω 1% 1/2W	VISHAY WSL12067L00FEA
11	2	R1, R2	RES, 0603 3kΩ 5% 1/10W	VISHAY CRCW06033K00JNEA
12	4	R3, R4, R5, R13	RES, 0603 10Ω 5% 1/10W	VISHAY CRCW060310R0JNEA
13	1	R8	RES, 0603 10kΩ 5% 1/10W	VISHAY CRCW060310K0JNEA
14	1	R9	RES, 0603 26.7kΩ 1% 1/10W	VISHAY CRCW060326K7FKEA
15	1	R10	RES, 0603 7.15kΩ 1% 1/10W	VISHAY CRCW06037K15FKEA
16	1	R11	RES, 0603 4.42kΩ 1% 1/10W	VISHAY CRCW06034K42FKEA
17	2	R14, R15	RES, 0603 1.5kΩ 5% 1/10W	VISHAY CRCW06031K50JNEA
18	2	R16, R17	RES, 0603 604Ω 1% 0.1W	VISHAY CRCW0603604RFKEA
19	1	U1	IC, DUAL HOT SWAP CONTROLLER	LINEAR TECH LTC1645CS8#PBF
20	5	XJP1, XJP2, XJP3, XJP4, XJP5	SHUNT, 2mm	WURTH ELEKTRONIK 60800213421
21	2	Z1, Z2	DIODE, TRANSIENT VOTAGE SUPPRESSOR	DIODES INC. SMAJ10A-13-F
22	2	Z3, Z4	DIODE, ZENER 18V	DIODES INC. DDZ9705-7
	0	Z3, Z4 - ALTERNATE	DIODE, ZENER 18V	CENTRAL SEMI. CMHZ4705

SCHEMATIC DIAGRAM

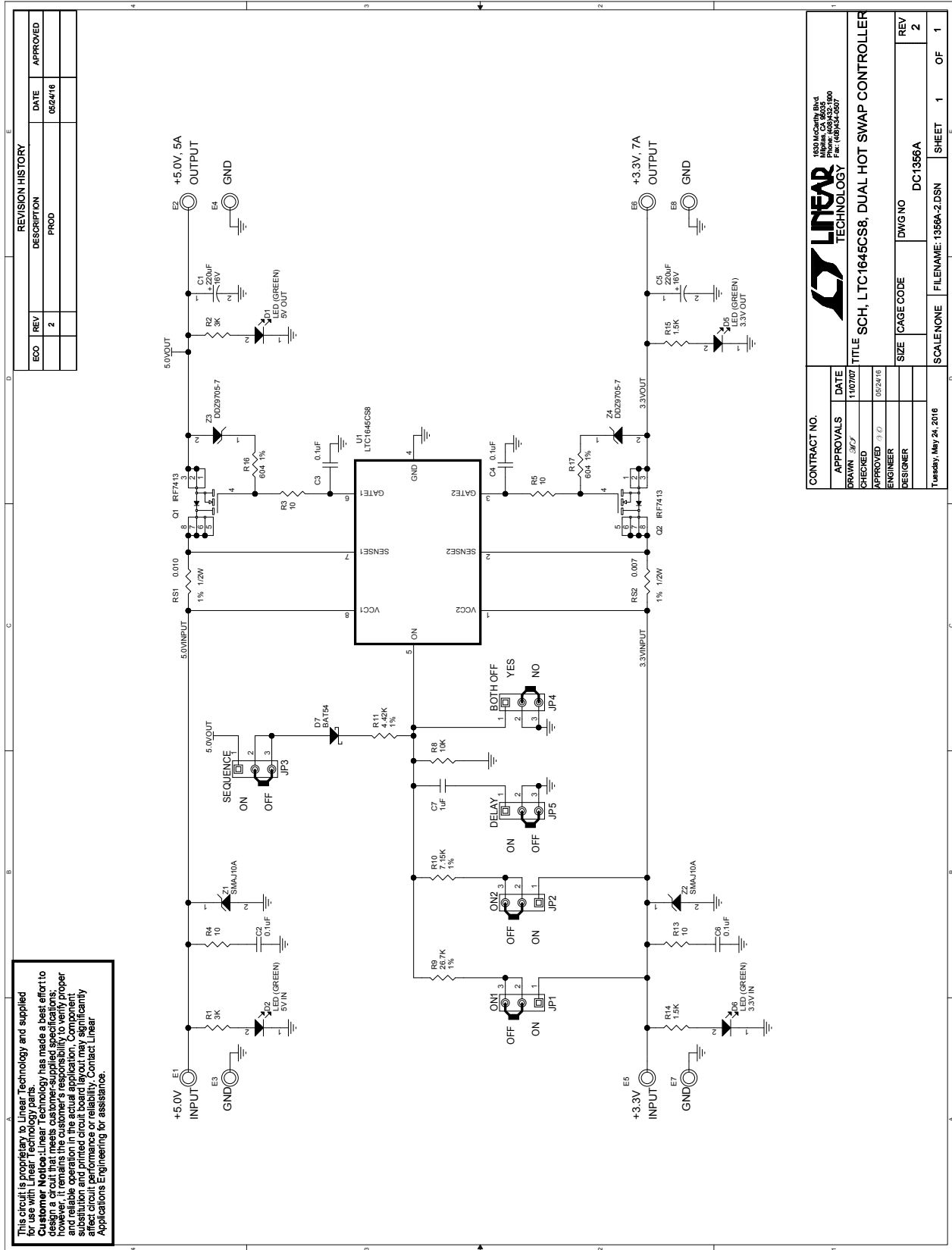

This circuit is proprietary to Linear Technology and supplied to you under a Non-Disclosure Agreement. Linear Technology has made a best effort to design a circuit that meets customer-specified specifications; however, it remains the customer's responsibility to verify proper and reliable operation in the actual application. Component values are shown for illustrative purposes only. Linear Technology Applications Engineering for assistance.

DEMO MANUAL DC1356A

DEMONSTRATION BOARD IMPORTANT NOTICE

Linear Technology Corporation (LTC) provides the enclosed product(s) under the following **AS IS** conditions:

This demonstration board (DEMO BOARD) kit being sold or provided by Linear Technology is intended for use for **ENGINEERING DEVELOPMENT OR EVALUATION PURPOSES ONLY** and is not provided by LTC for commercial use. As such, the DEMO BOARD herein may not be complete in terms of required design-, marketing-, and/or manufacturing-related protective considerations, including but not limited to product safety measures typically found in finished commercial goods. As a prototype, this product does not fall within the scope of the European Union directive on electromagnetic compatibility and therefore may or may not meet the technical requirements of the directive, or other regulations.

If this evaluation kit does not meet the specifications recited in the DEMO BOARD manual the kit may be returned within 30 days from the date of delivery for a full refund. **THE FOREGOING WARRANTY IS THE EXCLUSIVE WARRANTY MADE BY THE SELLER TO BUYER AND IS IN LIEU OF ALL OTHER WARRANTIES, EXPRESSED, IMPLIED, OR STATUTORY, INCLUDING ANY WARRANTY OF MERCHANTABILITY OR FITNESS FOR ANY PARTICULAR PURPOSE. EXCEPT TO THE EXTENT OF THIS INDEMNITY, NEITHER PARTY SHALL BE LIABLE TO THE OTHER FOR ANY INDIRECT, SPECIAL, INCIDENTAL, OR CONSEQUENTIAL DAMAGES.**

The user assumes all responsibility and liability for proper and safe handling of the goods. Further, the user releases LTC from all claims arising from the handling or use of the goods. Due to the open construction of the product, it is the user's responsibility to take any and all appropriate precautions with regard to electrostatic discharge. Also be aware that the products herein may not be regulatory compliant or agency certified (FCC, UL, CE, etc.).

No License is granted under any patent right or other intellectual property whatsoever. **LTC assumes no liability for applications assistance, customer product design, software performance, or infringement of patents or any other intellectual property rights of any kind.**

LTC currently services a variety of customers for products around the world, and therefore this transaction **is not exclusive**.

Please read the DEMO BOARD manual prior to handling the product. Persons handling this product must have electronics training and observe good laboratory practice standards. **Common sense is encouraged.**

This notice contains important safety information about temperatures and voltages. For further safety concerns, please contact a LTC application engineer.

Mailing Address:

Linear Technology
1630 McCarthy Blvd.
Milpitas, CA 95035

Copyright © 2004, Linear Technology Corporation