



ON Semiconductor®

October 2017

FOD8318

2.5 A Output Current, IGBT Drive Optocoupler with Active Miller Clamp, Desaturation Detection, and Isolated Fault Sensing

Features

- High noise immunity characterized by common mode rejection
 - 35 kV / μ s Minimum Common Mode Rejection ($V_{cm} = 1500 V_{peak}$)
- 2.5 A peak output current driving capability for most 1200 V / 150 A IGBT
- Optically isolated fault sensing feedback
- Active Miller clamp to shut off the IGBT during high dv/dt without needing a negative supply voltage
- “Soft” IGBT turn-off
- Built-in IGBT protection
 - Desaturation detection
 - Under-voltage lock out (UVLO) protection
- Wide supply voltage range from 15 V to 30 V
 - Use of P-Channel MOSFETs at output stage enables output voltage swing close to the supply rail (rail-to-rail output)
- 3.3 V / 5 V, CMOS/TTL-compatible inputs
- High Speed
 - 250 ns max. propagation delay over full operating temperature range
- Extended industrial temperature range, -40°C to 100°C temperature range
- Safety and regulatory approvals
 - UL1577, 4,243 V_{RMS} for 1 min.
 - DIN EN/IEC 60747-5-5, 1,414 V_{peak} working insulation voltage, 8000 V_{peak} transient isolation voltage ratings
- $R_{DS(ON)}$ of 1 Ω (typ.) offers lower power dissipation
- User configurable: inverting, non-inverting, auto-reset, auto-shutdown
- 8 mm creepage and clearance distances

Applications

- Industrial inverter
- Induction heating
- Isolated IGBT drive

Description

The FOD8318 is an advanced 2.5 A output current IGBT drive optocoupler capable of driving most 1200 V / 150 A IGBTs. It is ideally suited for fast-switching driving of power IGBTs and MOSFETs used in motor control inverter applications and high-performance power systems. It consists of an integrated gate drive optocoupler featuring low $R_{DS(ON)}$ CMOS transistors to drive the IGBT from rail to rail and an integrated high-speed isolated feedback for fault sensing. The FOD8318 has an active Miller clamp function to shut off the IGBT during a high dv/dt situation without the need of a negative supply voltage. It offers critical protection features necessary for preventing fault conditions that lead to destructive thermal runaway of IGBTs.

It utilizes ON's proprietary Optoplanar® coplanar packaging technology and optimized IC design to achieve high noise immunity, characterized by high common mode rejection and power supply rejection specifications.

The device is housed in a compact 16-pin small outline plastic package that meets the 8 mm creepage and clearance requirements.

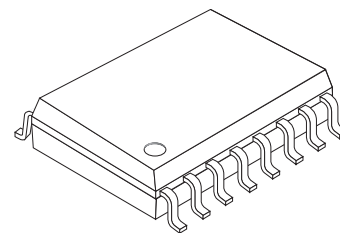

FOD8318 — 2.5 A Output Current, IGBT Drive Optocoupler with Active Miller Clamp, Desaturation Detection, and Isolated Fault Sensing

Truth Table

V_{IN+}	V_{IN-}	UVLO ($V_{DD2} - V_E$)	DESAT Detected?	$\overline{\text{FAULT}}$	V_{OUT}^*
X	X	Active	X	X	LOW
X	X	X	Yes	LOW	LOW
LOW	X	X	X	X	LOW
X	HIGH	X	X	X	LOW
HIGH	LOW	Not Active	No	HIGH	HIGH

* V_{OUT} is always LOW with 'clamp' being active (gate voltage < 2 V above V_{SS}).

Pin Definitions

Pin #	Name	Description
1	V_{IN+}	Non-inverting gate drive control input
2	V_{IN-}	Inverting gate drive control input
3	V_{DD1}	Positive input supply voltage (3 V to 5.5 V)
4	GND1	Input ground
5	$\overline{\text{RESET}}$	Fault reset input
6	$\overline{\text{FAULT}}$	Fault output
7	V_{LED1+}	LED 1 anode (must be left unconnected)
8	V_{LED1-}	LED 1 cathode (must be connected to ground)
9	V_{SS}	Output supply voltage (negative)
10	V_{CLAMP}	Active Miller clamp supply voltage
11	V_O	Gate drive output voltage
12	V_S	Source of pull-up PMOS transistor
13	V_{DD2}	Positive output supply voltage
14	DESAT	Desaturation voltage input
15	V_{LED2+}	LED 2 anode (must be left unconnected)
16	V_E	Output supply voltage / IGBT emitter

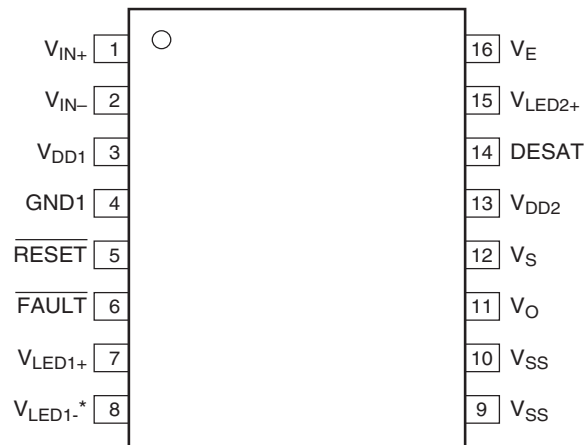

Block Diagram

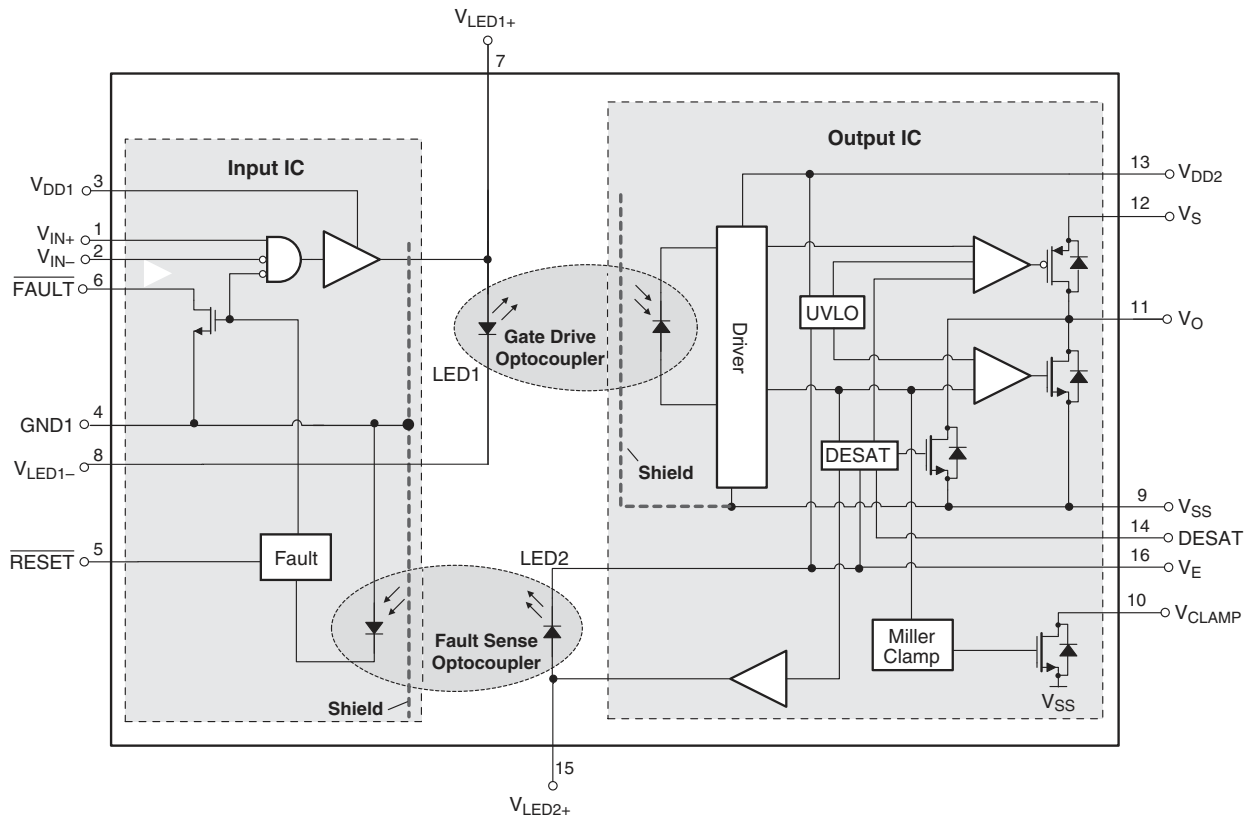

Safety and Insulation Ratings

As per DIN EN/IEC 60747-5-5. This optocoupler is suitable for “safe electrical insulation” only within the safety limit data. Compliance with the safety ratings shall be ensured by means of protective circuits.

Symbol	Parameter	Min.	Typ.	Max.	Unit
	Installation Classifications per DIN VDE 0110/1.89 Table 1				
	For Rated Mains Voltage < 150 Vrms		I-IV		
	For Rated Mains Voltage < 300 Vrms		I-IV		
	For Rated Mains Voltage < 450 Vrms		I-IV		
	For Rated Mains Voltage < 600 Vrms		I-IV		
	For Rated Mains Voltage < 1000 Vrms		I-III		
	Climatic Classification		40/100/21		
	Pollution Degree (DIN VDE 0110/1.89)		2		
CTI	Comparative Tracking Index	175			
V _{PR}	Input to Output Test Voltage, Method b, V _{IORM} × 1.875 = V _{PR} , 100 % Production Test with t _m = 1 s, Partial Discharge < 5 pC	2,651			V _{peak}
	Input to Output Test Voltage, Method a, V _{IORM} × 1.5 = V _{PR} , Type and Sample Test with t _m = 60 s, Partial Discharge < 5 pC	2,121			V _{peak}
V _{IORM}	Maximum Working Insulation Voltage	1,414			V _{peak}
V _{IOTM}	Highest Allowable Over Voltage	8,000			V _{peak}
	External Creepage	8			mm
	External Clearance	8			mm
	Insulation Thickness	0.5			mm
T _{Case}	Safety Limit Values – Maximum Values Allowed in the Event of a Failure				
	Case Temperature	150			°C
P _{S,INPUT}	Input Power	100			mW
P _{S,OUTPUT}	Output Power	600			mW
R _{IO}	Insulation Resistance at T _S , V _{IO} = 500 V	10 ⁹			Ω

Absolute Maximum Ratings ($T_A = 25\text{ }^\circ\text{C}$ unless otherwise specified)

Stresses exceeding the absolute maximum ratings may damage the device. The device may not function or be operable above the recommended operating conditions and stressing the parts to these levels is not recommended. In addition, extended exposure to stresses above the recommended operating conditions may affect device reliability. The absolute maximum ratings are stress ratings only.

Symbol	Parameter	Value	Units
T_{STG}	Storage Temperature	-40 to +125	$^\circ\text{C}$
T_{OPR}	Operating Temperature	-40 to +100	$^\circ\text{C}$
T_J	Junction Temperature	-40 to +125	$^\circ\text{C}$
T_{SOL}	Lead Wave Solder Temperature (no solder immersion) <i>Refer to page 28 for reflow temperature profile.</i>	260 for 10 s	$^\circ\text{C}$
I_{FAULT}	Fault Output Current	15	mA
$I_{O(PEAK)}$	Peak Output Current ⁽¹⁾	3	A
$V_E - V_{SS}$	Negative Output Supply Voltage ⁽²⁾	0 to 15	V
$V_{DD2} - V_E$	Positive Output Supply Voltage	-0.5 to 35 – ($V_E - V_{SS}$)	V
$V_{O(peak)}$	Gate Drive Output Voltage	-0.5 to 35	V
$V_{DD2} - V_{SS}$	Output Supply Voltage	-0.5 to 35	V
V_{DD1}	Positive Input Supply Voltage	-0.5 to 6	V
V_{IN+} , V_{IN-} and V_{RESET}	Input Voltages	-0.5 to V_{DD1}	V
V_{FAULT}	Fault Pin Voltage	-0.5 to V_{DD1}	V
V_S	Source of Pull-up PMOS Transistor Voltage	$V_{SS} + 6.5$ to V_{DD2}	V
V_{DESAT}	DESAT Voltage	V_E to $V_E + 25$	V
I_{CLAMP}	Peaking Clamping Sinking Current	1.7	A
V_{CLAMP}	Miller Clamping Voltage	-0.5 to V_{DD2}	V
PD_I	Input Power Dissipation ⁽³⁾⁽⁵⁾	100	mW
PD_O	Output Power Dissipation ⁽⁴⁾⁽⁵⁾	600	mW

Notes:

1. Maximum pulse width = 10 μs , maximum duty cycle = 0.2 %.
2. This negative output supply voltage is optional. It's only needed when negative gate drive is implemented. A schottky diode is recommended to be connected between V_E and V_{SS} to protect against a reverse voltage greater than 0.5 V. Refer to application information, "6. Active Miller Clamp Function" on page 25.
3. No derating required across temperature range.
4. Derate linearly above 64 $^\circ\text{C}$, free air temperature at a rate of 10.2 mW/ $^\circ\text{C}$
5. Functional operation under these conditions is not implied. Permanent damage may occur if the device is subjected to conditions outside these ratings.

Recommended Operating Conditions

The Recommended Operating Conditions table defines the conditions for actual device operation. Recommended operating conditions are specified to ensure optimal performance to the datasheet specifications. ON does not recommend exceeding them or designing to absolute maximum ratings.

Symbol	Parameter	Min.	Max.	Unit
T_A	Ambient Operating Temperature	-40	+100	°C
V_{DD1}	Input Supply Voltage ⁽⁶⁾	3	5.5	V
$V_{DD2} - V_{SS}$	Total Output Supply Voltage	15	30	V
$V_E - V_{SS}$	Negative Output Supply Voltage	0	15	V
$V_{DD2} - V_E$	Positive Output Supply Voltage ⁽⁶⁾	15	$30 - (V_E - V_{SS})$	V
V_S	Source of Pull-up PMOS Transistor Voltage	$V_{SS} + 7.5$	V_{DD2}	V

Note:

- During power up or down, it is important to ensure that VIN+ remains LOW until both the input and output supply voltages reach the proper recommended operating voltage to avoid any momentary instability at the output state. Refer to "Time to Good Power" section on page 25.

Isolation Characteristics

Apply over all recommended conditions, typical value is measured at $T_A = 25\text{ °C}$

Symbol	Parameter	Conditions	Min.	Typ.	Max.	Units
V_{ISO}	Input-Output Isolation Voltage	$T_A = 25\text{ °C}$, R.H. < 50 %, $t = 1.0\text{ min}$, $I_{I-O} \leq 10\text{ }\mu\text{A}$, 50 Hz ⁽⁷⁾⁽⁸⁾⁽⁹⁾	4,243			V_{RMS}
R_{ISO}	Isolation Resistance	$V_{I-O} = 500\text{ V}^{(7)}$		10^{11}		Ω
C_{ISO}	Isolation Capacitance	$V_{I-O} = 0\text{ V}$, freq = 1.0 MHz ⁽⁷⁾		1		pF

Notes:

- Device is considered a two terminal device: pins 1 to 8 are shorted together and pins 9 to 16 are shorted together.
- 4,243 V_{RMS} for 1-minute duration is equivalent to 5,091 V_{RMS} for 1-second duration.
- The Input-Output Isolation Voltage is a dielectric voltage rating as per UL1577. It should not be regarded as an input-output continuous voltage rating. For the continuous working voltage rating, refer to the equipment level safety specification or *DIN EN/IEC 60747-5-5 Safety and Insulation Ratings Table* on page 4.

Electrical Characteristics

Apply over all recommended conditions; typical value is measured at $V_{DD1} = 5\text{ V}$, $V_{DD2} - V_{SS} = 30\text{ V}$, $V_E - V_{SS} = 0\text{ V}$, $T_A = 25\text{ °C}$ unless otherwise specified.

Symbol	Parameter	Conditions	Min.	Typ.	Max.	Units	Figure
V_{IN+L} , V_{IN-L} , V_{RESETL}	Logic Low Input Voltages				0.8	V	
V_{IN+H} , V_{IN-H} , V_{RESETH}	Logic High Input Voltages		2.0			V	
I_{IN+L} , I_{IN-L} , I_{RESETL}	Logic Low Input Currents	$V_{IN} = 0.4\text{ V}$	-0.5	-0.001		mA	
I_{FAULTL}	$\overline{\text{FAULT}}$ Logic Low Output Current	$V_{\overline{\text{FAULT}}} = 0.4\text{ V}$	5.0	12.0		mA	1, 35
I_{FAULTH}	$\overline{\text{FAULT}}$ Logic High Output Current	$V_{\overline{\text{FAULT}}} = V_{DD1}$	-40	0.002		μA	35

Electrical Characteristics (Continued)

Apply over all recommended conditions; typical value is measured at $V_{DD1} = 5\text{ V}$, $V_{DD2} - V_{SS} = 30\text{ V}$, $V_E - V_{SS} = 0\text{ V}$, $T_A = 25\text{ }^\circ\text{C}$ unless otherwise specified.

Symbol	Parameter	Conditions	Min.	Typ.	Max.	Units	Figure
I_{OH}	High Level Output Current	$V_O = V_{DD2} - 3\text{ V}$	-1	-2.5		A	2, 7, 36
		$V_O = V_{DD2} - 6\text{ V}^{(10)}$	-2.5			A	
I_{OL}	Low Level Output Current	$V_O = V_{SS} + 3\text{ V}$	1	3		A	3, 37
		$V_O = V_{SS} + 6\text{ V}^{(11)}$	2.5			A	
I_{OLF}	Low Level Output Current During Fault Condition	$V_O - V_{SS} = 14\text{ V}$	70	125	170	mA	4, 41
V_{OH}	High Level Output Voltage	$I_O = -100\text{ mA}$ (12)(13)(14)	$V_S - 1.0\text{ V}$	$V_S - 0.5\text{ V}$		V	5, 7, 38
V_{OL}	Low Level Output Voltage	$I_O = 100\text{ mA}$		0.1	0.5	V	6, 8, 38
I_{DD1H}	High Level Supply Current	$V_{IN+} = V_{DD1} = 5.5\text{ V}$, $V_{IN-} = 0\text{ V}$		14	17	mA	9, 39
I_{DD1L}	Low Level Supply Current	$V_{IN+} = V_{IN-} = 0\text{ V}$, $V_{DD1} = 5.5\text{ V}$		2	3	mA	
I_{DD2H}	High Level Output Supply Current	$V_O = \text{Open}^{(14)}$		1.7	3	mA	10, 11, 40
I_{DD2L}	Low Level Output Supply Current	$V_O = \text{Open}$		1.8	2.8	mA	
I_{SH}	High Level Source Current	$I_O = 0\text{ mA}$		0.65	1.5	mA	40
I_{SL}	Low Level Source Current	$I_O = 0\text{ mA}$		0.6	1.4	mA	40
I_{EL}	V_E Low Level Supply Current		-0.8	-0.5		mA	13, 40
I_{EH}	V_E High Level Supply Current		-0.5	-0.25		mA	
I_{CHG}	Blanking Capacitor Charge Current	$V_{DESAT} = 2\text{ V}^{(14)(15)}$	-0.13	-0.25	-0.33	mA	12, 41
I_{DSCHG}	Blanking Capacitor Discharge Current	$V_{DESAT} = 7\text{ V}$	10	36		mA	41
V_{UVLO+}	Under-Voltage Lockout Threshold ⁽¹⁴⁾	$V_O > 5\text{ V}$ at $25\text{ }^\circ\text{C}$	10.8	11.7	12.7	V	15, 29, 42
V_{UVLO-}		$V_O < 5\text{ V}$ at $25\text{ }^\circ\text{C}$	9.8	10.7	11.7	V	
$UVLO_{HYS}$	Under-Voltage Lockout Threshold Hysteresis	At $25\text{ }^\circ\text{C}$	0.4	1.0		V	
V_{DESAT}	DESAT Threshold ⁽¹⁴⁾	$V_{DD2} - V_E > V_{UVLO-}$, $V_O < 5\text{ V}$	6.0	6.5	7.2	V	16, 41
V_{CLAMP_THRES}	Clamping Threshold Voltage			2.2		V	33, 52
I_{CLAMPL}	Clamp Low Level Sinking Current	$V_O = V_{SS} + 2.5\text{ V}$	0.35	1.2		A	32, 51

Notes:

10. Maximum pulse width = 10 μs , maximum duty cycle = 0.2 %.
11. Maximum pulse width = 4.99 ms, maximum duty cycle = 99.8 %.
12. V_{OH} is measured with the DC load current in this testing (maximum pulse width = 1 ms, maximum duty cycle = 20 %). When driving capacitive loads, V_{OH} approaches V_{DD} as I_{OH} approaches zero units.
13. Positive output supply voltage ($V_{DD2} - V_E$) should be at least 15 V. This ensures adequate margin in excess of the maximum under-voltage lockout threshold V_{UVLO+} of 13.5 V.
14. When $V_{DD2} - V_E > V_{UVLO}$ and output state V_O of the FOD8318 is allowed to go HIGH, the DESAT detection feature is active and provides the primary source of IGBT protection. UVLO is needed to ensure DESAT detection is functional.

15. The blanking time, t_{BLANK} , is adjustable by an external capacitor (C_{BLANK}) where $t_{BLANK} = C_{BLANK} * (V_{DESAT} / I_{CHG})$.

Switching Characteristics

Apply over all recommended conditions; typical value is measured at $V_{DD1} = 5\text{ V}$, $V_{DD2} - V_{SS} = 30\text{ V}$, $V_E - V_{SS} = 0\text{ V}$, $T_A = 25\text{ °C}$ unless otherwise specified.

Symbol	Parameter	Conditions	Min.	Typ.	Max.	Units	Figure	
t_{PHL}	Propagation Delay Time to Logic Low Output ⁽¹⁷⁾	Rg = 10 Ω , Cg = 10 nF, f = 10 kHz, Duty Cycle = 50 % ⁽¹⁶⁾		140	250	ns	17, 18, 19, 20, 21, 22, 43, 51	
t_{PLH}	Propagation Delay Time to Logic High Output ⁽¹⁸⁾			160	250	ns		
PWD	Pulse Width Distortion, $t_{PHL} - t_{PLH}$ ⁽¹⁹⁾			20	100	ns		
PDD Skew	Propagation Delay Difference Between Any Two Parts or Channels, ($t_{PHL} - t_{PLH}$) ⁽²⁰⁾			-150	150	ns		
t_R	Output Rise Time (10 % – 90 %)				25		ns	43, 53
t_F	Output Fall Time (90 % – 10 %)				25		ns	
$t_{DESAT(90\%)}$	DESAT Sense to 90 % V_O Delay ⁽²¹⁾	Rg = 10 Ω , Cg = 10 nF, $V_{DD2} - V_{SS} = 30\text{ V}$		450	700	ns	23, 44	
$t_{DESAT(10\%)}$	DESAT Sense to 10 % V_O Delay ⁽²¹⁾			2.7	4.0	μs	24, 26, 27, 44	
$t_{DESAT(\overline{FAULT})}$	DESAT Sense to Low Level \overline{FAULT} Signal Delay ⁽²²⁾			1.4	5.0	μs	25, 44, 54	
$t_{DESAT(LOW)}$	DESAT Sense to DESAT Low Propagation Delay ⁽²³⁾			250		ns	44	
$t_{RESET(\overline{FAULT})}$	\overline{RESET} to High Level \overline{FAULT} Signal Delay ⁽²⁴⁾			3	6	20	μs	28, 45, 54
$t_{DESAT(MUTE)}$	DESAT Input Mute			10	22	35	μs	
$PW_{\overline{RESET}}$	\overline{RESET} Signal Pulse Width			1.2			μs	
$t_{UVLO ON}$	UVLO Turn On Delay ⁽²⁵⁾		$V_{DD2} = 20\text{ V}$ in 1.0ms Ramp		4		μs	29, 46
$t_{UVLO OFF}$	UVLO Turn Off Delay ⁽²⁶⁾				3		μs	
t_{GP}	Time to Good Power ⁽²⁷⁾		$V_{DD2} = 0$ to 30 V in 10 μs Ramp		2.5		μs	30, 31, 46
CM_H	Common Mode Transient Immunity at Output High	$T_A = 25\text{ °C}$, $V_{DD1} = 5\text{ V}$, $V_{DD2} = 25\text{ V}$, $V_{SS} = \text{Ground}$, $V_{CM} = 1500\text{ V}_{peak}$ ⁽²⁸⁾	35	50		kV/ μs	48, 49	
CM_L	Common Mode Transient Immunity at Output Low	$T_A = 25\text{ °C}$, $V_{DD1} = 5\text{ V}$, $V_{DD2} = 25\text{ V}$, $V_{SS} = \text{Ground}$, $V_{CM} = 1500\text{ V}_{peak}$ ⁽²⁹⁾	35	50		kV/ μs	47, 50	

Notes:

16. This load condition approximates the gate load of a 1200 V / 150 A IGBT.
17. t_{PHL} propagation delay is measured from the 50 % level on the falling edge of the input pulse (V_{IN+} , V_{IN-}) to the 50 % level of the falling edge of the V_O signal. Refer to Figure 53.
18. t_{PLH} propagation delay is measured from the 50 % level on the rising edge of the input pulse (V_{IN+} , V_{IN-}) to the 50 % level of the rising edge of the V_O signal. Refer to Figure 53.
19. PWD is defined as | $t_{PHL} - t_{PLH}$ | for any given device.

20. The difference between t_{PHL} and t_{PLH} between any two FOD8318 parts under same operating conditions, with equal loads.
21. This is the amount of time the DESAT threshold must be exceeded before V_O begins to go LOW. This is supply voltage dependent. *Refer to Figure 54.*
22. This is the amount of time from when the DESAT threshold is exceeded, until the \overline{FAULT} output goes LOW. *Refer to Figure 54.*
23. This is the amount of time the DESAT threshold must be exceeded before V_O begins to go LOW and the \overline{FAULT} output to go LOW. *Refer to Figure 54.*
24. This is the amount of time from when \overline{RESET} is asserted LOW, until \overline{FAULT} output goes HIGH. *Refer to Figure 54.*
25. $t_{UVLO\ ON}$ UVLO turn-on delay is measured from V_{UVLO+} threshold voltage of the output supply voltage (V_{DD2}) to the 5 V level of the rising edge of the V_O signal.
26. $t_{UVLO\ OFF}$ UVLO turn-off delay is measured from V_{UVLO-} threshold voltage of the output supply voltage (V_{DD2}) to the 5 V level of the falling edge of the V_O signal.
27. t_{GP} time to good power is measured from 13.5 V level of the rising edge of the output supply voltage (V_{DD2}) to the 5 V level of the rising edge of the V_O signal.
28. Common mode transient immunity at output HIGH state is the maximum tolerable negative dV_{cm}/dt on the trailing edge of the common mode pulse, V_{CM} , to assure that the output remains in HIGH state (i.e., $V_O > 15\text{ V}$ or $\overline{FAULT} > 2\text{ V}$).
29. Common mode transient immunity at output LOW state is the maximum positive tolerable dV_{cm}/dt on the leading edge of the common mode pulse, V_{CM} , to assure that the output remains in a LOW state (i.e., $V_O < 1.0\text{ V}$ or $\overline{FAULT} < 0.8\text{ V}$).

Typical Performance Characteristics

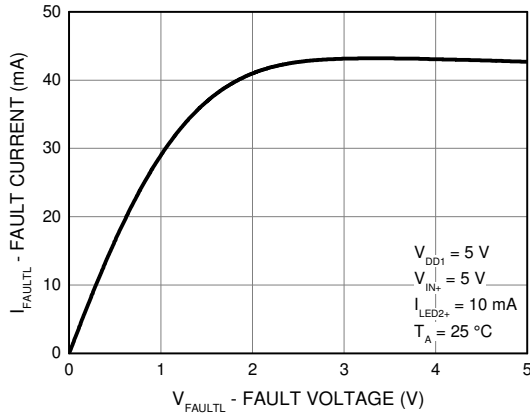

Figure 1. FAULT Logic Low Output Current (I_{FAULTL}) vs. FAULT Logic Low Output Voltage (V_{FAULTL})

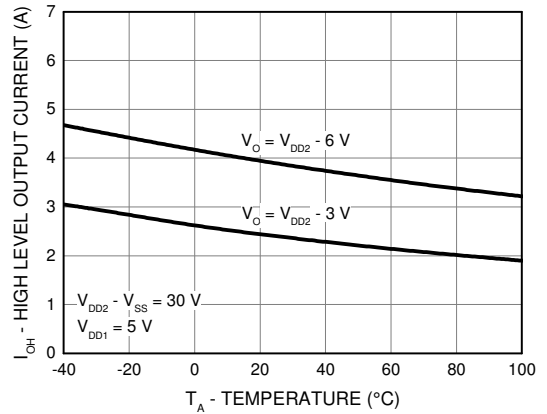

Figure 2. High Level Output Current (I_{OH}) vs. Temperature

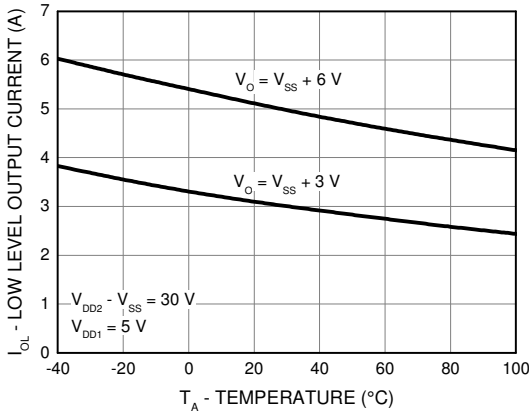

Figure 3. Low Level Output Current (I_{OL}) vs. Temperature

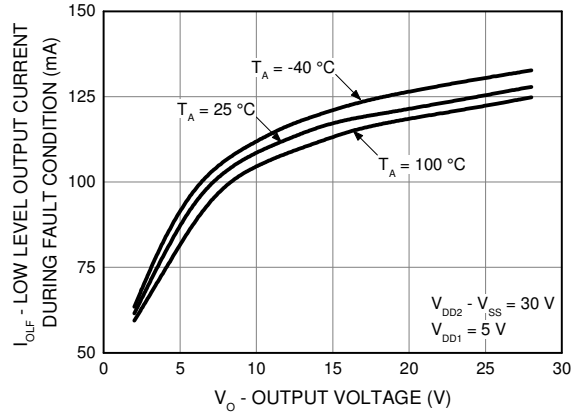

Figure 4. Low Level Output Current During Fault Condition (I_{OLF}) vs. Output Voltage (V_{O})

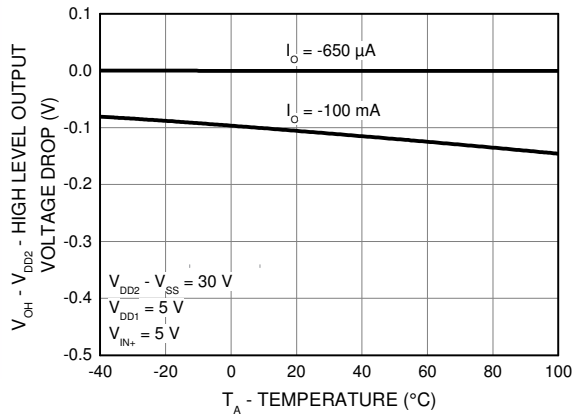

Figure 5. High Level Output Voltage Drop ($V_{\text{OH}} - V_{\text{DD}}$) vs. Temperature

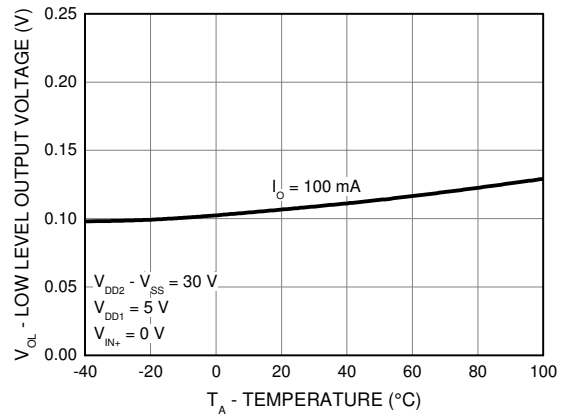

Figure 6. Low Level Output Voltage (V_{OL}) vs. Temperature

Typical Performance Characteristics (Continued)

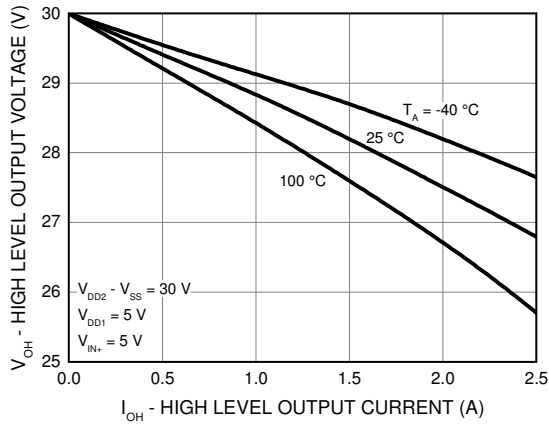

Figure 7. High Level Output Voltage (V_{OH}) vs. High Level Output Current (I_{OH})

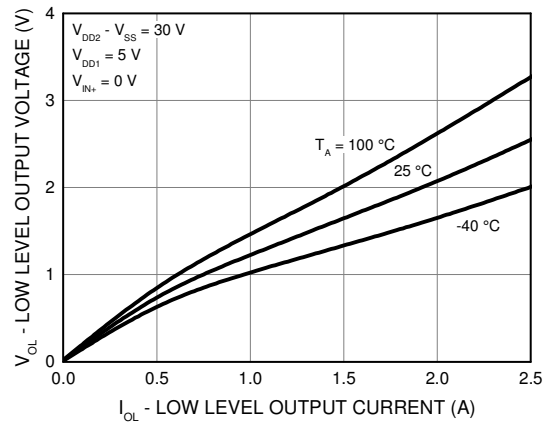

Figure 8. Low Level Output Voltage (V_{OL}) vs. Low Level Output Current (I_{OL})

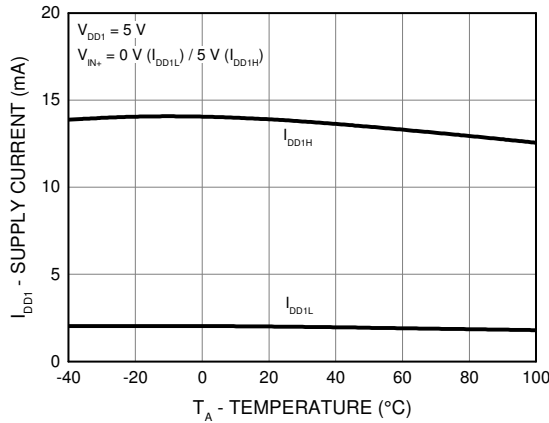

Figure 9. Supply Current (I_{DD1}) vs. Temperature

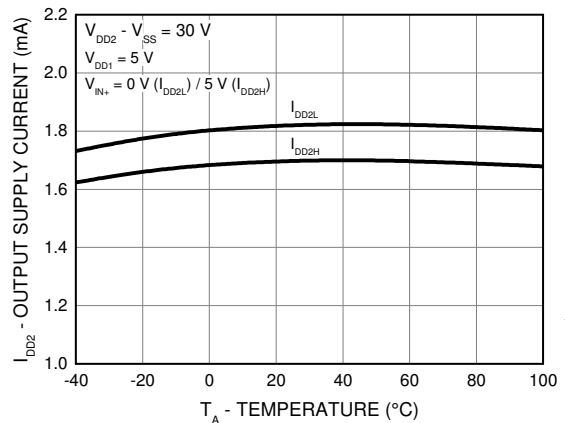

Figure 10. Output Supply Current (I_{DD2}) vs. Temperature

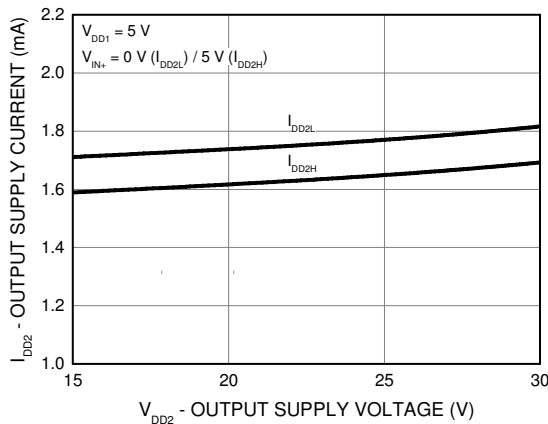

Figure 11. Output Supply Current (I_{DD2}) vs. Output Supply Voltage (V_{DD2})

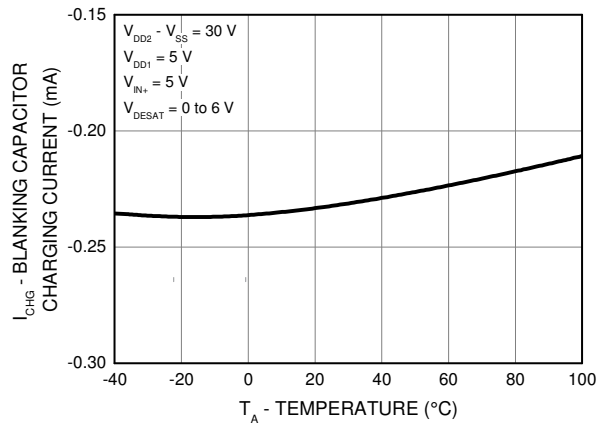

Figure 12. Blanking Capacitor Charge Current (I_{CHG}) vs. Temperature

Typical Performance Characteristics (Continued)

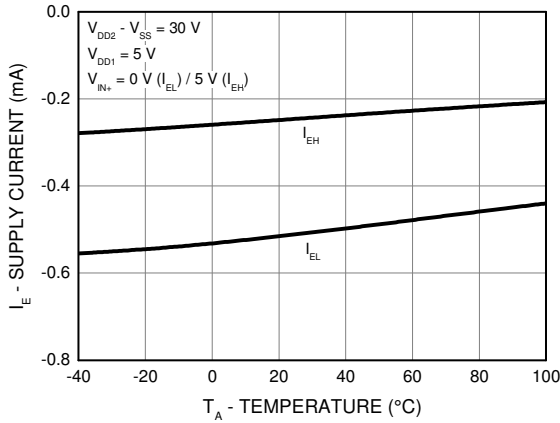

Figure 13. Supply Current (I_E) vs. Temperature

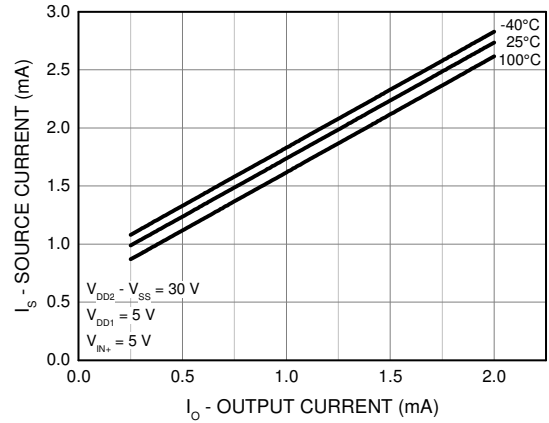

Figure 14. Source Current (I_S) vs. Output Current (I_O)

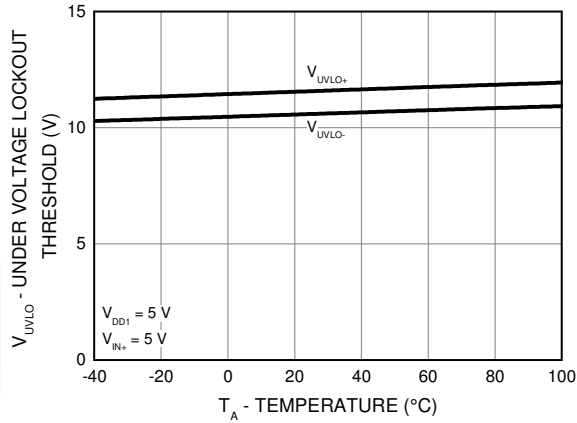

Figure 15. Under Voltage Lockout Threshold (V_{UVLO}) vs. Temperature

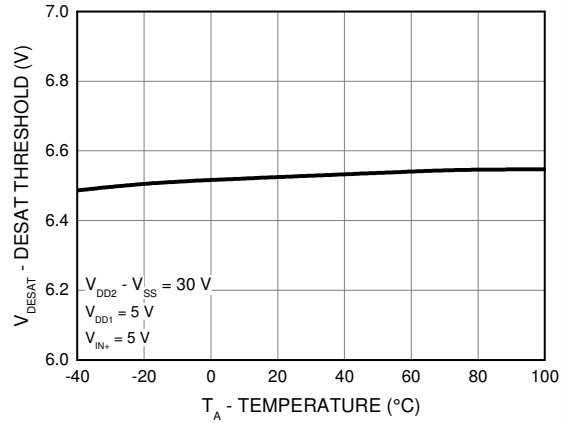

Figure 16. DESAT Threshold (V_{DESAT}) vs. Temperature

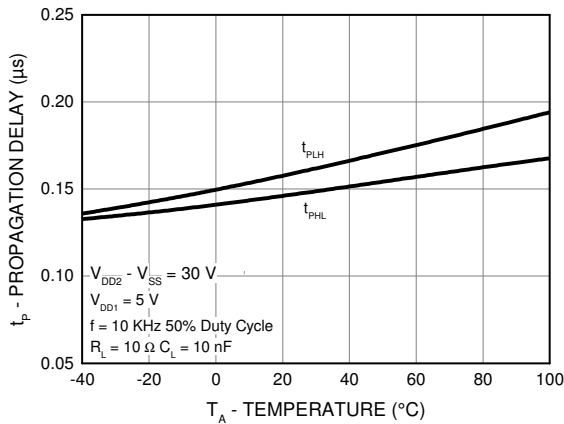

Figure 17. Propagation Delay (t_P) vs. Temperature

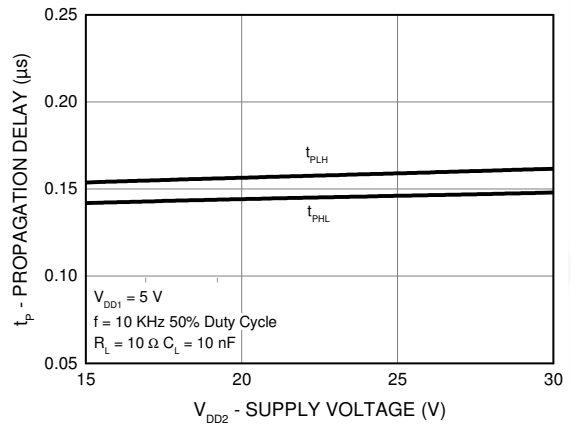

Figure 18. Propagation Delay (t_P) vs. Supply Voltage (V_{DD2})

Typical Performance Characteristics (Continued)

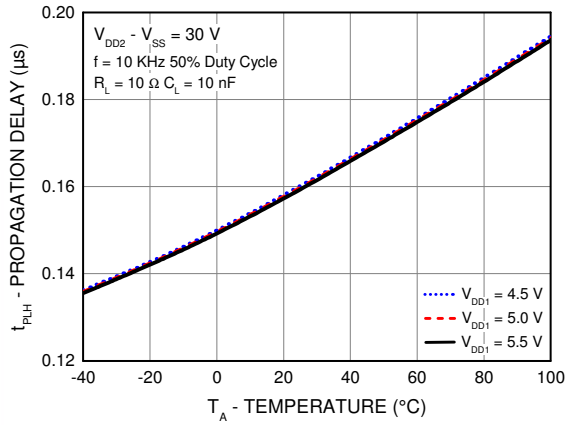

Figure 19. Propagation Delay Time to Logic High Output (t_{PLH}) vs. Temperature

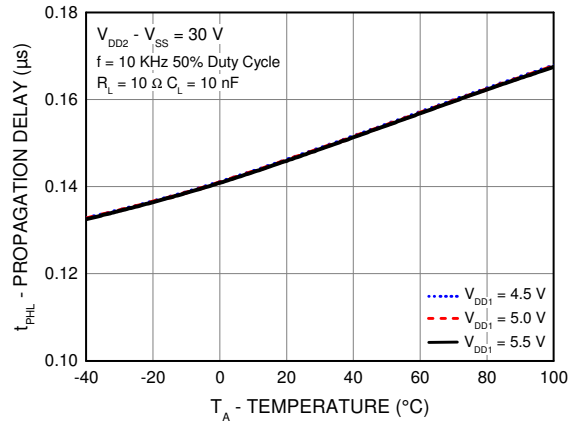

Figure 20. Propagation Delay Time to Logic Low Output (t_{PHL}) vs. Temperature

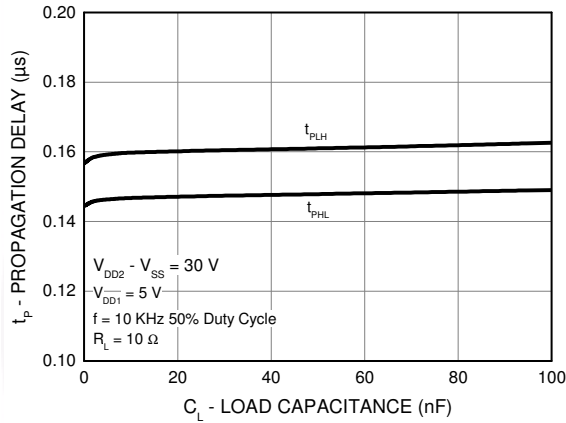

Figure 21. Propagation Delay (t_p) vs. Load Capacitance (C_L)

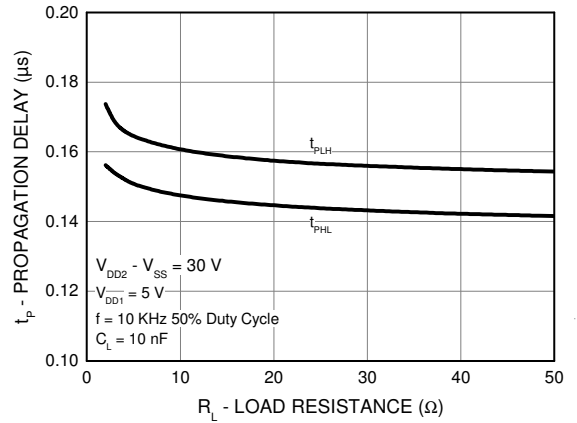

Figure 22. Propagation Delay (t_p) vs. Load Resistance (R_L)

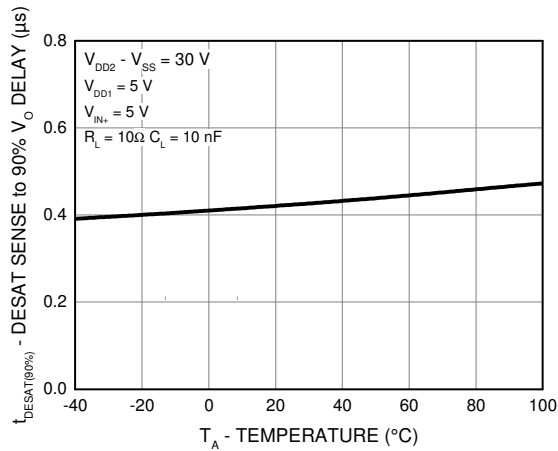

Figure 23. DESAT Sense to 90% V_O Delay ($t_{DESAT(90\%)}$) vs. Temperature

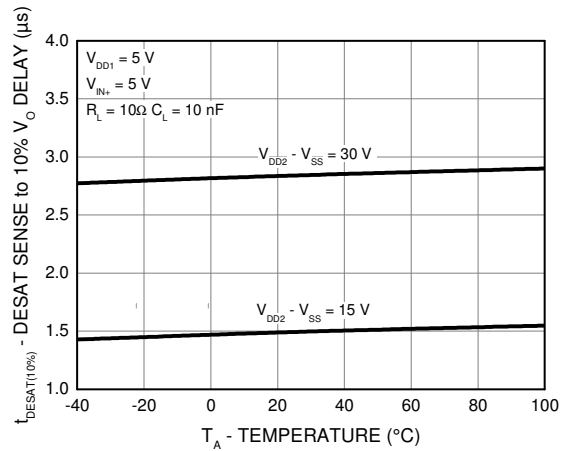

Figure 24. DESAT Sense to 10% V_O Delay ($t_{DESAT(10\%)}$) vs. Temperature

Typical Performance Characteristics (Continued)

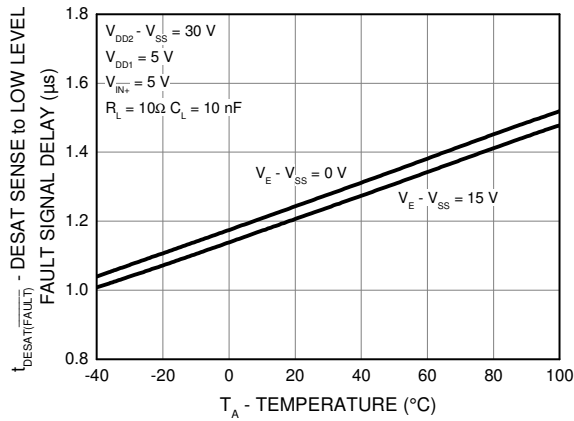

Figure 25. DESAT Sense to Low Level FAULT Signal Delay ($t_{\text{DESAT(FAULT)}}$) vs. Temperature

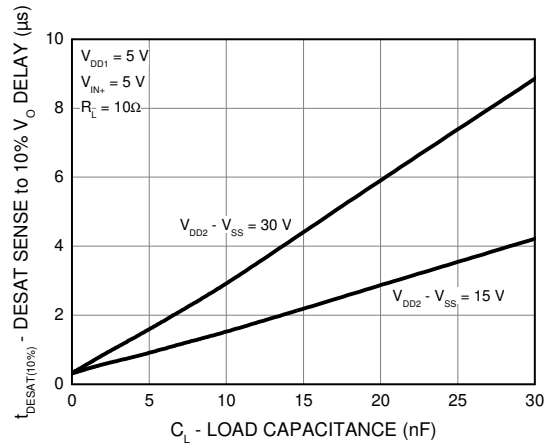

Figure 26. DESAT Sense to 10% V_O Delay ($t_{\text{DESAT(10%)}}$) vs. Load Capacitance (C_L)

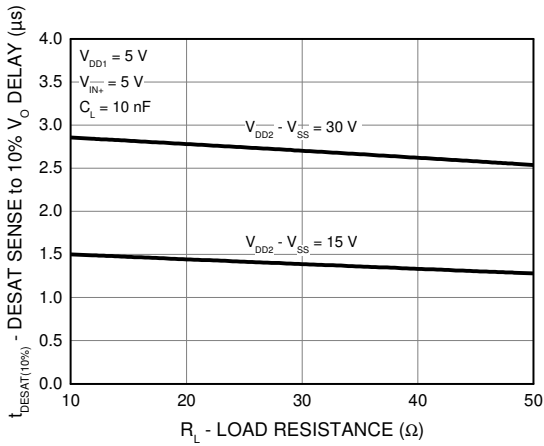

Figure 27. DESAT Sense to 10% V_O Delay ($t_{\text{DESAT(10%)}}$) vs. Load Resistance (R_L)

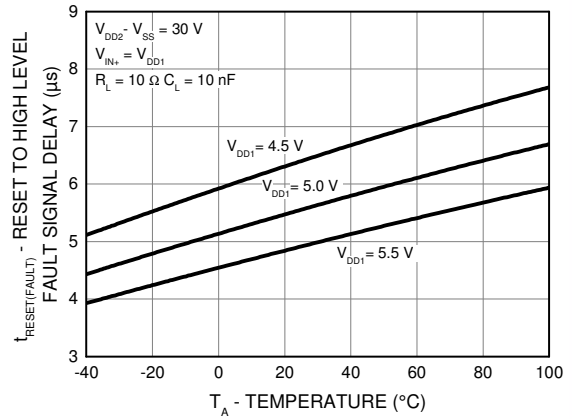

Figure 28. RESET to High Level FAULT Signal Delay ($t_{\text{RESET(FAULT)}}$) vs. Temperature

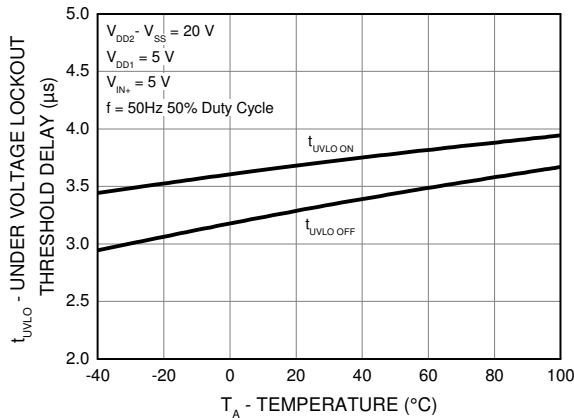

Figure 29. Under Voltage Lockout Threshold Delay (t_{UVLO}) vs. Temperature

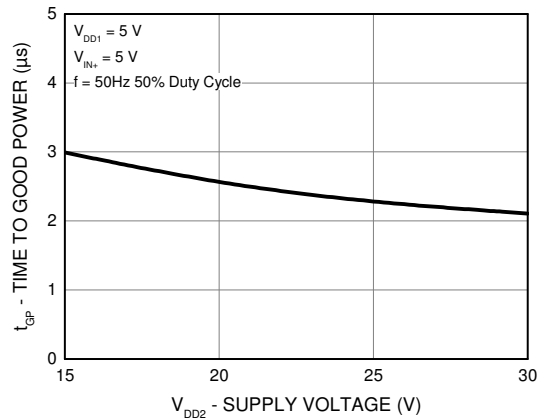

Figure 30. Time to Good Power (T_{GP}) vs. Supply Voltage (V_{DD2})

Typical Performance Characteristics (Continued)

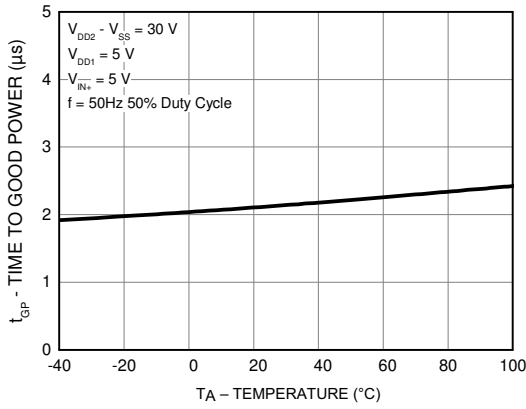

Figure 31. Time to Good Power (t_{GP}) vs. Temperature

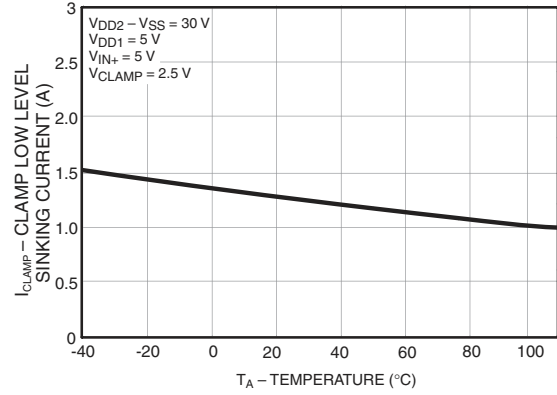

Figure 32. Clamp Low Level Sinking Current (I_{CLAMP}) vs. Temperature

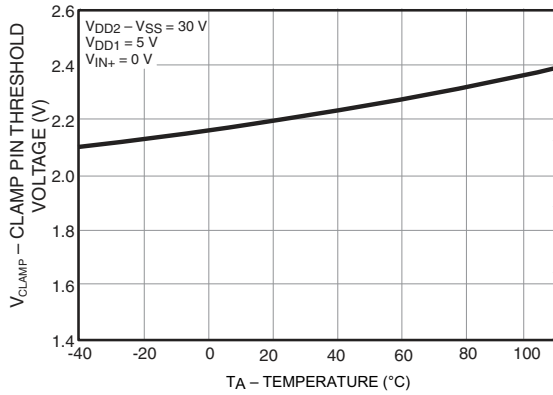

Figure 33. Clamping Threshold Voltage (V_{CLAMP}) vs. Temperature

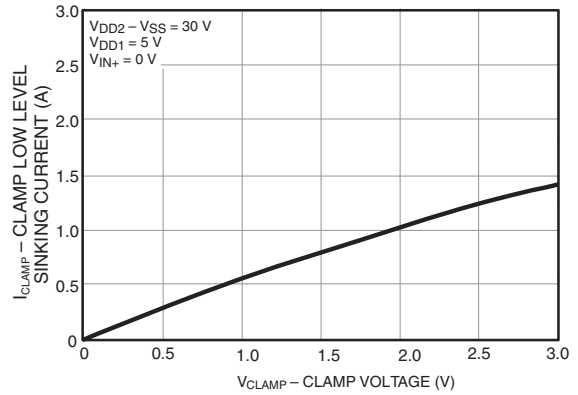

Figure 34. Clamp Low Level Sinking Current (I_{CLAMP}) vs. Clamp Voltage (V_{CLAMP})

Test Circuits

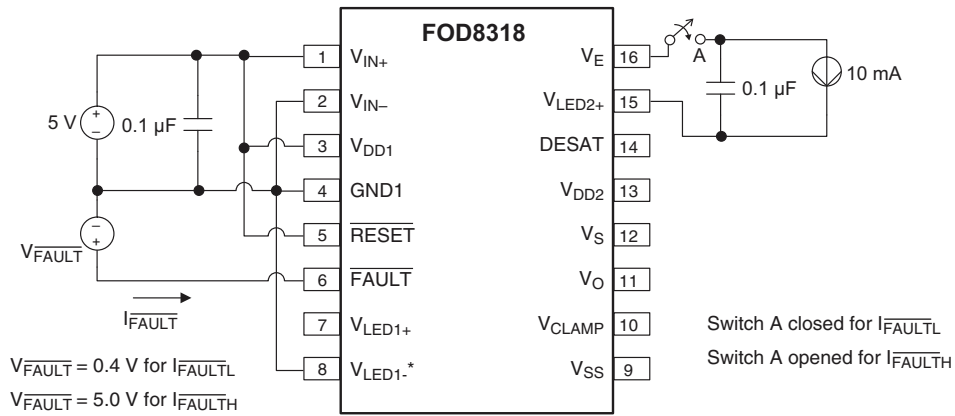

Figure 35. Fault Output Current ($I_{\overline{FAULTL}}$) and ($I_{\overline{FAULTH}}$) Test Circuit

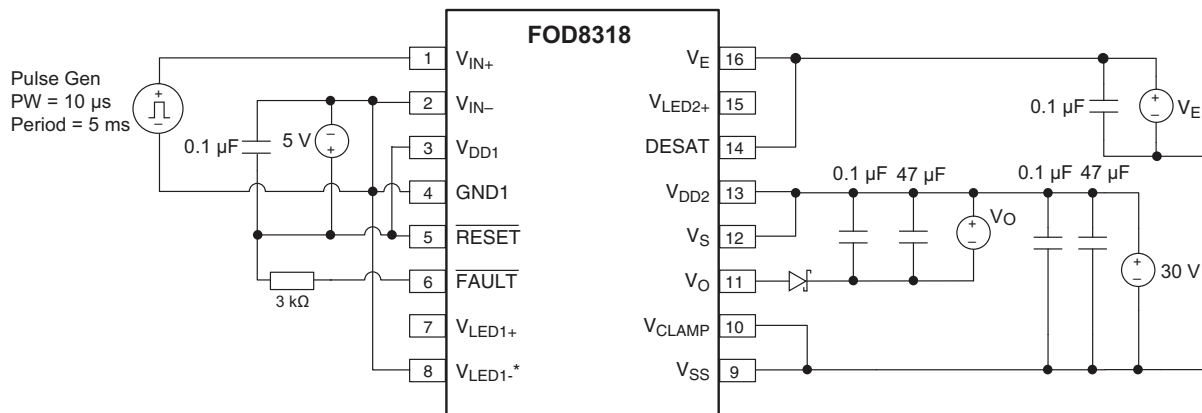

Figure 36. High Level Output Current (I_{OH}) Test Circuit

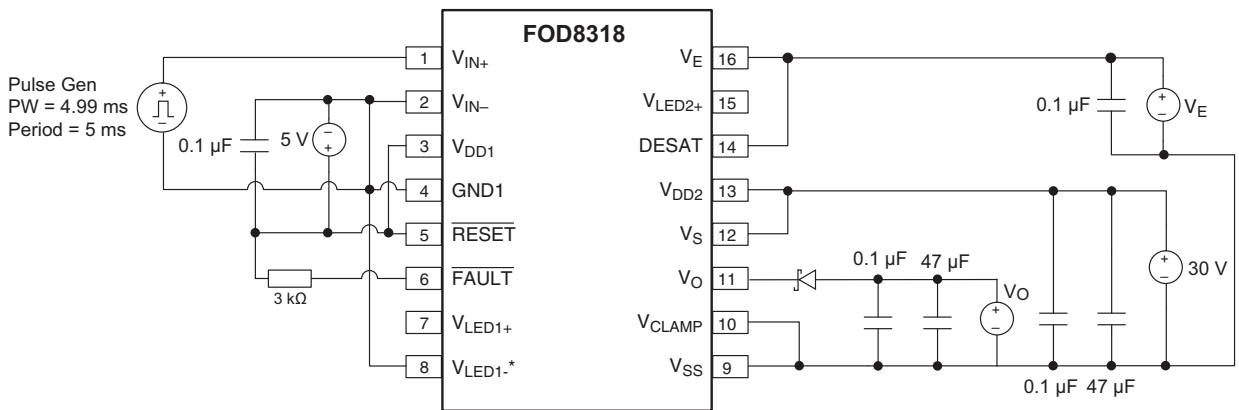

Figure 37. Low Level Output Current (I_{OL}) Test Circuit

Test Circuits (Continued)

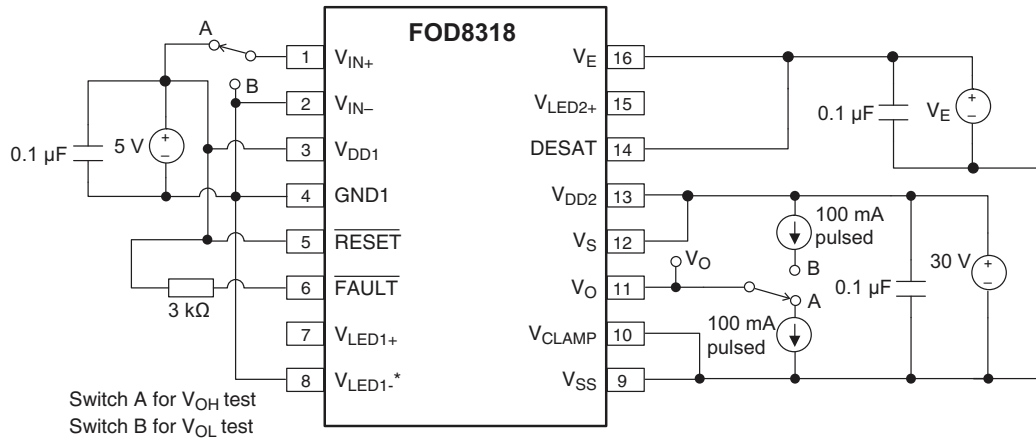

Figure 38. High Level (V_{OH}) and Low Level (V_{OL}) Output Voltage Test Circuit

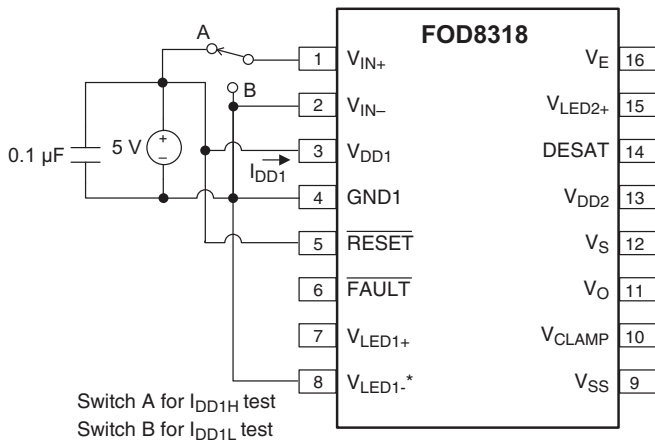

Figure 39. High Level (I_{DD1H}) and Low Level (I_{DD1L}) Supply Current Test Circuit

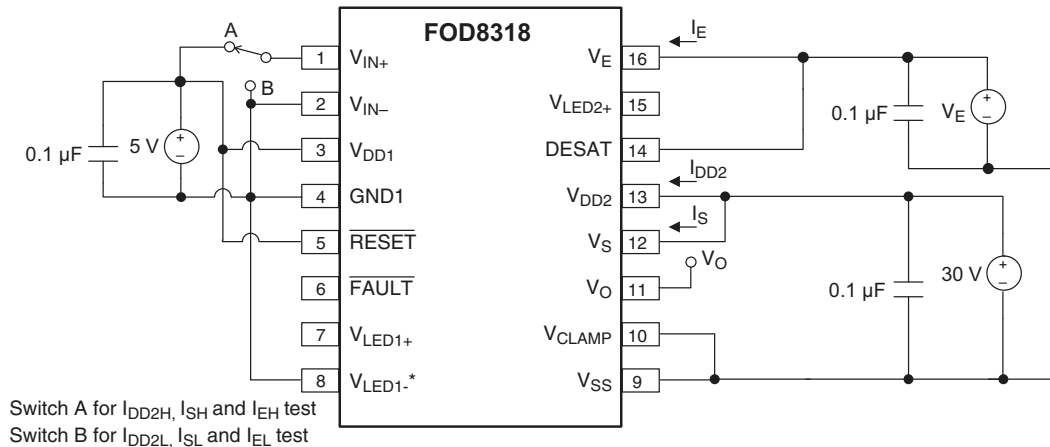

Figure 40. High Level (I_{DD2H}), Low Level (I_{DD2L}) Output Supply Current, High Level (I_{SH}), Low Level (I_{SL}) Source Current, V_E High Level (I_{EH}), and V_E Low Level (I_{EL}) Supply Current Test Circuit

Test Circuits (Continued)

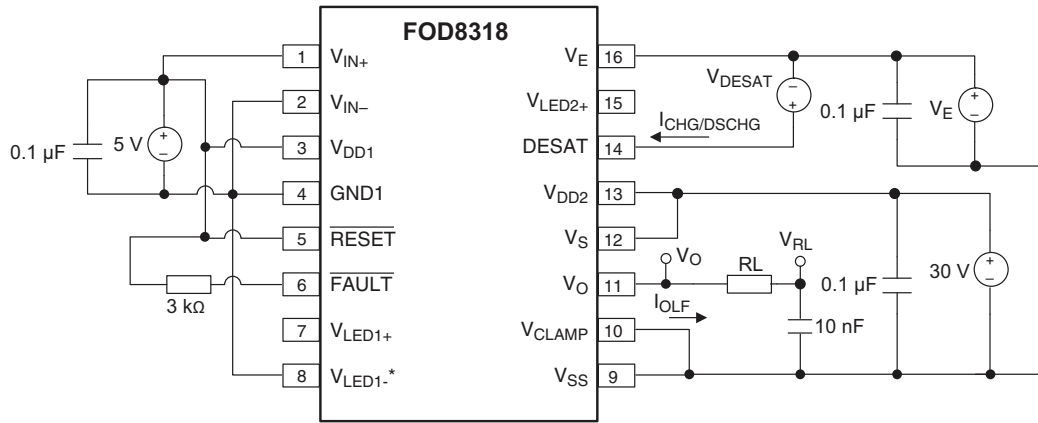

Figure 41. Low Level Output Current During Fault Conditions (I_{OLF}), Blanking Capacitor Charge Current (I_{CHG}), Blanking Capacitor Discharging Current (I_{DSCHG}), and DESAT Threshold (V_{DESAT}) Test Circuit

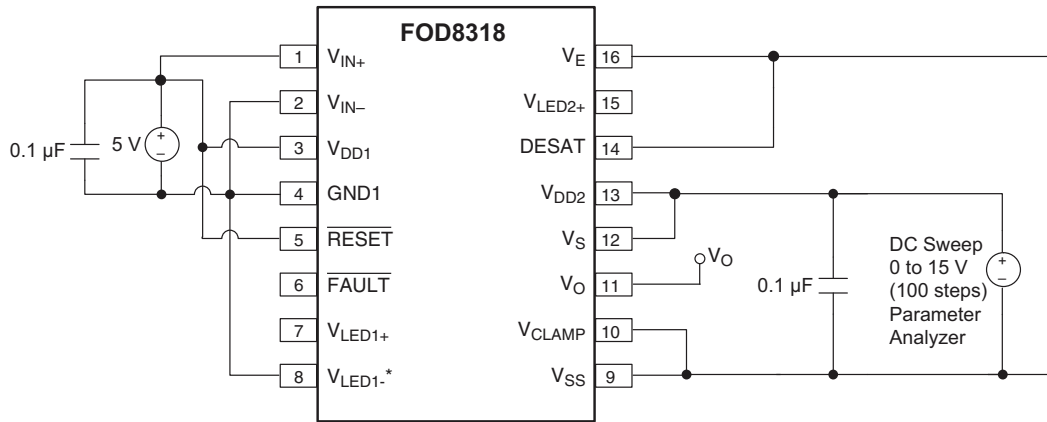

Figure 42. Under-Voltage Lockout Threshold (V_{UVLO}) Test Circuit

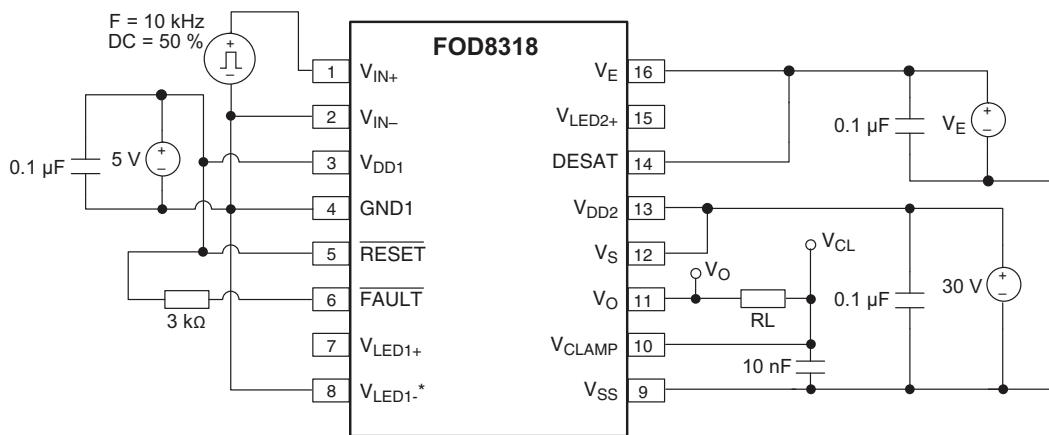

Figure 43. Propagation Delay (t_{PLH} , t_{PHL}), Pulse Width Distortion (PWD), Rise Time (t_r), and Fall Time (t_f) Test Circuit

Test Circuits (Continued)

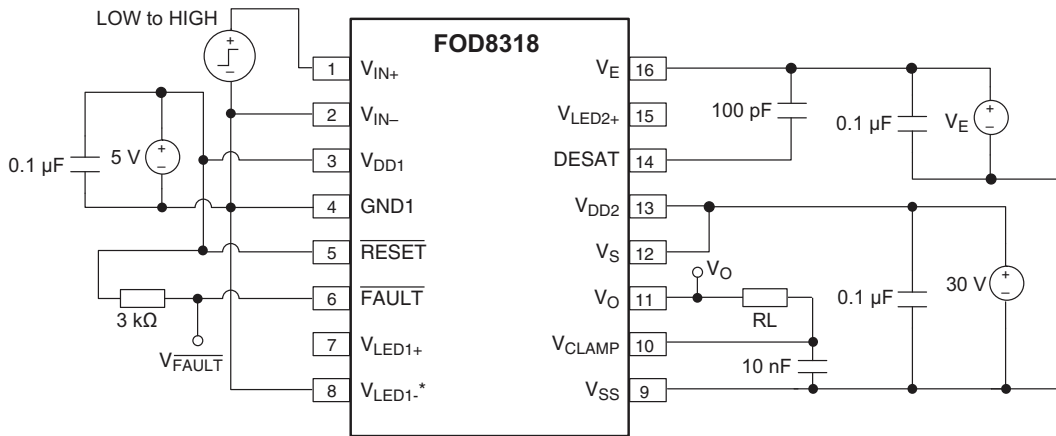

Figure 44. DESAT Sense ($t_{DESAT(90\%)}$, $t_{DESAT(10\%)}$), DESAT Fault ($t_{DESAT(\overline{FAULT})}$), and ($t_{DESAT(LOW)}$) Test Circuit

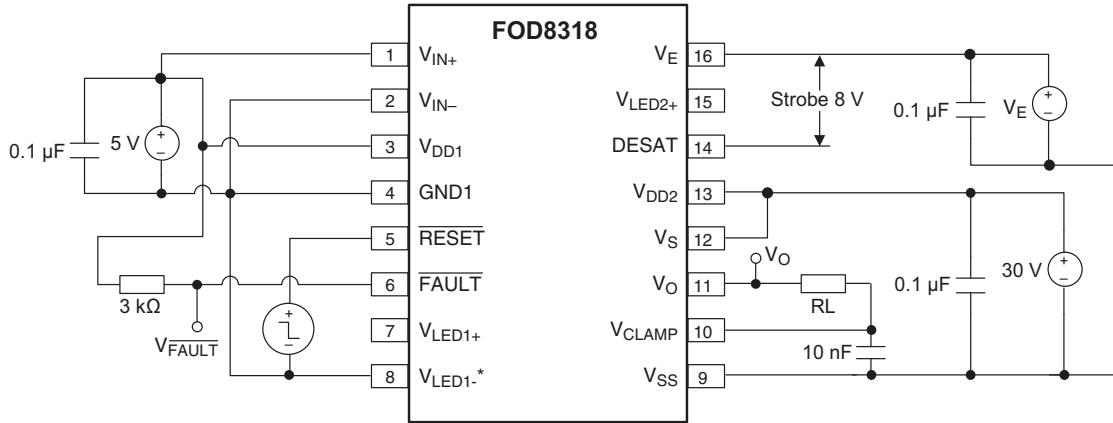

Figure 45. Reset Delay ($t_{RESET(\overline{FAULT})}$) Test Circuit

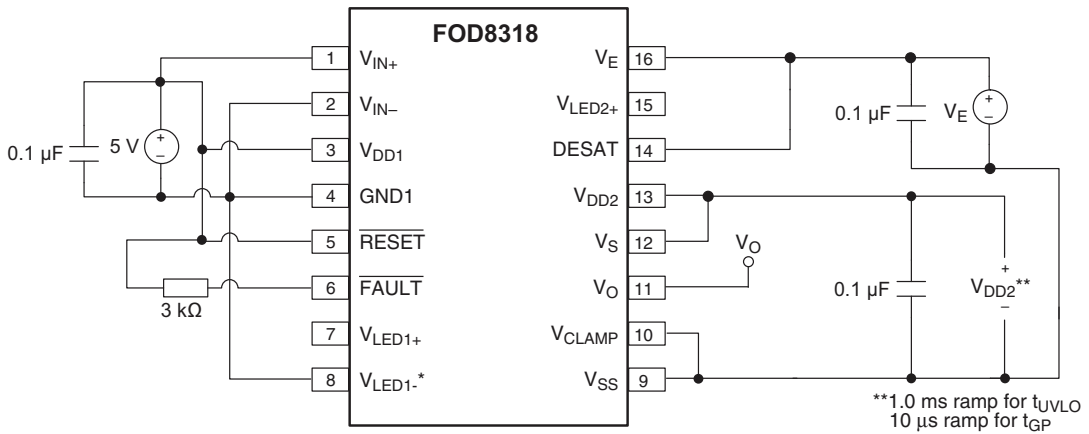

Figure 46. Under-Voltage Lockout Delay (t_{UVLO}) and Time to Good Power (t_{GP}) Test Circuit

Test Circuits (Continued)

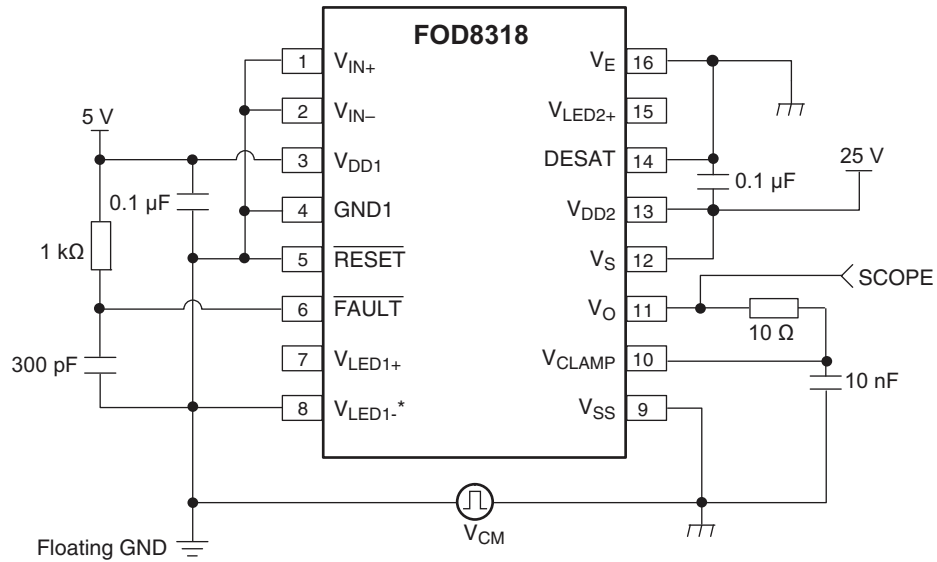

Figure 47. Common Mode Low (CM_L) Test Circuit at LED1 Off

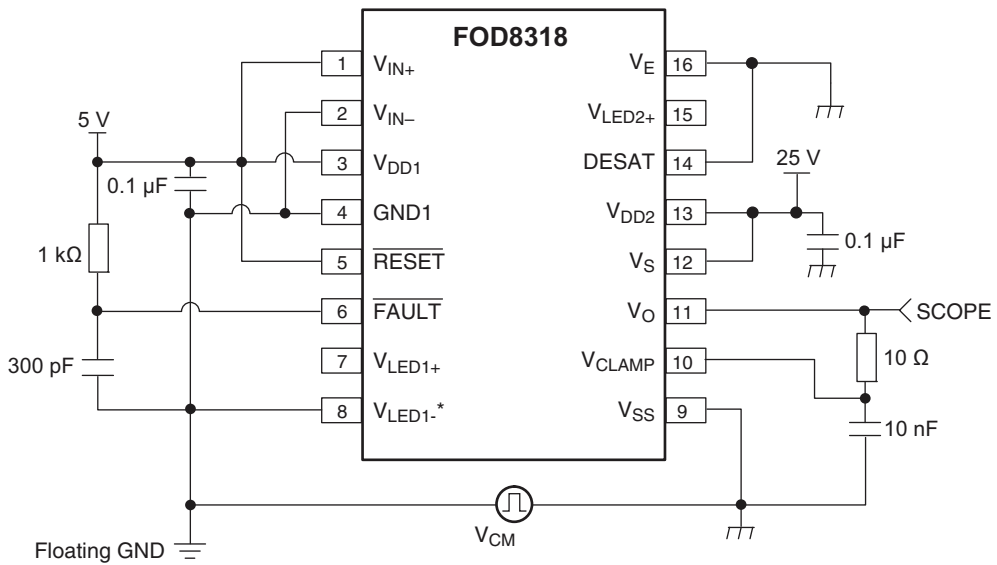

Figure 48. Common Mode High (CM_H) Test Circuit at LED1 On

Test Circuits (Continued)

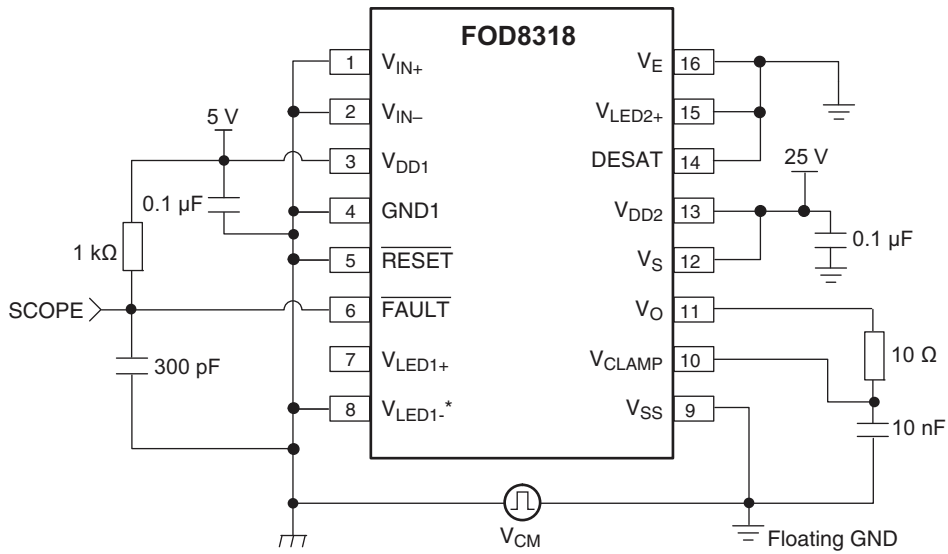

Figure 49. Common Mode High (CM_H) Test Circuit at LED2 Off

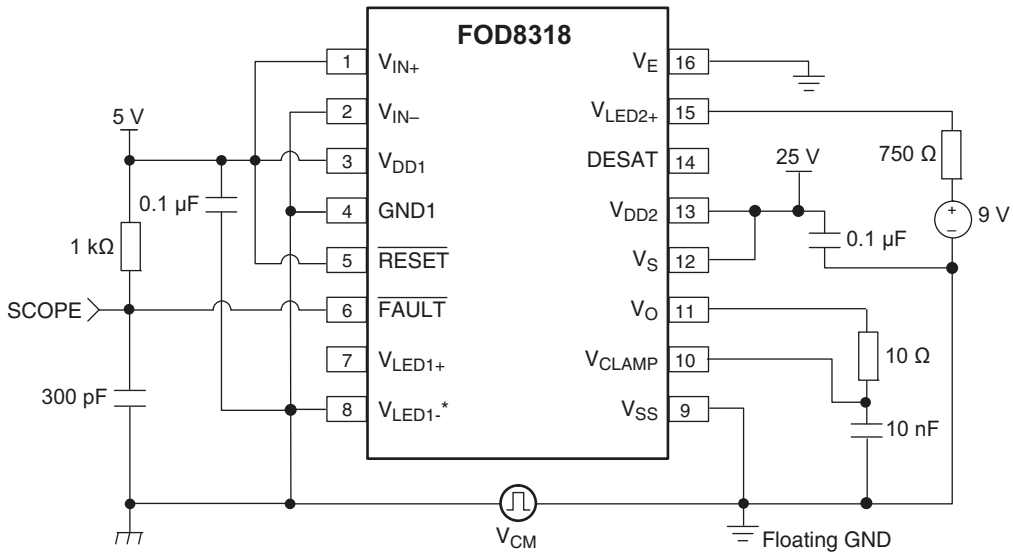

Figure 50. Common Mode Low (CM_L) Test Circuit at LED2 On

Test Circuits (Continued)

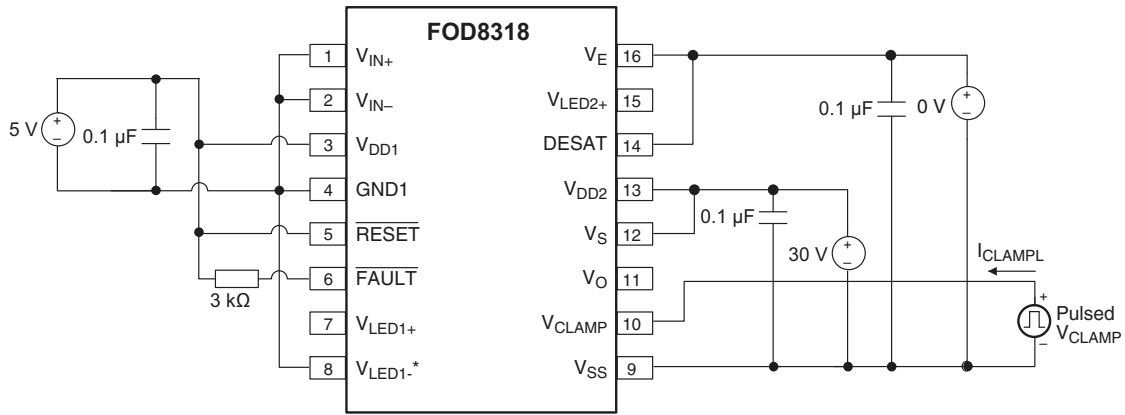
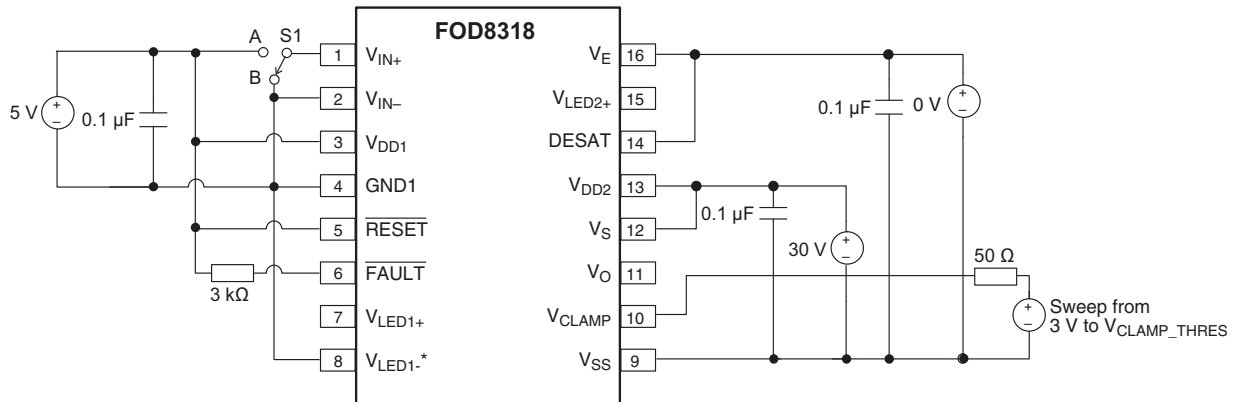

Figure 51. Clamp Low Level Sinking Current (I_{CLAMPL})



Initially set S1 to A before connecting 3 V to clamp pin. Then switch to B before sweeping down to get the V_{CLAMP_THRES} , clamping threshold voltage.

Figure 52. Clamp Pin Threshold Voltage (V_{CLAMP})

Timing Diagrams

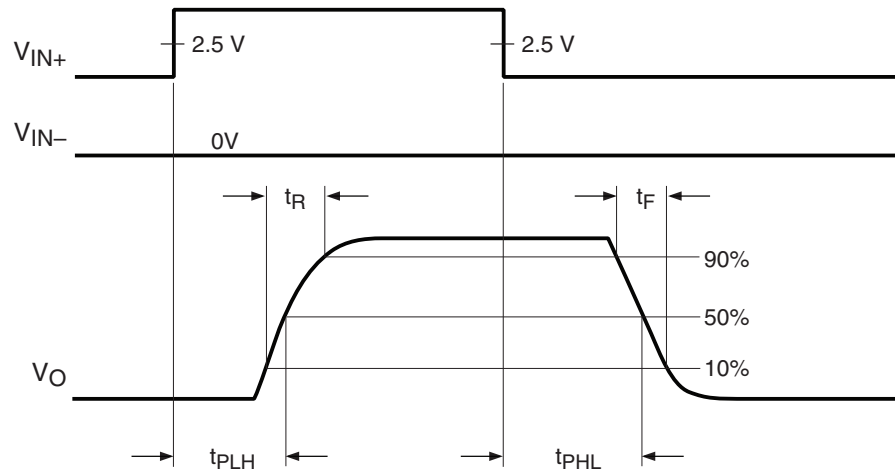

Figure 53. Propagation Delay (t_{PLH} , t_{PHL}), Rise Time (t_R), and Fall Time (t_F) Timing Diagram

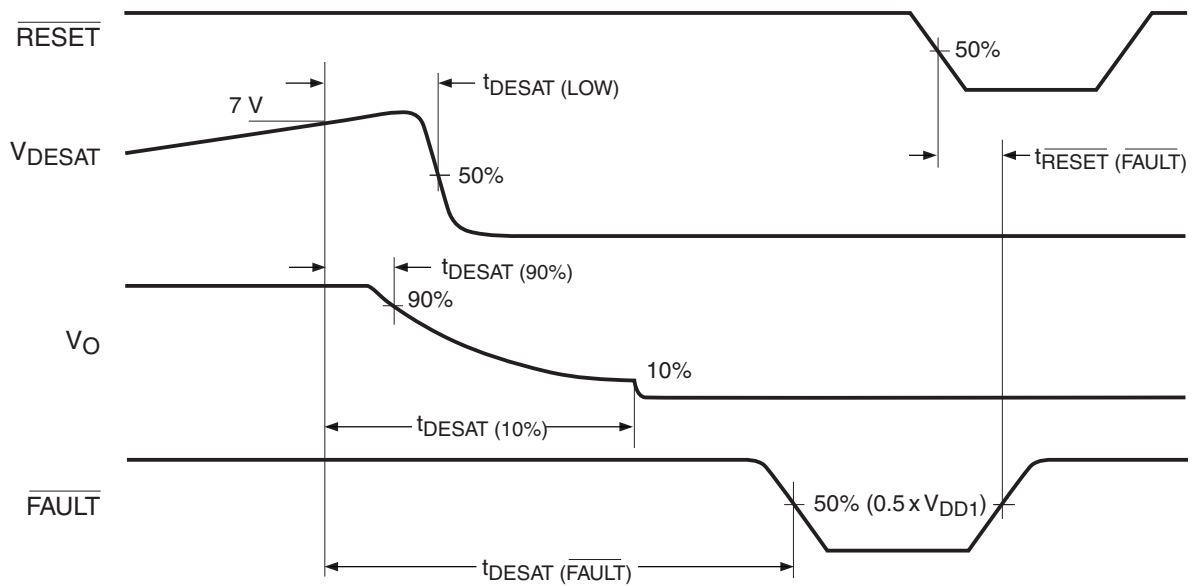

Figure 54. Definitions for Fault Reset Input (\overline{RESET}), Desaturation Voltage Input (DESAT), Output Voltage (V_O), and Fault Output (\overline{FAULT}) Timing Waveforms

Application Information

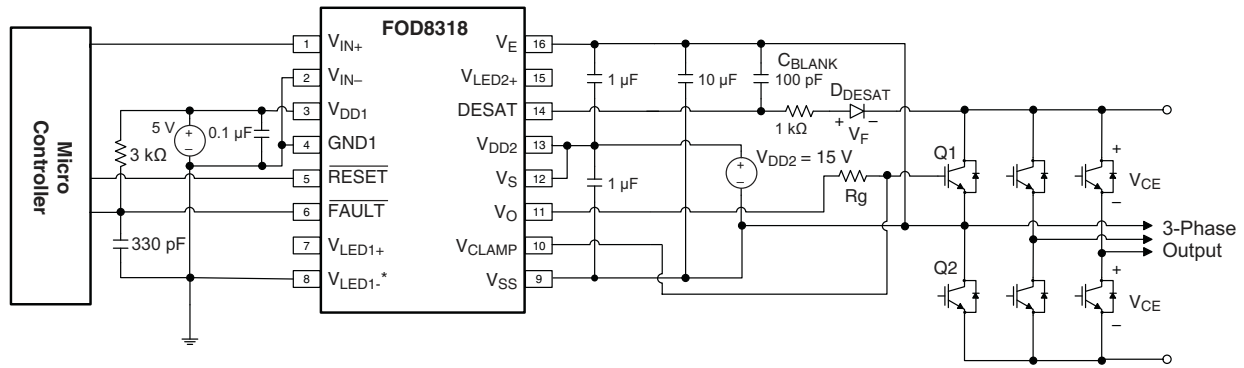

Figure 55. Recommended Application Circuit

Functional Description

The functional behavioral of FOD8318 is illustrated by the detailed internal schematic shown in Figure 56. This explains the interaction and sequence of internal and external signals, together with the timing diagrams.

1. Non-Inverting and Inverting Inputs

There are two CMOS/TTL-compatible inputs, V_{IN+} and V_{IN-} , to control the IGBT in non-inverting and inverting configurations, respectively. When V_{IN-} is set to LOW state, V_{IN+} controls the driver output, V_O , in non-inverting configuration. When V_{IN+} is set to HIGH state, V_{IN-} controls the driver output in inverting configuration.

The relationship between the inputs and output are illustrated in the Figure 57.

During normal operation, when no fault is detected, the $\overline{\text{FAULT}}$ output, which is an open-drain configuration, is latched to HIGH state. This allows the gate driver to be controlled by the input logic signal.

When a fault is detected, the $\overline{\text{FAULT}}$ output is latched to LOW state. This condition remains until the input logic is pulled to LOW and the $\overline{\text{RESET}}$ pin is also pulled LOW for a period longer than $PW_{\overline{\text{RESET}}}$.

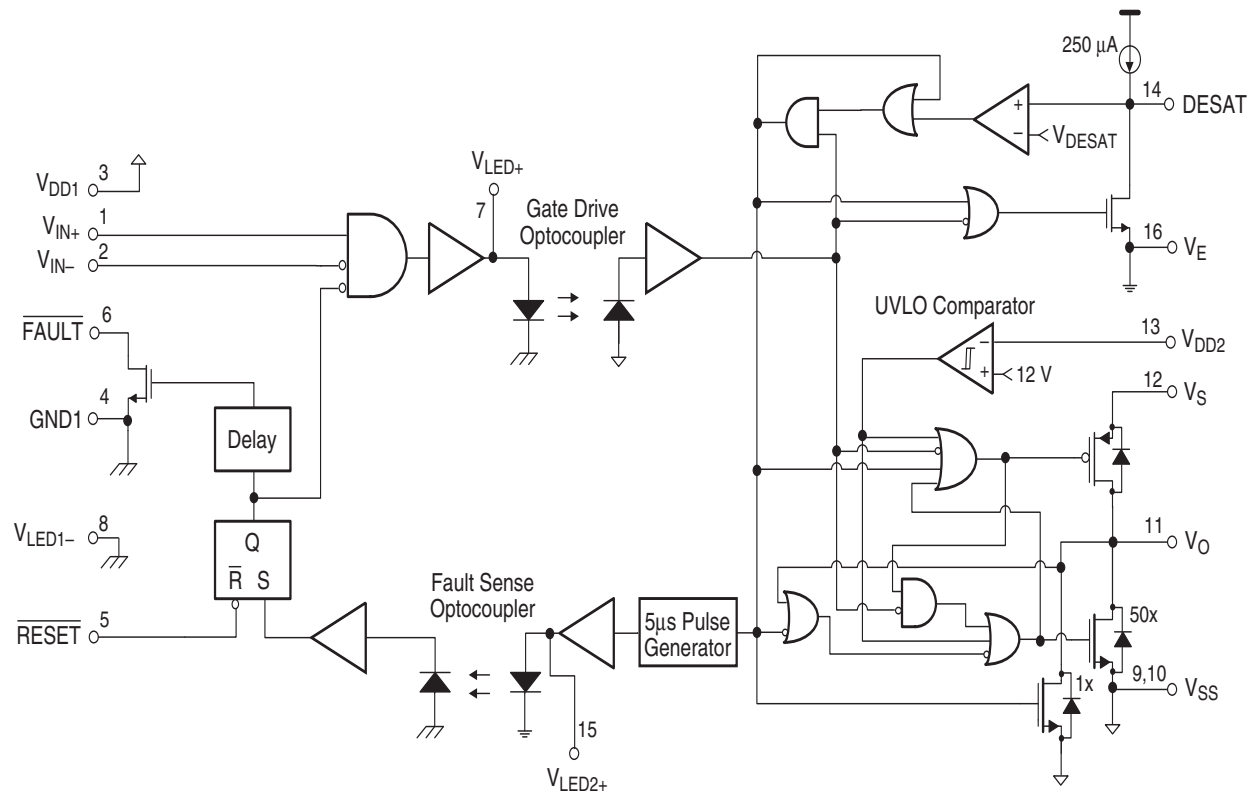

Figure 56. Detailed Internal Schematic

2. Gate Driver Output

A pair of PMOS and NMOS comprise the output driver stage, which facilitates close to rail-to-rail output swing. This feature allows a tight control of gate voltage during on-state and short-circuit condition. The output driver is typically to sink 2 A and source 2 A at room temperature. Due to the low $R_{DS(ON)}$ of the MOSFETs, the power dissipation is reduced as compared to those bipolar-type driver output stages. The absolute maximum rating of the output peak current, $I_{O(PEAK)}$, is 3 A; therefore the careful selection of the gate resistor, R_g , is required to limit the short-circuit current of the IGBT.

As shown in Figure 56, gate driver output is influenced by signals from the photodetector circuitry, the UVLO comparator, and the DESAT signals. Under no-fault condition, normal operation resumes while the supply voltage is above the UVLO threshold, the output of the photodetector drives the MOSFETs of the output stage.

The logic circuitry of the output stage ensures that the push-pull devices are never “ON” simultaneously. When the output of the photodetector is HIGH, the output, V_O , is pulled to HIGH state by turning on the PMOS. When the output of the photodetector is LOW, V_O is pulled to LOW state by turning on the NMOS.

When V_{DD2} supply goes below V_{UVLO} , which is the designated UVLO threshold at the comparator, V_O is pulled down to LOW state regardless of photodetector output.

When desaturation is detected, V_O turns off slowly as it is pulled LOW by the 1XNMOS device. The input to the fault sense circuitry is latched to HIGH state and turns on the LED. When V_O goes below 2 V, the 50XNMOS device turns on again, clamping the IGBT gate firmly to V_{SS} . The Fault Sense signal remains latched in the HIGH state until the LED of the gate driver circuitry turns off.

3. Desaturation Protection, FAULT Output

Desaturation detection protection ensures the protection of the IGBT at short-circuit by monitoring the collector-emitter voltage of the IGBT in the half bridge. When the DESAT voltage goes up and reaches above the threshold voltage, a short-circuit condition is detected and the driver output stage executes a “soft” IGBT turn-off and is eventually driven LOW, as illustrated in Figure 58. The FAULT open-drain output is triggered active LOW to report a desaturation error. It is only cleared by activating active LOW by the external controller to the \overline{RESET} input with the input logic is pulled to LOW.

The DESAT fault detector should be disabled for a short period (blanking time) before the IGBT turns on to allow the collector voltage to fall below DESAT threshold. This blanking period protects against false trigger of the DESAT while the IGBT is turning on.

The blanking time is controlled by the internal DESAT charge current, the DESAT voltage threshold, and the external DESAT capacitor (capacitor between DESAT and V_E pin). The nominal blanking time can be calcu-

lated using external capacitance (C_{BLANK}), FAULT threshold voltage (V_{DESAT}), and DESAT charge current (I_{CHG}) as:

$$t_{BLANK} = C_{BLANK} \times V_{DESAT} / I_{CHG}$$

With a recommended 100 pF DESAT capacitor, the nominal blanking time is:

$$100 \text{ pF} \times 7 \text{ V} / 250 \text{ } \mu\text{A} = 2.8 \text{ } \mu\text{s}$$

4. “Soft” Turn-Off

The soft turn-off feature ensures the safe turn off of the IGBT under fault conditions. This reduces the voltage spike on the collector of the IGBT. Without this, the IGBT would see a heavy spike on the collector and result in permanent damage to the device.

5. Under-Voltage Lockout

Under-voltage detection prevents the application of insufficient gate voltage to the IGBT. This could be dangerous, as it would drive the IGBT out of saturation and into the linear operation where the losses are very high and quickly overheated. This feature ensures the proper operating of the IGBTs. The output voltage, V_O , remains LOW regardless of the inputs as long as the supply voltage, $V_{DD2} - V_E$, is less than V_{UVLO+} . When the supply voltage falls below V_{UVLO-} , V_O goes LOW, as illustrated in Figure 59.

6. Active Miller Clamp Function

An active Miller clamp feature allows the sinking of the Miller current to the ground or emitter of the IGBT during a high-dV/dt situation. Instead of driving the IGBT gate to a negative supply voltage to increase the safety margin, the device has a dedicated V_{CLAMP} pin to control the Miller current. During turn-off, the gate voltage of the IGBT is monitored and the V_{CLAMP} output is activated when the gate voltage goes below 2 V (relative to V_{SS}). The Miller clamp NMOS transistor is then turned on and provides a low resistive path for the Miller current. This helps prevent a self-turn-on due to the parasitic Miller capacitor in power switches. The clamp voltage is $V_{OL} + 2.5 \text{ V}$ maximum for a Miller current up to 1200 mA. In this way, the V_{CLAMP} function does not affect the turn-off characteristic. It helps to clamp the gate to the LOW level throughout the turn-off time. During turn-on, where the input of the driver is activated, the V_{CLAMP} function is disabled or opened.

7. Time to Good Power

At initial power up, the LED is off and the output of the gate driver should be in the LOW state. Sometimes race conditions exist that causes the output to follow the V_E (assuming V_{DD2} and V_E are connected externally), until all of the circuits in the output IC have stabilized. This condition can result in output transitions or transients that are coupled to the driven IGBT. These glitches can cause the high-side and low-side IGBTs to conduct shoot-through current that may result in destructive damage to the power semiconductor devices. ON has introduced a initial turn-on delay, generally called “time-

to-good power". This delay, typically 2.5 μ s, is only present during the initial power-up of the device. Once powered, the "time-to-good power" delay is determined by the delay of the UVLO circuitry. If the LED is "ON" during

the initial turn-on activation, LOW-to-HIGH transition at the output of the gate driver only occurs 2.5 μ s after the V_{DD2} power is applied.

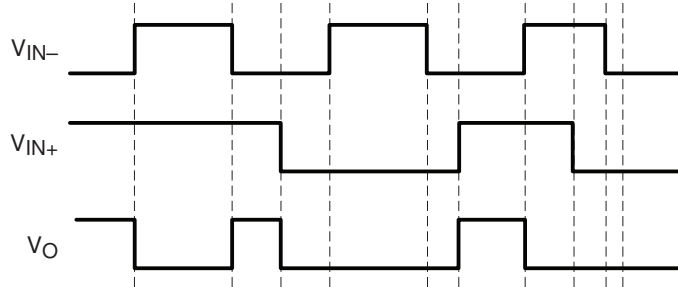

Figure 57. Input/Output Relationship

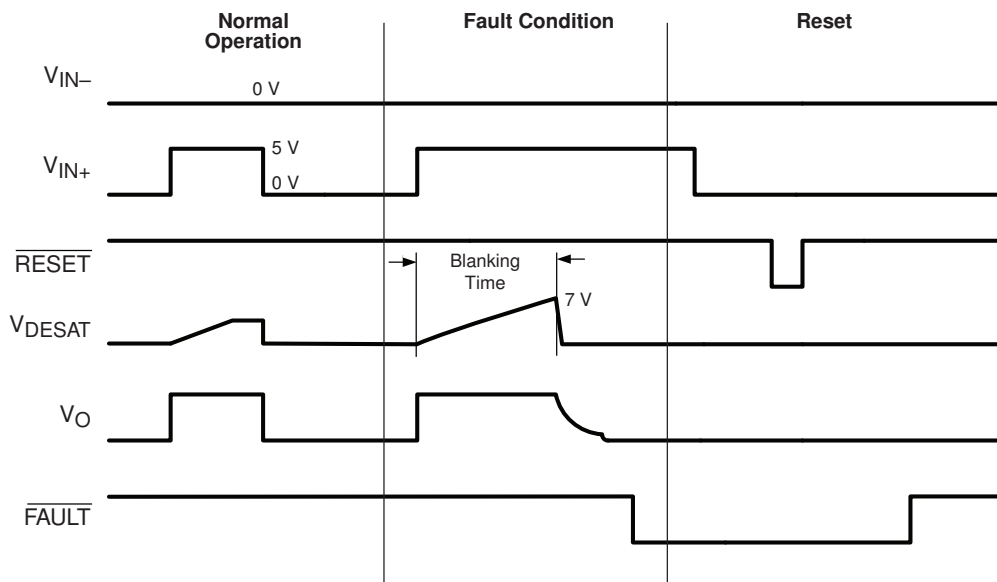

Figure 58. Timing Relationship Among DESAT, \overline{FAULT} , and \overline{RESET}

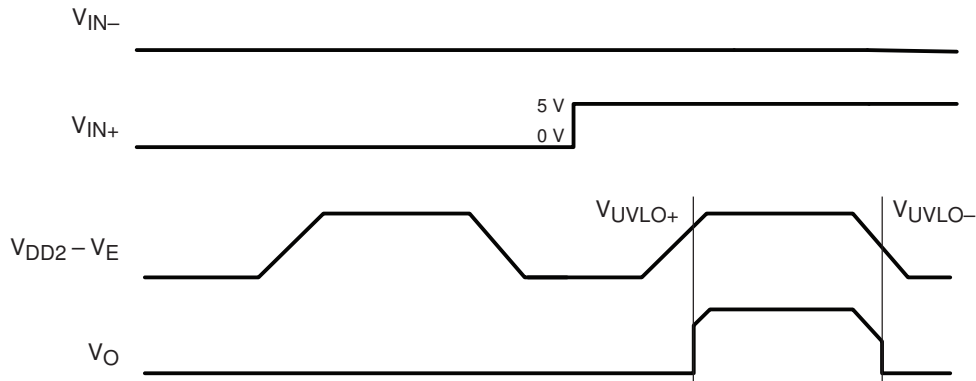



Figure 59. UVLO for Output Side

Ordering Information

Part Number	Package	Packing Method
FOD8318	SO 16-Pin	Tube (50 units per tube)
FOD8318R2	SO 16-Pin	Tape and Reel (750 units per reel)
FOD8318V	SO 16-Pin, DIN EN/IEC 60747-5-5 Option	Tube (50 units per tube)
FOD8318R2V	SO 16-Pin, DIN EN/IEC 60747-5-5 Option	Tape and Reel (750 units per reel)

 All packages are lead free per JEDEC: J-STD-020B standard.

Marking Information

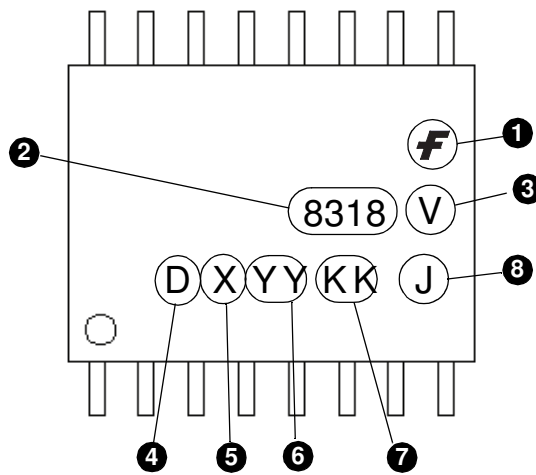

Definitions

1	Company logo
2	Device number, e.g., '8318' for FOD8318
3	DIN EN/IEC60747-5-5 option (only appears on component ordered with this option)
4	Plant code, e.g., 'D'
5	Last-digit year code, e.g., 'B' for 2011
6	Two-digit work week ranging from '01' to '53'
7	Lot traceability code
8	Package assembly code, J

Reflow Profile

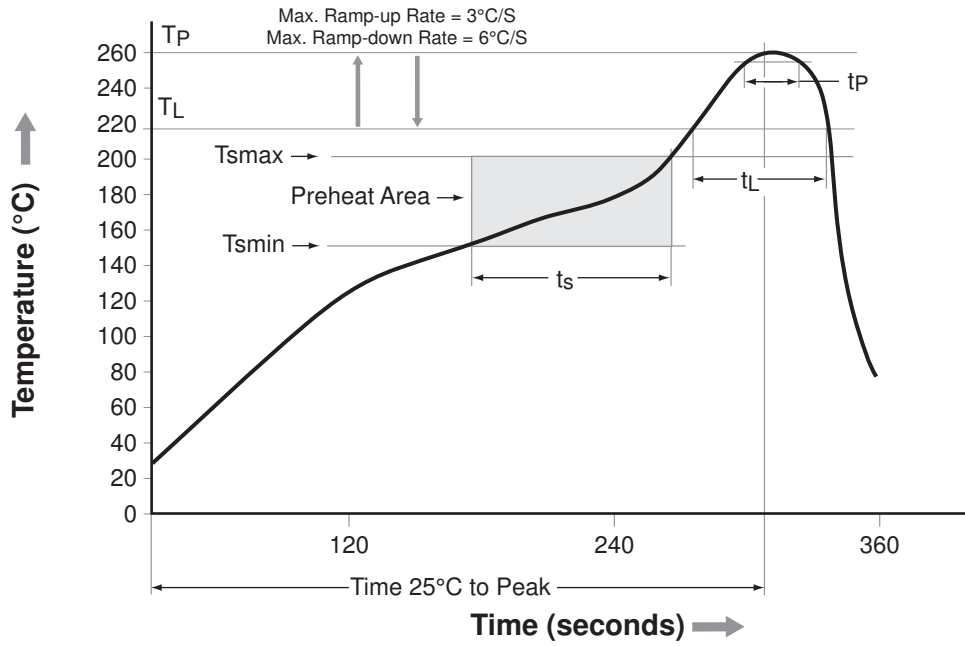

Profile Feature	Pb-Free Assembly Profile
Temperature Minimum (T_{smin})	150 °C
Temperature Maximum (T_{smax})	200 °C
Time (t_s) from (T_{smin} to T_{smax})	60–120 seconds
Ramp-up Rate (t_L to t_P)	3 °C/second max.
Liquidous Temperature (T_L)	217 °C
Time (t_L) Maintained Above (T_L)	60–150 seconds
Peak Body Package Temperature	260 °C +0 °C / –5 °C
Time (t_P) within 5 °C of 260 °C	30 seconds
Ramp-down Rate (T_P to T_L)	6 °C/second max.
Time 25 °C to Peak Temperature	8 minutes max.

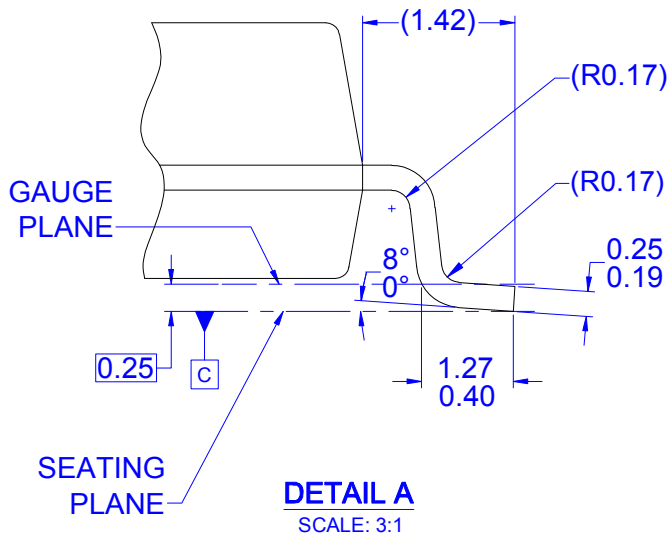
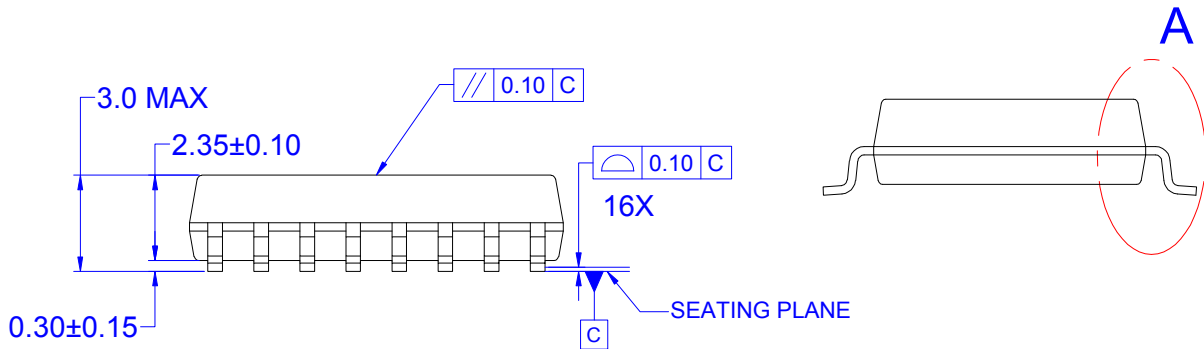
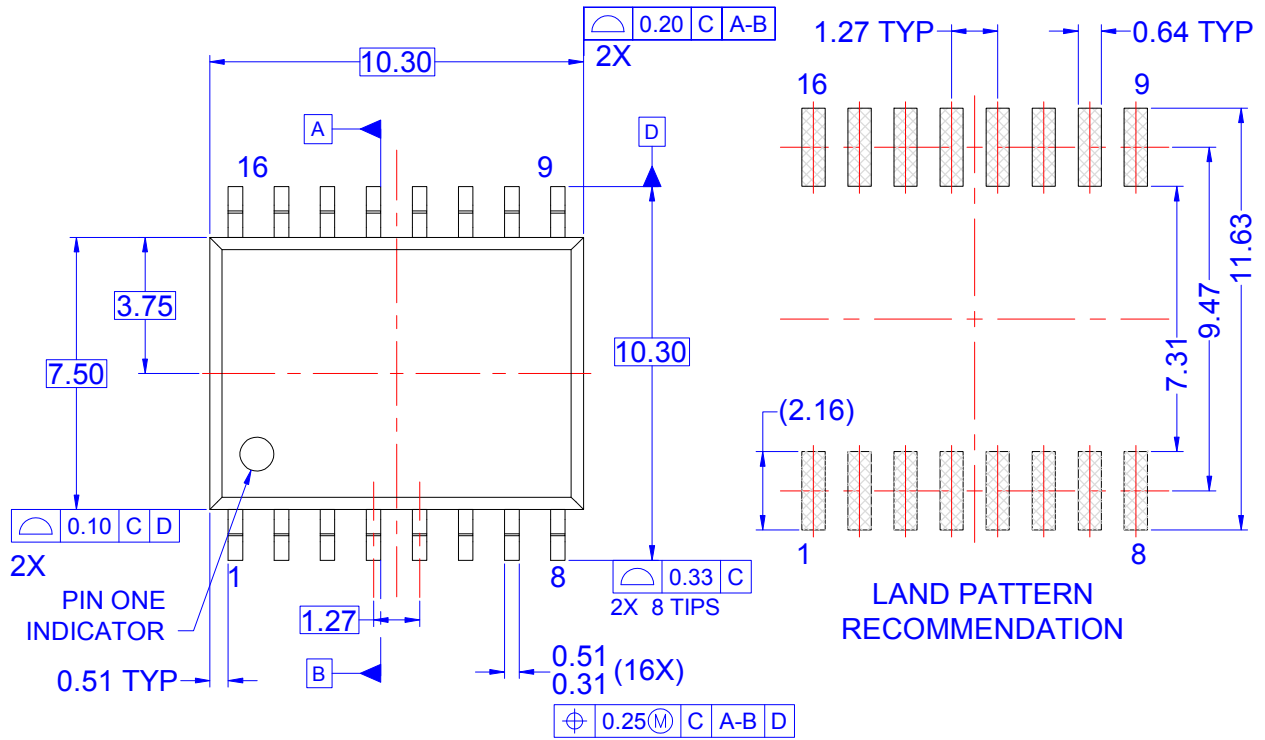

NOTES: UNLESS OTHERWISE SPECIFIED

- A) DRAWING REFERS TO JEDEC MS-013, VARIATION AA.
- B) ALL DIMENSIONS ARE IN MILLIMETERS.
- C) DIMENSIONS ARE EXCLUSIVE OF BURRS, MOLD FLASH AND TIE BAR PROTRUSIONS
- D) DRAWING CONFORMS TO ASME Y14.5M-1994
- E) LAND PATTERN STANDARD: SOIC127P1030X275-16N
- F) DRAWING FILE NAME: MKT-M16FREV2

ON Semiconductor and  are trademarks of Semiconductor Components Industries, LLC dba ON Semiconductor or its subsidiaries in the United States and/or other countries. ON Semiconductor owns the rights to a number of patents, trademarks, copyrights, trade secrets, and other intellectual property. A listing of ON Semiconductor's product/patent coverage may be accessed at www.onsemi.com/site/pdf/Patent-Marking.pdf. ON Semiconductor reserves the right to make changes without further notice to any products herein. ON Semiconductor makes no warranty, representation or guarantee regarding the suitability of its products for any particular purpose, nor does ON Semiconductor assume any liability arising out of the application or use of any product or circuit, and specifically disclaims any and all liability, including without limitation special, consequential or incidental damages. Buyer is responsible for its products and applications using ON Semiconductor products, including compliance with all laws, regulations and safety requirements or standards, regardless of any support or applications information provided by ON Semiconductor. "Typical" parameters which may be provided in ON Semiconductor data sheets and/or specifications can and do vary in different applications and actual performance may vary over time. All operating parameters, including "Typicals" must be validated for each customer application by customer's technical experts. ON Semiconductor does not convey any license under its patent rights nor the rights of others. ON Semiconductor products are not designed, intended, or authorized for use as a critical component in life support systems or any FDA Class 3 medical devices or medical devices with a same or similar classification in a foreign jurisdiction or any devices intended for implantation in the human body. Should Buyer purchase or use ON Semiconductor products for any such unintended or unauthorized application, Buyer shall indemnify and hold ON Semiconductor and its officers, employees, subsidiaries, affiliates, and distributors harmless against all claims, costs, damages, and expenses, and reasonable attorney fees arising out of, directly or indirectly, any claim of personal injury or death associated with such unintended or unauthorized use, even if such claim alleges that ON Semiconductor was negligent regarding the design or manufacture of the part. ON Semiconductor is an Equal Opportunity/Affirmative Action Employer. This literature is subject to all applicable copyright laws and is not for resale in any manner.

PUBLICATION ORDERING INFORMATION

LITERATURE FULFILLMENT:

Literature Distribution Center for ON Semiconductor
19521 E. 32nd Pkwy, Aurora, Colorado 80011 USA
Phone: 303-675-2175 or 800-344-3860 Toll Free USA/Canada
Fax: 303-675-2176 or 800-344-3867 Toll Free USA/Canada
Email: orderlit@onsemi.com

N. American Technical Support: 800-282-9855 Toll Free
USA/Canada
Europe, Middle East and Africa Technical Support:
Phone: 421 33 790 2910
Japan Customer Focus Center
Phone: 81-3-5817-1050

ON Semiconductor Website: www.onsemi.com
Order Literature: <http://www.onsemi.com/orderlit>
For additional information, please contact your local
Sales Representative