

H-bridge motor driver for automotive DC motor driving

Datasheet - production data

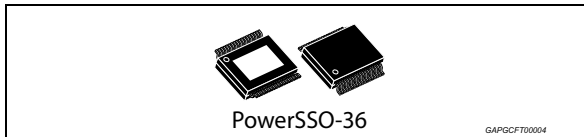

Features

Type	$R_{DS(on)}$	I_{out}	V_{CCmax}
VNHD7008AY	8 m Ω typ (per channel)	51 A	38 V

- AEC-Q100 qualified
- Output current: 51 A
- Dual fully protected HSD with MultiSense feedback
- Two integrated drivers for the external LSDs
- 3 V CMOS compatible inputs
- Protections:
 - Undervoltage shutdown
 - Overvoltage clamp
 - Thermal shutdown
 - Load current limitation
 - Self-limiting of fast thermal transients (Power Limitation)
 - Cross current protection
 - Shoot through protection
 - Loss of ground and loss of V_{CC}
 - Electrostatic discharge protection
 - Drain and source voltage monitoring of the external power MOSFETs, configurable via an external resistance (short-to-battery protection)
- PWM operation up to 20 kHz for external LSDs
- MultiSense monitoring functions
 - Analog motor current feedback
 - Chip temperature monitoring
 - Battery voltage monitoring



- MultiSense diagnostic functions
 - Output short to ground detection
 - Thermal shutdown indication
 - OFF-state open-load detection
 - Output short to V_{CC} detection
- Standby mode
- Half bridge operation
- Charge pump output for reverse battery protection
- Package: ECOPACK

Description

The device is a DC motor driver for automotive applications. It integrates a full protected dual high-side driver and the drivers and protections for the two external power MOSFETs in low-side configuration.

The device is designed using STMicroelectronics well known and proven proprietary VIPower[®] M0 technology that allows to efficiently integrate on the same die a true PowerMOSFET with an intelligent signal/ protection circuitry. The device is housed in a PowerSSO-36 exposed pad package to optimize the dissipation performances.

The input signals IN_A and IN_B can directly interface the microcontroller to select the motor direction and the brake conditions. Two selection pins (SEL0 and SEL1) are available to address to the microcontroller the information available on the MultiSense. The MultiSense pin allows to monitor the motor current, provides a voltage proportional to the battery value and the information on the temperature of the chip. The integrated protections are: load current limitation, overload active power limitation (with latch-off), overtemperature shutdown (with latch-off) and cross current protection.

Contents

1	Block diagram and pin description	6
2	Electrical specifications	9
2.1	Absolute maximum ratings	9
2.2	Thermal data	10
2.3	Electrical characteristics	11
2.4	Waveforms	24
3	Protections	27
3.1	Power limitation (high-side driver)	27
3.2	Thermal shutdown	27
3.3	High-side current limitation	27
3.4	External PowerMOS low side VDS monitoring	27
4	Typical application schematic	28
5	MultiSense operation	29
5.1	MultiSense analog monitoring	29
5.2	Multisense diagnostics flag in fault conditions	29
6	VREG and Driver_LS Block	30
7	Reverse battery protection	30
8	Open-load detection in off-state	30
9	Immunity against transient electrical disturbances	31
10	Package and PCB thermal data	32
10.1	PowerSSO-36 thermal data	32
11	Package and packing information	36
11.1	PowerSSO-36 package information	36
11.2	PowerSSO-36 packing information	38

	11.3	PowerSSO-36 marking information	40
12		Order codes	41
13		Revision history	42

List of tables

Table 1.	Block description	6
Table 2.	Pin definitions and functions	8
Table 3.	Suggested connection for unused and not connected pins	8
Table 4.	Absolute maximum ratings	9
Table 5.	Thermal data	10
Table 6.	Power section	11
Table 7.	Logic inputs (IN_A , IN_B) ($V_{CC} = 7\text{ V up to } 28\text{ V; } -40\text{ }^\circ\text{C} < T_j < 150\text{ }^\circ\text{C}$)	12
Table 8.	HSD switching ($V_{CC} = 13\text{ V; RLOAD} = 1.1\ \Omega$)	13
Table 9.	Gate driver for external MOS parameters ($V_{CC} = 13\text{ V}$)	13
Table 10.	Protections and diagnostics ($7\text{ V} < V_{CC} < 18\text{ V; } -40\text{ }^\circ\text{C} < T_j < 150\text{ }^\circ\text{C}$).	13
Table 11.	MultiSense ($7\text{ V} < V_{CC} < 18\text{ V; } -40\text{ }^\circ\text{C} < T_j < 150\text{ }^\circ\text{C}$)	15
Table 12.	Operative condition - truth table	22
Table 13.	On-state fault conditions- truth table	22
Table 14.	Off-state — truth table	23
Table 15.	IISO 7637-2 - electrical transient conduction along supply line	31
Table 16.	PCB properties	33
Table 17.	Thermal parameters	34
Table 18.	PowerSSO-36 (exposed pad) package mechanical data	36
Table 19.	Device summary	41
Table 20.	Document revision history	42

List of figures

Figure 1.	Block diagram	6
Figure 2.	Configuration diagram (top view)	7
Figure 3.	Current and voltage conventions	9
Figure 4.	T_{DSTKON}	18
Figure 5.	Definition of the low-side switching times	19
Figure 6.	Definition of the high-side switching times	19
Figure 7.	Low-side turn-on delay time	20
Figure 8.	Input reset time for HSD-fault unlatch.	20
Figure 9.	Input reset time for LSD-fault unlatch	21
Figure 10.	OFF-state diagnostic delay time from rising edge of VOUT (t_{D_VOL})	21
Figure 11.	Normal operative conditions (resistive load).	24
Figure 12.	Out shorted to ground and short clearing	25
Figure 13.	OUT shorted to Vcc and short clearing.	26
Figure 14.	Gate driver low side rise time normalized vs $C_g = 4.7nF$	26
Figure 15.	Gate driver low side fall time normalized vs $C_g = 4.7nF$	26
Figure 16.	Typical application schematic.	28
Figure 17.	MultiSense block diagram.	29
Figure 18.	PowerSSO-36 PCB board	32
Figure 19.	$R_{thj-amb}$ vs PCB copper area in open box free air condition	33
Figure 20.	Thermal fitting model of a double-channel HSD in PowerSSO-36	34
Figure 21.	Thermal impedance junction ambient single pulse.	34
Figure 22.	PowerSSO-36 package dimensions	36
Figure 23.	PowerSSO-36 tube shipment (no suffix)	38
Figure 24.	PowerSSO-36 tape and reel shipment (suffix "TR")	39
Figure 25.	PowerSSO-36 marking information	40

1 Block diagram and pin description

Figure 1. Block diagram

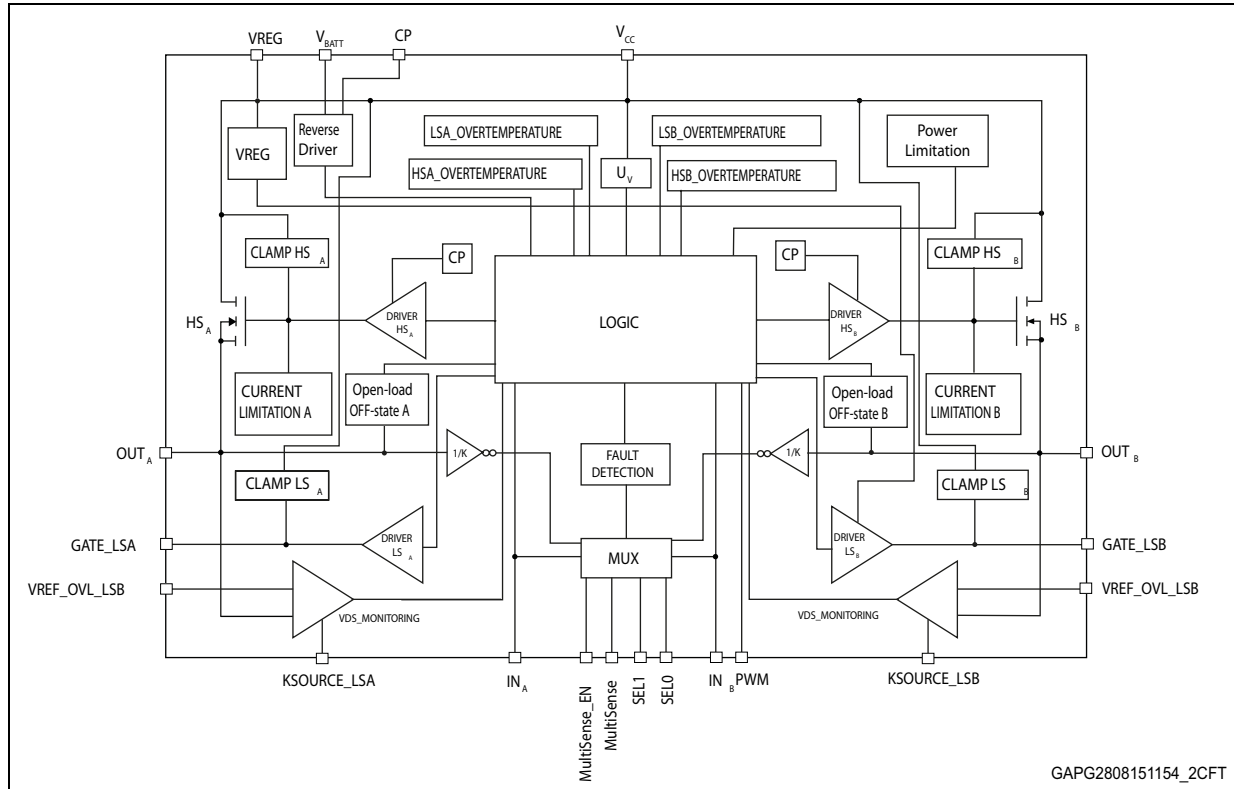

Table 1. Block description

Name	Description
Logic control	Allows the turn-on and the turn-off of the high-side and the low-side switches according to the truth table.
Undervoltage (U _S)	Shuts down the device for battery voltage below (4 V).
High-side and low-side clamp voltage	Protect the high-side and the low-side switches from the high voltage on the battery line.
High-side and low-side driver	Drive the gate of the concerned switch to allow a proper R _{On} for the leg of the bridge.
Current limitation	Limits the motor current in case of short circuit.
High-side overtemperature protection	In case of short-circuit with the increase of the junction temperature, it shuts down the concerned driver to prevent degradation and to protect the die.
VDS_MONITORING	Protection of LSD powers against short to battery failure
VREG	Internal voltage regulator that provides the supply for the gates of the external low-side switches
Fault detection	Signals an abnormal condition of the power stage (output shorted to ground or output shorted to battery) by a feedback on the MultiSense

Table 1. Block description (continued)

Name	Description
Power limitation	Limits the power dissipation of the high-side driver inside safe range in case of short to ground condition.
Open-load in OFF-state	Signalize, in combination with an external resistor, an open-load when the switches are off by a feedback on the MultiSense
T _{chip} monitoring	Provides a signal linked to the Chip temperature by a feedback on the MultiSense
V _{CC} monitoring	Provides a signal linked to the Chip temperature by a feedback on the MultiSense
Reverse driver	Drives an external PowerMOSFET to provide the reverse battery protection
CP	Charge pump to drive the external N-MOSFET used on the battery track for the reverse battery protection. The N-MOSFET source must be connected to the V _{batt} pin.

Figure 2. Configuration diagram (top view)

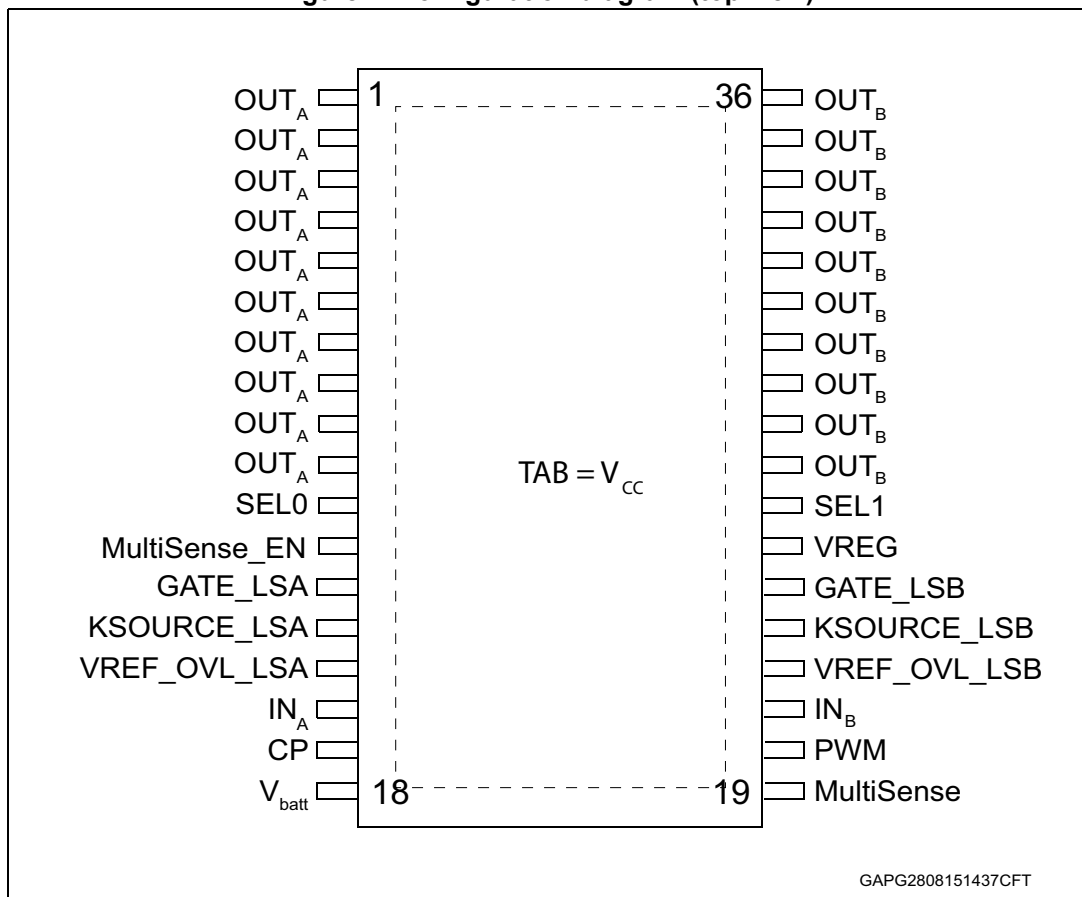

Table 2. Pin definitions and functions

Pin N°	Symbol	Function
20	PWM	PWM input.
25	VREG	Internal supply output
16	IN _A	Clockwise input.
18	V _{batt}	Battery supply, connection to the source of the external PowerMOS used for the reverse battery protection
19	MultiSense	Output of current sense and diagnostic feedback
12	MultiSense_EN	Enables the MultiSense diagnostic pin
11	SEL0	Address the MultiSense multiplexer (refer to Table 12)
26	SEL1	Address the MultiSense multiplexer (refer to Table 12)
21	IN _B	Counter clockwise input.
1, 2, 3, 4, 5, 6, 7, 8, 9, 10	OUT _A	Source of high-side switch A
27, 28, 29, 30, 31, 32, 33, 34, 35, 36	OUT _B	Source of high-side switch B
17	CP	Drives the gate of external P-MOSFET for the reverse battery protection
15	VREF_OVL_LSA	Sets the threshold for VDS_MONITORING feature for LSA
22	VREF_OVL_LSB	Sets the threshold for VDS_MONITORING feature for LSB
13	GATE_LSA	Gate driver of the external PowerMOS LSA
24	GATE_LSB	Gate driver of the external PowerMOS LSB
14	KSOURCE_LSA	Source of external LSA. Ground connection
23	KSOURCE_LSB	Source of external LSB. Ground connection
TAB	V _{CC}	Supply voltage. Drain of the high-side switches and connection to the drain of the external PowerMOS used for the reverse battery protection

Table 3. Suggested connection for unused and not connected pins

Connection / pin	OUTA, OUTB	Inx, PWM, SELx, Multisense_EN	Multisense	GATE_LSA, GATE_LSB, CP, VREG	VREF_OVL_LSA, VREF_OVL_LSB
Floating	X	X	X	X	X
To ground	Not allowed	Through 10 kΩ resistor		Not allowed	X

2 Electrical specifications

Figure 3. Current and voltage conventions

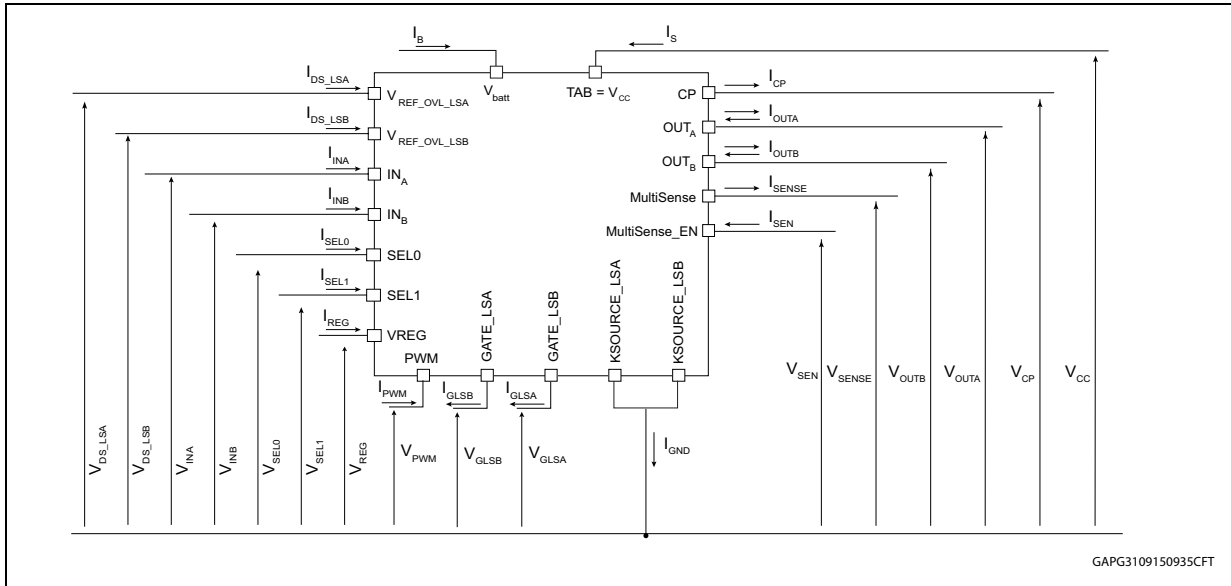

2.1 Absolute maximum ratings

Stressing the device above the rating listed in [Table 4](#) may cause permanent damage to the device. These are stress ratings only and operation of the device at these or any other conditions above those indicated in the Operating sections of this specification is not implied. Exposure to Absolute Maximum Rating conditions for extended periods may affect device reliability.

Table 4. Absolute maximum ratings

Symbol	Parameter	Value	Unit
V_{CC}	H-Bridge supply voltage	38	V
V_{BAT}	Maximum battery voltage ⁽¹⁾	-16 to 38	V
I_{max}	DC output current	Internally limited	A
I_R	Reverse output current (continuous) ⁽²⁾	30	A
I_{IN}	Input current (IN_A and IN_B pins)	-1 to 10	mA
I_{SEL}	$SEL_{0,1}$ DC input current	-1 to 10	mA
I_{PWM}	PWM Input current	-1 to 10	mA
$I_{MultiSense_EN}$	SenseEnable DC input current	-1 to 1.5	mA
$I_{MultiSense}$	MultiSense pin DC output current ($V_{GND} = V_{CC}$ and $V_{SENSE} < 0$ V)	10	mA
	MultiSense pin DC output current in reverse ($V_{CC} < 0$ V)	-20	mA
V_{REG}	V_{REG} DC voltage	12	V

Table 4. Absolute maximum ratings (continued)

Symbol	Parameter	Value	Unit
V _{CP}	V _{CP} DC voltage	V _{BATT} -6 to V _{BATT} +14	V
VGATE_LSx	GATE_LAS, GATE_LSB DC voltage	12	V
VREF_OVL_LSx	VREF_OVL_LSA, VREF_OVL_LSB input current	-1 to 10	V
V _{ESD}	Electrostatic discharge (Human body model: R = 1.5 kΩ; C = 100 pF) – MultiSenseVREG, VREF_OVL_LSx – IN _A , IN _B , OUT _A , OUT _B , PWM, SEL0, SEL1, SENSE_EN – GATE_LSx	2 4 4	kV
T _C	Junction operating temperature	-40 to 150	°C
T _{STG}	Storage temperature	-55 to 150	°C
I _{K_SOURCE_LSx}	DC reverse ground pin current (per leg)	100	mA

1. This applies with the n-channel MOSFET used for the reverse battery protection. Otherwise V_{BAT} has to be shorted to V_{CC}.
2. Based on the internal wires capability.

All logic pins cannot be left floating but they must be connected to GND if unused.

2.2 Thermal data

Table 5. Thermal data

Symbol	Parameter	Max. value	Unit
R _{thj-case}	Thermal resistance junction-case (per leg channel) (JEDEC JESD 51-8)	2.4	°C/W
R _{thj-amb}	Thermal resistance junction-ambient (JEDEC JESD 51-5) ⁽¹⁾	50.6	°C/W
R _{thj-amb}	Thermal resistance junction-ambient (JEDEC JESD 51-7)	16.6	°C/W

1. Device mounted on two-layers 2s0p PCB with 2 cm².heatsink copper trace.

2.3 Electrical characteristics

$V_{CC} = 7\text{ V}$ up to 28 V ; $-40\text{ °C} < T_j < 150\text{ °C}$, unless otherwise specified.

Table 6. Power section

Symbol	Parameter	Test conditions	Min.	Typ.	Max.	Unit
V_{CC}	Operating supply voltage		4		28	V
I_S	Supply current	Off-state standby $I_{N_A} = I_{N_B} = PWM = \text{Multisense_EN} = 0$; $SEL_{0,1} = 0$; $T_j = 25\text{ °C}$; $V_{CC} = 13\text{ V}$			1	μA
		Off-state standby; $I_{N_A} = I_{N_B} = PWM = \text{Multisense_EN} = 0$; $SEL_{0,1} = 0$; $V_{CC} = 13\text{ V}$; $T_j = 85\text{ °C}$			1	μA
		Off-state standby; $I_{N_A} = I_{N_B} = PWM = \text{Multisense_EN} = 0$; $SEL_{0,1} = 0$; $V_{CC} = 13\text{ V}$; $T_j = 125\text{ °C}$			10	μA
		Off-state (no standby) $I_{N_A} = I_{N_B} = PWM = \text{Multisense_EN} = 0$; $SEL_{0,1} = 5\text{ V}$		4	8	mA
		On-state: I_{N_A} or $I_{N_B} = 5\text{ V}$; $PWM = 0\text{ V}$ or $PWM = 5\text{ V}$; $SEL_0 = 0$ or $SEL_0 = 5\text{ V}$; $SEL_1 = 0$ or $SEL_1 = 5\text{ V}$		6	12	mA
		On-state: $I_{N_A} = I_{N_B} = 5\text{ V}$; $PWM = 0\text{ V}$ or $PWM = 5\text{ V}$; $SEL_0 = 0$ or $SEL_0 = 5\text{ V}$; $SEL_1 = 0$ or $SEL_1 = 5\text{ V}$		9	18	mA
t_{D_STBY}	Standby mode blanking time	$V_{CC} = 13\text{ V}$; $I_{N_A} = I_{N_B} = SEL_1 = \text{MultiSense_EN} = PWM = 0\text{ V}$; V_{SEL0} from 5 V to 0 V .	60	300	550	μs
R_{ONHS}	Static high-side resistance	$I_{OUT} = 12\text{ A}$; $T_j = 25\text{ °C}$, $V_{CC} = 13\text{ V}$		8		m Ω
		$I_{OUT} = 12\text{ A}$; $T_j = -40\text{ °C}$ to 150 °C			16	m Ω
		$V_{CC} = 4\text{ V}$, $I_{OUT} = 12\text{ A}$, $T_j = 25\text{ °C}$		8		
V_f	High-side free-wheeling diode forward voltage	$I_{OUT} = -12\text{ A}$; $T_j = 150\text{ °C}$		0.6	0.7	V
$I_{L(off)}$	Off-State Output current of one output	$I_{N_A} = I_{N_B} = PWM = 0$; $V_{OUT} = 0\text{ V}$; $V_{CC} = 13\text{ V}$; $T_j = 25\text{ °C}$	0		0.5	μA
		$I_{N_A} = I_{N_B} = PWM = 0$; $V_{OUT} = 0\text{ V}$; $V_{CC} = 13\text{ V}$; $T_j = 125\text{ °C}$	0		5	μA
$I_{L(off_h)}$	Off-state output current of one output with other HSD on	$I_{N_A} = PWM = 0$; $I_{N_B} = 5\text{ V}$; $V_{CC} = 13\text{ V}$	20		60	μA

Table 7. Logic inputs (IN_A, IN_B) (V_{CC} = 7 V up to 28 V; -40 °C < T_j < 150 °C)

Symbol	Parameter	Test conditions	Min.	Typ.	Max.	Unit
V _{IL}	Input low level voltage				0.9	V
V _{IH}	Input high level voltage		2.1			V
V _{IHYST}	Input hysteresis voltage		0.2			V
V _{ICL}	Input clamp voltage	I _{IN} = 1 mA	5.3		7.2	V
		I _{IN} = -1 mA		-0.7		V
I _{INL}	Input current	V _{IN} = 0.9 V	1			µA
I _{INH}	Input current	V _{IN} = 2.1 V			10	µA
SEL₀, SEL₁ (V_{CC} = 7 V up to 18 V; -40 °C < T_j < 150 °C)						
V _{SELL}	Input low level voltage				0.9	V
I _{SELL}	Low level input current	V _{SEL} = 0.9 V	1			µA
V _{SELH}	Input high level voltage		2.1			V
I _{SELH}	High level input current	V _{SEL} = 2.1 V			10	µA
V _{SEL(hyst)}	Input hysteresis voltage		0.2			V
V _{SELCL}	Input clamp voltage	I _{SEL} = 1 mA	5.3		7.2	V
		I _{SEL} = -1 mA		-0.7		V
PWM (V_{CC} = 7 V up to 28 V; -40 °C < T_j < 150 °C)						
V _{PWM}	Input low level voltage				0.9	V
I _{PWM}	Low level input current	V _{PWM} = 0.9 V	1			µA
V _{PWM}	Input high level voltage		2.1			V
I _{PWMH}	High level input current	V _{PWM} = 2.1 V			10	µA
V _{PWM(hyst)}	Input hysteresis voltage		0.2			V
V _{PMWCL}	Input clamp voltage	I _{PWM} = 1 mA	5.3		7.2	V
		I _{PWM} = -1 mA		-0.7		V
MultiSense_EN (V_{CC} = 7 V up to 18 V; -40 °C < T_j < 150 °C)						
V _{SEnL}	Input low level voltage				0.9	V
I _{SEnL}	Low level input current	V _{SEn} = 0.9 V	1			µA
V _{SEnH}	Input high level voltage		2.1			V
I _{SEnH}	High level input current	V _{SEn} = 2.1 V			10	µA
V _{SEn(hyst)}	Input hysteresis voltage		0.2			V
V _{SEnCL}	Input clump voltage	I _{SEn} = 1 mA	5.3		7.5	V
		I _{SEn} = -1 mA		-0.7		V

Table 8. HSD switching ($V_{CC} = 13\text{ V}$; $R_{LOAD} = 1.1\ \Omega$)

Symbol	Parameter	Test conditions	Min.	Typ.	Max.	Unit
$t_{d(on)}$	Turn-on delay time	Input rise time $< 1\ \mu\text{s}$; MultiSense_EN = 5 V (no standby); SEL _{0,1} = 0; PWM = 0 (see Figure 6)		53		μs
$t_{d(off)}$	Turn-off delay time	Input rise time $< 1\ \mu\text{s}$; MultiSense_EN = 5 V (no standby); SEL _{0,1} = 0; PWM = 0 (see Figure 6)		20		μs

Table 9. Gate driver for external MOS parameters ($V_{CC} = 13\text{ V}$)

Symbol	Parameter	Test conditions	Min.	Typ.	Max.	Unit
$f^{(1)}$	PWM frequency		0		20	kHz
V_{gs_lzd}	Gate_LSD voltage	PWM = 5 V; IN _x = 0 V			10	V
		$V_{CC} = 4\text{ V}$, PWM = 5 V, IN _x = 0 V, T _j = 25 °C		4		V
t_{cross}	Low-side turn-on delay time	Input rise time $< 1\ \mu\text{s}$ (see Figure 7)	40	160	300	μs
t_{gr_ls}	Rise time	$V_{CC} = 13.5\text{ V}$; R _g = 0 Ω ; C _g = 4.7 nF (see Figure 5)		0.25	0.5	μs
t_{gf_ls}	Fall time	$V_{CC} = 13.5\text{ V}$; R _g = 0 Ω ; C _g = 4.7 nF (see Figure 5)		0.35	0.5	μs

1. Parameter guaranteed by design.

Table 10. Protections and diagnostics ($7\text{ V} < V_{CC} < 18\text{ V}$; $-40\text{ }^\circ\text{C} < T_j < 150\text{ }^\circ\text{C}$)

Symbol	Parameter	Test conditions	Min.	Typ.	Max.	Unit
V_{USD}	Undervoltage shutdown	V_{CC} falling			4	V
$V_{USDreset}$	Undervoltage shutdown reset	V_{CC} rising			5	V
$V_{USDhyst}$	Undervoltage shutdown hysteresis			0.3		V
I_{LIM_HSD}	High-side current limitation		51	77	110	A
		$V_{CC} = 4\text{ V}$, T _j = 25 °C ⁽¹⁾		66		A
V_{CL_HSD}	High-side driver clamp voltage (V_{CC} to OUT _A = 0 or OUT _B = 0)	I _{OUT} = 100 mA; t _{clamp} = 1 ms; I _{clamp} = 100 mA	38	46		V
$V_{CL_LSD}^{(1)}$	Low-side clamp voltage (OUT _A = V_{CC} or OUT _B = V_{CC} to GND)	I _{OUT} = 100 mA; t _{clamp} = 1 ms; I _{clamp} = 100 mA	38	46	52	V
$t_{DEL_OVL_LSD}$	Low-side drain-current overload blanking time		1		5	μs

Table 10. Protections and diagnostics (7 V < V_{CC} < 18 V; -40 °C < T_j < 150 °C) (continued)

Symbol	Parameter	Test conditions	Min.	Typ.	Max.	Unit
I _{REF_OVL_LSD}	Low-side drain-current overload reference current		40	50	60	μA
V _{REF_OVL_LSD_MIN}	Low-side drain-current overload threshold voltage minimum		0.32	0.4	0.8	V
V _{REF_OVL_LSD_MAX}	Low-side drain-current overload threshold voltage maximum		1.6	2	2.4	V
T _{TSD_HSD}	High-side thermal shutdown temperature	IN _x = 2.1 V	150	175	200	°C
T _{TR_HSD}	High-side thermal reset temperature		135			°C
T _{HYST_HSD}	High-side thermal hysteresis (T _{SD_HSD} - T _{R_HSD})			7		°C
ΔT _{j_SD} ⁽¹⁾	Dynamic temperature			60		°C
I _{L(off3)}	OFF-state output sink current with V _{OUT} = V _{CC}	IN _A = IN _B = 0; PWM = 0; V _{OUT} = V _{CC}	0	1.1	2.5	mA
V _{CL}	Clamp signal (V _{CC} to GND)	I _{OUT} = 100 mA; t _{clamp} = 1 ms; I _{clamp} = 100 mA	38	46	52	V
V _{OL}	OFF-state open-load voltage detection threshold	IN _A = IN _B = 0; PWM = 0; V _{SELO} = 5 V for CHA; V _{SELO} = 0 V and within t _{D_STBY} for CHB	2	3	4	V
I _{L(off2)}	OFF-state output sink current	IN _A = IN _B = 0; V _{OUT} = 2 V; PWM = 2 V; V _{SELO} = 5 V for CHA; V _{SELO} = 0 V and within t _{D_STBY} for CHB	-150		-5	μA
t _{DSTKON}	OFF-state diagnostic delay time from falling edge of INPUT (see Figure 4)	IN _A = 5 V to 0 V; IN _B = 0; PWM = 0; V _{SELO} = 5 V; I _{OUT} = 0 A; V _{OUTA} = 4 V	40	160	300	μs
V _{GS_CP}	CP output voltage	V _{CP} - V _{BAT} = V _{GS_CP}	8	12	15	V
		V _{BAT} = -16 V; V _{CP} - V _{BAT} = V _{GS_CP}		0.6		V
t _{D_VOL}	OFF-state diagnostic delay time from rising edge of V _{OUT} (see Figure 10)	IN _A = IN _B = 0 V; PWM = 0; V _{OUTx} = 0 V to 4 V; V _{SEL1} = 0 V for CHA; V _{SEL0,1} = 0 V; SENSE_EN = 5 V for CHB		5	30	μs
t _{LATCH_RST_HS}	Input reset time for high-side fault unlatch	V _{INx} = 5 V to 0 V; HSDx faulting (see Figure 8)	3	10	20	μs

Table 10. Protections and diagnostics (7 V < V_{CC} < 18 V; -40 °C < T_j < 150 °C) (continued)

Symbol	Parameter	Test conditions	Min.	Typ.	Max.	Unit
t _{LATCH_RST_LS}	Input reset time for low-side fault unlatch	V _{INx} = 0 V to 5 V; LSDx faulting (see Figure 9)	3	10	20	μs
t _{stby_ovl_1sd}	Low-side drain current overload delay time form stby exit	50% of V _{SENSEH}		20		μs

1. Parameter guaranteed by design and characterization; not subject to production test.

Table 11. MultiSense (7 V < V_{CC} < 18 V; -40 °C < T_j < 150 °C)

Symbol	Parameter	Test conditions	Min.	Typ.	Max.	Unit
V _{SENSE_CL}	MultiSense clamp voltage	V _{SEn} = 0 V; I _{SENSE} = -1 mA		7		V
		V _{SEn} = 0 V; I _{SENSE} = 1 mA	-17		-12	V
K _{OL}	I _{OUT} /I _{SENSE}	I _{OUT} = 0.25 A; V _{SENSE} = 0.5 V; T _j = -40 °C to 150 °C	6300	10500	14700	
K ₀	I _{OUT} /I _{SENSE}	I _{OUT} = 2 A; V _{SENSE} = 0.5 V; T _j = -40 °C to 150 °C	8400	10900	13400	
K ₁	I _{OUT} /I _{SENSE}	I _{OUT} = 6 A; V _{SENSE} = 0.5 V; T _j = -40 °C to 150 °C	8700	11000	13200	
K ₂	I _{OUT} /I _{SENSE}	I _{OUT} = 12 A; V _{SENSE} = 4 V; T _j = -40 °C to 150 °C	9000	11000	13000	
K ₃	I _{OUT} /I _{SENSE}	I _{OUT} = 24 A; V _{SENSE} = 4 V; T _j = -40 °C to 150 °C	9200	11000	12200	
dK _{OL} /K _{OL} ⁽¹⁾	Analog sense current drift	I _{OUT} = 0.25 A; V _{SENSE} = 0.5 V; T _j = -40 °C to 150 °C	-25		25	%
dK ₀ /K ₀ ⁽¹⁾	Analog sense current drift	I _{OUT} = 2 A; V _{SENSE} = 0.5 V; V _{SENSE_EN} = 0 V; T _j = -40 °C to 150 °C	-5		5	%
dK ₁ /K ₁ ⁽¹⁾	Analog sense current drift	I _{OUT} = 6 A; V _{SENSE} = 0.5 V; V _{SENSE_EN} = 0 V; T _j = -40 °C to 150 °C	-5		5	%
dK ₂ /K ₂ ⁽¹⁾	Analog sense current drift	I _{OUT} = 12 A; V _{SENSE} = 4 V; T _j = -40 °C to 150 °C	-5		5	%
dK ₃ /K ₃ ⁽¹⁾	Analog sense current drift	I _{OUT} = 24 A; V _{SENSE} = 4 V; T _j = -40 °C to 150 °C	-5		5	%
V _{SENSE_SAT}	Max analog sense output voltage	V _{CC} = 7 V; R _{SENSE} = 10 kΩ; I _{OUT} = 24 A; V _{SEL0} = 5 V; T _j = 150 °C	5			V
I _{SENSE_SAT} ⁽²⁾	MultiSense saturation current	V _{CC} = 7 V; V _{INA} = 5 V; V _{INB} = 0 V; V _{SEL0} = 5 V; T _j = 150 °C	4			mA
I _{OUT_SAT} ⁽²⁾	Output saturation current	V _{CC} = 7 V; V _{SENSE} = 4 V; V _{INA} = 5 V; V _{INB} = 0 V; V _{SEL0} = 5 V; T _j = 150 °C	48			A

Table 11. MultiSense (7 V < V_{CC} < 18 V; -40 °C < T_j < 150 °C) (continued)

Symbol	Parameter	Test conditions	Min.	Typ.	Max.	Unit
V _{OUT_MSD} ⁽²⁾	Output Voltage for MultiSense shutdown	V _{INA} = 5 V; V _{INB} = 0 V; V _{SEL0} = 5 V; V _{SEL1} = 0 V; R _{SENSE} = 2.7 kΩ; I _{OUT} = 24 A		5		V
I _{SENSE0}	MultiSense leakage current	V _{MultiSense} = V _{SENSE_EN} = PWM = 0 V; I _{NA} = I _{NB} = 0 V; SEL ₀ = SEL ₁ = 0; T _j = -40 °C to 150 °C (standby)	0		0.5	μA
		SEn = 5 V; I _{NA} = I _{NB} = 5 V; PWM = 0 V; SideX diagnostic selected; I _{OUTx} = 0 A E.g. – SideA: SEL0 = 5 V; SEL1 = 0 V; I _{OUTA} = 0 A; I _{OUTB} = 12 A – SideB: SEL0 = 0 V; SEL1 = 0 V; I _{OUTA} = 12 A; I _{OUTB} = 0 V	0		12	μA
		SEn = 5 V; PWM = 0 V; SideX diagnostic selected; HSx OFF E.g. – SideA: SEL0 = 5 V; SEL1 = 0 V; I _{NA} = 0 V; I _{NB} = 5 V; I _{OUTB} = 12 A – SideB: SEL0 = 0 V; SEL1 = 0 V; I _{NA} = 5 V; I _{NB} = 0 V; I _{OUTA} = 12 A	0		10	μA
V _{SENSEH}	MultiSense output voltage in fault condition	V _{CC} = 13 V; R _{SENSE} = 1 kΩ; – E.g: Ch ₀ in open-load; V _{IN} = 0 V; I _{OUT} = 0 A; V _{OUT} = 4 V	5		7	V
I _{SENSEH}	MultiSense current in fault condition	9 V < V _{CC} < 18 V; V _{SENSE} = 5 V; MultiSense in fault condition	10	20	30	mA
Chip temperature analog feedback						
V _{SENSE_TC}	MultiSense output voltage proportional to chip temperature	V _{SENSE_EN} = 5 V; V _{SEL0} = 0 V; V _{SEL1} = 5 V; V _{IN} = 0 V; R _{SENSE} = 1 kΩ; T _j = -40 °C	2.325	2.41	2.495	V
		V _{SENSE_EN} = 5 V; V _{SEL0} = 0 V; V _{SEL1} = 5 V; V _{IN} = 0 V; R _{SENSE} = 1 kΩ; T _j = 25 °C	1.985	2.07	2.155	V
		V _{SENSE_EN} = 5 V; V _{SEL0} = 0 V; V _{SEL1} = 5 V; V _{IN} = 5 V; R _{SENSE} = 1 kΩ; T _j = 125 °C	1.435	1.52	1.605	V
dV _{SENSE_TC} /dT ⁽²⁾	Temperature coefficient	T _j = -40 °C to 150 °C		-5.5		mV/K
Transfer function		V _{SENSE_TC} (T) = V _{SENSE_TC} (T ₀) + dV _{SENSE_TC} /dT * (T - T ₀)				
V_{CC} supply voltage analog feedback						

Table 11. MultiSense (7 V < V_{CC} < 18 V; -40 °C < T_j < 150 °C) (continued)

Symbol	Parameter	Test conditions	Min.	Typ.	Max.	Unit
V _{SENSE_VCC}	MultiSense output voltage proportional to V _{CC} supply voltage	V _{CC} = 13 V; V _{SENSE_EN} = 5 V; V _{SEL0} = V _{SEL1} = 5 V; R _{SENSE} = 1 kΩ	3.16	3.23	3.3	V
Transfer function		V _{SENSE_VCC} = V _{CC} /4				
MultiSense timings (Multiplexer transition times)⁽²⁾						
t _{D_CStoTC}	MultiSense transition delay from current sense to T _C sense	V _{INA} = 5 V; V _{SENSE_EN} = 5 V; V _{SEL0} = 5 V to 0 V; V _{SEL1} = 0 V to 5 V; I _{OUTA} = 2.5 A; R _{SENSE} = 1 kΩ; V _{SENSE_TC} = 90% of V _{SENSE_TC_FINAL}			60	μs
t _{D_TcToCS}	MultiSense transition delay from T _C sense to current sense	V _{INA} = 5 V; V _{SENSE_EN} = 5 V; V _{SEL0} = 0 V to 5 V; V _{SEL1} = 5 V to 0 V; I _{OUTA} = 2.5 A; R _{SENSE} = 1 kΩ; I _{SENSE} = 90% of I _{SENSE_MAX}			20	μs
t _{D_CStoVCC}	MultiSense transition delay from current sense to V _{CC} sense	V _{INA} = 5 V; V _{SENSE_EN} = 5 V; V _{SEL0} = 5 V; V _{SEL1} = 0 V to 5 V; I _{OUTA} = 2.5 A; R _{SENSE} = 1 kΩ; V _{SENSE_VCC} = 90% of V _{SENSE_VCC_FINAL}			60	μs
t _{D_VCCtoCS}	MultiSense transition delay from V _{CC} sense to current sense	V _{INA} = 5 V; V _{SENSE_EN} = 5 V; V _{SEL0} = 5 V; V _{SEL1} = 5 V to 0 V; I _{OUTA} = 2.5 A; R _{SENSE} = 1 kΩ; I _{SENSE} = 90% of I _{SENSE_MAX}			20	μs
t _{D_TcToVCC}	MultiSense transition delay from T _C sense to V _{CC} sense	V _{CC} = 13 V; T _j = 125 °C; V _{SENSE_EN} = 5 V; V _{SEL0} = 0 V to 5 V; V _{SEL1} = 5 V; R _{SENSE} = 1 kΩ; V _{SENSE_VCC} = 90% of V _{SENSE_VCC_FINAL}			20	μs
t _{D_VCCtoTC}	MultiSense transition delay from V _{CC} sense to T _C sense	V _{CC} = 13 V; T _j = 125 °C; V _{SENSE_EN} = 5 V; V _{SEL0} = 5 V to 0 V; V _{SEL1} = 5 V; R _{SENSE} = 1 kΩ; V _{SENSE_TC} = 90% of V _{SENSE_TC_FINAL}			20	μs
MultiSense timings (CurrentSense mode)						
t _{DSENSE1H}	Current sense settling time from rising edge of V _{SENSE_EN}	V _{INA} = 5 V; V _{INB} = 0 V; V _{SENSE_EN} = 0 V to 5 V; R _{SENSE} = 1 kΩ; R _L = 2.6 Ω; V _{PWM} = 5 V; V _{SEL0} = 5 V; V _{SEL1} = 0 V			60	μs

Table 11. MultiSense (7 V < V_{CC} < 18 V; -40 °C < T_j < 150 °C) (continued)

Symbol	Parameter	Test conditions	Min.	Typ.	Max.	Unit
t _{DSENSE1L}	Current sense disable delay time from falling edge of V _{SENSE_EN}	V _{INA} = 5 V; V _{INB} = 0 V; V _{SENSE_EN} = 5 V to 0 V; R _{SENSE} = 1 kΩ; R _L = 2.6 Ω; V _{PWM} = 5 V; V _{SEL0} = 5 V; V _{SEL1} = 0 V			20	μs
t _{DSENSE2H}	V _{SENSE_TC} settling time from rising edge of V _{SENSE_EN}	V _{SENSE_EN} = 0 V to 5 V; V _{SEL0} = 0 V; V _{SEL1} = 5 V; R _{SENSE} = 1 kΩ			60	μs
t _{DSENSE2L}	V _{SENSE_TC} settling time from rising edge of V _{SENSE_EN}	V _{SENSE_EN} = 5 V to 0 V; V _{SEL0} = 0 V; V _{SEL1} = 5 V; R _{SENSE} = 1 kΩ			20	μs
MultiSense timings (V_{CC} voltage sensor mode)						
t _{DSENSE3H}	V _{SENSE_VCC} settling time from rising edge of V _{SENSE_EN}	V _{SENSE_EN} = 0 V to 5 V; V _{SEL0} = 5 V; V _{SEL1} = 5 V; R _{SENSE} = 1 kΩ			60	μs
t _{DSENSE3L}	V _{SENSE_VCC} settling time from rising edge of V _{SENSE_EN}	V _{SENSE_EN} = 5 V to 0 V; V _{SEL0} = 5 V; V _{SEL1} = 5 V; R _{SENSE} = 1 kΩ			20	μs

1. Analog sense current drift is deviation of factor K for a given device over (-40°C to 150°C and 9 V < V_{CC} < 18 V) with respect to its value measured at T_j = 25 °C, V_{CC} = 13 V.
2. Parameter guaranteed by design and characterization; not subject to production test.

Figure 4. T_{DSTKON}

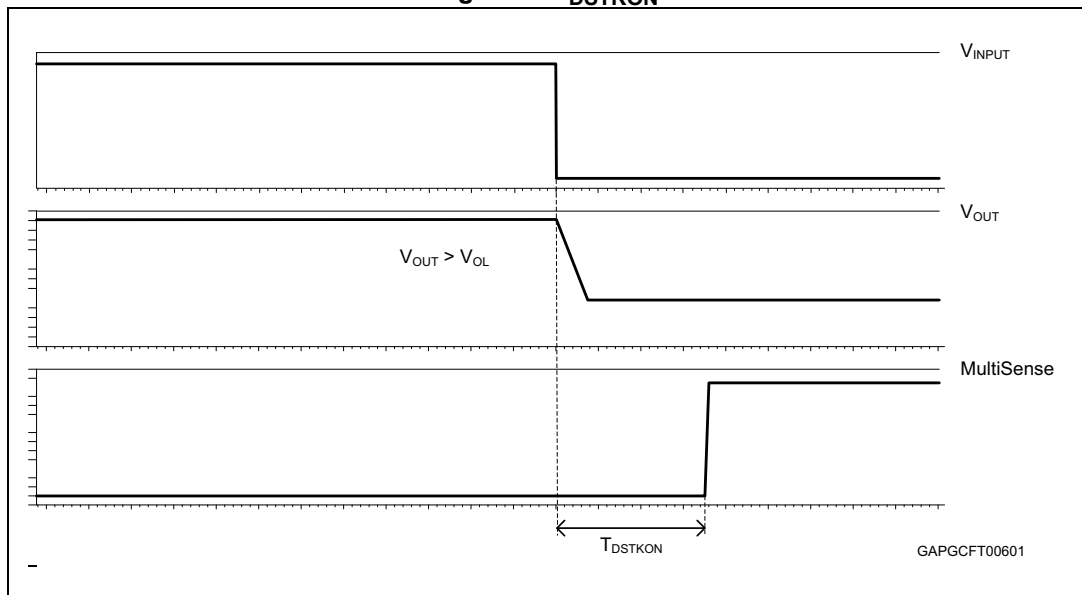

Figure 5. Definition of the low-side switching times

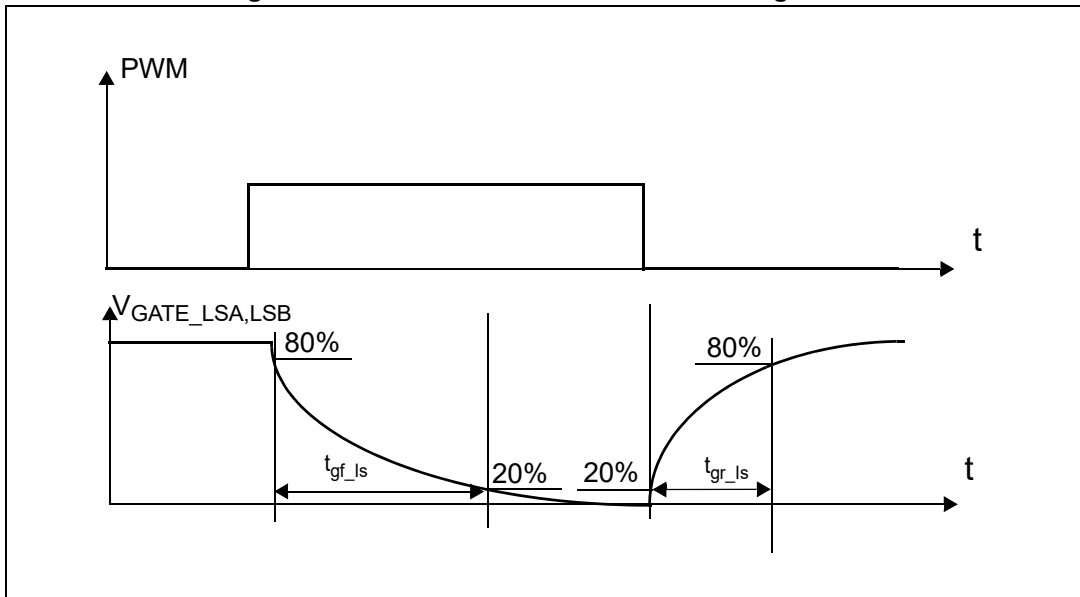

Figure 6. Definition of the high-side switching times

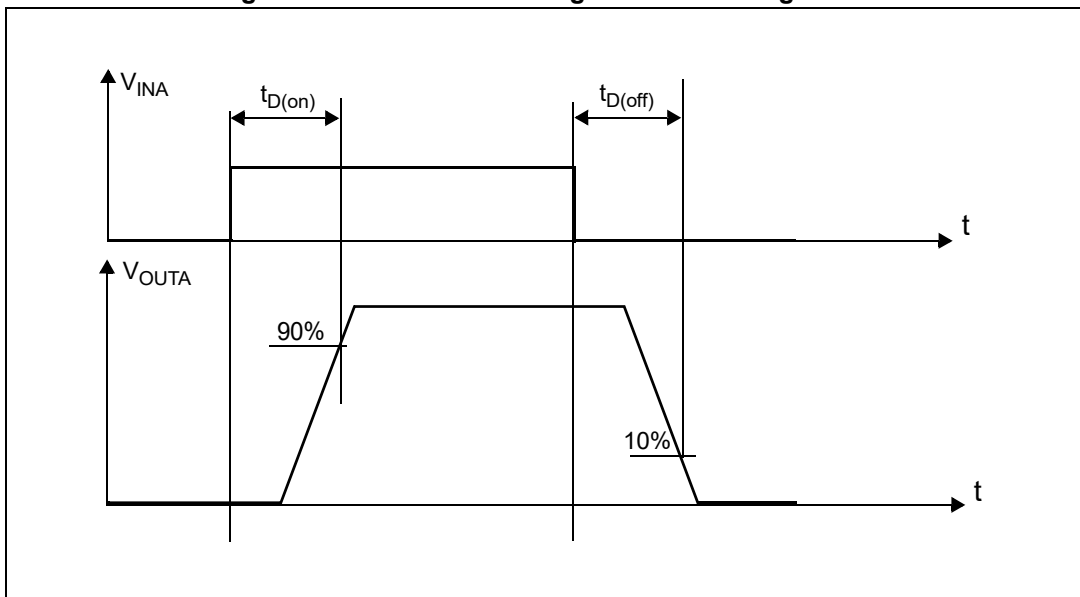

Figure 7. Low-side turn-on delay time

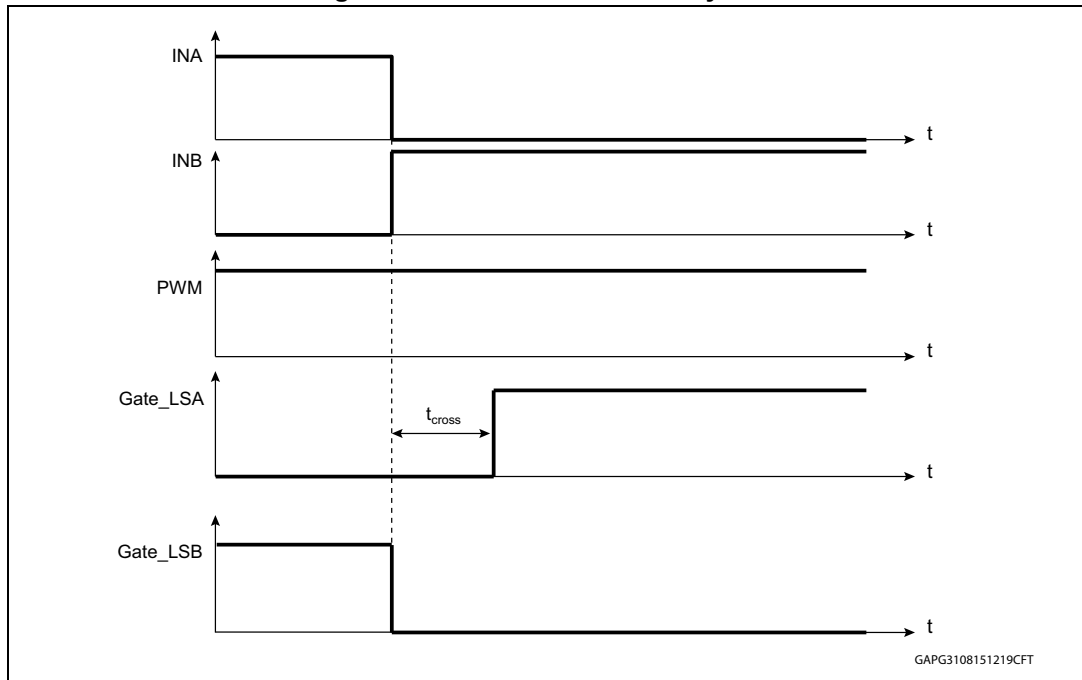
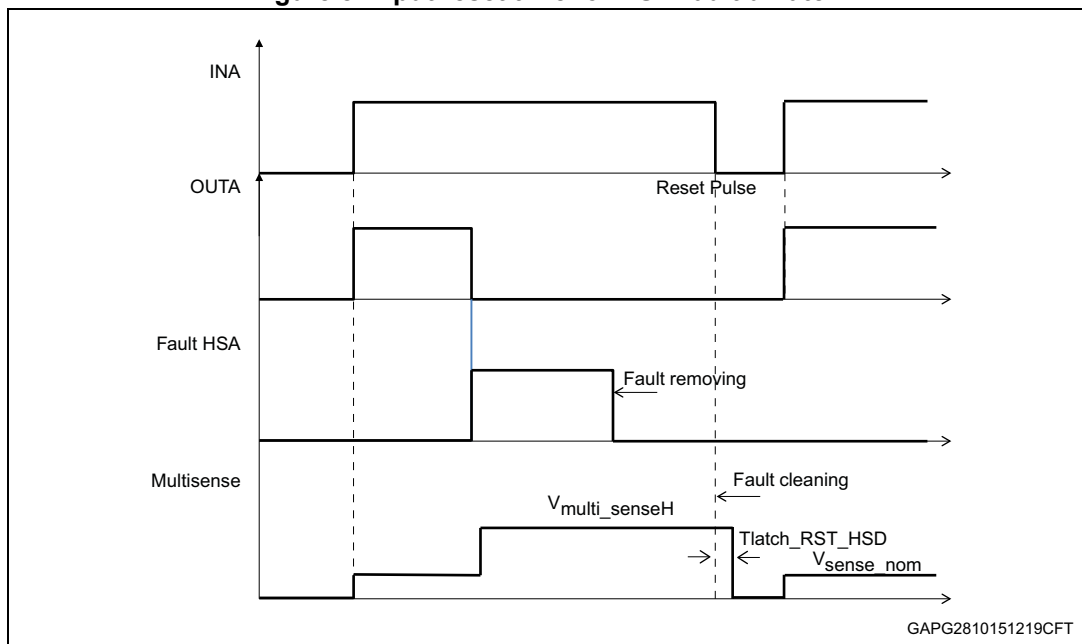
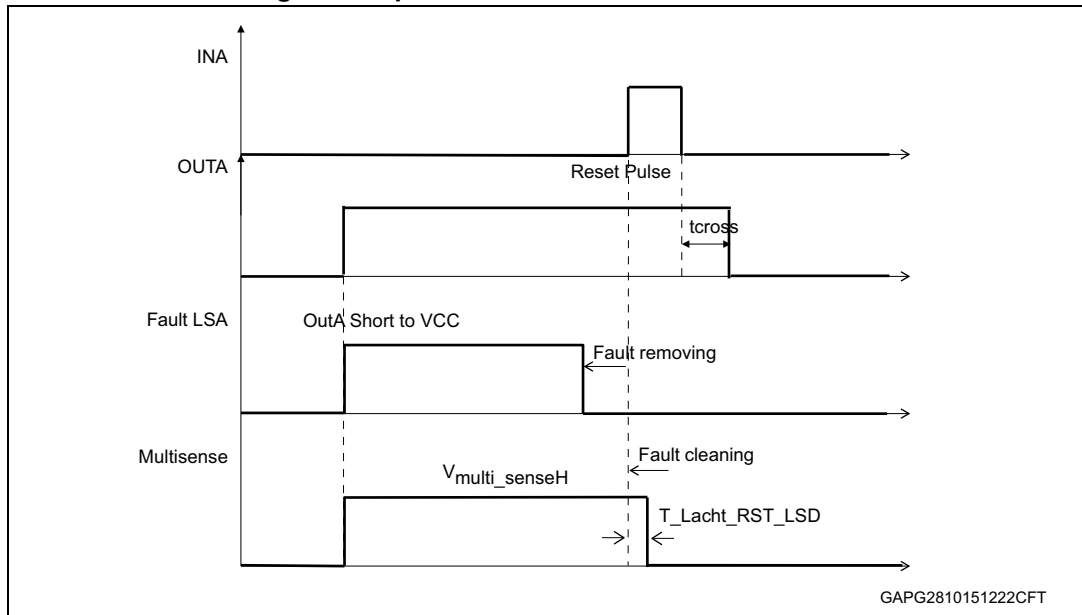

Figure 8. Input reset time for HSD-fault unlatch



Note: *Multisense_EN=1*

Figure 9. Input reset time for LSD-fault unlatch



Note: *Multisense_EN=1*

Figure 10. OFF-state diagnostic delay time from rising edge of VOUT (t_{D_VOL})

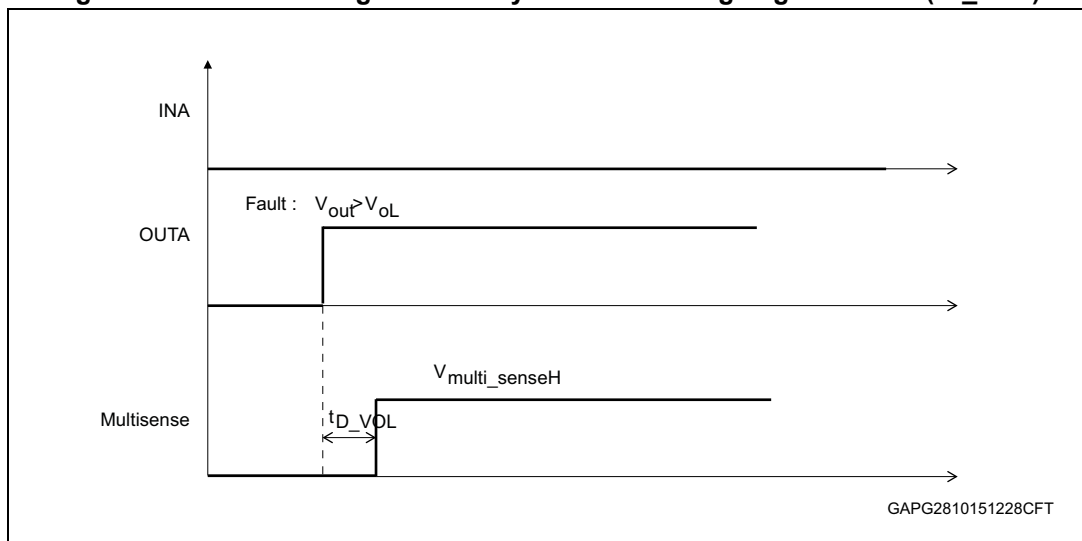

Note: *Multisense_EN=1*

Table 12. Operative condition - truth table

INA	INB	PWM	SEL0	SEL1	MultiSense_EN	MultiSense	HSA	LSA	HSB	LSB
0	0	1	0	0	1	High-Z	OFF	ON	OFF	ON
		1	1	0	1	High-Z	OFF	ON	OFF	ON
0	1	0	0	0	1	Current Monitoring HSB	OFF	OFF	ON	OFF
		1	0	0	1	Current Monitoring HSB	OFF	ON	ON	OFF
0	1	0	1	0	1	High-Z	OFF	OFF	ON	OFF
		1	1	0	1	High-Z	OFF	ON	ON	OFF
1	0	0	0	0	1	High-Z	ON	OFF	OFF	OFF
		1	0	0	1	High-Z	ON	OFF	OFF	ON
1	0	0	1	0	1	Current Monitoring HSA	ON	OFF	OFF	OFF
		1	1	0	1	Current Monitoring HSA	ON	OFF	OFF	ON
1	1	X ⁽¹⁾	0	0	1	Current Monitoring HSB	ON	OFF	ON	OFF
			1	0	1	Current Monitoring HSA	ON	OFF	ON	OFF
0	0	0	1	0	1	Off-state diagnostic OUTA	OFF	OFF	OFF	OFF
0	0	0	0	0	1	Off-state diagnostic OUTB	OFF	OFF	OFF	OFF
X	X	X	0	1	1	T _{CHIP} Monitoring	—	—	—	—
X	X	X	1	1	1	V _{CC} Monitoring	—	—	—	—
X	X	X	X	X	0	High-Z ⁽²⁾	—	—	—	—

1. X: the level of the pin can be 0 or 1.
2. When IN_A = IN_B = PWM = SEL0 = SEL1 = MultiSense_EN = 0 device enters standby after T_{DSTBY}.

Table 13. On-state fault conditions- truth table

Digital input pins ⁽¹⁾				MultiSense	Comment
INA	INB	PWM	SEL0		
0	0	1	0	V _{SENSE_H}	VDS LSB protection triggered; LSB latched off
0	0	1	1	V _{SENSE_H}	VDS LSA protection triggered; LSA latched off
0	1	X	0	V _{SENSE_H}	HSB protection triggered; HSB latched off
0	1	1	1	V _{SENSE_H}	VDS LSA protection triggered; LSA latched off
1	0	1	0	V _{SENSE_H}	VDS LSB protection triggered; LSB latched off
1	0	X	1	V _{SENSE_H}	HSA protection triggered; HSA latched off
1	1	X	0	V _{SENSE_H}	HSB protection triggered; HSB latched off
1	1	X	1	V _{SENSE_H}	HSA protection triggered; HSA latched off

1. MultiSense_EN = 1 and SEL1 = 0 are mandatory for fault detection. Other logic combinations on digital input pins not reported on the above table do not allow to detect a latched-off channel.

Table 14. Off-state — truth table

INA	INB	SEL0	SEL1	PWM	OUTA	OUTB	MultiSense_EN	MultiSense	Description
Off-state diagnostic									
0	0	1	0	0	$V_{OUTA} > V_{OL}$	X	1	V_{SENSEH}	Case 1: OUT_A shorted to V_{CC} if no pull-up is applied. Case 2: NO open-load in full bridge configuration with an external pull-up on OUT_B Case 3: open-load in half bridge configuration with an external pull-up on OUT_A (motor connected between Out and Ground)
					$V_{OUTA} < V_{OL}$	X	1	Hi-Z	Case 1: open-load in full Bridge configuration with an external pull-up on OUT_B Case 2: NO open-load in half Bridge configuration with external pull-up on OUT_A (motor connected between Out and Ground)
		0	0		X	$V_{OUTB} > V_{OL}$	1	V_{SENSEH}	Case 1: OUT_B shorted to V_{CC} if no pull-up is applied Case 2: NO open-load in full bridge configuration with external pull-up on OUT_A Case 3: open-load in half bridge configuration with external pull-up on OUT_B (motor connected between Out and Ground)
					X	$V_{OUTB} < V_{OL}$	1	Hi-Z	Case1: open-load in full Bridge configuration with an external pull-up on OUT_A Case 2. NO open-load in half Bridge configuration with external pull-up on OUT_B (motor connected between Out and Ground)

Note: To power on the device from standby, it is recommended to: toggle INA or INB or SEL0 or SEL1 from 0 to 1 first to come out from STBY mode; toggle PWM from 0 to 1 with a delay of 20 microsecond this avoids any overstress on the device in case of existing short-to-battery.

2.4 Waveforms

Figure 11. Normal operative conditions (resistive load)

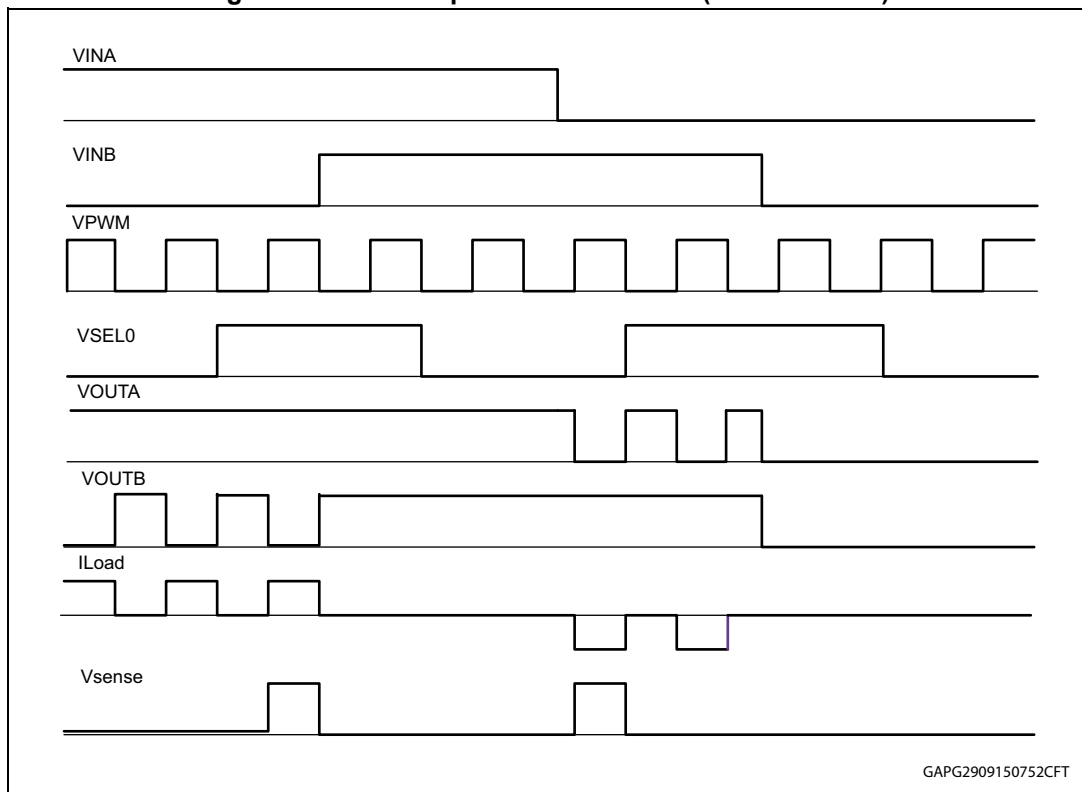

Note: *MultiSense_EN=1*

Figure 12. Out shorted to ground and short clearing

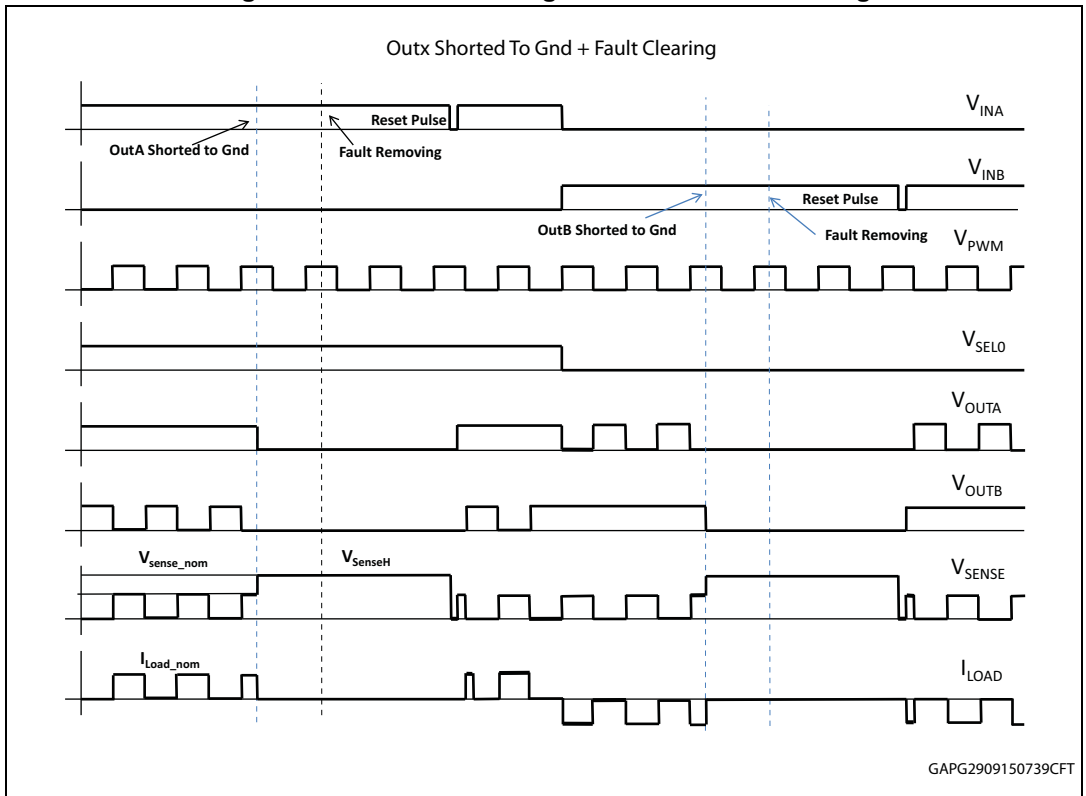

Note: *MultiSense_EN=1*

Figure 13. OUT shorted to Vcc and short clearing

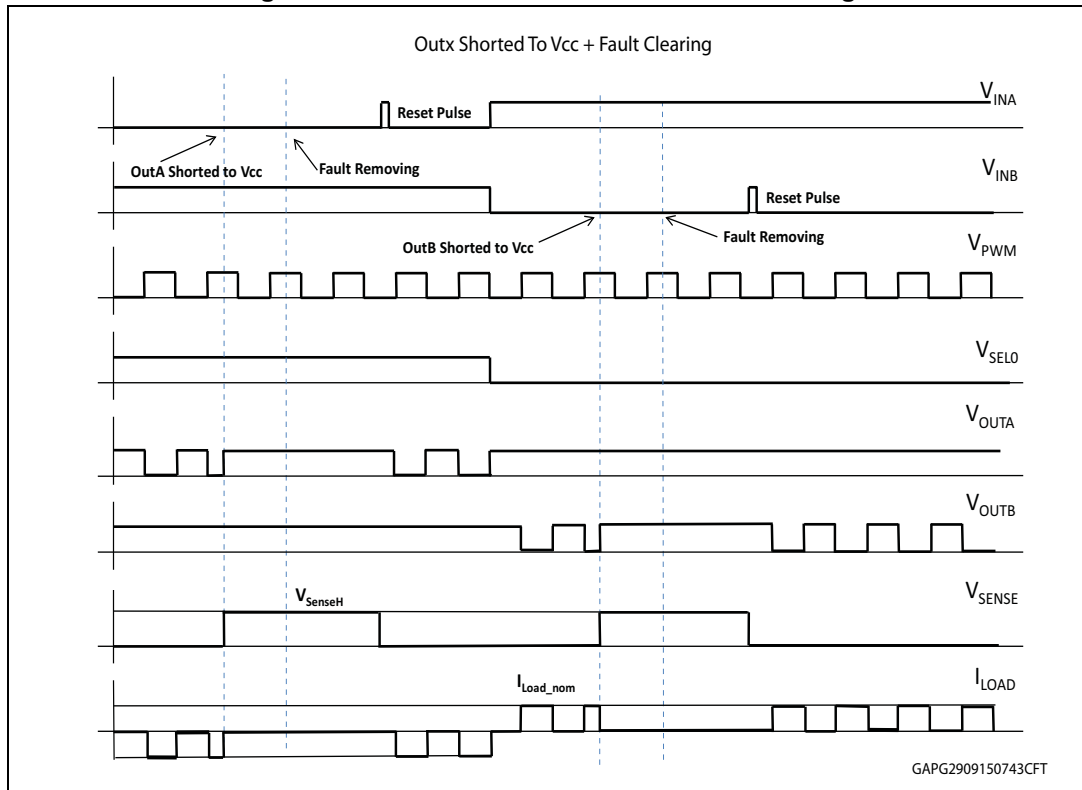

Note: MultiSense_EN=1

Figure 14. Gate driver low side rise time normalized vs C_g = 4.7nF

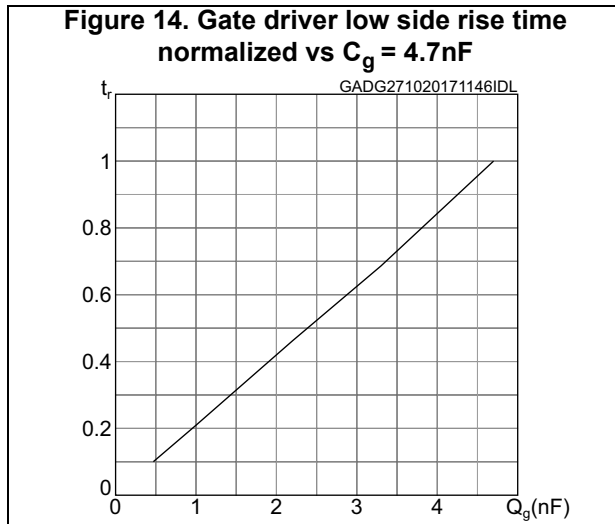
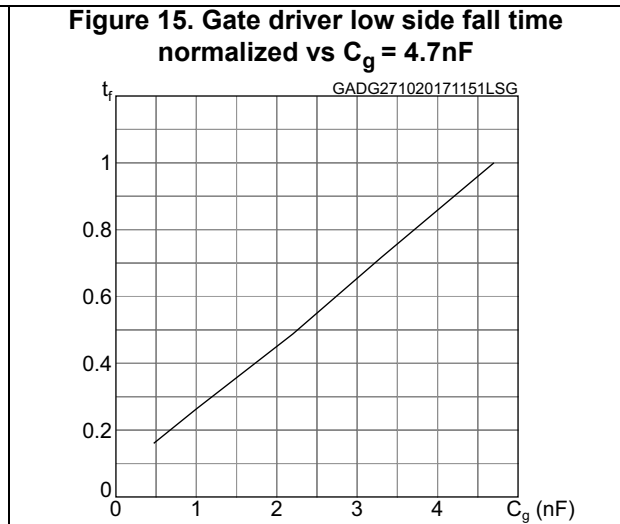

Figure 15. Gate driver low side fall time normalized vs C_g = 4.7nF



3 Protections

3.1 Power limitation (high-side driver)

The basic working principle of this protection consists of an indirect measurement of the junction temperature swing ΔT_j through the direct measurement of the spatial temperature gradient on the device surface in order to automatically shut off the output MOSFET as soon as ΔT_j exceeds the safety level of ΔT_{j_SD} . The protection prevents fast thermal transient effects and, consequently, reduces thermo-mechanical fatigue. When Power Limitation is reached, The device enters in latch mode and generates the Fault Flag on Multisense = VsenseH when the faulty leg diagnostic is selected (please refer to [Table 13](#)).

3.2 Thermal shutdown

In case the junction temperature of the device exceeds the maximum allowed threshold (typically 175°C), the device enters in latch mode and generates the Fault Flag on Multisense = VsenseH (please refer to [Table 13](#)). The concerned high side can be switched ON again as soon as: T_j drops below TTR_HSD, INX is set low for a duration > TLATCH_RST_HS and set high again.

3.3 High-side current limitation

The device is equipped with an output current limiter in order to protect the silicon as well as the other components of the system (e.g. bonding wires, wiring harness, connectors, loads, etc.) from excessive current flow. In case of short circuit, overload or during load power-up, the output current is clamped to a safety level, ILIMH, by operating the output power MOSFET in the active region

3.4 External PowerMOS low side VDS monitoring

The VDS_monitoring function has the ability to sense the OUTPUT Mosfet source voltage and compare it to a predetermined threshold. This threshold is programmable, using an internal reference current IREF_OVL_LSD = 50 μ A (typ.) and an external resistor connected at VREF_OVL_LS external pin.

This protection will be activated when the low side Power Mos is switched ON and its gate is fully charged: to guarantee this condition the function will detect a short to battery event only when PWM = H and after a blanking time tfil_OVL_LS= 2.2 μ s (typ.) starting from PWM rising edge. This feature is present for each LSD leg.

In case of fault conditions caused by Power Limitation or overtemperature or open load/short to VCC in OFF state, the fault is indicated by the MultiSense pin being internally switched to a "current limited" voltage source pulled to level V_{SENSEH}.

4 Typical application schematic

Figure 16. Typical application schematic

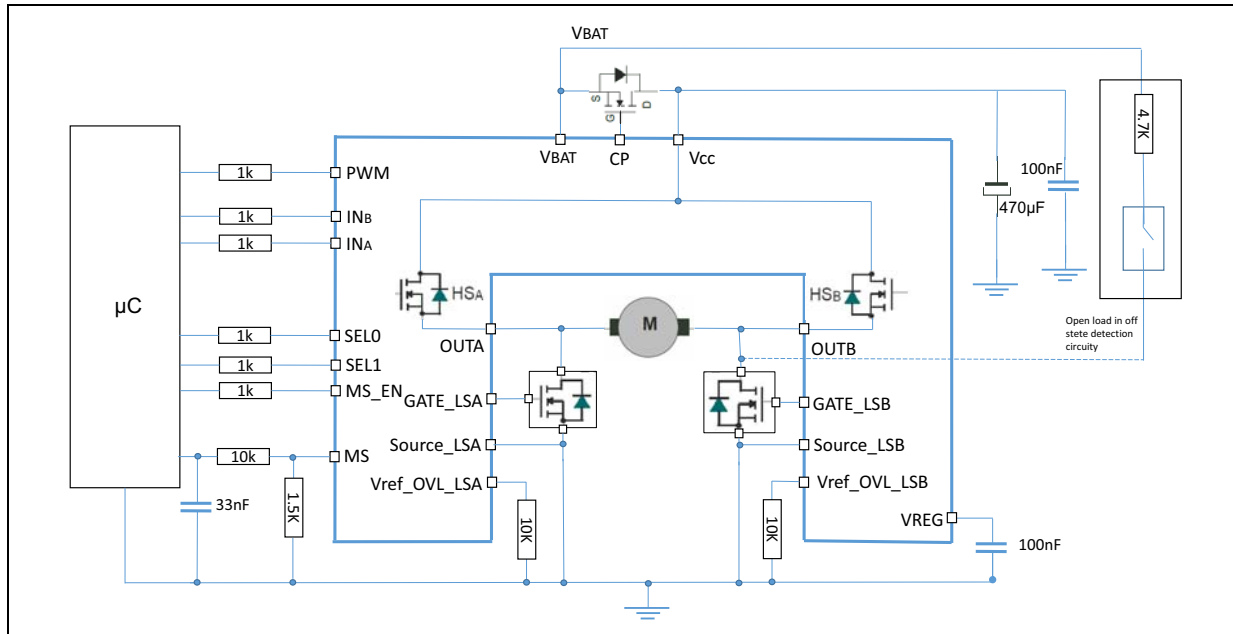

Note: To protect the device against Battery disconnection with energized inductive load when the bridge driver goes into 3-state, suggested $C(V_{CC})$ is:

$$c(V_{CC}) = \frac{E_{motor}}{0.5DV_{CC,max}^2}$$

where:

$E_{motor} = 33.5 \text{ mJ}$;

$DV_{CC,max} = V_{CC_AMR} - V_{CC_max}$;

$V_{CC_AMR} = 38 \text{ V}$;

$V_{CC_max} = 26 \text{ V}$ (V_{CC} at jump start);

$C(V_{CC}) = 470 \mu\text{F}$

5 MultiSense operation

5.1 MultiSense analog monitoring

Diagnostic information on device and load status are provided by an analog output pin (MultiSense) delivering the following signals:

- Current monitor: current mirror of HSDx output current
- VCC monitor: voltage proportional to VCC
- TCASE: voltage proportional to chip temperature

Those signals are routed through an analog multiplexer which is configured and controlled by means of SELx and SEn pins, according to the address map in [Table 12](#).

Figure 17. MultiSense block diagram

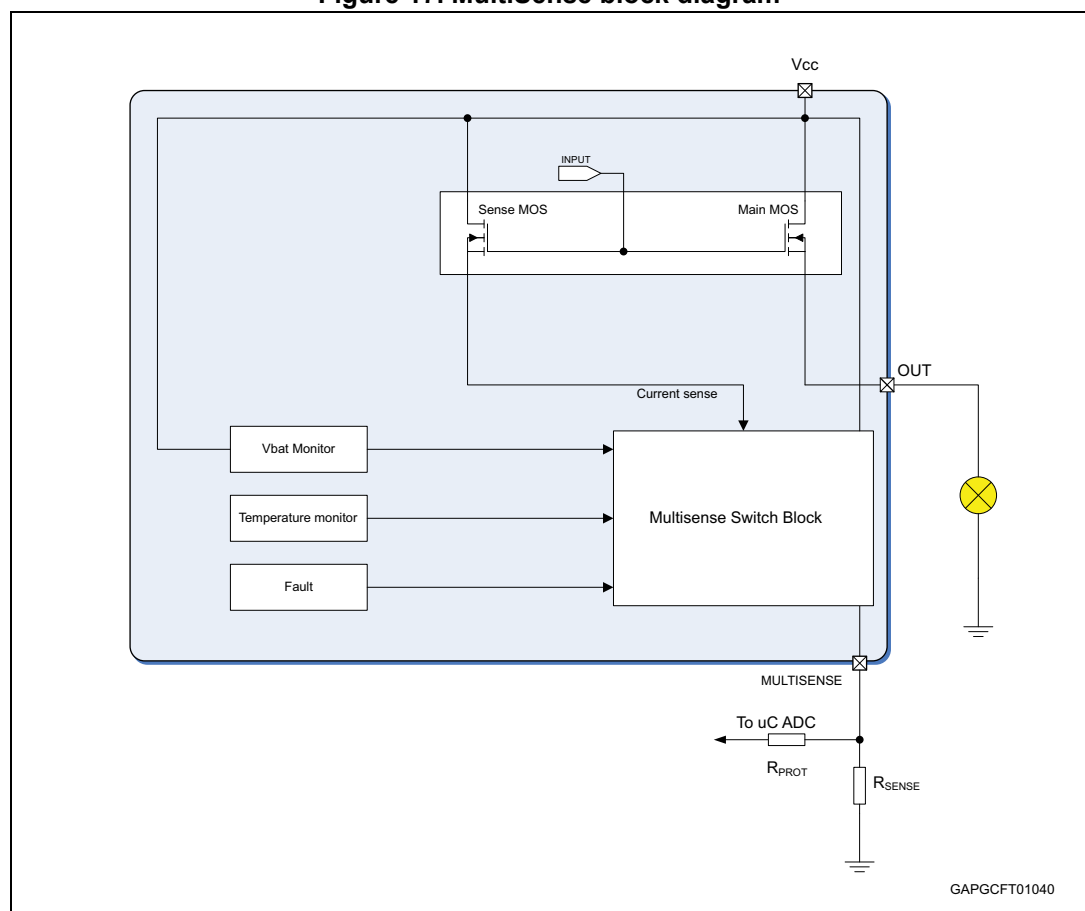

5.2 Multisense diagnostics flag in fault conditions

Multisense pin delivers fixed voltage (VSENSEH) with a certain current capability in case of:

- fault condition on activated high-side triggered by Power Limitation
- fault condition on activated high-side triggered by overtemperature protection
- fault condition on VDS of Low side exceeded threshold

6 VREG and Driver_LS Block

VREG pin is the output of an internal low drop voltage regulator. VREG block is designed to power the driver of external power Mosfet (Driver_LS) and it allows a proper MOS transition.

- VREG out voltage will be VREG=10V if Vbattery > 10V, while VREG = Vbattery if Vbattery < 10V.

An external capacitor C_{REG} = 100 nF connected to the pin VREG is needed to proper polarize the circuit (see [Figure 16](#)).

7 Reverse battery protection

CP pin provides the necessary gate drive for an external n-channel PowerMOS used for reverse polarity protection. The external N-channel Power MOSFET used for the reverse battery protection should have the following characteristics:

- BVdss > 20 V (for a reverse battery of -16 V);
- RDS(on) < 1/3 of H-bridge total RDS(on)
- Standard Logic Gate Driving

8 Open-load detection in off-state

The Open Load (OL) detection in off-state operates when output is deactivated (means INA = INB = PWM=0, or INB together with PWM=0). Open load detection is performed by reading the MultiSense output. External (switched) pull-up resistor has to be used and dimensioned to pull output voltage above the maximum open load detection voltage (VOL MAX) when load is not connected and as well stays below the minimum level (VOL MIN) when load is connected.

When the open load is detected, VsenseH is indicated on Multisense pin, possible conditions are specified in [Table 14](#).

If pull up resistor is applied over switched circuitry, it allows to detect short to VCC from open-load (see [Figure 16](#)).

The RPU value has to be:

$$R_{\text{pull_up}} < \frac{V_{\text{BATTmin}} - V_{\text{OLmax}}}{2 \times I_{\text{L(off2)min}} [@VOLmax]}$$

9 Immunity against transient electrical disturbances

The immunity of the device against transient electrical emissions, conducted along the supply lines and injected into the VCC pin, is tested in accordance with ISO7637-2:2011 (E) and ISO 16750-2:2010.

The related function performance status classification is shown in [Table 15](#).

Test pulses are applied directly to DUT (Device Under Test) both in ON and OFF-state and in accordance to ISO 7637-2:2011(E), chapter 4. The DUT is intended as the present device only, without components and accessed through VCC and GND terminals.

Status II is defined in ISO 7637-1 Function Performance Status Classification (FPSC) as follows: "The function does not perform as designed during the test but returns automatically to normal operation after the test".

Table 15. IISO 7637-2 - electrical transient conduction along supply line

Test pulse 2011(E)	Test pulse severity level with status II functional performance status		Minimum number of pulses or test time	Burst cycle/pulse repetition time		Pulse duration and pulse generator internal impedance
	Level	$U_S^{(1)}$		min.	max.	
1	III	-112 V	500 pulses	0.5 s		2 ms, 10 Ω
2a	III	+55	500 pulses	0.2 s	5 s	50 μ s, 2 Ω
3a	IV	-220 V	1h	90 ms	100 ms	0.1 μ s, 50 Ω
3b	IV	+150 V	1h	90 ms	100 ms	0.1 μ s, 50 Ω
4 ⁽²⁾	IV	-7 V	1 pulse			100 ms, 0.01 Ω
Load dump according to ISO 16750-2:2010						
Test B ⁽³⁾		40 V	5 pulse	1 min		400 ms, 2 Ω

1. U_S is the peak amplitude as defined for each test pulse in ISO 7637-2:2011(E)
2. Test pulse from ISO 7637-2:2004(E)
3. With 40 V external suppressor referred to ground ($-40\text{ }^\circ\text{C} < T_J < 150\text{ }^\circ\text{C}$)

10 Package and PCB thermal data

10.1 PowerSSO-36 thermal data

Figure 18. PowerSSO-36 PCB board

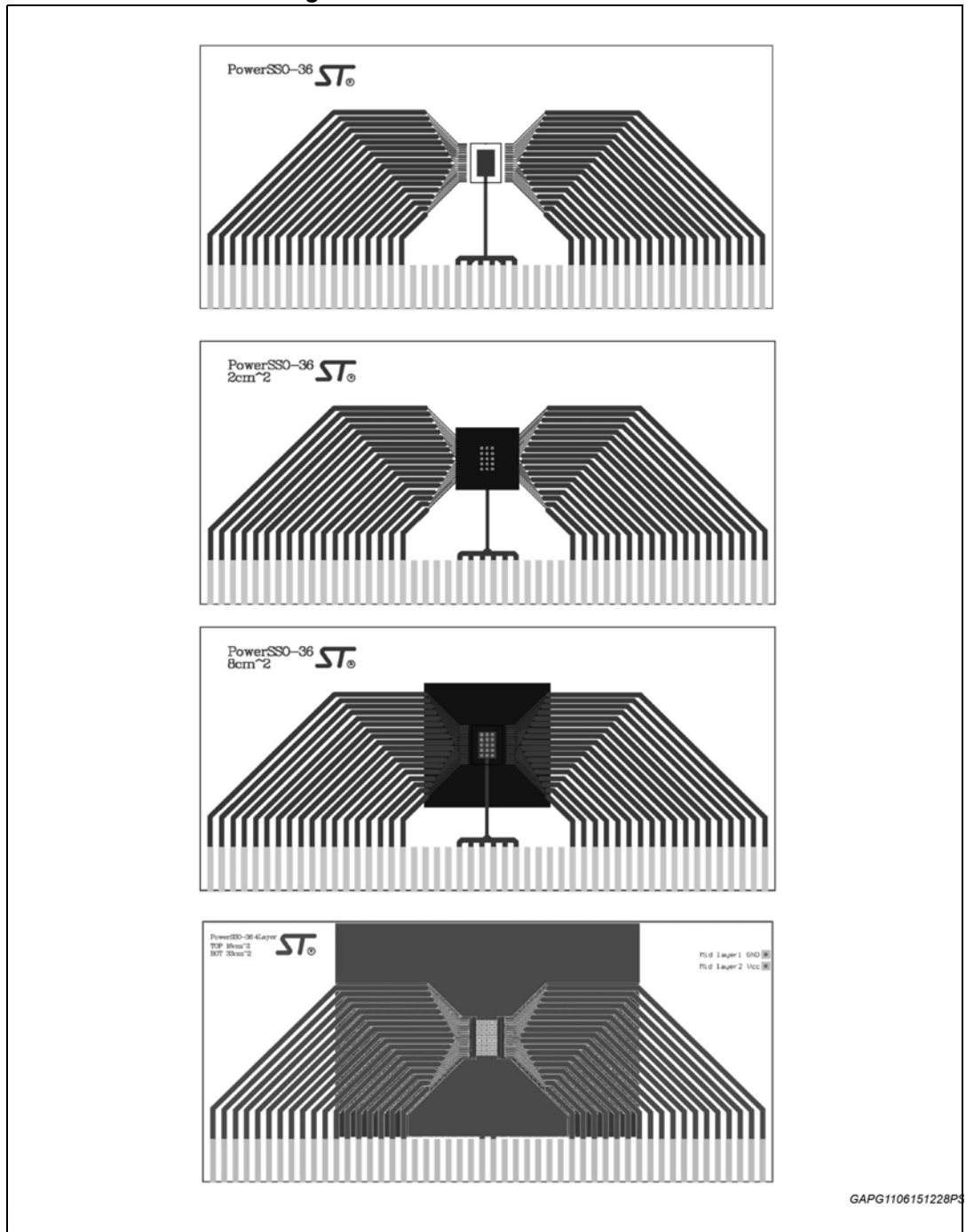
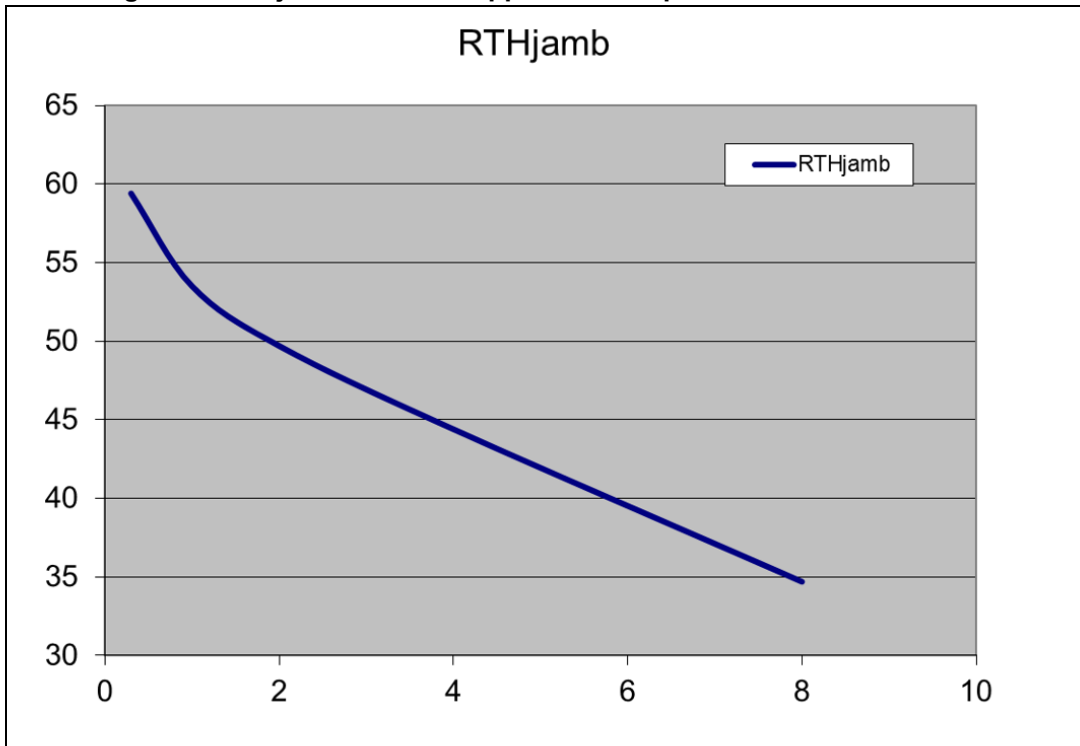

Table 16. PCB properties

Dimension	Value
Board finish thickness	1.6 mm +/- 10%
Board dimension	129 mm x 86 mm
Board material	FR4
Cu thickness (outer layers)	0.070 mm
Cu thickness (inner layers)	0.035 mm
Thermal via separation	1.2 mm
Thermal via diameter	0.3 mm +/- 0.08 mm
Cu thickness on vias	0.025 mm
Footprint dimension	4.1 mm x 6.5 mm

Figure 19. Rthj-amb vs PCB copper area in open box free air condition



Equation 1: pulse calculation formula

$$ZTH\delta = RTH \cdot \delta + ZTHtp (1 - \delta)$$

where $\delta = tP/T$

Figure 20. Thermal fitting model of a double-channel HSD in PowerSSO-36

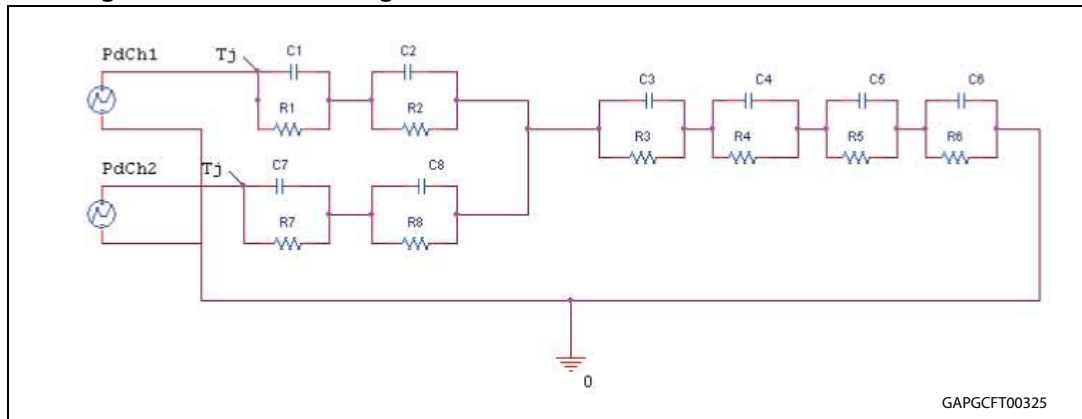

Note: The fitting model is a simplified thermal tool and is valid for transient evolutions where the embedded protections (power limitation or thermal cycling during thermal shutdown) are not triggered.

Figure 21. Thermal impedance junction ambient single pulse

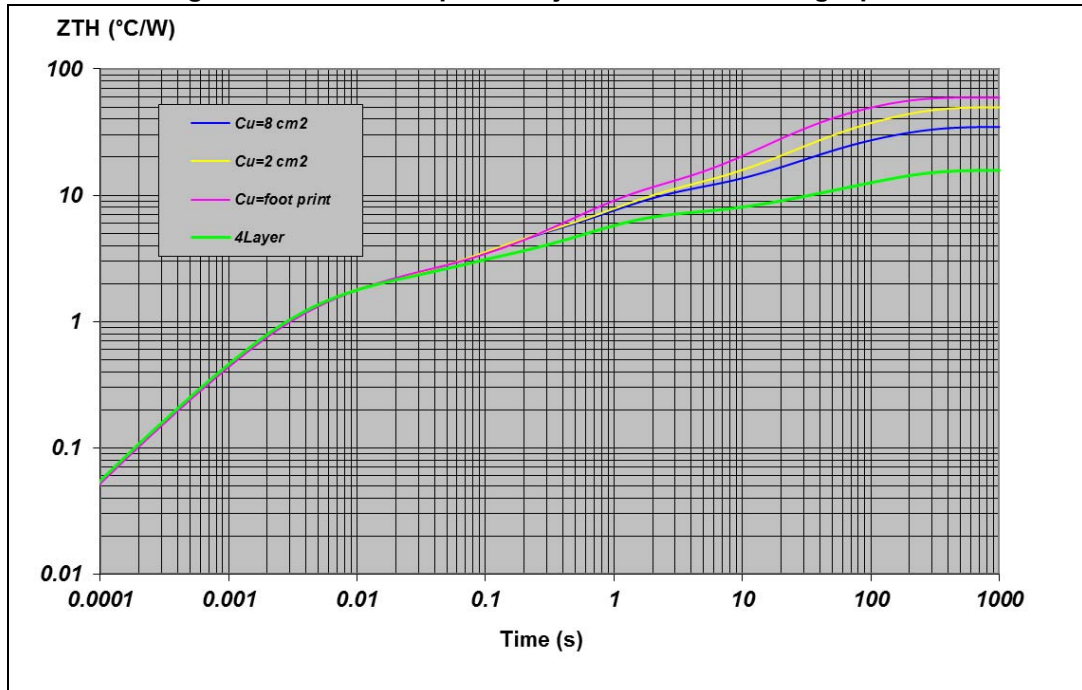

Table 17. Thermal parameters

Area / island	FP	2	8	4L
R1 (°C/W)	0.75			
R2 (°C/W)	1			
R3 (°C/W)	2	2	2	1
R4 (°C/W)	7	6	6	4
R5 (°C/W)	20	14	10	2

Table 17. Thermal parameters (continued)

Area / island	FP	2	8	4L
R6 (°C/W)	30	26	15	7
R7 (°C/W)	0.75			
R8 (°C/W)	1			
C1 (W•s/°C)	0.0027			
C2 (W•s/°C)	0.006			
C3 (W•s/°C)	0.05	0.05	0.05	0.05
C4 (W•s/°C)	0.15	0.2	0.2	0.2
C5 (W•s/°C)	1	2	3	10
C6 (W•s/°C)	3	5	9	18
C7 (W•s/°C)	0.0027			
C8 (W•s/°C)	0.006			

11 Package and packing information

In order to meet environmental requirements, ST offers these devices in different grades of ECOPACK packages, depending on their level of environmental compliance. ECOPACK specifications, grade definitions and product status are available at: www.st.com.

ECOPACK is an ST trademark.

11.1 PowerSSO-36 package information

Figure 22. PowerSSO-36 package dimensions

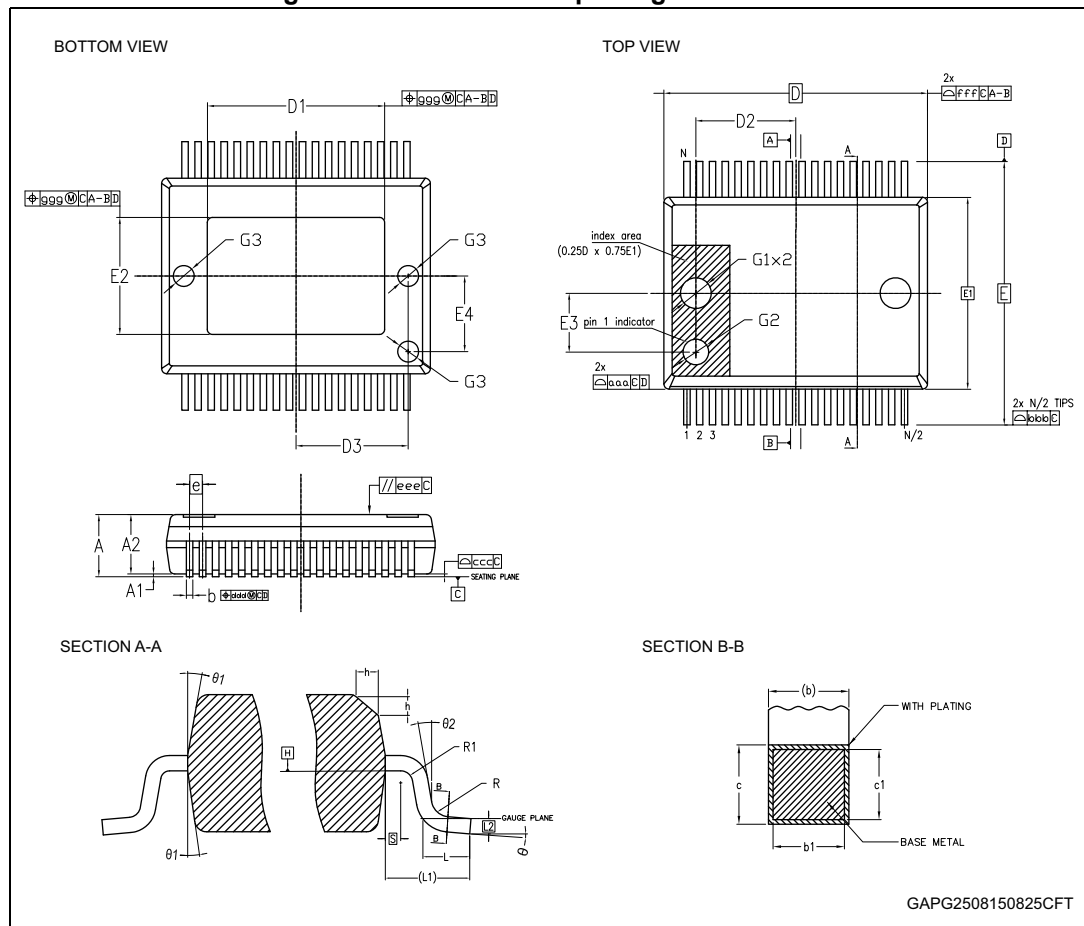

Table 18. PowerSSO-36 (exposed pad) package mechanical data

Ref	Millimeters		
	Min.	Typ.	Max.
Θ	0°	-	8°
$\Theta 1$	5°	-	10°
$\Theta 2$	0°	-	-

Table 18. PowerSSO-36 (exposed pad) package mechanical data (continued)

Ref	Millimeters		
	Min.	Typ.	Max.
A	2.15	-	2.45
A1	0.0	-	0.1
A2	2.15	-	2.35
b	0.18	-	0.32
b1	0.13	0.25	0.3
c	0.23	-	0.32
c1	0.2	0.2	0.3
D ⁽¹⁾	10.30 BSC		
D1	6.9	-	7.5
D2	-	3.65	-
D3	-	4.3	-
e	0.50 BSC		
E	10.30 BSC		
E1 ⁽¹⁾	7.50 BSC		
E2	4.3	-	5.2
E3	-	2.3	-
E4	-	2.9	-
G1	-	1.2	-
G2	-	1	-
G3	-	0.8	-
h	0.3	-	0.4
L	0.55	0.7	0.85
L1	1.40 REF		
L2	0.25 BSC		
N	36		
R	0.3	-	-
R1	0.2	-	-
S	0.25	-	-
Tolerance of form and position			
aaa	0.2		
bbb	0.2		
ccc	0.1		
ddd	0.2		

Table 18. PowerSSO-36 (exposed pad) package mechanical data (continued)

Ref	Millimeters		
	Min.	Typ.	Max.
eee	0.1		
fff	0.2		
ggg	0.15		

1. Dimensions D and E1 do not include mold flash or protrusions. Allowable mold flash or protrusions is '0.25 mm' per side D and '0.15 mm' per side E1. D and E1 are Maximum plastic body size dimensions including mold mismatch.

11.2 PowerSSO-36 packing information

Figure 23. PowerSSO-36 tube shipment (no suffix)

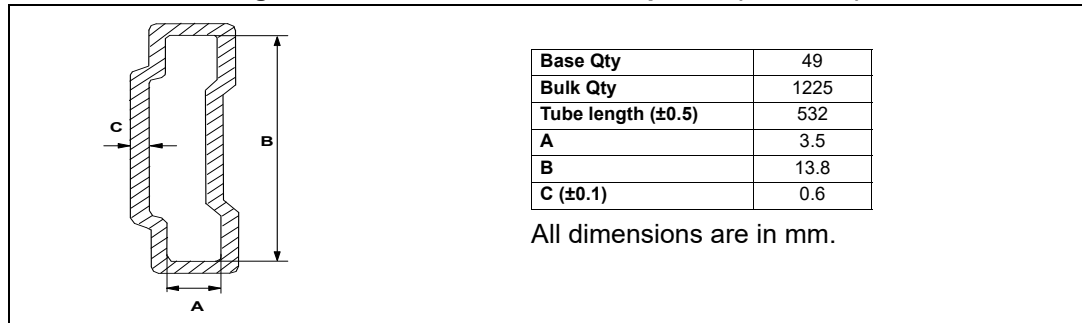
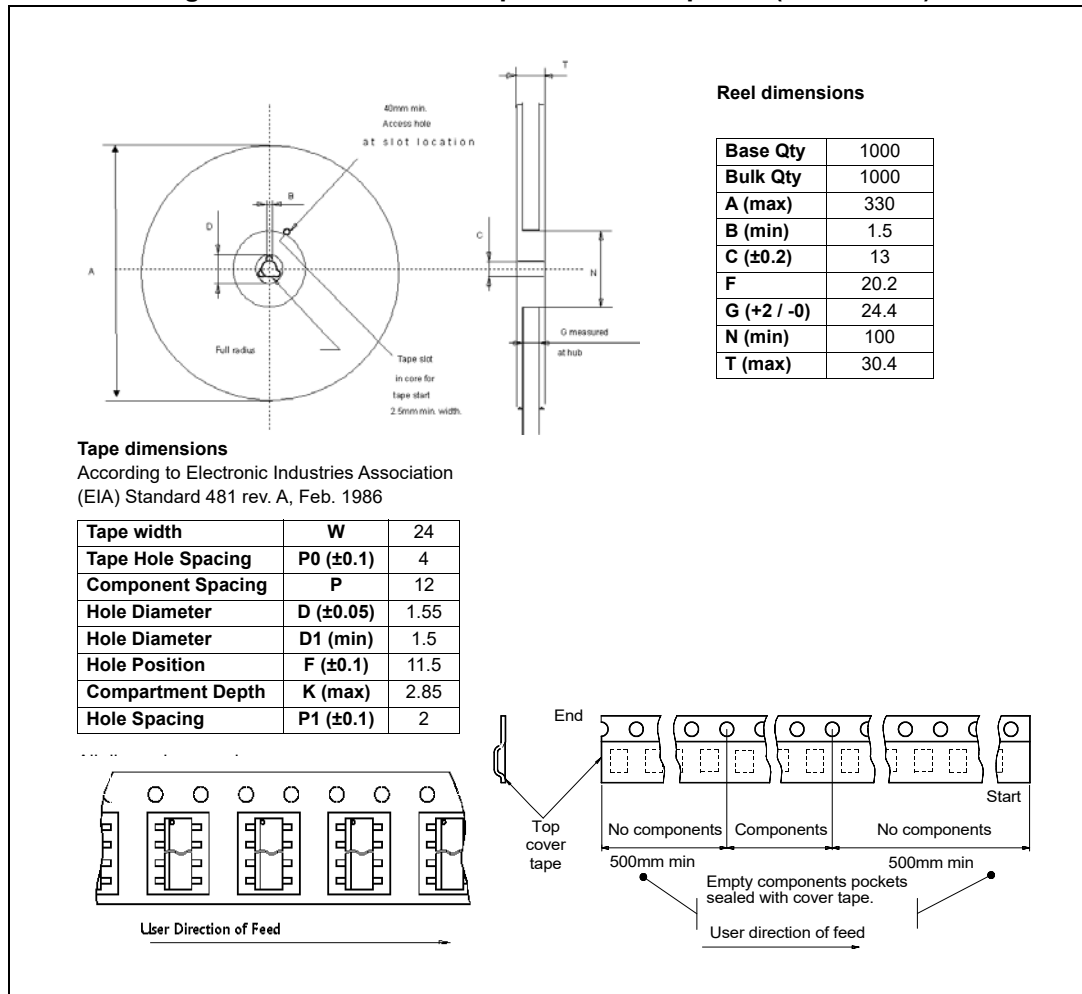
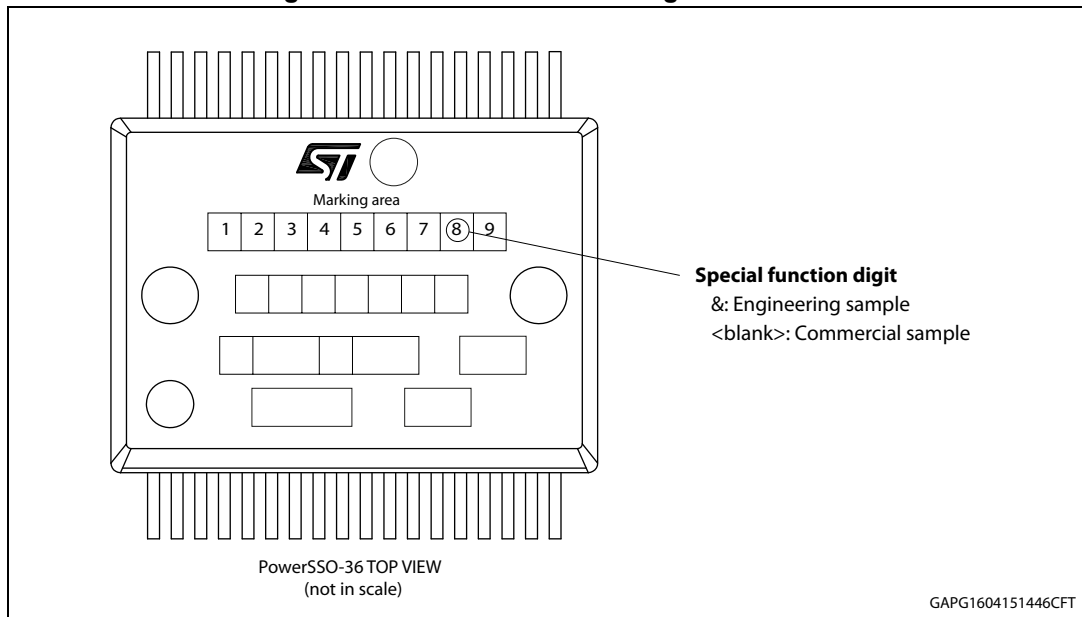

Figure 24. PowerSSO-36 tape and reel shipment (suffix "TR")



11.3 PowerSSO-36 marking information

Figure 25. PowerSSO-36 marking information



Note: Engineering Samples: these samples can be clearly identified by a dedicated special symbol in the marking of each unit. These samples are intended to be used for electrical compatibility evaluation only; usage for any other purpose may be agreed only upon written authorization by ST. ST is not liable for any customer usage in production and/or in reliability qualification trials.

Note: Commercial Samples: fully qualified parts from ST standard production with no usage restrictions.

12 Order codes

Table 19. Device summary

Package	Order codes	
	Tube	Tape and reel
PowerSSO-36	VNHD7008AY	VNHD7008AYTR

13 Revision history

Table 20. Document revision history

Date	Revision	Description of changes
11-Feb-2016	1	Initial release.
14-Jul-2017	2	<p>Updated table in Section: <i>Features</i>.</p> <p>Updated values in <i>Table 3: Absolute maximum ratings</i> and added note.</p> <p>Updated Max. value in <i>Table 4: Thermal data</i>.</p> <p>Updated <i>Table 5: Power section</i>.</p> <p>Updated <i>Table 8: Low-side driver parameters (VCC = 13 V)</i>.</p> <p>Updated <i>Table 9: Protections and diagnostics (7 V < VCC < 18 V; -40 °C < Tj < 150 °C)</i>.</p> <p>Updated <i>Table 10: MultiSense (7 V < VCC < 18 V; -40 °C < Tj < 150 °C)</i>.</p> <p>Added <i>Figure 6: Input reset time for HSD-fault unlatch</i>.</p> <p>Added <i>Section 3: Protections Section 4: Typical application schematic Section 5: MultiSense operation, Section 6: Reverse battery protection, Section 7: Open-load detection in off-state, Section 8: Immunity against transient electrical disturbances, Section 9: Package and PCB thermal data</i>.</p>
03-Nov-2017	3	<p>Updated <i>Figure 1, Table 2: Pin definitions and functions</i>.</p> <p>Added <i>Table 3: Suggested connection for unused and not connected pins</i>.</p> <p>Updated <i>Table 4: Absolute maximum ratings, Table 6: Power section, Table 9: Gate driver for external MOS parameters (VCC = 13 V), Table 10: Protections and diagnostics (7 V < VCC < 18 V; -40 °C < Tj < 150 °C), Table 11: MultiSense (7 V < VCC < 18 V; -40 °C < Tj < 150 °C)</i>.</p> <p>Added <i>Figure 5: Definition of the low-side switching times and Figure 6: Definition of the high-side switching times</i>.</p> <p>Updated <i>Table 13: On-state fault conditions- truth table</i>.</p> <p>Added <i>Figure 14: Gate driver low side rise time normalized vs Cg = 4.7nF and Figure 15: Gate driver low side fall time normalized vs Cg = 4.7nF, Section 5.2: Multisense diagnostics flag in fault conditions and Section 6: VREG and Driver_LS Block, Figure 21: Thermal impedance junction ambient single pulse and Table 17: Thermal parameters</i>.</p> <p>Minor text changes.</p>
11-Dec-2017	4	<p>Document status promoted from target to production data.</p> <p>Updated features in cover page.</p> <p>Minor text changes.</p>

Table 20. Document revision history (continued)

Date	Revision	Description of changes
29-Jan-2018	5	Typo error.
01-Apr-2020	6	Updated Table 4: Absolute maximum ratings (add V_{BAT} and V_{CP} values). Updated Table 10: Protections and diagnostics ($7 V < V_{CC} < 18 V$; $-40\text{ }^{\circ}\text{C} < T_j < 150\text{ }^{\circ}\text{C}$) (changed Min. value in $t_{DEL_OVL_LSD}$; added Min. and Max. value in V_{GS_CP}). Updated Figure 19: $R_{thj-amb}$ vs PCB copper area in open box free air condition . Updated Figure 21: Thermal impedance junction ambient single pulse . Updated Table 17: Thermal parameters .

IMPORTANT NOTICE – PLEASE READ CAREFULLY

STMicroelectronics NV and its subsidiaries (“ST”) reserve the right to make changes, corrections, enhancements, modifications, and improvements to ST products and/or to this document at any time without notice. Purchasers should obtain the latest relevant information on ST products before placing orders. ST products are sold pursuant to ST’s terms and conditions of sale in place at the time of order acknowledgement.

Purchasers are solely responsible for the choice, selection, and use of ST products and ST assumes no liability for application assistance or the design of Purchasers’ products.

No license, express or implied, to any intellectual property right is granted by ST herein.

Resale of ST products with provisions different from the information set forth herein shall void any warranty granted by ST for such product.

ST and the ST logo are trademarks of ST. For additional information about ST trademarks, please refer to www.st.com/trademarks. All other product or service names are the property of their respective owners.

Information in this document supersedes and replaces information previously supplied in any prior versions of this document.

© 2020 STMicroelectronics – All rights reserved