

## Digital PWM System Controller

Check for Samples: [UCD9220](#)

### FEATURES

- Fully Configurable Multi-Output and Multi-Phase Non-Isolated DC/DC PWM Controller
- Controls Up To Two Voltage Rails and Up To Four Phases
- Supports Switching Frequencies Up to 2MHz With 250 ps Duty-Cycle Resolution
- Up To 1mV Closed Loop Resolution
- Hardware-Accelerated, 3-Pole/3-Zero Compensator With Non-Linear Gain for Improved Transient Performance
- Supports Multiple Soft-Start and Soft-Stop Configurations Including Prebias Start-up
- Supports Voltage Tracking, Margining and Sequencing
- Supports Current and Temperature Balancing for Multi-Phase Power Stages
- Supports Phase Adding/Shedding for Multi-Phase Power Stages
- Sync In /Out Pins Align DPWM Clocks Between Multiple UCD9220 Devices
- 12-Bit Digital Monitoring of Power Supply Parameters Including:
  - Input Current and Voltage
  - Output Current and Voltage
  - Temperature at Each Power Stage
- Multiple Levels of Overcurrent Fault Protection:
  - External Current Fault Inputs
  - Analog Comparators Monitor Current Sense Voltage
  - Current Digitally Monitored
- Over and Undervoltage Fault Protection
- Overtemperature Fault Protection
- Enhanced Nonvolatile Memory With Error Correction Code (ECC)
- Device Operates From a Single Supply With an Internal Regulator Controller That Allows Operation Over a Wide Supply Voltage Range

- Supported by Fusion Digital Power™ Designer, a Full Featured PC Based Design Tool to Simulate, Configure, and Monitor Power Supply Performance.

### APPLICATIONS

- Industrial/ATE
- Networking Equipment
- Telecommunications Equipment
- Servers
- Storage Systems
- FPGA, DSP and Memory Power

### DESCRIPTION

The UCD9220 is a multi-rail, multi-phase synchronous buck digital PWM controller designed for non-isolated DC/DC power applications. This device integrates dedicated circuitry for DC/DC loop management with flash memory and a serial interface to support configuration, monitoring and management.

The UCD9220 was designed to provide a wide variety of desirable features for non-isolated DC/DC converter applications while minimizing the total system component count by reducing external circuits. The solution integrates multi-loop management with sequencing, margining, tracking and intelligent phase management to optimize for total system efficiency. Additionally, loop compensation and calibration are supported without the need to add external components.

To facilitate configuring the device, the Texas Instruments Fusion Digital Power™ Designer is provided. This PC based Graphical User Interface offers an intuitive interface to the device. This tool allows the design engineer to configure the system operating parameters for the application, store the configuration to on-chip non-volatile memory and observe both frequency domain and time domain simulations for each of the power stage outputs.

TI has also developed multiple complementary power stage solutions – from discrete drives in the UCD7k family to fully tested power train modules in the PTD family. These solutions have been developed to complement the UCD9k family of system power controllers.



Please be aware that an important notice concerning availability, standard warranty, and use in critical applications of Texas Instruments semiconductor products and disclaimers thereto appears at the end of this data sheet.

Fusion Digital Power, Auto-ID are trademarks of Texas Instruments.



This integrated circuit can be damaged by ESD. Texas Instruments recommends that all integrated circuits be handled with appropriate precautions. Failure to observe proper handling and installation procedures can cause damage.

ESD damage can range from subtle performance degradation to complete device failure. Precision integrated circuits may be more susceptible to damage because very small parametric changes could cause the device not to meet its published specifications.

### ORDERING INFORMATION<sup>(1)</sup>

OPERATING TEMPERATURE RANGE, T <sub>A</sub>	ORDERABLE PART NUMBER	PIN COUNT	SUPPLY	PACKAGE	TOP SIDE MARKING
-40°C to 110°C	UCD9220RGZR	48-pin	Reel of 2500	QFN	UCD9220
	UCD9220RGZT	48-pin	Reel of 250	QFN	UCD9220

(1) For the most current package and ordering information, see the Package Option Addendum at the end of this document, or see the TI web site at [www.ti.com](http://www.ti.com).

## ELECTRICAL SPECIFICATIONS

### ABSOLUTE MAXIMUM RATINGS<sup>(1)</sup>

	VALUE	UNIT
Voltage applied at V33D to DGND1	-0.3 to 3.8	V
Voltage applied at V33A to AGND	-0.3 to 3.8	V
Voltage applied to any pin <sup>(2)</sup>	-0.3 to 3.8	V
Storage temperature (T <sub>STG</sub> )	-40 to 150	°C

(1) Stresses beyond those listed under *absolute maximum ratings* may cause permanent damage to the device. These are stress ratings only and functional operation of the device at these or any other conditions beyond those indicated under *recommended operating conditions* is not implied. Exposure to absolute-maximum-rated conditions for extended periods may affect device reliability.

(2) All voltages referenced to GND.

### RECOMMENDED OPERATING CONDITIONS

Over operating free-air temperature range (unless otherwise noted).

	MIN	NOM	MAX	UNIT
V Supply voltage during operation, V33D, V33A	3	3.3	3.6	V
T <sub>A</sub> <sup>(1)</sup> Operating free-air temperature range	-40		110	°C
T <sub>J</sub> <sup>(1)</sup> Junction temperature			125	°C

(1) When operating, the UCD9220's typical power consumption causes a 15 °C temperature rise from ambient.

**ELECTRICAL CHARACTERISTICS**

PARAMETER		TEST CONDITIONS	MIN	NOM	MAX	UNIT
<b>SUPPLY CURRENT</b>						
$I_{V33A}$	Supply current	$V_{33A} = 3.3\text{ V}$		8	15	mA
$I_{V33D}$		$V_{33D} = 3.3\text{ V}$		42	55	
$I_{V33D}$		$V_{33D} = 3.3\text{ V}$ while storing configuration parameters in flash memory		52	65	
<b>INTERNAL REGULATOR CONTROLLER INPUTS/OUTPUTS</b>						
$V_{33}$	3.3-V linear regulator	Emitter of NPN transistor	3.25	3.3	3.6	V
$V_{33FB}$	3.3-V linear regulator feedback			4	4.6	
$I_{V33FB}$	Series pass base drive	$V_{IN} = 12\text{ V}$ ; current into the pin		10		mA
Beta	Series NPN pass device		40			
<b>EXTERNALLY SUPPLIED 3.3 V POWER</b>						
$V_{33D}$	Digital 3.3-V power	$T_A = 25^\circ\text{C}$	3.13		3.6	V
$V_{33A}$	Analog 3.3-V power	$T_A = 25^\circ\text{C}$	3.13		3.6	V
<b>ERROR AMPLIFIER INPUTS EAPn, EANn</b>						
$V_{CM}$	Common mode voltage each pin		-0.15		1.848	V
$V_{DIFF}$	Differential Voltage Range		-0.25 6		1.998	V
$V_{ERROR}$	Internal error Voltage range	AFE_GAIN field of CLA_GAINS = 0 <sup>(1)</sup>	-256		248	mV
EAP-EAN	Error voltage digital resolution	AFE_GAIN field of CLA_Gains = 3		1		mV
$R_{EA}$	Input Impedance	Ground reference	0.5	1.5	3	MΩ
$I_{OFFSET}$	Input offset current	1 kΩ source impedance	-5		5	μA
<b>VREF DAC</b>						
$V_{REF}$	Reference voltage setpoint		0		1.6	V
$V_{REFRES}$	Reference voltage resolution			1.56		mV
<b>ANALOG INPUTS CS-1A, CS-1B, CS-2A, CS-3A, <math>V_{IN}/I_{IN}</math>, Temperature, ADDR-0, ADDR-1, <math>V_{track}</math>, ADCref</b>						
$I_{BIAS}$	Bias current for PMBus Addr pins		9		11	μA
$V_{ADDR\_OPEN}$	Voltage indicating open pin	ADDR-0, ADDR-1 open	2.226			V
$V_{ADDR\_SHORT}$	Voltage indicating shorted pin	ADDR-0, ADDR-1 short to ground			0.097	V
$V_{ADC\_RANGE}$	Measurement range for voltage monitoring	Inputs: $V_{IN}/I_{IN}$ , $V_{track}$ , $V_{temperature}$ CS-1A, CS-1B, CS-2A, CS-3A	0		2.5	V
$V_{OC\_THRS}$	Overcurrent comparator threshold voltage range	Inputs: CS-1A, CS-1B, CS-2A, CS-3A	0.032		2	V
$V_{OC\_RES}$	Overcurrent comparator threshold voltage resolution	Inputs: CS-1A, CS-1B, CS-2A, CS-3A		31.25		mV
ADCref	External Reference input		1.8		V33A	V
$Temp_{internal}$	Int. temperature sense accuracy	Over range from 0°C to 125°C	-5		5	°C
INL	ADC integral nonlinearity		-2.5		2.5	mV
$I_{lkq}$	Input leakage current	3V applied to pin			100	nA
$R_{IN}$	Input impedance	Ground reference	8			MΩ
$C_{IN}$	Current Sense Input capacitance				10	pF

(1) See the [UCD92xx PMBus Command Reference](#) for the description of the AFE\_GAIN field of CLA\_GAINS command.

**ELECTRICAL CHARACTERISTICS (continued)**

PARAMETER		TEST CONDITIONS	MIN	NOM	MAX	UNIT
<b>DIGITAL INPUTS/OUTPUTS</b>						
$V_{OL}$	Low-level output voltage	$I_{OL} = 6 \text{ mA}^{(2)}$ , $V_{V33D} = 3 \text{ V}$			DGND1 +0.25	V
$V_{OH}$	High-level output voltage	$I_{OH} = -6 \text{ mA}^{(3)}$ , $V_{V33D} = 3 \text{ V}$	$V_{V33D}$ -0.6V			V
$V_{IH}$	High-level input voltage	$V_{V33D} = 3 \text{ V}$	2.1		3.6	V
$V_{IL}$	Low-level input voltage	$V_{V33D} = 3.5 \text{ V}$			1.1	V
<b>SYSTEM PERFORMANCE</b>						
$V_{Ref}$	Setpoint Reference Accuracy	$V_{ref}$ commanded to be 1V, at 25°C AFEgain = 4, 1V input to EAP/N measured at output of the EADC <sup>(4)</sup>	-10		10	mV
	Setpoint Reference Accuracy over temperature	-40°C to 125°C	-20		20	mV
$V_{DiffOffset}$	Differential offset between gain settings	AFEgain = 4 compared to AFEgain = 1, 2, or 8	-4		4	mV
$t_{Delay}$	Digital Compensator Delay <sup>(5)</sup>		240		240 + 1 switching period	ns
$F_{SW}$	Switching Frequency		15.26 0		2000	kHz
Duty	Max and Min Duty Cycle	Configured via PMBus	0%		100%	
$V_{33Slew}$	$V_{33}$ slew rate	$V_{33}$ slew rate between 2.3 V and 2.9 V. $V_{33A} = V_{33D}$	0.25			V/ms
$t_{retention}$	Retention of configuration parameters	$T_J = 25^\circ\text{C}$	100			Years
Write_Cycles	Number of nonvolatile erase/write cycles	$T_J = 25^\circ\text{C}$	20			K cycles

(2) The maximum  $I_{OL}$ , for all outputs combined, should not exceed 12 mA to hold the maximum voltage drop specified.

(3) The maximum  $I_{OH}$ , for all outputs combined, should not exceed 48 mA to hold the maximum voltage drop specified.

(4) With default device calibration. PMBus calibration can be used to improve the regulation tolerance.

(5) Time from close of error ADC sample window to time when digitally calculated control effort (duty cycle) is available. This delay must be accounted for when calculating the system dynamic response. Includes EADC conversion time.

**ADC MONITORING INTERVALS AND RESPONSE TIMES**

The ADC operates in a continuous conversion sequence that measures each rail's output voltage, each power stage's output current, plus four other variables (one external temperature, Internal temperature, input voltage or current and tracking input voltage). The length of the sequence is determined by the number of output rails (NumRails) and total output power stages (NumPhases) configured for use. The time to complete the monitoring sampling sequence is give by the formula:

$$t_{ADC\_SEQ} = t_{ADC} \times (\text{NumRAILS} + \text{NumPHASE} + 4) \quad (1) \quad (1)$$

PARAMETER		TEST CONDITIONS	MIN	TYP	MAX	UNIT
$t_{ADC}$	ADC single-sample time			3.84		$\mu\text{s}$
$t_{ADC\_SEQ}$	ADC sequencer interval	Min = 1 Rail + 1 Phase + 4 = 6 samples Max = 2 Rails + 4 Phases + 4 = 10 samples	23.04		38.4+1 switching period	$\mu\text{s}$

The most recent ADC conversion results are periodically converted into the proper measurement units (volts, amperes, degrees), and each measurement is compared to its corresponding fault and warning limits. The monitoring operates asynchronously to the ADC, at intervals shown in the table below.

PARAMETER	TEST CONDITIONS	MIN	TYP	MAX	UNIT
t <sub>Vout</sub>	Output voltage monitoring interval		200		μs
t <sub>Iout</sub>	Output current monitoring interval		200 × N <sub>Rails</sub>		μs
t <sub>Vin</sub>	Input voltage monitoring interval		2		ms
t <sub>Iin</sub>	Input current monitoring interval		2		ms
t <sub>TEMP</sub>	Temperature monitoring interval	25	25 × number of phases	100	ms
t <sub>Ibal</sub>	Output current balancing interval		2		ms

Because the ADC sequencer and the monitoring comparisons are asynchronous to each other, the response time to a fault condition depends on where the event occurs within the monitoring interval and within the ADC sequence interval. Once a fault condition is detected, some additional time is required to determine the correct action based on the FAULT\_RESPONSE code, and then to perform the appropriate response. The following table lists the worst-case fault response times.

PARAMETER	TEST CONDITIONS	MAX TIME	UNIT
t <sub>OVF</sub> , t <sub>UVF</sub>	Over-voltage/under-voltage fault response time during normal operation	300	μs
t <sub>OVF</sub> , t <sub>UVF</sub>	Over-voltage/under-voltage fault response time, during data logging	800	μs
t <sub>OVF</sub> , t <sub>UVF</sub>	Over-voltage/under-voltage fault response time, when tracking or sequencing enable	400	μs
t <sub>OCF</sub> , t <sub>UCF</sub>	Over-current/under-current fault response time during normal operation	100 + (600 × N <sub>Rails</sub> ) <sup>(2)</sup>	μs
t <sub>OCF</sub> , t <sub>UCF</sub>	Over-current/under-current fault response time, during data logging	600 + (600 × N <sub>Rails</sub> )	μs
t <sub>OCF</sub> , t <sub>UCF</sub>	Over-current/under-current fault response time, when tracking or sequencing enable	300 + (600 × N <sub>Rails</sub> )	μs
t <sub>OTF</sub>	Over-temperature fault response time	5	s

- (1) During a STORE\_DEFAULT\_ALL command, which stores the entire configuration to nonvolatile memory, the fault detection latency can be up to 10 ms.
- (2) Because the current measurement is averaged with a smoothing filter, the response time to an Overcurrent condition depends on a combination of the time constant (τ) from Table 5, the recent measurement history, and how much the measured value exceeds the overcurrent limit.

## HARDWARE FAULT DETECTION LATENCY

The controller contains hardware fault detection circuits that are independent of the ADC monitoring sequencer.

PARAMETER	TEST CONDITIONS	MAX TIME	UNIT
t <sub>FLT</sub>	Time to disable DPWM output based on corresponding active FLT pin	15 + 3 × NumPhases	μs
t <sub>CLF</sub>	Time to disable the first DPWM output based on internal analog comparator fault	4	Switch Cycles
	Time to disable all remaining DPWM and SRE outputs configured for the voltage rail after an internal analog comparator fault.	10 + 3 × NumPhases	μs

## PMBUS/SMBUS/I<sup>2</sup>C

The timing characteristics and timing diagram for the communications interface that supports I<sup>2</sup>C, SMBus and PMBus are shown below.

## I<sup>2</sup>C/SMBus/PMBus Timing Characteristics

$T_A = -40^{\circ}\text{C}$  to  $85^{\circ}\text{C}$ ,  $3\text{V} < V_{33\text{D}} < 3.6\text{V}$ , typical values at  $T_A = 25^{\circ}\text{C}$

PARAMETER		TEST CONDITIONS	MIN	TYP	MAX	UNIT
$f_{\text{SMB}}$	SMBus/PMBus operating frequency	Slave mode; SMBC 50% duty cycle	10	1000		kHz
$f_{\text{I}^2\text{C}}$	IC operating frequency	Slave mode; SCL 50% duty cycle	10	1000		kHz
$t_{(\text{BUF})}$	Bus free time between start and stop		4.7			$\mu\text{s}$
$t_{(\text{HD:STA})}$	Hold time after (repeated) start		0.26			$\mu\text{s}$
$t_{(\text{SU:STA})}$	Repeated start setup time		0.26			$\mu\text{s}$
$t_{(\text{SU:STO})}$	Stop setup time		0.26			$\mu\text{s}$
$t_{(\text{HD:DAT})}$	Data hold time	Receive mode	0			ns
$t_{(\text{SU:DAT})}$	Data setup time		50			ns
$t_{(\text{TIMEOUT})}$	Error signal/detect	See (1)			35	$\mu\text{s}$
$t_{(\text{LOW})}$	Clock low period		0.5			$\mu\text{s}$
$t_{(\text{HIGH})}$	Clock high period	See (2)	0.26	50		$\mu\text{s}$
$t_{(\text{LOW:SEXT})}$	Cumulative clock low slave extend time	See (3)			25	$\mu\text{s}$
$t_{\text{FALL}}$	Clock/data fall time	See (4)			120	ns
$t_{\text{RISE}}$	Clock/data rise time	See (5)			120	ns

- (1) The UCD9220 times out when any clock low exceeds  $t_{(\text{TIMEOUT})}$ .
- (2)  $t_{(\text{HIGH})}$ , max, is the minimum bus idle time.  $\text{SMBC} = \text{SMBD} = 1$  for  $t > 50$  ms causes reset of any transaction involving UCD9220 that is in progress. This specification is valid when the  $\text{NC\_SMB}$  control bit remains in the default cleared state ( $\text{CLK}[0]=0$ ).
- (3)  $t_{(\text{LOW:SEXT})}$  is the cumulative time a slave device is allowed to extend the clock cycles in one message from initial start to the stop.
- (4) Rise time  $t_{\text{RISE}} = V_{\text{ILMAX}} - 0.15$  to  $(V_{\text{IHMIN}} + 0.15)$
- (5) Fall time  $t_{\text{FALL}} = 0.9 V_{33\text{D}}$  to  $(V_{\text{ILMAX}} - 0.15)$

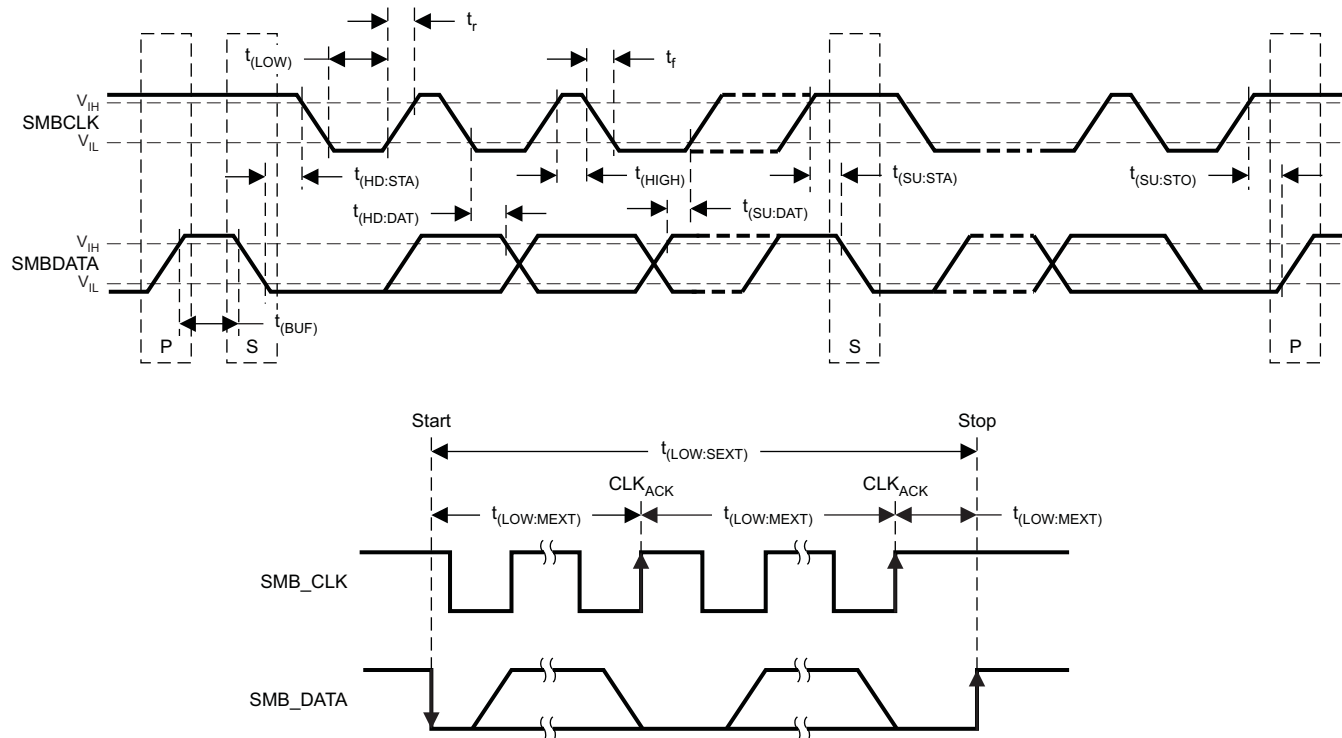
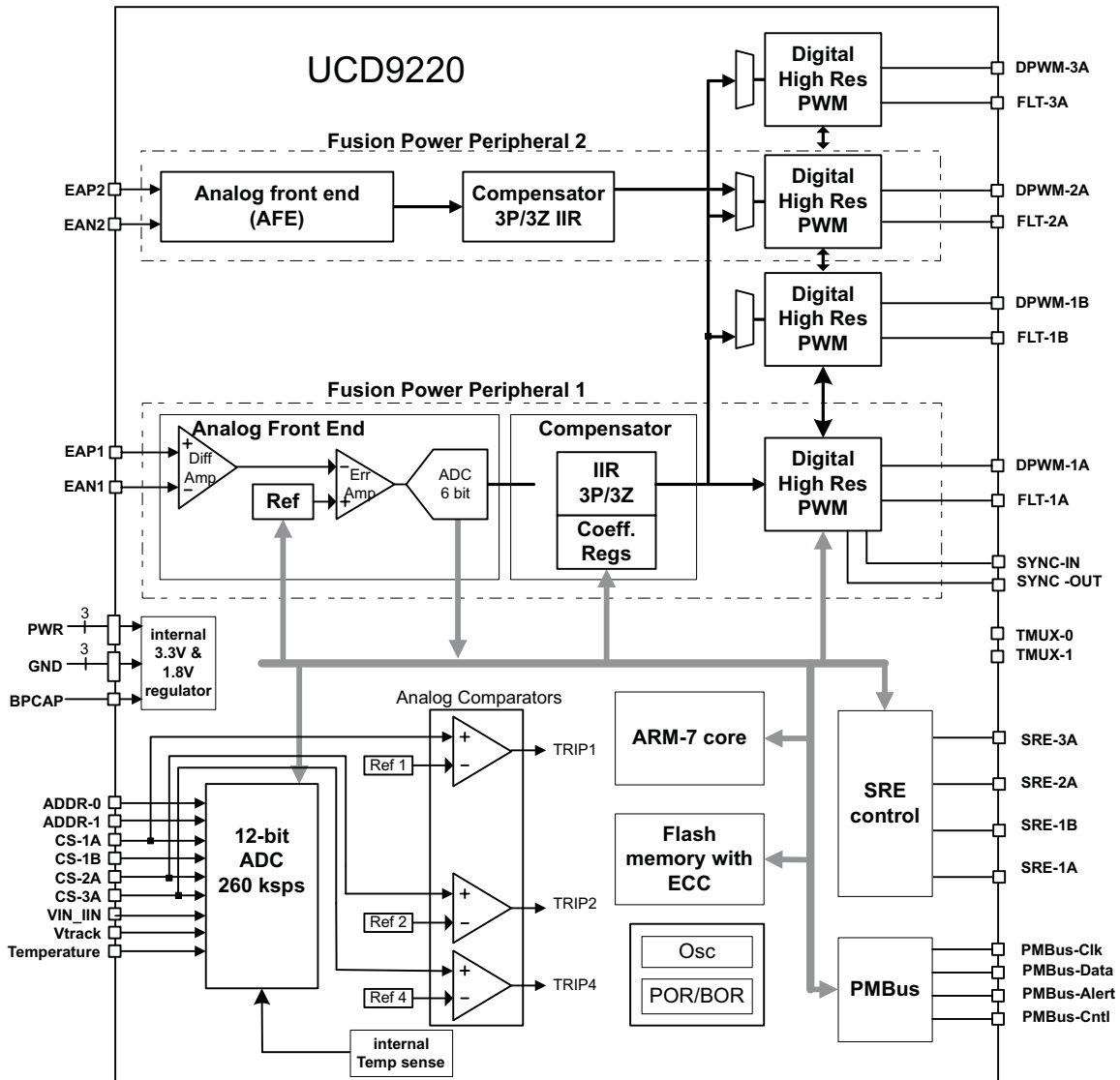
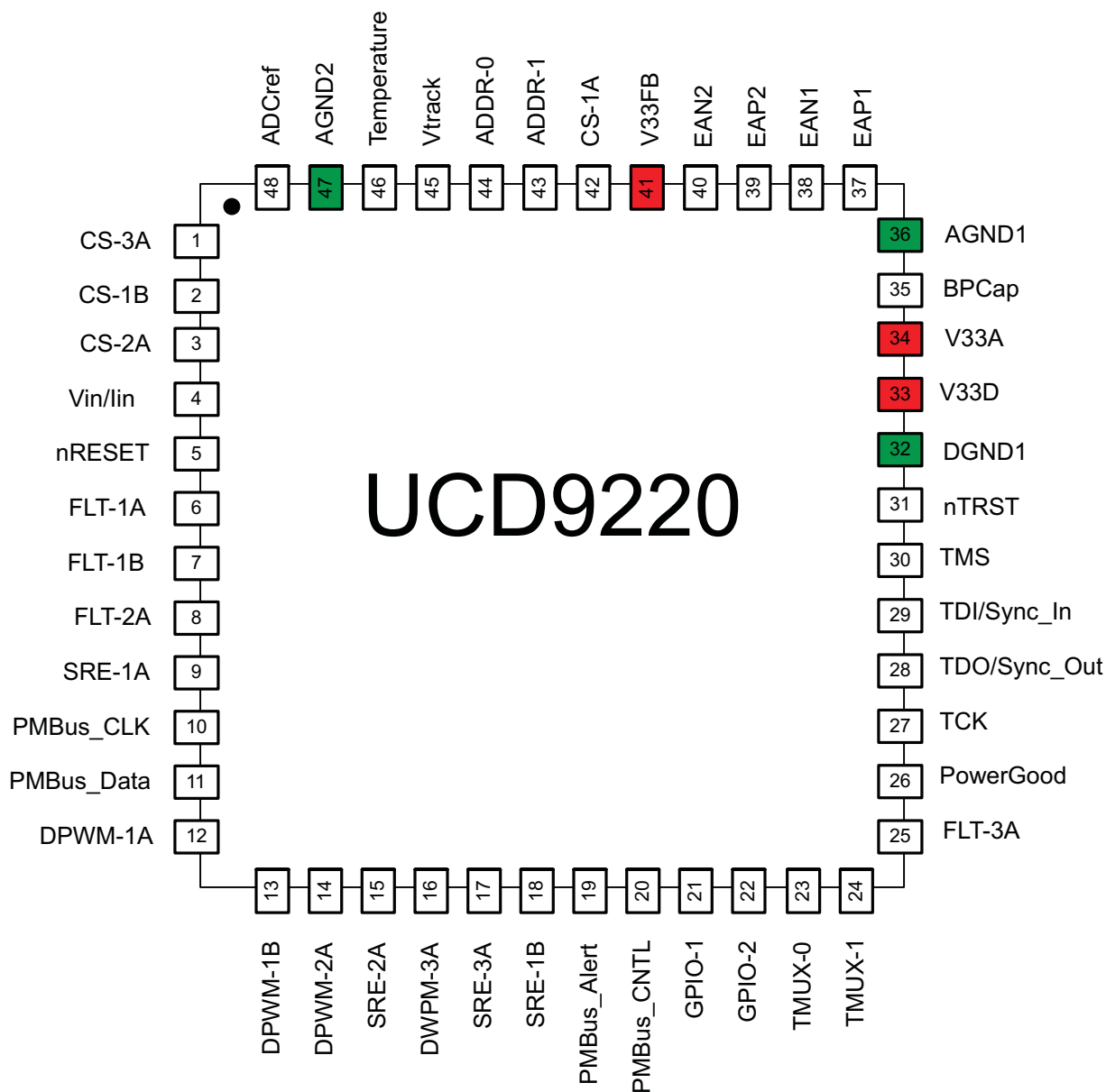

Figure 1. I<sup>2</sup>C/SMBus/PMBus Timing in Extended Mode Diagram

FUNCTIONAL BLOCK DIAGRAM



**PIN ASSIGNMENT**



**Figure 2. UCD9220 Pin Assignment**

The UCD9220 is available in a plastic 48-pin QFN package (RGZ).

TYPICAL APPLICATION SCHEMATIC

Figure 3 shows the UCD9220 power supply controller as part of a system that provides the regulation of two independent power supplies. The loop for each power supply is created by the respective voltage outputs feeding into the differential voltage error ADC (EADC) inputs, and completed by DPWM outputs feeding into the gate drivers for each power stage (PTD modules in this example).

The  $\pm V_{sense}$  rail signals must be routed to the EAp/EAn input that matches the number of the lowest DPWM configured as part of the rail. (See more detail on page 19, "Flexible Rail/Power Stage Configuration".)

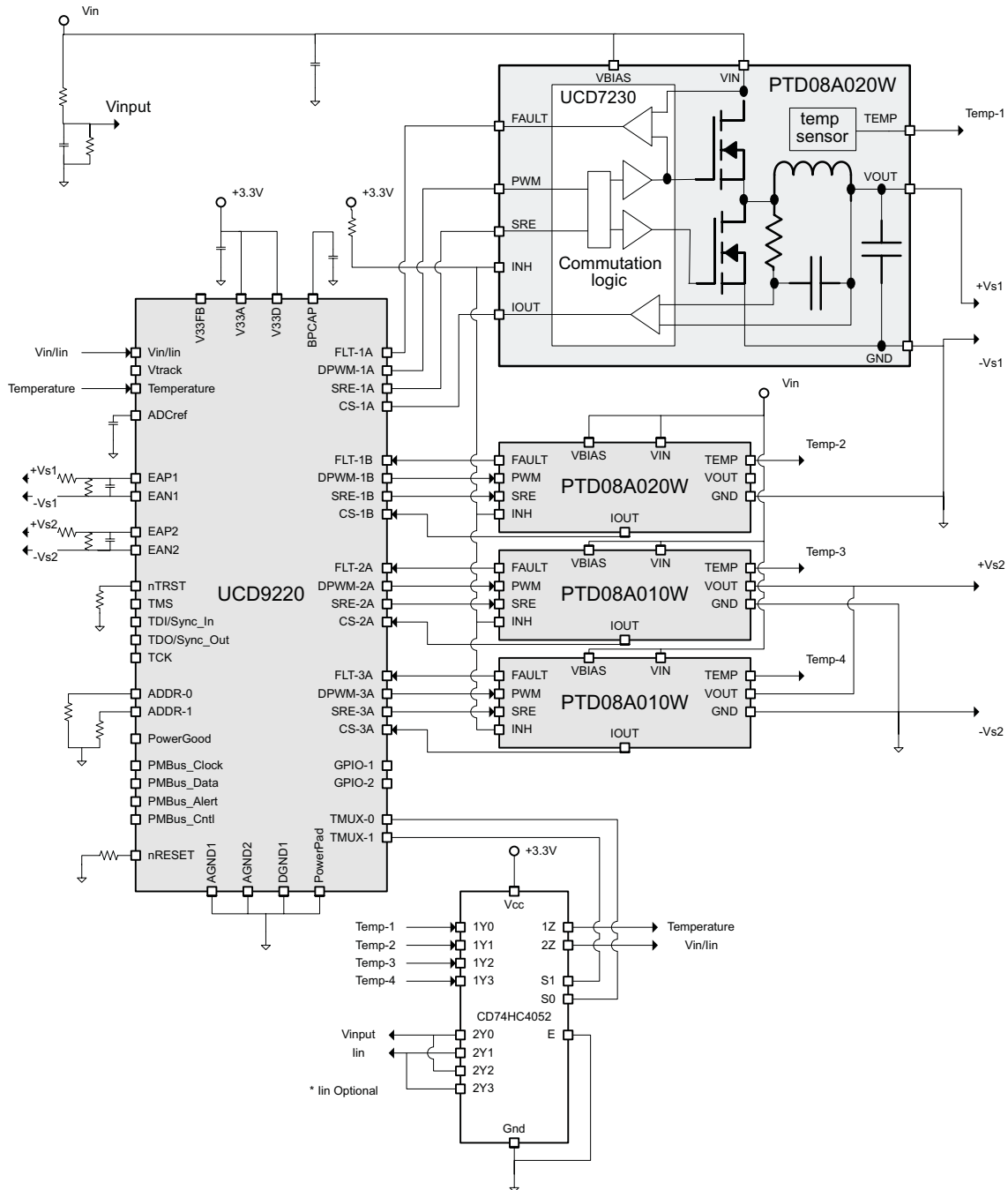

Figure 3. Typical Application Schematic

### PIN DESCRIPTIONS

PIN		I/O	DESCRIPTION
NO.	NAME		
1	CS-3A	Input	Power stage 3A current sense input and input to analog comparator 4
2	CS-1B	Input	Power stage 1B current sense input and input to analog comparator 2
3	CS-2A	Input	Power stage 2A current sense input and input to analog comparator 3
4	V <sub>in</sub> /I <sub>in</sub>	Input	Input supply sense, alternates between V <sub>in</sub> and I <sub>in</sub>
5	nRESET	Input	Active low device reset input pullup to 3.3V with a 10 kΩ resistor
6	FLT-1A	Input	External fault input 1A, active high
7	FLT-1B	Input	External fault input 1B, active high
8	FLT-2A	Input	External fault input 2A, active high
9	SRE-1A	Output	Synchronous rectifier enable 1A, active high
10	PMBus_Clk	Input/Output	PMBus Clock pullup to 3.3V with a 10 kΩ resistor
11	PMBus_Data	Input/Output	PMBus Data pullup to 3.3V with a 10 kΩ resistor
12	DPWM-1A	Output	Digital Pulse Width Modulator output 1A
13	DPWM-1B	Output	Digital Pulse Width Modulator output 1B
14	DPWM-2A	Output	Digital Pulse Width Modulator output 2A
15	SRE-2A	Output	Synchronous rectifier enable 2A, active high
16	DPWM-3A	Output	Digital Pulse Width Modulator output 3A
17	SRE-3A	Output	Synchronous rectifier enable 3A, active high
18	SRE-1B	Output	Synchronous rectifier enable 1B, active high
19	PMBus_Alert	Output	PMBus Alert pullup to 3.3V with a 10 kΩ resistor
20	PMBus_Cntl	Input	PMBus Control pullup to 3.3V with a 10 kΩ resistor
21	GPIO-1	Input/Output	General Purpose Input/Output
22	GPIO-2	Input/Output	General Purpose Input/Output
23	TMUX-0	Input	Temperature multiplexer select S0, V <sub>in</sub> /I <sub>in</sub> Select
24	TMUX-1	Input	Temperature multiplexer select S1
25	FLT-3A	Input	External fault input 3A, active high
26	PowerGood	Input/Output	Power Good Indication
27	(JTAG) TCK	Input	JTAG Test Clock
28	(JTAG) TDO / Sync_Out	Output	JTAG Test data out (muxed with Sync_Out for synchronizing switching frequency across devices)
29	(JTAG) TDI / Sync_In	Input	JTAG Test data in (muxed with Sync_In for synchronizing switching frequency across devices) pull up to 3.3V with a 10 kΩ resistor
30	(JTAG) TMS	Input/Output	JTAG Test mode select - tie to V <sub>33D</sub> with 10 kΩ resistor
31	(JTAG) nTRST	Input/Output	JTAG Test Reset - tie to ground with a 10 kΩ resistor
32	DGND1	Output	Digital Ground
33	V33D	Input	Digital core 3.3V supply
34	V33A	Input	Analog 3.3V supply
35	BPCap	Input	1.8V bypass capacitor connection
36	AGND1	Input	Analog Ground
37	EAP1	Input	Error analog, differential voltage. Positive channel #1 input
38	EAN1	Input	Error analog, differential voltage. Negative channel #1 input
39	EAP2	Input	Error analog, differential voltage. Positive channel #2 input
40	EAN2	Input	Error analog, differential voltage. Negative channel #2 input

**PIN DESCRIPTIONS (continued)**

PIN		I/O	DESCRIPTION
NO.	NAME		
41	V33FB	Output	Connection to the base of 3.3V linear regulator transistor (no connect if unused)
42	CS-1A	Input	Power stage 1A current sense input and input to analog comparator 1
43	ADDR_1	Input	Address sense. Channel 1
44	ADDR_0	Input	Address sense. Channel 0
45	Vtrack	Input	Voltage Track Input
46	Temperature	Input	Temperature Sense input
47	Agnd2	Input	Analog Ground
48	ADCref	Input	ADC Decoupling Capacitor - Tie 0.1 $\mu$ F cap to ground
PowerPad	Power Pad	Input	It is recommended that this pad be connected to analog ground

## FUNCTIONAL OVERVIEW

The UCD9220 contains two fusion power peripherals (FPP). Each FPP can be configured to regulate up to two DC/DC converter outputs. There are four PWM outputs that can be assigned to drive the coverter outputs. Each FPP can be configured to drive from one of the four power stages. Each FPP consists of:

- A differential input error voltage amplifier.
- A 10-bit DAC used to set the output regulation reference voltage.
- A fast ADC with programmable input gain to digitally measure the error voltage.
- A dedicated 3-pole/3-zero digital filter to compensate the error voltage.
- A digital PWM (DPWM) engine that generates the PWM pulse width based on the compensator output.

Each controller is configurable through a PMBus serial interface.

### PMBus Interface

The PMBus is a serial interface specifically designed to support power management. It is based on the SMBus interface that is built on the I<sup>2</sup>C physical specification. The UCD9220 supports revision 1.1 of the PMBus standard. Wherever possible, standard PMBus commands are used to support the function of the device. For unique features of the UCD9220, MFR\_SPECIFIC commands are defined to configure or activate those features. These commands are defined in the [UCD92xx PMBUS Command Reference](#).

The UCD9220 is PMBus compliant, in accordance with the "Compliance" section of the PMBus specification. The firmware is also compliant with the SMBus 1.1 specification, including support for the SMBus ALERT function. The hardware can support 100 kHz, 400 kHz, or 1 MHz PMBus operation.

### Resistor Programmed PMBus Address Decode

Two pins are allocated to decode the PMBus address. At power-up, the device applies a bias current to each address detect pin, and the voltage on that pin is captured by the internal 12-bit ADC. The PMBus address is calculated as follows:

$$\text{PMBus Address} = 12 \times \text{bin}(V_{\text{AD01}}) + \text{bin}(V_{\text{AD00}}) \quad (2) \quad (2)$$

Where  $\text{bin}(V_{\text{AD0x}})$  is the address bin for one of 8 address as shown in [Table 1](#).

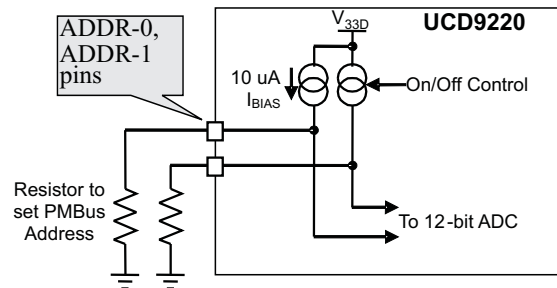

**Figure 4. PMBus Address Detection Method**

The address bins are defined so that each bin is a constant ratio of the previous bin. This method maintains the width of each bin relative to the tolerance of the standard 1% resistors. The ratio between bins is 1.30.

**Table 1. PMBus Address Bins**

PMBus ADDRESS	R <sub>PMBus</sub> PMBus RESISTANCE (kΩ)
open	–
11	210
10	158
9	115
8	84.5

**Table 1. PMBus Address Bins (continued)**

PMBus ADDRESS	$R_{\text{PMBus}}$ PMBus RESISTANCE (k $\Omega$ )
7	63.4
6	47.5
5	36.5
4	27.4
short	–

A low impedance (short) on either address pin that produces a voltage below the minimum voltage causes the PMBus address to default to address 126. A high impedance (open) on either address pin that produces a voltage above the maximum voltage also causes the PMBus address to default to address 126.

The PMBus address can be set to any value ranging from 1 to 126, except address 12. Address 0 is not used because it is the SMBus General Call address; address 12 is reserved for the PMBus alert response. Also, it is recommended that address 11 not be used by this device or any other device that shares the PMBus with it, since it is used in manufacturing to program the device. Further, address 127 cannot be used by this device or any other device that shares the PMBus with it, since the address is reserved by this device for device manufacturing test.

Finally, it is recommended that address 126 not be used for any devices on the PMBus, since this is the address that the UCD9220 defaults to if the address lines are shorted to ground or left open. If any other UCD9220 has a short or open on its address lines, then its address would conflict with the (programmed) address 126.

If a short or open is detected on the PMBus address pin, then the UCD9220 assigns the address to 126 and enables the JTAG port. Note: if the JTAG port is enabled in this way then the JTAG pins are not available for sequencing.

**Table 2. PMBus Address Assignment Rules**

ADDRESS	STATUS	REASON
0	Prohibited	SMBus general address call
1-10	Avaliable	
11	Avoid	Causes confilcts with other devices during program flash updates.
12	Prohibited	PMBus alert response protocol
13-125	Avaliable	
126	Avoid	Default value; may cause conflicts with other devices.
127	Prohibited	Used by TI manufacturing for device tests.

## JTAG Interface

The JTAG interface can provide an alternate interface for programming the device. It is disabled by default in order to enable the sync, and power good status pins with which it is multiplexed. There are three conditions under which the JTAG interface is enabled:

1. When the ROM\_MODE PMBus command is issued.
2. On power-up if the Data Flash is blank. This allows JTAG to be used for writing the configuration parameters to a programmed device with no PMBus interaction.
3. When an invalid address is detected at power-up. By opening or shorting one of the address pins to ground, an invalid address can be generated that enables JTAG.

## Bias Supply Generator (Series Regulator Controller)

Internally, the circuits in the UCD92XX require 3.3V to operate. This can be provided using an existing 3.3V power supply or it can be generated from the power supply input voltage using an internal series regulator and an external transistor. The requirements for the external transistor are that it be an NPN device with a beta of at least 40. [Figure 3](#) shows the typical application using the external series pass transistor. The base of the transistor is driven by a 10k $\Omega$  resistor to  $V_{in}$  and a transconduction amplifier whose output is on the V33FB pin. The NPN emitter becomes the 3.3 V supply for the chip and requires bypass capacitors of 0.1  $\mu$ F and 4.7 $\mu$ F.

A transconductance amplifier sinks current into the V33FB pin, in order to regulate the amount of current allowed into the base of the transistor, which regulates the collector current, which determines the emitter voltage (3.3 V). The resistor value should be sized low enough to give efficient base drive at minimum input voltage, yet large enough to not exceed the maximum current sink capability of the V33FB pin at maximum input voltage. Higher beta transistors help in increasing the minimum resistance value, as less base current is needed to sufficiently drive the higher beta transistor. A resistor value of 10 K $\Omega$  works well for most applications that use the FCX491A BJT.

Some circuits in the device require 1.8V that is generated internally from the 3.3V supply. This voltage requires a 0.1 to 1  $\mu$ F bypass capacitor from BPCap to ground.

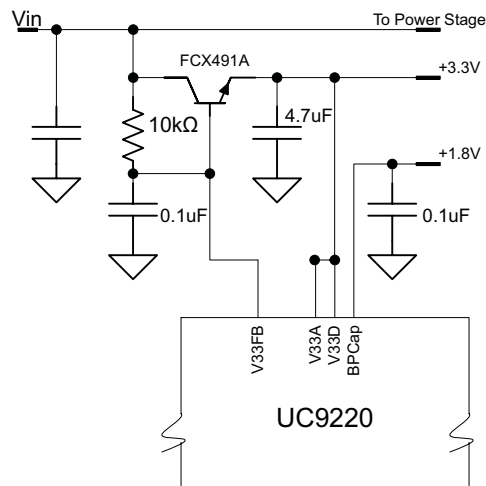

**Figure 5. 3.3V Regulator Circuit**

## Power On Reset

The UCD9220 has an integrated power-on reset (POR) circuit that monitors the supply voltage. At power-up, the POR circuit detects the V33D rise. When V33D is greater than  $V_{IH}$ , the device initiates an internal startup sequence. At the end of the startup sequence, the device begins normal operation, as defined by the downloaded device PMBus configuration.

## External Reset

The device can be forced into the reset state by an external circuit connected to the nRESET pin. A logic low voltage on this pin holds the device in reset. To avoid an erroneous trigger caused by noise, a 10 kΩ pull up resistor to 3.3V is recommended.

## Output Voltage Adjustment

The nominal output voltage is programmed by a combination of PMBus commands: VOUT\_COMMAND, VOUT\_CAL\_OFFSET, and VOUT\_MAX. Their relationship is shown in Figure 6. Output voltage margining is configured by the VOUT\_MARGIN\_HIGH and VOUT\_MARGIN\_LOW commands. The OPERATION command selects between the nominal output voltage and either of the margin voltages. The OPERATION command also includes an option to suppress certain voltage faults and warnings while operating at the margin settings.

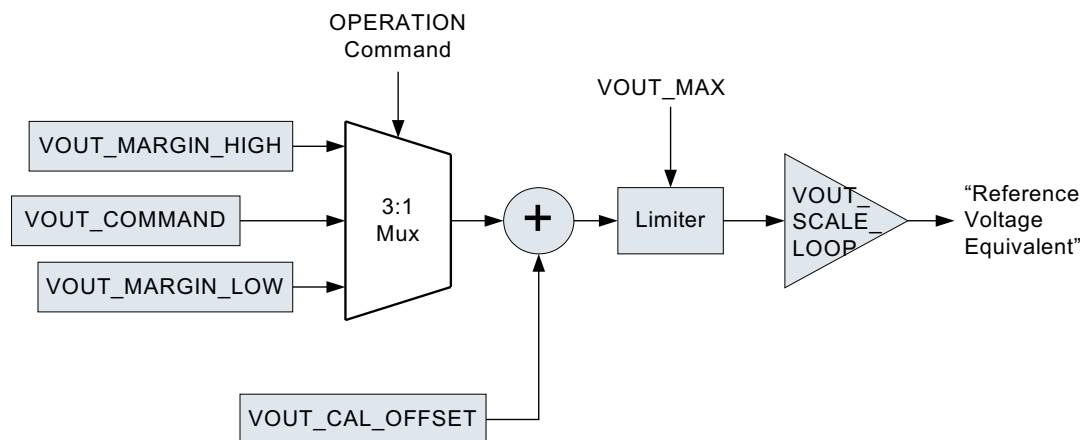

Figure 6. PMBus Voltage Adjustment Methods

For a complete description of the commands supported by the UCD9220 see the [UCD92xx PMBUS Command Reference](#). Each of these commands can also be issued from the Texas Instruments Fusion Digital Power™ Designer program. This Graphical User Interface (GUI) PC program issues the appropriate commands to configure the UCD9220 device.

## Calibration

To optimize the operation of the UCD9220, PMBus commands are supplied to enable fine calibration of output voltage, output current, and temperature measurements. The supported commands and related calibration formulas may be found in the [UCD92xx PMBUS Command Reference](#).

## Analog Front End (AFE)

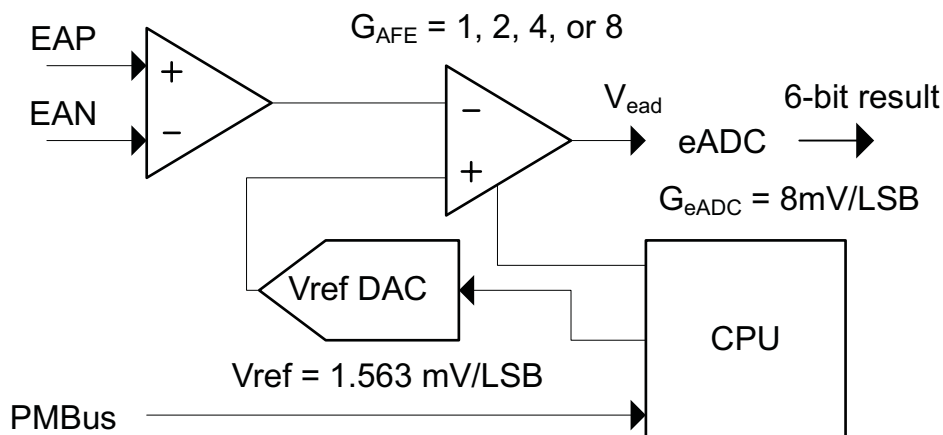

Figure 7. Analog Front End Block Diagram

The UCD9220 senses the power supply output voltage differentially through the EAP and EAN pins. The error amplifier utilizes a switched capacitor topology that provides a wide common mode range for the output voltage sense signals. The fully differential nature of the error amplifier also ensures low offset performance.

The output voltage is sampled at a programmable time (set by the EADC\_SAMPLE\_TRIGGER PMBus command). When the differential input voltage is sampled, the voltage is captured in internal capacitors and then transferred to the error amplifier where the value is subtracted from the set-point reference which is generated by the 10-bit Vref DAC as shown in Figure 7. The resulting error voltage is then amplified by a programmable gain circuit before the error voltage is converted to a digital value by the flash ADC. This programmable gain is configured through the PMBus and affects the dynamic range and resolution of the sensed error voltage as shown in Table 3.

**Table 3. Analog Front End Resolution**

AFE GAIN	AFE_GAIN for PMBus COMMAND	EFFECTIVE ADC RESOLUTION (mV)	DIGITAL ERROR VOLTAGE DYNAMIC RANGE (mV)
1	0	8	-256 to 248
2	1	4	-128 to 124
4	2	2	-64 to 62
8	3	1	-32 to 31

The AFE variable gain is one of the compensation coefficients that are stored when the device is configured by issuing the CLA\_GAINS PMBus command. Compensator coefficients are arranged in several banks: one bank for start/stop ramp or tracking, one bank for normal regulation mode and one bank for light load mode. This allows the user to trade-off resolution and dynamic range for each operational mode.

The EADC, which samples the error voltage, has high accuracy, high resolution, and a fast conversion time. However, its range is limited as shown in Table 3. If the output voltage is different from the reference by more than this, the EADC reports a saturated value at -32 LSBs or 31 LSBs. The UCD9220 overcomes this limitation by adjusting the Vref DAC up or down in order to bring the error voltage out of saturation. In this way, the effective range of the ADC is extended. When the EADC saturates, the Vref DAC is slewed at a rate of 0.156 V/ms, referred to the EA differential inputs.

The differential feedback error voltage  $V_{EA} = V_{EAP} - V_{EAN}$ . For brief instances,  $V_{EA}$  may go as high as the maximum value of  $V_{DIFF}$ ; however, the steady-state commanded voltage must be less than the maximum value of  $V_{ref}$ , which is lower. An attenuator network using resistors R1 and R2 should be used to ensure that  $V_{EA}$  does not exceed the maximum value of  $V_{DIFF}$  when operating at the commanded voltage level.

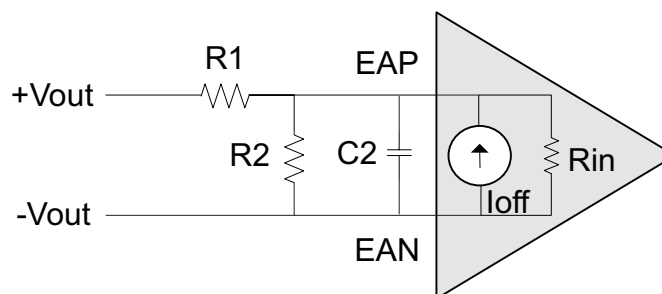

**Figure 8. Input Offset Equivalent Circuit**

To obtain the best possible accuracy, the input resistance and offset current on the device should be considered when calculating the gain of a voltage divider between the output voltage and the EA sense inputs of the UCD9220. The input resistance and input offset current are specified in the parametric tables in this datasheet.  $V_{EA} = V_{EAP} - V_{EAN}$  in the equation below.

$$V_{EA} = \frac{R_2}{R_1 + R_2 + \left(\frac{R_1 R_2}{R_{IN}}\right)} V_{OUT} + \frac{R_1 R_2}{R_1 + R_2 + \left(\frac{R_1 R_2}{R_{IN}}\right)} I_{OFF} \quad (3)$$

The effect of the offset current can be reduced by making the resistance of the divider network low. R1 should be between 1kΩ and 5kΩ. Then R2, the lower divider resistor, can be calculated as:

$$R_2 = \frac{R_1 V_{EA}}{V_{OUT} - \left(1 + \frac{R_1}{R_{IN}}\right) V_{EA} \pm R_1 I_{OFF}} \quad (4)$$

### EAP/EAN Voltage Sense Filtering

Conditioning should be provided on the EAP and EAN signals. [Figure 8](#) shows a divider network between the output voltage and the voltage sense input to the controller. The resistor divider is used to bring the output voltage within the dynamic range of the controller. When no attenuation is needed, R2 can be left open and the signal conditioned by the low-pass filter formed by R1 and C2.

As with any power supply system, maximize the accuracy of the output voltage by sensing the voltage directly across an output capacitor, and route the positive and negative differential sense signals as a balanced pair of traces or as a twisted pair cable back to the controller. Put the divider network close to the controller. This ensures that there is a low impedance driving the differential voltage sense signal from the voltage rail output back to the controller. The resistance of the divider network is a trade-off between power loss and minimizing interference susceptibility. A parallel resistance of 1k to 4kΩ is a good compromise.

$$R_1 = \frac{R_P}{K} \quad R_2 = \frac{R_P}{1-K} \quad \text{where } K = \frac{V_{EA}}{V_{OUT}} \quad \text{and } R_P = \frac{R_1 R_2}{R_1 + R_2} \quad (5)$$

It is recommended that a capacitor be placed across the lower resistor of the divider network. This acts as an additional pole in the compensation and as an anti-alias filter for the EADC. To be effective as an anti-alias filter, the corner frequency should be 35% to 40% of the switching frequency. Then the capacitor is calculated as:

$$C_2 = \frac{1}{2\pi \times 0.35 \times F_{SW} \times R_P} \quad (6)$$

### Digital Compensator

Each voltage rail controller in the UCD9220 includes a digital compensator. The compensator consists of a nonlinear gain stage, followed by a digital filter consisting of a second order infinite impulse response (IIR) filter section cascaded with a first order IIR filter section.

The Texas Instruments Fusion Digital Power™ Designer development tool can be used to assist in defining the compensator coefficients. The design tool allows the compensator to be described in terms of the pole frequencies, zero frequencies and gain desired for the control loop. In addition, the Fusion Digital Power™ Designer can be used to characterize the power stage so that the compensator coefficients can be chosen based on the total loop gain for each feedback system. The coefficients of the filter sections are generated through modeling the power stage and load.

Additionally, the UCD9220 has three banks of filter coefficients: Bank-0 is used during the soft start/stop ramp or tracking; Bank-1 is used while in regulation mode; and Bank-2 is used when the measured output current is below the configured light load threshold.

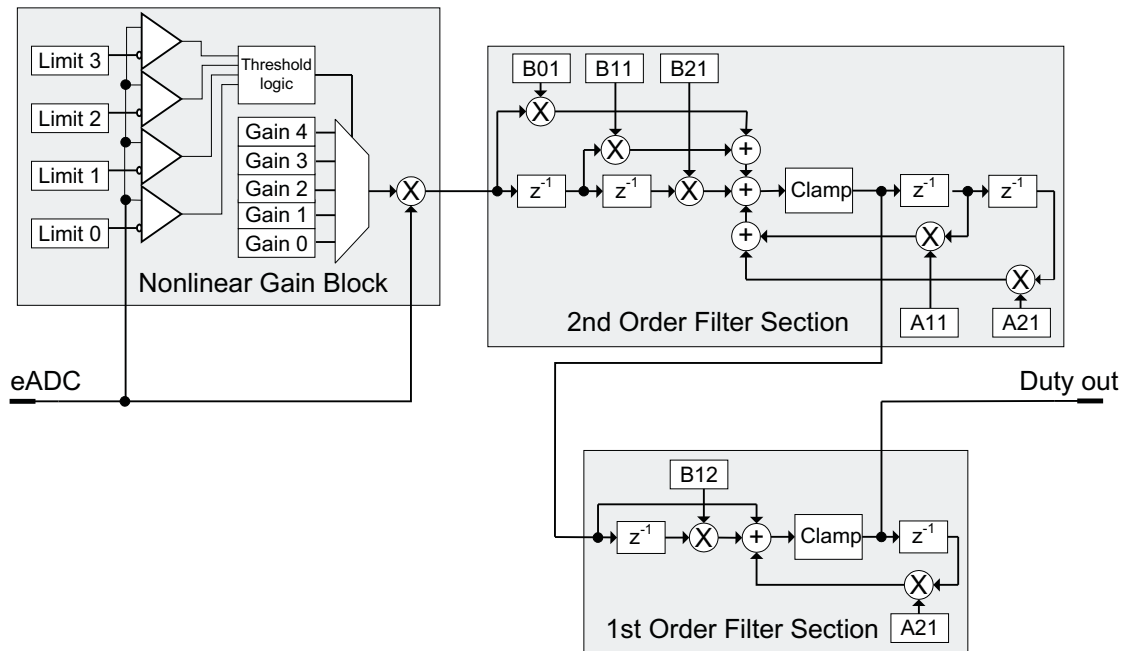

**Figure 9. Digital Compensator**

The nonlinear gain block allows a different gain to be applied to the system when the error voltage deviates from zero. Typically Limit 0 and Limit 1 would be configured with negative values between  $-1$  and  $-32$  and Limit 2 and Limit 3 would be configured with positive values between  $1$  and  $31$ . However, the gain thresholds do not have to be symmetrical. For example, the four limit registers could all be set to positive values causing the Gain 0 value to set the gain for all negative errors and a nonlinear gain profile would be applied to only positive error voltages.

The cascaded 1st order filter section is used to generate the third zero and third pole.

## DPWM Engine

The output of the compensator feeds the high resolution DPWM engine. The DPWM engine produces the pulse width modulated gate drive output from the device. In operation, the compensator calculates the necessary duty cycle as a digital number representing a percentage from 0 to 100%. The duty cycle value is multiplied by the configured period to generate a comparator threshold value. This threshold is compared against the high speed switching period counter to generate the desired DPWM pulse width. This is shown in [Figure 10](#).

Each DPWM engine can be synchronized to another DPWM engine or to an external sync signal via the SYNC\_IN and SYNC\_OUT pins. Configuration of the synchronization function is done through a MFR\_SPECIFIC PMBus command. See the DPWM Synchronization section for more details.

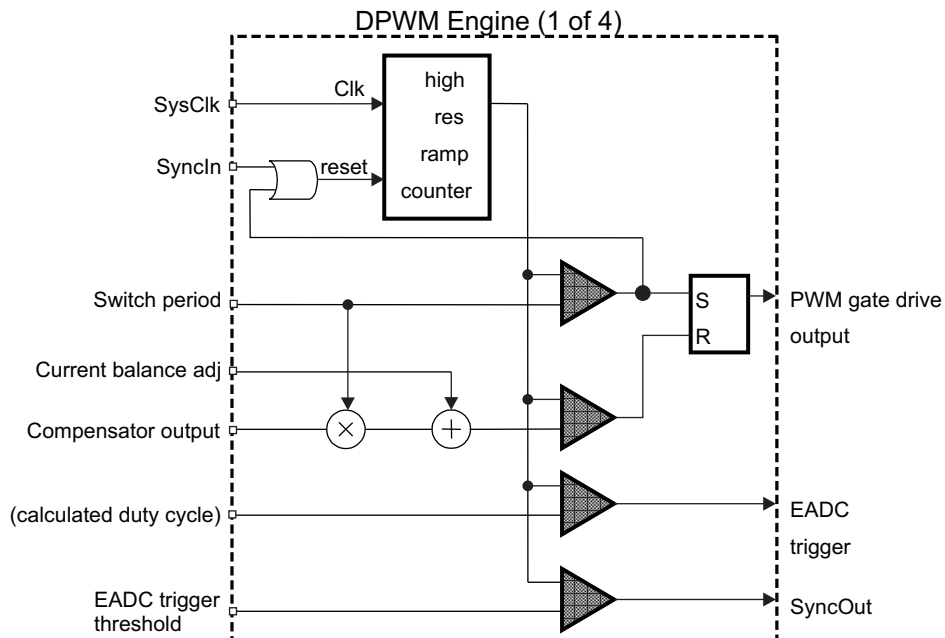

Figure 10. DPWM Engine

### Flexible Rail/Power Stage Configuration

The UCD9220 can control one to two voltage rails, each of which can comprise a programmable number of power stages (up to a maximum of four). The following table shows all possible rail / power stage configurations. Configuration is made through the PHASE\_INFO command which is described in detail in the [UCD92xx PMBus Command Reference](#).

Table 4. Power Stage Configurations<sup>(1)</sup>

NUMBER OF STAGES RAIL #1 : RAIL #2	RAIL #1 POWER STAGES	RAIL #2 POWER STAGES
4 : 0	1A, 1B, 2A, 3A	(none)
3 : 0	1A, 1B, 2A	(none)
2 : 0	1A, 1B	(none)
1 : 0	1A	(none)
3 : 1	1A, 1B, 3A	2A
2 : 1	1A, 1B	2A
1 : 1	1A	2A
2 : 2	1A, 1B	2A, 3A
1 : 2	1A	2A, 3A
1 : 3	Invalid (use 3 : 1 instead)	
0 : 4	Invalid (use 4 : 0 instead)	
0 : 3	Invalid (use 3 : 0 instead)	
0 : 2	Invalid (use 2 : 0 instead)	
0 : 1	Invalid (use 1 : 0 instead)	

(1) Phases should be selected in the order listed. For a two single phase rail configuration, power stage selections should be 1A and 2A.

## DPWM Phase Distribution

When two rails are configured, the UCD9220 offsets (in time) the phase of the 1st power stage assigned to each rail in order to minimize input current ripple. The constant time used for this offset is:

$$t_{\text{rail-rail spread}} = \frac{3}{13} t_{\text{SW}} \quad (7)$$

Where  $t_{\text{SW}}$  is the period of the rail with the fastest switching frequency.

The ratio 3/13 is chosen because it is close to 1/4, but it is a prime ratio. This should ensure that any configuration of rails and power stages should not have the leading edge of the DPWM signal aligned.

The PHASE\_INFO PMBus command is also used to configure the number of power stages driving each voltage rail. When multiple power stages are configured to drive a voltage rail, the UCD9220 automatically distributes the phase of each DPWM output to minimize ripple. This is accomplished by setting the rising edge of each DPWM pulse to be separated by:

$$t_{\text{phase-phase spread}} = \frac{t_{\text{SW}}}{N_{\text{Phases}}} \quad (8)$$

Where  $t_{\text{SW}}$  is the switching period and  $N_{\text{Phases}}$  is the number of power stages driving a voltage rail.

## DPWM Synchronization

DPWM synchronization provides a method to link the timing between rails on two distinct devices at the switching rate; i.e., two rails on different devices can be configured to run at the same frequency and sync forcing them not to drift from each other. (Note that within a single device, because all rails are driven off a common clock there is no need for an internal sync because rails will not drift.)

The PMBus SYNC\_IN\_OUT command sets which rails (if any) should follow the sync input, and which rail (if any) should drive the sync output.

For rails that are following the sync input, the DPWM ramp timer for that output is reset when the sync input goes high. This allows the slave device to sync to inputs that are either faster or slower than it is. On the fast side, there is no limit to how much faster the input is compared to the defined frequency of the rail; when the pulse comes in, the timer is reset and the frequencies are locked. This is the standard mode of operation - setting the slave to run slower, and letting the sync speed it up.

If the slave rail is running fast, the sync pulse resets the counter after the DPWM output has already been turned on. Resetting the counter at this point results in a larger duty cycle for that period. Because the system is closed loop; however, the controller reacts by decreasing the commanded control effort, with the result being a regulated rail synchronized to a slower master. Synchronizing to the slower master does have a limit however. If the master is slow enough that the DPWM output has sufficient time to output the entire command pulse before the sync input arrives, the result is a double pulse. This is likely an undesirable mode of operation.

The Sync Input and Output Configuration Word set by the PMBus command consists of two bytes. The upper byte (sync\_out) controls which rail drives the sync output signal (0=DWPM1, 1=DPWM2, 2=DPWM3, 3=DPWM4. Any other value disables sync\_out). The lower byte (sync\_in) determines which rail(s) respond to the sync input signal (each bit represents one rail - note that multiple rails can be synchronized to the input). The DPWM period is aligned to the sync input. For more information, see the [UCD92xx PMBUS Command Reference](#).

Note that once a rail is synchronized to an external source, the rail-to-rail spacing that attempts to minimize input current ripple are lost. Rail-to-rail spacing can only be restored by power cycling or issuing a SOFT\_RESET command.

## Phase Shedding at Light Current Load

By issuing LIGHT\_LOAD\_LIMIT\_LOW, LIGHT\_LOAD\_LIMIT\_HIGH, and LIGHT\_LOAD\_CONFIG commands, the UCD9220 can be configured to shed (disable) power stages when at light load. When this feature is enabled, the device disables the configured number of power stages when the average current drops below the specified LIGHT\_LOAD\_LIMIT\_LOW. In addition, a separate set of compensation coefficients can be loaded into the digital compensator when entering a light load condition.

## Phase Adding at Normal Current Load

After shedding phases, if the current load is increased past the LIGHT\_LOAD\_LIMIT\_HIGH threshold, all phases are re-enabled. If the compensator was configured for light load, the normal load coefficients are restored as well. See the [UCD92xx PMBUS Command Reference](#) for more information.

## Current Sense Input Filtering

Each power stage current is monitored by the device at the CS pins. There are 3 "A" channel pins and 1 "B" channel pin. The B channels monitors the current with a 12-bit ADC and samples each current sense voltage in turn. The A channels monitor the current with the same 12-bit ADC and also monitor the current with a digitally programmable analog comparator.

Because the current sense signal is digitally sampled, it should be conditioned with an RC network acting as an anti-alias filter. Since the sample rate for the CS inputs is  $1/t_{\text{out}}$ , a good cutoff frequency for the RC network is from 2 kHz to 3 kHz.

## Output Current Measurement

Pins CS-1A, CS-1B, CS-2A, and CS-3A are used to measure either output current or inductor current in each of the controlled power stages. PMBus commands IOUT\_CAL\_GAIN and IOUT\_CAL\_OFFSET are used to calibrate each measurement. See the [UCD92xx PMBus Command Reference](#) for specifics on configuring this voltage to current conversion.

When the measured current is outside the range of either the over-current or under-current fault threshold, a current fault is declared and the UCD9220 performs the PMBus configured fault recovery. ADC current measurements are digitally averaged before they are compared against the current fault threshold. The output current is measured at a rate of one output rail per  $t_{\text{out}}$  microseconds. The current measurements are then passed through a digital smoothing filter to reduce noise on the signal and prevent false errors. The output of the smoothing filter asymptotically approaches the input value with a time constant that is approximately 3.5 times the sampling interval.

**Table 5. Output Current Filter Times Constants**

NUMBER OF OUTPUT RAILS	OUTPUT CURRENT SAMPLING INTERVALS ( $\mu\text{s}$ )	FILTER TIME CONSTANTS (ms)
1	200	0.7
2	400	1.4
3	600	2.1
4	800	2.8

For example, with a single rail, the filter has the transfer function characteristics ([Figure 11](#)) that shows the signal magnitude at the output of the averaging filter due to a sine wave input for a range of frequencies. This plot includes an RC analog low pass network, with a corner frequency of 3 kHz, on the current sense inputs.

This averaged current measurement is used for output current fault detection; see [Over-current Detection](#) below.

In response to a PMBus request for a current reading, the device returns an average current value. When the UCD9220 is configured to drive a multi-phase power converter, the device adds the average current measurement for each of the power stages tied to a power rail.

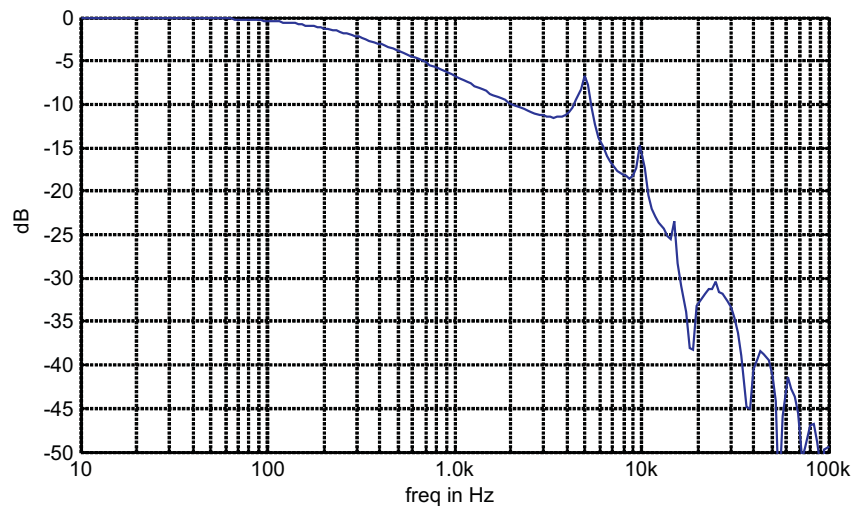

**Figure 11. Averaging Filter for Current Monitoring**

## Output Current Balancing

When the UCD9220 is configured to drive multiple power stage circuits from one compensator, current balancing is implemented by adjusting each gate drive output pulse width to correct for current imbalance between the connected power stage sections. The UCD9220 balances the current by monitoring the current at the CS analog input for each power stage and then adding a current balance adjustment value to the DPWM ramp threshold value for each power stage.

When there is more than one power stage connected to the voltage rail, the device continually determines which stage has the highest measured current and which stage has the lowest measured current. To balance the currents while maintaining a constant total current, the adjustment value for the power stage with the lowest current is increased by the same amount as the adjustment value for the power stage with the highest current is decreased. A slight modification to this algorithm is made to keep the adjustment values positive in order to ensure that a positive DPWM duty cycle is commanded under all conditions.

## Over-Current Detection

Several mechanisms are provided to sense output current fault conditions. This allows for the design of power systems with multiple layers of protection.

1. An integrated gate driver such as the UCD7230 can be used to generate the FLT signal. The UCD7230 monitors the voltage drop across the high side FET and if it exceeds a resistor/voltage programmed threshold, the UCD7230 activates its fault output. The FLT input can be disabled by reconfiguring the FLT pin to be a sequencing pin in the GUI. A logic high signal on the FLT input causes a hardware interrupt to the internal CPU. The CPU then determines which DPWM outputs are configured to be associated with the voltage rail that contained the fault and disables those DPWM and SRE outputs. This process takes about 14 microseconds.
2. Inputs CS-1A, CS-1B, CS-2A and CS-3A each drive an internal analog comparator. These comparators can be used to detect the voltage output of a current sense circuit. Each comparator has a separate PMBus configurable threshold. This threshold is set by issuing the FAST\_OC\_FAULT\_LIMIT command. Though the command is specified in amperes, the hardware threshold is programmed with a value between 31mV and 2V in 64 steps. The relationship between the amperes to sensed volts is configured using the IOUT\_CAL\_GAIN command. When the current sense voltage exceeds the configured threshold the corresponding DPWM and SRE outputs are driven low on the voltage rail with the fault.

3. Each Current Sense input to the UCD9220 is also monitored by the 12-bit ADC. Each measured value is scaled using the IOUT\_CAL\_GAIN and IOUT\_CAL\_OFFSET commands. The currents for each power stage configured as part of a voltage rail are summed and compared to the OC limit set by the IOUT\_OC\_FAULT\_LIMIT command. The action taken when a fault is detected is defined by the IOUT\_OC\_FAULT\_RESPONSE command.

Because the current measurement is averaged with a smoothing filter, the response time to an Over-current condition depends on a combination of the time constant ( $\tau$ ) from [Table 5](#), the recent measurement history, and how much the measured value exceeds the over-current limit. When the current steps from a current ( $I_1$ ) that is less than the limit to a higher current ( $I_2$ ) that is greater than the limit, the output of the smoothing filter is:

$$I_{\text{smoothed}}(t) = I_1 + (I_2 - I_1) \left( 1 - e^{-\frac{t}{\tau}} \right) \quad (9)$$

At the point when  $I_{\text{smoothed}}$  exceeds the limit, the smoothing filter lags time,  $t_{\text{lag}}$  is:

$$t_{\text{lag}} = \tau \ln \left( \frac{I_2 - I_1}{I_2 - I_{\text{limit}}} \right) \quad (10)$$

The worst case response time to an over-current condition is the sum of the sampling interval (see [Table 5](#)) and the smoothing filter lag,  $t_{\text{lag}}$  from the equation above.

### Current Foldback Mode

When the measured output current exceeds the value specified by the IOUT\_OC\_FAULT\_LIMIT command, the UCD9220 attempts to continue to operate by reducing the output voltage in order to maintain the output current at the value set by IOUT\_OC\_FAULT\_LIMIT. This continues indefinitely as long as the output voltage remains above the minimum value specified by IOUT\_OC\_LV\_FAULT\_LIMIT. If the output voltage is pulled down to less than that value, the device responds as programmed by the IOUT\_OC\_LV\_FAULT\_RESPONSE command.

### Input Voltage and Current Monitoring

The Vin/Iin pin on the UCD9220 monitors the input voltage and current. To measure both input voltage and input current, an external multiplexer is required, see [Figure 3](#). If measurement of only the input voltage, and not input current, is desired, then a multiplexer is not needed. The multiplexer is switched between voltage and current using the TMUX-0 signal. (This signal is the LSB of the temperature mux select signals, so the TMUX-0 signal is connected both to the temperature multiplexer as well as the voltage/current multiplexer). When TMUX-0 is low, the Vin/Iin pin will be sampled for Vin. When TMUX-0 is high, the Vin/Iin pin will be sampled for Iin. The Vin/Iin pin is monitored using the internal 12-bit ADC which has a dynamic range of 0 to 2.5V. The fault thresholds for the input voltage are set using the VIN\_OV\_FAULT\_LIMIT and VIN\_UV\_FAULT\_LIMIT commands. The scaling for Vin is set using the VIN\_SCALE\_MONITOR command, and the scaling for Iin is set using the IIN\_SCALE\_MONITOR command.

### Temperature Monitoring

Both the internal device temperature and up to four external temperatures are monitored by the UCD9220. The controller supports multiple PMBus commands related to temperature, including READ\_TEMPERATURE\_1, which reads the internal temperature, READ\_TEMPERATURE\_2, which reads the external power stage temperatures, OT\_FAULT\_LIMIT, which sets the over temperature fault limit, and OT\_FAULT\_RESPONSE, which defines the action to take when the configured limit is exceeded.

If more than one external temperature is to be measured, the UCD9220 provides analog multiplexer select pins (TMUX0-1) to allow up to 4 external temperatures to be measured. The output of the multiplexer is routed to the Temperature pin. The controller cycles through each of the power stage temperature measurement signals. The signal from the external temperature sensor is expected to be a linear voltage proportional to temperature. The PMBus commands TEMPERATURE\_CAL\_GAIN and TEMPERATURE\_CAL\_OFFSET are used to scale the measured temperature-dependent voltage to °C.

The inputs to the multiplexer are mapped in the order that the outputs are assigned in the PHASE\_INFO PMBus command. For example, if only one power stage is wired to each DPWM, the two temperature signals should be wired to the first two multiplexer inputs.

The UCD9220 monitors temperature using the 12-bit monitor ADC, sampling each temperature in turn with a 800 ms sample period. These measurements are smoothed by a digital filter, similar to that used to smooth the output current measurements. The filter has a time constant 15.5 times the sample interval, or 12.4 s ( $15.5 \times 800$  ms = 12.4 seconds). This filtering reduces the probability of false fault detections.

Figure 3 is an example of a system with two output voltage rails where each output is driven by 2 power stages. The first output voltage rail is driven with DPWM-1A and DPWM-1B. The second output voltage rail is driven with DPWM-2A and DPWM-3A. The order in which the temperature multiplexer inputs are assigned is shown in Table 6.

**Table 6. Temperature Sensor Mapping**

TEMPERATURE MUX INPUT	POWER STAGE
1Y0	DPWM-1A
1Y1	DPWM-1B
1Y2	DPWM-2A
1Y3	DPWM-3A

### Temperature Balancing

Temperature balancing between phases is performed by adjusting the current such that cooler phases draw a larger share of the current. Temperature balancing occurs slowly (the loop runs at a 10 Hz rate), and only when the phase currents exceeds the PMBus settable TEMP\_BALANCE\_IMIN. This minimum current threshold prevents the controller from "winding up" and forcing one phase to carry all the current under a low-load condition, when the total current may be insufficient to significantly affect phase temperatures.

### Soft Start, Soft Stop Ramp Sequence

The UCD9220 performs soft start and soft stop ramps under closed loop control. Performing a start or stop ramp or tracking is considered a separate operational mode. The other operational modes are normal regulation and light load regulation. Each operational mode can be configured to have an independent loop gain and compensation. Each set of loop gain coefficients is called a "bank" and is configured using the CLA\_GAINS PMBus command.

Start ramps are performed by waiting for the configured start delay TON\_DELAY and then ramping the internal reference toward the commanded reference voltage at the rate specified by the TON\_RISE time and VOUT\_COMMAND. The DPWM and SRE outputs are enabled when the internal ramp reference equals the preexisting voltage (pre-bias) on the output and the calculated DPWM pulse width exceeds the pulse width specified by DRIVER\_MIN\_PULSE. This ensures that a constant ramp rate is maintained, and that the ramp is completed at the same time it would be if there were not a pre-bias condition.

The behavior of soft-stop ramps depends on how the voltage rail is configured. If PAGE\_ISOLATED is set to 1 through the PAGE\_ISOLATED PMBus command, the controller assumes that it is the only device driving the voltage rail, and the soft-stop ramp is performed with SRE enabled until the voltage associated with the configured minimum supported pulse width is reached. If PAGE\_ISOLATED is set to 0, the controller assumes that multiple power stages may be supplying the voltage rail and SRE is disabled at the beginning of the soft-stop ramp. Figure 12 shows the operation of soft-start ramps and soft-stop ramps.

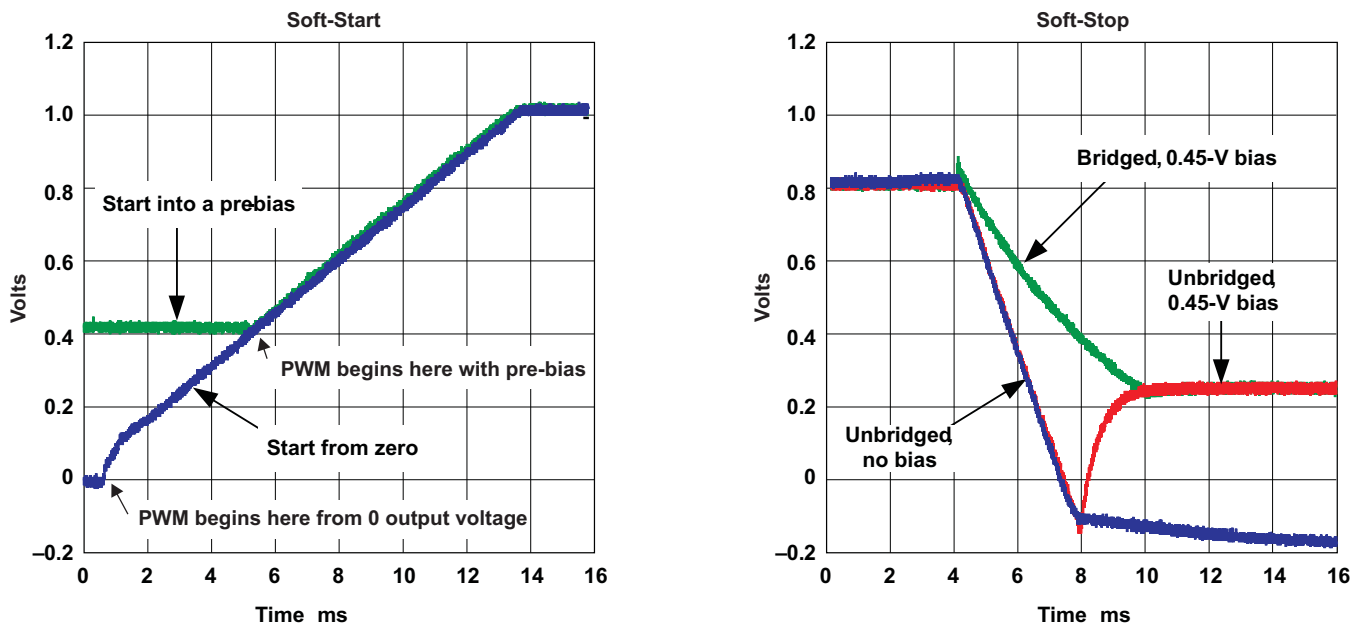

Figure 12. Start and Stop Ramps

When a voltage rail is in its idle state, the DPWM and SRE outputs are disabled, and the differential voltage on the EAP/EAN pins are monitored by the controller. During idle the Vref DAC is adjusted to minimize the error voltage. If there is a pre-bias (that is, a non-zero voltage on the regulated output), then the device can begin the start ramp from that voltage with a minimum of disturbance. This is done by calculating the duty cycle that is required to match the measured voltage on the rail. Nominally this is calculated as  $V_{out} / V_{in}$ ; however, to allow for losses and offsets in the system, PREBIAS\_GAIN and PREBIAS\_OFFSET can be used for fine tuning. If the pre-bias voltage on the output requires a smaller pulse width than the driver can deliver, as defined by the DRIVER\_MIN\_PULSE PMBus command, then the start ramp is delayed until the internal ramp reference voltage has increased to the point where the required duty cycle exceeds the specified minimum duty.

Once a soft start/stop ramp has begun, the output is controlled by adjusting the Vref DAC at a fixed rate and allowing the digital compensator control engine to generate a duty cycle based on the error. The Vref DAC adjustments are made at a rate of 10 kHz and are based on the TON\_RISE or TOFF\_FALL PMBus configuration parameters.

Although the presence of a pre-bias voltage or a specified minimum DPWM pulse width affects the time when the DPWM and SRE signals become active, the time from when the controller starts processing the turn-on command to the time when it reaches regulation is TON\_DELAY plus TON\_RISE, regardless of the pre-bias or minimum duty cycle.

During a normal ramp (i.e. no tracking, no current limiting events and no EADC saturation), the Vref slews at a pre-calculated rate based on the commanded output voltage and TON\_RISE. Under closed loop control, the compensator follows this ramp up to the regulation point.

Because the EADC in the controller has a limited range, it may saturate due to a large transient during a start/stop ramp. If this occurs, the controller overrides the calculated Vref ramp value, and adjusts the Vref DAC in the direction to minimize the error. It continues to step the Vref DAC in this direction until the EADC comes out of saturation. Once it is out of saturation, the start ramp continues, but from this new Vref voltage; and therefore, has an impact on the ramp time.

### Input Under-Voltage Lockout

The UCD9220 monitors the input voltage through the  $V_{in}/I_{in}$  pin and adjusts this value by VIN\_SCALE. The input supply voltage lock-out thresholds are configured with the VIN\_ON and VIN\_OFF commands. When input supply voltage drops below the value set by VIN\_OFF, the device starts a normal soft stop ramp. When the input supply voltage drops below the voltage set by VIN\_UV\_FAULT\_LIMIT, the device performs per the configuration using the VIN\_UV\_FAULT\_RESPONSE command. For example, when the bias supply for the controller is derived

from another source, the response code can be set to "Continue" or "Continue with delay," and the controller attempts to finish the soft stop ramp. If the bias voltages for the controller and gate driver are uncertain below some voltage, the user can set the UV fault limit to that voltage and specify the response code to be "shut down immediately" disabling all DPWM and SRE outputs. VIN\_OFF sets the voltage at which the output voltage soft-stop ramp is initiated, and VIN\_UV\_FAULT\_LIMIT sets the voltage where power conversion is stopped.

## Voltage Tracking

Each voltage rail can be configured to operate in a tracking mode. When a voltage rail is configured to track another voltage rail, it adjusts the Vref to follow the master, which can be either the other internal rail or the external Vtrack pin. As in standard non-tracking mode, a target Vout is still specified for the voltage rail. If the tracking input exceeds this target, the tracking voltage rail stops following the master signal, switches to regulation gains, and regulates at the target voltage. When the tracking input drops back below the target (with 20 mV of hysteresis), tracking gains are re-loaded, and the voltage rail follows the tracking reference. Note that the target can be set above the range of the tracking input, forcing the voltage rail to always remain in tracking mode.

During tracking, the setpoint DAC is permitted to change only as fast as is possible without inducing the EADC to saturate. This limit may be reached if the master ramps at an extremely fast rate, or if the master is at a significantly different voltage when the rail is turned on. As in normal regulation, a current limit (current foldback) or the detection of the EADC saturating forces the rail to temporarily deviate from the tracking reference.

The PMBus command TRACKING\_SOURCE is available to enable tracking mode and select the master to track. The tracking mode is set individually for each rail, allowing each rail to have a different master, both rails to share a master, or one rail to track while the other remains independent. Additionally, TRACKING\_SCALE\_MONITOR permits tracking a voltage with a fixed ratio to a master voltage. For example, a ratio of 0.5 causes the rail to regulate at one half of the master's voltage.

## Sequencing

There are three methods to sequence voltage rails controlled by the UCD9220 that allow for a variety of system sequencing configurations. Each of these options is configurable in the GUI. These methods include:

1. Use the PMBus to set the soft start/stop parameters for each rail. Multiple start/stop sequences may be triggered simultaneously. Each voltage rail performs its sequencing in an open-loop manner. If any rail fails to complete its sequence, all other rails are unaffected.
2. Daisy-chain the PowerGood output signal from one controller to the PMBus-CNTL input on another.
3. Use the GPIO\_SEQ\_CONFIG command to assign dependencies between rails, or to configure unused pins as sequencing control inputs or sequencing status outputs.

**Method 1:** Each rail has programmable delay times, TON\_DELAY and TOFF\_DELAY, before beginning a soft start ramp or a soft stop ramp, and programmable ramp times, TON\_RISE and TOFF\_FALL determine how long the ramp takes. These PMBus commands are defined in the [UCD92xx PMBUS Command Reference](#). The parameters can also be configured using the Fusion Digital Power™ Designer GUI (see [http://focus.ti.com/docs/toolsw/folders/print/fusion\\_digital\\_power\\_designer.html](http://focus.ti.com/docs/toolsw/folders/print/fusion_digital_power_designer.html)). The configurable times can be used to program a time based sequence for each voltage rail. Using this method each rail ramps independently and completes the ramp regardless of the success of the other rails.

The start/stop sequence is initiated for a single rail by the PMBus-CNTL pin or via the PMBus using the OPERATION or ON\_OFF\_CONTROL commands.

The start/stop sequence may be initiated simultaneously for multiple rails within the same controller by configuring each rail to respond to the PMBus-CNTL pin. Alternatively, after setting the PMBus PAGE variable to 255, subsequent OPERATION or ON\_OFF\_CONTROL commands applies to all rails at the same time.

To simultaneously initiate start/stop sequences in multiple controllers, a common PMBus-CNTL signal can be fed into each controller. Alternatively, the PMBus Group Command Protocol may be used to send separate commands to multiple controllers. All the commands are sent in one continuous transmission and wait for the final STOP signal in order to start executing their commands simultaneously.

**Method 2:** The PowerGood pin can be used to coordinate multiple controllers by running the PowerGood pin output from one controller to the PMBus-CNTL input pin of another. This imposes a master/slave relationship between multiple devices. During startup, the slave controllers initiates their start sequences after the master completes its start sequence and reaches its regulation voltage. During shut-down, as soon as the master starts its shut-down sequence, the shut-down signals to its slaves.

Unlike Method 1, a shut-down on one or more rails on the master can initiate shut-downs of the slave devices. The master shut-downs can initiate intentionally or by a fault condition.

The PMBus specification implies that the PowerGood signal is active when ALL the rails in a controller are above their power-good “on” threshold setting. The UCD9220 allows the PowerGood pin to be reprogrammed using the GPIO\_SEQ\_CONFIG command so that the pin responds to a desired subset of rails.

This method works to coordinate multiple controllers, but it does not enforce interdependency between rails within a single controller.

**Method 3:** Using the GPIO\_SEQ\_CONFIG command, several sequencing options can be configured using undedicated pins for input/output. As many as four pins can be configured as inputs, and as many as eight as outputs. The outputs can be open-drain or actively driven with selectable polarity.

Each rail can be configured to respond to a combination of the power-good status of other internal rails and/or the state of sequencing input pins. The output pins can be configured to reflect the power-good status of a combination of rails, or to one of several status indicators including power-good, an Overcurrent warning, or the “open-drain outputs valid” signal.

When using the output signals for sequencing, they may be routed to sequencing control inputs or to the PMBus-CNTL inputs on other controllers.

Once each rail’s input dependencies are configured, the rail responds to those input pins or internal rails. Like method 2, shut-downs on one rail or controller can initiate shut-downs of other rails or controllers. Unlike method 2, GPIO\_SEQ\_CONFIG offers much more flexibility in assigning relationships between multiple rails within a single controller or between multiple controllers. It is possible for each controller to be both a master and a slave to another controller.

GPIO\_SEQ\_CONFIG allows the configuration of fault relationships such that a fault on one rail can result in the shut down of any selection of rails in addition to the rail at fault. These fault interactions are not constrained to a single master/slave relationship; for example, a system can be configured such that a fault on any rail shuts down all rails. If the fault response of the failing rail is to shut down immediately, all dependent rails follow suit and shuts down immediately regardless of their programmed response code.

Each rail can be optionally configured to monitor a sequencing input pin for a specified period of time after it turns on and reaches its power good threshold. If the programmable timeout is reached before the input pin state matches its defined logic level, the rail is shut down, and a status error posted. This feature could be used, for example, to ensure that an LDO on the board did turn on when the main system voltage came up. Each rail is enabled independently of the other rails and has a unique timeout value; a single input pin is used as the timeout source.

The setup of the GPIO\_SEQ\_CONFIG command is aided by the use of the Fusion Digital Power™ Designer, which graphically displays relationships between rails and provides intuitive controls to allocate and configure available resources.

The following pins are available for use as GPIO or sequencing control, provided they are not being used for their primary purpose:

PIN NAME	48-PIN
DPWM-1A	IN/OUT
DPWM-1B	IN/OUT
DPWM-2A	IN/OUT
DPWM-3A	IN/OUT
FAULT-1A	IN/OUT
FAULT-2A	IN/OUT
FAULT-3A	IN/OUT
FAULT-4A	IN/OUT
SRE-1A	IN/OUT
SRE-1B	IN/OUT
SRE-2A	IN/OUT
SRE-3A	IN/OUT
PowerGood	IN/OUT
GPIO_1	IN/OUT
GPIO_2	IN/OUT

### Non-volatile Memory Error Correction Coding

The UCD9220 uses Error Correcting Code (ECC) to improve data integrity and provide high reliability storage of Data Flash contents. ECC uses dedicated hardware to generate extra check bits for the user data as it is written into the Flash memory. This adds an additional six bits to each 32-bit memory word stored into the Flash array. These extra check bits, along with the hardware ECC algorithm, allow for any single bit error to be detected and corrected when the Data Flash is read.

### ADCref Pin

ACDref pin is the decoupling pin of the ADC12. Connect this pin to ground through a 0.1 $\mu$ F – 1 $\mu$ F capacitor.

### General Purpose I/O Pin

The UCD9220 has 2 general purpose I/O pins that can be use for sequencing. For more information about sequencing see the [sequencing section](#) above and the GPIO\_SEQ\_CONFIG command in the [UDC92xx PMBus Command Reference](#).

## APPLICATION INFORMATION

### Calculation of Open Loop Gain Using the UCD9220

When designing a power supply it is necessary to determine the stability of the closed loop system. The usual way to do this is to determine the open loop gain versus frequency and from the open loop gain determine the gain margin and phase margin. Figure 13 shows a block diagram of a complete control loop using the UCD9220. Each component of the loop gain that is a function of frequency is labeled "Gx". Constant gain components are labeled "Kx".

CONSTANT GAIN COMPONENTS	DESCRIPTION
$G_{plant}$	Transfer function for the power stage circuit consisting of the FET switches, LC output filter and load.
$G_{div}$	Transfer function for the VOUT sense divider and its capacitive filter network.
$K_{AFE}$	Analog front-end amplifier gain.
$K_{EADC}$	Gain of the 6-bit EADC in units of LSBs/V
$G_{delay}$	Phase shift due to the delays in the control loop.
$K_{nonlinear}$	Nonlinear function gain. Gain for the limit interval that contains zero error.
$G_{CLA2}$	Transfer function of the second order filter section of the compensator.
$G_{CLA1}$	Transfer function of the first order filter section of the compensator.
$K_{PWM}$	Accounts for the bit resolution of the input to the DPWM

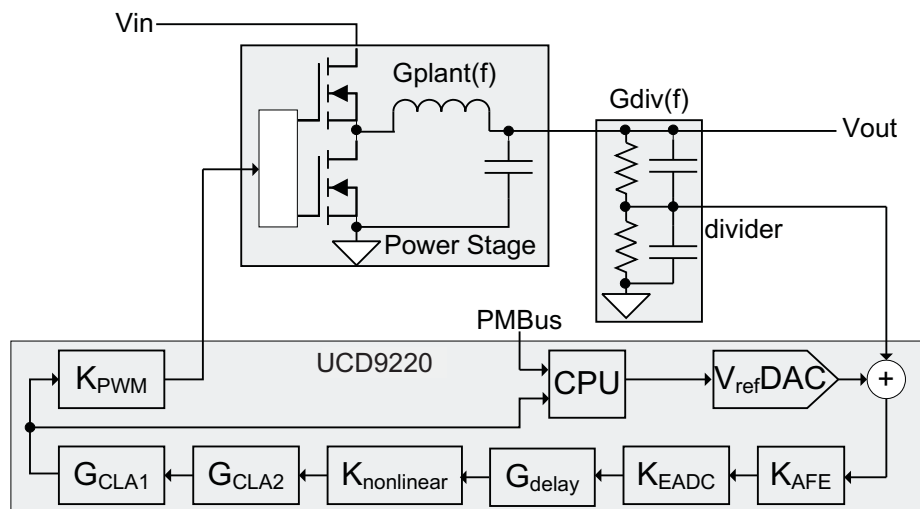

Figure 13. Loop Gain Contributions

Several of the gain blocks are programmable. They are configured by issuing a CLA\_GAINS command over the PMBus. The syntax for this command is shown in the [UCD92xx PMBUS Command Reference](#). These gains can also be configured using the Fusion Digital Power™ Designer PC program.

### Automatic System Identification ( Auto-ID™)

By using digital circuits to create the control function for a switch-mode power supply, additional features can be implemented. One of those features is the measurement of the open loop gain and stability margin of the power supply without the use of external test equipment. This capability is called automatic system identification or Auto-ID™. To identify the frequency response, the UCD9220 internally synthesizes a sine wave signal and injects it into the loop at the set point DAC. This signal excites the system, and the closed-loop response to that excitation can be measured at another point in the loop. The UCD9220 measures the response to the excitation at the output of the digital compensator. From the closed-loop response, the open-loop transfer function is calculated. The open-loop transfer function may be calculated from the closed-loop response.

Note that since the compensator and DPWM are digital, their transfer functions are known exactly and can be divided out of the measured open-loop gain. In this way the UCD9220 can accurately measure the power stage/load plant transfer function in situ (in place), on the factory floor or in an end equipment application and send the measurement data back to a host through the PMBus interface without the need for external test equipment. Details of the Auto-ID™ PMBus measurement commands can be found in the [UCD92xx PMBus Command Reference](#).

### Output Voltage Margining

The UCD9220 supports Voltage Margining using the PMBus VOUT\_MARGIN\_HIGH and VOUT\_MARGIN\_LOW commands in conjunction with the OPERATION command. The margin voltages can be configured at device configuration and saved into Data Flash. The output can be commanded to switch between Margin High, Nominal, and Margin Low using bits [3:2] of the OPERATION command.

### Data Logging

The UCD9220 maintains a data log in non-volatile memory. This log tracks the peak internal and external temperature measurements, peak current measurements, and fault history. The PMBus commands and data format for data logging can be found in the [UCD92xx PMBUS Command Reference](#).

**PACKAGING INFORMATION**

Orderable Device	Status (1)	Package Type	Package Drawing	Pins	Package Qty	Eco Plan (2)	Lead/Ball Finish (6)	MSL Peak Temp (3)	Op Temp (°C)	Device Marking (4/5)	Samples
UCD9220RGZR	ACTIVE	VQFN	RGZ	48	2500	Green (RoHS & no Sb/Br)	NIPDAU	Level-3-260C-168 HR	-40 to 125	UCD9220	<a href="#">Samples</a>
UCD9220RGZT	ACTIVE	VQFN	RGZ	48	250	Green (RoHS & no Sb/Br)	NIPDAU	Level-3-260C-168 HR	-40 to 110	UCD9220	<a href="#">Samples</a>

(1) The marketing status values are defined as follows:

**ACTIVE:** Product device recommended for new designs.

**LIFEBUY:** TI has announced that the device will be discontinued, and a lifetime-buy period is in effect.

**NRND:** Not recommended for new designs. Device is in production to support existing customers, but TI does not recommend using this part in a new design.

**PREVIEW:** Device has been announced but is not in production. Samples may or may not be available.

**OBSOLETE:** TI has discontinued the production of the device.

(2) **RoHS:** TI defines "RoHS" to mean semiconductor products that are compliant with the current EU RoHS requirements for all 10 RoHS substances, including the requirement that RoHS substance do not exceed 0.1% by weight in homogeneous materials. Where designed to be soldered at high temperatures, "RoHS" products are suitable for use in specified lead-free processes. TI may reference these types of products as "Pb-Free".

**RoHS Exempt:** TI defines "RoHS Exempt" to mean products that contain lead but are compliant with EU RoHS pursuant to a specific EU RoHS exemption.

**Green:** TI defines "Green" to mean the content of Chlorine (Cl) and Bromine (Br) based flame retardants meet JS709B low halogen requirements of <=1000ppm threshold. Antimony trioxide based flame retardants must also meet the <=1000ppm threshold requirement.

(3) MSL, Peak Temp. - The Moisture Sensitivity Level rating according to the JEDEC industry standard classifications, and peak solder temperature.

(4) There may be additional marking, which relates to the logo, the lot trace code information, or the environmental category on the device.

(5) Multiple Device Markings will be inside parentheses. Only one Device Marking contained in parentheses and separated by a "~" will appear on a device. If a line is indented then it is a continuation of the previous line and the two combined represent the entire Device Marking for that device.

(6) Lead/Ball Finish - Orderable Devices may have multiple material finish options. Finish options are separated by a vertical ruled line. Lead/Ball Finish values may wrap to two lines if the finish value exceeds the maximum column width.

**Important Information and Disclaimer:** The information provided on this page represents TI's knowledge and belief as of the date that it is provided. TI bases its knowledge and belief on information provided by third parties, and makes no representation or warranty as to the accuracy of such information. Efforts are underway to better integrate information from third parties. TI has taken and continues to take reasonable steps to provide representative and accurate information but may not have conducted destructive testing or chemical analysis on incoming materials and chemicals. TI and TI suppliers consider certain information to be proprietary, and thus CAS numbers and other limited information may not be available for release.

In no event shall TI's liability arising out of such information exceed the total purchase price of the TI part(s) at issue in this document sold by TI to Customer on an annual basis.



**TAPE AND REEL INFORMATION**

**QUADRANT ASSIGNMENTS FOR PIN 1 ORIENTATION IN TAPE**

\*All dimensions are nominal

Device	Package Type	Package Drawing	Pins	SPQ	Reel Diameter (mm)	Reel Width W1 (mm)	A0 (mm)	B0 (mm)	K0 (mm)	P1 (mm)	W (mm)	Pin1 Quadrant
UCD9220RGZR	VQFN	RGZ	48	2500	330.0	16.4	7.3	7.3	1.5	12.0	16.0	Q2
UCD9220RGZR	VQFN	RGZ	48	2500	330.0	16.4	7.3	7.3	1.1	12.0	16.0	Q2
UCD9220RGZT	VQFN	RGZ	48	250	180.0	16.4	7.3	7.3	1.5	12.0	16.0	Q2
UCD9220RGZT	VQFN	RGZ	48	250	180.0	16.4	7.3	7.3	1.1	12.0	16.0	Q2

**TAPE AND REEL BOX DIMENSIONS**

\*All dimensions are nominal

Device	Package Type	Package Drawing	Pins	SPQ	Length (mm)	Width (mm)	Height (mm)
UCD9220RGZR	VQFN	RGZ	48	2500	367.0	367.0	38.0
UCD9220RGZR	VQFN	RGZ	48	2500	367.0	367.0	38.0
UCD9220RGZT	VQFN	RGZ	48	250	210.0	185.0	35.0
UCD9220RGZT	VQFN	RGZ	48	250	210.0	185.0	35.0

## GENERIC PACKAGE VIEW

**RGZ 48**

**VQFN - 1 mm max height**

7 x 7, 0.5 mm pitch

PLASTIC QUADFLAT PACK- NO LEAD

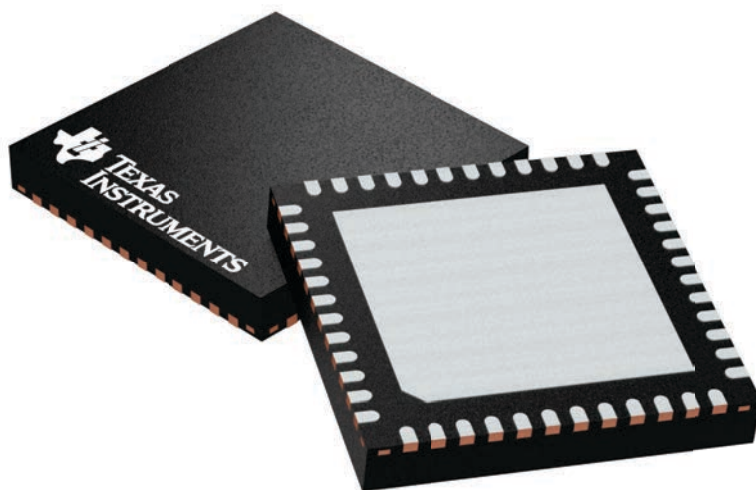

Images above are just a representation of the package family, actual package may vary.  
Refer to the product data sheet for package details.

4224671/A

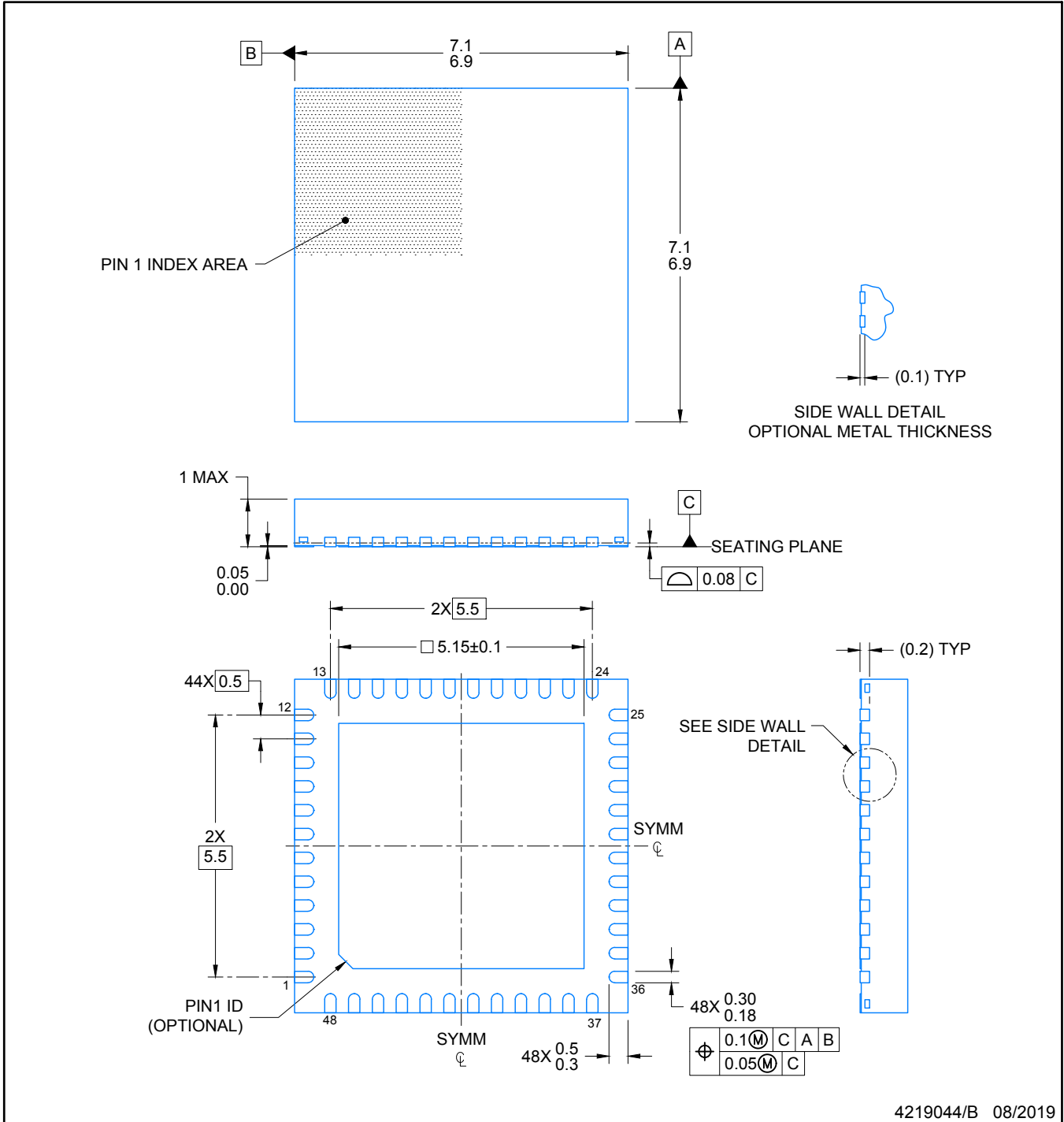

NOTES:

1. All linear dimensions are in millimeters. Any dimensions in parenthesis are for reference only. Dimensioning and tolerancing per ASME Y14.5M.
2. This drawing is subject to change without notice.
3. The package thermal pad must be soldered to the printed circuit board for optimal thermal and mechanical performance.

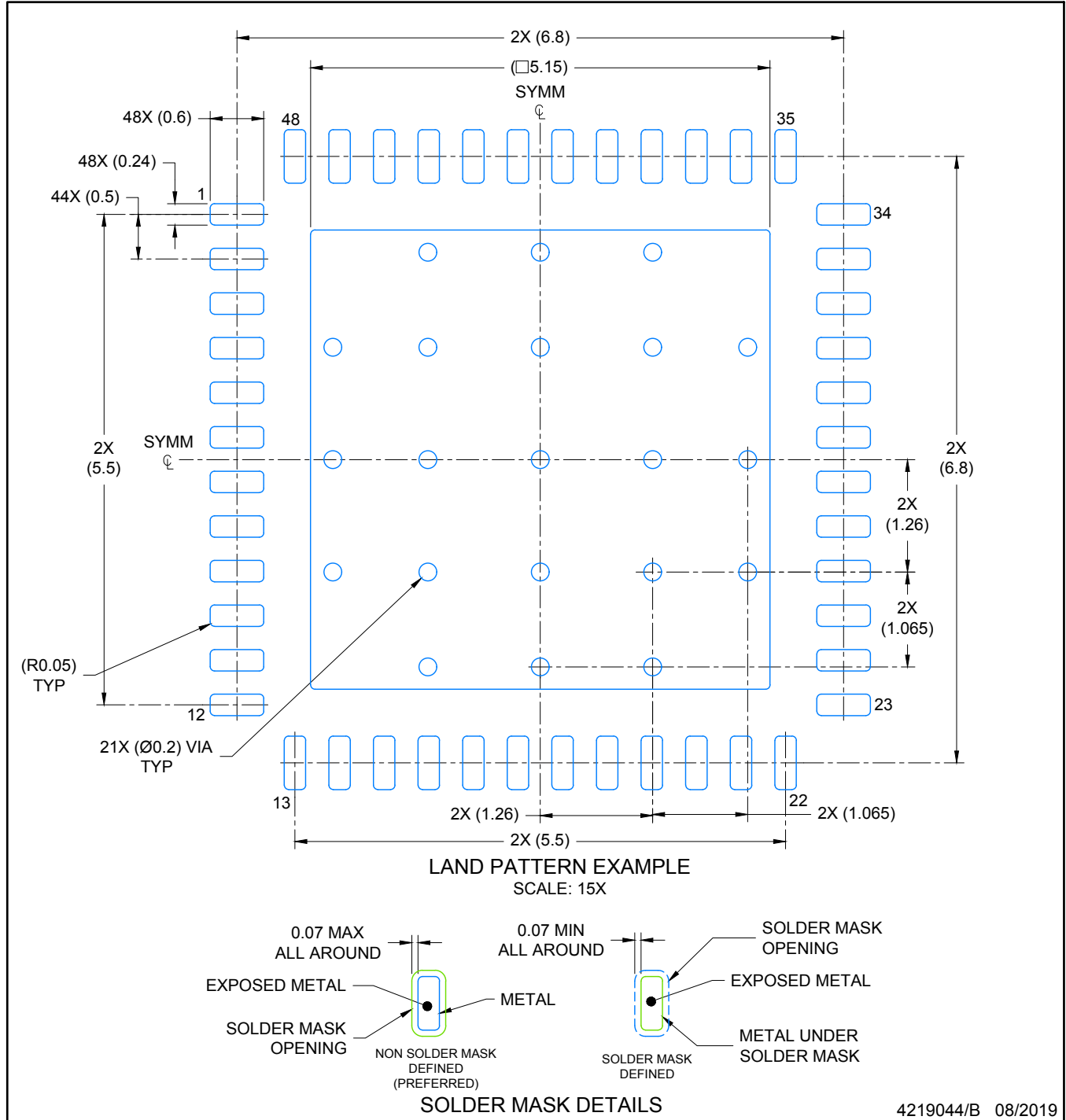

NOTES: (continued)

4. This package is designed to be soldered to a thermal pad on the board. For more information, see Texas Instruments literature number SLUA271 ([www.ti.com/lit/slua271](http://www.ti.com/lit/slua271)).
5. Vias are optional depending on application, refer to device data sheet. If any vias are implemented, refer to their locations shown on this view. It is recommended that vias under paste be filled, plugged or tented.

# EXAMPLE STENCIL DESIGN

RGZ0048A

VQFN - 1 mm max height

PLASTIC QUADFLAT PACK- NO LEAD

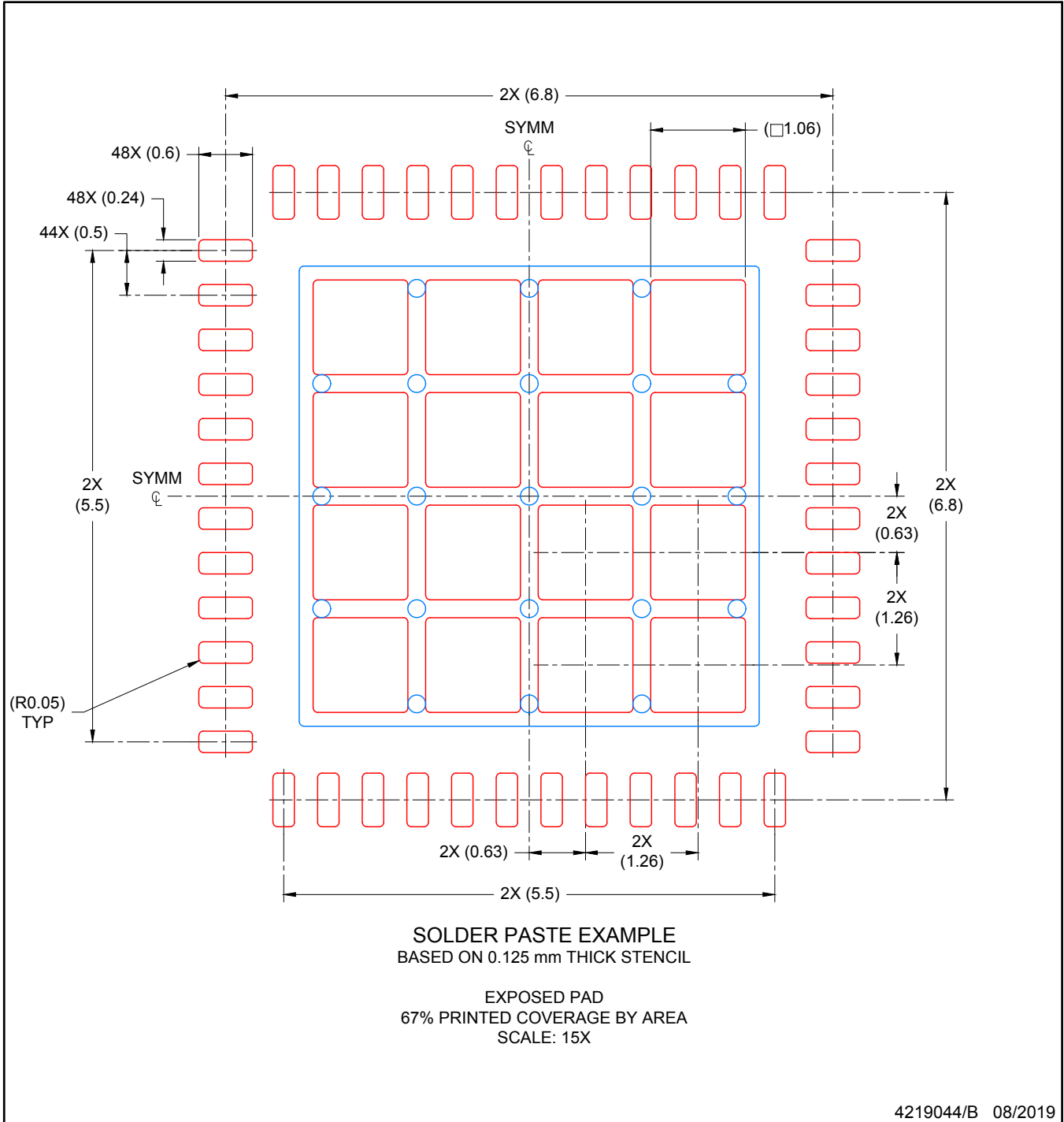

NOTES: (continued)

6. Laser cutting apertures with trapezoidal walls and rounded corners may offer better paste release. IPC-7525 may have alternate design recommendations.

## IMPORTANT NOTICE AND DISCLAIMER

TI PROVIDES TECHNICAL AND RELIABILITY DATA (INCLUDING DATASHEETS), DESIGN RESOURCES (INCLUDING REFERENCE DESIGNS), APPLICATION OR OTHER DESIGN ADVICE, WEB TOOLS, SAFETY INFORMATION, AND OTHER RESOURCES "AS IS" AND WITH ALL FAULTS, AND DISCLAIMS ALL WARRANTIES, EXPRESS AND IMPLIED, INCLUDING WITHOUT LIMITATION ANY IMPLIED WARRANTIES OF MERCHANTABILITY, FITNESS FOR A PARTICULAR PURPOSE OR NON-INFRINGEMENT OF THIRD PARTY INTELLECTUAL PROPERTY RIGHTS.

These resources are intended for skilled developers designing with TI products. You are solely responsible for (1) selecting the appropriate TI products for your application, (2) designing, validating and testing your application, and (3) ensuring your application meets applicable standards, and any other safety, security, or other requirements. These resources are subject to change without notice. TI grants you permission to use these resources only for development of an application that uses the TI products described in the resource. Other reproduction and display of these resources is prohibited. No license is granted to any other TI intellectual property right or to any third party intellectual property right. TI disclaims responsibility for, and you will fully indemnify TI and its representatives against, any claims, damages, costs, losses, and liabilities arising out of your use of these resources.

TI's products are provided subject to TI's Terms of Sale ([www.ti.com/legal/termsofsale.html](http://www.ti.com/legal/termsofsale.html)) or other applicable terms available either on [ti.com](http://ti.com) or provided in conjunction with such TI products. TI's provision of these resources does not expand or otherwise alter TI's applicable warranties or warranty disclaimers for TI products.

Mailing Address: Texas Instruments, Post Office Box 655303, Dallas, Texas 75265  
Copyright © 2020, Texas Instruments Incorporated