

## 4.5-V to 18-V Input, 1.5-A Step-Down Regulator with Integrated Switcher

Check for Samples: [TPS53511](#)

### FEATURES

- Continuous 1.5-A Output Current
- 4.5-V to 18-V Supply Voltage Range
- 2-V to 18-V Conversion Voltage Range
- DCAP2™ Mode Control Enables Fast Transient Response
- Low Output Ripple and Support all MLCC Output Capacitor
- Skip Mode for Light Load Control
- Highly Efficient Integrated FETs Optimized for Lower Duty Cycle Applications
- High Efficiency, Less than 10- $\mu$ A Supply Current at Shutdown
- Adjustable Soft-Start Time
- Support Pre-Biased Soft Start
- 700-kHz Switching Frequency
- Cycle-By-Cycle Overcurrent Limit
- Open Drain Power Good Indication
- Internal Bootstrap Switch
- Small 3 mm x 3 mm, 16-Pin QFN (RGT) Package

### APPLICATIONS

- Points-of-Load for Server
- Distributed Non-Isolated DC-DC Converters for Computing Power System

### DESCRIPTION

The TPS53511 is an adaptive on-time D-CAP2™ mode synchronous buck converter. The device is suitable for points-of-load (POL) in computing power systems, and provides a cost-effective, low component count, low standby current solution. The main control loop for the TPS53511 uses the D-CAP2™ mode control providing a fast transient response with no external components. The adaptive on-time control supports seamless operation between PWM mode during heavy load conditions and reduced frequency operation during light load conditions for high efficiency.

The TPS53511 includes a proprietary circuit that enables the device to adapt to both low equivalent series resistance (ESR) output capacitors, such as POSCAP or SP-CAP, and ultra-low ESR ceramic capacitors. The device operates from 4.5-V to 18-V supply input, and from 2-V to 18-V input power supply voltage. The device features an adjustable slow start time and a power good function. It also supports pre-biased soft start. The TPS53511 is available in the 16-pin QFN package, and designed to operate from  $-40^{\circ}\text{C}$  to  $85^{\circ}\text{C}$ .

### TYPICAL APPLICATION

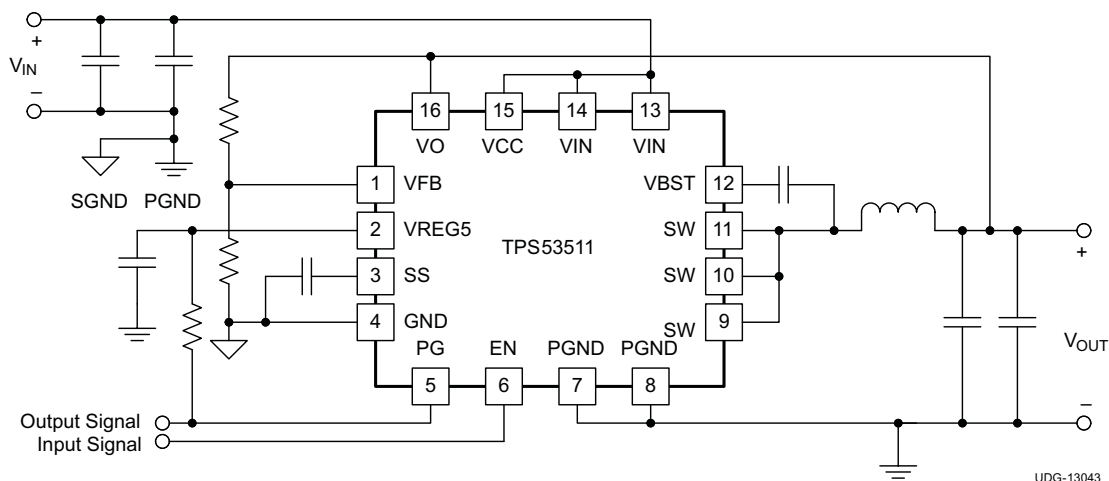

Please be aware that an important notice concerning availability, standard warranty, and use in critical applications of Texas Instruments semiconductor products and disclaimers thereto appears at the end of this data sheet.

DCAP2, PowerPAD are trademarks of Texas Instruments.



This integrated circuit can be damaged by ESD. Texas Instruments recommends that all integrated circuits be handled with appropriate precautions. Failure to observe proper handling and installation procedures can cause damage.

ESD damage can range from subtle performance degradation to complete device failure. Precision integrated circuits may be more susceptible to damage because very small parametric changes could cause the device not to meet its published specifications.

### ORDERING INFORMATION

T <sub>A</sub>	PACKAGE	ORDERING DEVICE NUMBER	PINS	OUTPUT SUPPLY	MINIMUM QUANTITY	ECO PLAN
–40°C to 85°C	Plastic QFN (RGT)	TPS53511RGTR	16	Tape and reel	3000	Green (RoHS and no Pb/Br)
		TPS53511RGTT		Mini reel	250	

### ABSOLUTE MAXIMUM RATINGS<sup>(1)(2)</sup>

over operating free-air temperature range (unless otherwise noted)

		MIN	MAX	UNIT
Input voltage range	VIN, VCC, EN	–0.3	20	V
	VBST	–0.3	26	
	VBST(with respect to SW)	–0.3	6.5	
	SS, VO, VFB	–0.3	6.5	
	SW	dc	–2	
		transient < 10 ns	–3	20
Voltage differential	GND to PowerPAD	–0.2	0.2	V
Output voltage range	PG, VREG5	–0.3	6.5	V
	PGND	–0.3	0.3	
Output current	I <sub>OUT</sub>		1.5	A
Electrostatic Discharge	Human Body Model (HBM)		2000	V
	Charged Device Model (CDM)		500	
Storage junction temperature		–55	150	°C
Operating junction temperature		–40	150	°C

- (1) Stresses beyond those listed under “absolute maximum ratings” may cause permanent damage to the device. These are stress ratings only and functional operation of the device at these or any other conditions beyond those indicated under “recommended operating conditions” is not implied. Exposure to absolute-maximum-rated conditions for extended periods may affect device reliability.
- (2) All voltages are with respect to GND. Currents are positive into and negative out of the specified terminal.

**RECOMMENDED OPERATING CONDITIONS**

		MIN	TYP	MAX	UNIT
Input voltage range	VIN	2.0		18.0	V
	VCC	4.5		18.0	
	EN	-0.1		18.0	
	VBST	-0.1		24.0	
	VBST(with respect to SW)	-0.1		5.7	
	VO, VFB, SS	-0.1		5.5	
	SW	dc	-1.8		
	transient , <10 ns	-3		18	
Output voltage range	PG, VREG5	-0.1		5.7	V
	PGND	-0.1		0.1	
Junction temperature range, T <sub>J</sub>		-40		125	°C
Operating free-air temperature, T <sub>A</sub>		-40		85	°C

**THERMAL INFORMATION**

THERMAL METRIC <sup>(1)</sup>		TPS53511	UNITS
		QFN (RGT)	
		16 PINS	
$\theta_{JA}$	Junction-to-ambient thermal resistance <sup>(2)</sup>	45.3	°C/W
$\theta_{JcTop}$	Junction-to-case (top) thermal resistance <sup>(3)</sup>	57.3	
$\theta_{JB}$	Junction-to-board thermal resistance <sup>(4)</sup>	18.4	
$\psi_{JT}$	Junction-to-top characterization parameter <sup>(5)</sup>	1.1	
$\psi_{JB}$	Junction-to-board characterization parameter <sup>(6)</sup>	18.4	
$\theta_{JcBot}$	Junction-to-case (bottom) thermal resistance <sup>(7)</sup>	3.9	

- (1) For more information about traditional and new thermal metrics, see the *IC Package Thermal Metrics* application report, [SPRA953](#).
- (2) The junction-to-ambient thermal resistance under natural convection is obtained in a simulation on a JEDEC-standard, high-K board, as specified in JESD51-7, in an environment described in JESD51-2a.
- (3) The junction-to-case (top) thermal resistance is obtained by simulating a cold plate test on the package top. No specific JEDEC-standard test exists, but a close description can be found in the ANSI SEMI standard G30-88.
- (4) The junction-to-board thermal resistance is obtained by simulating in an environment with a ring cold plate fixture to control the PCB temperature, as described in JESD51-8.
- (5) The junction-to-top characterization parameter,  $\psi_{JT}$ , estimates the junction temperature of a device in a real system and is extracted from the simulation data for obtaining  $\theta_{JA}$ , using a procedure described in JESD51-2a (sections 6 and 7).
- (6) The junction-to-board characterization parameter,  $\psi_{JB}$ , estimates the junction temperature of a device in a real system and is extracted from the simulation data for obtaining  $\theta_{JA}$ , using a procedure described in JESD51-2a (sections 6 and 7).
- (7) The junction-to-case (bottom) thermal resistance is obtained by simulating a cold plate test on the exposed (power) pad. No specific JEDEC standard test exists, but a close description can be found in the ANSI SEMI standard G30-88.

## ELECTRICAL CHARACTERISTICS

over recommended free-air temperature range,  $V_{VIN} = 12\text{ V}$ ,  $PGND = GND$  (unless otherwise noted).<sup>(1)</sup>

PARAMETER		TEST CONDITIONS	MIN	TYP	MAX	UNIT
<b>SUPPLY CURRENT</b>						
$I_{VCC}$	Operating, non-switching supply current	$T_A = 25^\circ\text{C}$ , $V_{EN} = 5\text{ V}$ , $V_{VFB} = 0.8\text{ V}$		850	1300	$\mu\text{A}$
$I_{VCC(sdn)}$	Shutdown supply current	$T_A = 25^\circ\text{C}$ , $V_{EN} = 0\text{ V}$		1.8	10	$\mu\text{A}$
<b>LOGIC THRESHOLD</b>						
$V_{ENH}$	EN high-level input voltage		2			V
$V_{ENL}$	EN low-level input voltage				0.4	V
<b><math>V_{VFB}</math> VOLTAGE AND DISCHARGE RESISTANCE</b>						
$V_{VFB}$	Voltage light load mode	$T_A = 25^\circ\text{C}$ , $V_{OUT} = 1.05\text{ V}$ , $I_{OUT} = 10\text{ mA}$		771		mV
	Threshold voltage, continuous mode	$T_A = 25^\circ\text{C}$ , $V_{OUT} = 1.05\text{ V}$	757	765	773	mV
		$T_A = 0^\circ\text{C}$ to $85^\circ\text{C}$ , $V_{OUT} = 1.05\text{ V}$ <sup>(2)</sup>	753		777	
		$T_A = -40^\circ\text{C}$ to $85^\circ\text{C}$ , $V_{OUT} = 1.05\text{ V}$ <sup>(2)</sup>	751		779	
$I_{VFB}$	Input current	$V_{FB} = 0.8\text{ V}$ , $T_A = 25^\circ\text{C}$	-0.1	0	0.1	$\mu\text{A}$
$R_{Dischg}$	$V_O$ discharge resistance	$V_{EN} = 0\text{ V}$ , $V_{OUT} = 0.5\text{ V}$ , $T_A = 25^\circ\text{C}$		50	100	$\Omega$
<b><math>V_{VREG5}</math> OUTPUT</b>						
$V_{VREG5}$	Output voltage	$T_A = 25^\circ\text{C}$ , $6\text{ V} < V_{VCC} < 18\text{ V}$ , $0 < I_{VREG5} < 5\text{ mA}$	5.3	5.5	5.7	V
$V_{LN5}$	Line regulation	$6\text{ V} < V_{VCC} < 18\text{ V}$ , $I_{VREG5} = 5\text{ mA}$			20	mV
$V_{LD5}$	Load regulation	$0 < I_{VREG5} < 5\text{ mA}$			100	mV
$I_{VREG5}$	Output current	$V_{CC} = 6\text{ V}$ , $V_{VREG5} = 4\text{ V}$ , $T_A = 25^\circ\text{C}$		70		mA
<b>MOSFET</b>						
$R_{DS(on)H}$	High-side switch resistance	$T_A = 25^\circ\text{C}$ , $(V_{BST} - V_{SW}) = 5.5\text{ V}$		120		m $\Omega$
$R_{DS(on)L}$	Low-side switch resistance	$T_A = 25^\circ\text{C}$		70		m $\Omega$
<b>CURRENT LIMIT</b>						
$I_{OCL}$	Current limit	$L_{OUT} = 1.5\text{ }\mu\text{H}$ <sup>(2)</sup>	1.65	2.00	2.75	A
<b>THERMAL SHUTDOWN</b>						
$T_{SDN}$	Thermal shutdown threshold	Shutdown temperature <sup>(2)</sup>		150		$^\circ\text{C}$
		Hysteresis <sup>(2)</sup>		25		

(1) See PS pin description for levels.

(2) Specified by design. Not production tested.

**ELECTRICAL CHARACTERISTICS (continued)**

 over recommended free-air temperature range,  $V_{VIN} = 12\text{ V}$ ,  $PGND = GND$  (unless otherwise noted).<sup>0</sup>

PARAMETER		TEST CONDITIONS	MIN	TYP	MAX	UNIT
<b>ON-TIME TIMER CONTROL</b>						
$t_{ON}$	On time	$V_{VIN} = 12\text{ V}$ , $V_{OUT} = 1.05\text{ V}$		145		ns
$t_{OFF(min)}$	Minimum off time	$T_A = 25^\circ\text{C}$ , $V_{VFB} = 0.7\text{ V}$		260	310	ns
<b>SOFT-START FUNCTION</b>						
$I_{SSC}$	Soft-start charge current	$V_{SS} = 0\text{ V}$	1.4	2.0	2.6	$\mu\text{A}$
$I_{SSD}$	Soft-start discharge current	$V_{SS} = 0.5\text{ V}$	0.1	0.2		mA
<b>POWER GOOD</b>						
$V_{THPG(UV)}$	Power good undervoltage threshold	$V_{VFB}$ rising (good)	85%	90%	95%	
		$V_{VFB}$ falling (fault)		85%		
$V_{THPG(OV)}$	Power good overvoltage threshold	$V_{VFB}$ rising (fault)	110%	115%	120%	
		$V_{VFB}$ falling (good)		110%		
$I_{PG}$	Sink current	$V_{PG} = 0.5\text{ V}$	2.5	5.0		mA
<b>OUTPUT UNDERVOLTAGE AND OVERVOLTAGE PROTECTION</b>						
$V_{OVP}$	Output OVP trip threshold	OVP detect	110%	115%	120%	
$t_{OVPDEL}$	Output OVP propagation delay			5		$\mu\text{s}$
$V_{UVP}$	Output UVP trip threshold	UVP detect	65%	70%	75%	
		Hysteresis		10%		
$t_{UVPDEL}$	Output UVP delay			0.25		ms
$t_{UVPEN}$	Output UVP enable delay	Relative to soft-start time		$t_{SS} \times 1.7$		
<b>UNDERVOLTAGE LOCKOUT</b>						
UVLO	Wake-up $V_{REG5}$ voltage threshold		3.55	3.80	4.05	V
	Hysteresis $V_{REG5}$ voltage threshold		0.23	0.35	0.47	

**DEVICE INFORMATION**

**PIN FUNCTIONS**

PIN		I/O/P	DESCRIPTION
NAME	NO.		
EN	6	I	Enable control input
GND	4	–	Signal ground pin
PG	5	O	Open drain power good output
PGND	7	P	Ground returns for low-side MOSFET. Also serves as inputs of current comparators. Connect PGND and GND strongly together near the device.
	8		
SS	3	I/O	Soft-start control. An external capacitor should be connected to GND.
SW	9	I/O	Switch node connection between high-side N-channel FET and low-side N-channel FET. Also serves as inputs to current comparator.
	10		
	11		
VBST	12	I	Supply input for high-side N-channel FET gate driver (boost terminal). Connect capacitor from this pin to respective SW terminals. An internal PN diode is connected between VREG5 to VBST pin.
VCC	15	I	Supply input for 5V internal linear regulator for the control circuitry
VFB	1	I	Converter feedback input. Connect with feedback resistor divider.
VIN	13	I	Power input and connected to high side N-channel FET drain
	14		
VO	16	I	Connect to output of converter. This terminal is used for on-time adjustment.
VREG5	2	O	5.5-V power supply output. A capacitor (typical 1- $\mu$ F) should be connected to GND.
PowerPAD		–	Thermal pad of the package. Must be soldered to achieve appropriate dissipation. Should be connected to PGND.

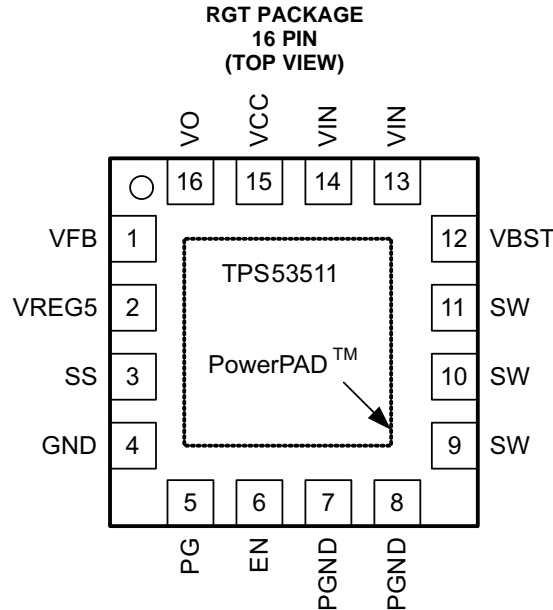

FUNCTIONAL BLOCK DIAGRAM

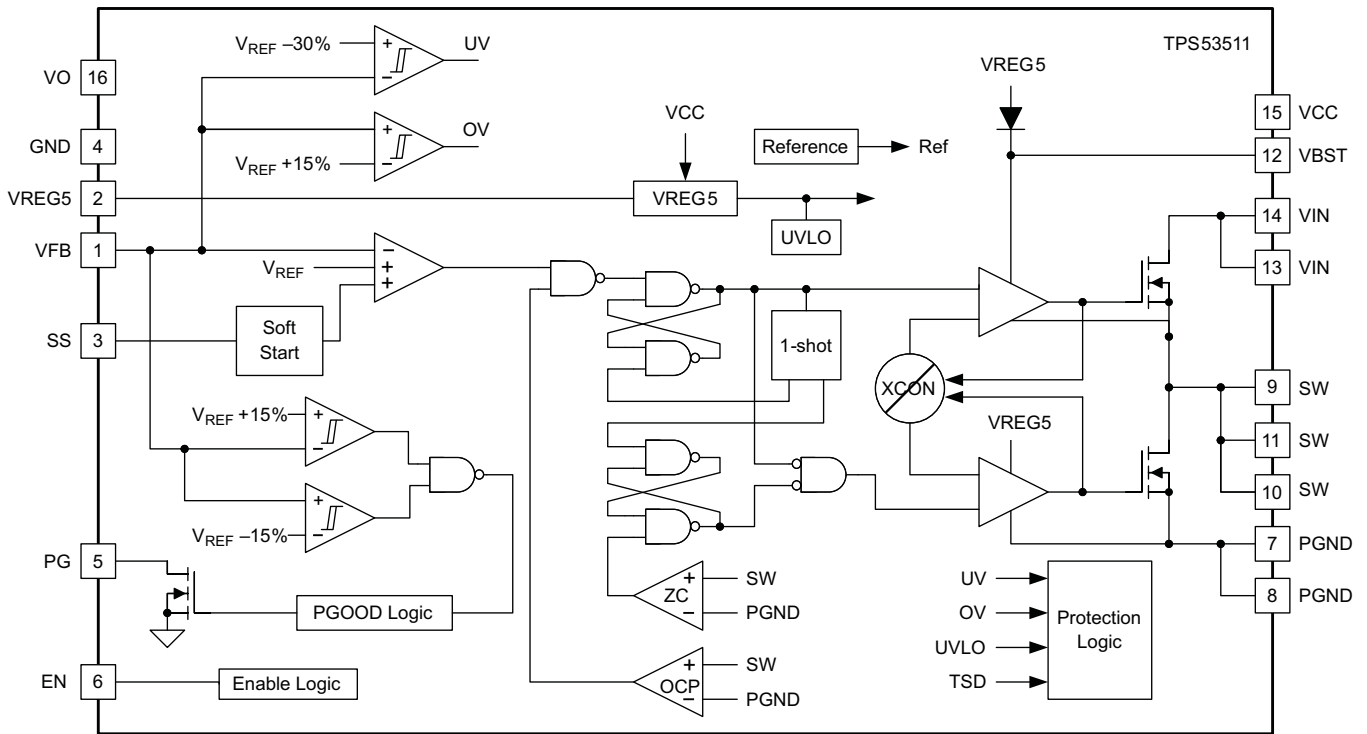

UDG-13088

## DETAILED DESCRIPTION

The TPS53511 is a 1.5-A synchronous step-down (buck) converter with two integrated N-channel MOSFETs. It operates using D-CAP2™ mode control. The fast transient response of D-CAP2™ control reduces the output capacitance required to meet a specific level of performance. Proprietary internal circuitry allows the use of low ESR output capacitors including ceramic and special polymer types.

### PWM Operation

The main control loop of the TPS53511 is an adaptive on-time pulse width modulation (PWM) controller that supports a proprietary D-CAP2™ mode control. D-CAP2™ mode control combines constant on-time control with an internal compensation circuit for pseudo-fixed frequency and low external component count configuration with both low ESR and ceramic output capacitors. It is stable even with virtually no ripple at the output.

At the beginning of each cycle, the high-side MOSFET is turned on. This MOSFET is turned off after internal one shot timer expires. This one shot timer is set by the converter input voltage,  $V_{IN}$ , and the output voltage,  $V_{VO}$ , to maintain a pseudo-fixed frequency over the output voltage range, hence it is called adaptive on-time control. The one-shot timer is reset and the high-side MOSFET is turned on again when the feedback voltage falls below the reference voltage. An internal ramp is added to the reference voltage to simulate output ripple, eliminating the need for ESR induced output ripple from D-CAP2™ mode control.

### PWM Frequency and Adaptive On-Time Control

TPS53511 uses an adaptive on-time control scheme and does not have a dedicated on board oscillator. The device runs with a pseudo-constant frequency of 700 kHz by using the input voltage and output voltage to set the on-time one-shot timer. The on-time is inversely proportional to the input voltage and proportional to the output voltage. The actual frequency may vary from 700 kHz depending on the off time, which is ended when the feedback portion of the output voltage falls to the VFB threshold voltage.

### Light Load Mode Control

The TPS53511 is designed with Auto-Skip mode to increase light load efficiency. As the output current decreases from heavy load condition, the inductor current is also reduced and eventually comes to point that its rippled valley touches zero level, which is the boundary between continuous conduction and discontinuous conduction modes. The rectifying MOSFET is turned off when its zero inductor current is detected. As the load current further decreases the converter run into discontinuous conduction mode. The on-time is kept almost the same as is was in the continuous conduction mode so that it takes longer time to discharge the output capacitor with smaller load current to the level of the reference voltage. The transition point to the light load operation  $I_{OUT(LL)}$  current can be calculated in [Equation 1](#).

$$I_{OUT(LL)} = \frac{1}{2 \times L \times f_{SW}} \times \frac{(V_{IN} - V_{OUT}) \times V_{OUT}}{V_{IN}} \quad (1)$$

### Soft-Start and Pre-Biased Soft-Start Function

The soft-start time function is adjustable. When the EN pin becomes high, 2- $\mu$ A current begins charging the capacitor which is connected from the SS pin to GND. Smooth control of the output voltage is maintained during start up. The equation for the slow start time is shown in [Equation 2](#). VFB voltage is 0.765 V and SS pin source current is 2  $\mu$ A.

$$t_{SS(ms)} = \frac{C_{SS} \times V_{REF}}{I_{SS(\mu A)}} = \frac{C_{SS} \times 0.765}{2}$$

where

- $C_{SS}$  is the value of the capacitor connected between the SS pin and GND
- $C_{SS}$  is expressed in nF

(2)

This unique circuit prevents current from being pulled from the output during startup if the output is pre-biased. When the soft-start commands a voltage higher than the pre-bias level (internal soft-start voltage becomes greater than feedback voltage VFB), the controller slowly activates synchronous rectification by starting the first low-side FET gate driver pulses with a narrow on-time. It then increments the on-time on a cycle-by-cycle basis until it coincides with the time dictated by  $(1-D)$ , where D is the duty cycle of the converter. This scheme prevents the initial sinking of the pre-bias output, and ensures that the output voltage (the VO pin) starts and ramps up smoothly into regulation and the control loop is given time to transition from pre-biased start-up to normal mode operation.

### Power Good

The power good function is activated after soft-start has finished. The power good function becomes active after 1.7 times soft-start time. When the feedback voltage is within  $\pm 10\%$  of the target value, internal comparators detect power good state and the power good signal becomes high. The power good output, PG, is an open drain output. When the feedback voltage goes  $\pm 15\%$  outside of the target value, the power good signal becomes low after 10- $\mu\text{s}$  internal delay. During an undervoltage condition, when the feedback voltage returns to be within  $\pm 10\%$  of the target value, the power good signal goes HIGH again.

### Output Discharge Control

TPS53511 discharges the output when EN is low, or the controller is turned off by the protection function (OVP, UVP, UVLO and thermal shutdown). The output is discharged by an internal 50- $\Omega$  MOSFET which is connected from VO to PGND. The internal low-side MOSFET is not turned on during the output discharge operation to avoid the possibility of causing negative voltage at the output.

### Current Protection

Output current is limited by cycle-by-cycle overcurrent limiting control. The inductor current is monitored during the OFF state and the controller keeps the OFF state when the inductor current is larger than the over current trip level. To provide accuracy and a cost-effective solution, the device supports temperature compensated internal MOSFET  $R_{DS(on)}$  sensing.

The inductor current is monitored by the voltage between the PGND pin and the SW pin. In an overcurrent condition, the current to the load exceeds the current to the output capacitor; thus, the output voltage tends to fall off. Eventually the output voltage becomes less than the undervoltage protection threshold and the device shuts down.

### Overvoltage/Undervoltage Protection

The TPS53511 detects over and under-voltage conditions by monitoring the feedback voltage (the VFB pin). This function is enabled after approximately 1.7 times the soft-start time. When the feedback voltage becomes higher than 115% of the target voltage, the OVP comparator output goes high and the circuit latches the high-side MOSFET driver turns off and the low-side MOSFET turns on. Normal operation can be restored only by cycling the VCC or EN pin voltage. When the feedback voltage becomes lower than 70% of the target voltage, the UVP comparator output goes high and an internal UVP delay counter begins. After 250  $\mu\text{s}$ , the device latches off both internal high-side and low-side MOSFET. Similar to the overvoltage protection, the device is latched off, and normal operation can be restored only by cycling the VCC or EN pin voltage.

### UVLO Protection

Undervoltage lockout protection (UVLO) monitors the voltage of the  $V_{VREG5}$  pin. When the  $V_{VREG5}$  voltage is lower than UVLO threshold voltage, the TPS53511 is shut off. This protection is non-latching.

### Thermal Shutdown

Thermal protection is self-activating. If the junction temperature exceeds the threshold value (typically 150°C), the TPS53511 shuts off. This protection is non-latching.

TYPICAL CHARACTERISTICS

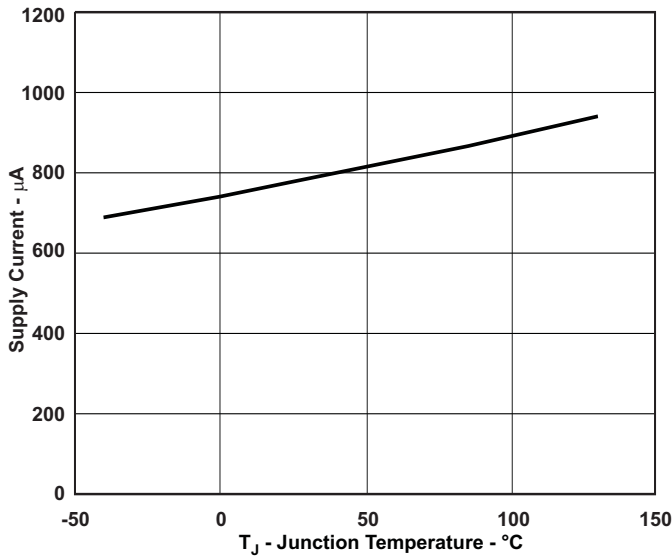

Figure 1. V<sub>CC</sub> SUPPLY CURRENT vs. JUNCTION TEMPERATURE

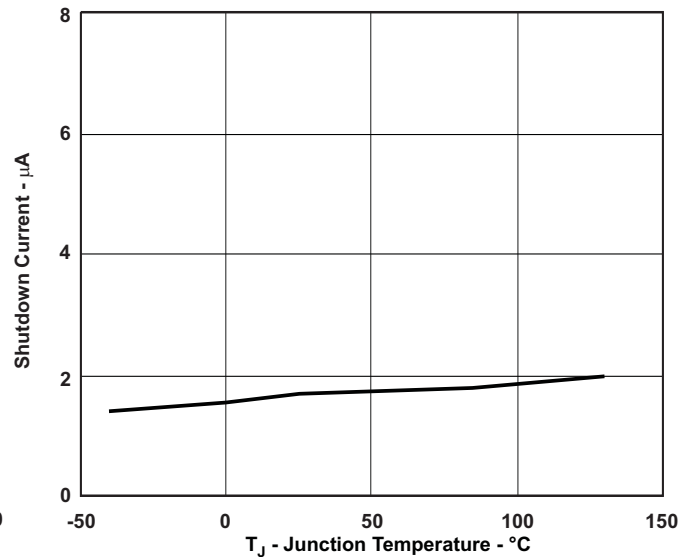

Figure 2. V<sub>CC</sub> SHUTDOWN CURRENT vs. JUNCTION TEMPERATURE

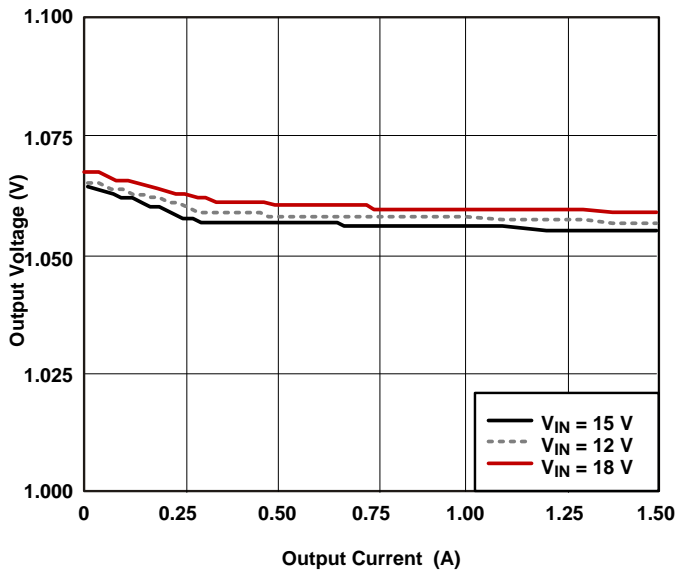

Figure 3. 1.05-V Output Voltage vs. Output Current

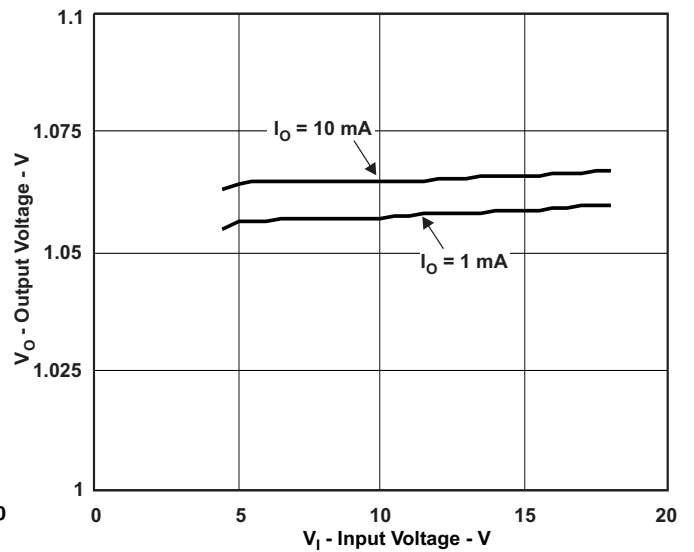

Figure 4. 1.05-V Output Voltage vs. Input Voltage

TYPICAL CHARACTERISTICS (continued)

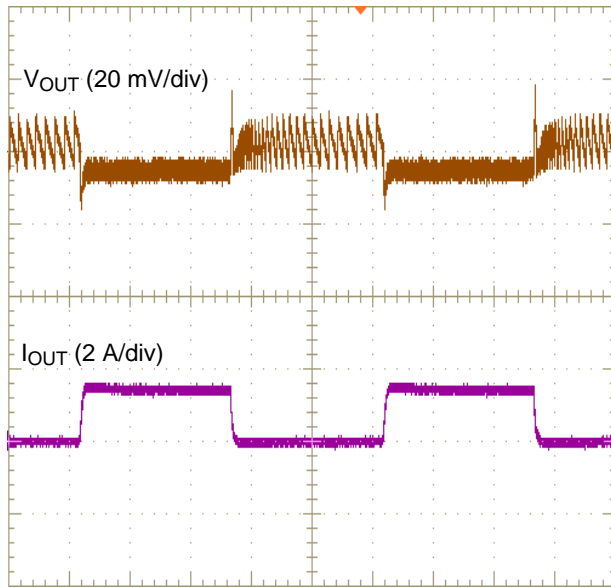

Figure 5. Load Transient Response, 1.05-V, 0-A TO 1.5-A

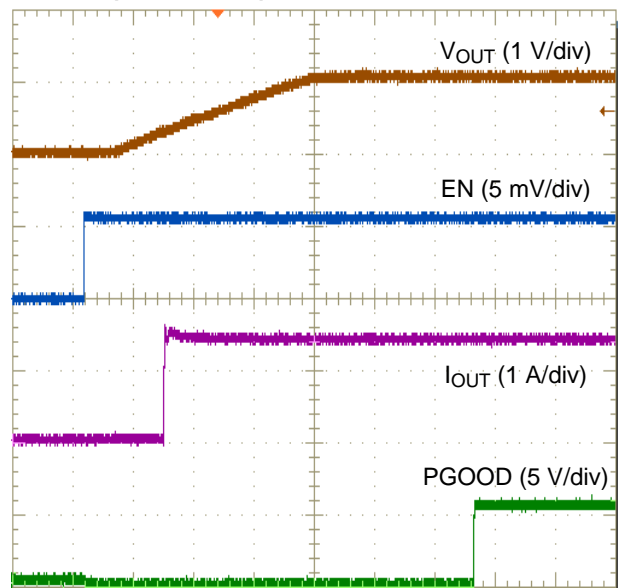

Figure 6. Start-Up

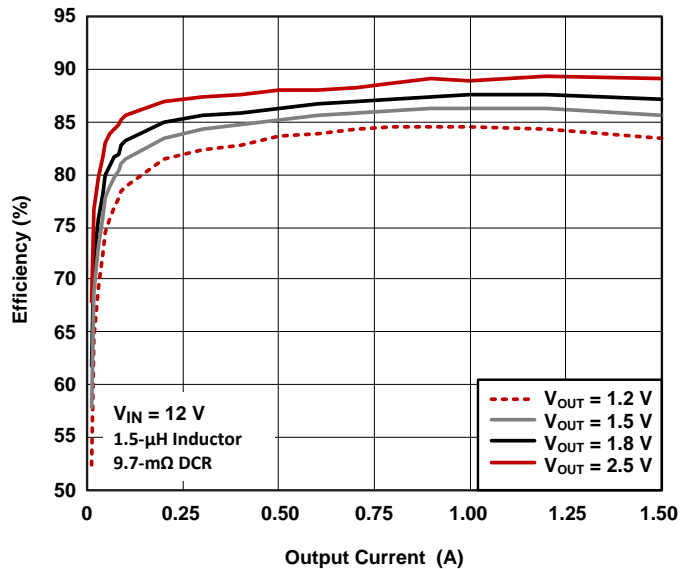

Figure 7. Efficiency vs. Output Current

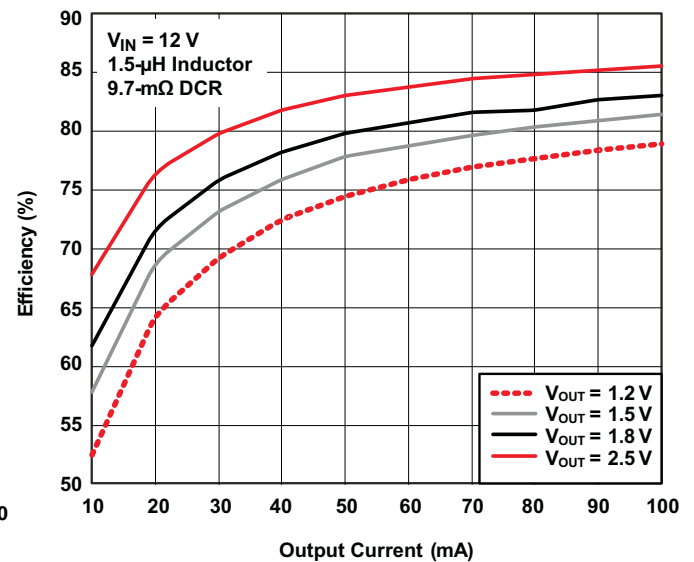

Figure 8. Light Load Efficiency vs. Output Current

TYPICAL CHARACTERISTICS (continued)

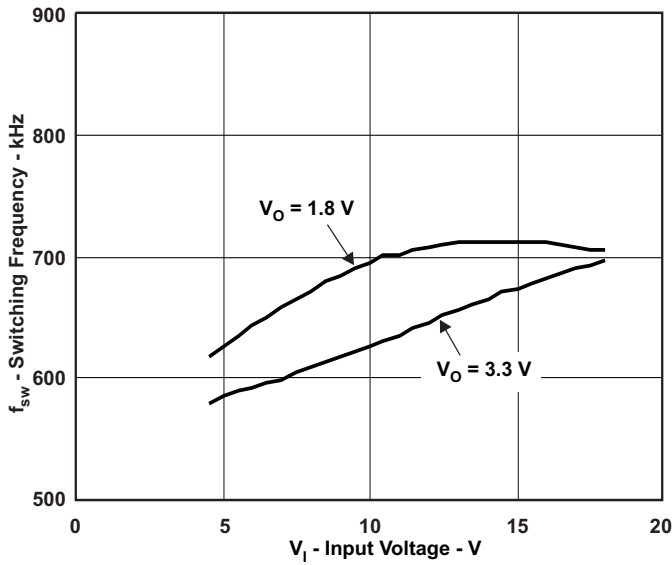

Figure 9. Switching Frequency vs Input Voltage

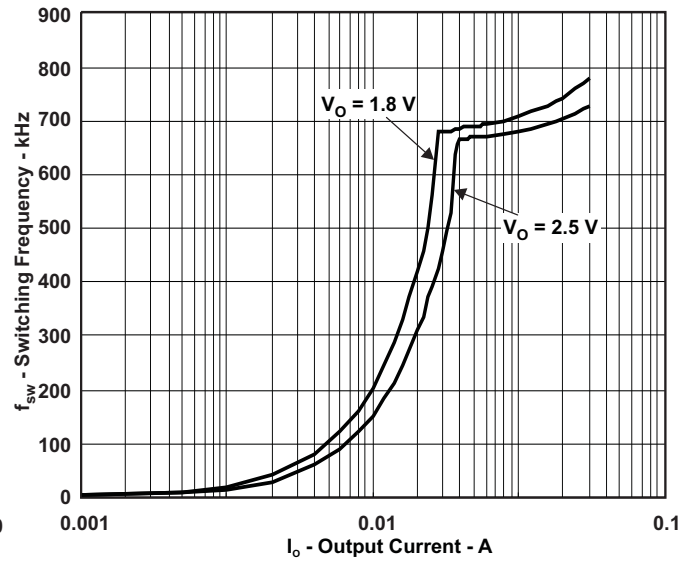

Figure 10. Switching Frequency vs Output Current

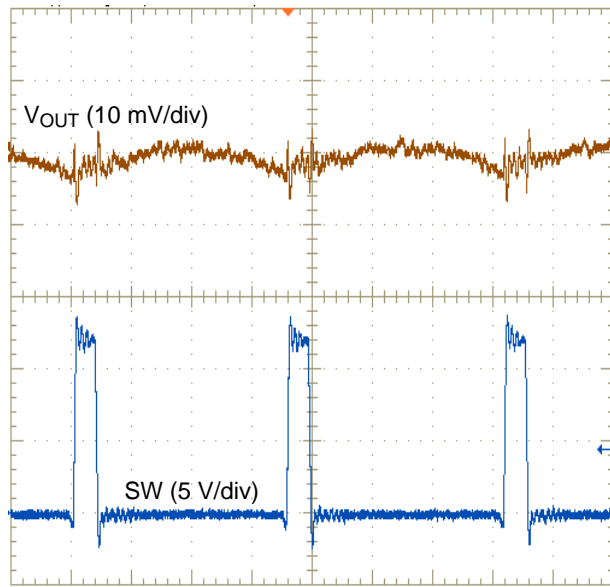

Figure 11. Output Voltage Ripple

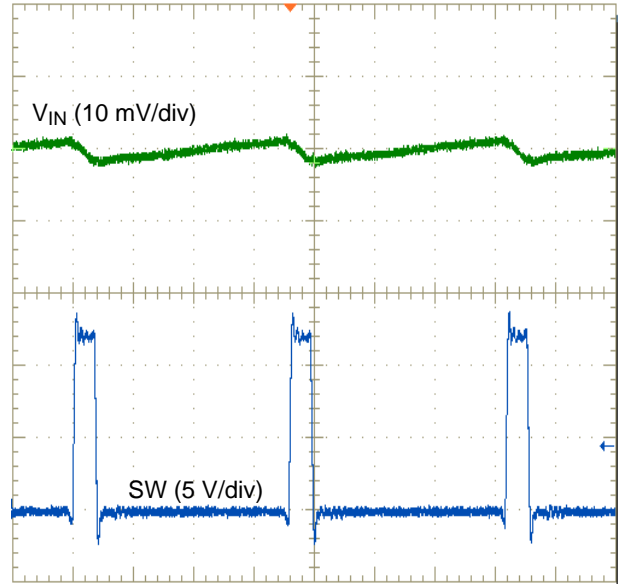

Figure 12. Input Voltage Ripple

## APPLICATION INFORMATION

The following example illustrates the design process and component selection for a single output synchronous buck converter using TPS53511. The schematic of a design example is shown in Figure 13. The specification of the converter is listed in Table 1.

**Table 1. Specification of the Single Output Synchronous Buck Converter**

PARAMETER		TEST CONDITION	MIN	TYP	MAX	UNIT
V <sub>IN</sub>	Input voltage		4.5	12	18	V
V <sub>OUT</sub>	Output voltage			1.05		V
V <sub>RIPPLE</sub>	Output ripple	I <sub>OUT</sub> = 1.5 A		3% of V <sub>OUT</sub>		V
I <sub>OUT</sub>	Output current			1.5		A
f <sub>SW</sub>	Switching frequency			700		kHz

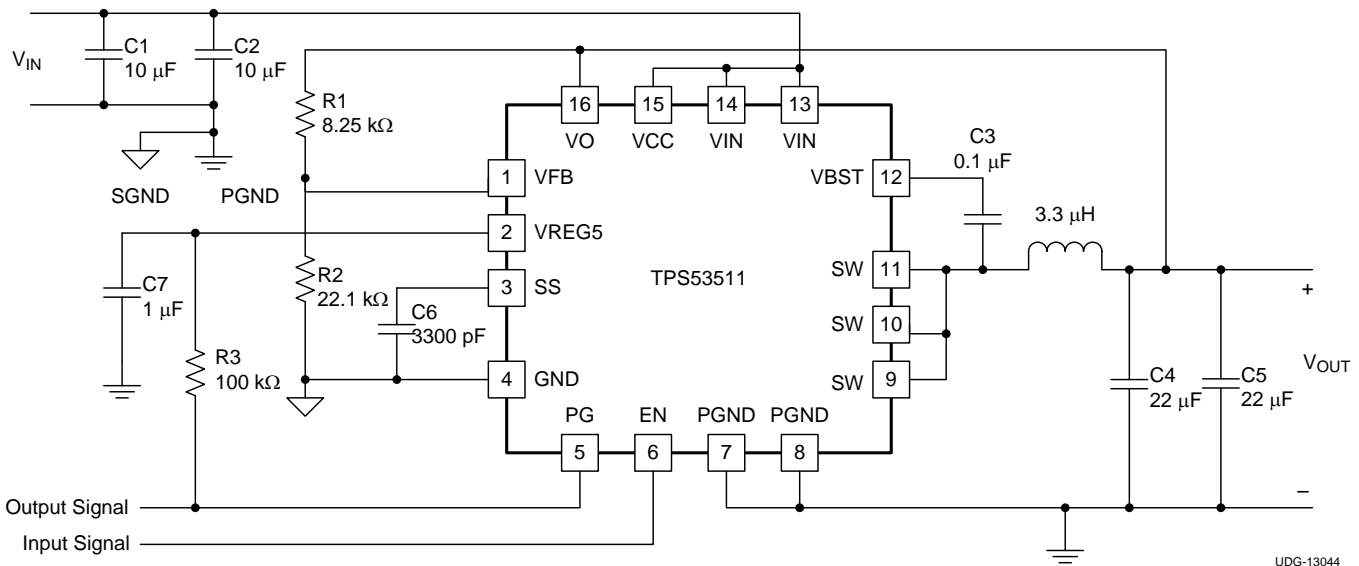

**Figure 13. Typical 12-V Input Application Circuit**

### Output Inductor Selection

The value of the output filtering inductor determines the magnitude of the current ripple, which also affects the output voltage ripple for a certain output capacitance value. Increasing the inductance value reduces the ripple current, and thus, results in reduced conduction loss and output ripple voltage. Alternatively, low inductance value is needed due to the demand of low profile and fast transient response. Therefore, it is important to obtain a compromise between the low ripple current and low inductance value.

In practical application, the peak-to-peak current ripple is usually designed to be between 1/4 to 1/2 of the rated load current. Since the magnitude of the current ripple is determined by inductance value, switching frequency, input voltage and output voltage, the required inductance value for a certain required ripple  $\Delta I$  is shown in Equation 3. Also, the chosen inductor should be rated for the peak current calculated from Equation 4.

$$L = \frac{(V_{IN} - V_{OUT}) \times V_{OUT}}{V_{IN} \times I_{RIPPLE} \times f_{SW}} \quad (3)$$

$$I_{L(\text{peak})} = I_{\text{OUT}} + \left( \frac{I_{\text{RIPPLE}}}{2} \right)$$

where

- $V_{\text{IN}}$  is the input voltage
- $V_{\text{OUT}}$  is the output voltage
- $I_{\text{RIPPLE}}$  is the required current ripple
- $f_{\text{SW}}$  is the switching frequency

(4)

For this design example, the inductance value is selected to provide approximately 30% peak-to-peak ripple current at maximum load. For this design, a nearest standard value was chosen: 3.3  $\mu\text{H}$ . For 3.3  $\mu\text{H}$ , the calculated peak current is 1.71 A.

### Output Capacitor Selection

The capacitor value and ESR determines the amount of output voltage ripple. Recommend to use ceramic output capacitor. Using Equation 5 to Equation 6, an initial estimate for the capacitor value and ESR can be calculated. Of the load transients are significant consider using the load step, instead of ripple current to calculate the maximum ESR.

$$C > \frac{1}{8 \times f_{\text{SW}}} \times \frac{1}{\frac{V_{\text{RIPPLE}}}{I_{\text{RIPPLE}}} - \text{ESR}}$$

(5)

$$\text{ESR} < \frac{V_{\text{OUT(ripple)}}}{I_{\text{RIPPLE}}}$$

(6)

For this design, the minimum required capacitance is 8.45  $\mu\text{F}$  and maximum ESR is 33 m $\Omega$ . Therefore, two TDK C3216JB0J226M 22- $\mu\text{F}$  output capacitors are used. The maximum ESR is 12 m $\Omega$  for each capacitor.

### Input Capacitor Selection

The device requires an input decoupling capacitor and a bulk capacitor. A ceramic capacitor over 10  $\mu\text{F}$  is recommended for the decoupling capacitor. The capacitor voltage rating must to be greater than the maximum input voltage. In case of separate  $V_{\text{VCC}}$  and  $V_{\text{VIN}}$ , a ceramic capacitor over 10  $\mu\text{F}$  is recommended for the input voltage. Placing a ceramic capacitor with a value higher than 0.1- $\mu\text{F}$  for the VCC is recommended also.

### Bootstrap Capacitor Selection

A 0.1- $\mu\text{F}$  capacitor must be connected between the VBST and SW pin for proper operation. A ceramic capacitor is recommended.

### VREG5 Capacitor Selection

A 1- $\mu\text{F}$  capacitor must be connected between the VREG5 and SW pin for proper operation. A ceramic capacitor is recommended.

## Output Voltage Setting Resistors Selection

The output voltage is set with a resistor divider from the output node to the VFB pin. It is recommended to use 1% tolerance or better divider resistors. Begin by using [Equation 7](#) and [Equation 8](#) to calculate  $V_{OUT}$ .

To improve efficiency at light-load condition, use resistors with a relatively larger value. However, too high resistance value make the circuit more susceptible to noise, and voltage errors from the VFB input current is more noticeable.

**For output voltages from 0.76 V to 2.5 V:**

$$V_{OUT} = 0.765 \times \left( 1 + \left( \frac{R1}{R2} \right) \right) \quad (7)$$

**For output voltages over 2.5 V:**

$$V_{OUT} = (0.763 + 0.0017 \times V_{OUT}) \times \left( 1 + \frac{R1}{R2} \right) \quad (8)$$

The required output voltage for this design is 1.05 V. So [Equation 7](#) is used to calculate the value of R1. R2 is 22.1 k $\Omega$ , therefore, R1 is 8.25 k $\Omega$ .

## Thermal Information

This PowerPAD™ package incorporates an exposed thermal pad that is designed to be connected to an external heat sink. The thermal pad must be soldered directly to the printed board (PCB). After soldering, the PCB can be used as a heat sink. In addition, through the use of thermal vias, the thermal pad can be attached directly to the appropriate copper plane shown in the electrical schematic for the device, or alternatively, can be attached to a special heat sink structure designed into the PCB. This design optimizes the heat transfer from the device.

For additional information on the PowerPAD™ package and how to use the advantage of its heat dissipating abilities, refer to Technical Brief, *PowerPAD™ Thermally Enhanced Package*, Texas Instruments Literature Number [SLMA002](#) and Application Brief, *PowerPAD™ Made Easy*, Texas Instruments Literature Number [SLMA004](#)

## Layout Considerations

- Keep the input switching current loop as small as possible
- Keep the SW node as physically small and short as possible to minimize parasitic capacitance and inductance and to minimize radiated emissions. Kelvin connections should be brought from the output to the feedback pin of the device.
- Keep analog and non-switching components away from switching components.
- Make a single point connection between the signal and power grounds.
- Do not allow switching current to flow under the device.
- Keep the pattern lines for VIN and PGND broad.
- Exposed pad of the device must be connected to PGND with solder.
- VREG5 capacitor should be connected to a broad pattern of the PGND.
- Output capacitor should be connected to a broad pattern of the PGND.
- Voltage feedback loop should be as short as possible, and preferably with ground shield.
- Lower resistor of the voltage divider which is connected to the VFB pin should be tied to SGND.
- Providing sufficient via is preferable for VIN, SW and PGND connection.
- PCB pattern for VIN, SW and PGND should be as broad as possible.
- If VIN and VCC are shorted, VIN and VCC patterns need to be connected with broad pattern lines.
- VIN capacitor should be placed as close as possible to the device.

**Changes from Original (MARCH 2013) to Revision A**

**Page**

---

• Changed minimum value for Current limit specification in Electrical characteristics table .....	4
• Changed <a href="#">Figure 3</a> .....	10
• Changed <a href="#">Figure 5</a> .....	11
• Changed <a href="#">Figure 6</a> .....	11
• Changed <a href="#">Figure 7</a> .....	11
• Changed <a href="#">Figure 11</a> .....	12
• Changed <a href="#">Figure 12</a> .....	12
• Changed <a href="#">Figure 13</a> .....	13

---

**PACKAGING INFORMATION**

Orderable Device	Status (1)	Package Type	Package Drawing	Pins	Package Qty	Eco Plan (2)	Lead/Ball Finish (6)	MSL Peak Temp (3)	Op Temp (°C)	Device Marking (4/5)	Samples
HPA02165RGTR	ACTIVE	VQFN	RGT	16	3000	Green (RoHS & no Sb/Br)	NIPDAU	Level-2-260C-1 YEAR	-40 to 85	53511	<a href="#">Samples</a>
TPS53511RGTR	ACTIVE	VQFN	RGT	16	3000	Green (RoHS & no Sb/Br)	NIPDAU	Level-2-260C-1 YEAR	-40 to 85	53511	<a href="#">Samples</a>
TPS53511RGTT	ACTIVE	VQFN	RGT	16	250	Green (RoHS & no Sb/Br)	NIPDAU	Level-2-260C-1 YEAR	-40 to 85	53511	<a href="#">Samples</a>

(1) The marketing status values are defined as follows:

**ACTIVE:** Product device recommended for new designs.

**LIFEBUY:** TI has announced that the device will be discontinued, and a lifetime-buy period is in effect.

**NRND:** Not recommended for new designs. Device is in production to support existing customers, but TI does not recommend using this part in a new design.

**PREVIEW:** Device has been announced but is not in production. Samples may or may not be available.

**OBSOLETE:** TI has discontinued the production of the device.

(2) **RoHS:** TI defines "RoHS" to mean semiconductor products that are compliant with the current EU RoHS requirements for all 10 RoHS substances, including the requirement that RoHS substance do not exceed 0.1% by weight in homogeneous materials. Where designed to be soldered at high temperatures, "RoHS" products are suitable for use in specified lead-free processes. TI may reference these types of products as "Pb-Free".

**RoHS Exempt:** TI defines "RoHS Exempt" to mean products that contain lead but are compliant with EU RoHS pursuant to a specific EU RoHS exemption.

**Green:** TI defines "Green" to mean the content of Chlorine (Cl) and Bromine (Br) based flame retardants meet JS709B low halogen requirements of <=1000ppm threshold. Antimony trioxide based flame retardants must also meet the <=1000ppm threshold requirement.

(3) MSL, Peak Temp. - The Moisture Sensitivity Level rating according to the JEDEC industry standard classifications, and peak solder temperature.

(4) There may be additional marking, which relates to the logo, the lot trace code information, or the environmental category on the device.

(5) Multiple Device Markings will be inside parentheses. Only one Device Marking contained in parentheses and separated by a "-" will appear on a device. If a line is indented then it is a continuation of the previous line and the two combined represent the entire Device Marking for that device.

(6) Lead/Ball Finish - Orderable Devices may have multiple material finish options. Finish options are separated by a vertical ruled line. Lead/Ball Finish values may wrap to two lines if the finish value exceeds the maximum column width.

**Important Information and Disclaimer:** The information provided on this page represents TI's knowledge and belief as of the date that it is provided. TI bases its knowledge and belief on information provided by third parties, and makes no representation or warranty as to the accuracy of such information. Efforts are underway to better integrate information from third parties. TI has taken and continues to take reasonable steps to provide representative and accurate information but may not have conducted destructive testing or chemical analysis on incoming materials and chemicals. TI and TI suppliers consider certain information to be proprietary, and thus CAS numbers and other limited information may not be available for release.

In no event shall TI's liability arising out of such information exceed the total purchase price of the TI part(s) at issue in this document sold by TI to Customer on an annual basis.

**TAPE AND REEL INFORMATION**

**QUADRANT ASSIGNMENTS FOR PIN 1 ORIENTATION IN TAPE**

\*All dimensions are nominal

Device	Package Type	Package Drawing	Pins	SPQ	Reel Diameter (mm)	Reel Width W1 (mm)	A0 (mm)	B0 (mm)	K0 (mm)	P1 (mm)	W (mm)	Pin1 Quadrant
TPS53511RGTR	VQFN	RGT	16	3000	330.0	12.4	3.3	3.3	1.1	8.0	12.0	Q2
TPS53511RGTT	VQFN	RGT	16	250	180.0	12.4	3.3	3.3	1.1	8.0	12.0	Q2

**TAPE AND REEL BOX DIMENSIONS**

\*All dimensions are nominal

Device	Package Type	Package Drawing	Pins	SPQ	Length (mm)	Width (mm)	Height (mm)
TPS53511RGTR	VQFN	RGT	16	3000	367.0	367.0	35.0
TPS53511RGTT	VQFN	RGT	16	250	210.0	185.0	35.0

**RGT 16**

**GENERIC PACKAGE VIEW**

**VQFN - 1 mm max height**

PLASTIC QUAD FLATPACK - NO LEAD

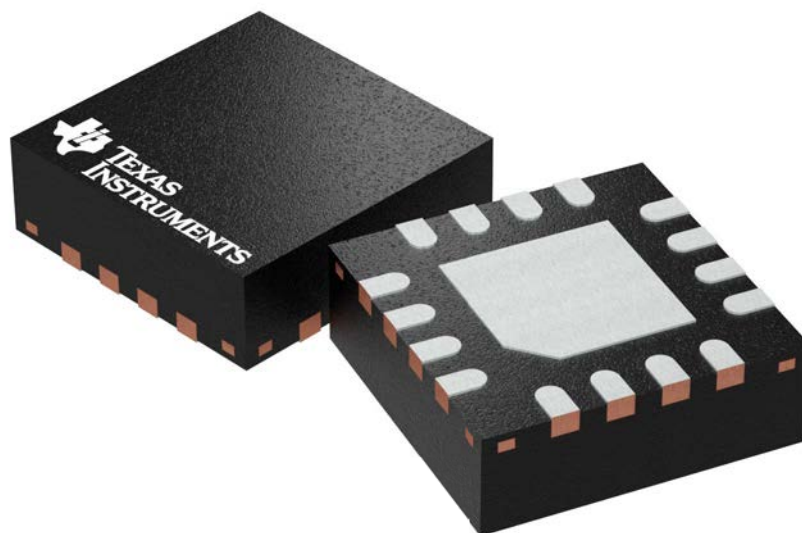

Images above are just a representation of the package family, actual package may vary.  
Refer to the product data sheet for package details.

4203495/1

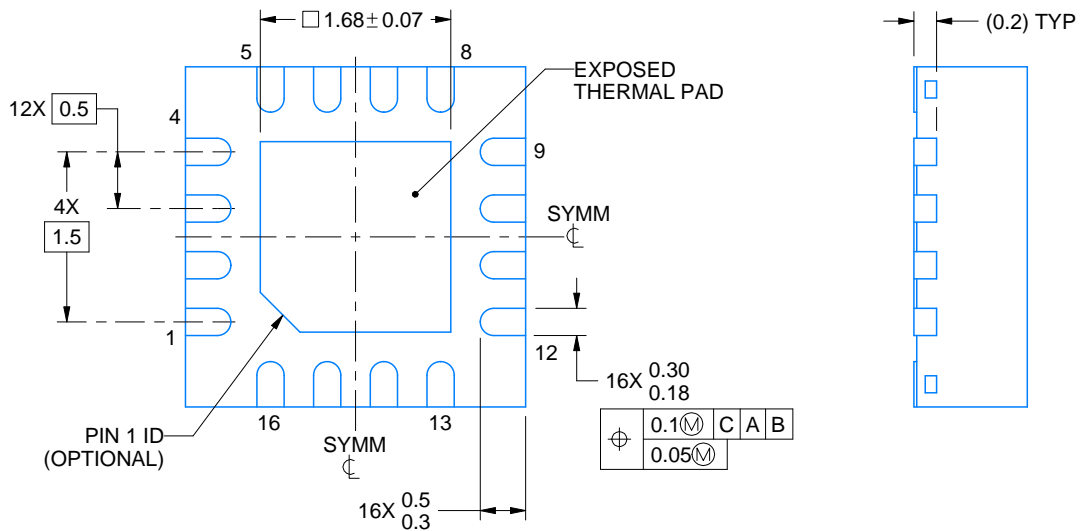
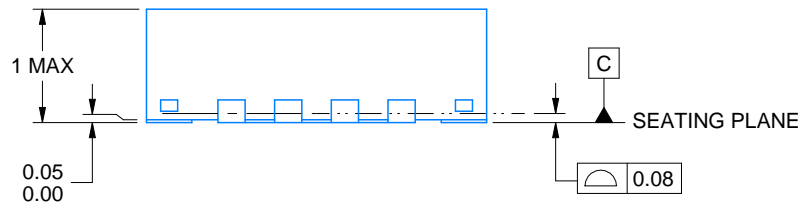
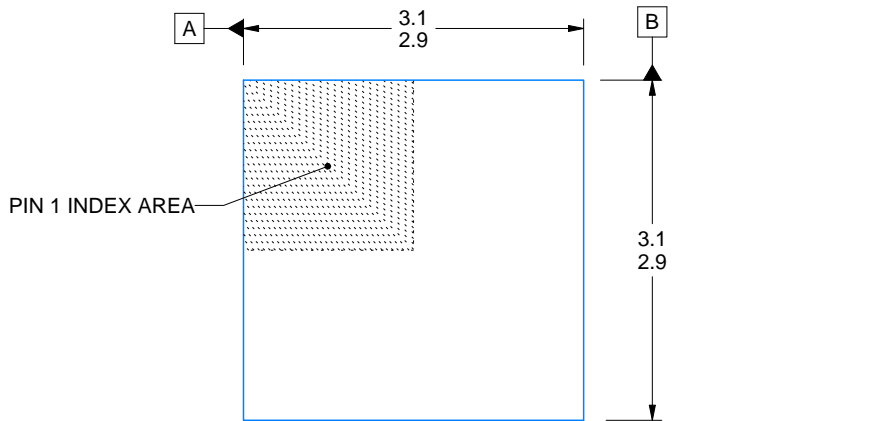
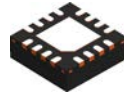

4222419/B 11/2016

NOTES:

1. All linear dimensions are in millimeters. Any dimensions in parenthesis are for reference only. Dimensioning and tolerancing per ASME Y14.5M.
2. This drawing is subject to change without notice.
3. The package thermal pad must be soldered to the printed circuit board for thermal and mechanical performance.

# EXAMPLE BOARD LAYOUT

RGT0016C

VQFN - 1 mm max height

PLASTIC QUAD FLATPACK - NO LEAD

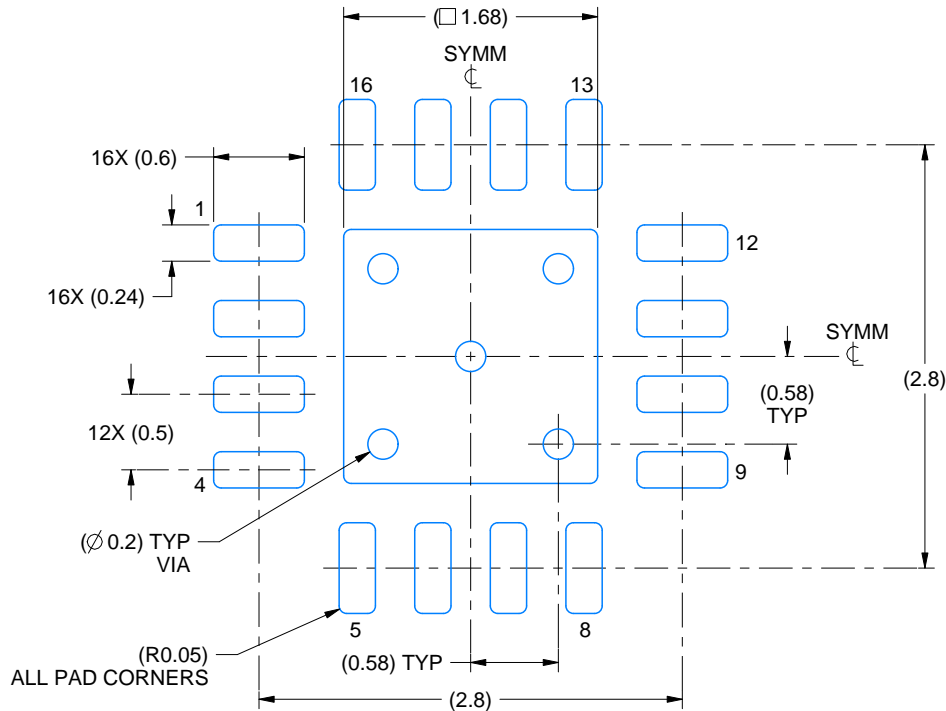

LAND PATTERN EXAMPLE  
SCALE:20X

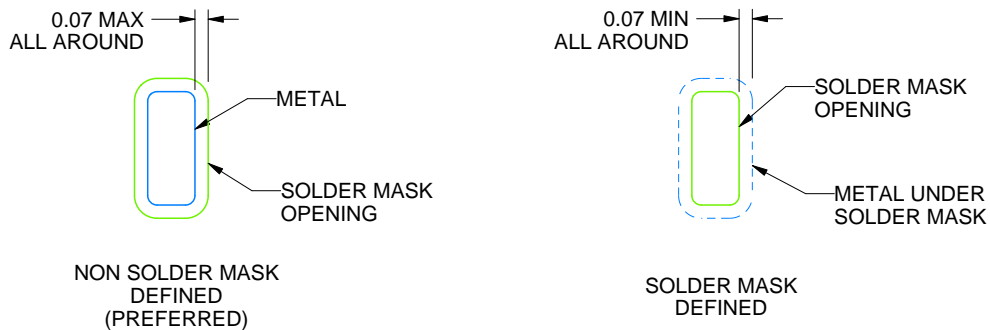

SOLDER MASK DETAILS

4222419/B 11/2016

NOTES: (continued)

- This package is designed to be soldered to a thermal pad on the board. For more information, see Texas Instruments literature number SLUA271 ([www.ti.com/lit/slua271](http://www.ti.com/lit/slua271)).
- Vias are optional depending on application, refer to device data sheet. If any vias are implemented, refer to their locations shown on this view. It is recommended that vias under paste be filled, plugged or tented.

# EXAMPLE STENCIL DESIGN

RGT0016C

VQFN - 1 mm max height

PLASTIC QUAD FLATPACK - NO LEAD

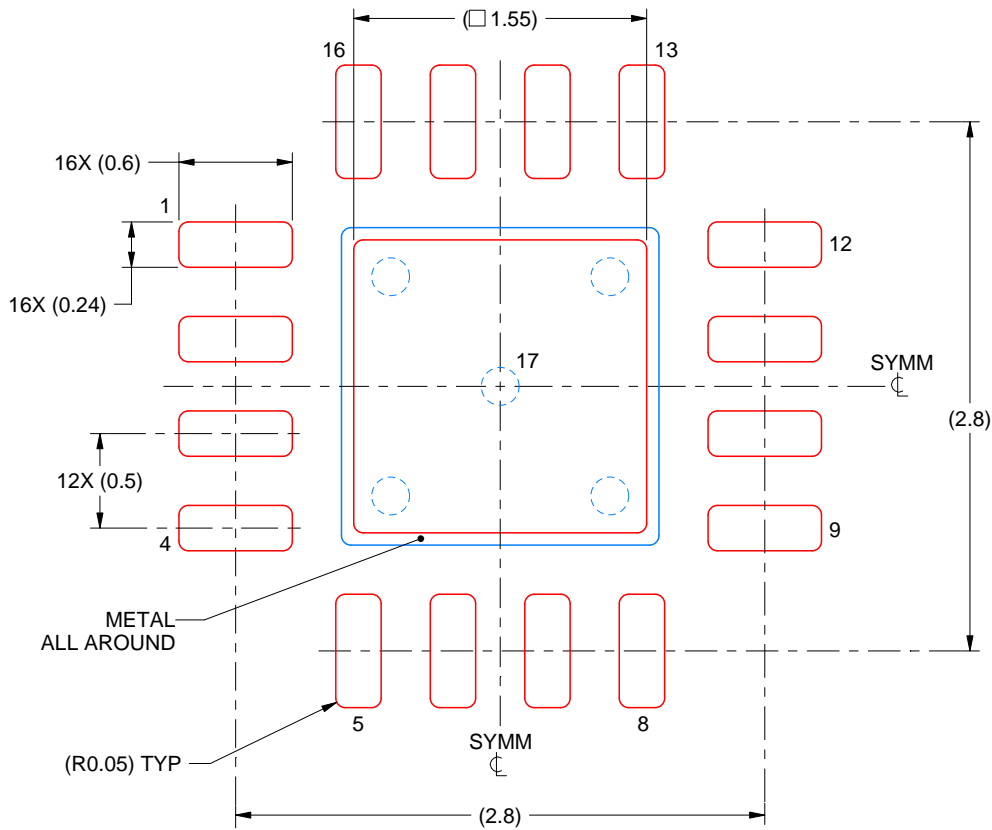

**SOLDER PASTE EXAMPLE**  
BASED ON 0.125 mm THICK STENCIL

EXPOSED PAD 17:  
85% PRINTED SOLDER COVERAGE BY AREA UNDER PACKAGE  
SCALE:25X

4222419/B 11/2016

NOTES: (continued)

6. Laser cutting apertures with trapezoidal walls and rounded corners may offer better paste release. IPC-7525 may have alternate design recommendations.

## IMPORTANT NOTICE AND DISCLAIMER

TI PROVIDES TECHNICAL AND RELIABILITY DATA (INCLUDING DATASHEETS), DESIGN RESOURCES (INCLUDING REFERENCE DESIGNS), APPLICATION OR OTHER DESIGN ADVICE, WEB TOOLS, SAFETY INFORMATION, AND OTHER RESOURCES "AS IS" AND WITH ALL FAULTS, AND DISCLAIMS ALL WARRANTIES, EXPRESS AND IMPLIED, INCLUDING WITHOUT LIMITATION ANY IMPLIED WARRANTIES OF MERCHANTABILITY, FITNESS FOR A PARTICULAR PURPOSE OR NON-INFRINGEMENT OF THIRD PARTY INTELLECTUAL PROPERTY RIGHTS.

These resources are intended for skilled developers designing with TI products. You are solely responsible for (1) selecting the appropriate TI products for your application, (2) designing, validating and testing your application, and (3) ensuring your application meets applicable standards, and any other safety, security, or other requirements. These resources are subject to change without notice. TI grants you permission to use these resources only for development of an application that uses the TI products described in the resource. Other reproduction and display of these resources is prohibited. No license is granted to any other TI intellectual property right or to any third party intellectual property right. TI disclaims responsibility for, and you will fully indemnify TI and its representatives against, any claims, damages, costs, losses, and liabilities arising out of your use of these resources.

TI's products are provided subject to TI's Terms of Sale ([www.ti.com/legal/termsofsale.html](http://www.ti.com/legal/termsofsale.html)) or other applicable terms available either on [ti.com](http://ti.com) or provided in conjunction with such TI products. TI's provision of these resources does not expand or otherwise alter TI's applicable warranties or warranty disclaimers for TI products.

Mailing Address: Texas Instruments, Post Office Box 655303, Dallas, Texas 75265  
Copyright © 2020, Texas Instruments Incorporated