

Click [here](#) for production status of specific part numbers.

MAX16923

Automotive 4-Output Display Power Solution with Watchdog

General Description

The MAX16923 is a 4-channel power-management IC designed to accommodate the main rails used in modern automotive TFT displays. The MAX16923 and the MAX20069 TFT power supply and LED backlight driver combine to provide a two-chip solution to all automotive display power supply requirements.

The MAX16923 integrates a high-voltage buck converter that transforms battery voltages into a 5V or 3.3V intermediate rail. In addition, a high-voltage, always-on, low quiescent current linear regulator supplies power at 3.3V.

The low-voltage section consists of a fully-integrated DC/DC converter and an LDO running off the intermediate rail. Section output power is available in several low-voltage combinations (see the Ordering Information table). In addition, an integrated watchdog timer guards against run-away code.

A single START control pin initiates the start-up sequence, thereby simplifying device control. The MAX16923's external pMOSFET control block allows battery voltage to be switched to a downstream device, such as a backlight boost converter.

The MAX16923 is available in a TQFN package and operates in the -40°C to 105°C temperature range.

Applications

- Infotainment Displays
- Central Information Displays
- Instrument Clusters

Benefits and Features

- High Integration
 - Complete Display Power Solution from Automotive Battery
 - One High-Voltage 2.1A Buck Converter (5V or 3.3V)
 - One High-Voltage 100mA Low-I_Q Linear Regulator (3.3V)
 - One Low-Voltage 1.6A Buck Converter (3.3V, 1.8V, 1.2V, or 1.1V)
 - One Low-Voltage Linear Regulator (3.3V, 1.8V, 1.5V, or 1.0V)
 - MAX16923GTPB: 75mA
 - MAX16923GTPC/MAX16923GTPE: 175mA
 - All other variants: 180mA
 - Power-Good Outputs
- Integrated Watchdog Timer
- Robust and Low EMI
 - Programmable Switching Frequency
 - Internal Spread Spectrum Oscillator
 - Slew-Rate Controlled Switching
 - Thermal Shutdown Protection
- Compact TQFN20 4mm x 4mm Package

Ordering Information appears at end of datasheet.

Simplified Block Diagram

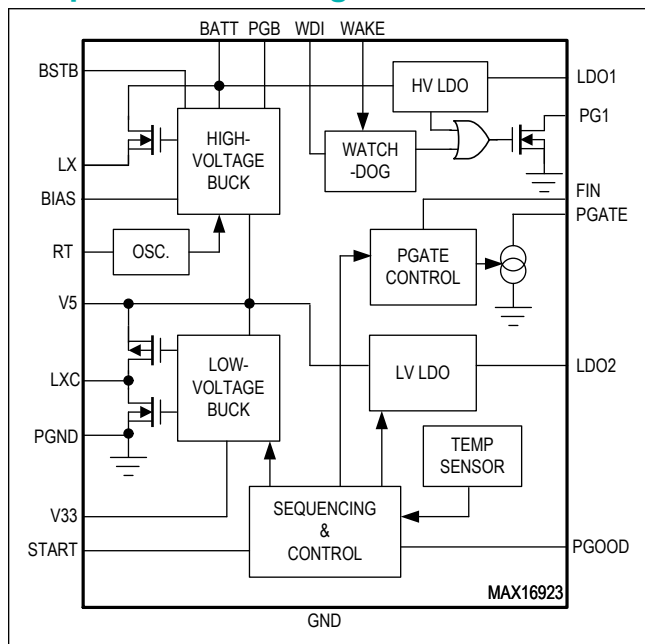

2. Keep the high-current paths short, especially at the ground terminals. This practice is essential for stable, jitter-free operation. The high current path—consisting of the input capacitor, the MAX16923 internal FETs, the inductor, the external diode, and the output capacitor—should be as short as possible.
3. Keep the power traces and load connections short. This practice is essential to achieving high efficiency. Use thick copper PCBs (2oz as opposed to 1oz) to enhance full-load efficiency.
4. Place the BIAS bypass capacitor as close as possible to the BIAS pin.
5. Refer to the MAX16923EVKIT evaluation kit for an example of an optimal layout template.

Typical Application Circuits

MAX16923A - HV Buck Operating at 400KHz

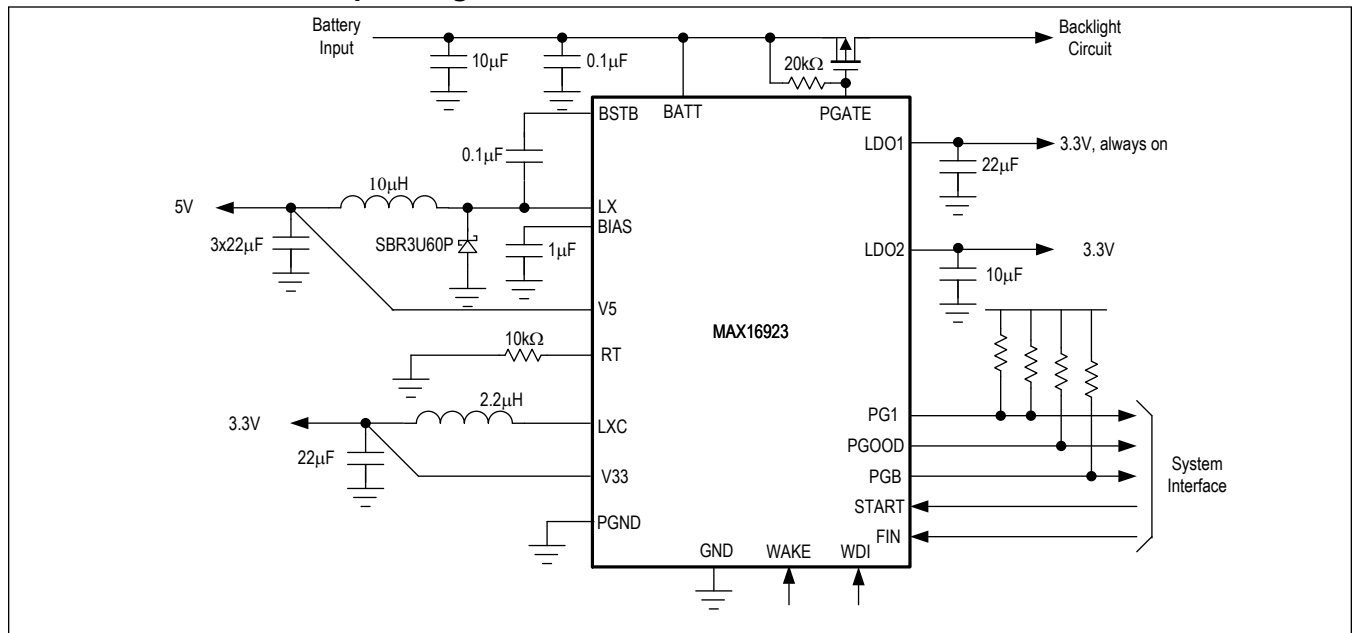

Typical Application Circuits (continued)

MAX16923A - HV Buck Operating at 2MHz

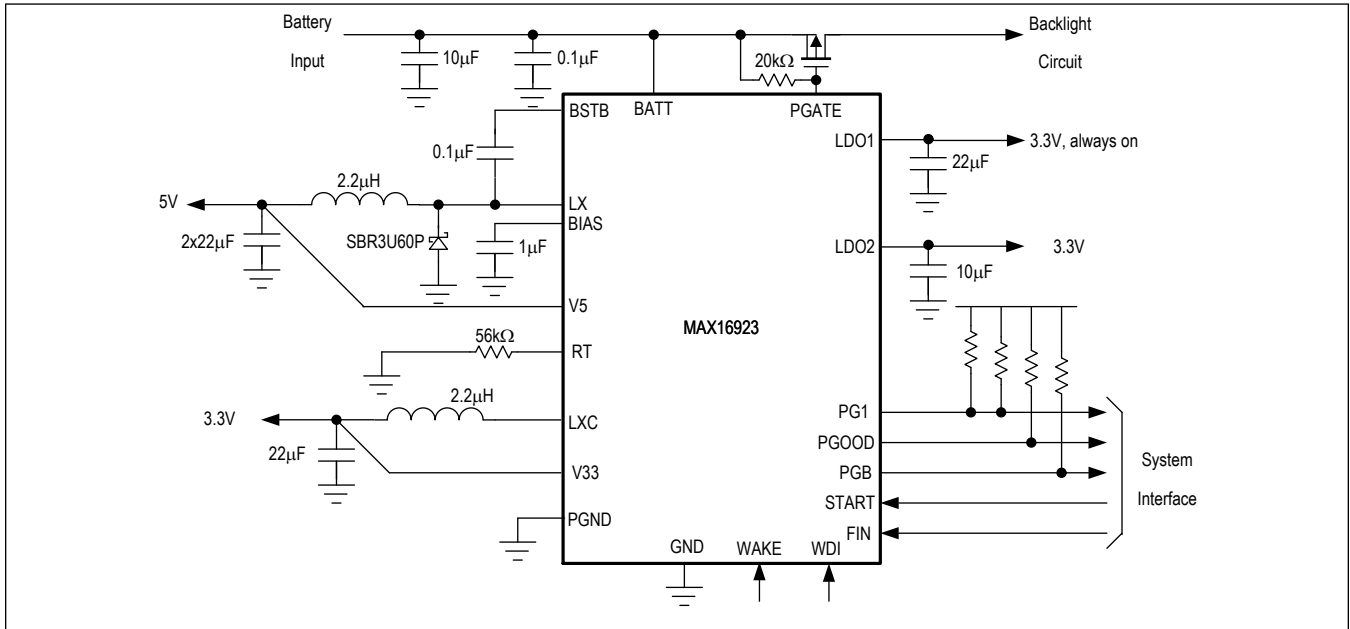

Ordering Information

PART NUMBER	TEMP RANGE	PIN_PACKAGE	V5 SETTING	V33 SETTING	LDO2 SETTING
MAX16923GTPA/V+	-40°C to +105°C	20 TQFN-EP	5V	3.3V	3.3V
MAX16923GTPB/V+**	-40°C to +105°C	20 TQFN-EP	3.3V	1.2V	3.3V
MAX16923GTPC/V+	-40°C to +105°C	20 TQFN-EP	3.3V	1.1V	1.8V
MAX16923GTPD/V+**	-40°C to +105°C	20 TQFN-EP	5V	1.1V	1.8V
MAX16923GTPE/V+**	-40°C to +105°C	20 TQFN-EP	3.3V	1.8V	1.8V
MAX16923GTPF/V+**	-40°C to +105°C	20 TQFN-EP	3.3V	1.8V	1V
MAX16923GTPG/V+**	-40°C to +105°C	20 TQFN-EP	3.3V	1.8V	1.5V

+ Denotes a lead(Pb)-free/RoHS-compliant package.

T Denotes tape-and-reel.

/V Denotes an automotive qualified part

** Future product - contact factory for availability