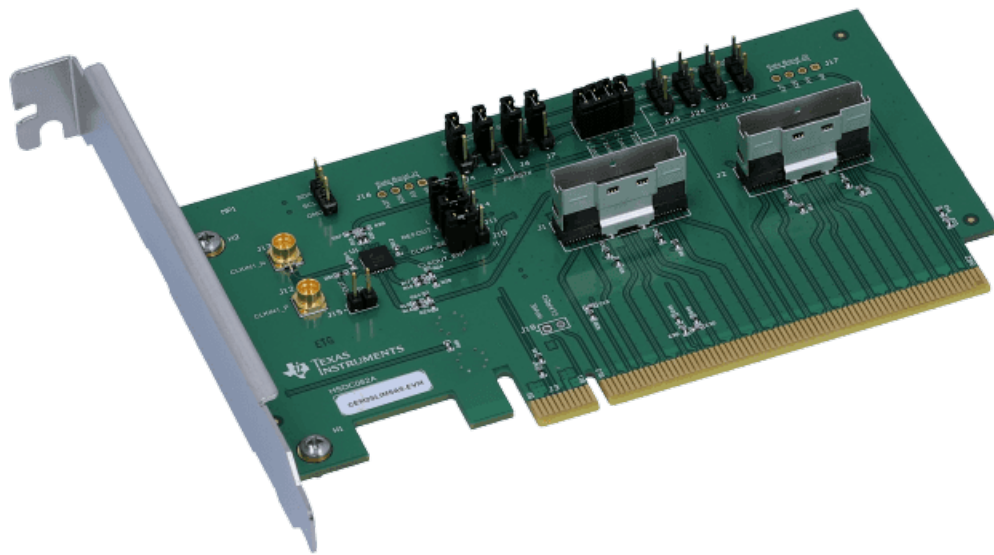


## ***CEM2SLIMSAS-EVM Evaluation Module (EVM)***

The CEM2SLIMSAS-EVM together with the DS160PR410EVM-RSC, or other Texas Instrument's riser-card style PCI-Express 4.0 redriver or retimer evaluation module, provide a complete high-bandwidth platform for evaluating the signal conditioning features of the Texas Instruments PCI-Express 4.0 linear redrivers and retimers. These evaluation boards can be used for standard compliance testing, performance evaluation, and initial system prototyping.



**Figure 1. CEM2SLIMSAS-EVM - Top Side Photo**

### Contents

1	Introduction .....	3
	1.1 Features.....	3
	1.2 Applications.....	3
	1.3 Description.....	3
	1.4 Quick-Start Guide.....	5
2	Typical Test Setup.....	5
3	Board Layout .....	6
4	Schematic and Bill of Materials .....	7
	4.1 Schematic.....	8
	4.2 Bill of Materials .....	15
5	References .....	18

### List of Figures

1	CEM2SLIMSAS-EVM - Top Side Photo .....	1
2	Example Test Setup .....	5
3	Top Layer .....	6
4	Bottom Layer .....	7
5	Top Level Schematic Page.....	8

---

6	Controls Schematic Page.....	9
7	Clock Distribution Schematic Page .....	10
8	Goldfinger Connector Schematic Page .....	11
9	SlimSAS Connector 1 Schematic Page .....	12
10	SlimSAS Connector 2 Schematic Page .....	13
11	Hardware Page .....	14

#### List of Tables

1	Main Connectors and Access Points.....	3
2	PCIe Side Band Signal Controls.....	3
3	PCIe Reference Clock Controls and Access Points .....	4
4	Bill of Materials .....	15

#### Trademarks

All trademarks are the property of their respective owners.

## 1 Introduction

CEM2SLIMSAS-EVM is a PCI-Express 4.0 x16 to two x8 SlimSAS (SFF-8654) adapter. It enables DS160PR410EVM-RSC and other Texas Instruments PCI-Express 4.0 redriver or retimer riser card evaluation modules to interface to up to four U.2 solid state drives (SSDs) using commercially available SlimSAS (SFF-8654) to U.2 (SFF-8639) cable assemblies (not included). Interface to M.2 SSDs is also possible using commercially available U.2 to M.2 adapter cards (not included).

CEM2SLIMSAS-EVM features Texas instruments LMK00334 PCI-Express 4.0 clock buffer for distributing the PCI-Express 100 MHz reference clock to downstream SSDs. It also allows flexible assignment of the PCI-Express side band signals using jumpers.

### 1.1 Features

- PCIe-Express CEM 4.0 compliant Goldfinger connector
- Two x8 SlimSAS (SFF-8654) connectors
- LMK00334 PCI-Express 4.0 clock buffer
- Flexible assignment of PCI-Express side band signals
- Supports PCI-Express 1 x4, 2 x4, and 4 x4 bifurcation

### 1.2 Applications

- PCI Express Gen-1, 2, 3, and 4
- Enterprise storage

### 1.3 Description

#### 1.3.1 Connectors and Access Points

Table 1 shows CEM2SLIMSAS-EVM main connectors and access points.

**Table 1. Main Connectors and Access Points**

COMPONENT	NAME	FUNCTION / DESCRIPTION
J1	PCIe 4.0 x8 SlimSAS Connector 1	Access points to PCIe lanes 0 - 7. Use a SlimSAS (SFF-8654) to U.2 (SFF-8639) cable assembly (not included) to interface to SSDs with U.2 form factor.
J2	PCIe 4.0 x8 SlimSAS Connector 1	Access points to PCIe lanes 8 - 15. Use a SlimSAS (SFF-8654) to U.2 (SFF-8639) cable assembly (not included) to interface to SSDs with U.2 form factor.
J3	PCIe CEM 4.0 x16 Goldfinger Connector	Access points to PCIe lanes 0 - 15. Plug into a PCIe x16 CEM slot.
J8	3x1 Header	I2C bus access point.
J18	2x1 Header	Access point to WAKE and CLKREQ pins on the CEM connector.

Table 2 shows PCIe side band signal controls and access points.

**Table 2. PCIe Side Band Signal Controls**

COMPONENT	NAME	FUNCTION / DESCRIPTION
J4	3x1 Header	Provision for connecting PERST# signal from the CEM connector to B11 or B12 pin of SlimSAS connector J1. Shunt installed across pins 1-2: PERST# signal routed to B11 pin of SlimSAS connector J1. Shunt installed across pins 2-3: PERST# signal routed to B12 pin of SlimSAS connector J1 (default).

**Table 2. PCIe Side Band Signal Controls (continued)**

COMPONENT	NAME	FUNCTION / DESCRIPTION
J5	3x1 Header	Provision for connecting PERST# signal from the CEM connector to B29 or B30 pin of SlimSAS connector J1. Shunt installed across pins 1-2: PERST# signal routed to B29 pin of SlimSAS connector J1. Shunt installed across pins 2-3: PERST# signal routed to B30 pin of SlimSAS connector J1 (default).
J6	3x1 Header	Provision for connecting PERST# signal from the CEM connector to B11 or B12 pin of SlimSAS connector J2. Shunt installed across pins 1-2: PERST# signal routed to B11 pin of SlimSAS connector J2. Shunt installed across pins 2-3: PERST# signal routed to B12 pin of SlimSAS connector J2 (default).
J7	3x1 Header	Provision for connecting PERST# signal from the CEM connector to B29 or B30 pin of SlimSAS connector J2. Shunt installed across pins 1-2: PERST# signal routed to B29 pin of SlimSAS connector J2. Shunt installed across pins 2-3: PERST# signal routed to B30 pin of SlimSAS connector J2 (default).
J9	4x2 Header	Provision for connecting PRSNT1 signal to PRSNT2_1, PRSNT2_2, PRSNT2_3 and PRSNT2_4 pins on the CEM connector. Shunt installed across pins 1-2: PRSNT1 signal routed to PRSNT2_1 pin on the CEM connector (default). Shunt installed across pins 3-4: PRSNT1 signal routed to PRSNT2_2 pin on the CEM connector (default). Shunt installed across pins 5-6: PRSNT1 signal routed to PRSNT2_3 pin on the CEM connector (default). Shunt installed across pins 7-8: PRSNT1 signal routed to PRSNT2_4 pin on the CEM connector (default).
J16	4x1 Header	Access point to the pins A8, A9, A26, and A27 of SlimSAS connector J1.
J17	4x1 Header	Access point to the pins A8, A9, A26, and A27 of SlimSAS connector J2.
J21	3x1 Header	Provision for connecting PRSNT2_2 pin on the CEM connector to B11 or B12 pin of SlimSAS connector J1.
J22	3x1 Header	Provision for connecting PRSNT2_1 pin on the CEM connector to B29 or B30 pin of SlimSAS connector J1.
J23	3x1 Header	Provision for connecting PRSNT2_4 pin on the CEM connector to B11 or B12 pin of SlimSAS connector J2.
J24	3x1 Header	Provision for connecting PRSNT2_3 pin on the CEM connector to B29 or B30 pin of SlimSAS connector J2.

Table 2 shows PCIe reference clock controls and access points.

**Table 3. PCIe Reference Clock Controls and Access Points**

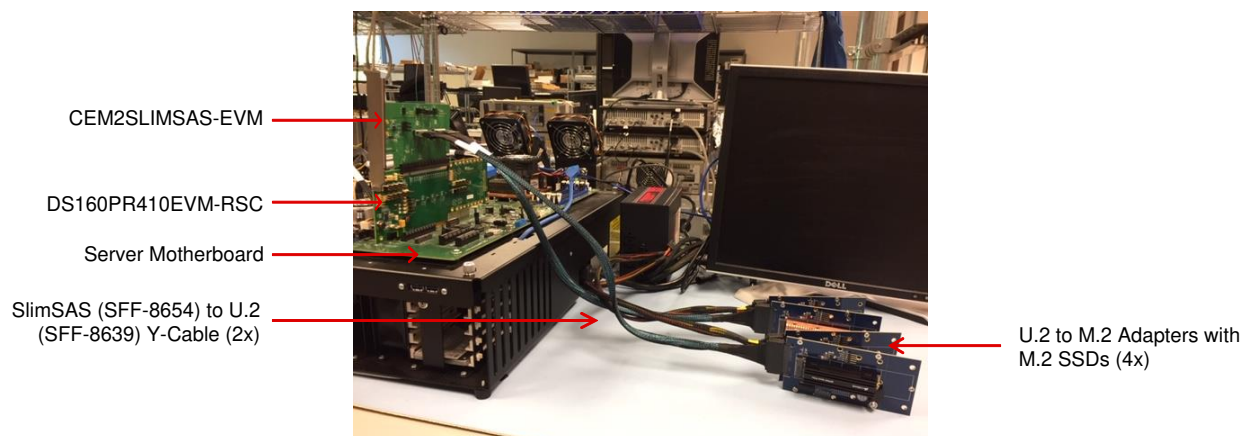
COMPONENT	NAME	FUNCTION / DESCRIPTION
J10	3x1 Header	Clock distributor (LMK00334) output enable Shunt installed across pins 1-2: outputs disabled. Shunt installed across pins 2-3: outputs enabled (default).
J11	3x1 Header	Clock distributor (LMK00334) input select Shunt installed across pins 1-2: CLKIN1 (An external clock source coming from the SMP connectors) selected. Shunt installed across pins 2-3: CLKIN0 (PCIe system clock coming from the CEM connector) selected (default).
J12 - J13	SMP Connectors	Provision for connecting an external clock source to the LMK00334 CLK1 input Plug into a PCIe x16 CEM slot.
J14	3x1 Header	Clock distributor (LMK00334) LVCMOS reference output enable Shunt installed across pins 1-2: reference output enabled. Shunt installed across pins 2-3: reference output disabled (default).
J15	2x1 Header	Access point to the LMK00334 reference output.

## 1.4 Quick-Start Guide

- Check that the shunts are at the following default positions as shown in [Figure 1](#).
  - J4: Shunt installed across pins 2-3: PERST# signal routed to B12 pin of SlimSAS connector J1.
  - J5: Shunt installed across pins 2-3: PERST# signal routed to B30 pin of SlimSAS connector J1.
  - J6: Shunt installed across pins 2-3: PERST# signal routed to B12 pin of SlimSAS connector J2.
  - J7: Shunt installed across pins 2-3: PERST# signal routed to B30 pin of SlimSAS connector J2.
  - J9: Shunts installed across pins 1-2, 3-4, 5-6, and 7-8: PRSNT1 signal routed to PRSNT2\_1, PRSNT2\_2, PRSNT2\_3, and PRSNT2\_4 pins on the CEM connector.
  - J10: Shunt installed across pins 2-3: LMK00334 outputs enabled.
  - J11: Shunt installed across pins 2-3: PCIe system clock selected as an input to the LMK00334.
  - J14: Shunt installed across pins 2-3: LMK00334 reference output disabled.
- Plug DS160PR410EVM-RSC, or other riser card style TI evaluation board into a PCIe x16 CEM slot on a motherboard. Ensure that the motherboard is powered down prior to installing the riser card.
- Install CEM2SLIMSAS-EVM into the straddle connector on the riser card selected in the prior step.
- Connect a SlimSAS (SFF-8654) to U.2 (SFF-8639) cable assembly (not included) into the SlimSAS connector J1 of the CEM2SLIMSAS-EVM. Alternatively, connect the second cable assembly into the SlimSAS connector J2 of the CEM2SLIMSAS-EVM.
- Attached an endpoint or endpoints on the other side of the cable. Ensure that the power is also provided to the endpoint(s) prior to powering up the motherboard.
- Power-up the motherboard.
- Observe a successful linkup of the endpoint(s) using system BIOS or other available system utility.

## 2 Typical Test Setup

[Figure 2](#) shows a typical system test setup with the DS160PR410EVM-RSC and CEM2SLIMSAS-EVM placed between a CPU on a server motherboard and PCIe 4.0 endpoints. The endpoints are SSDs with M.2 form factor mounted on U.2 to M.2 adapters.



**Figure 2. Example Test Setup**

The test setup features the following items not included in the CEM2SLIMSAS-EVM:

- SlimSAS x8 (SFF-8654) to 2x PCIe Drive Receptacle (SFF-8639) Cable (for U.2, 1x4 only), Part #: SLSP-8X-39X2F4-0.5M. More information about this item is available [here](#).
- PCIe 4.0 U.2 to M.2 Adapter, Part #: PCI-AD-U2M2-04-G4. More information about this item is available [here](#).

### 3 Board Layout

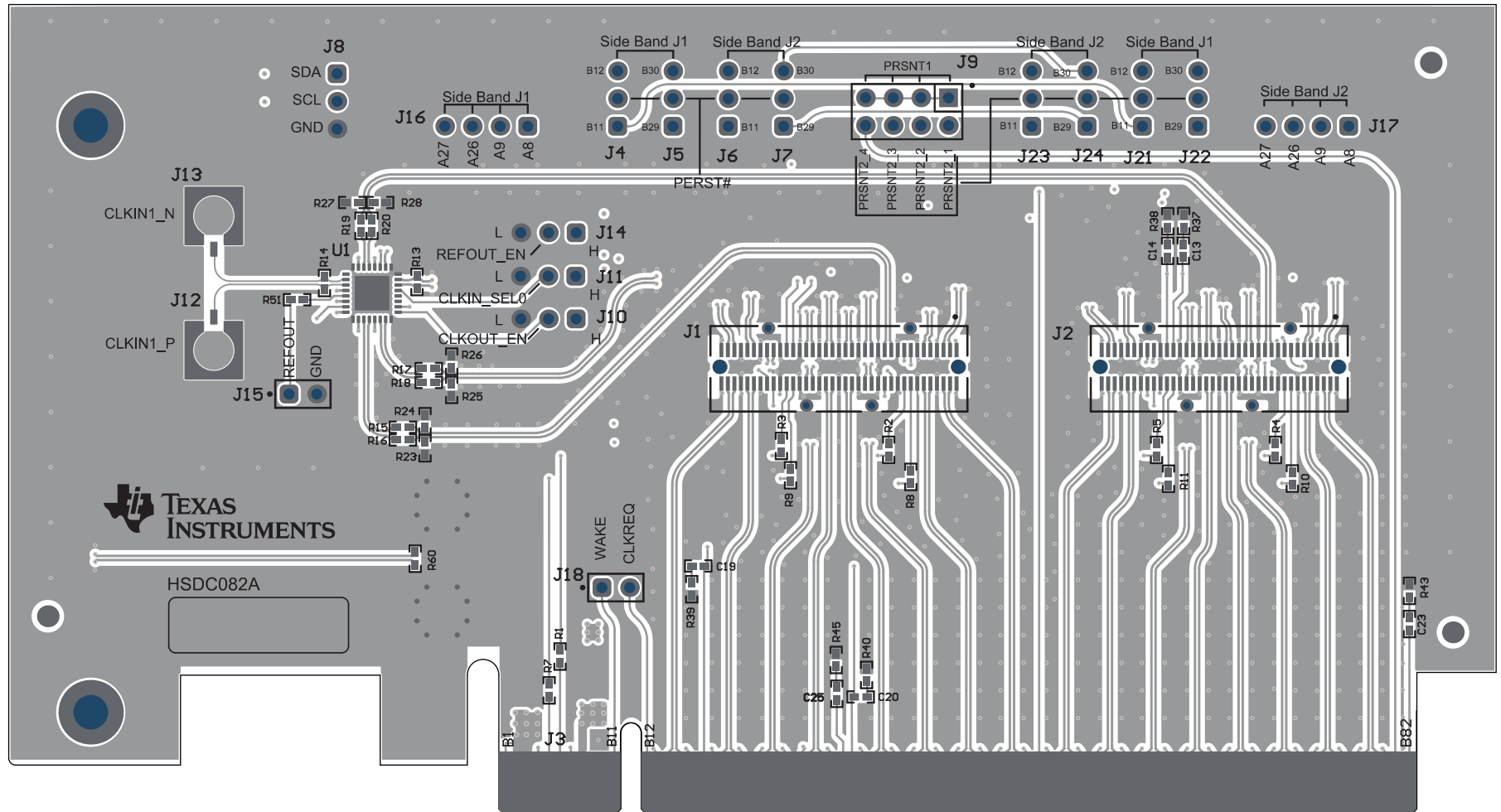
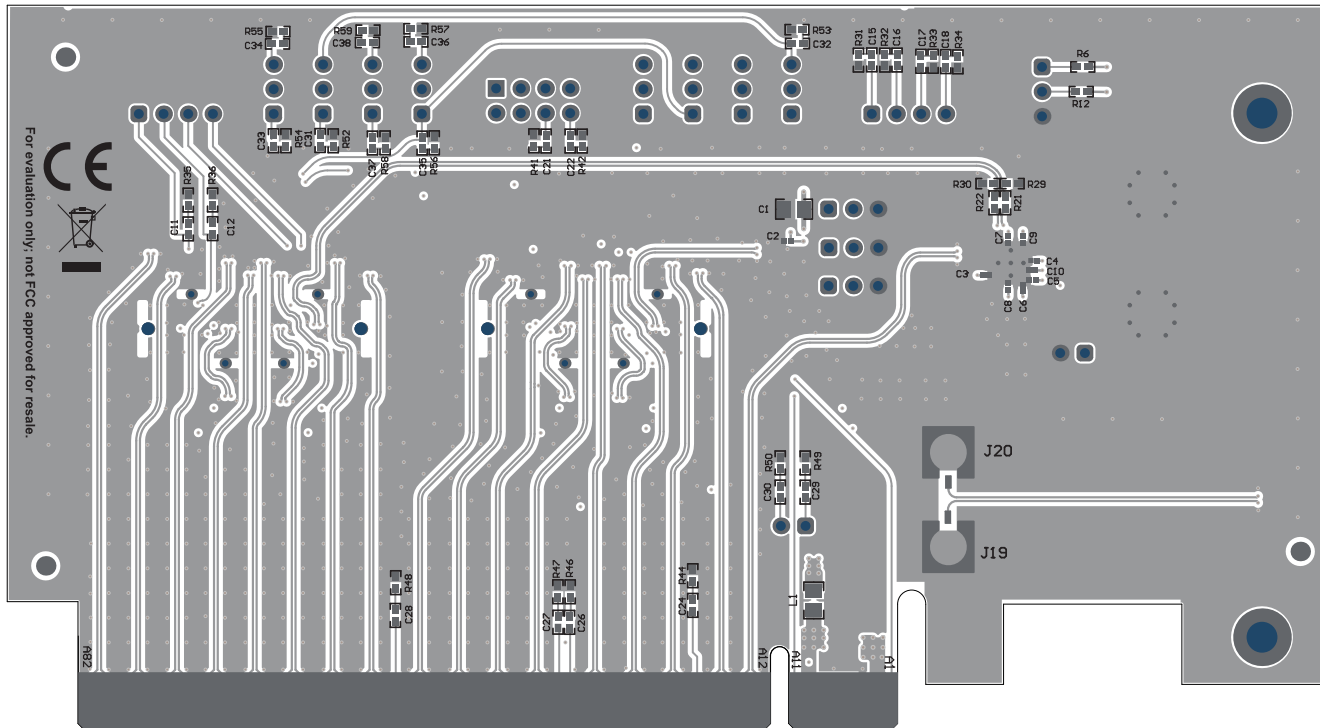


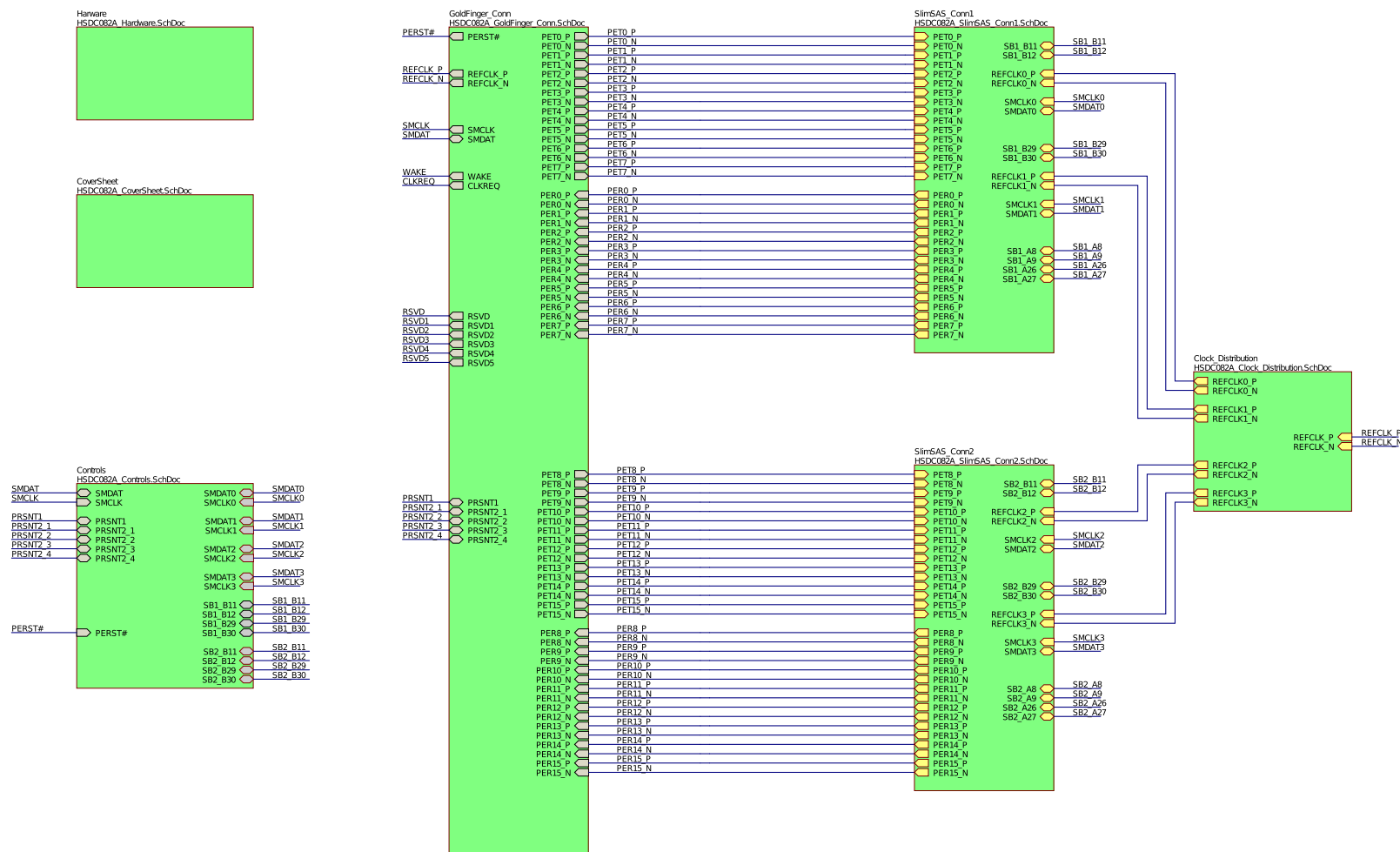
Figure 3. Top Layer



**Figure 4. Bottom Layer**

**4 Schematic and Bill of Materials**

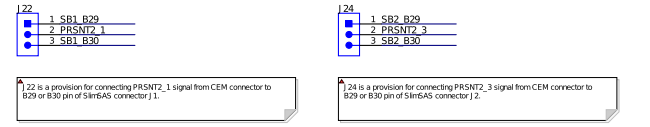
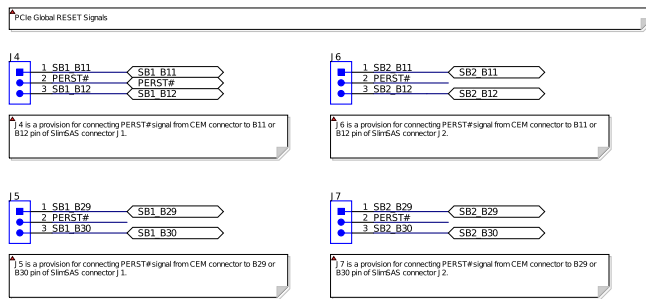
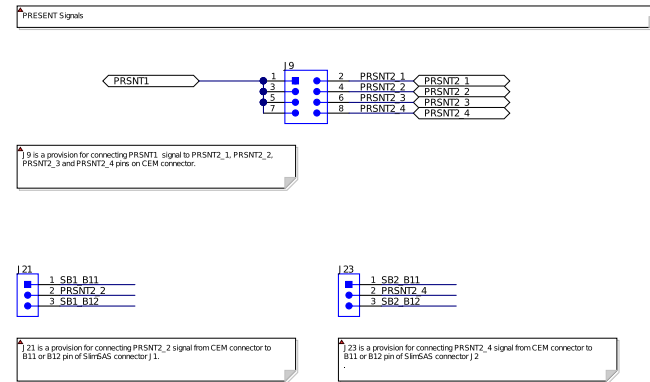
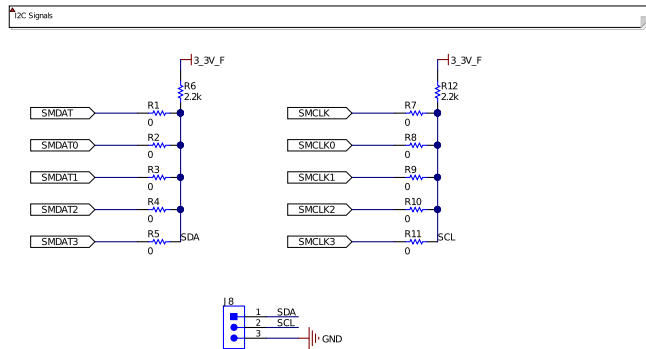
### 4.1 Schematic



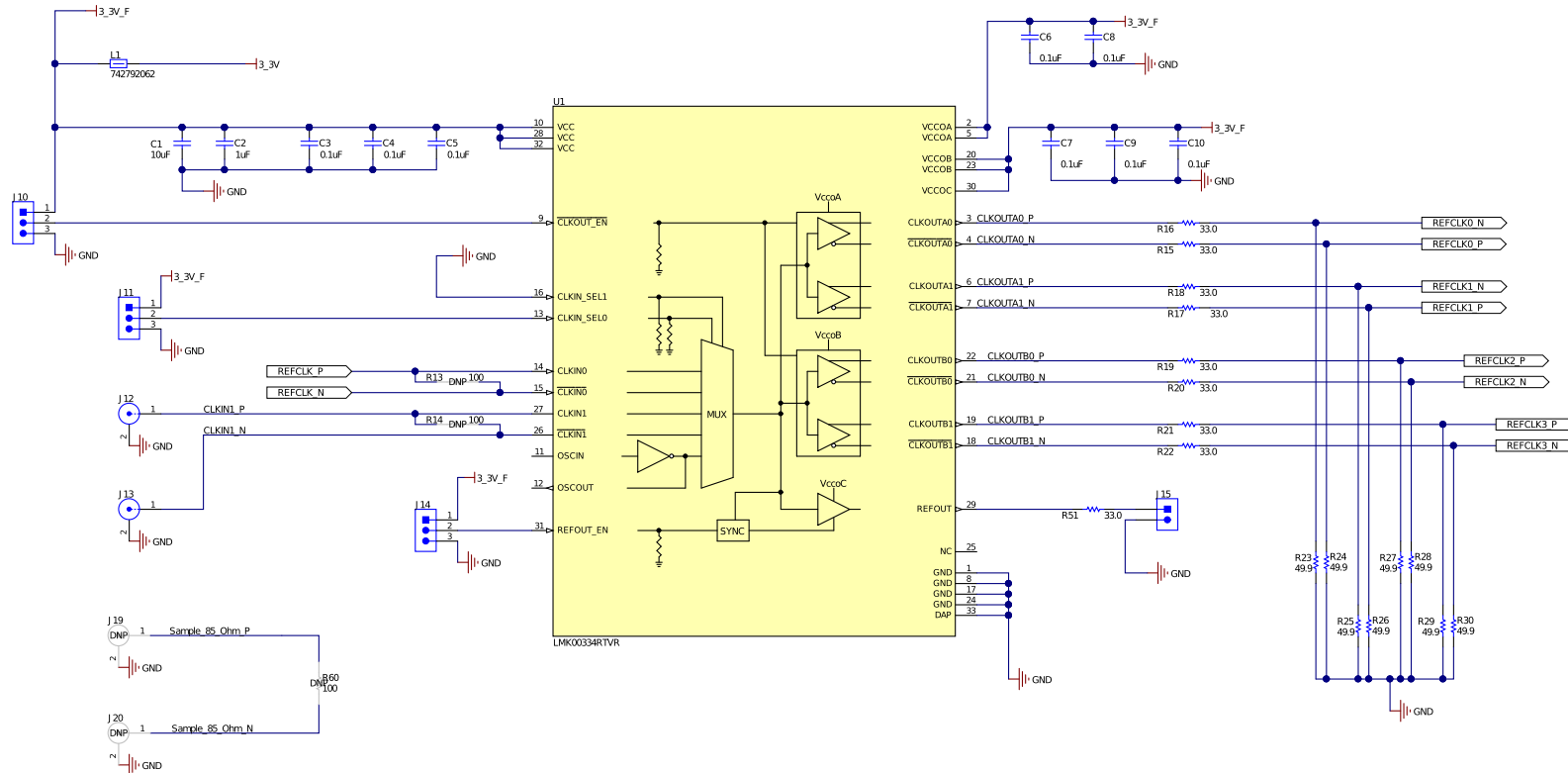
Copyright © 2020, Texas Instruments Incorporated

Figure 5. Top Level Schematic Page



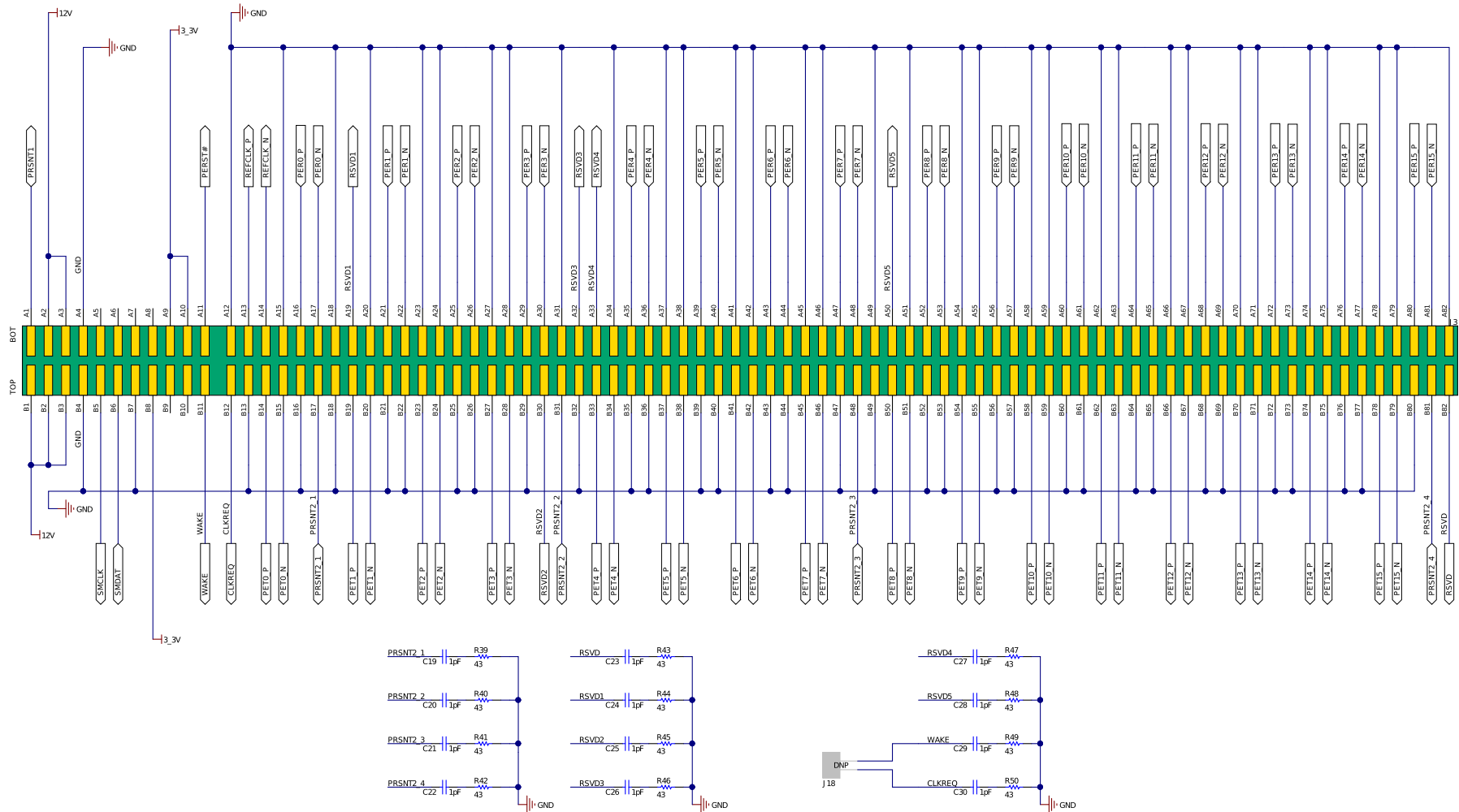


**Figure 6. Controls Schematic Page**



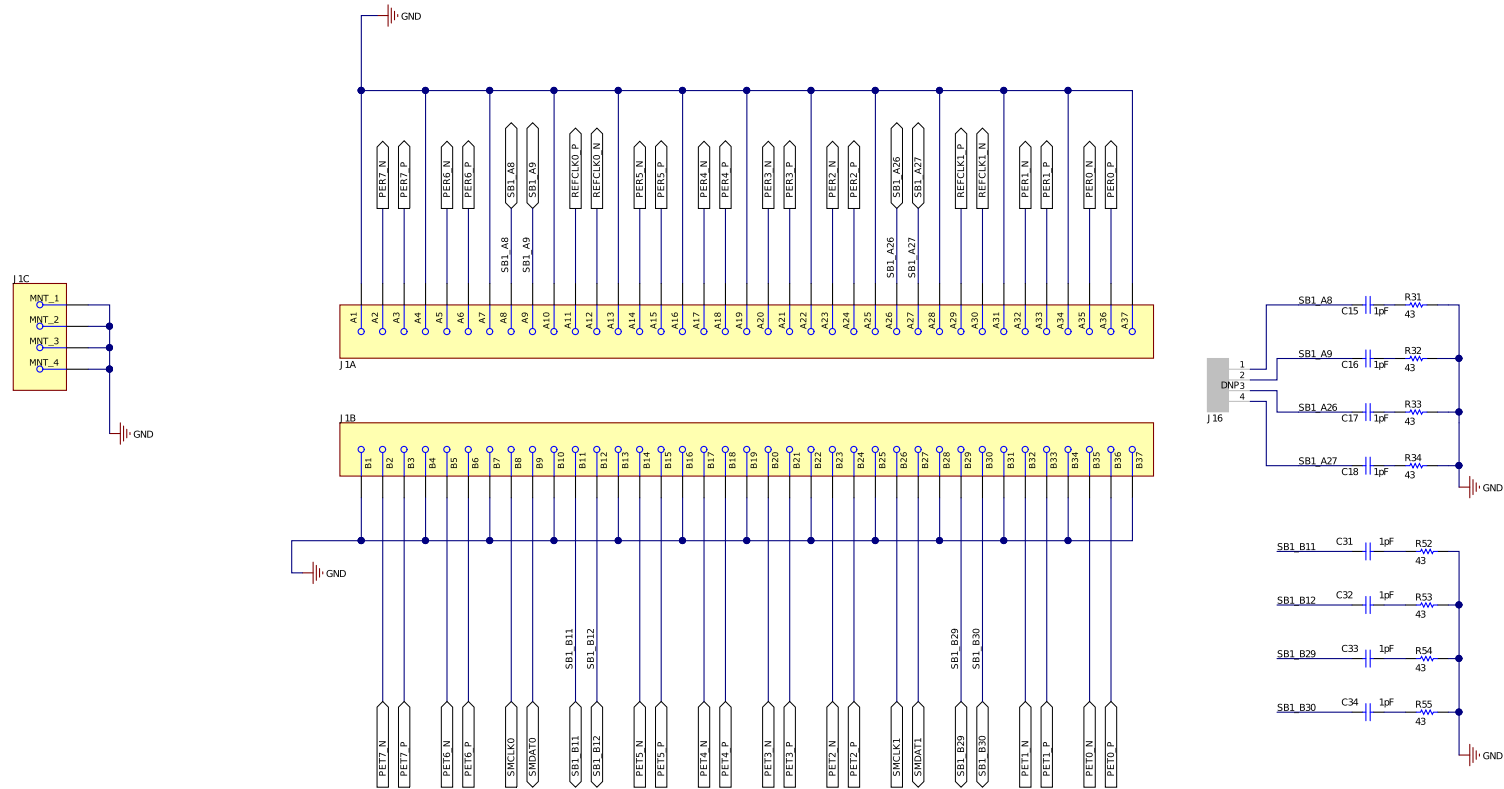
Copyright © 2020, Texas Instruments Incorporated

Figure 7. Clock Distribution Schematic Page



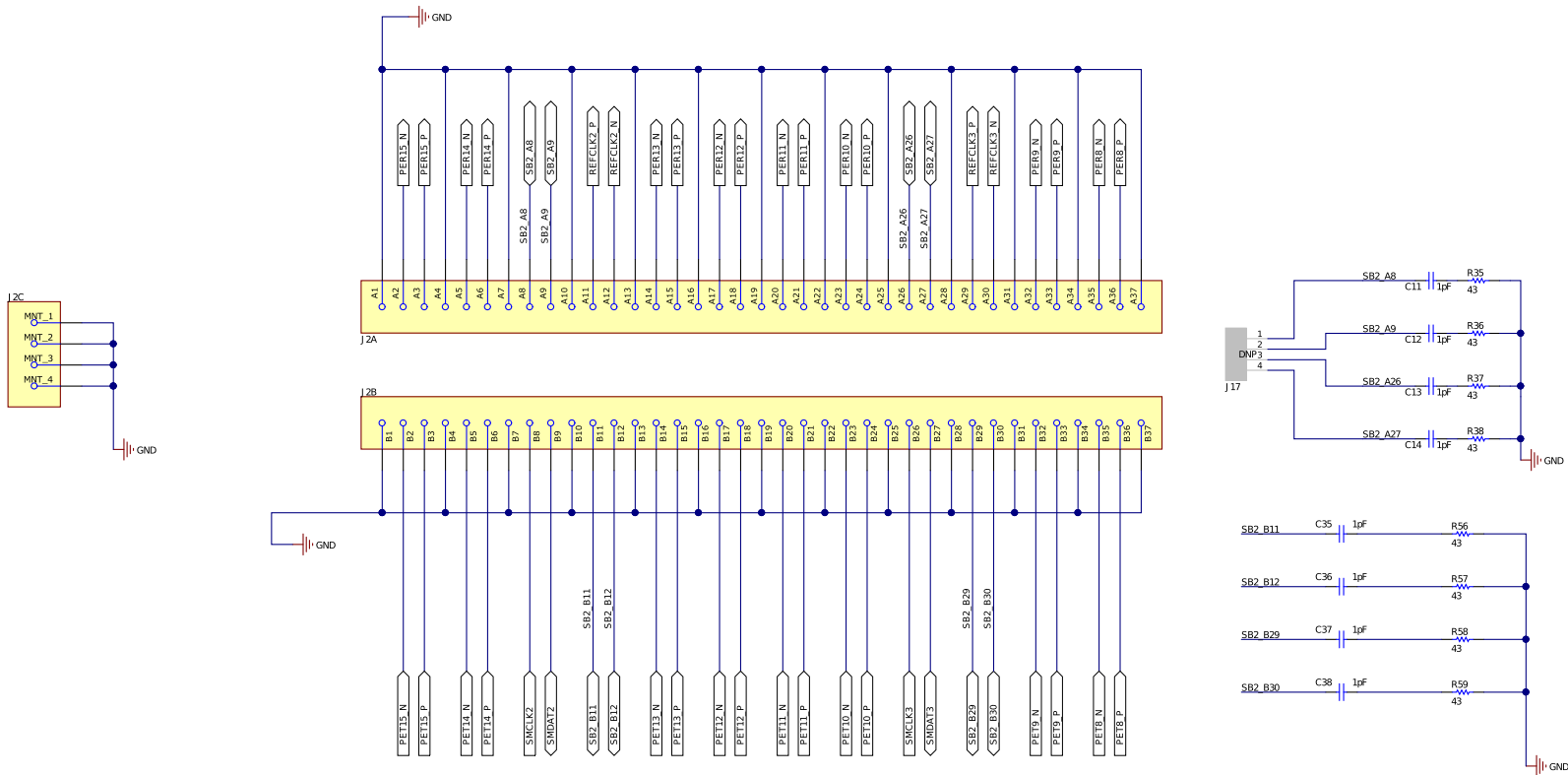
Copyright © 2020, Texas Instruments Incorporated

Figure 8. Goldfinger Connector Schematic Page



Copyright © 2020, Texas Instruments Incorporated

Figure 9. SlimSAS Connector 1 Schematic Page



Copyright © 2020, Texas Instruments Incorporated

Figure 10. SlimSAS Connector 2 Schematic Page

MP1

H1  
PMS55 440 0025 PH

H2  
PMS55 440 0025 PH

DNP FID1 DNP FID2 DNP FID3 DNP FID4 DNP FID5 DNP FID6

PCB Number: H5DC082  
PCB Rev: A

PCB LOGO  
Texas Instruments

CE Mark

PCB LOGO  
FCC disclaimer

PCB LOGO  
WEEE logo

SH1.1  
SH1.2  
SH1.3  
SH1.4  
SH1.5  
SH1.6  
SH1.7  
SH1.8  
SH1.9  
SH1.10  
SH1.11

LBL1  
PCB Label  
THT-14-423-10  
Size: 0.65" x 0.20"

ZZ1  
Label Assembly Note  
This Assembly Note is for PCB labels only

ZZ2  
Assembly Note  
These assemblies are ESD sensitive, ESD precautions shall be observed.

ZZ3  
Assembly Note  
These assemblies must be clean and free from flux and all contaminants. Use of no clean flux is not acceptable.

ZZ4  
Assembly Note  
These assemblies must comply with workmanship standards IPC-A-610 Class 2, unless otherwise specified.

ZZ5  
Assembly Note  
Refer to the test procedure for the correct placement of shunts.

Variant	Label Text
001	CEM2SLIMSAS-EVM

Copyright © 2020, Texas Instruments Incorporated

Figure 11. Hardware Page

## 4.2 Bill of Materials

**Table 4. Bill of Materials**

DESIGNATOR	QTY	VALUE	DESCRIPTION	PACKAGE REFERENCE	PART NUMBER	MANUFACTURER
!PCB1	1		Printed Circuit Board		HSDC082	Any
C1	1	10uF	CAP, CERM, 10 uF, 10 V, +/- 10%, X5R, 0805	0805	C0805C106K8PACTU	Kemet
C2	1	1uF	CAP, CERM, 1 uF, 6.3 V, +/- 20%, X5R, 0201	0201	GRM033R60J105MEA2D	MuRata
C3, C4, C5, C6, C7, C8, C9, C10	8	0.1uF	CAP, CERM, 0.1 uF, 6.3 V, +/- 10%, X5R, 0201	0201	GRM033R60J104KE19D	MuRata
C11, C12, C13, C14, C15, C16, C17, C18, C19, C20, C21, C22, C23, C24, C25, C26, C27, C28, C29, C30, C31, C32, C33, C34, C35, C36, C37, C38	28	1pF	CAP, CERM, 1 pF, 50 V, +/- 10%, COG/NP0, 0402	0402	GJM1555C1H1R0BB01D	MuRata
H1, H2	2		MACHINE SCREW PAN PHILLIPS 4-40	Machine Screw, 4-40, 1/4 inch	PMSSS 440 0025 PH	B and F Fastener Supply
J1, J2	2		CONN MINISAS RCTP SLDR SMD	HDR74	U10-B074-200T	Amphenol
J4, J5, J6, J7, J8, J10, J11, J14, J21, J22, J23, J24	12		Header, 100mil, 3x1, Gold, TH	3x1 Header	TSW-103-07-G-S	Samtec
J9	1		Header, 100mil, 4x2, Gold, TH	4x2 Header	TSW-104-07-G-D	Samtec
J12, J13	2		Plug, 50 Ohm, Straight, SMT	SMA Plug, Straight, SMT	0853050232	Molex
J15	1		Header, 100mil, 2x1, Gold, TH	2x1 Header	TSW-102-07-G-S	Samtec
L1	1	80 ohm	Ferrite Bead, 80 ohm @ 100 MHz, 0.5 A, 0805	0805	742792062	Würth Elektronik
LBL1	1		Thermal Transfer Printable Labels, 0.650" W x 0.200" H - 10,000 per roll	PCB Label 0.650 x 0.200 inch	THT-14-423-10	Brady
MP1	1		PCI bracket	PCI_BRCKT_NPTH_2	9B90-0000A	Gompf Brackets, Inc.
R1, R2, R3, R4, R5, R7, R8, R9, R10, R11	10	0	RES, 0, 5%, 0.1 W, AEC-Q200 Grade 0, 0402	0402	ERJ-2GE0R00X	Panasonic

**Table 4. Bill of Materials (continued)**

DESIGNATOR	QTY	VALUE	DESCRIPTION	PACKAGE REFERENCE	PART NUMBER	MANUFACTURER
R6, R12	2	2.2k	RES, 2.2 k, 5%, 0.063 W, AEC-Q200 Grade 0, 0402	0402	CRCW04022K20JNED	Vishay-Dale
R15, R16, R17, R18, R19, R20, R21, R22, R51	9	33.0	RES, 33.0, 1%, 0.062 W, 0402	0402	RC0402FR-0733RL	Yageo America
R23, R24, R25, R26, R27, R28, R29, R30	8	49.9	RES, 49.9, 1%, 0.063 W, 0402	0402	RC0402FR-0749R9L	Yageo America
R31, R32, R33, R34, R35, R36, R37, R38, R39, R40, R41, R42, R43, R44, R45, R46, R47, R48, R49, R50, R52, R53, R54, R55, R56, R57, R58, R59	28	43	RES, 43, 5%, 0.063 W, AEC-Q200 Grade 0, 0402	0402	CRCW040243R0JNED	Vishay-Dale
SH-J1, SH-J2, SH-J3, SH-J4, SH-J5, SH-J6, SH-J7, SH-J8, SH-J9, SH-J10, SH-J11	11	1x2	Shunt, 100mil, Flash Gold, Black	Closed Top 100mil Shunt	SPC02SYAN	Sullins Connector Solutions
U1	1		LMK00334 4-Output PCIe Gen1/Gen2/Gen3/Gen4 Clock Buffer/Level Translator, RTV0032A (WQFN-32)	RTV0032A	LMK00334RTVR	Texas Instruments
FID1, FID2, FID3, FID4, FID5, FID6	0		Fiducial mark. There is nothing to buy or mount.	N/A	N/A	N/A
J16, J17	0		Header, 100mil, 4x1, Gold, TH	4x1 Header	TSW-104-07-G-S	Samtec
J18	0		Header, 100mil, 2x1, Gold, TH	2x1 Header	TSW-102-07-G-S	Samtec
J19, J20	0		Plug, 50 Ohm, Straight, SMT	SMP Plug, Straight, SMT	0853050232	Molex
R13, R14, R60	0	100	RES, 100, 1%, 0.063 W, AEC-Q200 Grade 0, 0402	0402	CRCW0402100RFKED	Vishay-Dale





## 5 References

For references, see the following:

1. Texas Instruments, [DS160PR410 Quad-Channel PCI-Express 4.0 Linear Redriver Datasheet](#) (SNLS645)
2. Texas Instruments, [LMK00334 Four-Output PCIe/Gen1/Gen2/Gen3/Gen4 Clock Buffer and Level Translator Datasheet](#) (SNAS635)
3. Texas Instruments, [DS160PR410EVM-RSC Evaluation Module User's Guide](#) (SNLU252)

## IMPORTANT NOTICE AND DISCLAIMER

TI PROVIDES TECHNICAL AND RELIABILITY DATA (INCLUDING DATASHEETS), DESIGN RESOURCES (INCLUDING REFERENCE DESIGNS), APPLICATION OR OTHER DESIGN ADVICE, WEB TOOLS, SAFETY INFORMATION, AND OTHER RESOURCES "AS IS" AND WITH ALL FAULTS, AND DISCLAIMS ALL WARRANTIES, EXPRESS AND IMPLIED, INCLUDING WITHOUT LIMITATION ANY IMPLIED WARRANTIES OF MERCHANTABILITY, FITNESS FOR A PARTICULAR PURPOSE OR NON-INFRINGEMENT OF THIRD PARTY INTELLECTUAL PROPERTY RIGHTS.

These resources are intended for skilled developers designing with TI products. You are solely responsible for (1) selecting the appropriate TI products for your application, (2) designing, validating and testing your application, and (3) ensuring your application meets applicable standards, and any other safety, security, or other requirements. These resources are subject to change without notice. TI grants you permission to use these resources only for development of an application that uses the TI products described in the resource. Other reproduction and display of these resources is prohibited. No license is granted to any other TI intellectual property right or to any third party intellectual property right. TI disclaims responsibility for, and you will fully indemnify TI and its representatives against, any claims, damages, costs, losses, and liabilities arising out of your use of these resources.

TI's products are provided subject to TI's Terms of Sale ([www.ti.com/legal/termsofsale.html](http://www.ti.com/legal/termsofsale.html)) or other applicable terms available either on [ti.com](http://ti.com) or provided in conjunction with such TI products. TI's provision of these resources does not expand or otherwise alter TI's applicable warranties or warranty disclaimers for TI products.

Mailing Address: Texas Instruments, Post Office Box 655303, Dallas, Texas 75265  
Copyright © 2020, Texas Instruments Incorporated