



Test Procedure for the STK681-332GEVB Evaluation Board

Evaluation Board Setup

[Supply Voltage] Vcc (10 to 38V: STK681-332-E): Power Supply for stepping motor
 Vcc (10 to 29V: STK681-352-E): Power Supply for stepping motor

 Vref (0 to 2.0V): Const. Current Control for Reference Voltage
 VDD (5V) : Power Supply for internal logic IC

[Operation Guide]

1. Motor Connection:
 Connect the motor to OUT1 and OUT2.
2. Initial Condition Setting:
 Set to signal condition IN1=H, IN2=H, and ENABLE=L.
3. Power Supply:
 <STK681-332-E>
 At first, supply DC voltage to VDD (5.0V), and VREF.
 Next, supply DC voltage to Vcc.
 <STK681-352-E>
 At first, supply DC voltage to VDD (3.3V or 5.0V), and VREF.
 Next, supply DC voltage to Vcc.
4. Set to Forward or Reverse signal condition with ENABLE=Low.
 Turn "High" ENABLE signal.
 Output current flows between OUT1 and OUT2.
5. Motor Operation

[Setting the current limit using the Vref pin]

Output current peak (Iop) = (Vref÷4.9) ÷Rs

"4.9" in the above formula indicates the portion of the Vref voltage that is divided using the circuit inside the control IC.

$V_{ref} = (R_2 \div (R_1 + R_2)) \times 5.0V$ (or 3.3V)

Rs is the external current detection resistance value of the HIC, and $V_{ref} \leq 2.0V$ must be satisfied so that overcurrent detection is not triggered.



Allowable power dissipation (Reference value)

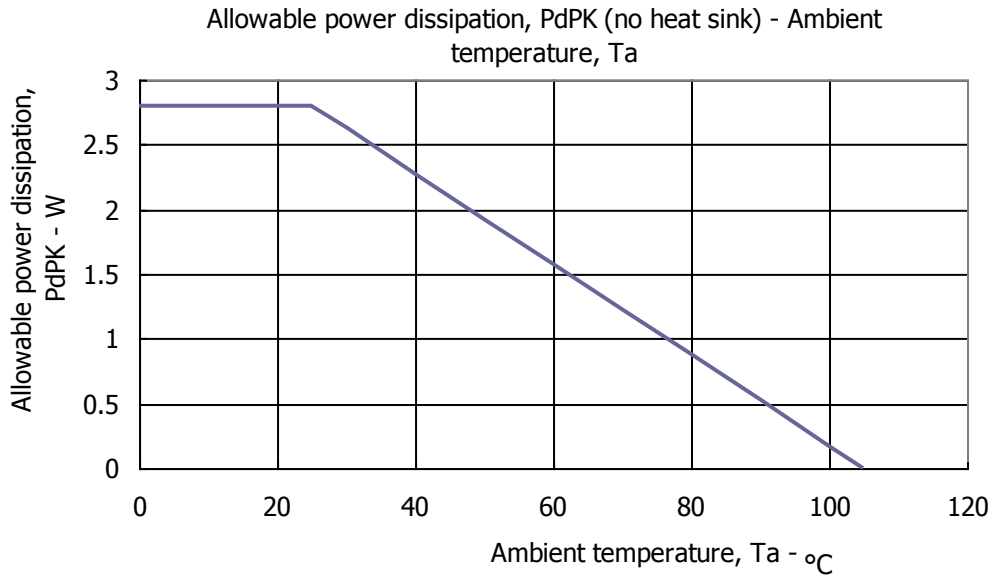

If you need heat sink to STK681-332 and 352, mount heat sink with something such as clips.

Waveform example

STK681-332 (Current limit 5A setting)
 IN1 and IN2; 5V/div, Output current; 5A/div

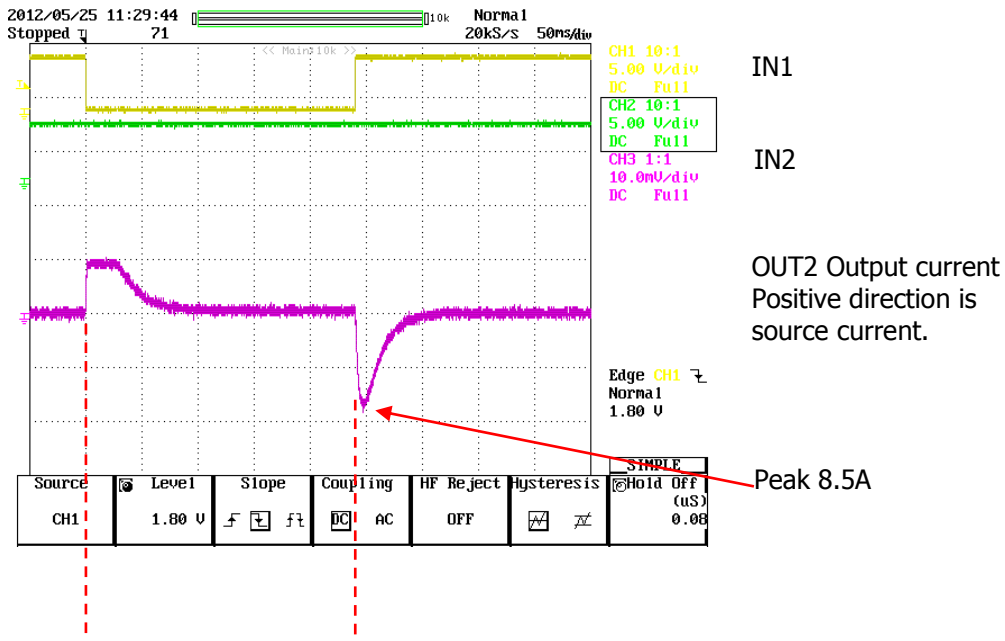



STK681-332 (Current limit 5A setting)
 IN1 5V/div, OUT2 20V/div, Output current; 5A/div

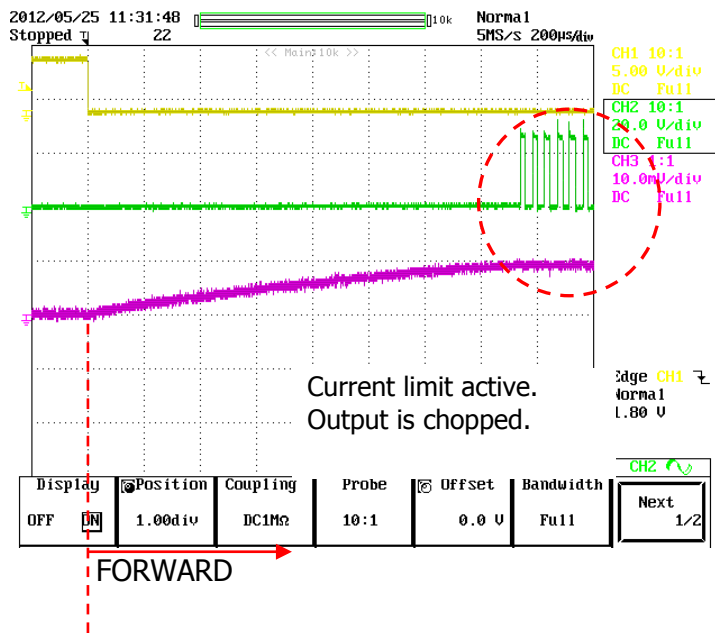

IN1

OUT2

OUT2 Output current
 Positive direction is source current.

Current control is slow decay.
 STK681-332 and 352 control MOSFET at Low side by constant-current PWM control system.
 Current control enters Slow decay mode.

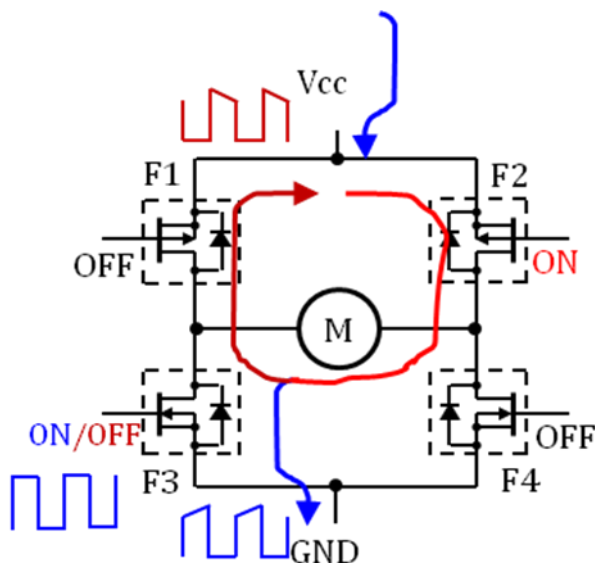



STK681-332 and 352 have ENABLE terminal built-in, which controls motor rotation.
 At the point of ENABLE=High, F3 or F4 at Low side turns on.
 STK681-332, 352(ENABLE: 20kHz)
 ENABLE ; 5V/div, OUT1 ; 20V/div, Output current; 0.5A/div

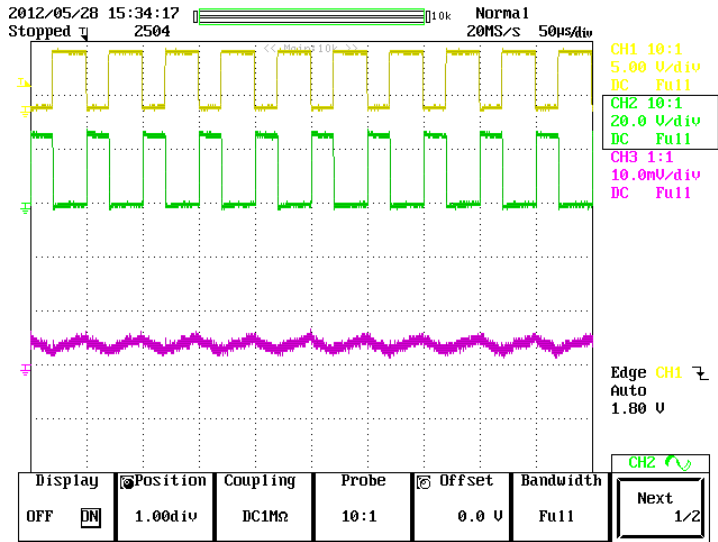

ENABLE High duty 60%

OUT1

Output current