

Getting started with the X-NUCLEO-USBPDM1 USB Type-C™ Power Delivery Sink expansion board based on TCPP01-M12 for STM32 Nucleo

Introduction

The X-NUCLEO-USBPDM1 is an expansion board for the NUCLEO-G071RB and NUCLEO-G474RE development boards or any STM32 Nucleo development board equipped with a USB Type-C peripheral.

The X-NUCLEO-USBPDM1 is compliant with USB Type-C Rev 1.2 and Power Delivery 3.0 with 100 W PPS support, as well as USB-IF certified (Test ID certification: 3036).

It provides a straightforward means for evaluating USB Type-C Power Delivery in Sink mode based on TCPP01-M12.

The USB Type-C connector can supply the STM32 Nucleo development board thanks to a 3.3 V LDO.

Figure 1. X-NUCLEO-USBPDM1 expansion board

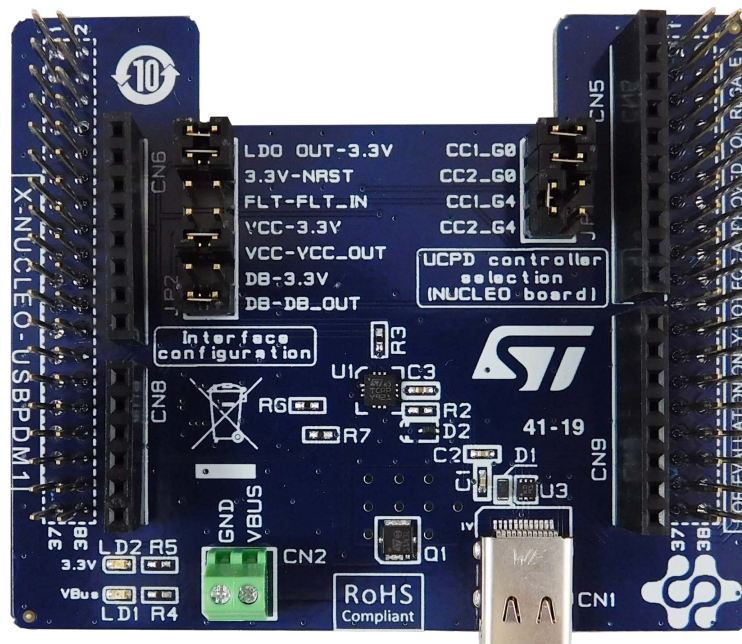

1 Getting started

1.1 Overview

The X-NUCLEO-USBPDM1 expansion board features:

- 100 W programmable power supply (PPS) support
- USB Type-C reversible connector
- 6 V overvoltage protection (OVP) on CC lines against short-to- V_{BUS} when the connector is unplugged
- Up to 22 V adjustable overvoltage protection (OVP) on V_{BUS} line against charger failure
- Surge protection and system-level ESD protection on V_{BUS}
- Common-mode filter and ESD protection on USB 2.0 High Speed data-lines
- System-level ESD protection on CC lines as per IEC61000-4-2 level 4 (± 8 kV contact discharge)
- Low power mode for battery operation allows zero current consumption when no cable is attached
- Integrated dead battery management for fully depleted battery devices
- Overtemperature protection (OTP)
- Compliant with USB Type-C Rev 1.2 and Power Delivery 3.0 standards
- USB-IF certified (Test ID certification: 3036)

1.2 Hardware requirements

The X-NUCLEO-USBPDM1 expansion board is designed to be used with any **STM32 Nucleo** development board equipped with a UCPD peripheral (for example, NUCLEO-G01xxxx or NUCLEO-G41xxxx), although complete testing has only been performed using **NUCLEO-G071RB** and **NUCLEO-G474RE** development boards hosting the **STM32G071RB** and **STM32G474RE** microcontrollers, respectively.

The expansion board must be plugged on the matching pins of the development board connector.

Figure 2. X-NUCLEO-USBPDM1 plugged on an STM32 Nucleo board

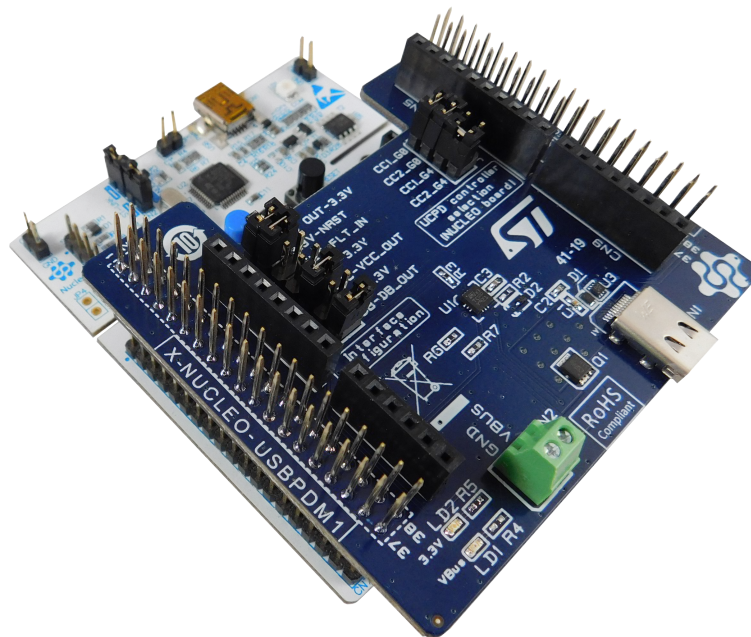

1.3 Software requirements

- All-in-one multi-OS software tool for programming STM32 products ([STM32CubeProg](#))
- [ST-LINK/V2-1](#) USB driver
- Binary files with specific use-cases ([X-CUBE-USBPDM1](#))

2 Board component description and configuration

2.1 Connectors

The **X-NUCLEO-USBPDM1** expansion board is equipped with USB Type-C™ connector (CN1).

V_{BUS} can supply:

- the power connector (CN2) in normal mode
- STM32 when LDO (U2) output is connected to 3.3 V pin

2.2 Jumpers

To select the **STM32 Nucleo** development board to be used with the **X-NUCLEO-USBPDM1** expansion board, use JP1 jumper (UCPD peripheral selection) and CC lines (CC1 and CC2) connection:

- For the **NUCLEO-G071RB** development board, use STM32 UCPD transceiver CC lines connection to ST morpho connector (CN10–23 and CN10–26).
- For the **NUCLEO-G474RE** development board, use STM32 UCPD transceiver CC lines connection to ST morpho connector (CN10–17 and CN10–27).

Other connections among the two boards are configured by JP2 jumpers.

The global jumper setup is the following:

- **LDO OUT – 3.3 V** to connect the LDO output to 3.3 V on the **X-NUCLEO-USBPDM1**. The STM32 is powered by the USB Type-C connector.

Note: *In this mode, the only way to program the **STM32 Nucleo** development board is to power the ST-LINK and disconnect the LDO output.*

- **3.3 V** is common between **X-NUCLEO-USBPDM1** and **STM32 Nucleo** development boards.
- **3.3 V – NRST** to force the STM32 I/O negative reset to level '1'. It must be connected when the STM32 is powered by the **X-NUCLEO-USBPDM1** and when the **STM32 Nucleo** development board ST-LINK is connected. When programming or when ST-LINK is physically disconnected from the **STM32 Nucleo** development board, **3.3 V – NRST** must be disconnected.
- **FLT – FLT_IN** to connect the **TCP01-M12** fault report (open drain) to a pull-up output and to the ST morpho connector (CN10 – 18, PC0 of **NUCLEO-G071RB** and PB11 of **NUCLEO-G474RE**).

The **TCP01-M12** supply options are:

- **VCC – 3.3V** to supply the **TCP01-M12** V_{CC} with 3.3 V.
- **VCC – VCC_OUT** to supply the **TCP01-M12** V_{CC} via a GPIO on ST morpho connector (CN7 – 1, PC10 of **NUCLEO-G071RB** and **NUCLEO-G474RE**). This case is useful with battery powered devices as the **TCP01-M12** can be powered only when an attachment is detected (low power mode).
- Integrated dead battery management for fully depleted battery devices.

Dead battery management options are:

- **DB – 3.3 V** to remove the **TCP01-M12** dead battery clamp when 3.3 V is present.
- **DB – DB_OUT** to remove the **TCP01-M12** dead battery clamp when GPIO is connected on ST morpho connector CN10 – 24. In this case, the STM32 MCU manages dead battery clamp removal.

2.3 LEDs

Two LEDs are mounted on the **X-NUCLEO-USBPDM1** expansion board top side:

- A red LED to indicate the USB Type-C V_{BUS} voltage is present (voltage on CN2 and LDO powered).
- A green LED to indicate that 3.3 V is present and can be supplied by the **STM32 Nucleo** development board or by the **X-NUCLEO-USBPDM1** LDO.

2.4 V_{BUS} overvoltage protection setup

On the **X-NUCLEO-USBPDM1** expansion board bottom side, a zero Ohm resistor (R0) selects a 22 V OVP threshold.

To change the threshold to another value (6 V, 10 V, 13 V or 17 V), R0 must be removed and a solder bridge must be added on the selected OVP voltage.

2.5 USB Type-C D+/D- connections

On the [X-NUCLEO-USBPDM1](#) expansion board bottom side, D+/D- lines from USB Type-C CN1 are connected to D+/D- lines of the [NUCLEO-G474RE](#) development board thanks to R8 and R9 zero Ohm resistors. These lines can be used for USB BC 1.2 check and data transmission.

There is no USB data on the [NUCLEO-G071RB](#) but USB BC 1.2 check can be done thanks to [STM32G071RB](#) PA4 (CN7 – 32) and PA5 (CN10 – 11): zero Ohm resistors R8 and R9 must be unsoldered and zero Ohm resistors must be soldered on R10 and R11 footprints.

3 Programming and debugging

For programming and debugging, the [X-NUCLEO-USBPDM1](#) expansion board must be powered by the [STM32 Nucleo](#) development board.

JP2 **LDO OUT – 3.3 V** and **3.3 V – NRST** pins must be removed.

TCPP01-M12 can be powered by one of the following options:

- the [STM32 Nucleo](#) 3.3 V (JP2 **Vcc – 3.3 V** jumper close and **VCC – V_OUT** jumper open)
- a dedicated STM32 GPIO for battery powered cases (JP2 **VCC – 3.3V** jumper open and **VCC – V_OUT** jumper closed). This case is also called low power mode.

TCPP01-M12 dead battery resistor clamps are removed:

- automatically when 3.3 V is present (JP2 **DB – 3.3 V** jumper closed and **DB – DB_OUT** open)
- or by a GPIO (JP2 **DB – 3.3 V** jumper open and **DB – DB_OUT** closed)

4 USB Type-C powered mode

Once STM32 is programmed, it is possible to power the STM32 using USB Type-C V_{BUS} voltage through a source device connected to the Type-C connector (CN1). The X-NUCLEO-USBPDM1 on-board LDO (U2) generates 3.3 V to supply the system. In this case, 5 V is not available yet on the STM32 Nucleo development board.

Note: STM32 Nucleo development board power jumper must not be connected (JP2 of NUCLEO-G071RB or JP5 of NUCLEO-G474RE).

JP2 LDO OUT-3.3 V and 3.3 V-NRST jumpers must be closed.

TCPPO1-M12 can be powered by:

- 3.3 V from the USB Type-C connector V_{BUS} (JP2 Vcc – 3.3 V jumper closed and Vcc-V_OUT jumper open) or
- a dedicated STM32 GPIO for battery powered cases (JP2 Vcc – 3.3 V jumper open and Vcc-V_OUT jumper closed). This case is also called low power mode.

TCPPO1-M12 dead battery resistor clamps are removed:

- automatically when 3.3 V is present (JP2 DB – 3.3 V jumper closed and DB – DB_OUT open) or
- by GPIO (JP2 DB – 3.3 V jumper open and DB – DB_OUT closed).

5 NUCLEO-G474RE Type-C powered mode Sink contract negotiation

In this case, dead battery clamps are removed when 3.3 V jumper is connected (not in low power mode). NUCLEO-G474RE must be powered by ST-LINK micro-USB connector (JP5 **5V_STLK** jumper closed).

- Step 1.** Connect the NUCLEO-G474RE micro-USB connector (CN1) to your PC. NUCLEO-G474RE appears as a virtual disk (NODE_G474RB).
- Step 2.** To program the STM32G474RE, drag and drop the binary file corresponding to the required voltage (G474RE_TCPP01_no-low-power_no-DB-mng_SNK_xxV_v1.bin, xx is the selected voltage) to the virtual disk.
LD1 blinks red and green for few seconds. When it does not blink any more, programming is complete.
- Step 3.** Plug the X-NUCLEO-USBPDM1 expansion board on top of the NUCLEO-G474RE development board.
- Step 4.** On X-NUCLEO-USBPDM1 JP1, close **CC1_G4** and **CC2_G4**, and leave the other jumpers open.
- Step 5.** On X-NUCLEO-USBPDM1 JP2, close **Vcc-3.3 V** and **DB-3.3V** and leave the other jumpers open. X-NUCLEO-USBPDM1 CN1 (USB Type-C receptacle) can be connected to any Type-C source. The X-CUBE-USBPDM1 selects the highest and closest power profile to the value indicated by the binary file from available power profiles on the source. The obtained voltage can be measured on X-NUCLEO-USBPDM1 CN2.
- Step 6.** Disconnect the micro-USB cable from NUCLEO-G474RE CN1 and the USB Type-C cable from X-NUCLEO-USBPDM1 CN1.
- Step 7.** Remove the power supply from NUCLEO-G474RE (JP5 fully open).
- Step 8.** On X-NUCLEO-USBPDM1 JP2, close **LDO OUT 3.3 V**, **3.3 V-NRST**, **Vcc-3.3 V** and **DB - 3.3 V** and leave the other jumpers open.

As previously mentioned, X-NUCLEO-USBPDM1 CN1 (USB Type-C receptacle) can be connected to any Type-C source. The X-CUBE-USBPDM1 selects the highest and closest power profile to the value indicated by the binary file from available power profiles on the source. STM32G474RE is then powered by Type-C connector and X-NUCLEO-USBPDM1 can be fine tuned with V_{BUS} OVP voltage selection thanks to R0 position change. This configuration is relevant for a Type-C powered device without battery as it is not in low power mode (Vcc is directly connected to 3.3 V). The data lines of Type-C connector CN1 are connected to the STM32G474RE USB 2.0 full-speed transceiver thanks to R8 and R9 zero Ohm resistors.

6 NUCLEO-G071RB Type-C powered mode Sink contract negotiation

In this case, dead battery clamps are managed by [STM32G071RB](#) in low power mode.

[NUCLEO-071RB](#) must be powered by ST-LINK micro-USB connector (JP2 **STLK** jumper closed).

- Step 1.** Connect the [NUCLEO-071RB](#) micro-USB connector (CN1) to your PC.
[NUCLEO-071RB](#) appears as a virtual disk (NODE_G071RB).
- Step 2.** To program the [STM32G071RB](#), drag and drop the binary file corresponding to the required voltage ([G071RB_TCPP01_low-power_no-DB-mng_SNK_xxV_v1.bin](#), **xx** is the selected voltage) to the virtual disk.
LD1 blinks red and green for few seconds. When it does not blink anymore, programming is complete.
- Step 3.** Plug the [X-NUCLEO-USBPDM1](#) expansion board on top of the [NUCLEO-071RB](#) development board.
- Step 4.** On [X-NUCLEO-USBPDM1](#) JP1, close **CC1_G0** and **CC2_G0**, and leave the other jumpers open.
- Step 5.** On [X-NUCLEO-USBPDM1](#) JP2, close **Vcc-Vcc_OUT** and **DB-DB_OUT** and leave the other jumpers open.
[X-NUCLEO-USBPDM1](#) CN1 (USB Type-C receptacle) can be connected to any Type-C source. The [X-CUBE-USBPDM1](#) selects the highest and closest power profile to the value indicated by the binary file from available power profiles on the source. The obtained voltage can be measured on [X-NUCLEO-USBPDM1](#) CN2.
- Step 6.** Disconnect the micro-USB cable from [NUCLEO-071RB](#) CN1 and the USB Type-C cable from [X-NUCLEO-USBPDM1](#) CN1.
- Step 7.** Remove the power supply from [NUCLEO-071RB](#) (JP2 fully open).
- Step 8.** On [X-NUCLEO-USBPDM1](#) JP2, close **LDO OUT 3.3 V**, **3.3 V-NRST**, **Vcc-Vcc_OUT** and **DB-DB_OUT** and leave the other jumpers open.
As previously mentioned, [X-NUCLEO-USBPDM1](#) CN1 (USB Type-C receptacle) can be connected to any Type-C source. The [X-CUBE-USBPDM1](#) selects the highest and closest power profile to the value indicated by the binary file from available power profiles on the source. [STM32G474RE](#) is then powered by Type-C connector and [X-NUCLEO-USBPDM1](#) can be fine tuned with V_{BUS} OVP voltage selection thanks to R0 position change or via USB BC 1.2 check on source (short on D+/-) thanks to R8 and R9 zero Ohm resistor position change to R10 and R11 positions.
This configuration is relevant for a battery-powered device thanks to the low power mode (V_{cc} connected to GPIO). This results in zero power consumption for the [TCPP01-M12](#) when the Type-C cable is unplugged.

7 Jumper tables

Table 1. JP1 connector

Jumper	NUCLEO-G071RB selection	NUCLEO-G474RE selection
CC1_G0		
CC2_G0		
CC1_G4		
CC2_G4		

Table 2. JP2 connector - low power mode

Jumper	ST-LINK powered	USB-Type-C powered	USB-Type-C powered ST-LINK removed
LDO OUT-3.3 V			
3.3 V-NRST			
FLT-FLT_IN			
V _{CC} -3.3 V			
V _{CC} -V _{CC_OUT}			
DB-3.3 V			
DB-DB_OUT			

Table 3. JP2 connector - no low power mode

Jumper	ST-LINK powered	USB-Type-C powered	USB-Type-C powered ST-LINK removed
LDO OUT-3.3 V			
3.3 V-NRST			
FLT-FLT_IN			
V _{CC} -3.3 V			
V _{CC} -V _{CC_OUT}			
DB-3.3 V			
DB-DB_OUT			

8 Schematic diagrams

Figure 3. X-NUCLEO-USBPDM1 circuit schematic (1 of 2)

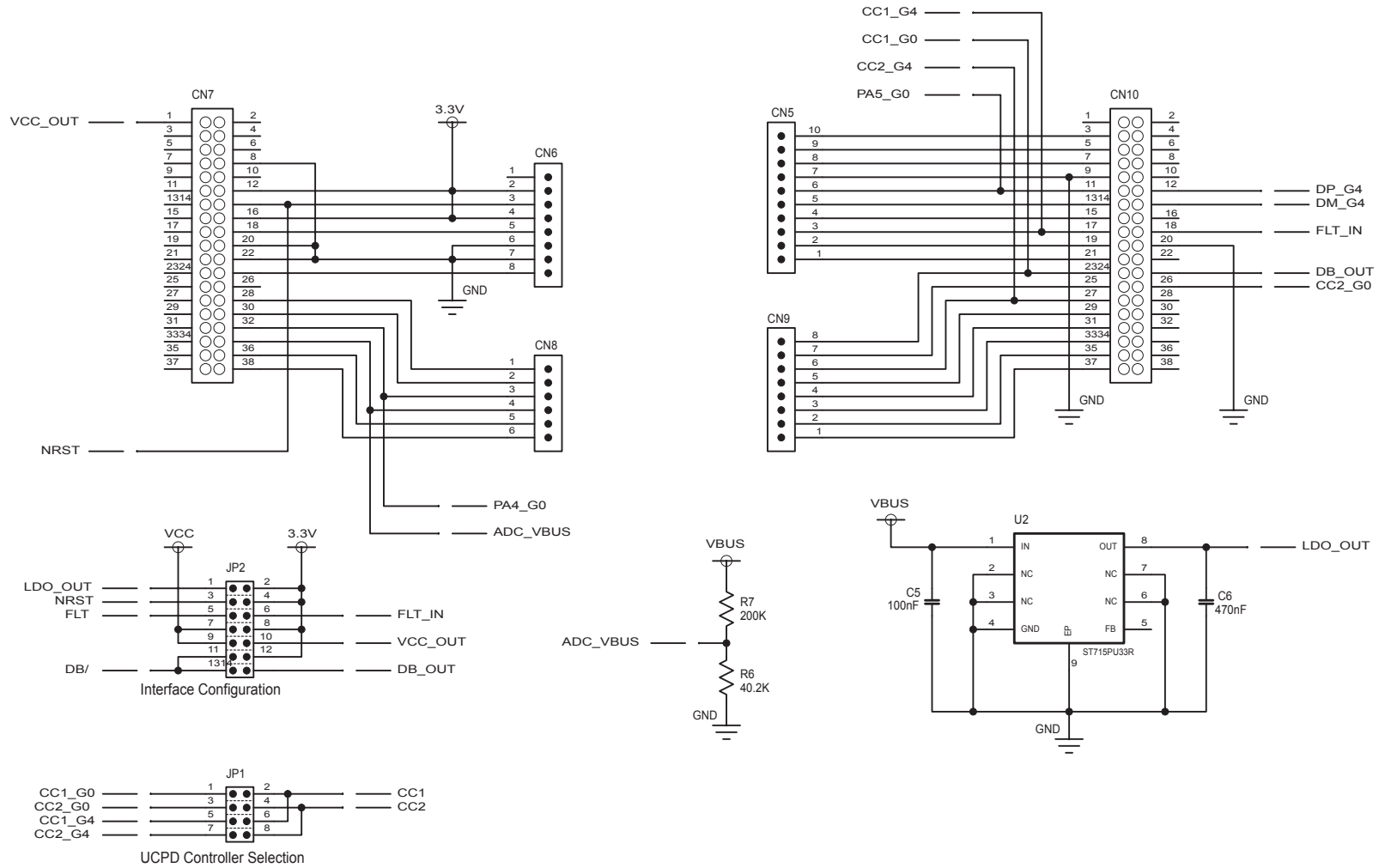

9 Bill of materials

Table 4. X-NUCLEO-USBPDM1 bill of materials

Item	Q.ty	Ref.	Part/Value	Description	Manufacturer	Order code
1	1	CN1	USB_TypeC_Rec eptacle	Type-C connector	Würth Electronics Inc.	632723300011
2	1	CN2	Through-hole, 2x1, 2.54 mm pitch	Screw connector	Würth Electronics Inc.	691210910002
3	2	CN7, CN10	Strip 19x2, 2.54 mm pitch	ST morpho connector	SAMTEC	ESQ-119-24-T-D
4	1	CN5	10 pins, 2.54 mm pitch	Arduino UNO R3 connector	Würth Electronics Inc.	61301011821
5	2	CN6, CN9	11 pins, 2.54 mm pitch	Arduino UNO R3 connector	Würth Electronics Inc.	61300811821
6	1	CN8	12 pins, 2.54 mm pitch	Arduino UNO R3 connector	Würth Electronics Inc.	61300611821
7	2	C1, C2	330 pF, SMD 0402, X7R, 50 Vdc	Multilayer ceramic capacitors	Würth Electronics Inc.	885012205058
8	2	C3, C5	100 nF, SMD 0402, X7R, 50 Vdc	Multilayer ceramic capacitors	Any	Any
9	1	C6	470 nF, SMD 0402, X5C, 6 Vdc	Multilayer ceramic capacitors	Any	Any
10	5	R0, R8, R9	SMD 0, 0402	Resistors	Any	Any
11	1	R1_6V	2.7 k, SMD, 0402, 1/4 W, ±1%	Resistor	Any	Any
12	1	R1_10V	1.5 K, SMD, 0402 ±1%	Resistor	Any	Any
13	1	R1_13V	1.1 k, SMD, 0402 ±1%	Resistor	Any	Any
14	1	R1_17V	820, SMD, 0402 , 1/4 W ±1%	Resistor	Any	Any
15	1	R1_22V	620 SSMD 620, 1, 0402 Resistor 620 1% 0402	Resistor	Any	Any
16	2	R2, R3	10 k, SMD 10k, 1, 0402 K 1% 0402	Resistor	Any	Any
17	1	R4	4 k, SMD 4k, 1, 0402 K 1% 0402	Resistor	Any	Any
18	1	R5	1 k, SMD 1k, 1, 0402 K 1% 0402	Resistor	Any	Any
19	1	R6	40 k, SMD 40, 2k, 1, 0402 K 1% 0402	Resistor	Any	Any
20	1	R7	200 k, SMD 200k, 1, 0402 K 1% 0402	Resistor	Any	Any

Item	Q.ty	Ref.	Part/Value	Description	Manufacturer	Order code
21	1	LD1	SMD 0603	Red LED	Würth Electronics Inc.	150060RS75000
22	1	LD2	SMD 0603	Green LED	Würth Electronics Inc.	150060GS75000
23	1	Q1	30 V, 11 A, PowerFLAT 3.3 x 3.3	N-channel 30 V, 6 mOhm typ., 11 A STripFET H6 Power MOSFET	ST	STL11N3LLH6
24	1	D1	25 V, 35 A	High-power transient voltage suppressor (TVS)	ST	ESDA25P35-1U1M
25	1	D2	300 mA, 40 V, SOD523	General purpose signal Schottky diode	ST	BAT54KFILM
26	1	U1	μQFN	USB Type-C port protection	ST	TCPP01-M12
27	1	U2	24 V, 4 V, 85 mA, DFN8	High input voltage LDO linear regulator	ST	ST715PU33R
28	1	U3	QFN-6L	Common-mode filter and ESD protection for USB 2.0 and MIPI/MDDI interfaces	ST	ECMF02-2AMX6
29	1	JP1	2.54 mm 2x4	Jumper	Würth Electronics Inc.	61300821121
30	1	JP2	2.54 mm 2x7	Jumper	Würth Electronics Inc.	61301421121
31	7		2.54 mm	Header	Würth Electronics Inc.	61300711121

Revision history

Table 5. Document revision history

Date	Version	Changes
17-Dec-2019	1	Initial release.
14-May-2020	2	Updated Introduction and Section 1.1 Overview.

Contents

1	Getting started	2
1.1	Overview	2
1.2	Hardware requirements	2
1.3	Software requirements	3
2	Board component description and configuration	4
2.1	Connectors	4
2.2	Jumpers	4
2.3	LEDs	4
2.4	V _{BUS} overvoltage protection setup	4
2.5	USB Type-C D+/D- connections	5
3	Programming and debugging	6
4	USB Type-C powered mode	7
5	NUCLEO-G474RE Type-C powered mode Sink contract negotiation	8
6	NUCLEO-G071RB Type-C powered mode Sink contract negotiation	9
7	Jumper tables	10
8	Schematic diagrams	11
9	Bill of materials	13
	Revision history	15

List of tables

Table 1.	JP1 connector	10
Table 2.	JP2 connector - low power mode	10
Table 3.	JP2 connector - no low power mode	10
Table 4.	X-NUCLEO-USBPDM1 bill of materials	13
Table 5.	Document revision history	15

List of figures

Figure 1.	X-NUCLEO-USBPDM1 expansion board	1
Figure 2.	X-NUCLEO-USBPDM1 plugged on an STM32 Nucleo board	2
Figure 3.	X-NUCLEO-USBPDM1 circuit schematic (1 of 2)	11
Figure 4.	X-NUCLEO-USBPDM1 circuit schematic (2 of 2)	12

IMPORTANT NOTICE – PLEASE READ CAREFULLY

STMicroelectronics NV and its subsidiaries (“ST”) reserve the right to make changes, corrections, enhancements, modifications, and improvements to ST products and/or to this document at any time without notice. Purchasers should obtain the latest relevant information on ST products before placing orders. ST products are sold pursuant to ST’s terms and conditions of sale in place at the time of order acknowledgement.

Purchasers are solely responsible for the choice, selection, and use of ST products and ST assumes no liability for application assistance or the design of Purchasers’ products.

No license, express or implied, to any intellectual property right is granted by ST herein.

Resale of ST products with provisions different from the information set forth herein shall void any warranty granted by ST for such product.

ST and the ST logo are trademarks of ST. For additional information about ST trademarks, please refer to www.st.com/trademarks. All other product or service names are the property of their respective owners.

Information in this document supersedes and replaces information previously supplied in any prior versions of this document.

© 2020 STMicroelectronics – All rights reserved