

NB6L239MNEVB

NB6L239MNEVB Evaluation Board User's Manual



ON Semiconductor®

<http://onsemi.com>

EVAL BOARD USER'S MANUAL

Description

The NB6L239 Evaluation Board was designed to provide a flexible and convenient platform to quickly evaluate, characterize and verify the performance and operation of the NB6L239. This user's manual provides detailed information on board contents, layout and its use. It should be used in conjunction with the NB6L239 data sheet: (www.onsemi.com).

The NB6L239 is a differential Receiver to differential LVPECL Clock Divider. The board features Output Enable control of the Outputs.

Board Features

- Accommodates the electrical characterization of the NB6L239
- Selectable Jumper for the VT pin, minimizing cabling
- CLK/ $\overline{\text{CLK}}$ input and QA/ $\overline{\text{QA}}$ and QB/ $\overline{\text{QB}}$ output pins are accessed via SMA connectors
- $\overline{\text{MR}}$, $\overline{\text{EN}}$ and Clock Divide Select pins are accessed via SMA Connectors or by the Logic Switches
- Convenient and compact board layout
- 2.5 V, 3.3 V Power Supply Operating Range

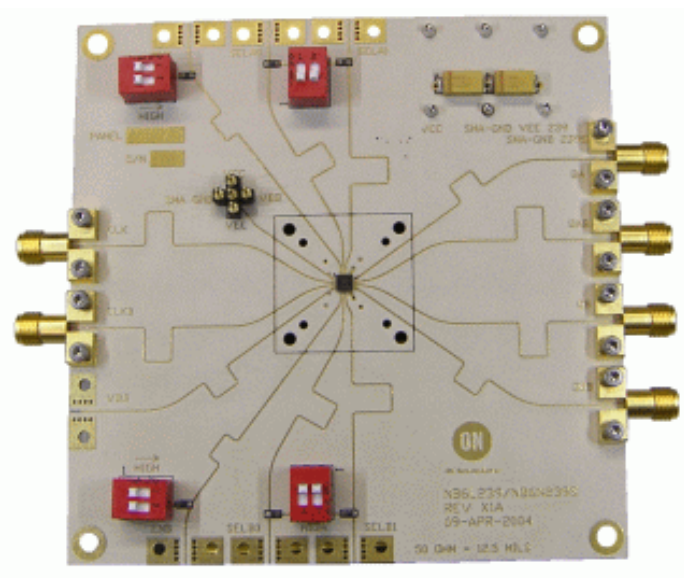
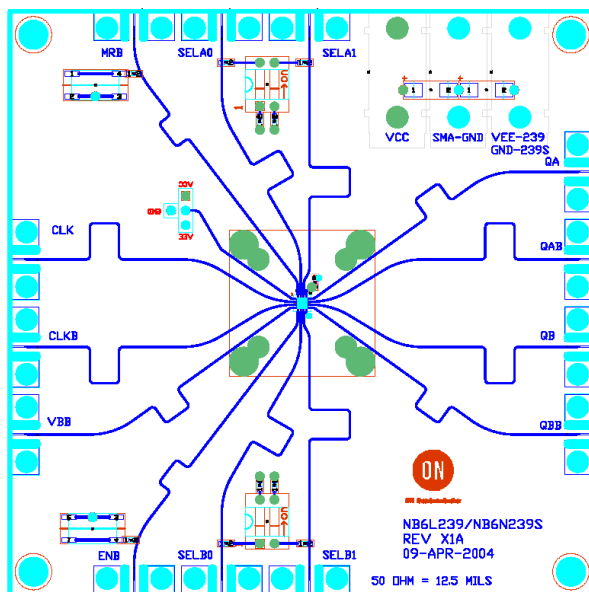

Figure 1. Evaluation Board

NB6L239MNEVB

PROCEDURE

Lab Setup and Measurement Procedure

Equipment Used

- Agilent Signal Generator #8133A
- Tektronix TDS8000 Oscilloscope
- Agilent #6624A DC Power Supply
- Digital Voltmeter
- Matched High-Speed Cables with SMA Connectors

Power Supply Connections

The NB6L239 has a positive supply pin, V_{CC} , and a negative supply pin, V_{EE} . $SMAGND = V_{TT} = V_{CC} - 2.0\text{ V}$ is the termination supply for the LVPECL outputs, only.

Power supply terminals V_{CC} , V_{EE} and $SMAGND$ are provided. The $SMAGND$ terminal is for the isolated SMA connector GROUND plane, and is not to be confused with a device V_{EE} pin. Since $SMAGND = V_{TT} = V_{CC} - 2.0\text{ V}$, is the termination supply for the LVPECL outputs, by offsetting V_{CC} by $+2.0\text{ V}$ yields $V_{TT} = 0\text{ V}$ or Ground. A “split” or dual power supply technique can be used to take advantage of terminating the PECL outputs into $50\ \Omega$ to Ground of an oscilloscope or a frequency counter. (see AND8020/D for more information on terminating ECL).

Table 1. POWER SUPPLY CONFIGURATIONS

Device Pin	Power Supply Connector Color	“Split” Power Supply
V_{CC}	RED	$V_{CC} = +2.0\text{ V}$
-	BLACK - SMAGND	$V_{TT} = V_{CC} - 2\text{ V} = 0\text{ V}$
$V_{EE} - 239$	YELLOW	$V_{EE} = -1.3\text{ V}$ (or -0.5 V)

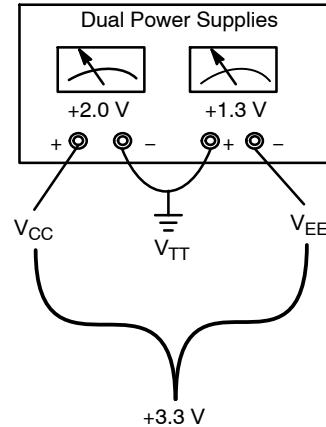

Figure 2. “Split” or Dual Power Supply Connections

NB6L239

To monitor the QA/\overline{QA} and QB/\overline{QB} outputs on an oscilloscope, the power supply needs to be DC offset:

1. Connect a “split” power supply to the evaluation board. (Figure 1)
 - Connect V_{CC} to $+2.0\text{ V}$
 - Connect $SMAGND$ to 0 V
 - Connect V_{EE} to -1.3 V for 3.3 V operation; or -0.5 V for 2.5 V operation
2. Ensure the oscilloscope is triggered properly and has $50\ \Omega$ termination to ground. The board does not provide $50\ \Omega$ source termination resistors. Trigger the oscilloscope from trigger output of signal generator.
3. Connect the LVPECL QA/\overline{QA} and QB/\overline{QB} outputs to the oscilloscope with matched cables. The outputs are terminated with $50\ \Omega$ to V_{TT} ($V_{CC} - 2.0\text{ V}$) = 0 V = Ground internal to the oscilloscope.

NB6L239MNEVB

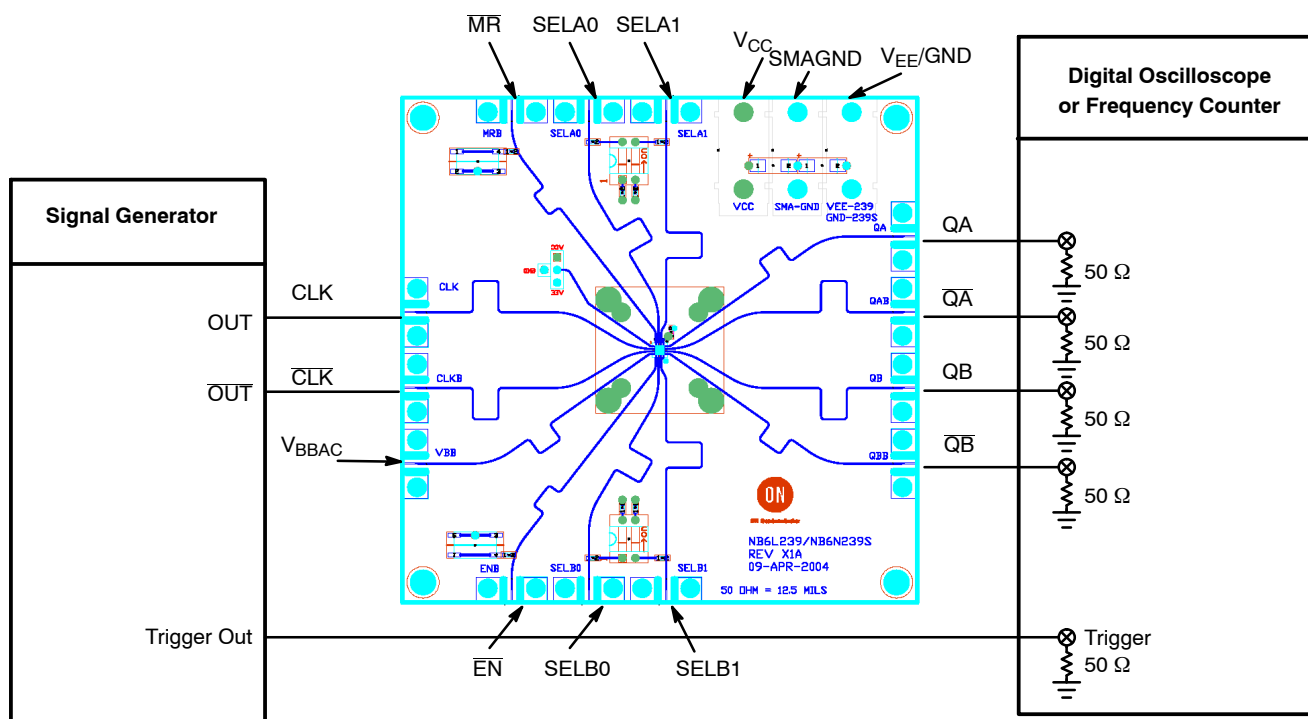

Figure 3. Evaluation Board

Board Layout

The evaluation board is constructed with Rogers material with 50 Ω trace impedances designed to minimize noise, achieve high bandwidth and minimize crosstalk.

Layer Stack

- L1 Signal (top) (Rogers)
- L2 SMA Ground
- L3 V_{CC} and V_{EE} (positive and negative power supply)
- L4 Signal (bottom)

Control and Select Pins

The Control / Select pins, \overline{MR} , $SELX_n$ and \overline{EN} , can be accessed via the appropriate SMA connector. These pins can also be manually controlled by using the H/L switch. When using the switch, the SMA connector should be left open. When using the SMA connector, the switch must be in the “OPEN” position.

The $SELX_n$ and \overline{EN} device pins have internal pulldown resistors. The NB6L239 evaluation board was designed to take advantage of this attribute. When the $SELX_n$ and \overline{EN} switch is in the logic LOW position, the input pin “floats” to

a logic LOW owing to the pulldown resistor; a logic LOW voltage is not forced on the pin. In the HIGH position, the switch forces the $SELX_n$ and \overline{EN} pin to the positive power supply rail, a logic HIGH.

The \overline{MR} device pin has an internal pullup resistor. When the \overline{MR} switch is in the logic HIGH position, the input pin “floats” to a logic HIGH owing to the pullup resistor; a logic HIGH voltage is not forced on the pin. In the LOW position, the switch forces the \overline{MR} pin to the negative power supply rail, a logic LOW.

$V_{BB} = V_{BBAC}$

V_{BB} labeled on the board is actually V_{BBAC} per the data sheet.

V_T

The V_T pin can be set to V_{CC} , V_{EE} (239) GND (239S), V_{BB} or SMAGND by using a jumper.

V_{EE} / GND

V_{EE} is the negative supply for the NB6L239. GND is the negative supply for NB6N239S.

NB6L239MNEVB

Table 2. PIN DESCRIPTION (refer to data sheet, NB6L239/D)

Pin # 16-QFN	Pin Name	I/O	Open Pin Default	Type	Function
1	VT				Internal 100 Ω Center
2	CLK	Input		LVPECL, CML, LVDS, HSTL	Noninverted Differential CLOCK Input.
3	$\overline{\text{CLK}}$	Input		LVPECL, CML, LVDS, HSTL	Inverted Differential CLOCK Input.
4	V _{BBAC}	Output		Reference Voltage	Output Voltage Reference for Capacitor Coupled Inputs, Only.
5	EN	Input	L	LVC MOS/LVTTL Input	Synchronous Output Enable
6	SELB0	Input	L	LVC MOS/LVTTL Input	Clock Divide Select Pin
7	SELB1	Input	L	LVC MOS/LVTTL Input	Clock Divide Select Pin
8	V _{EE}	Negative Power Supply			Negative Supply Voltage
9	$\overline{\text{QB}}$	Output		LVPECL	Inverted Differential Output. Typically terminated with 50 Ω resistor to V _{TT} .
10	QB	Output		LVPECL	Noninverted Differential Output. Typically terminated with 50 Ω resistor to V _{TT} .
11	$\overline{\text{QA}}$	Output		LVPECL	Inverted Differential Output. Typically terminated with 50 Ω resistor to V _{TT} .
12	QA	Output		LVPECL	Noninverted Differential Output. Typically terminated with 50 Ω resistor to V _{TT} .
13	V _{CC}	Positive Power Supply			Positive Power Supply
14	SELA1	Input	L	LVC MOS/LVTTL	Clock Divide Select Pin
15	SELA0	Input	L	LVC MOS/LVTTL Input	Clock Divide Select Pin
16	$\overline{\text{MR}}$	Input	H	LVC MOS/LVTTL Input	Master Reset Asynchronous, Default Open High, Asserted LOW
	EP	Negative Power Supply (opt)			The Exposed Pad on the QFN-16 package bottom is thermally connected to the die for improved heat transfer out of package. The pad is not electrically connected to the die, but is recommended to be electrically and thermally connected to V _{EE} on the PC board.

NB6L239MNEVB

EVALUATION BOARD APPLICATION INFORMATION

Table 3. EVALUATION BOARD BILL OF MATERIALS

Component	Description	Qty
Connector	Rosenberger SMA #32K243-40ME3	6
Capacitor	22 μ F, 10%, KEMET T491D226K016AS, Case C or D	2
Capacitor	0.1 μ F, 10%, KEMET C060C104K5RAC	4
Switch	Grayhill #78B02	4
Jumper Header	100 mil, Berg	5
Jumper/Shunt		1
Resistor	1 k Ω , 0603	6
Banana Jack	Deltron #EF681 150-039 Red	1
Banana Jack	Deltron #EF681 150-040 Black	1
Banana Jack	Deltron #EF681 150-043 Yellow	1
Stand-offs with Screws	Optional	4
NB6L239 or NB6N239S	QFN-16 Part Mounted on Board	1
QFN-16 Socket	Optional, M&M #50-000-00350	1

NB6L239MNEVB

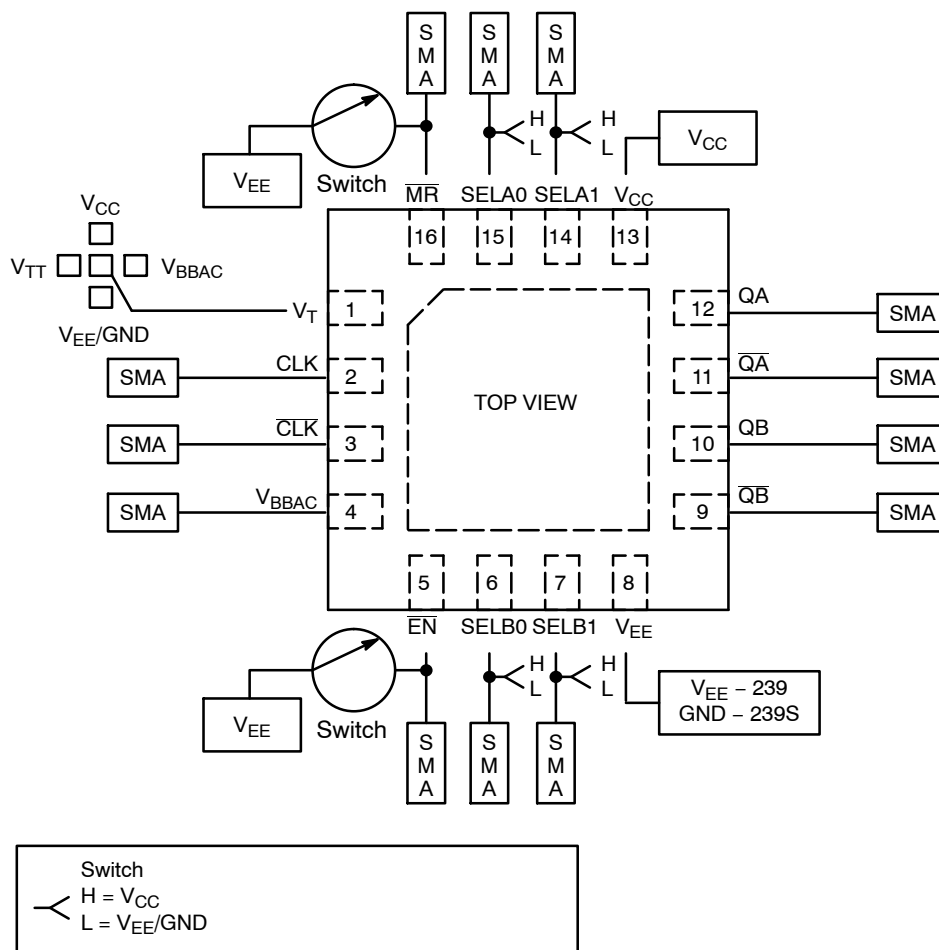

Rosenberger connectors with matched trace launches
 Switch for $\overline{M_R}$
 Normally open switch for $\overline{E_N}$
 CLK & \overline{CLK} traces – equal length
 All Q Output traces – equal length
 “Side-mount” banana jacks for power supplies (can be located on backside of board)
 V_T pin has a “jumper capability to V_{CC} , V_{EE} / GND , V_{TT} (SMAGND), or V_{BBAC} ”

Figure 4. Evaluation Demo Board

ON Semiconductor and the ON Semiconductor logo are trademarks of Semiconductor Components Industries, LLC dba ON Semiconductor or its subsidiaries in the United States and/or other countries. ON Semiconductor owns the rights to a number of patents, trademarks, copyrights, trade secrets, and other intellectual property. A listing of ON Semiconductor's product/patent coverage may be accessed at www.onsemi.com/site/pdf/Patent-Marking.pdf. ON Semiconductor is an Equal Opportunity/Affirmative Action Employer. This literature is subject to all applicable copyright laws and is not for resale in any manner.

The evaluation board/kit (research and development board/kit) (hereinafter the "board") is not a finished product and is as such not available for sale to consumers. The board is only intended for research, development, demonstration and evaluation purposes and should as such only be used in laboratory/development areas by persons with an engineering/technical training and familiar with the risks associated with handling electrical/mechanical components, systems and subsystems. This person assumes full responsibility/liability for proper and safe handling. Any other use, resale or redistribution for any other purpose is strictly prohibited.

The board is delivered "AS IS" and without warranty of any kind including, but not limited to, that the board is production-worthy, that the functions contained in the board will meet your requirements, or that the operation of the board will be uninterrupted or error free. ON Semiconductor expressly disclaims all warranties, express, implied or otherwise, including without limitation, warranties of fitness for a particular purpose and non-infringement of intellectual property rights.

ON Semiconductor reserves the right to make changes without further notice to any board.

You are responsible for determining whether the board will be suitable for your intended use or application or will achieve your intended results. Prior to using or distributing any systems that have been evaluated, designed or tested using the board, you agree to test and validate your design to confirm the functionality for your application. Any technical, applications or design information or advice, quality characterization, reliability data or other services provided by ON Semiconductor shall not constitute any representation or warranty by ON Semiconductor, and no additional obligations or liabilities shall arise from ON Semiconductor having provided such information or services.

The boards are not designed, intended, or authorized for use in life support systems, or any FDA Class 3 medical devices or medical devices with a similar or equivalent classification in a foreign jurisdiction, or any devices intended for implantation in the human body. Should you purchase or use the board for any such unintended or unauthorized application, you shall indemnify and hold ON Semiconductor and its officers, employees, subsidiaries, affiliates, and distributors harmless against all claims, costs, damages, and expenses, and reasonable attorney fees arising out of, directly or indirectly, any claim of personal injury or death associated with such unintended or unauthorized use, even if such claim alleges that ON Semiconductor was negligent regarding the design or manufacture of the board.

This evaluation board/kit does not fall within the scope of the European Union directives regarding electromagnetic compatibility, restricted substances (RoHS), recycling (WEEE), FCC, CE or UL, and may not meet the technical requirements of these or other related directives.

FCC WARNING – This evaluation board/kit is intended for use for engineering development, demonstration, or evaluation purposes only and is not considered by ON Semiconductor to be a finished end product fit for general consumer use. It may generate, use, or radiate radio frequency energy and has not been tested for compliance with the limits of computing devices pursuant to part 15 of FCC rules, which are designed to provide reasonable protection against radio frequency interference. Operation of this equipment may cause interference with radio communications, in which case the user shall be responsible, at its expense, to take whatever measures may be required to correct this interference.

ON Semiconductor does not convey any license under its patent rights nor the rights of others.

LIMITATIONS OF LIABILITY: ON Semiconductor shall not be liable for any special, consequential, incidental, indirect or punitive damages, including, but not limited to the costs of requalification, delay, loss of profits or goodwill, arising out of or in connection with the board, even if ON Semiconductor is advised of the possibility of such damages. In no event shall ON Semiconductor's aggregate liability from any obligation arising out of or in connection with the board, under any theory of liability, exceed the purchase price paid for the board, if any.

For more information and documentation, please visit www.onsemi.com.

PUBLICATION ORDERING INFORMATION

LITERATURE FULFILLMENT:

Email Requests to: orderlit@onsemi.com

ON Semiconductor Website: www.onsemi.com

TECHNICAL SUPPORT

North American Technical Support:

Voice Mail: 1 800-282-9855 Toll Free USA/Canada

Phone: 011 421 33 790 2910

Europe, Middle East and Africa Technical Support:

Phone: 00421 33 790 2910

For additional information, please contact your local Sales Representative