

# TPS61193 High-Performance Three-Channel LED Driver

## 1 Features

- Input Voltage Operating Range 4.5 V to 40 V
- Three High-Precision Current Sinks
  - Current Matching 1% (Typical)
  - LED String Current up to 100 mA per Channel
  - Outputs can be Combined Externally for Higher Current Capability
- High Dimming Ratio of 10 000:1 at 100 Hz
- Integrated Boost/SEPIC for LED String Power
  - Output Voltage up to 45 V
  - Switching Frequency 300 kHz to 2.2 MHz
  - Switching Synchronization Input
  - Spread Spectrum for Lower EMI
- Extensive Fault Detection Features
  - Fault Output
  - Input Voltage OVP, UVLO, and OCP
  - Open and Shorted LED Fault Detection
  - Thermal Shutdown
- Minimum Number of External Components

## 2 Applications

- Industrial Backlighting Systems in Control Panels
- Industrial PC
- Test and Measurement Equipment

## 3 Description

The TPS61193 is a high-efficiency, low-EMI, easy-to-use LED driver with flexibility to support a wide range of applications. It has three high-precision current sinks that can be combined for higher current capability.

The TPS61193 has an integrated DC-DC supporting both boost and SEPIC mode operation. The converter has adaptive output voltage control based on the LED current sink headroom voltages. This feature minimizes the power consumption by adjusting the voltage to lowest sufficient level in all conditions. For EMI control the DC-DC converter supports spread spectrum for switching frequency and an external synchronization with dedicated pin.

The TPS61193 has wide input voltage range from 4.5 V to 40 V for robust support of different types of applications. The TPS61193 integrates extensive fault detection features. The device supports PWM brightness dimming ratio of 10 000:1 for 100-Hz input PWM frequency.

### Simplified Schematic

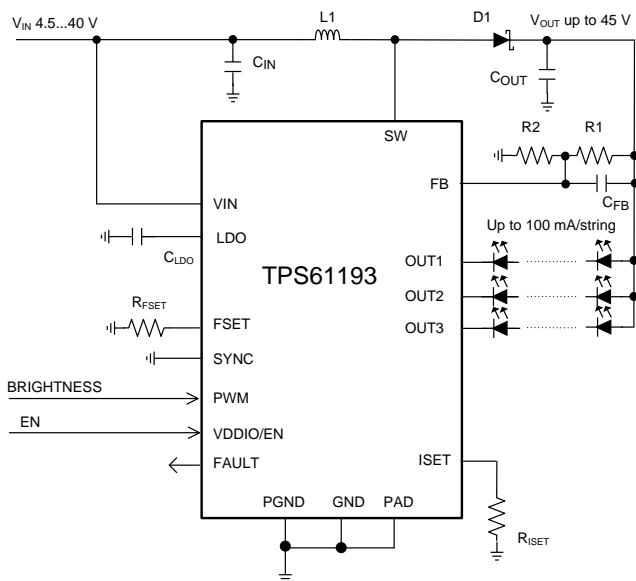

Copyright © 2016, Texas Instruments Incorporated

### Device Information<sup>(1)</sup>

PART NUMBER	PACKAGE	BODY SIZE (NOM)
TPS61193	HTSSOP (20)	6.50 mm × 4.40 mm

(1) For all available packages, see the orderable addendum at the end of the data sheet.

### System Efficiency

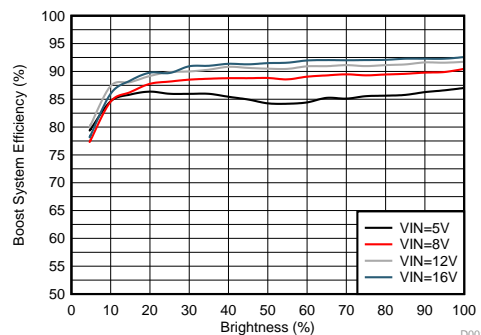

D001



## Table of Contents

<b>1</b>	<b>Features</b> .....	<b>1</b>	7.2	Functional Block Diagram .....	<b>11</b>
<b>2</b>	<b>Applications</b> .....	<b>1</b>	7.3	Feature Description .....	<b>12</b>
<b>3</b>	<b>Description</b> .....	<b>1</b>	7.4	Device Functional Modes .....	<b>18</b>
<b>4</b>	<b>Revision History</b> .....	<b>2</b>	<b>8</b>	<b>Application and Implementation</b> .....	<b>20</b>
<b>5</b>	<b>Pin Configuration and Functions</b> .....	<b>3</b>	8.1	Application Information .....	<b>20</b>
<b>6</b>	<b>Specifications</b> .....	<b>4</b>	8.2	Typical Applications .....	<b>20</b>
6.1	Absolute Maximum Ratings .....	<b>4</b>	<b>9</b>	<b>Power Supply Recommendations</b> .....	<b>25</b>
6.2	ESD Ratings .....	<b>4</b>	<b>10</b>	<b>Layout</b> .....	<b>26</b>
6.3	Recommended Operating Conditions .....	<b>4</b>	10.1	Layout Guidelines .....	<b>26</b>
6.4	Thermal Information .....	<b>5</b>	10.2	Layout Example .....	<b>27</b>
6.5	Electrical Characteristics .....	<b>5</b>	<b>11</b>	<b>Device and Documentation Support</b> .....	<b>28</b>
6.6	Internal LDO Electrical Characteristics .....	<b>5</b>	11.1	Device Support .....	<b>28</b>
6.7	Protection Electrical Characteristics .....	<b>6</b>	11.2	Documentation Support .....	<b>28</b>
6.8	Current Sinks Electrical Characteristics .....	<b>6</b>	11.3	Receiving Notification of Documentation Updates .....	<b>28</b>
6.9	PWM Brightness Control Electrical Characteristics .....	<b>6</b>	11.4	Community Resources .....	<b>28</b>
6.10	Boost and SEPIC Converter Characteristics .....	<b>7</b>	11.5	Trademarks .....	<b>28</b>
6.11	Logic Interface Characteristics .....	<b>7</b>	11.6	Electrostatic Discharge Caution .....	<b>28</b>
6.12	Typical Characteristics .....	<b>8</b>	11.7	Glossary .....	<b>28</b>
<b>7</b>	<b>Detailed Description</b> .....	<b>10</b>	<b>12</b>	<b>Mechanical, Packaging, and Orderable Information</b> .....	<b>28</b>
7.1	Overview .....	<b>10</b>			

## 4 Revision History

Changes from Revision A (September 2016) to Revision B	Page
• Enhanced pin descriptions for pins 3, 10, and 16 in <i>Pin Functions</i> table .....	<b>3</b>
• Deleted "I <sub>OUT</sub> = 100 mA" from t <sub>ON/OFF</sub> row of <i>PWM Brightness Control Electrical Characteristics</i> .....	<b>6</b>
• Changed "0.5" from MAX to TYP column in t <sub>ON/OFF</sub> row of <i>PWM Brightness Control Electrical Characteristics</i> ; add note 1 to <i>PWM Brightness Control Electrical Characteristics</i> .....	<b>6</b>
• Added table note 1 for <i>Boost and SEPIC Converter Characteristics</i> .....	<b>7</b>
• Deleted "Initial DC-DC voltage is about 88% of V <sub>MAX BOOST</sub> ." from <i>Integrated DC-DC Converter</i> ; change wording in last sentence before <i>Equation 1</i> .....	<b>12</b>
• Changed <i>Equation 1</i> and added "K" eq definitions; added new paragraph after <i>Figure 9</i> .....	<b>12</b>
• Added new paragraph before <i>Internal LDO</i> .....	<b>14</b>
• Deleted "Dimming ratio is calculated as ratio between the input PWM period and minimum on/off time (0.5 μs). " from <i>Brightness Control</i> .....	<b>14</b>

Changes from Original (October 2015) to Revision A	Page
• Changed several wording of several items in <i>Features</i> .....	<b>1</b>
• Changed "High Dimming Ratio of 10 000:1 at 200 Hz" to "High Dimming Ratio of 10 000:1 at 100 Hz" .....	<b>1</b>
• Added last sentence of first paragraph in <i>Description</i> section .....	<b>1</b>
• Changed "dimming ratio of 10 000:1 for 200-Hz" to "dimming ratio of 10 000:1 for 100-Hz" .....	<b>1</b>
• Added last sentence of <i>Description</i> section .....	<b>1</b>
• Added standard footnotes for the <i>ESD Ratings</i> table .....	<b>4</b>
• Added Figures 7 and 8 - new graphs .....	<b>9</b>

## 5 Pin Configuration and Functions

**PWP Package**  
**20-Pin TSSOP With Exposed Thermal Pad**  
**Top View**

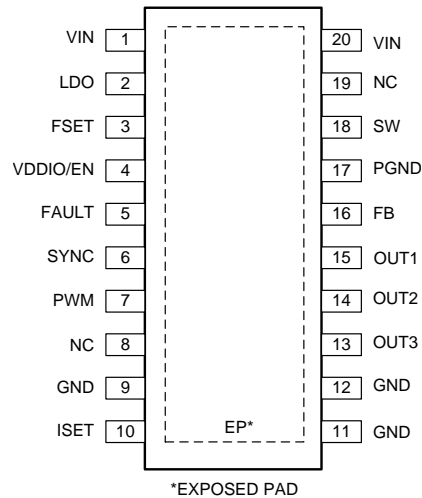

### Pin Functions

PIN		TYPE <sup>(1)</sup>	DESCRIPTION
NO.	NAME		
1	VIN	A	Input power pin
2	LDO	A	Output of internal LDO; connect a 1- $\mu$ F decoupling capacitor between this pin and noise-free GND.
3	FSET	A	DC-DC (boost or SEPIC) switching frequency setting resistor; for normal operation, resistor value from 24 k $\Omega$ to 219 k $\Omega$ must be connected between this pin and ground.
4	VDDIO/EN	I	Enable input for the device as well as supply input (VDDIO) for digital pins
5	FAULT	OD	Fault signal output. If unused, the pin may be left floating.
6	SYNC	I	Input for synchronizing boost. If synchronization is not used, connect this pin to GND to disable spread spectrum or to VDDIO/EN to enable spread spectrum.
7	PWM	I	PWM dimming input.
8	NC	—	No connect
9	GND	G	Ground.
10	ISET	A	LED current setting resistor; for normal operation, resistor value from 24 k $\Omega$ to 129 k $\Omega$ must be connected between this pin and ground.
11	GND	G	Ground
12	GND	G	Ground
13	OUT3	A	Current sink output; this pin must be connected to GND if not used.
14	OUT2	A	Current sink output This pin must be connected to GND if not used.
15	OUT1	A	Current sink output This pin must be connected to GND if not used.
16	FB	A	Boost/SEPIC feedback input; for normal operation this pin must be connected to the middle of a resistor divider between VOUT and ground using feedback resistor values between 5 k $\Omega$ and 150 k $\Omega$ .
17	PGND	G	DC-DC (boost or SEPIC) power ground
18	SW	A	DC-DC (boost or SEPIC) switch pin
19	NC	A	No connect
20	VIN	A	Input power pin

(1) A: Analog pin, G: Ground pin, P: Power pin, I: Input pin, I/O: Input/Output pin, O: Output pin, OD: Open Drain pin

## 6 Specifications

### 6.1 Absolute Maximum Ratings

Over operating free-air temperature range (unless otherwise noted)<sup>(1)(2)</sup>

		MIN	MAX	UNIT
Voltage on pins	VIN, SW, FB	-0.3	50	V
	OUT1, OUT2, OUT3	-0.3	45	
	LDO, SYNC, FSET, ISET, PWM, VDDIO/EN, FAULT	-0.3	5.5	
Continuous power dissipation <sup>(3)</sup>		Internally Limited		
Ambient temperature range $T_A$ <sup>(4)</sup>		-40	125	°C
Junction temperature range $T_J$ <sup>(4)</sup>		-40	150	°C
Maximum lead temperature (soldering)			See <sup>(5)</sup>	
Storage temperature, $T_{stg}$		-65	150	°C

- (1) Stresses beyond those listed under absolute maximum ratings may cause permanent damage to the device. These are stress ratings only, and functional operation of the device at these or any other conditions beyond those indicated under recommended operating conditions is not implied. Exposure to absolute-maximum-rated conditions for extended periods may affect device reliability.
- (2) All voltages are with respect to the potential at the GND pins.
- (3) Internal thermal shutdown circuitry protects the device from permanent damage. Thermal shutdown engages at  $T_J = 165^\circ\text{C}$  (typical) and disengages at  $T_J = 145^\circ\text{C}$  (typical).
- (4) In applications where high power dissipation and/or poor package thermal resistance is present, the maximum ambient temperature may have to be derated. Maximum ambient temperature ( $T_{A-MAX}$ ) is dependent on the maximum operating junction temperature ( $T_{J-MAX-OP} = 150^\circ\text{C}$ ), the maximum power dissipation of the device in the application ( $P_{D-MAX}$ ), and the junction-to ambient thermal resistance of the part/package in the application ( $R_{\theta JA}$ ), as given by the following equation:  $T_{A-MAX} = T_{J-MAX-OP} - (R_{\theta JA} \times P_{D-MAX})$ .
- (5) For detailed soldering specifications and information, refer to [PowerPAD™ Thermally Enhanced Package](#).

### 6.2 ESD Ratings

			VALUE	UNIT	
$V_{(ESD)}$	Electrostatic discharge	Human-body model (HBM), per JESD22-A114, JS-001 <sup>(1)</sup>	±2000	V	
		Charged-device model (CDM), per JESD22-C101	All other pins		±500
			Corner pins (1,10,11,20)		±750

- (1) JEDEC document JEP155 states that 500-V HBM allows safe manufacturing with a standard ESD control process.

### 6.3 Recommended Operating Conditions

Over operating free-air temperature range (unless otherwise noted)<sup>(1)</sup>

		MIN	MAX	UNIT
Voltage on pins	VIN	4.5	45	V
	SW	0	45	
	OUT1, OUT2, OUT3	0	40	
	FB, FSET, LDO, ISET, VDDIO/EN, FAULT	0	5.25	
	SYNC, PWM	0	VDDIO/EN	

- (1) All voltages are with respect to the potential at the GND pins.

## 6.4 Thermal Information

THERMAL METRIC <sup>(1)</sup>		TPS61193	
		PWP (TSSOP)	UNIT
		20 PINS	
$R_{\theta JA}$	Junction-to-ambient thermal resistance <sup>(2)</sup>	44.2	°C/W
$R_{\theta JCTop}$	Junction-to-case (top) thermal resistance	26.5	°C/W
$R_{\theta JB}$	Junction-to-board thermal resistance	22.4	°C/W
$\psi_{JT}$	Junction-to-top characterization parameter	0.9	°C/W
$\psi_{JB}$	Junction-to-board characterization parameter	22.2	°C/W
$R_{\theta JCbott}$	Junction-to-case (bottom) thermal resistance	2.5	°C/W

(1) For more information about traditional and new thermal metrics, see [Semiconductor and IC Package Thermal Metrics](#).

(2) Junction-to-ambient thermal resistance is highly application and board-layout dependent. In applications where high maximum power dissipation exists, special care must be paid to thermal dissipation issues in board design.

## 6.5 Electrical Characteristics<sup>(1)(2)</sup>

$T_J = -40^{\circ}\text{C}$  to  $+125^{\circ}\text{C}$  (unless otherwise noted).

PARAMETER		TEST CONDITIONS	MIN	TYP	MAX	UNIT
$I_Q$	Standby supply current	Device disabled, $V_{VDDIO/EN} = 0\text{ V}$ , $V_{IN} = 12\text{ V}$		4.5	20	$\mu\text{A}$
	Active supply current	$V_{IN} = 12\text{ V}$ , $V_{OUT} = 26\text{ V}$ , output current 80 mA/channel, converter $f_{SW} = 300\text{ kHz}$		5	12	mA
$V_{POR\_R}$	Power-on reset rising threshold	LDO pin voltage			2.7	V
$V_{POR\_F}$	Power-on reset falling threshold	LDO pin voltage	1.5			V
$T_{TSD}$	Thermal shutdown threshold		150	165	175	°C
$T_{TSD\_HYST}$	Thermal shutdown hysteresis			20		°C

(1) All voltages are with respect to the potential at the GND pins.

(2) Minimum and maximum limits are specified by design, test, or statistical analysis.

## 6.6 Internal LDO Electrical Characteristics

$T_J = -40^{\circ}\text{C}$  to  $+125^{\circ}\text{C}$  (unless otherwise noted).

PARAMETER		TEST CONDITIONS	MIN	TYP	MAX	UNIT
$V_{LDO}$	Output voltage	$V_{IN} = 12\text{ V}$	4.15	4.3	4.55	V
$V_{DR}$	Dropout voltage		120	300	430	mV
$I_{SHORT}$	Short circuit current			50		mA

## 6.7 Protection Electrical Characteristics

 $T_J = -40^{\circ}\text{C}$  to  $+125^{\circ}\text{C}$  (unless otherwise noted).

PARAMETER		TEST CONDITIONS	MIN	TYP	MAX	UNIT
$V_{OVP}$	VIN OVP threshold voltage		41	42	44	V
$V_{UVLO}$	VIN UVLO			4		V
$V_{UVLO\_HYST}$	VIN UVLO hysteresis			100		mV
	LED short detection threshold		5.6	6	7	V

## 6.8 Current Sinks Electrical Characteristics

 $T_J = -40^{\circ}\text{C}$  to  $+125^{\circ}\text{C}$  (unless otherwise noted).

PARAMETER		TEST CONDITIONS	MIN	TYP	MAX	UNIT
$I_{LEAKAGE}$	Leakage current	Outputs OUT1 to OUT3, $V_{OUTx} = 45\text{ V}$		0.1	5	$\mu\text{A}$
$I_{MAX}$	Maximum current	OUT1, OUT2, OUT3		100		mA
$I_{OUT}$	Output current accuracy	$I_{OUT} = 100\text{ mA}$	-5%		5%	
$I_{MATCH}$	Output current matching <sup>(1)</sup>	$I_{OUT} = 100\text{ mA}$ , PWM duty = 100%		1%	5%	
$V_{SAT}$	Saturation voltage <sup>(2)</sup>	$I_{OUT} = 100\text{ mA}$		0.4	0.7	V

- (1) Output Current Accuracy is the difference between the actual value of the output current and programmed value of this current. Matching is the maximum difference from the average. For the constant current sinks on the part (OUTx), the following are determined: the maximum output current (MAX), the minimum output current (MIN), and the average output current of all outputs (AVG). Matching number is calculated:  $(MAX-MIN)/AVG$ . The typical specification provided is the most likely norm of the matching figure for all parts. LED current sinks were characterized with 1-V headroom voltage. Note that some manufacturers have different definitions in use.
- (2) Saturation voltage is defined as the voltage when the LED current has dropped 10% from the value measured at 1 V.

## 6.9 PWM Brightness Control Electrical Characteristics

 $T_J = -40^{\circ}\text{C}$  to  $+125^{\circ}\text{C}$  (unless otherwise noted).

PARAMETER		TEST CONDITIONS	MIN	TYP	MAX	UNIT
$f_{PWM}$	PWM input frequency		100		20 000	Hz
$t_{ON/OFF}$	Minimum on/off time <sup>(1)</sup>			0.5		$\mu\text{s}$

- (1) This specification is not ensured by ATE.

## 6.10 Boost and SEPIC Converter Characteristics

$T_J = -40^{\circ}\text{C}$  to  $+125^{\circ}\text{C}$  (unless otherwise noted).

Unless otherwise specified:  $V_{IN} = 12\text{ V}$ ,  $V_{EN/VDDIO} = 3.3\text{ V}$ ,  $L = 22\text{ }\mu\text{H}$ ,  $C_{IN} = 2 \times 10\text{-}\mu\text{F}$  ceramic and  $33\text{-}\mu\text{F}$  electrolytic,  $C_{OUT} = 2 \times 10\text{-}\mu\text{F}$  ceramic and  $33\text{-}\mu\text{F}$  electrolytic,  $D = \text{NRVB460MFS}$ ,  $f_{SW} = 300\text{ kHz}$ .

PARAMETER		TEST CONDITIONS	MIN	TYP	MAX	UNIT
$V_{IN}$	Input voltage		4.5		40	V
$V_{OUT}$	Output voltage		6		45	
$f_{SW\_MIN}$	Minimum switching frequency (central frequency if spread spectrum is enabled)	Defined by $R_{FSET}$ resistor		300		kHz
$f_{SW\_MAX}$	Maximum switching frequency (central frequency if spread spectrum is enabled)			2 200		kHz
$V_{OUT}/V_{IN}$	Conversion ratio				10	
$T_{OFF}$	Minimum switch OFF time <sup>(1)</sup>	$f_{SW} \geq 1.15\text{ MHz}$			55	ns
$I_{SW\_MAX}$	SW current limit		1.8	2	2.2	A
$R_{DSON}$	FET $R_{DSON}$	Pin-to-pin		240	400	m $\Omega$
$f_{SYNC}$	External SYNC frequency		300		2 200	kHz
$t_{SYNC\_ON\_MIN}$	External SYNC minimum on time <sup>(1)</sup>			150		ns
$t_{SYNC\_OFF\_MIN}$	External SYNC minimum off time <sup>(1)</sup>			150		ns

(1) This specification is not ensured by ATE.

## 6.11 Logic Interface Characteristics

$T_J = -40^{\circ}\text{C}$  to  $+125^{\circ}\text{C}$  (unless otherwise noted).

PARAMETER		TEST CONDITIONS	MIN	TYP	MAX	UNIT
<b>LOGIC INPUT VDDIO/EN</b>						
$V_{IL}$	Input low level				0.4	V
$V_{IH}$	Input high level		1.65			
$I_I$	Input current		-1	5	30	$\mu\text{A}$
<b>LOGIC INPUT SYNC/FSET, PWM</b>						
$V_{IL}$	Input low level			$0.2 \times V_{DDIO/EN}$		V
$V_{IH}$	Input high level		$0.8 \times V_{DDIO/EN}$			
$I_I$	Input current		-1		1	$\mu\text{A}$
<b>LOGIC OUTPUT FAULT</b>						
$V_{OL}$	Output low level	Pullup current 3 mA		0.3	0.5	V
$I_{LEAKAGE}$	Output leakage current	$V = 5.5\text{ V}$			1	$\mu\text{A}$

## 6.12 Typical Characteristics

Unless otherwise specified: D = NRVB460MFS, T = 25°C

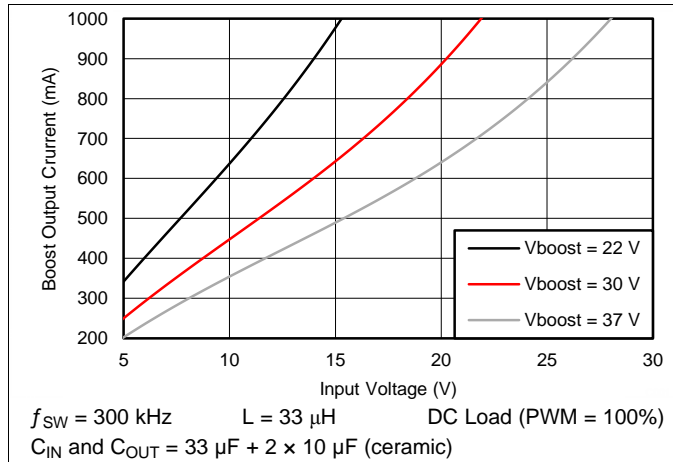

Figure 1. Maximum Boost Current

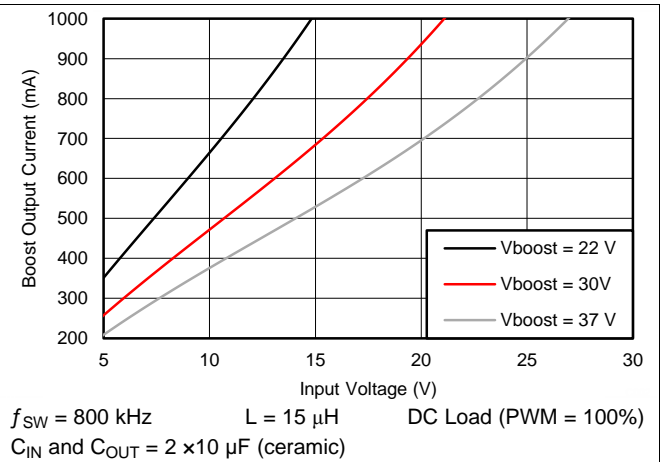

Figure 2. Maximum Boost Current

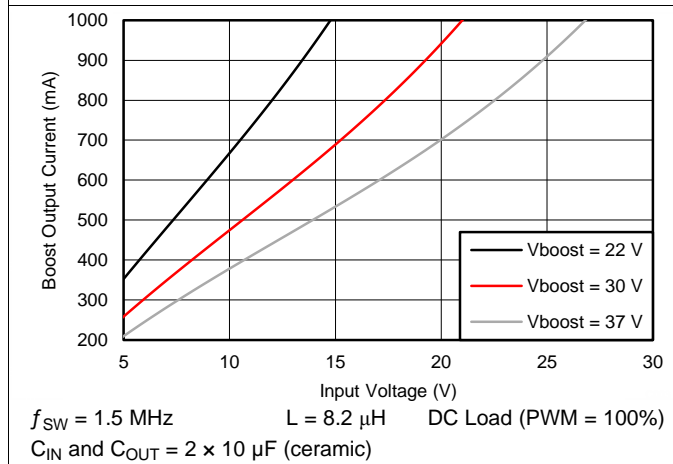

Figure 3. Maximum Boost Current

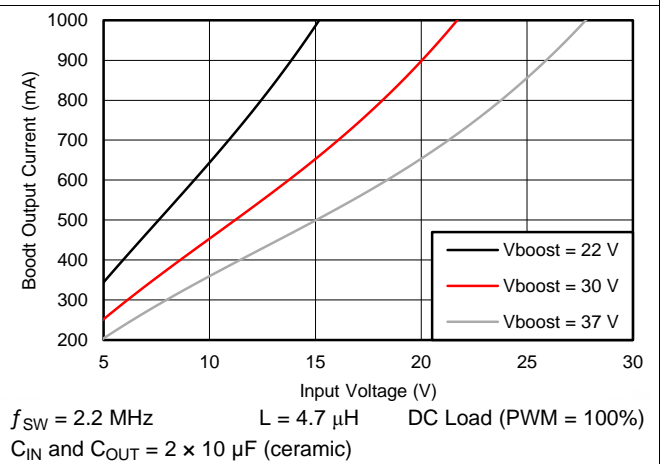

Figure 4. Maximum Boost Current

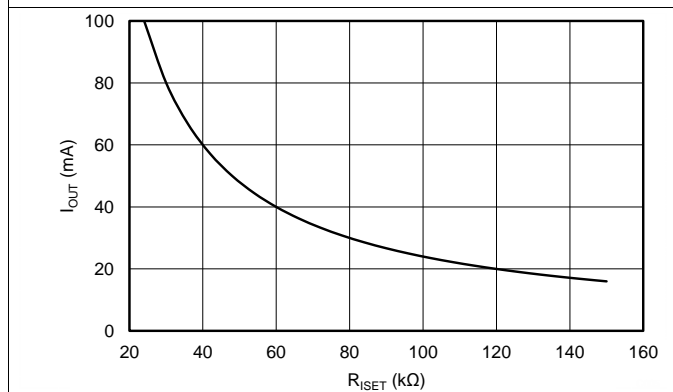

Figure 5. LED Current vs  $R_{ISET}$

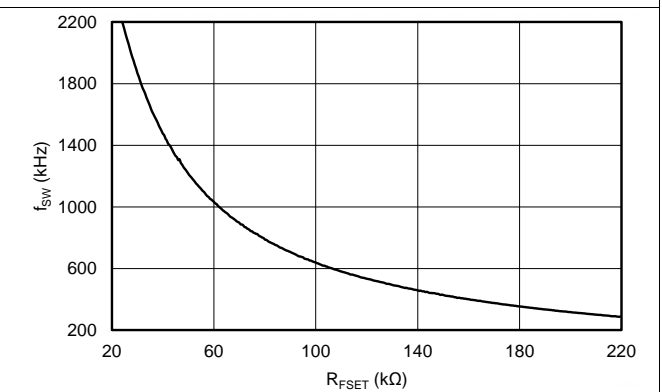
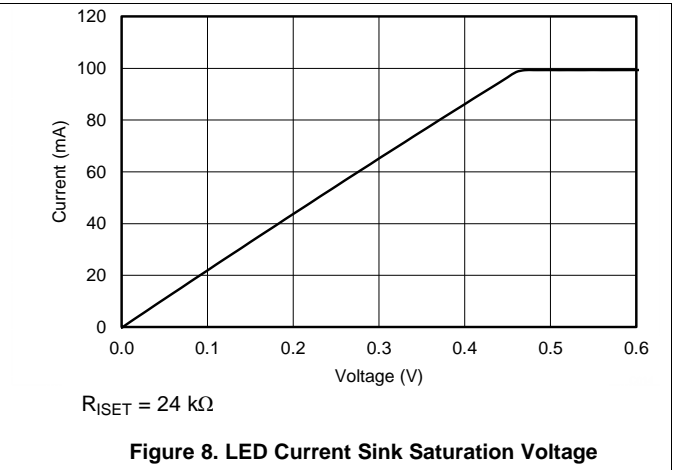
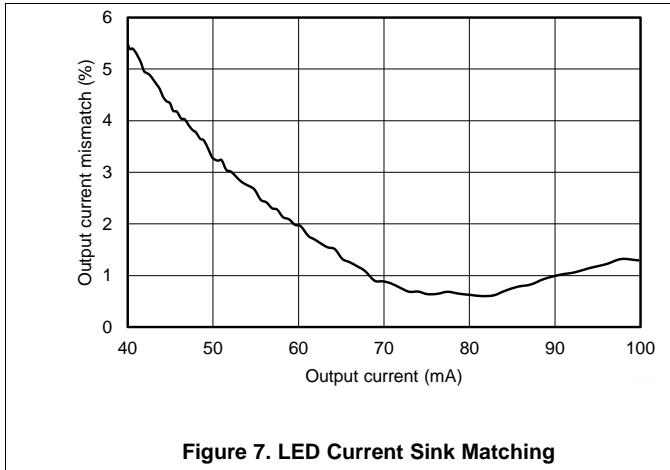

Figure 6. Boost Switching Frequency  $f_{SW}$  vs  $R_{FSET}$

**Typical Characteristics (continued)**

Unless otherwise specified: D = NRVB460MFS, T = 25°C



## 7 Detailed Description

### 7.1 Overview

The TPS61193 is a highly integrated LED driver for medium-sized LCD backlight applications. It includes a DC-DC with an integrated FET, supporting both boost and SEPIC modes, an internal LDO enabling direct connection to battery without need for a pre-regulated supply and three LED current sinks. The VDDIO/EN pin provides the supply voltage for digital IOs (PWM and SYNC inputs) and at the same time enables the device.

The switching frequency on the DC-DC converter is set by a resistor connected to the FSET pin. The maximum voltage of the DC-DC is set by a resistive divider connected to the FB pin. For the best efficiency the output voltage is adapted automatically to the minimum necessary level needed to drive the LED strings. This is done by monitoring LED output voltage drop in real time. For EMI reduction and control two optional features are available:

- Spread spectrum, which reduces EMI noise around the switching frequency and its harmonic frequencies
- DC-DC can be synchronized to an external frequency connected to SYNC pin

The three constant current sinks OUT1, OUT2, and OUT3 provide LED current up to 100 mA. Value for the current per OUT pin is set with a resistor connected to ISET pin. Current sinks that are not used must be connected to ground. Grounded current sink is disabled and excluded from adaptive voltage detection loop.

Brightness is controlled with the PWM input. Frequency range for the input PWM is from 100 Hz to 20 kHz. LED output PWM follows the input PWM so the output frequency is equal to the input frequency.

TPS61193 has extensive fault detection features :

- Open-string and shorted LED detections
  - LED fault detection prevents system overheating in case of open or short in some of the LED strings
- $V_{IN}$  input overvoltage protection
  - Threshold sensing from VIN pin
- $V_{IN}$  input undervoltage protection
  - Threshold sensing from VIN pin
- Thermal shutdown in case of die overtemperature

Fault condition is indicated through the FAULT output pin.

## 7.2 Functional Block Diagram

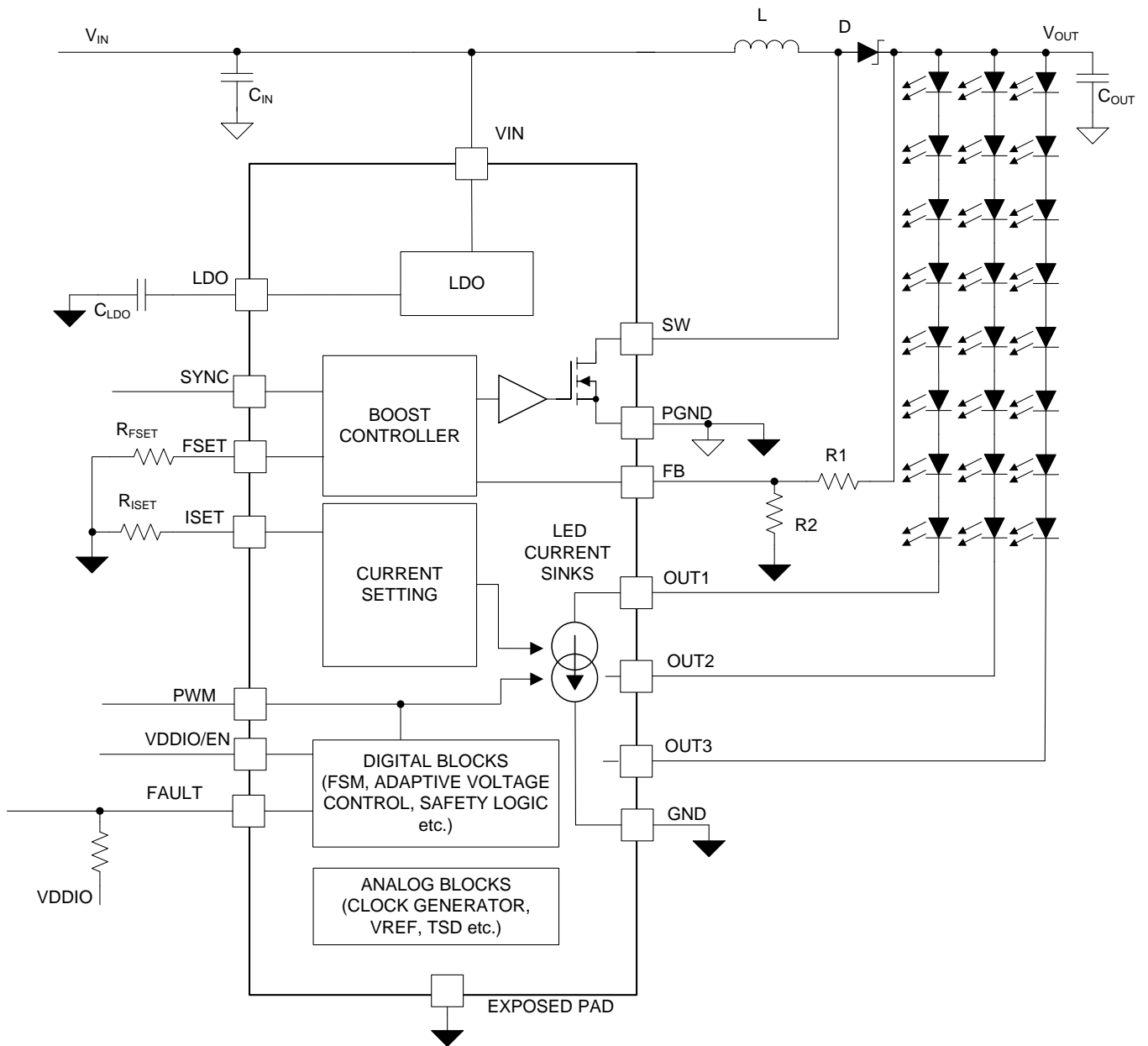

## 7.3 Feature Description

### 7.3.1 Integrated DC-DC Converter

The TPS61193 DC-DC converter generates supply voltage for the LEDs and can operate in boost mode or in SEPIC mode. The maximum output voltage  $V_{OUT\_MAX}$  is defined by an external resistive divider ( $R_1$ ,  $R_2$ ).

$V_{OUT\_MAX}$  voltage should be chosen based on the maximum voltage required for LED strings. Recommended maximum voltage is about 30% higher than maximum LED string voltage. DC-DC output voltage is adjusted automatically based on LED current sink headroom voltage. Maximum, minimum, and initial boost voltages can be calculated with Equation 1:

$$V_{BOOST} = \left( \frac{V_{BG}}{R_2} + K \times 0.0387 \right) \times R_1 + V_{BG}$$

where

- $V_{BG} = 1.2$  V
- $R_2$  recommended value is 130 k $\Omega$
- Resistor values are in k $\Omega$
- $K = 1$  for maximum adaptive boost voltage (typical)
- $K = 0$  for minimum adaptive boost voltage (typical)
- $K = 0.88$  for initial boost voltage (typical)

(1)

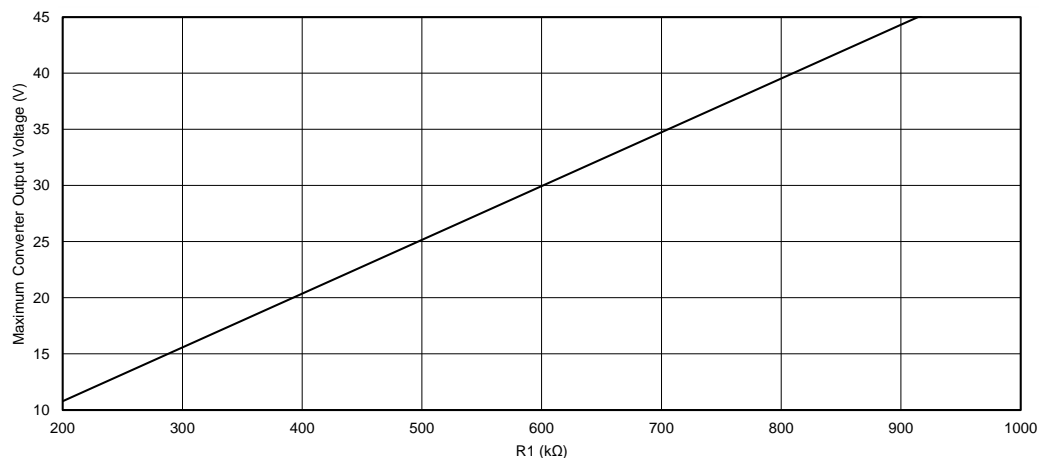

**Figure 9. Maximum Converter Output Voltage vs R1 Resistance**

Alternatively, a T-divider can be used if resistance less than 100 k $\Omega$  is required for the external resistive divider. Refer to [Using the TPS61193EVM and TPS61193-Q1EVM Evaluation Module](#) for details.

The converter is a current mode DC-DC converter, where the inductor current is measured and controlled with the feedback. Switching frequency is adjustable between 250 kHz and 2.2 MHz with  $R_{FSET}$  resistor as Equation 2:

$$f_{SW} = 67600 / (R_{FSET} + 6.4)$$

where

- $f_{SW}$  is switching frequency, kHz
- $R_{FSET}$  is frequency setting resistor, k $\Omega$

(2)

In most cases lower frequency has higher system efficiency. DC-DC internal parameters are chosen automatically according to the selected switching frequency (see Table 2) to ensure stability. In boost mode a 15-pF capacitor  $C_{FB}$  must be placed across resistor  $R_1$  when operating in 300-kHz to 500-kHz range (see [Typical Application for 3 LED Strings](#)). When operating in the 1.8-MHz to 2.2-MHz range  $C_{FB} = 4.7$  pF.

Feature Description (continued)

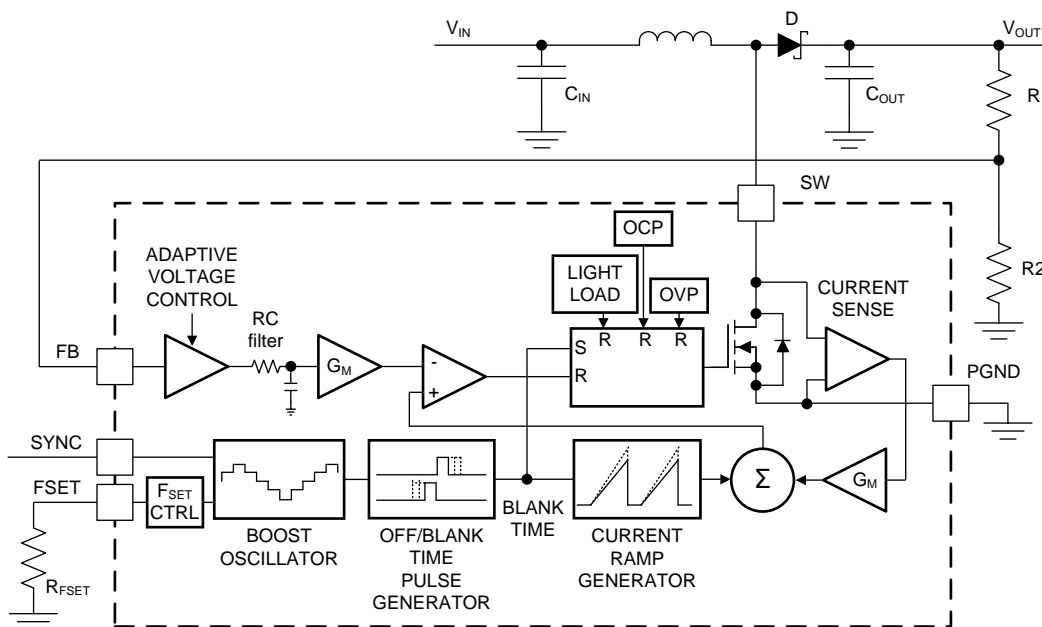

Figure 10. Boost Block Diagram

DC-DC can be driven by an external SYNC signal between 300 kHz and 2.2 MHz. If the external synchronization input disappears, DC-DC continues operation at the frequency defined by R<sub>FSET</sub> resistor. When external frequency disappears and SYNC pin level is low, converter continues operation without spread spectrum immediately. If SYNC remains high, converter continues switching with spread spectrum enabled after 256 μs.

External SYNC frequency must be 1.2 to 1.5 times higher than the frequency defined by R<sub>FSET</sub> resistor. Minimum frequency setting with R<sub>FSET</sub> is 250 kHz to support 300-kHz switching with external clock.

The optional spread spectrum feature (±3% from central frequency, 1-kHz modulation frequency) reduces EMI noise at the switching frequency and its harmonic frequencies. When external synchronization is used, spread spectrum is not available.

Table 1. DC-DC Synchronization Mode

SYNC PIN INPUT	MODE
Low	Spread spectrum disabled
High	Spread spectrum enabled
300 to 2200 kHz frequency	Spread spectrum disabled, external synchronization mode

Table 2. DC-DC Parameters<sup>(1)</sup>

RANGE	FREQUENCY (kHz)	TYPICAL INDUCTANCE (μH)	TYPICAL BOOST INPUT AND OUTPUT CAPACITORS (μF)	MINIMUM SWITCH OFF TIME (ns) <sup>(2)</sup>	BLANK TIME (ns)	CURRENT RAMP (A/s)	CURRENT RAMP DELAY (ns)
1	300 to 480	33	2 × 10 (cer.) + 33 (electr.)	150	95	24	550
2	480 to 1150	15	10 (cer.) + 33 (electr.)	60	95	43	300
3	1150 to 1650	10	3 × 10 (cer.)	40	95	79	0
4	1650 to 2200	4.7	3 × 10 (cer.)	40	70	145	0

(1) Parameters are for reference only

(2) Due to current sensing comparator delay the actual minimum off time is 6 ns (typical) longer than in the table.

The converter SW pin DC current is limited to 2 A (typical). To support short-term transient conditions the current limit is automatically increased to 2.5 A for a short period of 1.5 seconds when a 2-A limit is reached.

---

**NOTE**

Application condition where the 2-A limit is exceeded continuously is not allowed. In this case the current limit would be 2 A for 1.5 seconds followed by 2.5-A limit for 1.5 seconds, and this 3-second period repeats.

---

To keep switching voltage within safe levels there is a 48-V limit comparator in the event that FB loop is broken.

### 7.3.2 Internal LDO

The internal LDO regulator converts the input voltage at VIN to a 4.3-V output voltage for internal use. Connect a minimum of 1- $\mu$ F ceramic capacitor from LDO pin to ground, as close to the LDO pin as possible.

### 7.3.3 LED Current Sinks

#### 7.3.3.1 Output Configuration

TPS61193 detects LED output configuration during start-up. Any current sink output connected to ground is disabled and excluded from the adaptive voltage control of the DC-DC and fault detections.

#### 7.3.3.2 Current Setting

Maximum current for the LED outputs is controlled with external  $R_{\text{ISET}}$  resistor.  $R_{\text{ISET}}$  value for target maximum current can be calculated using [Equation 3](#):

$$R_{\text{ISET}} = 2342 / (I_{\text{OUT}} - 2.5)$$

where

- $R_{\text{ISET}}$  is current setting resistor,  $k\Omega$
  - $I_{\text{LED}}$  is output current per output, mA
- (3)

#### 7.3.3.3 Brightness Control

TPS61193 controls the brightness of the display with conventional PWM. Output PWM directly follows the input PWM. Input PWM frequency can be in the range of 100 Hz to 20 kHz.

### 7.3.4 Protection and Fault Detections

The TPS61193 has fault detection for LED open and short, VIN input overvoltage protection (VIN\_OVP), VIN undervoltage lockout (VIN\_UVLO), and thermal shutdown (TSD).

#### 7.3.4.1 Adaptive DC-DC Voltage Control and Functionality of LED Fault Comparators

Adaptive voltage control function adjusts the DC-DC output voltage to the minimum sufficient voltage for proper LED current sink operation. The current sink with highest  $V_F$  LED string is detected and DC-DC output voltage adjusted accordingly. DC-DC adaptive control voltage step size is defined by maximum voltage setting,  $V_{\text{STEP}} = (V_{\text{OUT\_MAX}} - V_{\text{OUT\_MIN}}) / 256$ . Periodic down pressure is applied to the target voltage to achieve better system efficiency.

Every LED current sink has 3 comparators for the adaptive DC-DC control and LED fault detections. Comparator outputs are filtered, filtering time is 1  $\mu$ s.

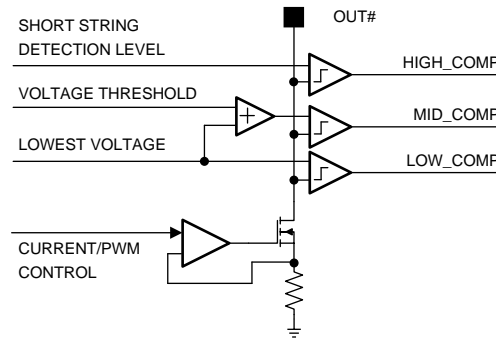

**Figure 11. Comparators for Adaptive Voltage Control and LED Fault Detection**

Figure 12 shows different cases which cause DC-DC voltage increase, decrease, or generate faults. In normal operation voltage at all the OUT# pins is between LOW\_COMP and MID\_COMP levels, and boost voltage stays constant. LOW\_COMP level is the minimum for proper LED current sink operation,  $1.1 \times V_{SAT} + 0.2 \text{ V}$  (typical). MID\_COMP level is  $1.1 \times V_{SAT} + 1.2 \text{ V}$  (typical) so typical headroom window is 1 V.

When voltage at all the OUT# pins increases above MID\_COMP level, DC-DC voltage adapts downwards.

When voltage at any of the OUT# pins falls below LOW\_COMP threshold, DC-DC voltage adapts upwards. In the condition where DC-DC voltage reaches the maximum and there are one or more outputs still below LOW\_COMP level, an open LED fault is detected.

HIGH\_COMP level, 6 V typical, is the threshold for shorted LED detection. When the voltage of one or more of the OUT# pins increases above HIGH\_COMP level and at least one of the other outputs is within the normal headroom window, shorted LED fault is detected.

**Figure 12. Protection and DC-DC Voltage Adaptation Algorithms**

### 7.3.4.2 Overview of the Fault/Protection Schemes

A summary of the TPS61193 fault detection behavior is shown in [Table 3](#). Detected faults (excluding LED open or short) cause device to enter FAULT\_RECOVERY state. In FAULT\_RECOVERY the DC-DC and LED current sinks of the device are disabled, and the FAULT pin is pulled low. The device recovers automatically and enters normal operating mode (ACTIVE) after a recovery time of 100 ms if the fault condition has disappeared. When recovery is successful, FAULT pin is released.

If a LED fault is detected, the device continues normal operation and only the faulty string is disabled. The fault is indicated via the FAULT pin which can be released by toggling VDDIO/EN pin low for a short period of 2  $\mu$ s to 20  $\mu$ s. LEDs are turned off for this period but the device stays in ACTIVE mode. If VDDIO/EN is low longer, the device goes to STANDBY and restarts when EN goes high again.

**Table 3. Fault Detections**

FAULT/ PROTECTION	FAULT NAME	THRESHOLD	FAULT PIN	FAULT RECOVERY STATE	ACTION
VIN overvoltage protection	VIN_OVP	1. $V_{IN} > 42\text{ V}$ 2. $V_{OUT} > V_{SET\_DCDC} + 6..10\text{ V}$ . $V_{SET\_DCDC}$ is voltage value defined by logic during adaptation	Yes	Yes	1. Overvoltage is monitored from the beginning of soft start. Fault is detected if the duration of overvoltage condition is 100 $\mu$ s minimum. 2. Overvoltage is monitored from the beginning of normal operation (ACTIVE mode). Fault is detected if over-voltage condition duration is 560 ms minimum ( $t_{filter}$ ). After the first fault, detection filter time is reduced to 50 ms for following recovery cycles. When the device recovers and has been in ACTIVE mode for 160 ms, filter time is increased back to 560 ms .
VIN undervoltage lockout	VIN_UVLO	Falling 3.9 V Rising 4 V	Yes	Yes	Detects undervoltage condition at VIN pin. Sensed in all operating modes. Fault is detected if undervoltage condition duration is 100 $\mu$ s minimum.
Open LED fault	OPEN_LED	LOW_COMP threshold	Yes	No	Detected if the voltage of one or more current sinks is below threshold level, and DC-DC adaptive control has reached maximum voltage. Open string is removed from the DC-DC voltage control loop and current sink is disabled. Fault pin is released by toggling VDDIO/EN pin. If VDDIO/EN is low for a period of 2 $\mu$ s to 20 $\mu$ s, LEDs are turned off for this period but device stays ACTIVE. If VDDIO/EN is low longer, device goes to STANDBY and restarts when EN goes high again.
Shorted LED fault	SHORT_LED	Shorted string detection level 6 V	Yes	No	Detected if the voltage of one or more current sinks is above shorted string detection level and at least one OUTx voltage is within headroom window. Shorted string is removed from the DC-DC voltage control loop and current sink is disabled. Fault pin is released by toggling VDDIO/EN pin. If VDDIO/EN is low for a period of 2...20 $\mu$ s, LEDs are turned off for this period but device stays ACTIVE. If VDDIO/EN is low longer, device goes to STANDBY and restarts when EN goes high again..
Thermal protection	TSD	165°C Thermal shutdown hysteresis 20°C	Yes	Yes	Thermal shutdown is monitored from the beginning of soft start. Die temperature must decrease by 20°C for device to recover.

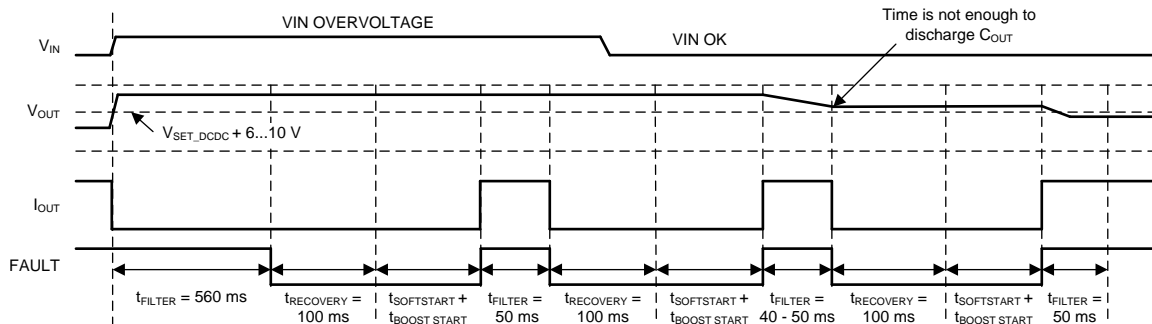

Figure 13. VIN Overvoltage Protection (DC-DC OVP)

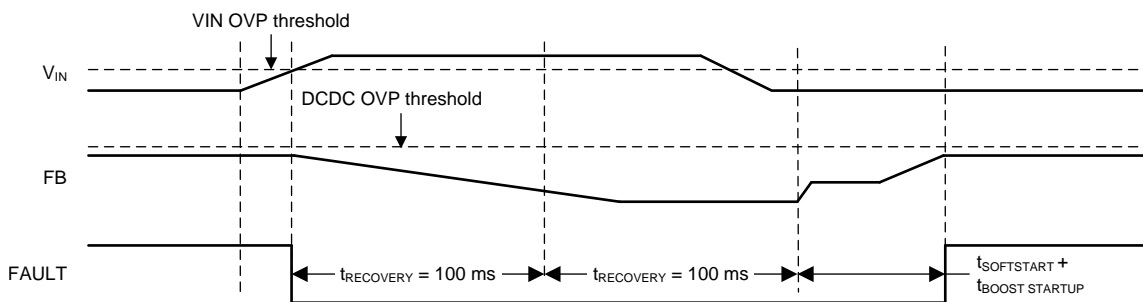

Figure 14. VIN Overvoltage Protection (VIN OVP)

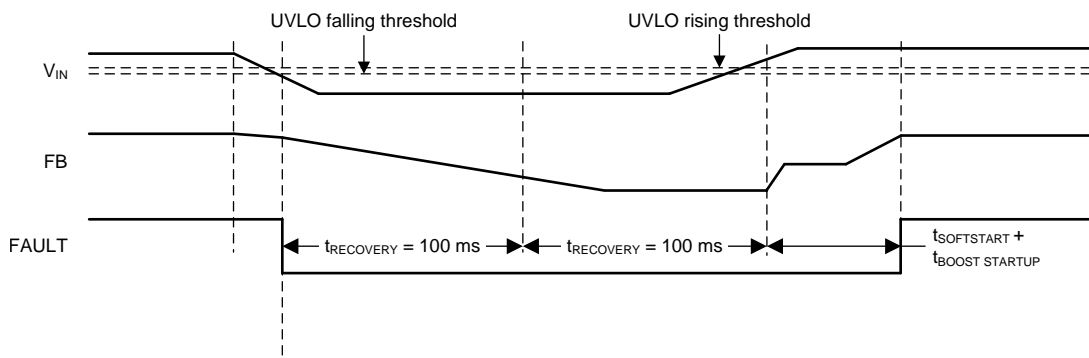
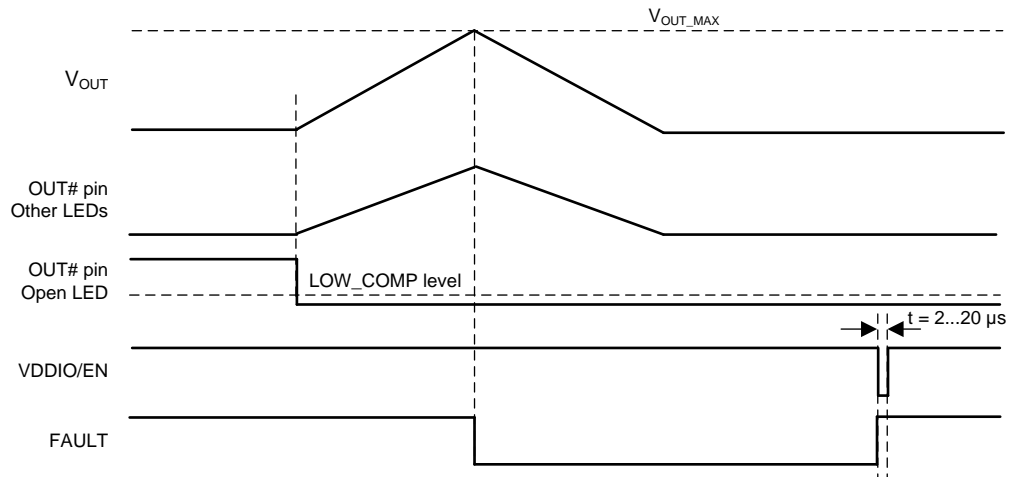
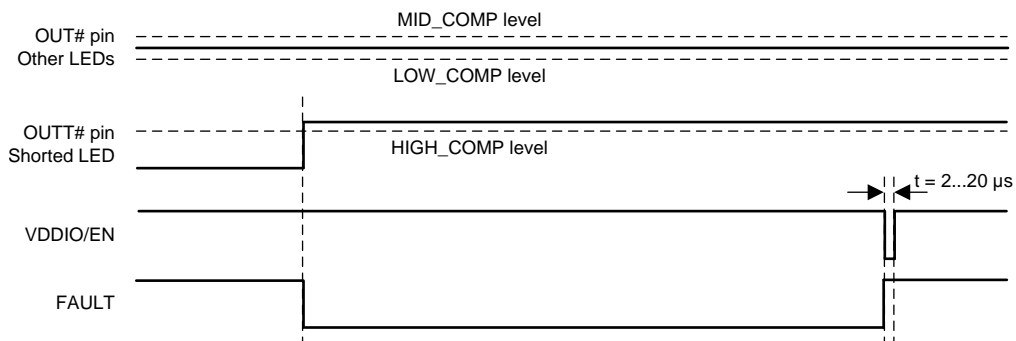

Figure 15. VIN Undervoltage Lockout

**Figure 16. LED Open Fault**

**Figure 17. LED Short Fault**

## 7.4 Device Functional Modes

### 7.4.1 Device States

The TPS61193 enters STANDBY mode when the internal LDO output rises above the power-on reset level,  $V_{LDO} > V_{POR}$ . In STANDBY mode the device is able to detect VDDIO/EN signal. When VDDIO/EN is pulled high, the device powers up. After start LED outputs are sensed to detect grounded outputs. Grounded outputs are disabled and excluded from the adaptive voltage control loop of the DC-DC.

If a fault condition is detected, the device enters FAULT\_RECOVERY state. Faults that cause the device to enter FAULT\_RECOVERY are listed in [Table 3](#). When LED open or short is detected, the faulty string is disabled, but device stays in ACTIVE mode.

Device Functional Modes (continued)

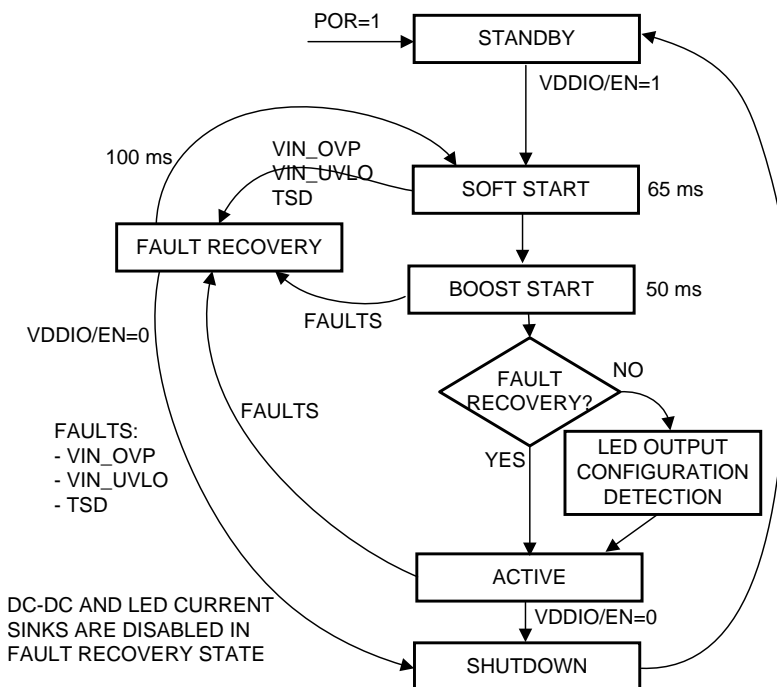

Figure 18. State Diagram

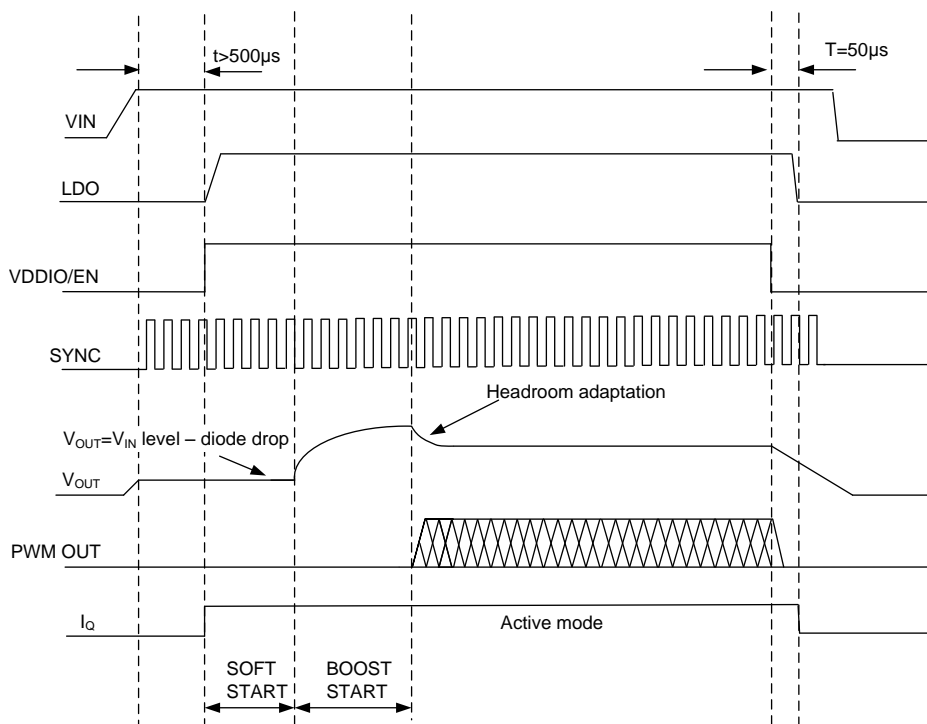

Figure 19. Timing Diagram for the Typical Start-Up and Shutdown

## 8 Application and Implementation

### NOTE

Information in the following applications sections is not part of the TI component specification, and TI does not warrant its accuracy or completeness. TI's customers are responsible for determining suitability of components for their purposes. Customers should validate and test their design implementation to confirm system functionality.

### 8.1 Application Information

The TPS61193 supports input voltage range from 4.5 V to 40 V. Device internal circuitry is powered from the integrated LDO.

The TPS61193 uses a simple four-wire control:

- VDDIO/EN for enable
- PWM input for brightness control
- SYNC pin for boost synchronisation (optional)
- FAULT output to indicate fault condition (optional)

### 8.2 Typical Applications

#### 8.2.1 Typical Application for 3 LED Strings

Figure 20 shows the typical application for TPS61193 which supports 3 LED strings with maximum current 100 mA, with a boost switching frequency of 300 kHz.

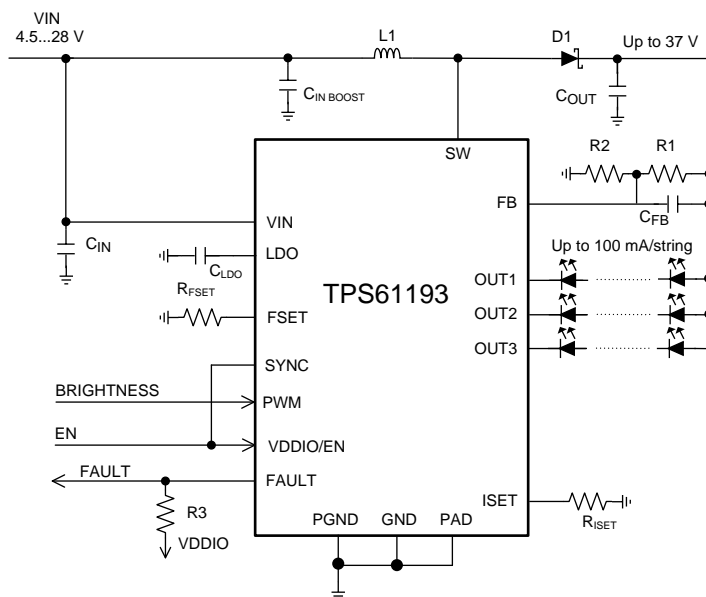

Figure 20. Three Strings 100 mA/String Configuration

## Typical Applications (continued)

### 8.2.1.1 Design Requirements

DESIGN PARAMETER	VALUE
V <sub>IN</sub> voltage range	4.5 V – 28 V
LED string	3P8S LEDs (30 V)
LED string current	100 mA
Maximum boost voltage	37 V
Boost switching frequency	300 kHz
External boost sync	not used
Boost spread spectrum	enabled
L1	33 μH
C <sub>IN</sub>	100 μF, 50 V
C <sub>IN BOOST</sub>	2 × (10-μF, 50-V ceramic) + 33-μF, 50-V electrolytic
C <sub>OUT</sub>	2 × (10-μF, 50-V ceramic) + 33-μF, 50-V electrolytic
C <sub>FB</sub>	15 pF
C <sub>LDO</sub>	1 μF, 10 V
R <sub>ISET</sub>	24 kΩ
R <sub>FSET</sub>	210 kΩ
R1	750 kΩ
R2	130 kΩ
R3	10 kΩ

### 8.2.1.2 Detailed Design Procedure

#### 8.2.1.2.1 Inductor Selection

There are two main considerations when choosing an inductor; the inductor must not saturate, and the inductor current ripple must be small enough to achieve the desired output voltage ripple. Different saturation current rating specifications are followed by different manufacturers so attention must be given to details. Saturation current ratings are typically specified at 25°C. However, ratings at the maximum ambient temperature of application should be requested from the manufacturer. Shielded inductors radiate less noise and are preferred. The saturation current must be greater than the sum of the maximum load current, and the worst case average-to-peak inductor current. Equation 4 shows the worst case conditions

$$I_{SAT} > \frac{I_{OUTMAX}}{D'} + I_{RIPPLE} \quad \text{For Boost}$$

$$\text{Where } I_{RIPPLE} = \frac{(V_{OUT} - V_{IN})}{(2 \times L \times f)} \times \frac{V_{IN}}{V_{OUT}}$$

$$\text{Where } D = \frac{(V_{OUT} - V_{IN})}{(V_{OUT})} \text{ and } D' = (1 - D)$$

- I<sub>RIPPLE</sub> - peak inductor current
- I<sub>OUTMAX</sub> - maximum load current
- V<sub>IN</sub> - minimum input voltage in application
- L - min inductor value including worst case tolerances
- f - minimum switching frequency
- V<sub>OUT</sub> - output voltage
- D - Duty Cycle for CCM Operation

(4)

As a result, the inductor should be selected according to the I<sub>SAT</sub>. A more conservative and recommended approach is to choose an inductor that has a saturation current rating greater than the maximum current limit. A saturation current rating of at least 2.5 A is recommended for most applications. See Table 2 for recommended inductance value for the different switching frequency ranges. The inductor's resistance should be less than 300 mΩ for good efficiency.

See detailed information in *Understanding Boost Power Stages in Switch Mode Power Supplies. Power Stage Designer™ Tool* can be used for the boost calculation: <http://www.ti.com/tool/powerstage-designer>.

### 8.2.1.2.2 Output Capacitor Selection

A ceramic capacitor with  $2 \times V_{MAX\_BOOST}$  or more voltage rating is recommended for the output capacitor. The DC-bias effect can reduce the effective capacitance by up to 80%, which needs to be considered in capacitance value selection. Capacitance recommendations for different switching frequencies are shown in Table 2. To minimize audible noise of ceramic capacitors their physical size should typically be minimized.

### 8.2.1.2.3 Input Capacitor Selection

A ceramic capacitor with  $2 \times V_{IN\_MAX}$  or more voltage rating is recommended for the input capacitor. The DC-bias effect can reduce the effective capacitance by up to 80%, which needs to be considered in capacitance value selection. Capacitance recommendations for different boost switching frequencies are shown in Table 2.

### 8.2.1.2.4 LDO Output Capacitor

A ceramic capacitor with at least 10-V voltage rating is recommended for the output capacitor of the LDO. The DC-bias effect can reduce the effective capacitance by up to 80%, which needs to be considered in capacitance value selection. Typically a 1- $\mu$ F capacitor is sufficient.

### 8.2.1.2.5 Diode

A Schottky diode should be used for the boost output diode. Do not use ordinary rectifier diodes because slow switching speeds and long recovery times degrade the efficiency and the load regulation. Diode rating for peak repetitive current should be greater than inductor peak current (up to 3 A) to ensure reliable operation in boost mode. Average current rating should be greater than the maximum output current. Schottky diodes with a low forward drop and fast switching speeds are ideal for increasing efficiency. Choose a reverse breakdown voltage of the Schottky diode significantly larger than the output voltage.

## 8.2.1.3 Application Curves

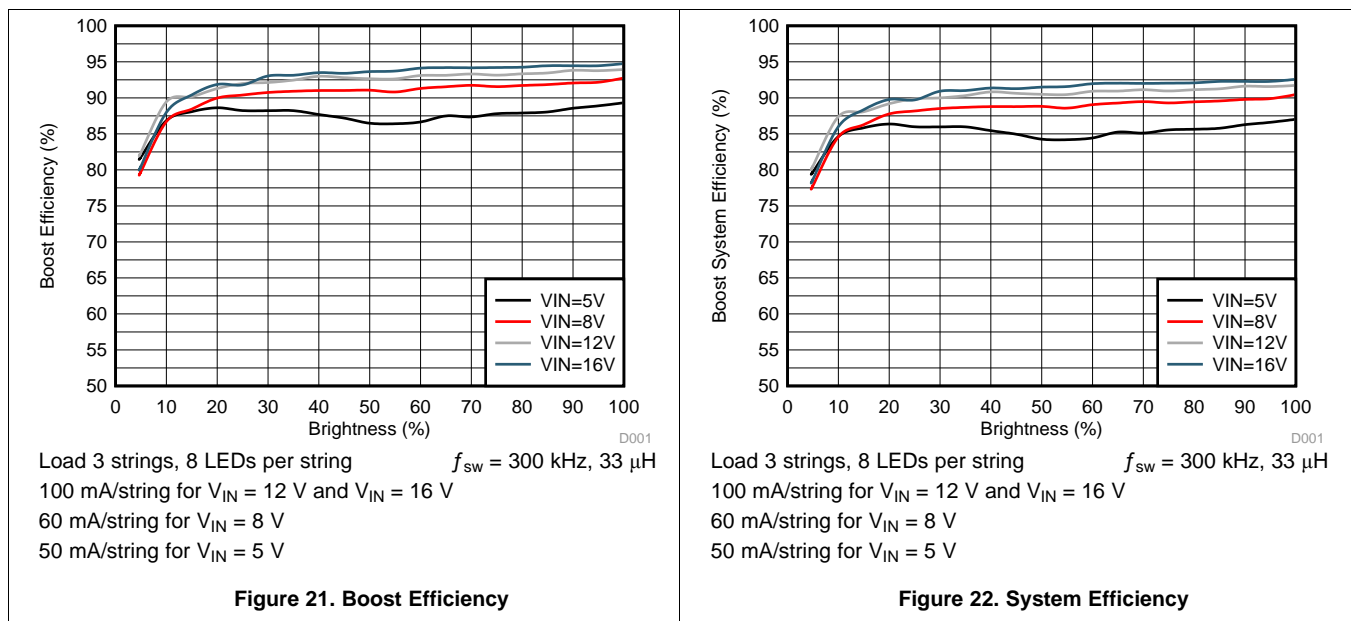



### 8.2.2.1 Design Requirements

DESIGN PARAMETER	VALUE
$V_{IN}$ voltage range	4.5 V – 30 V
LED string	3P2S LEDs (7.2 V)
LED string current	100 mA
Maximum output voltage	10 V
SEPIC switching frequency	2.2 MHz
External sync for SEPIC	used
Spread spectrum	Internal spread spectrum disabled (external sync used)
L1, L2	10 $\mu$ H
$C_{IN}$	10 $\mu$ F 50 V
$C_{IN\ SEPIC}$	2 $\times$ 10- $\mu$ F, 50-V ceramic + 33 $\mu$ F 50-V electrolytic
C1	10- $\mu$ F 50-V ceramic
$C_{OUT}$	2 $\times$ 10- $\mu$ F, 50-V ceramic + 33 $\mu$ F 50-V electrolytic
$C_{LDO}$	1 $\mu$ F, 10 V
$R_{ISET}$	24 k $\Omega$
$R_{FSET}$	24 k $\Omega$
R1	184 k $\Omega$
R2	130 k $\Omega$
R3	10 k $\Omega$

### 8.2.2.2 Detailed Design Procedure

In SEPIC mode the maximum voltage at the SW pin is equal to the sum of the input voltage and the output voltage. Because of this, the maximum sum of input and output voltage must be limited below 50 V. See [Detailed Design Procedure](#) for general external component guidelines. Main differences of SEPIC compared to boost are described below.

*Power Stage Designer™ Tool* can be used for modeling SEPIC behavior: <http://www.ti.com/tool/powerstage-designer>. For detailed explanation on SEPIC see Texas Instruments Analog Applications Journal [Designing DC/DC Converters Based on SEPIC Topology](#).

#### 8.2.2.2.1 Inductor

In SEPIC mode, currents flowing through the coupled inductors or the two separate inductors L1 and L2 are the input current and output current, respectively. Values can be calculated using *Power Stage Designer™ Tool* or using equations in [Designing DC/DC Converters Based on SEPIC Topology](#).

#### 8.2.2.2.2 Diode

In SEPIC mode diode peak current is equal to the sum of input and output currents. Diode rating for peak repetitive current should be greater than SW pin current limit (up to 3 A for transients) to ensure reliable operation in boost mode. Average current rating should be greater than the maximum output current. Diode voltage rating must be higher than sum of input and output voltages.

#### 8.2.2.2.3 Capacitor C1

Ti recommends a ceramic capacitor with low ESR. Diode voltage rating must be higher than maximum input voltage.

### 8.2.2.3 Application Curves

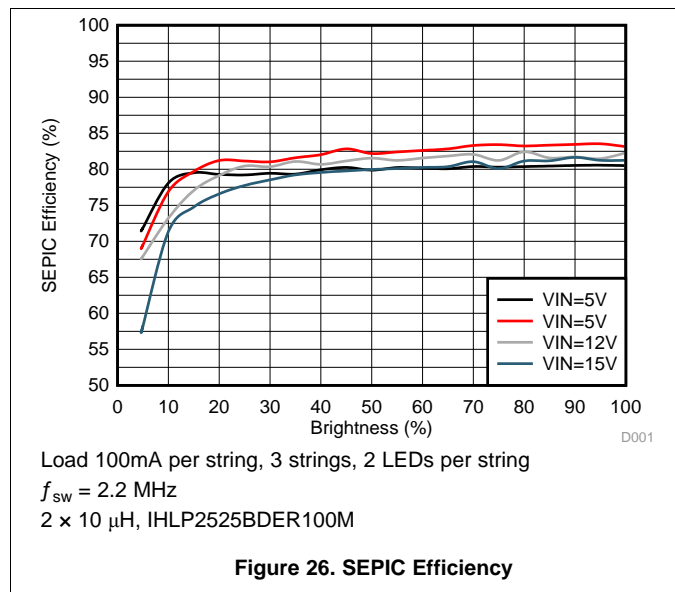

Figure 26. SEPIC Efficiency

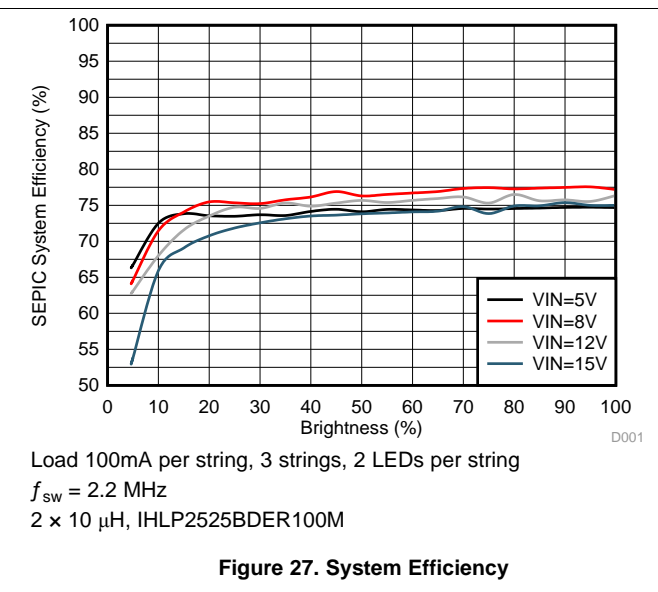

Figure 27. System Efficiency

## 9 Power Supply Recommendations

The resistance of the input supply rail must be low enough so that the input current transient does not cause too high drop at TPS61193 VIN pin. If the input supply is connected by using long wires additional bulk capacitance may be required in addition to the ceramic bypass capacitors in the  $V_{IN}$  line.

## 10 Layout

### 10.1 Layout Guidelines

Figure 28 is a layout recommendation for TPS61193 used to demonstrate the principles of a good layout. This layout can be adapted to the actual application layout if or where possible. It is important that all boost components are close to the chip, and the high current traces must be wide enough. By placing boost components on one side of the chip it is easy to keep the ground plane intact below the high current paths. This way other chip pins can be routed more easily without splitting the ground plane. Bypass LDO capacitor must as close as possible to the device.

Here are some main points to help the PCB layout work:

- Current loops need to be minimized:
  - For low frequency the minimal current loop can be achieved by placing the boost components as close as possible to the SW and PGND pins. Input and output capacitor grounds must be close to each other to minimize current loop size.
  - Minimal current loops for high frequencies can be achieved by making sure that the ground plane is intact under the current traces. High-frequency return currents find a route with minimum impedance, which is the route with minimum loop area, not necessarily the shortest path. Minimum loop area is formed when return current flows just under the *positive* current route in the ground plane, if the ground plane is intact under the route.
- The GND plane must be intact under the high current boost traces to provide shortest possible return path and smallest possible current loops for high frequencies.
- Current loops when the boost switch is conducting and not conducting must be on the same direction in optimal case.
- Inductors must be placed so that the current flows in the same direction as in the current loops. Rotating inductor 180° changes current direction.
- Use separate power and noise-free grounds. Power ground is used for boost converter return current and noise-free ground for more sensitive signals, such as LDO bypass capacitor grounding as well as grounding the GND pin of the device.
- Boost output feedback voltage to LEDs must be taken out *after* the output capacitors, not straight from the diode cathode.
- Place LDO 1- $\mu$ F bypass capacitor as close as possible to the LDO pin.
- Input and output capacitors require strong grounding (wide traces, many vias to GND plane).
- If two output capacitors are used they must have symmetrical layout to get both capacitors working ideally.
- Output ceramic capacitors have a DC-bias effect. If the output capacitance is too low, it can cause boost to become unstable on some loads, and this increases EMI. DC-bias characteristics should be obtained from the component manufacturer; they are not taken into account on component tolerance. TI recommends X5R/X7R capacitors.

## 10.2 Layout Example

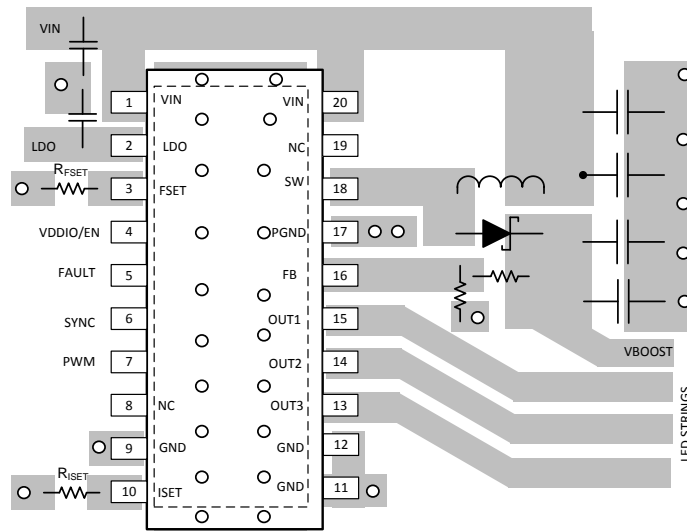

Figure 28. TPS61193 Boost Layout

## 11 Device and Documentation Support

### 11.1 Device Support

#### 11.1.1 Development Support

Power Stage Designer™ Tool can be used for both boost and SEPIC: <http://www.ti.com/tool/powerstage-designer>

### 11.2 Documentation Support

#### 11.2.1 Related Documentation

For related documentation see the following:

- 
- [PowerPAD™ Thermally Enhanced Package](#)
- [Understanding Boost Power Stages in Switch Mode Power Supplies](#)
- [Designing DC-DC Converters Based on SEPIC Topology](#)

### 11.3 Receiving Notification of Documentation Updates

To receive notification of documentation updates, navigate to the device product folder on ti.com. In the upper right corner, click on *Alert me* to register and receive a weekly digest of any product information that has changed. For change details, review the revision history included in any revised document.

### 11.4 Community Resources

The following links connect to TI community resources. Linked contents are provided "AS IS" by the respective contributors. They do not constitute TI specifications and do not necessarily reflect TI's views; see TI's [Terms of Use](#).

**TI E2E™ Online Community** *TI's Engineer-to-Engineer (E2E) Community*. Created to foster collaboration among engineers. At e2e.ti.com, you can ask questions, share knowledge, explore ideas and help solve problems with fellow engineers.

**Design Support** *TI's Design Support* Quickly find helpful E2E forums along with design support tools and contact information for technical support.

### 11.5 Trademarks

Power Stage Designer, E2E are trademarks of Texas Instruments. All other trademarks are the property of their respective owners.

### 11.6 Electrostatic Discharge Caution



These devices have limited built-in ESD protection. The leads should be shorted together or the device placed in conductive foam during storage or handling to prevent electrostatic damage to the MOS gates.

### 11.7 Glossary

[SLYZ022](#) — *TI Glossary*.

This glossary lists and explains terms, acronyms, and definitions.

## 12 Mechanical, Packaging, and Orderable Information

The following pages include mechanical, packaging, and orderable information. This information is the most current data available for the designated devices. This data is subject to change without notice and revision of this document. For browser-based versions of this data sheet, refer to the left-hand navigation.

**PACKAGING INFORMATION**

Orderable Device	Status (1)	Package Type	Package Drawing	Pins	Package Qty	Eco Plan (2)	Lead/Ball Finish (6)	MSL Peak Temp (3)	Op Temp (°C)	Device Marking (4/5)	Samples
TPS61193PWPR	ACTIVE	HTSSOP	PWP	20	2000	Green (RoHS & no Sb/Br)	CU NIPDAU	Level-2-260C-1 YEAR	-40 to 85	TPS61193	<a href="#">Samples</a>

(1) The marketing status values are defined as follows:

**ACTIVE:** Product device recommended for new designs.

**LIFEBUY:** TI has announced that the device will be discontinued, and a lifetime-buy period is in effect.

**NRND:** Not recommended for new designs. Device is in production to support existing customers, but TI does not recommend using this part in a new design.

**PREVIEW:** Device has been announced but is not in production. Samples may or may not be available.

**OBSOLETE:** TI has discontinued the production of the device.

(2) **RoHS:** TI defines "RoHS" to mean semiconductor products that are compliant with the current EU RoHS requirements for all 10 RoHS substances, including the requirement that RoHS substance do not exceed 0.1% by weight in homogeneous materials. Where designed to be soldered at high temperatures, "RoHS" products are suitable for use in specified lead-free processes. TI may reference these types of products as "Pb-Free".

**RoHS Exempt:** TI defines "RoHS Exempt" to mean products that contain lead but are compliant with EU RoHS pursuant to a specific EU RoHS exemption.

**Green:** TI defines "Green" to mean the content of Chlorine (Cl) and Bromine (Br) based flame retardants meet JS709B low halogen requirements of <=1000ppm threshold. Antimony trioxide based flame retardants must also meet the <=1000ppm threshold requirement.

(3) MSL, Peak Temp. - The Moisture Sensitivity Level rating according to the JEDEC industry standard classifications, and peak solder temperature.

(4) There may be additional marking, which relates to the logo, the lot trace code information, or the environmental category on the device.

(5) Multiple Device Markings will be inside parentheses. Only one Device Marking contained in parentheses and separated by a "~" will appear on a device. If a line is indented then it is a continuation of the previous line and the two combined represent the entire Device Marking for that device.

(6) Lead/Ball Finish - Orderable Devices may have multiple material finish options. Finish options are separated by a vertical ruled line. Lead/Ball Finish values may wrap to two lines if the finish value exceeds the maximum column width.

**Important Information and Disclaimer:**The information provided on this page represents TI's knowledge and belief as of the date that it is provided. TI bases its knowledge and belief on information provided by third parties, and makes no representation or warranty as to the accuracy of such information. Efforts are underway to better integrate information from third parties. TI has taken and continues to take reasonable steps to provide representative and accurate information but may not have conducted destructive testing or chemical analysis on incoming materials and chemicals. TI and TI suppliers consider certain information to be proprietary, and thus CAS numbers and other limited information may not be available for release.

In no event shall TI's liability arising out of such information exceed the total purchase price of the TI part(s) at issue in this document sold by TI to Customer on an annual basis.

**OTHER QUALIFIED VERSIONS OF TPS61193 :**

- Automotive: [TPS61193-Q1](#)

NOTE: Qualified Version Definitions:

- Automotive - Q100 devices qualified for high-reliability automotive applications targeting zero defects

## TAPE AND REEL INFORMATION



### QUADRANT ASSIGNMENTS FOR PIN 1 ORIENTATION IN TAPE



\*All dimensions are nominal

Device	Package Type	Package Drawing	Pins	SPQ	Reel Diameter (mm)	Reel Width W1 (mm)	A0 (mm)	B0 (mm)	K0 (mm)	P1 (mm)	W (mm)	Pin1 Quadrant
TPS61193PWPR	HTSSOP	PWP	20	2000	330.0	16.4	6.95	7.1	1.6	8.0	16.0	Q1

**TAPE AND REEL BOX DIMENSIONS**

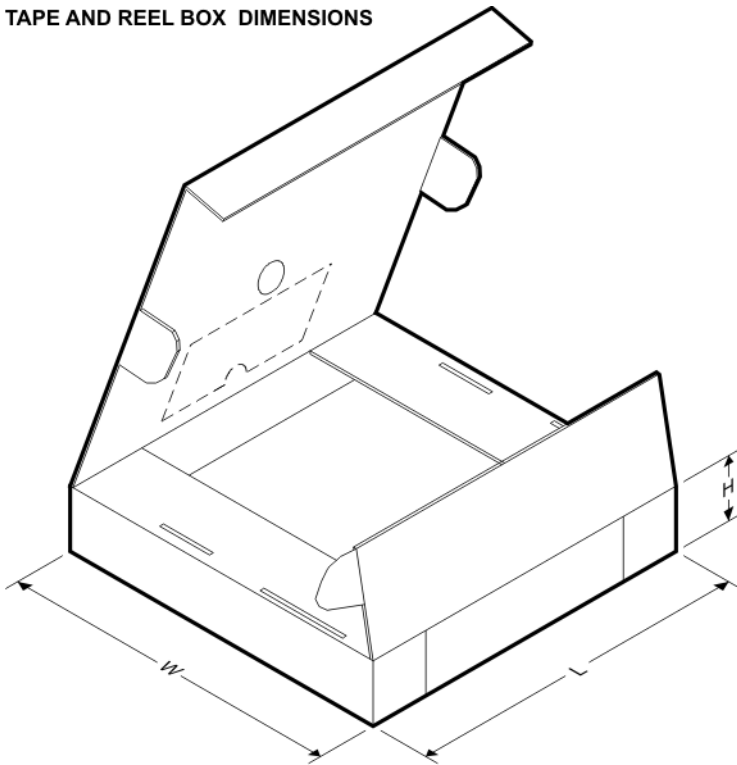

\*All dimensions are nominal

Device	Package Type	Package Drawing	Pins	SPQ	Length (mm)	Width (mm)	Height (mm)
TPS61193PWPR	HTSSOP	PWP	20	2000	367.0	367.0	38.0

# MECHANICAL DATA

PWP (R-PDSO-G20)

PowerPAD™ PLASTIC SMALL OUTLINE

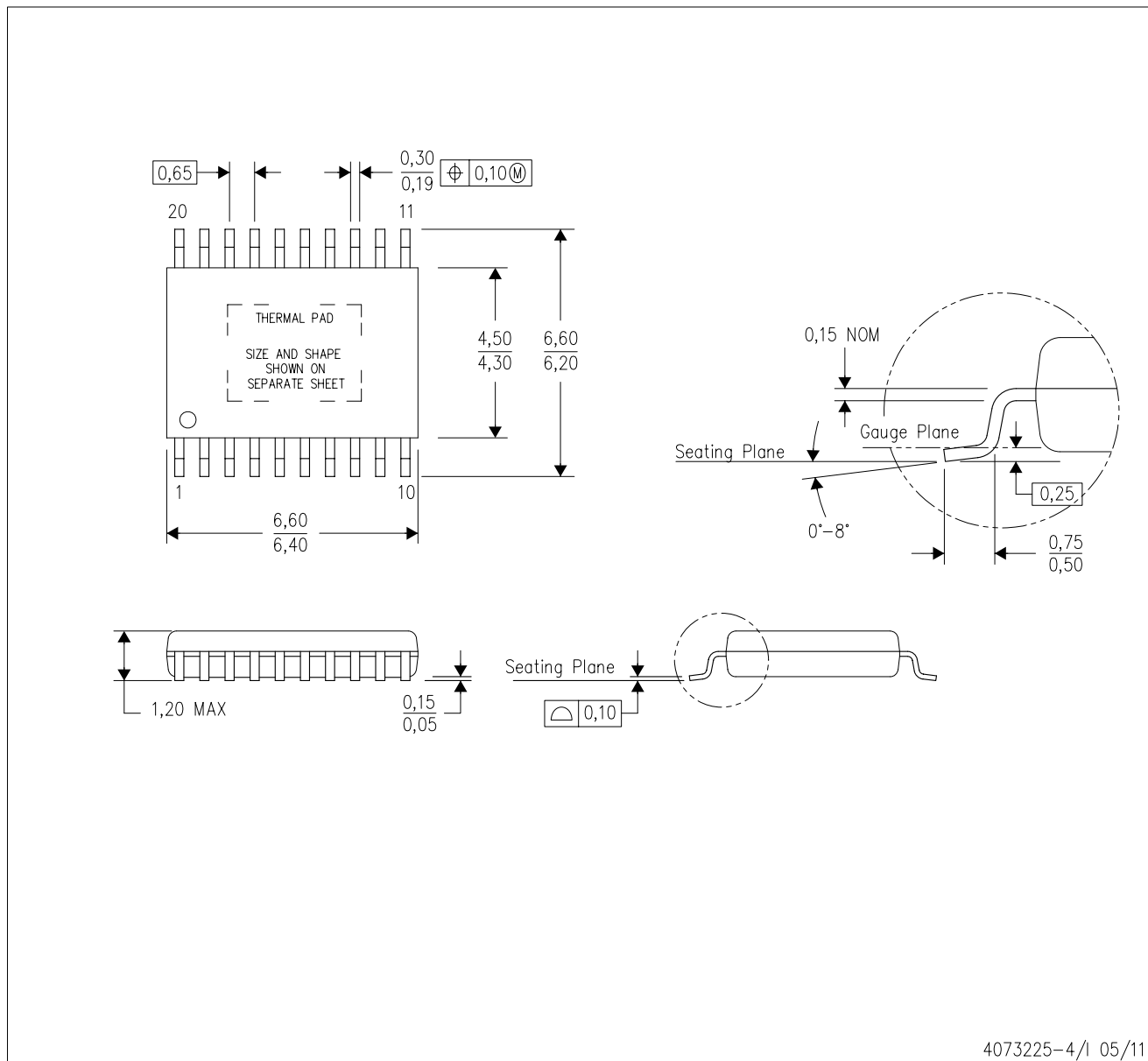

4073225-4/1 05/11

- NOTES:
- All linear dimensions are in millimeters.
  - This drawing is subject to change without notice.
  - Body dimensions do not include mold flash or protrusions. Mold flash and protrusion shall not exceed 0.15 per side.
  - This package is designed to be soldered to a thermal pad on the board. Refer to Technical Brief, PowerPad Thermally Enhanced Package, Texas Instruments Literature No. SLMA002 for information regarding recommended board layout. This document is available at [www.ti.com](http://www.ti.com) <<http://www.ti.com>>.
  - See the additional figure in the Product Data Sheet for details regarding the exposed thermal pad features and dimensions.
  - Falls within JEDEC MO-153

PowerPAD is a trademark of Texas Instruments.

# THERMAL PAD MECHANICAL DATA

## PWP (R-PDSO-G20) PowerPAD™ SMALL PLASTIC OUTLINE

### THERMAL INFORMATION

This PowerPAD™ package incorporates an exposed thermal pad that is designed to be attached to a printed circuit board (PCB). The thermal pad must be soldered directly to the PCB. After soldering, the PCB can be used as a heatsink. In addition, through the use of thermal vias, the thermal pad can be attached directly to the appropriate copper plane shown in the electrical schematic for the device, or alternatively, can be attached to a special heatsink structure designed into the PCB. This design optimizes the heat transfer from the integrated circuit (IC).

For additional information on the PowerPAD package and how to take advantage of its heat dissipating abilities, refer to Technical Brief, PowerPAD Thermally Enhanced Package, Texas Instruments Literature No. SLMA002 and Application Brief, PowerPAD Made Easy, Texas Instruments Literature No. SLMA004. Both documents are available at [www.ti.com](http://www.ti.com).

The exposed thermal pad dimensions for this package are shown in the following illustration.

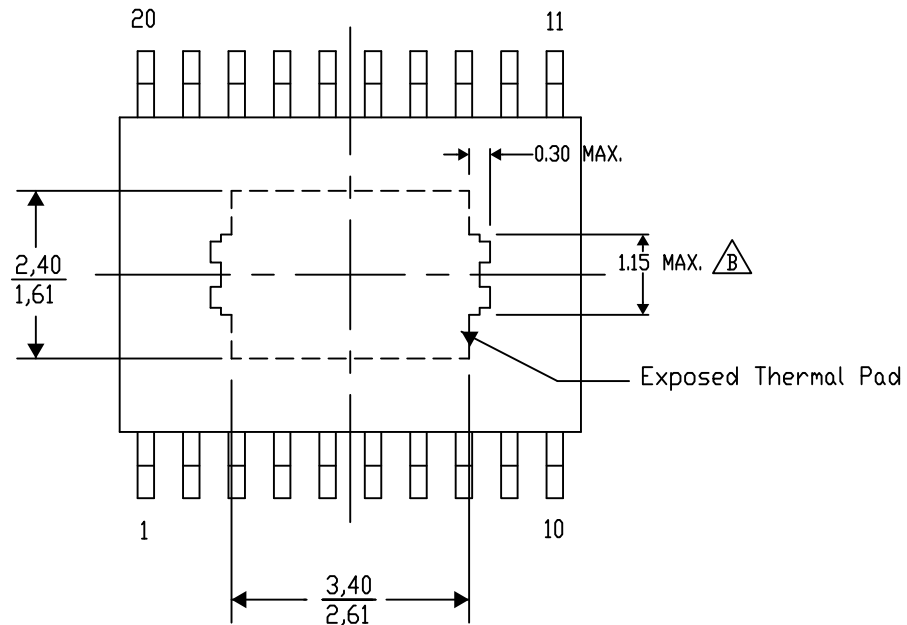

Top View

Exposed Thermal Pad Dimensions

4206332-15/AO 01/16

NOTE: A. All linear dimensions are in millimeters

 Exposed tie strap features may not be present.

PowerPAD is a trademark of Texas Instruments

PWP (R-PDSO-G20)

PowerPAD™ PLASTIC SMALL OUTLINE

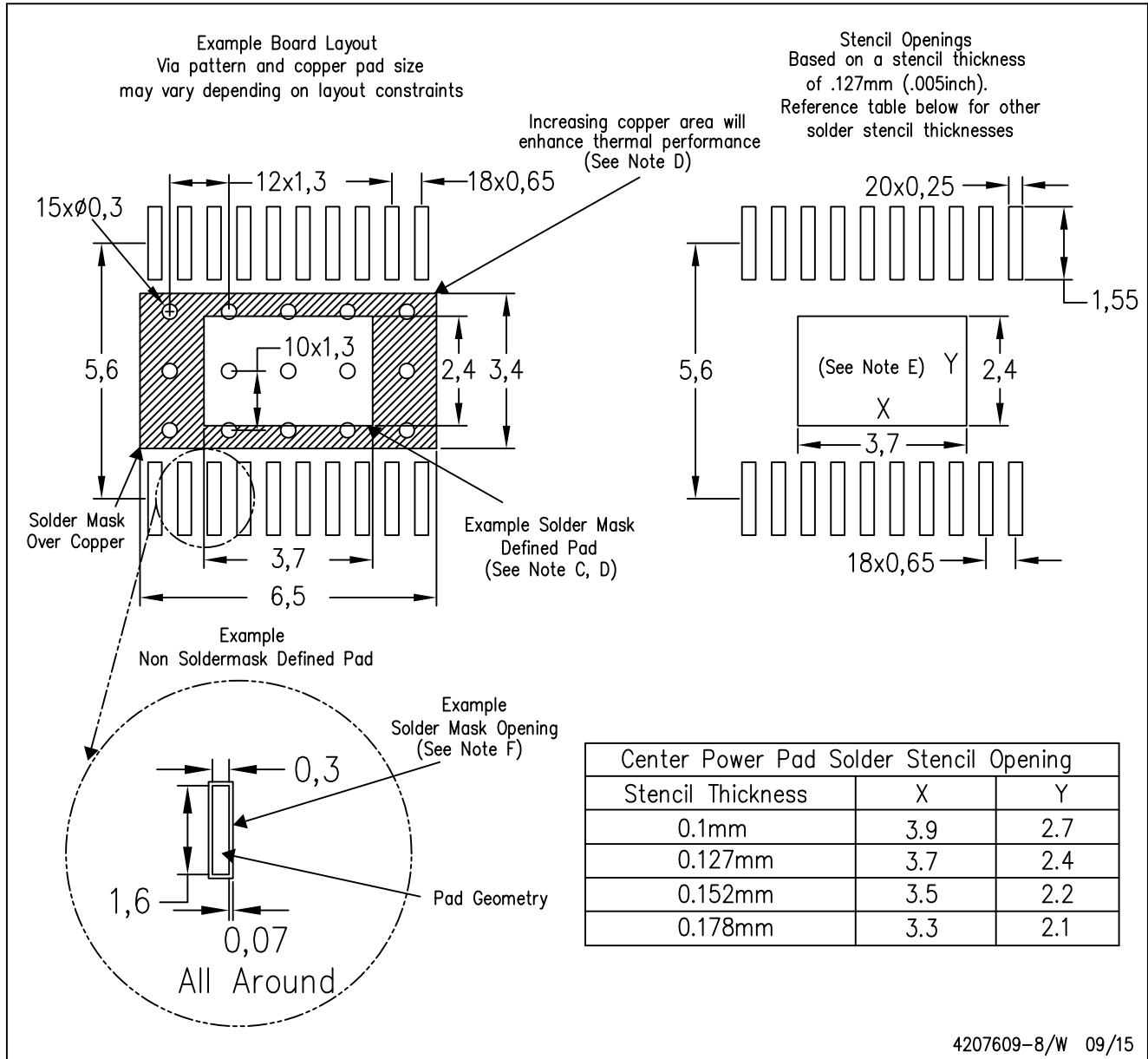

- NOTES:
- A. All linear dimensions are in millimeters.
  - B. This drawing is subject to change without notice.
  - C. Customers should place a note on the circuit board fabrication drawing not to alter the center solder mask defined pad.
  - D. This package is designed to be soldered to a thermal pad on the board. Refer to Technical Brief, PowerPad Thermally Enhanced Package, Texas Instruments Literature No. SLMA002, SLMA004, and also the Product Data Sheets for specific thermal information, via requirements, and recommended board layout. These documents are available at [www.ti.com](http://www.ti.com) <<http://www.ti.com>>. Publication IPC-7351 is recommended for alternate designs.
  - E. Laser cutting apertures with trapezoidal walls and also rounding corners will offer better paste release. Customers should contact their board assembly site for stencil design recommendations. Example stencil design based on a 50% volumetric metal load solder paste. Refer to IPC-7525 for other stencil recommendations.
  - F. Customers should contact their board fabrication site for solder mask tolerances between and around signal pads.

**PACKAGING INFORMATION**

Orderable Device	Status (1)	Package Type	Package Drawing	Pins	Package Qty	Eco Plan (2)	Lead/Ball Finish (6)	MSL Peak Temp (3)	Op Temp (°C)	Device Marking (4/5)	Samples
TPS61193PWPR	ACTIVE	HTSSOP	PWP	20	2000	Green (RoHS & no Sb/Br)	NIPDAU	Level-2-260C-1 YEAR	-40 to 85	TPS61193	<a href="#">Samples</a>

(1) The marketing status values are defined as follows:

**ACTIVE:** Product device recommended for new designs.

**LIFEBUY:** TI has announced that the device will be discontinued, and a lifetime-buy period is in effect.

**NRND:** Not recommended for new designs. Device is in production to support existing customers, but TI does not recommend using this part in a new design.

**PREVIEW:** Device has been announced but is not in production. Samples may or may not be available.

**OBSOLETE:** TI has discontinued the production of the device.

(2) **RoHS:** TI defines "RoHS" to mean semiconductor products that are compliant with the current EU RoHS requirements for all 10 RoHS substances, including the requirement that RoHS substance do not exceed 0.1% by weight in homogeneous materials. Where designed to be soldered at high temperatures, "RoHS" products are suitable for use in specified lead-free processes. TI may reference these types of products as "Pb-Free".

**RoHS Exempt:** TI defines "RoHS Exempt" to mean products that contain lead but are compliant with EU RoHS pursuant to a specific EU RoHS exemption.

**Green:** TI defines "Green" to mean the content of Chlorine (Cl) and Bromine (Br) based flame retardants meet JS709B low halogen requirements of <=1000ppm threshold. Antimony trioxide based flame retardants must also meet the <=1000ppm threshold requirement.

(3) MSL, Peak Temp. - The Moisture Sensitivity Level rating according to the JEDEC industry standard classifications, and peak solder temperature.

(4) There may be additional marking, which relates to the logo, the lot trace code information, or the environmental category on the device.

(5) Multiple Device Markings will be inside parentheses. Only one Device Marking contained in parentheses and separated by a "~" will appear on a device. If a line is indented then it is a continuation of the previous line and the two combined represent the entire Device Marking for that device.

(6) Lead/Ball Finish - Orderable Devices may have multiple material finish options. Finish options are separated by a vertical ruled line. Lead/Ball Finish values may wrap to two lines if the finish value exceeds the maximum column width.

**Important Information and Disclaimer:**The information provided on this page represents TI's knowledge and belief as of the date that it is provided. TI bases its knowledge and belief on information provided by third parties, and makes no representation or warranty as to the accuracy of such information. Efforts are underway to better integrate information from third parties. TI has taken and continues to take reasonable steps to provide representative and accurate information but may not have conducted destructive testing or chemical analysis on incoming materials and chemicals. TI and TI suppliers consider certain information to be proprietary, and thus CAS numbers and other limited information may not be available for release.

In no event shall TI's liability arising out of such information exceed the total purchase price of the TI part(s) at issue in this document sold by TI to Customer on an annual basis.

**OTHER QUALIFIED VERSIONS OF TPS61193 :**

- Automotive: [TPS61193-Q1](#)

NOTE: Qualified Version Definitions:

- Automotive - Q100 devices qualified for high-reliability automotive applications targeting zero defects

**TAPE AND REEL INFORMATION**

**QUADRANT ASSIGNMENTS FOR PIN 1 ORIENTATION IN TAPE**

\*All dimensions are nominal

Device	Package Type	Package Drawing	Pins	SPQ	Reel Diameter (mm)	Reel Width W1 (mm)	A0 (mm)	B0 (mm)	K0 (mm)	P1 (mm)	W (mm)	Pin1 Quadrant
TPS61193PWPR	HTSSOP	PWP	20	2000	330.0	16.4	6.95	7.1	1.6	8.0	16.0	Q1

**TAPE AND REEL BOX DIMENSIONS**



\*All dimensions are nominal

Device	Package Type	Package Drawing	Pins	SPQ	Length (mm)	Width (mm)	Height (mm)
TPS61193PWPR	HTSSOP	PWP	20	2000	350.0	350.0	43.0

# THERMAL PAD MECHANICAL DATA

## PWP (R-PDSO-G20) PowerPAD™ SMALL PLASTIC OUTLINE

### THERMAL INFORMATION

This PowerPAD™ package incorporates an exposed thermal pad that is designed to be attached to a printed circuit board (PCB). The thermal pad must be soldered directly to the PCB. After soldering, the PCB can be used as a heatsink. In addition, through the use of thermal vias, the thermal pad can be attached directly to the appropriate copper plane shown in the electrical schematic for the device, or alternatively, can be attached to a special heatsink structure designed into the PCB. This design optimizes the heat transfer from the integrated circuit (IC).

For additional information on the PowerPAD package and how to take advantage of its heat dissipating abilities, refer to Technical Brief, PowerPAD Thermally Enhanced Package, Texas Instruments Literature No. SLMA002 and Application Brief, PowerPAD Made Easy, Texas Instruments Literature No. SLMA004. Both documents are available at [www.ti.com](http://www.ti.com).

The exposed thermal pad dimensions for this package are shown in the following illustration.

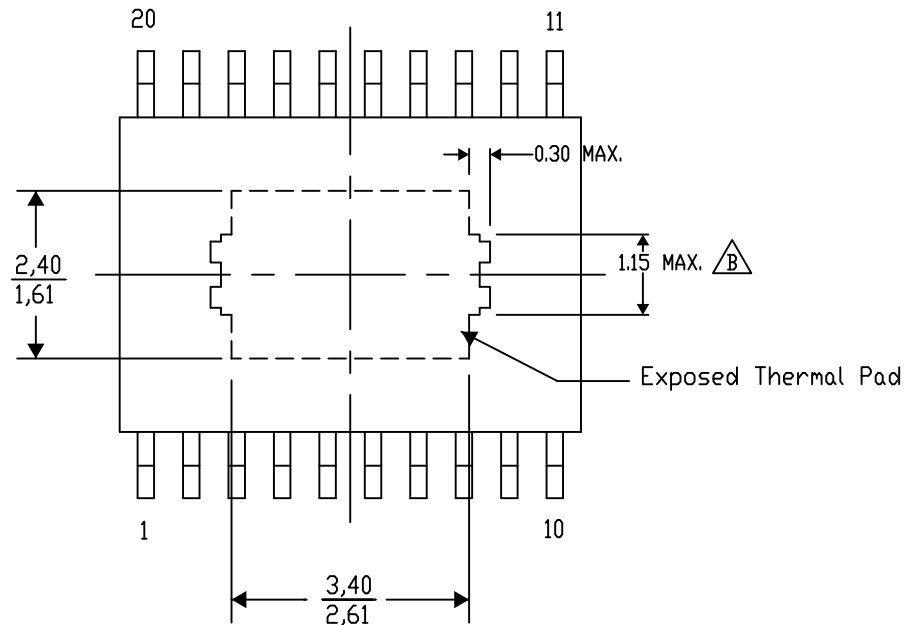

Top View

Exposed Thermal Pad Dimensions

4206332-15/AO 01/16

NOTE: A. All linear dimensions are in millimeters

 Exposed tie strap features may not be present.

PowerPAD is a trademark of Texas Instruments

PWP (R-PDSO-G20)

PowerPAD™ PLASTIC SMALL OUTLINE

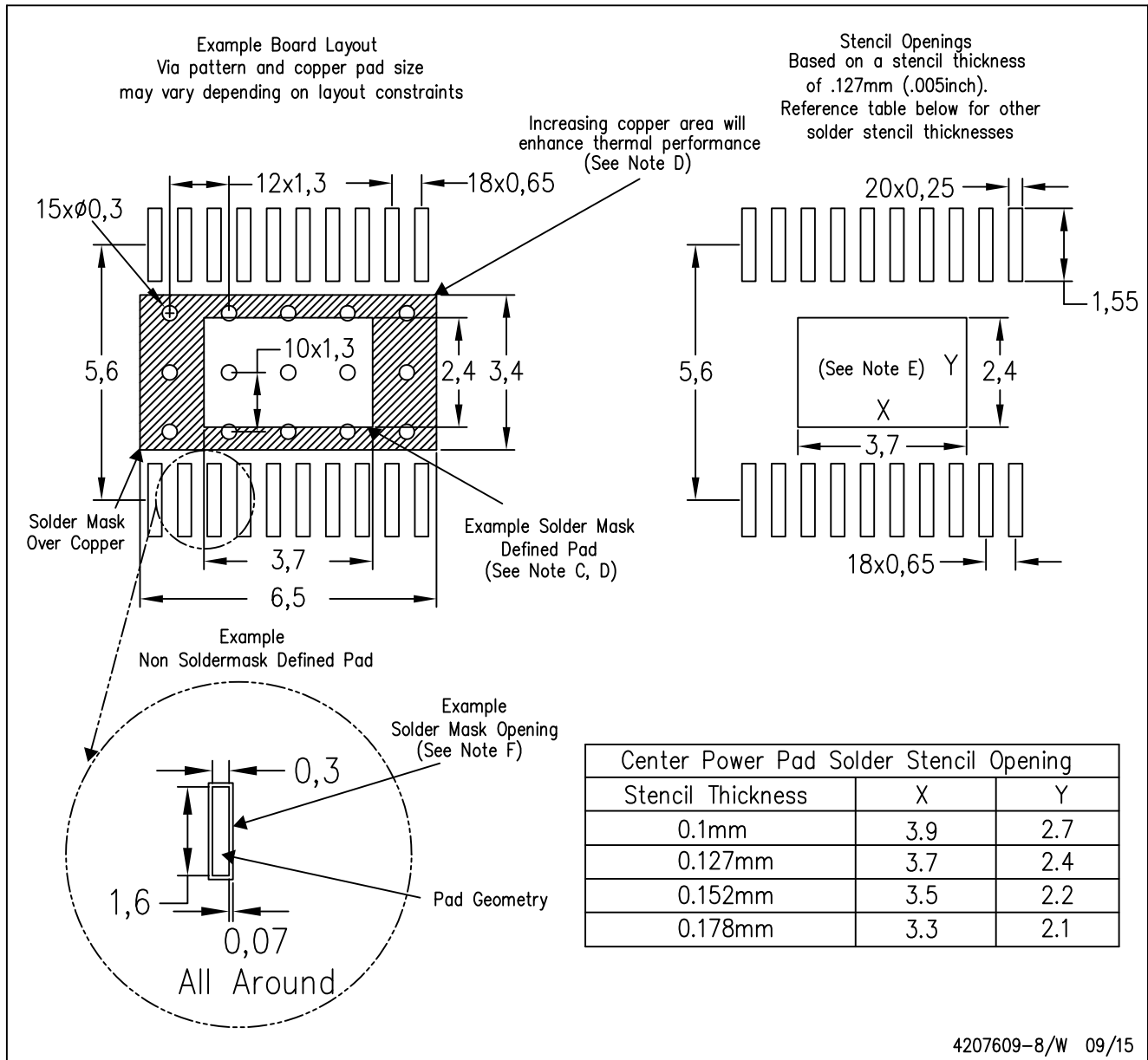

- NOTES:
- All linear dimensions are in millimeters.
  - This drawing is subject to change without notice.
  - Customers should place a note on the circuit board fabrication drawing not to alter the center solder mask defined pad.
  - This package is designed to be soldered to a thermal pad on the board. Refer to Technical Brief, PowerPad Thermally Enhanced Package, Texas Instruments Literature No. SLMA002, SLMA004, and also the Product Data Sheets for specific thermal information, via requirements, and recommended board layout. These documents are available at [www.ti.com](http://www.ti.com) <<http://www.ti.com>>. Publication IPC-7351 is recommended for alternate designs.
  - Laser cutting apertures with trapezoidal walls and also rounding corners will offer better paste release. Customers should contact their board assembly site for stencil design recommendations. Example stencil design based on a 50% volumetric metal load solder paste. Refer to IPC-7525 for other stencil recommendations.
  - Customers should contact their board fabrication site for solder mask tolerances between and around signal pads.

## IMPORTANT NOTICE AND DISCLAIMER

TI PROVIDES TECHNICAL AND RELIABILITY DATA (INCLUDING DATASHEETS), DESIGN RESOURCES (INCLUDING REFERENCE DESIGNS), APPLICATION OR OTHER DESIGN ADVICE, WEB TOOLS, SAFETY INFORMATION, AND OTHER RESOURCES "AS IS" AND WITH ALL FAULTS, AND DISCLAIMS ALL WARRANTIES, EXPRESS AND IMPLIED, INCLUDING WITHOUT LIMITATION ANY IMPLIED WARRANTIES OF MERCHANTABILITY, FITNESS FOR A PARTICULAR PURPOSE OR NON-INFRINGEMENT OF THIRD PARTY INTELLECTUAL PROPERTY RIGHTS.

These resources are intended for skilled developers designing with TI products. You are solely responsible for (1) selecting the appropriate TI products for your application, (2) designing, validating and testing your application, and (3) ensuring your application meets applicable standards, and any other safety, security, or other requirements. These resources are subject to change without notice. TI grants you permission to use these resources only for development of an application that uses the TI products described in the resource. Other reproduction and display of these resources is prohibited. No license is granted to any other TI intellectual property right or to any third party intellectual property right. TI disclaims responsibility for, and you will fully indemnify TI and its representatives against, any claims, damages, costs, losses, and liabilities arising out of your use of these resources.

TI's products are provided subject to TI's Terms of Sale ([www.ti.com/legal/termsofsale.html](http://www.ti.com/legal/termsofsale.html)) or other applicable terms available either on [ti.com](http://ti.com) or provided in conjunction with such TI products. TI's provision of these resources does not expand or otherwise alter TI's applicable warranties or warranty disclaimers for TI products.

Mailing Address: Texas Instruments, Post Office Box 655303, Dallas, Texas 75265  
Copyright © 2020, Texas Instruments Incorporated