

# UCC21222 4-A, 6-A, 3.0-kV<sub>RMS</sub> Isolated Dual-Channel Gate Driver with Dead Time

## 1 Features

- Resistor-Programmable Dead Time
- Universal: Dual Low-Side, Dual High-Side or Half-Bridge Driver
- 4-A Peak Source, 6-A Peak Sink Output
- 3-V to 5.5-V Input VCCI Range
- Up to 18-V VDD Output Drive Supply
  - 8-V VDD UVLO
- Switching Parameters:
  - 28-ns Typical Propagation Delay
  - 10-ns Minimum Pulse Width
  - 5-ns Maximum Delay Matching
  - 5.5-ns Maximum Pulse-Width Distortion
- TTL and CMOS Compatible Inputs
- Integrated Deglitch Filter
- I/Os withstand –2-V for 200 ns
- Common-Mode Transient Immunity (CMTI) Greater than 100-V/ns
- Isolation Barrier Life >40 Years
- Surge Immunity up to 7800-V<sub>PK</sub>
- Narrow Body SOIC-16 (D) Package
- Safety-Related Certifications (Planned):
  - 4242-V<sub>PK</sub> Isolation per DIN V VDE V 0884-11:2017-01 and DIN EN 61010-1
  - 3000-V<sub>RMS</sub> Isolation for 1 Minute per UL 1577
  - CSA Certification per IEC 60950-1, IEC 62368-1 and IEC 61010-1 End Equipment Standards
  - CQC Certification per GB4943.1-2011
- Create a Custom Design Using the UCC21222 With the [WEBENCH® Power Designer](#)

## 2 Applications

- Isolated converters in AC-to-DC and DC-to-DC Power Supplies
- Server, Telecom, IT and Industrial Infrastructures
- Motor Drives and Solar Inverters
- HEV and EV Battery Chargers
- Industrial Transportation
- Uninterruptible Power Supply (UPS)

## 3 Description

The UCC21222 device is an isolated dual channel gate driver with programmable dead time. It is designed with 4-A peak-source and 6-A peak-sink current to drive power MOSFET, IGBT, and GaN transistors.

The UCC21222 device can be configured as two low-side drivers, two high-side drivers, or a half-bridge driver. 5ns delay matching performance allows two outputs to be paralleled, doubling the drive strength for heavy load conditions without risk of internal shoot-through.

The input side is isolated from the two output drivers by a 3.0-kV<sub>RMS</sub> isolation barrier, with a minimum of 100-V/ns common-mode transient immunity (CMTI).

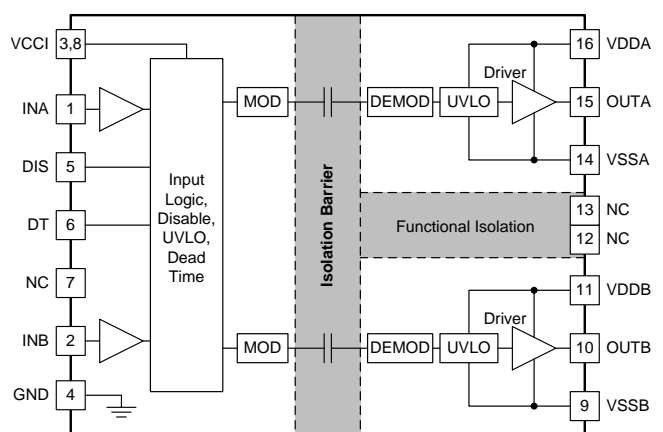
Resistor programmable dead time gives the capability to adjust dead time for system constraints to improve efficiency and prevent output overlap. Other protection features include: Disable feature to shut down both outputs simultaneously when DIS is set high, integrated deglitch filter that rejects input transients shorter than 5-ns, and negative voltage handling for up to -2-V spikes for 200-ns on input and output pins. All supplies have UVLO protection.

### Device Information<sup>(1)</sup>

PART NUMBER	PACKAGE	BODY SIZE (NOM)
UCC21222	SOIC (16)	9.9 mm × 3.91 mm

(1) For all available packages, see the orderable addendum at the end of the data sheet.

### Functional Block Diagram



Copyright © 2018, Texas Instruments Incorporated



## Table of Contents

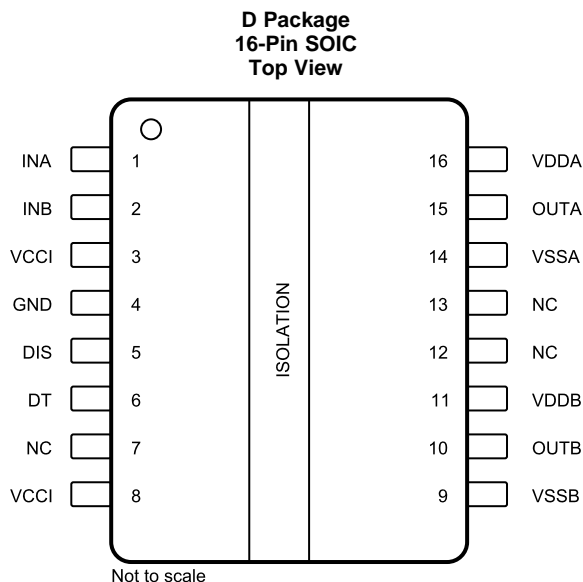
<b>1 Features</b> .....	<b>1</b>	7.6 Power-up UVLO Delay to OUTPUT.....	<b>17</b>
<b>2 Applications</b> .....	<b>1</b>	7.7 CMTI Testing.....	<b>18</b>
<b>3 Description</b> .....	<b>1</b>	<b>8 Detailed Description</b> .....	<b>19</b>
<b>4 Revision History</b> .....	<b>2</b>	8.1 Overview .....	<b>19</b>
<b>5 Pin Configuration and Functions</b> .....	<b>3</b>	8.2 Functional Block Diagram .....	<b>19</b>
<b>6 Specifications</b> .....	<b>4</b>	8.3 Feature Description.....	<b>20</b>
6.1 Absolute Maximum Ratings .....	<b>4</b>	8.4 Device Functional Modes.....	<b>23</b>
6.2 ESD Ratings.....	<b>4</b>	<b>9 Application and Implementation</b> .....	<b>25</b>
6.3 Recommended Operating Conditions.....	<b>4</b>	9.1 Application Information.....	<b>25</b>
6.4 Thermal Information .....	<b>5</b>	9.2 Typical Application .....	<b>25</b>
6.5 Power Ratings.....	<b>5</b>	<b>10 Power Supply Recommendations</b> .....	<b>36</b>
6.6 Insulation Specifications.....	<b>6</b>	<b>11 Layout</b> .....	<b>37</b>
6.7 Safety-Related Certifications.....	<b>7</b>	11.1 Layout Guidelines .....	<b>37</b>
6.8 Safety-Limiting Values .....	<b>7</b>	11.2 Layout Example .....	<b>38</b>
6.9 Electrical Characteristics.....	<b>8</b>	<b>12 Device and Documentation Support</b> .....	<b>40</b>
6.10 Switching Characteristics .....	<b>9</b>	12.1 Device Support.....	<b>40</b>
6.11 Thermal Derating Curves .....	<b>10</b>	12.2 Documentation Support .....	<b>40</b>
6.12 Typical Characteristics .....	<b>11</b>	12.3 Related Links .....	<b>40</b>
<b>7 Parameter Measurement Information</b> .....	<b>15</b>	12.4 Receiving Notification of Documentation Updates	<b>40</b>
7.1 Minimum Pulses.....	<b>15</b>	12.5 Community Resources.....	<b>40</b>
7.2 Propagation Delay and Pulse Width Distortion .....	<b>15</b>	12.6 Trademarks .....	<b>40</b>
7.3 Rising and Falling Time .....	<b>15</b>	12.7 Electrostatic Discharge Caution.....	<b>41</b>
7.4 Input and Disable Response Time.....	<b>16</b>	12.8 Glossary .....	<b>41</b>
7.5 Programmable Dead Time.....	<b>16</b>	<b>13 Mechanical, Packaging, and Orderable Information</b> .....	<b>41</b>

## 4 Revision History

NOTE: Page numbers for previous revisions may differ from page numbers in the current version.

DATE	REVISION	NOTES
April 2018	*	Initial release.

## 5 Pin Configuration and Functions



### Pin Functions

PIN		I/O <sup>(1)</sup>	Description
NAME	NO.		
DIS	5	I	Disables both driver outputs if asserted high, enables if set low or left open. This pin is pulled low internally if left open. It is recommended to tie this pin to ground if not used to achieve better noise immunity. Bypass using a $\approx 1$ -nF low ESR/ESL capacitor close to DIS pin when connecting to a $\mu$ C with distance.
DT	6	I	Programmable dead time function. Tying DT to VCCI or leaving DT open allows the outputs to overlap. Placing a resistor ( $R_{DT}$ ) between DT and GND adjusts dead time according to the equation: $DT$ (in ns) = $10 \times R_{DT}$ (in k $\Omega$ ). TI recommends bypassing this pin with a ceramic capacitor, 2.2 nF or greater, to achieve better noise immunity. Place this capacitor and $R_{DT}$ close to the DT pin.
GND	4	P	Primary-side ground reference. All signals in the primary side are referenced to this ground.
INA	1	I	Input signal for A channel. INA input has a TTL/CMOS compatible input threshold. This pin is pulled low internally if left open. It is recommended to tie this pin to ground if not used to achieve better noise immunity.
INB	2	I	Input signal for B channel. INB input has a TTL/CMOS compatible input threshold. This pin is pulled low internally if left open. It is recommended to tie this pin to ground if not used to achieve better noise immunity.
NC	7	-	No internal connection.
	12		
	13		
OUTA	15	O	Output of driver A. Connect to the gate of the A channel FET or IGBT.
OUTB	10	O	Output of driver B. Connect to the gate of the B channel FET or IGBT.
VCCI	3	P	Primary-side supply voltage. Locally decoupled to GND using a low ESR/ESL capacitor located as close to the device as possible.
VCCI	8	P	This pin is internally shorted to pin 3.
VDDA	16	P	Secondary-side power for driver A. Locally decoupled to VSSA using a low ESR/ESL capacitor located as close to the device as possible.
Vddb	11	P	Secondary-side power for driver B. Locally decoupled to VSSB using a low ESR/ESL capacitor located as close to the device as possible.
VSSA	14	P	Ground for secondary-side driver A. Ground reference for secondary side A channel.
VSSB	9	P	Ground for secondary-side driver B. Ground reference for secondary side B channel.

(1) P = power, I = input, O = output

## 6 Specifications

### 6.1 Absolute Maximum Ratings

 over operating free-air temperature range (unless otherwise noted)<sup>(1)</sup>

		MIN	MAX	UNIT
Input bias pin supply voltage	VCCI to GND	-0.5	6	V
Driver bias supply	VDDA-VSSA, VDDB-VSSB	-0.5	20	V
Output signal voltage	OUTA to VSSA, OUTB to VSSB	-0.5	V <sub>VDDA</sub> +0.5, V <sub>VDDB</sub> +0.5	V
	OUTA to VSSA, OUTB to VSSB, Transient for 200 ns <sup>(2)</sup>	-2	V <sub>VDDA</sub> +0.5, V <sub>VDDB</sub> +0.5	V
Input signal voltage	INA, INB, DIS to GND	-0.5	V <sub>VCCI</sub> +0.5	V
	INA, INB Transient to GND for 200ns <sup>(2)</sup>	-2	V <sub>VCCI</sub> +0.5	V
Junction temperature, T <sub>J</sub> <sup>(3)</sup>		-40	150	°C
Storage temperature, T <sub>stg</sub>		-65	150	°C

- (1) Stresses beyond those listed under absolute maximum ratings may cause permanent damage to the device. These are stress ratings only and functional operation of the device at these or any other conditions beyond those indicated under recommended operating conditions is not implied. Exposure to absolute-maximum-rated conditions for extended periods may affect device reliability.
- (2) Values are verified by characterization and are not production tested.
- (3) To maintain the recommended operating conditions for T<sub>J</sub>, see the [Thermal Information](#).

### 6.2 ESD Ratings

		VALUE	UNIT
V <sub>(ESD)</sub> Electrostatic discharge	Human-body model (HBM), per ANSI/ESDA/JEDEC JS-001 <sup>(1)</sup>	±4000	V
	Charged-device model (CDM), per JEDEC specification JESD22-C101 <sup>(2)</sup>	±1500	

- (1) JEDEC document JEP155 states that 500-V HBM allows safe manufacturing with a standard ESD control process.
- (2) JEDEC document JEP157 states that 250-V CDM allows safe manufacturing with a standard ESD control process.

### 6.3 Recommended Operating Conditions

Over operating free-air temperature range (unless otherwise noted)

		MIN	MAX	UNIT
VCCI	VCCI Input supply voltage	3	5.5	V
VDDA, VDDB	Driver output bias supply	9.2	18	V
T <sub>J</sub>	Junction Temperature	-40	130	°C
T <sub>A</sub>	Ambient Temperature	-40	125	°C

## 6.4 Thermal Information

THERMAL METRIC <sup>(1)</sup>		UCC21222	UNIT
		D (SOIC)	
		16 PINS	
$R_{\theta JA}$	Junction-to-ambient thermal resistance	68.5	°C/W
$R_{\theta JC(top)}$	Junction-to-case (top) thermal resistance	30.5	°C/W
$R_{\theta JB}$	Junction-to-board thermal resistance	22.8	°C/W
$\Psi_{JT}$	Junction-to-top characterization parameter	17.1	°C/W
$\Psi_{JB}$	Junction-to-board characterization parameter	22.5	°C/W

(1) For more information about traditional and new thermal metrics, see the *Semiconductor and IC Package Thermal Metrics* application report, [SPRA953](#).

## 6.5 Power Ratings

		VALUE	UNIT	
$P_D$	Power dissipation	VCCI = 5.5 V, VDDA/B = 12 V, INA/B = 3.3 V, 5.4 MHz 50% duty cycle square wave 1.0-nF load	1825	mW
$P_{DI}$	Power dissipation by transmitter side		15	mW
$P_{DA}, P_{DB}$	Power dissipation by each driver side		905	mW

## 6.6 Insulation Specifications

PARAMETER		TEST CONDITIONS	VALUE	UNIT
CLR	External clearance <sup>(1)</sup>	Shortest pin-to-pin distance through air	> 4	mm
CPG	External creepage <sup>(1)</sup>	Shortest pin-to-pin distance across the package surface	> 4	mm
DTI	Distance through the insulation	Minimum internal gap (internal clearance)	>17	µm
CTI	Comparative tracking index	DIN EN 60112 (VDE 0303-11); IEC 60112	> 600	V
	Material group		I	
	Overvoltage category per IEC 60664-1	Rated mains voltage ≤ 150 V <sub>RMS</sub>	I-IV	
		Rated mains voltage ≤ 300 V <sub>RMS</sub>	I-III	
		Rated mains voltage ≤ 600 V <sub>RMS</sub>	I-II	
<b>DIN V VDE V 0884-11:2017-01<sup>(2)</sup></b>				
V <sub>IORM</sub>	Maximum repetitive peak isolation voltage	AC voltage (bipolar)	990	V <sub>PK</sub>
V <sub>IOWM</sub>	Maximum working isolation voltage	AC voltage (sine wave); time dependent dielectric breakdown (TDDB) test;	700	V <sub>RMS</sub>
		DC Voltage	990	V <sub>DC</sub>
V <sub>IOTM</sub>	Maximum transient isolation voltage	V <sub>TEST</sub> = V <sub>IOTM</sub> , t = 60 s (qualification); V <sub>TEST</sub> = 1.2 × V <sub>IOTM</sub> , t = 1 s (100% production)	4242	V <sub>PK</sub>
V <sub>IOSM</sub>	Maximum surge isolation voltage <sup>(3)</sup>	Test method per IEC 62368-1, 1.2/50 µs waveform, V <sub>TEST</sub> = 1.3 × V <sub>IOSM</sub> = 7800 V <sub>PK</sub> (qualification)	6000	V <sub>PK</sub>
q <sub>pd</sub>	Apparent charge <sup>(4)</sup>	Method a, After Input/Output safety test subgroup 2/3, V <sub>ini</sub> = V <sub>IOTM</sub> , t <sub>ini</sub> = 60s; V <sub>pd(m)</sub> = 1.2 × V <sub>IORM</sub> , t <sub>m</sub> = 10s	<5	pC
		Method a, After environmental tests subgroup 1, V <sub>ini</sub> = V <sub>IOTM</sub> , t <sub>ini</sub> = 60s; V <sub>pd(m)</sub> = 1.2 × V <sub>IORM</sub> , t <sub>m</sub> = 10s	<5	
		Method b1; At routine test (100% production) and preconditioning (type test) V <sub>ini</sub> = 1.2 × V <sub>IOTM</sub> ; t <sub>ini</sub> = 1 s; V <sub>pd(m)</sub> = 1.5 × V <sub>IORM</sub> , t <sub>m</sub> = 1s	<5	
C <sub>IO</sub>	Barrier capacitance, input to output <sup>(5)</sup>	V <sub>IO</sub> = 0.4 sin (2πft), f = 1 MHz	0.5	pF
R <sub>IO</sub>	Isolation resistance, input to output	V <sub>IO</sub> = 500 V at T <sub>A</sub> = 25°C	> 10 <sup>12</sup>	Ω
		V <sub>IO</sub> = 500 V at 100°C ≤ T <sub>A</sub> ≤ 125°C	> 10 <sup>11</sup>	
		V <sub>IO</sub> = 500 V at T <sub>S</sub> = 150°C	> 10 <sup>9</sup>	
	Pollution degree		2	
	Climatic category		40/125/21	
<b>UL 1577</b>				
V <sub>ISO</sub>	Withstand isolation voltage	V <sub>TEST</sub> = V <sub>ISO</sub> = 3000 V <sub>RMS</sub> , t = 60 sec. (qualification), V <sub>TEST</sub> = 1.2 × V <sub>ISO</sub> = 3600V <sub>RMS</sub> , t = 1 sec (100% production)	3000	V <sub>RMS</sub>

- (1) Creepage and clearance requirements should be applied according to the specific equipment isolation standards of an application. Care should be taken to maintain the creepage and clearance distance of a board design to ensure that the mounting pads of the isolator on the printed-circuit board do not reduce this distance. Creepage and clearance on a printed-circuit board become equal in certain cases. Techniques such as inserting grooves, ribs, or both on a printed circuit board are used to help increase these specifications.
- (2) This coupler is suitable for basic electrical insulation only within the maximum operating ratings. Compliance with the safety ratings shall be ensured by means of suitable protective circuits.
- (3) Testing is carried out in air or oil to determine the intrinsic surge immunity of the isolation barrier.
- (4) Apparent charge is electrical discharge caused by a partial discharge (pd).
- (5) All pins on each side of the barrier tied together creating a two-pin device.

## 6.7 Safety-Related Certifications

VDE	CSA	UL	CQC
Plan to certify according to DIN V VDE V 0884-11:2017-01 and DIN EN 61010-1 (VDE 0411-1):2011-07	Plan to certify according to IEC 60950-1, IEC 62368-1 and IEC 61010-1	Plan to be recognized under UL 1577 Component Recognition Program	Plan to certify according to GB 4943.1-2011

## 6.8 Safety-Limiting Values

Safety limiting intends to minimize potential damage to the isolation barrier upon failure of input or output circuitry.

PARAMETER	TEST CONDITIONS	SIDE	MIN	TYP	MAX	UNIT
$I_S$ Safety output supply current	$\theta_{JA} = 68.5^\circ\text{C}/\text{W}$ , $V_{VDDA/B} = 12\text{ V}$ , $T_J = 150^\circ\text{C}$ , $T_A = 25^\circ\text{C}$ See	DRIVER A, DRIVER B			75	mA
$P_S$ Safety supply power	$\theta_{JA} = 68.5^\circ\text{C}/\text{W}$ , $V_{VCCI} = 5.5\text{ V}$ , $T_J = 150^\circ\text{C}$ , $T_A = 25^\circ\text{C}$ See	INPUT			15	mW
		DRIVER A			905	
		DRIVER B			905	
		TOTAL			1825	
$T_S$ Safety temperature <sup>(1)</sup>					150	$^\circ\text{C}$

- (1) The maximum safety temperature,  $T_S$ , has the same value as the maximum junction temperature,  $T_J$ , specified for the device. The  $I_S$  and  $P_S$  parameters represent the safety current and safety power respectively. The maximum limits of  $I_S$  and  $P_S$  should not be exceeded. These limits vary with the ambient temperature,  $T_A$ .

The junction-to-air thermal resistance,  $R_{\theta JA}$ , in the [Thermal Information](#) table is that of a device installed on a high-K test board for leaded surface-mount packages. Use these equations to calculate the value for each parameter:

$T_J = T_A + R_{\theta JA} \times P$ , where P is the power dissipated in the device.

$T_{J(\text{max})} = T_S = T_A + R_{\theta JA} \times P_S$ , where  $T_{J(\text{max})}$  is the maximum allowed junction temperature.

$P_S = I_S \times V_I$ , where  $V_I$  is the maximum input voltage.

## 6.9 Electrical Characteristics

$V_{VCCI} = 3.3\text{ V}$  or  $5.0\text{ V}$ ,  $0.1\text{-}\mu\text{F}$  capacitor from  $V_{VCCI}$  to GND and  $1\text{-}\mu\text{F}$  capacitor from  $V_{VDDA/B}$  to  $V_{VSSA/B}$ ,  $V_{VDDA} = V_{VDDB} = 12\text{ V}$ ,  $1\text{-}\mu\text{F}$  capacitor from  $V_{VDDA}$  and  $V_{VDDB}$  to  $V_{VSSA}$  and  $V_{VSSB}$ , DT pin tied to  $V_{VCCI}$ ,  $C_L = 0\text{ pF}$ ,  $T_A = -40^\circ\text{C}$  to  $+125^\circ\text{C}$  unless otherwise noted<sup>(1)(2)</sup>.

PARAMETER	TEST CONDITIONS	MIN	TYP	MAX	UNIT	
<b>SUPPLY CURRENTS</b>						
$I_{VCCI}$	VCCI quiescent current	$V_{INA} = 0\text{ V}$ , $V_{INB} = 0\text{ V}$		1.5	2.0	mA
$I_{VDDA}$ , $I_{VDDB}$	VDDA and VDDB quiescent current	$V_{INA} = 0\text{ V}$ , $V_{INB} = 0\text{ V}$		1.0	1.8	mA
$I_{VCCI}$	VCCI operating current	(f = 500 kHz) current per channel		2.5		mA
$I_{VDDA}$ , $I_{VDDB}$	VDDA and VDDB operating current	(f = 500 kHz) current per channel, $C_{OUT} = 100\text{ pF}$ , $V_{VDDA}$ , $V_{VDDB} = 12\text{ V}$		2.5		mA
<b>VCC SUPPLY VOLTAGE UNDERVOLTAGE THRESHOLDS</b>						
$V_{VCCI\_ON}$	UVLO Rising threshold	2.55	2.7	2.85	V	
$V_{VCCI\_OFF}$	UVLO Falling threshold	2.35	2.5	2.65	V	
$V_{VCCI\_HYS}$	UVLO Threshold hysteresis		0.2		V	
<b>VDD SUPPLY VOLTAGE UNDERVOLTAGE THRESHOLDS</b>						
$V_{VDDA\_ON}$ , $V_{VDDB\_ON}$	UVLO Rising threshold	8	8.5	9	V	
$V_{VDDA\_OFF}$ , $V_{VDDB\_OFF}$	UVLO Falling threshold	7.5	8	8.5	V	
$V_{VDDA\_HYS}$ , $V_{VDDB\_HYS}$	UVLO Threshold hysteresis		0.5		V	
<b>INA, INB AND DISABLE</b>						
$V_{INAH}$ , $V_{INBH}$ , $V_{DISH}$	Input high threshold voltage	1.6	1.8	2	V	
$V_{INAL}$ , $V_{INBL}$ , $V_{DISL}$	Input low threshold voltage	0.8	1	1.25	V	
$V_{INA\_HYS}$ , $V_{INB\_HYS}$ , $V_{DIS\_HYS}$	Input threshold hysteresis		0.8		V	
<b>OUTPUT</b>						
$I_{OA+}$ , $I_{OB+}$	Peak output source current	$C_{VDD} = 10\text{ }\mu\text{F}$ , $C_{LOAD} = 0.18\text{ }\mu\text{F}$ , f = 1 kHz, bench measurement		4		A
$I_{OA-}$ , $I_{OB-}$	Peak output sink current	$C_{VDD} = 10\text{ }\mu\text{F}$ , $C_{LOAD} = 0.18\text{ }\mu\text{F}$ , f = 1 kHz, bench measurement		6		A
$R_{OHA}$ , $R_{OHB}$	Output resistance at high state	$I_{OUT} = -10\text{ mA}$ , $R_{OHA}$ , $R_{OHB}$ do not represent drive pull-up performance. See $t_{RISE}$ in <a href="#">Switching Characteristics</a> and <a href="#">Output Stage</a> for details.		5		$\Omega$
$R_{OLA}$ , $R_{OLB}$	Output resistance at low state	$I_{OUT} = 10\text{ mA}$		0.55		$\Omega$
$V_{OHA}$ , $V_{OHB}$	Output voltage at high state	$V_{VDDA}$ , $V_{VDDB} = 12\text{ V}$ , $I_{OUT} = -10\text{ mA}$		11.95		V
$V_{OLA}$ , $V_{OLB}$	Output voltage at low state	$V_{VDDA}$ , $V_{VDDB} = 12\text{ V}$ , $I_{OUT} = 10\text{ mA}$		5.5		mV
$V_{OAPDA}$ , $V_{OAPDB}$	Driver output ( $V_{OUTA}$ , $V_{OUTB}$ ) active pull down	$V_{VDDA}$ and $V_{VDDB}$ unpowered, $I_{OUTA}$ , $I_{OUTB} = 200\text{ mA}$		1.75	2.1	V

- (1) Current direction in the testing conditions are defined to be positive into the pin and negative out of the specified terminal (unless otherwise noted).
- (2) Parameters with only a typical value are provided for reference only, and do not constitute part of TI's published device specifications for purposes of TI's product warranty.

## Electrical Characteristics (continued)

$V_{VCCI} = 3.3\text{ V}$  or  $5.0\text{ V}$ ,  $0.1\text{-}\mu\text{F}$  capacitor from  $V_{VCCI}$  to GND and  $1\text{-}\mu\text{F}$  capacitor from  $V_{VDDA/B}$  to  $V_{VSSA/B}$ ,  $V_{VDDA} = V_{VDDB} = 12\text{ V}$ ,  $1\text{-}\mu\text{F}$  capacitor from  $V_{VDDA}$  and  $V_{VDDB}$  to  $V_{VSSA}$  and  $V_{VSSB}$ , DT pin tied to  $V_{VCCI}$ ,  $C_L = 0\text{ pF}$ ,  $T_A = -40^\circ\text{C}$  to  $+125^\circ\text{C}$  unless otherwise noted<sup>(1)(2)</sup>.

PARAMETER	TEST CONDITIONS	MIN	TYP	MAX	UNIT
<b>DEAD TIME AND OVERLAP PROGRAMMING</b>					
Dead time, DT	DT pin open or pull DT pin to $V_{VCCI}$	Overlap determined by INA, INB			-
	$R_{DT} = 10\text{ k}\Omega$	80	100	120	ns
	$R_{DT} = 20\text{ k}\Omega$	160	200	240	
$R_{DT} = 50\text{ k}\Omega$	400	500	600		
Dead time matching, $ DT_{AB} - DT_{BA} $	$R_{DT} = 10\text{ k}\Omega$	-	0	10	ns
	$R_{DT} = 20\text{ k}\Omega$	-	0	20	
	$R_{DT} = 50\text{ k}\Omega$	-	0	65	

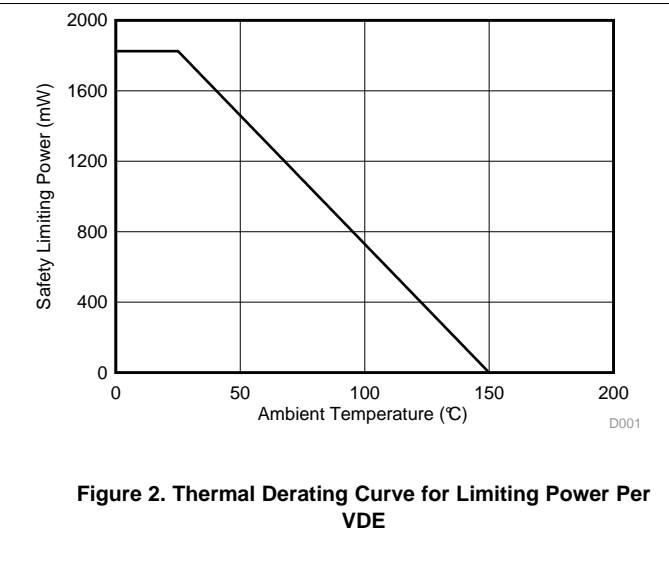
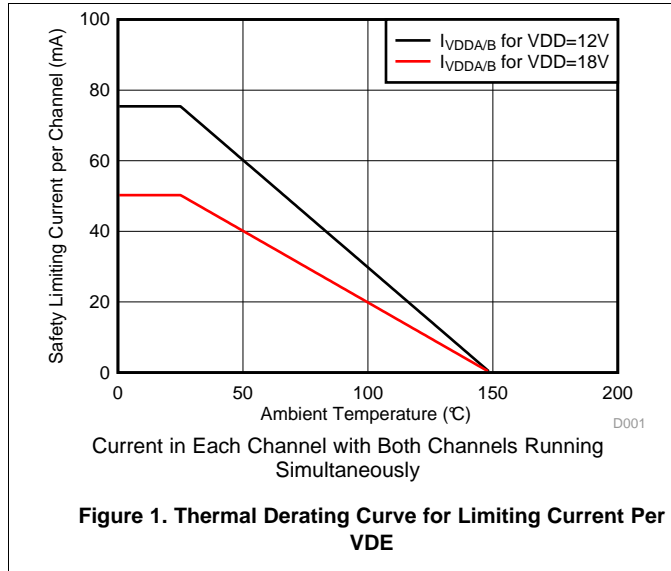
## 6.10 Switching Characteristics

$V_{VCCI} = 3.3\text{ V}$  or  $5.5\text{ V}$ ,  $0.1\text{-}\mu\text{F}$  capacitor from  $V_{VCCI}$  to GND,  $V_{VDDA} = V_{VDDB} = 12\text{ V}$ ,  $1\text{-}\mu\text{F}$  capacitor from  $V_{VDDA}$  and  $V_{VDDB}$  to  $V_{VSSA}$  and  $V_{VSSB}$ , load capacitance  $C_{OUT} = 0\text{ pF}$ ,  $T_A = -40^\circ\text{C}$  to  $+125^\circ\text{C}$  unless otherwise noted<sup>(1)</sup>.

PARAMETER	TEST CONDITIONS	MIN	TYP	MAX	UNIT
$t_{RISE}$	Output rise time, see <a href="#">Figure 28</a>	$C_{VDD} = 10\text{ }\mu\text{F}$ , $C_{OUT} = 1.8\text{ nF}$ , $V_{VDDA}$ , $V_{VDDB} = 12\text{ V}$ , $f = 1\text{ kHz}$			ns
$t_{FALL}$	Output fall time, see <a href="#">Figure 28</a>	$C_{VDD} = 10\text{ }\mu\text{F}$ , $C_{OUT} = 1.8\text{ nF}$ , $V_{VDDA}$ , $V_{VDDB} = 12\text{ V}$ , $f = 1\text{ kHz}$			ns
$t_{PWmin}$	Minimum input pulse width that passes to output, see <a href="#">Figure 25</a> and <a href="#">Figure 26</a>	Output does not change the state if input signal less than $t_{PWmin}$			ns
$t_{PDHL}$	Propagation delay at falling edge, see <a href="#">Figure 27</a>	INx high threshold, $V_{INH}$ , to 10% of the output			ns
$t_{PDLH}$	Propagation delay at rising edge, see <a href="#">Figure 27</a>	INx low threshold, $V_{INL}$ , to 90% of the output			ns
$t_{PWD}$	Pulse width distortion in each channel, see <a href="#">Figure 27</a>	$ t_{PDLHA} - t_{PDHLA} $ , $ t_{PDLHB} - t_{PDHLB} $			ns
$t_{DM}$	Propagation delays matching, $ t_{PDLHA} - t_{PDLHB} $ , $ t_{PDHLA} - t_{PDHLB} $ , see <a href="#">Figure 27</a>	$f = 250\text{ kHz}$			ns
$t_{VCCI+ to OUT}$	$V_{VCCI}$ Power-up Delay Time: UVLO Rise to OUTA, OUTB, See <a href="#">Figure 31</a>	INA or INB tied to $V_{VCCI}$			$\mu\text{s}$
$t_{VDD+ to OUT}$	$V_{VDDA}$ , $V_{VDDB}$ Power-up Delay Time: UVLO Rise to OUTA, OUTB See <a href="#">Figure 32</a>	INA or INB tied to $V_{VCCI}$			
$ CM_H $	High-level common-mode transient immunity (See <a href="#">CMTI Testing</a> )	Slew rate of GND vs. $V_{VSSA/B}$ , INA and INB both are tied to GND or $V_{VCCI}$ ; $V_{CM} = 1000\text{ V}$ ;			V/ns
$ CM_L $	Low-level common-mode transient immunity (See <a href="#">CMTI Testing</a> )	Slew rate of GND vs. $V_{VSSA/B}$ , INA and INB both are tied to GND or $V_{VCCI}$ ; $V_{CM} = 1000\text{ V}$ ;			

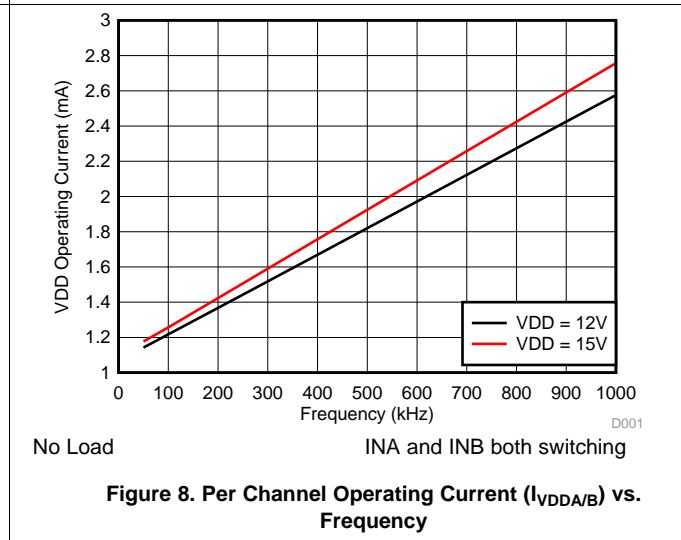
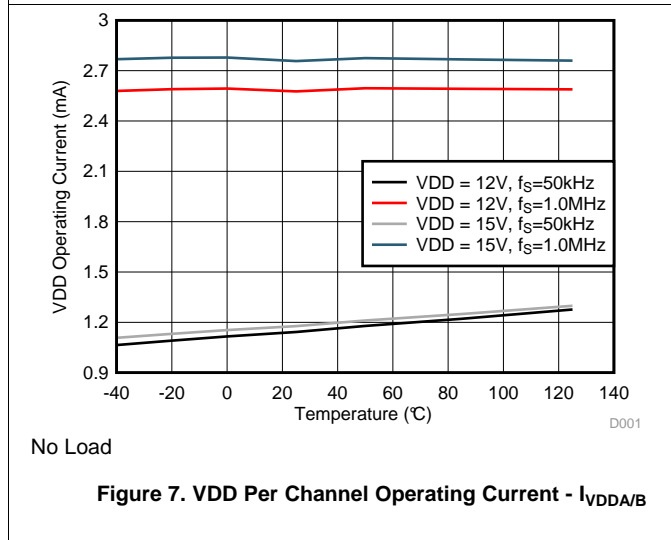
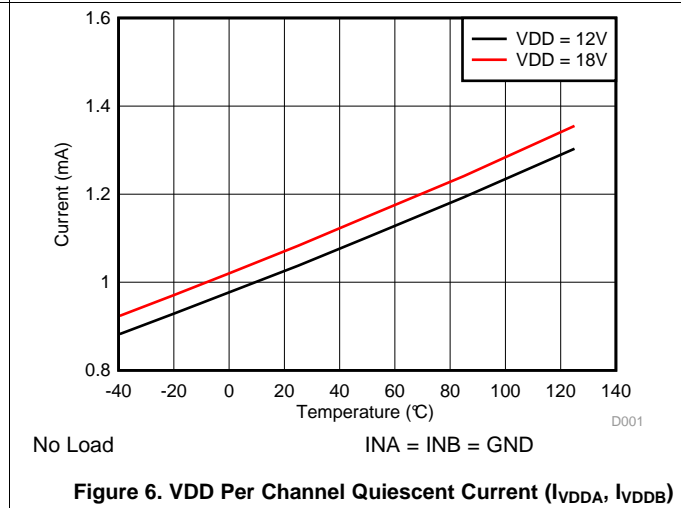
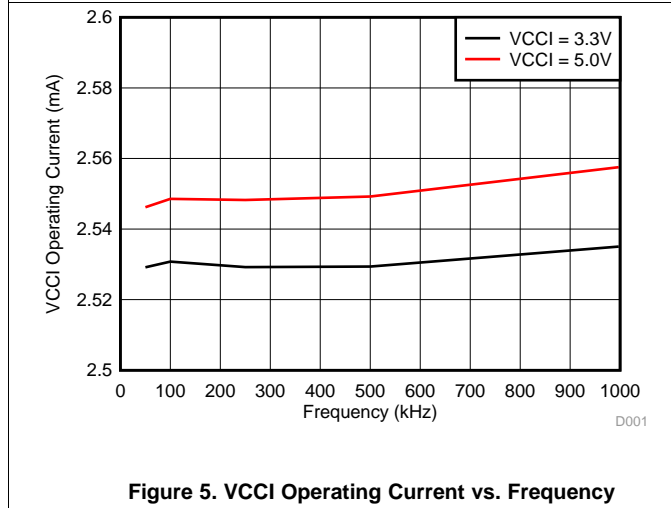
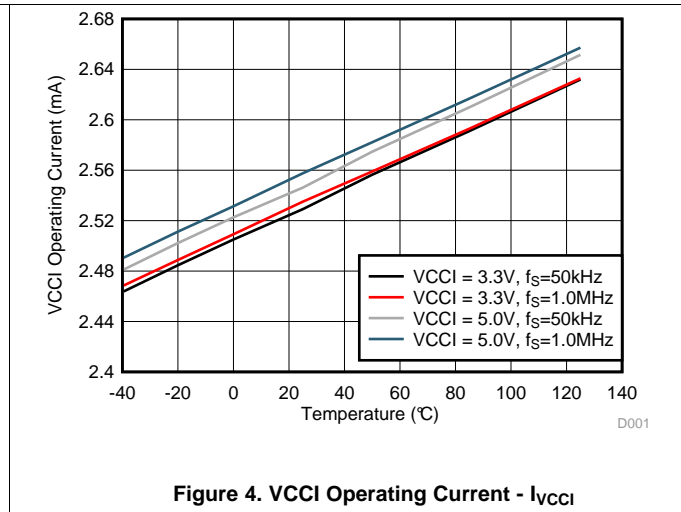
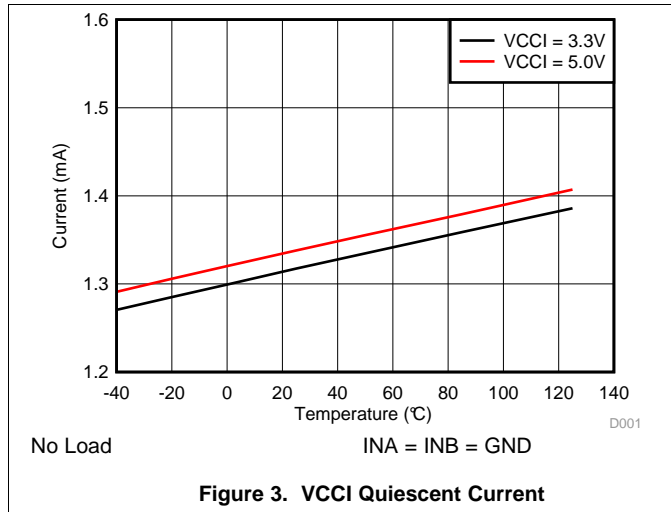
(1) Parameters with only a typical value are provided for reference only, and do not constitute part of TI's published device specifications for purposes of TI's product warranty.

### 6.11 Thermal Derating Curves



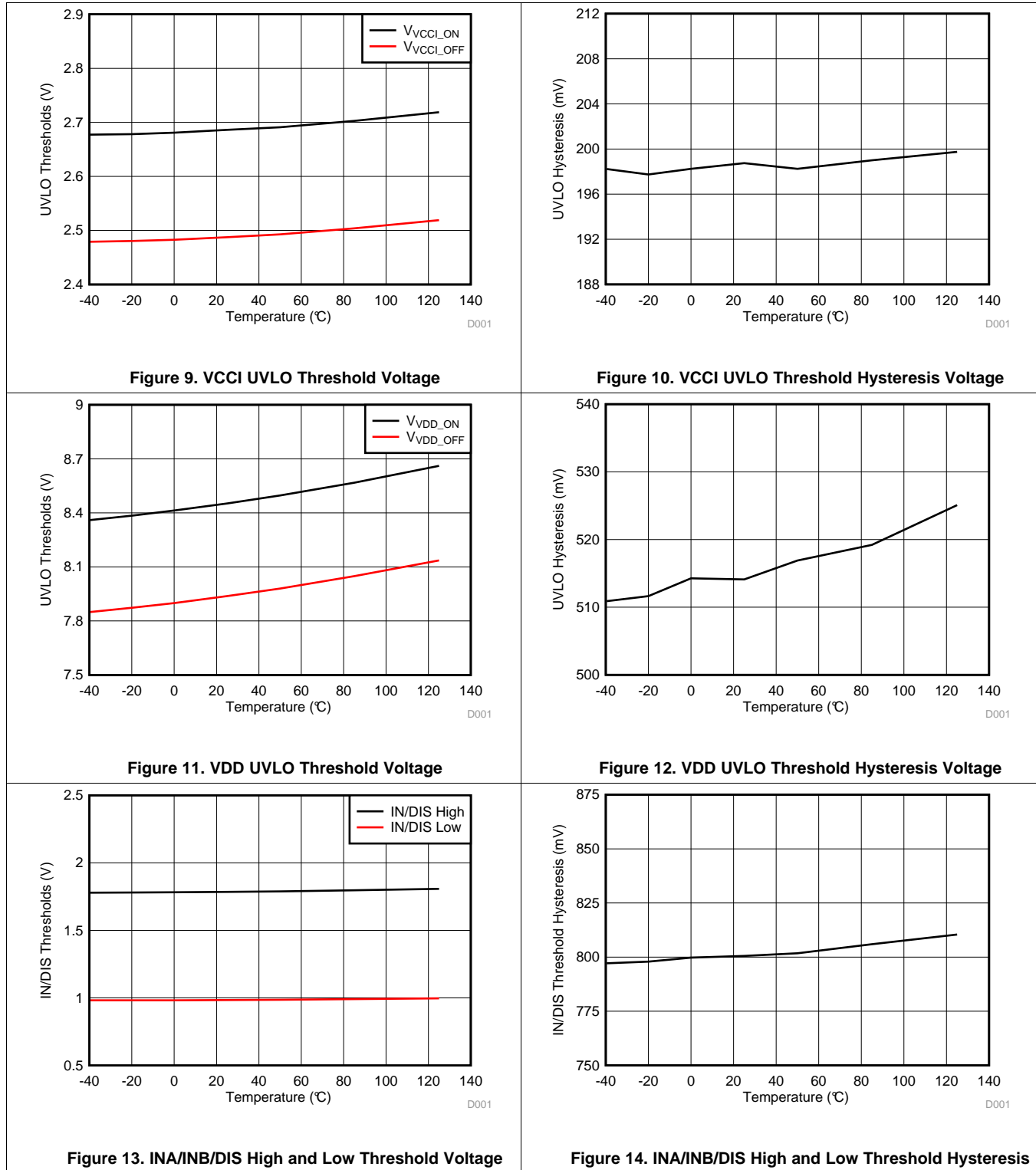
## 6.12 Typical Characteristics

VDDA = VDDB = 12 V, VCCI = 3.3 V or 5.0 V, DT pin tied to VCCI,  $T_A = 25^\circ\text{C}$ ,  $C_L = 0$  pF unless otherwise noted.



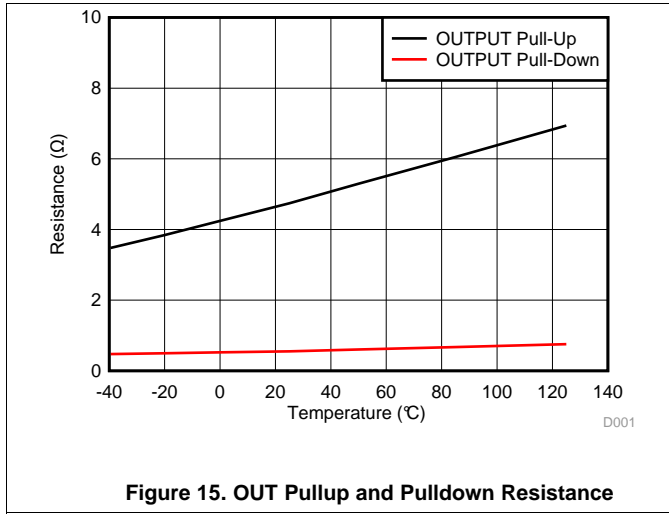
Typical Characteristics (continued)

VDDA = VDDB = 12 V, VCCI = 3.3 V or 5.0 V, DT pin tied to VCCI, T<sub>A</sub> = 25°C, C<sub>L</sub> = 0 pF unless otherwise noted.

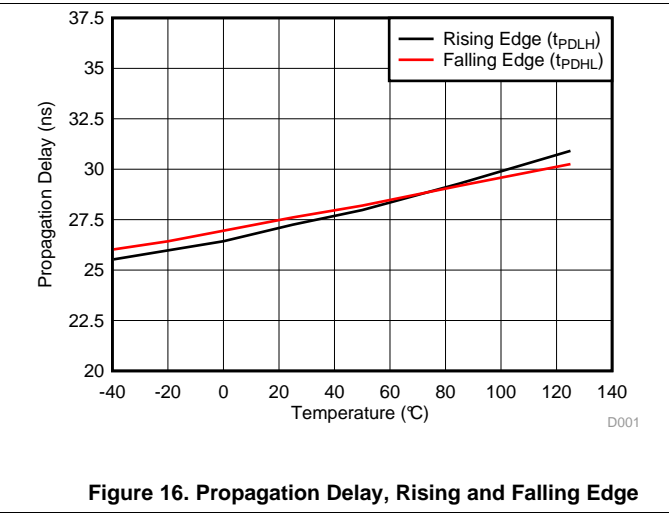


**Typical Characteristics (continued)**

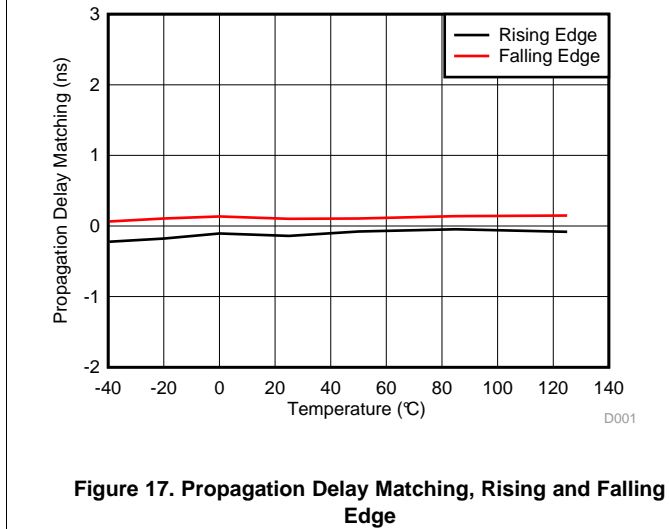
VDDA = VDDB = 12 V, VCCI = 3.3 V or 5.0 V, DT pin tied to VCCI, T<sub>A</sub> = 25°C, C<sub>L</sub> = 0 pF unless otherwise noted.



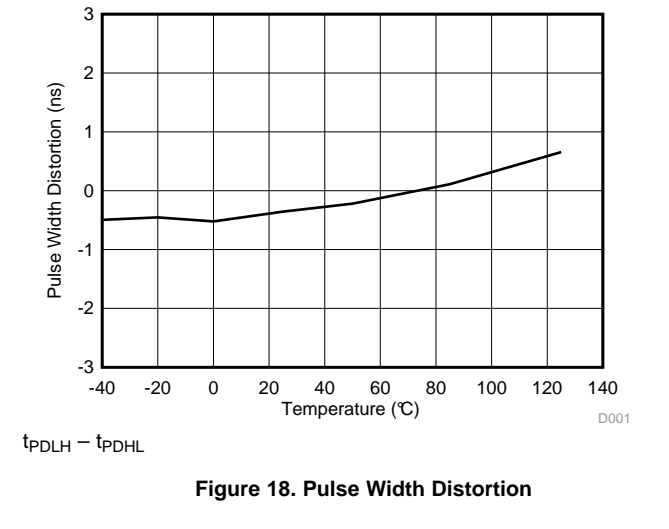
**Figure 15. OUT Pullup and Pulldown Resistance**



**Figure 16. Propagation Delay, Rising and Falling Edge**

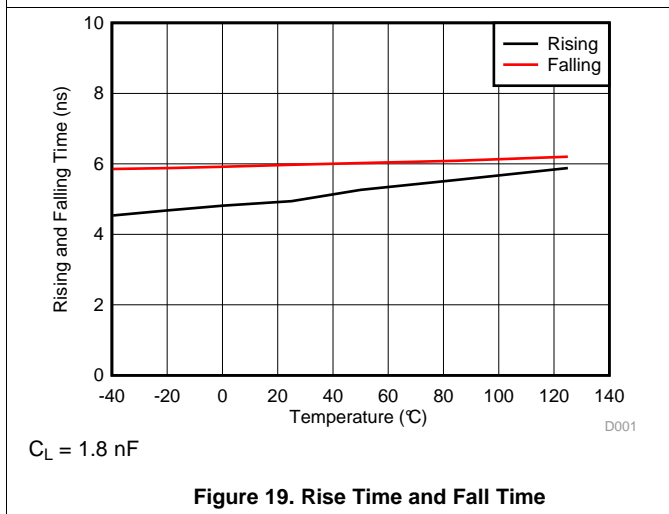


**Figure 17. Propagation Delay Matching, Rising and Falling Edge**



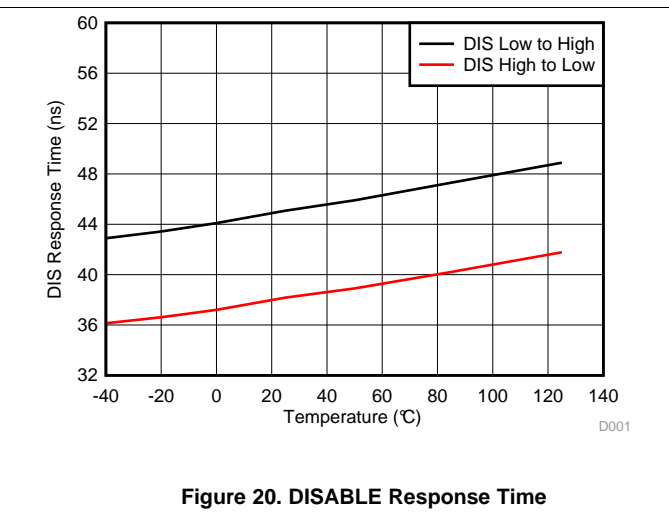
$t_{PDLH} - t_{PDHL}$

**Figure 18. Pulse Width Distortion**



C<sub>L</sub> = 1.8 nF

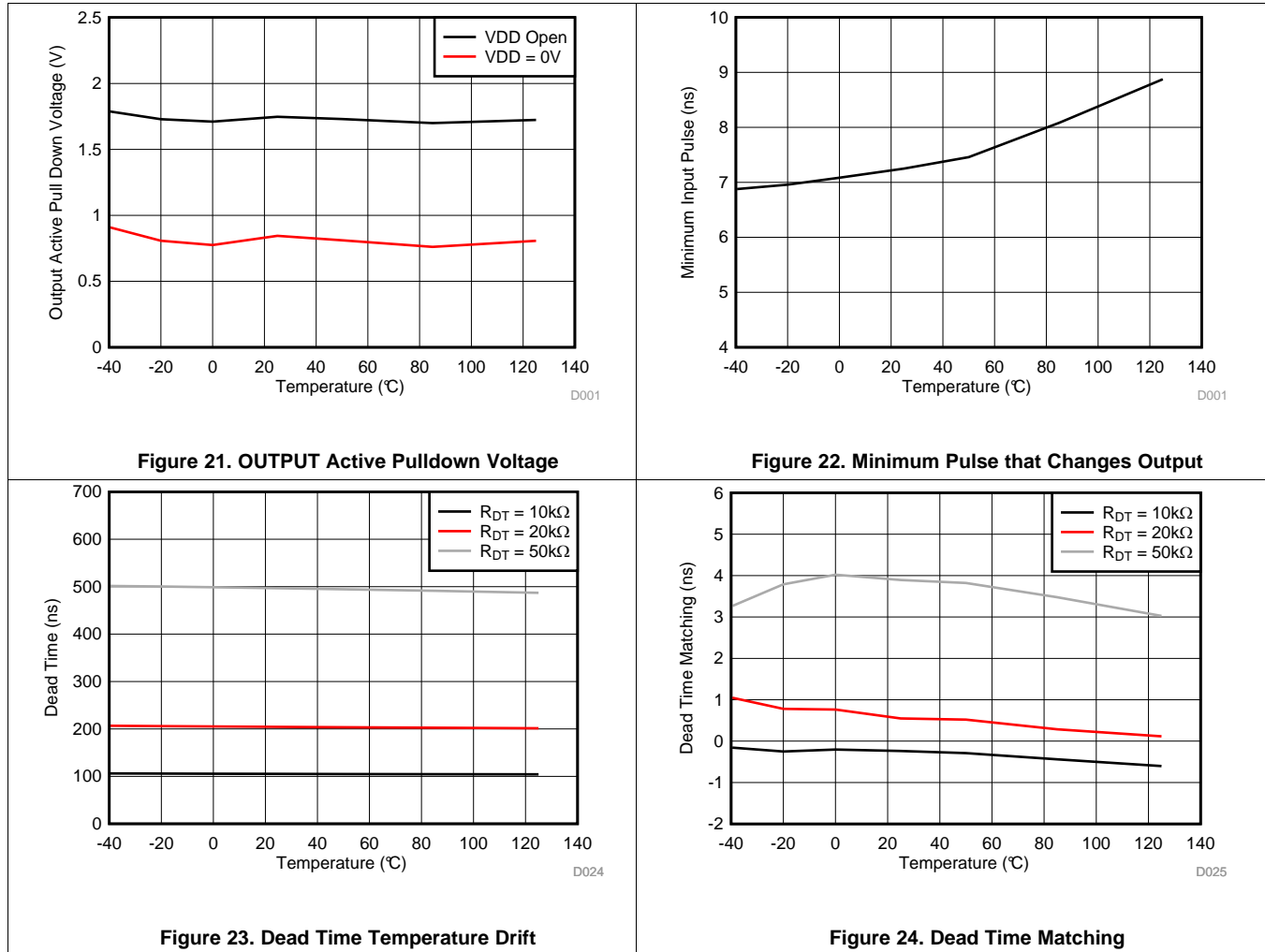
**Figure 19. Rise Time and Fall Time**



**Figure 20. DISABLE Response Time**

Typical Characteristics (continued)

VDDA = VDDb = 12 V, VCCI = 3.3 V or 5.0 V, DT pin tied to VCCI, T<sub>A</sub> = 25°C, C<sub>L</sub> = 0 pF unless otherwise noted.



## 7 Parameter Measurement Information

### 7.1 Minimum Pulses

A typical 5-ns deglitch filter removes small input pulses introduced by ground bounce or switching transients. An input pulse with duration longer than  $t_{PWmin}$ , typically 10 ns, must be asserted on INA or INB to guarantee an output state change at OUTA or OUTB. See Figure 25 and Figure 26 for detailed information of the operation of deglitch filter.

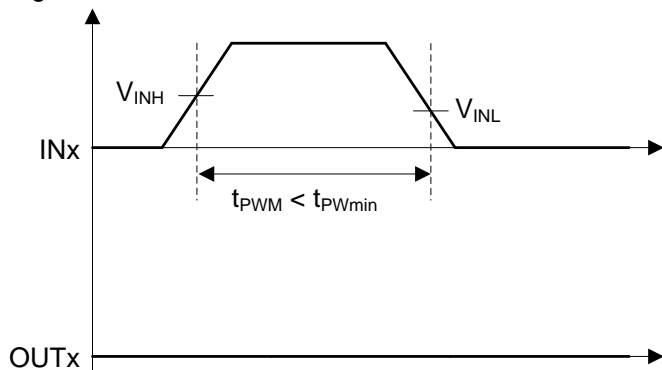


Figure 25. Deglitch Filter – Turn ON

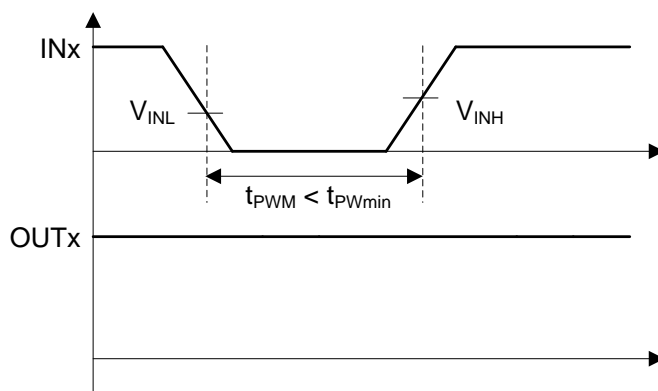


Figure 26. Deglitch Filter – Turn OFF

### 7.2 Propagation Delay and Pulse Width Distortion

Figure 27 shows calculation of pulse width distortion ( $t_{PWD}$ ) and delay matching ( $t_{DM}$ ) from the propagation delays of channels A and B. To measure delay matching, both inputs must be in phase, and the DT pin must be shorted to VCCI to enable output overlap.

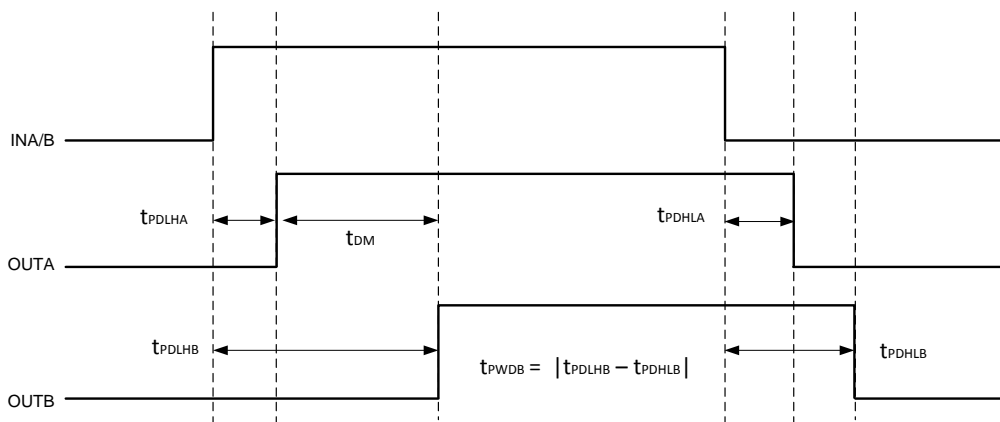
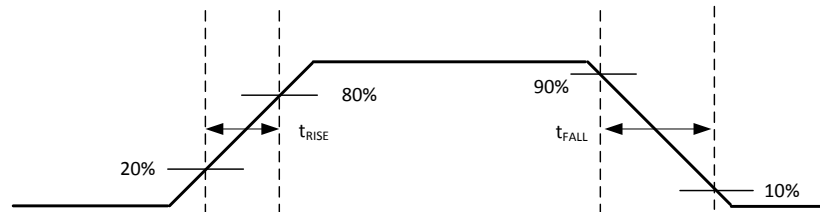


Figure 27. Delay Matching and Pulse Width Distortion

### 7.3 Rising and Falling Time

Figure 28 shows the criteria for measuring rising ( $t_{RISE}$ ) and falling ( $t_{FALL}$ ) times. For more information on how short rising and falling times are achieved see [Output Stage](#).

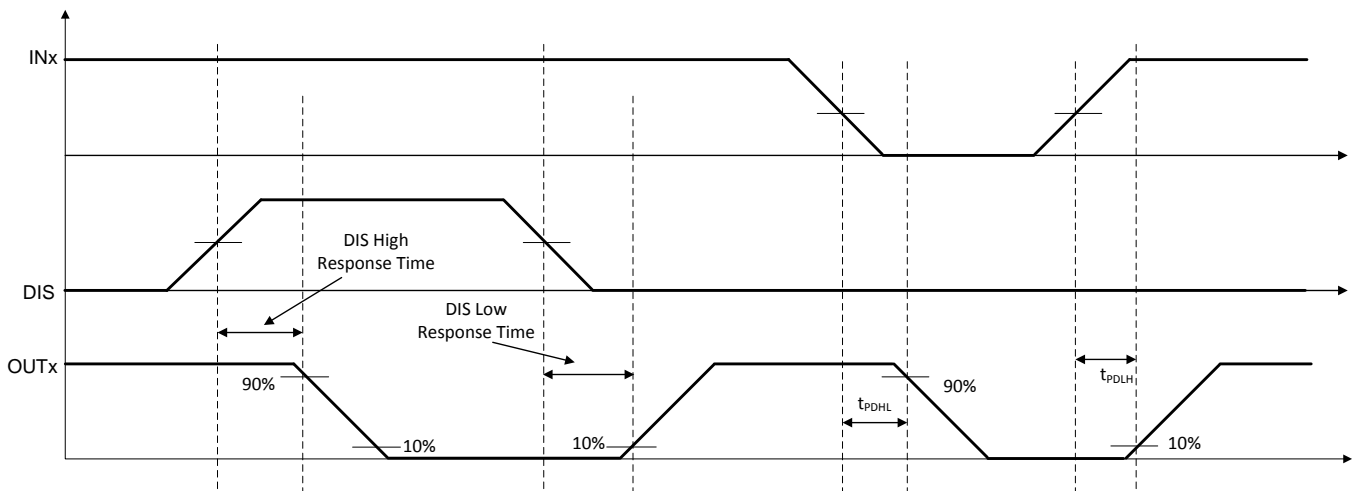
## Rising and Falling Time (continued)



**Figure 28. Rising and Falling Time Criteria**

## 7.4 Input and Disable Response Time

Figure 29 shows the response time of the disable function. For more information, see [Disable Pin](#).



**Figure 29. Disable Pin Timing**

## 7.5 Programmable Dead Time

Tying DT to VCCI or leaving DT open allows the outputs to overlap. Placing a resistor ( $R_{DT}$ ) between DT and GND adjusts dead time according to the equation:  $DT$  (in ns) =  $10 \times R_{DT}$  (in k $\Omega$ ). TI recommends bypassing this pin with a ceramic capacitor, 2.2 nF or greater, to achieve better noise immunity. Place this capacitor and  $R_{DT}$  close to the DT pin.. For more details on dead time, refer to [Programmable Dead Time \(DT\) Pin](#).

Programmable Dead Time (continued)

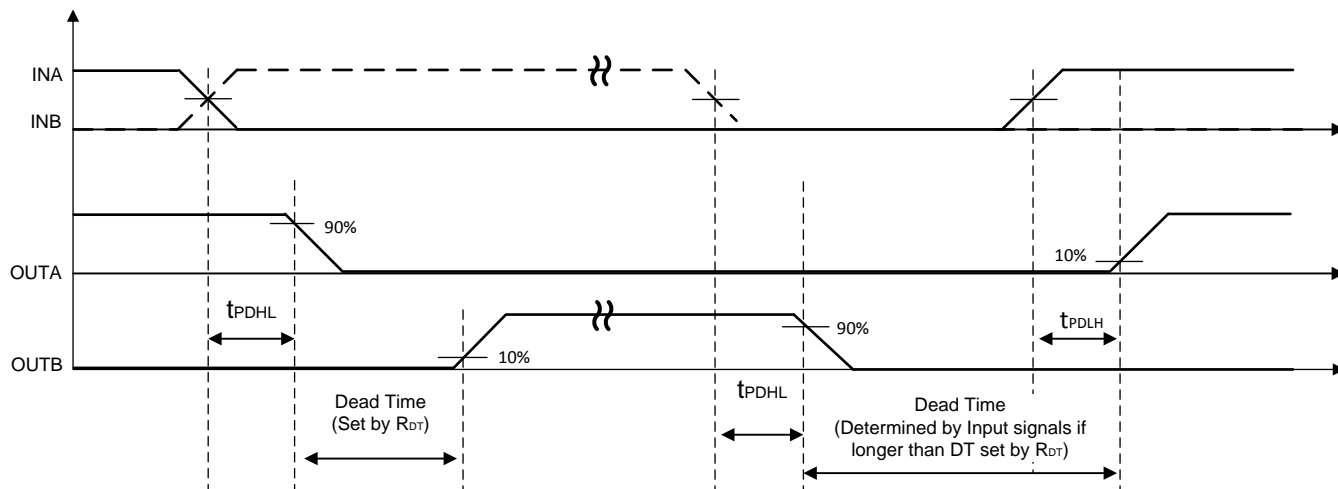


Figure 30. Dead Time Switching Parameters

7.6 Power-up UVLO Delay to OUTPUT

Whenever the supply voltage  $V_{CCI}$  crosses from below the falling threshold  $V_{VCCI\_OFF}$  to above the rising threshold  $V_{VCCI\_ON}$ , and whenever the supply voltage  $V_{DDx}$  crosses from below the falling threshold  $V_{VDDx\_OFF}$  to above the rising threshold  $V_{VDDx\_ON}$ , there is a delay before the outputs begin responding to the inputs. For  $V_{CCI}$  UVLO this delay is defined as  $t_{VCCI+ to OUT}$ , and is typically 40  $\mu s$ . For  $V_{DDx}$  UVLO this delay is defined as  $t_{VDD+ to OUT}$ , and is typically 22  $\mu s$ . TI recommends allowing some margin before driving input signals, to ensure the driver  $V_{CCI}$  and  $V_{DD}$  bias supplies are fully activated. Figure 31 and Figure 32 show the power-up UVLO delay timing diagram for  $V_{CCI}$  and  $V_{DD}$ .

Whenever the supply voltage  $V_{CCI}$  crosses below the falling threshold  $V_{VCCI\_OFF}$ , or  $V_{DDx}$  crosses below the falling threshold  $V_{VDDx\_OFF}$ , the outputs stop responding to the inputs and are held low within 1  $\mu s$ . This asymmetric delay is designed to ensure safe operation during  $V_{CCI}$  or  $V_{DDx}$  brownouts.

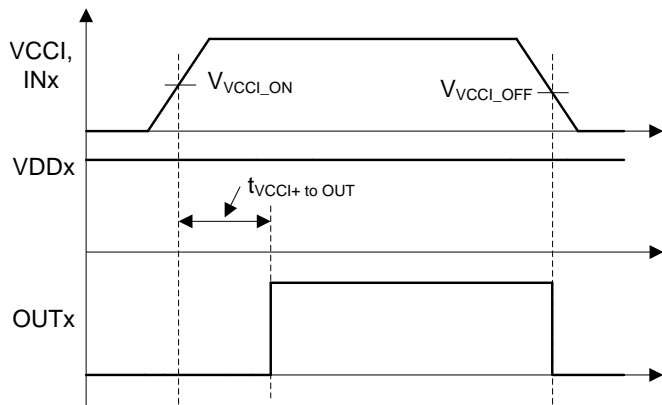


Figure 31. VCCI Power-up UVLO Delay

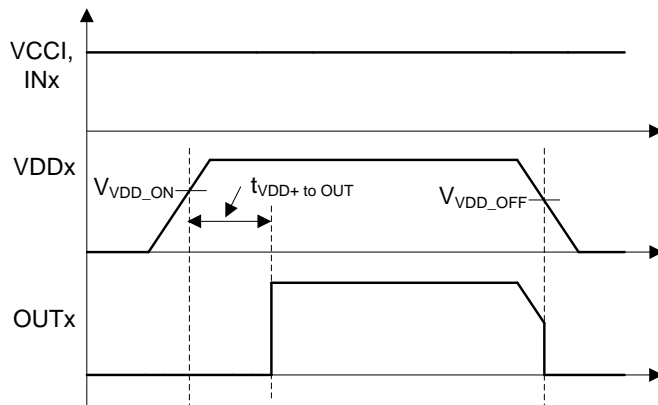
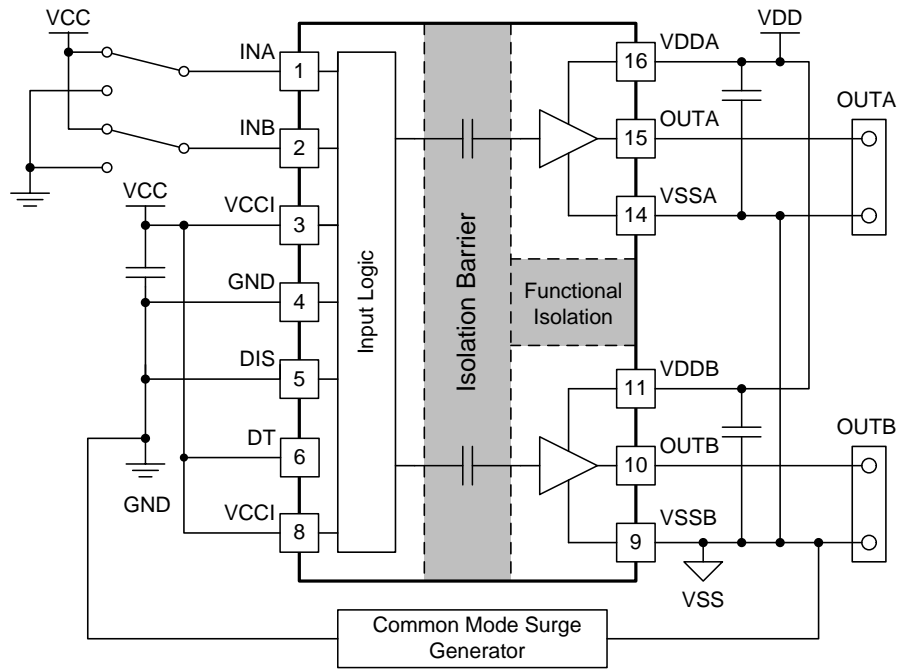


Figure 32. VDDA/B Power-up UVLO Delay

### 7.7 CMTI Testing

Figure 33 is a simplified diagram of the CMTI testing configuration.



**Figure 33. Simplified CMTI Testing Setup**

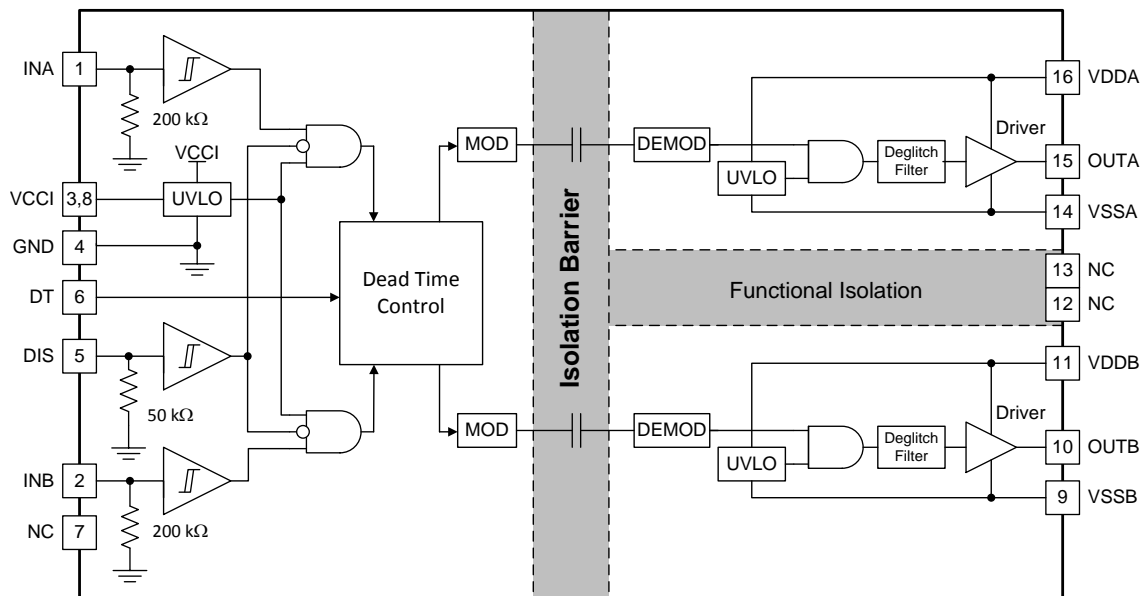
## 8 Detailed Description

### 8.1 Overview

In order to switch power transistors rapidly and reduce switching power losses, high-current gate drivers are often placed between the output of control devices and the gates of power transistors. There are several instances where controllers are not capable of delivering sufficient current to drive the gates of power transistors. This is especially the case with digital controllers, since the input signal from the digital controller is often a 3.3-V logic signal capable of only delivering a few mA.

The UCC21222 is a flexible dual gate driver which can be configured to fit a variety of power supply and motor drive topologies, as well as drive several types of transistors. The UCC21222 has many features that allow it to integrate well with control circuitry and protect the gates it drives such as: resistor-programmable dead time (DT) control, disable pin, and under voltage lock out (UVLO) for both input and output supplies. The UCC21222 also holds its outputs low when the inputs are left open or when the input pulse duration is too short. The driver inputs are CMOS and TTL compatible for interfacing with digital and analog power controllers alike. Each channel is controlled by its respective input pins (INA and INB), allowing full and independent control of each of the outputs.

### 8.2 Functional Block Diagram



Copyright © 2018, Texas Instruments Incorporated

### 8.3 Feature Description

#### 8.3.1 VDD, VCCI, and Under Voltage Lock Out (UVLO)

The UCC21222 has an internal under voltage lock out (UVLO) protection feature on each supply voltage between the VDD and VSS pins for both outputs. When the VDD bias voltage is lower than  $V_{VDD\_ON}$  at device start-up or lower than  $V_{VDD\_OFF}$  after start-up, the VDD UVLO feature holds the channel output low, regardless of the status of the input pins.

When the output stages of the driver are in an unbiased or UVLO condition, the driver outputs are held low by an active clamp circuit that limits the voltage rise on the driver outputs (illustrated in Figure 34). In this condition, the upper PMOS is resistively held off by  $R_{HI-Z}$  while the lower NMOS gate is tied to the driver output through  $R_{CLAMP}$ . In this configuration, the output is effectively clamped to the threshold voltage of the lower NMOS device, typically around 1.5V, regardless of whether bias power is available.

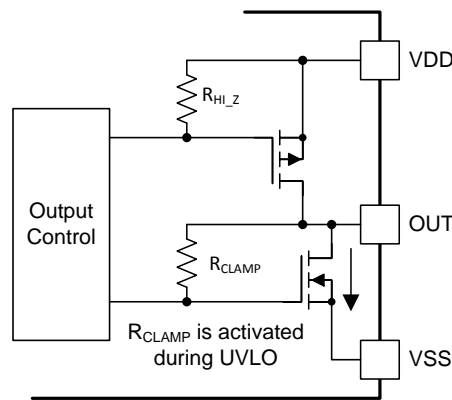


Figure 34. Simplified Representation of Active Pull Down Feature

The VDD UVLO protection has a hysteresis feature ( $V_{VDD\_HYS}$ ). This hysteresis prevents chatter when there is ground noise from the power supply. This also allows the device to accept small drops in bias voltage, which commonly occurs when the device starts switching and operating current consumption increases suddenly.

The inputs of the UCC21222 also have an internal under voltage lock out (UVLO) protection feature. The inputs cannot affect the outputs unless the supply voltage VCCI exceeds  $V_{VCCI\_ON}$  on start-up. The outputs are held low and cannot respond to inputs when the supply voltage VCCI drops below  $V_{VCCI\_OFF}$  after start-up. Like the UVLO for VDD, there is hysteresis ( $V_{VCCI\_HYS}$ ) to ensure stable operation.

Table 1. VCCI UVLO Feature Logic

CONDITION	INPUTS		OUTPUTS	
	INA	INB	OUTA	OUTB
$V_{CCI-GND} < V_{VCCI\_ON}$ during device start up	H	L	L	L
$V_{CCI-GND} < V_{VCCI\_ON}$ during device start up	L	H	L	L
$V_{CCI-GND} < V_{VCCI\_ON}$ during device start up	H	H	L	L
$V_{CCI-GND} < V_{VCCI\_ON}$ during device start up	L	L	L	L
$V_{CCI-GND} < V_{VCCI\_OFF}$ after device start up	H	L	L	L
$V_{CCI-GND} < V_{VCCI\_OFF}$ after device start up	L	H	L	L
$V_{CCI-GND} < V_{VCCI\_OFF}$ after device start up	H	H	L	L
$V_{CCI-GND} < V_{VCCI\_OFF}$ after device start up	L	L	L	L

**Table 2. VDD UVLO Feature Logic**

CONDITION	INPUTS		OUTPUTS	
	INA	INB	OUTA	OUTB
VDD-VSS < V <sub>VDD_ON</sub> during device start up	H	L	L	L
VDD-VSS < V <sub>VDD_ON</sub> during device start up	L	H	L	L
VDD-VSS < V <sub>VDD_ON</sub> during device start up	H	H	L	L
VDD-VSS < V <sub>VDD_ON</sub> during device start up	L	L	L	L
VDD-VSS < V <sub>VDD_OFF</sub> after device start up	H	L	L	L
VDD-VSS < V <sub>VDD_OFF</sub> after device start up	L	H	L	L
VDD-VSS < V <sub>VDD_OFF</sub> after device start up	H	H	L	L
VDD-VSS < V <sub>VDD_OFF</sub> after device start up	L	L	L	L

### 8.3.2 Input and Output Logic Table

Assume VCCI, VDDA, VDDB are powered up (see [VDD](#), [VCCI](#), and [Under Voltage Lock Out \(UVLO\)](#) for more information on UVLO operation modes). [Table 3](#) shows the operation with INA, INB and DIS and the corresponding output state.

**Table 3. INPUT/OUTPUT Logic Table<sup>(1)</sup>**

INPUTS		DIS	OUTPUTS		NOTE
INA	INB		OUTA	OUTB	
L	L	L or Left Open	L	L	If the dead time function is used, output transitions occur after the dead time expires. See <a href="#">Programmable Dead Time (DT) Pin</a> .
L	H	L or Left Open	L	H	
H	L	L or Left Open	H	L	
H	H	L or Left Open	L	L	DT is programmed with R <sub>DT</sub> .
H	H	L or Left Open	H	H	DT pin is left open or pulled to VCCI.
Left Open	Left Open	L or Left Open	L	L	
X	X	H	L	L	

(1) "X" means L, H or left open. For improved noise immunity, TI recommends connecting INA, INB, and DIS to GND, and DT to VCCI, when these pins are not used.

### 8.3.3 Input Stage

The input pins (INA, INB, and DIS) of the UCC21222 are based on a TTL and CMOS compatible input-threshold logic that is totally isolated from the VDD supply voltage of the output channels. The input pins are easy to drive with logic-level control signals (such as those from 3.3-V microcontrollers), since the UCC21222 has a typical high threshold (V<sub>INAH</sub>) of 1.8 V and a typical low threshold of 1 V, which vary little with temperature (see [Figure 11](#) and [Figure 13](#)). A wide hysteresis (V<sub>INA\_HYS</sub>) of 0.8 V makes for good noise immunity and stable operation. If any of the inputs are ever left open, internal pull-down resistors force the pin low. These resistors are typically 200 kΩ for INA/B and 50 kΩ for DIS (see [Functional Block Diagram](#)). TI recommends grounding any unused inputs.

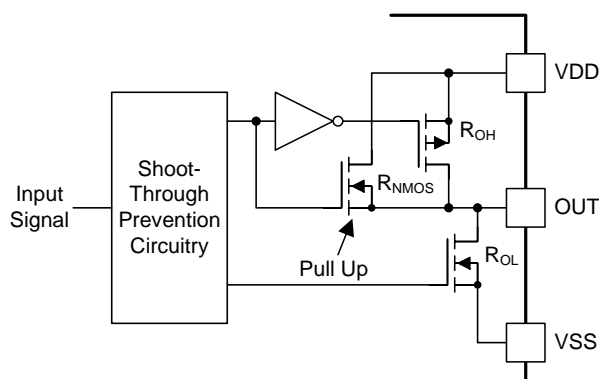
The amplitude of any signal applied to the inputs must *never* be at a voltage higher than VCCI.

### 8.3.4 Output Stage

The UCC21222 output stage features a pull-up structure which delivers the highest peak-source current when it is most needed: during the Miller plateau region of the power-switch turn on transition (when the power switch drain or collector voltage experiences  $dV/dt$ ). The output stage pull-up structure features a P-channel MOSFET and an additional *pull-up* N-channel MOSFET in parallel. The function of the N-channel MOSFET is to provide a boost in the peak-sourcing current, enabling fast turn on. This is accomplished by briefly turning on the N-channel MOSFET during a narrow instant when the output is changing states from low to high. The on-resistance of this N-channel MOSFET ( $R_{NMOS}$ ) is approximately  $1.47\ \Omega$  when activated.

The  $R_{OH}$  parameter is a DC measurement and it is representative of the on-resistance of the P-channel device only. This is because the *pull-up* N-channel device is held in the off state in DC condition and is turned on only for a brief instant when the output is changing states from low to high. Therefore the effective resistance of the UCC21222 pull-up stage during this brief turn-on phase is much lower than what is represented by the  $R_{OH}$  parameter.

The pull-down structure of the UCC21222 is composed of an N-channel MOSFET. The  $R_{OL}$  parameter, which is also a DC measurement, is representative of the impedance of the pull-down state in the device. Both outputs of the UCC21222 are capable of delivering 4-A peak source and 6-A peak sink current pulses. The output voltage swings between VDD and VSS for rail-to-rail operation.



**Figure 35. Output Stage**

### 8.3.5 Diode Structure in the UCC21222

Figure 36 illustrates the multiple diodes involved in the ESD protection components. This provides a pictorial representation of the absolute maximum rating for the device.

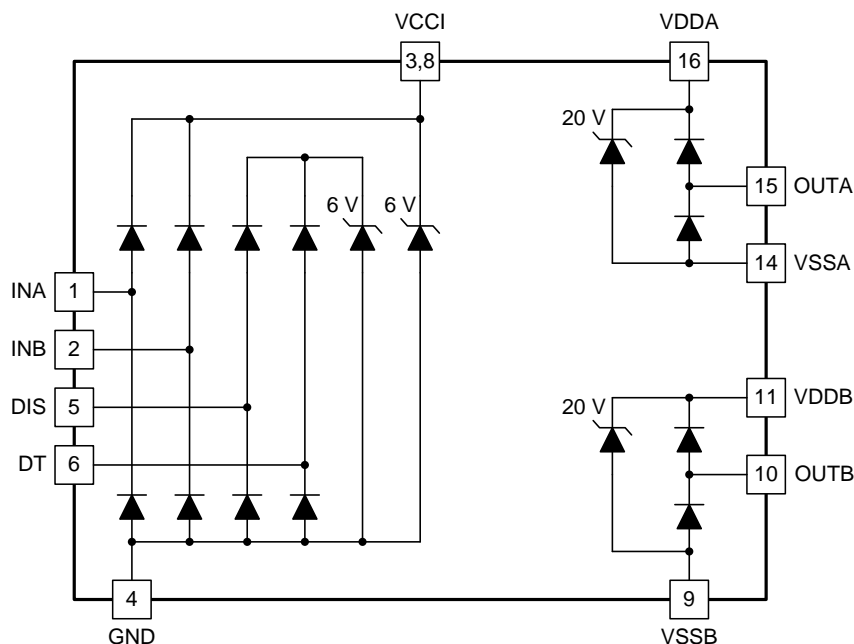


Figure 36. ESD Structure

## 8.4 Device Functional Modes

### 8.4.1 Disable Pin

When the DIS pin is set high, both outputs are shut down simultaneously. When the DIS pin is set low or left open, the UCC21222 operates normally. The DIS circuit logic structure is nearly identical compared to INA or INB, and the propagation delay is similar (see Figure 20). The DIS pin is only functional (and necessary) when VCCI stays above the UVLO threshold. It is recommended to tie this pin to GND if the DIS pin is not used to achieve better noise immunity.

### 8.4.2 Programmable Dead Time (DT) Pin

The UCC21222 allows the user to adjust dead time (DT) in the following ways:

#### 8.4.2.1 DT Pin Tied to VCCI or DT Pin Left Open

Outputs completely match inputs, so no minimum dead time is asserted. This allows the outputs to overlap. TI recommends connecting this pin directly to VCCI if it is not used to achieve better noise immunity.

#### 8.4.2.2 Connecting a Programming Resistor between DT and GND Pins

Program  $t_{DT}$  by placing a resistor,  $R_{DT}$ , between the DT pin and GND. The appropriate  $R_{DT}$  value can be determined from:

$$t_{DT} \approx 10 \times R_{DT}$$

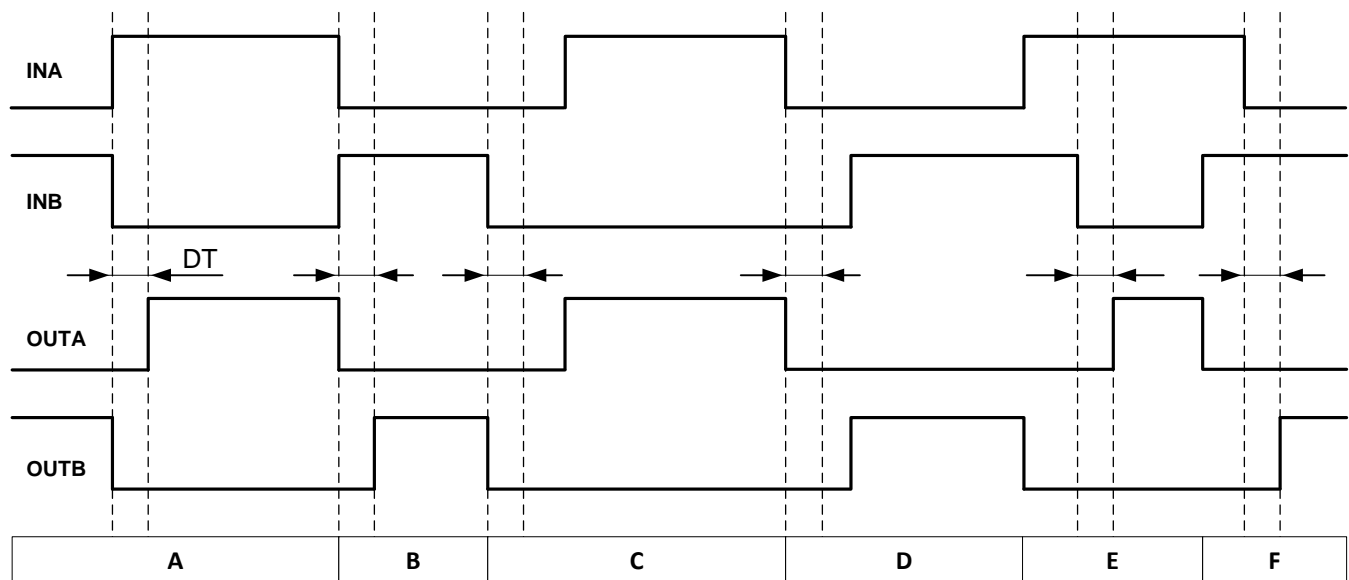
where

- $t_{DT}$  is the programmed dead time, in nanoseconds.
- $R_{DT}$  is the value of resistance between DT pin and GND, in kilo-ohms. (1)

## Device Functional Modes (continued)

The steady state voltage at the DT pin is about 0.8 V.  $R_{DT}$  programs a small current at this pin, which sets the dead time. As the value of  $R_{DT}$  increases, the current sourced by the DT pin decreases. The DT pin current will be less than 10  $\mu\text{A}$  when  $R_{DT} = 100 \text{ k}\Omega$ . For larger values of  $R_{DT}$ , TI recommends placing  $R_{DT}$  and a ceramic capacitor, 2.2 nF or greater, as close to the DT pin as possible to achieve greater noise immunity and better dead time matching between both channels.

The falling edge of an input signal initiates the programmed dead time for the other signal. The programmed dead time is the minimum enforced duration in which both outputs are held low by the driver. The outputs may also be held low for a duration greater than the programmed dead time, if the INA and INB signals include a dead time duration greater than the programmed minimum. If both inputs are high simultaneously, both outputs will immediately be set low. This feature is used to prevent shoot-through in half-bridge applications, and it does not affect the programmed dead time setting for normal operation. Various driver dead time logic operating conditions are illustrated and explained in [Figure 37](#).



**Figure 37. Input and Output Logic Relationship with Input Signals**

**Condition A:** INB goes low, INA goes high. INB sets OUTB low immediately and assigns the programmed dead time to OUTA. OUTA is allowed to go high after the programmed dead time.

**Condition B:** INB goes high, INA goes low. Now INA sets OUTA low immediately and assigns the programmed dead time to OUTB. OUTB is allowed to go high after the programmed dead time.

**Condition C:** INB goes low, INA is still low. INB sets OUTB low immediately and assigns the programmed dead time for OUTA. In this case, the input signal dead time is longer than the programmed dead time. When INA goes high after the duration of the input signal dead time, it immediately sets OUTA high.

**Condition D:** INA goes low, INB is still low. INA sets OUTA low immediately and assigns the programmed dead time to OUTB. In this case, the input signal dead time is longer than the programmed dead time. When INB goes high after the duration of the input signal dead time, it immediately sets OUTB high.

**Condition E:** INA goes high, while INB and OUTB are still high. To avoid overshoot, OUTB is immediately pulled low. After some time OUTB goes low and assigns the programmed dead time to OUTA. OUTA is already low. After the programmed dead time, OUTA is allowed to go high.

**Condition F:** INB goes high, while INA and OUTA are still high. To avoid overshoot, OUTA is immediately pulled low. After some time OUTA goes low and assigns the programmed dead time to OUTB. OUTA is already low. After the programmed dead time, OUTB is allowed to go high.

## 9 Application and Implementation

### NOTE

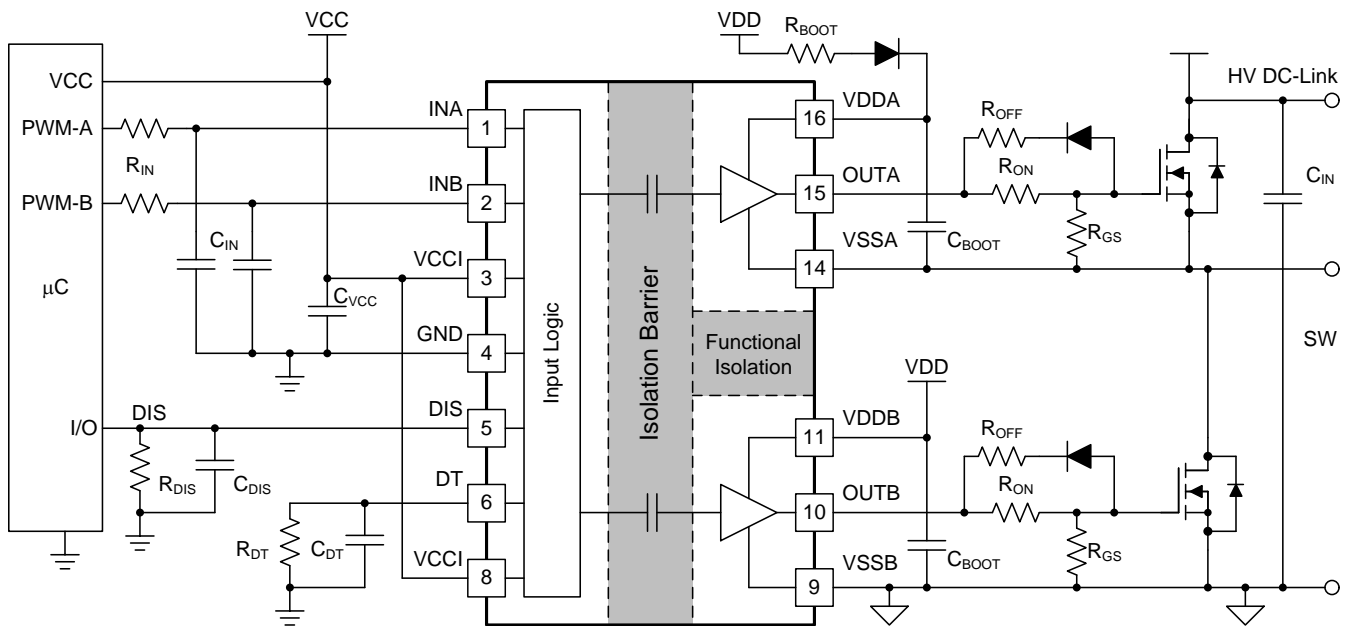
Information in the following applications sections is not part of the TI component specification, and TI does not warrant its accuracy or completeness. TI's customers are responsible for determining suitability of components for their purposes. Customers should validate and test their design implementation to confirm system functionality.

### 9.1 Application Information

The UCC21222 effectively combines both isolation and buffer-drive functions. The flexible, universal capability of the UCC21222 (with up to 5.5-V VCCI and 18-V VDDA/VDDB) allows the device to be used as a low-side, high-side, high-side/low-side or half-bridge driver for MOSFETs, IGBTs or GaN transistor. With integrated components, advanced protection features (UVLO, dead time, and disable) and optimized switching performance, the UCC21222 enables designers to build smaller, more robust designs for enterprise, telecom, automotive, and industrial applications with a faster time to market.

### 9.2 Typical Application

The circuit in [Figure 38](#) shows a reference design with the UCC21222 driving a typical half-bridge configuration which could be used in several popular power converter topologies such as synchronous buck, synchronous boost, half-bridge/full bridge isolated topologies, and 3-phase motor drive applications.



Copyright © 2018, Texas Instruments Incorporated

Figure 38. Typical Application Schematic

## Typical Application (continued)

### 9.2.1 Design Requirements

Table 4 lists reference design parameters for the example application: UCC21222 driving 650-V MOSFETs in a high side-low side configuration.

**Table 4. UCC21222 Design Requirements**

PARAMETER	VALUE	UNITS
Power transistor	650-V, 150-mΩ $R_{DS\_ON}$ with 12-V $V_{GS}$	-
VCC	5.0	V
VDD	12	V
Input signal amplitude	3.3	V
Switching frequency ( $f_s$ )	100	kHz
Dead Time	200	ns
DC link voltage	400	V

### 9.2.2 Detailed Design Procedure

#### 9.2.2.1 Custom Design With WEBENCH® Tools

[Click here](#) to create a custom design using the UCC21222 device with the WEBENCH® Power Designer.

1. Start by entering the input voltage ( $V_{IN}$ ), output voltage ( $V_{OUT}$ ), and output current ( $I_{OUT}$ ) requirements.
2. Optimize the design for key parameters such as efficiency, footprint, and cost using the optimizer dial.
3. Compare the generated design with other possible solutions from Texas Instruments.

The WEBENCH Power Designer provides a customized schematic along with a list of materials with real-time pricing and component availability.

In most cases, these actions are available:

- Run electrical simulations to see important waveforms and circuit performance
- Run thermal simulations to understand board thermal performance
- Export customized schematic and layout into popular CAD formats
- Print PDF reports for the design, and share the design with colleagues

Get more information about WEBENCH tools at [www.ti.com/WEBENCH](http://www.ti.com/WEBENCH).

#### 9.2.2.2 Designing INA/INB Input Filter

It is recommended that users avoid shaping the signals to the gate driver in an attempt to slow down (or delay) the signal at the output. However, a small input  $R_{IN}$ - $C_{IN}$  filter can be used to filter out the ringing introduced by non-ideal layout or long PCB traces.

Such a filter should use an  $R_{IN}$  in the range of 0 Ω to 100 Ω and a  $C_{IN}$  between 10 pF and 100 pF. In the example, an  $R_{IN} = 51$  Ω and a  $C_{IN} = 33$  pF are selected, with a corner frequency of approximately 100 MHz.

When selecting these components, it is important to pay attention to the trade-off between good noise immunity and propagation delay.

#### 9.2.2.3 Select Dead Time Resistor and Capacitor

From [Equation 1](#), a 20-kΩ resistor is selected to set the dead time to 200 ns. A 2.2-nF capacitor is placed in parallel close to the DT pin to improve noise immunity.

#### 9.2.2.4 Select External Bootstrap Diode and its Series Resistor

The bootstrap capacitor is charged by VDD through an external bootstrap diode every cycle when the low side transistor turns on. Charging the capacitor involves high-peak currents, and therefore transient power dissipation in the bootstrap diode may be significant. Conduction loss also depends on the diode's forward voltage drop. Both the diode conduction losses and reverse recovery losses contribute to the total losses in the gate driver circuit.

When selecting external bootstrap diodes, it is recommended that one choose high voltage, fast recovery diodes or SiC Schottky diodes with a low forward voltage drop and low junction capacitance in order to minimize the loss introduced by reverse recovery and related grounding noise bouncing. In the example, the DC-link voltage is 400 V<sub>DC</sub>. The voltage rating of the bootstrap diode should be higher than the DC-link voltage with a good margin. Therefore, a 600-V ultrafast diode, MURA160T3G, is chosen in this example.

A bootstrap resistor, R<sub>BOOT</sub>, is used to reduce the inrush current in D<sub>BOOT</sub> and limit the ramp up slew rate of voltage of VDDA-VSSA during each switching cycle, especially when the VSSA(SW) pin has an excessive negative transient voltage. The recommended value for R<sub>BOOT</sub> is between 1 Ω and 20 Ω depending on the diode used. In the example, a current limiting resistor of 2.2 Ω is selected to limit the inrush current of bootstrap diode. The estimated worst case peak current through D<sub>Boot</sub> is,

$$I_{DBoot(pk)} = \frac{V_{DD} - V_{BDF}}{R_{Boot}} = \frac{12V - 1.5V}{2.7\Omega} \approx 4A$$

where

- V<sub>BDF</sub> is the estimated bootstrap diode forward voltage drop around 4 A. (2)

### 9.2.2.5 Gate Driver Output Resistor

The external gate driver resistors,  $R_{ON}/R_{OFF}$ , are used to:

1. Limit ringing caused by parasitic inductances/capacitances.
2. Limit ringing caused by high voltage/current switching  $dv/dt$ ,  $di/dt$ , and body-diode reverse recovery.
3. Fine-tune gate drive strength, i.e. peak sink and source current to optimize the switching loss.
4. Reduce electromagnetic interference (EMI).

As mentioned in [Output Stage](#), the UCC21222 has a pull-up structure with a P-channel MOSFET and an additional *pull-up* N-channel MOSFET in parallel. The combined peak source current is 4 A. Therefore, the peak source current can be predicted with:

$$I_{OA+} = \min \left( 4A, \frac{V_{DD} - V_{BDF}}{R_{NMOS} \parallel R_{OH} + R_{ON} + R_{GFET\_Int}} \right) \quad (3)$$

$$I_{OB+} = \min \left( 4A, \frac{V_{DD}}{R_{NMOS} \parallel R_{OH} + R_{ON} + R_{GFET\_Int}} \right)$$

where

- $R_{ON}$ : External turn-on resistance.
- $R_{GFET\_INT}$ : Power transistor internal gate resistance, found in the power transistor datasheet.
- $I_{O+}$  = Peak source current – The minimum value between 4 A, the gate driver peak source current, and the calculated value based on the gate drive loop resistance. (4)

In this example:

$$I_{OA+} = \frac{V_{DD} - V_{BDF}}{R_{NMOS} \parallel R_{OH} + R_{ON} + R_{GFET\_Int}} = \frac{12V - 0.8V}{1.47\Omega \parallel 5\Omega + 2.2\Omega + 1.5\Omega} \approx 2.3A \quad (5)$$

$$I_{OB+} = \frac{V_{DD}}{R_{NMOS} \parallel R_{OH} + R_{ON} + R_{GFET\_Int}} = \frac{12V}{1.47\Omega \parallel 5\Omega + 2.2\Omega + 1.5\Omega} \approx 2.5A \quad (6)$$

Therefore, the high-side and low-side peak source current is 2.3 A and 2.5 A respectively. Similarly, the peak sink current can be calculated with:

$$I_{OA-} = \min \left( 6A, \frac{V_{DD} - V_{BDF} - V_{GDF}}{R_{OL} + R_{OFF} \parallel R_{ON} + R_{GFET\_Int}} \right) \quad (7)$$

$$I_{OB-} = \min \left( 6A, \frac{V_{DD} - V_{GDF}}{R_{OL} + R_{OFF} \parallel R_{ON} + R_{GFET\_Int}} \right)$$

where

- $R_{OFF}$ : External turn-off resistance,  $R_{OFF}=0$  in this example;
- $V_{GDF}$ : The anti-parallel diode forward voltage drop which is in series with  $R_{OFF}$ . The diode in this example is an MSS1P4.
- $I_{O-}$ : Peak sink current – the minimum value between 6 A, the gate driver peak sink current, and the calculated value based on the gate drive loop resistance. (8)

In this example,

$$I_{OA-} = \frac{V_{DD} - V_{BDF} - V_{GDF}}{R_{OL} + R_{OFF} \parallel R_{ON} + R_{GFET\_Int}} = \frac{12V - 0.8V - 0.85V}{0.55\Omega + 0\Omega + 1.5\Omega} \approx 5.0A \quad (9)$$

$$I_{OB-} = \frac{V_{DD} - V_{GDF}}{R_{OL} + R_{OFF} \parallel R_{ON} + R_{GFET\_Int}} = \frac{12V - 0.85V}{0.55\Omega + 0\Omega + 1.5\Omega} \approx 5.4A \quad (10)$$

Therefore, the high-side and low-side peak sink current is 5.0 A and 5.4A respectively.

Importantly, the estimated peak current is also influenced by PCB layout and load capacitance. Parasitic inductance in the gate driver loop can slow down the peak gate drive current and introduce overshoot and undershoot. Therefore, it is strongly recommended that the gate driver loop should be minimized. On the other hand, the peak source/sink current is dominated by loop parasitics when the load capacitance ( $C_{ISS}$ ) of the power transistor is very small (typically less than 1 nF), because the rising and falling time is too small and close to the parasitic ringing period.

### 9.2.2.6 Estimating Gate Driver Power Loss

The total loss,  $P_G$ , in the gate driver subsystem includes the power losses of the UCC21222 ( $P_{GD}$ ) and the power losses in the peripheral circuitry, such as the external gate drive resistor. Bootstrap diode loss is not included in  $P_G$  and not discussed in this section.

$P_{GD}$  is the key power loss which determines the thermal safety-related limits of the UCC21222, and it can be estimated by calculating losses from several components.

The first component is the static power loss,  $P_{GDQ}$ , which includes quiescent power loss on the driver as well as driver self-power consumption when operating with a certain switching frequency.  $P_{GDQ}$  is measured on the bench with no load connected to OUTA and OUTB at a given  $V_{CCI}$ ,  $V_{DDA}/V_{DDB}$ , switching frequency and ambient temperature. [Figure 5](#) and [Figure 8](#) show the operating current consumption vs. operating frequency with no load. In this example,  $V_{CCI} = 5\text{ V}$  and  $V_{VDD} = 12\text{ V}$ . The current on each power supply, with INA/INB switching from 0 V to 3.3 V at 100 kHz is measured to be  $I_{VCCI} \approx 2.5\text{ mA}$ , and  $I_{VDDA} = I_{VDDB} \approx 1.5\text{ mA}$ . Therefore, the  $P_{GDQ}$  can be calculated with

$$P_{GDQ} = V_{VCCI} \times I_{VCCI} + V_{VDDA} \times I_{DDA} + V_{VDDB} \times I_{DDB} = 50\text{mW} \quad (11)$$

The second component is switching operation loss,  $P_{GDO}$ , with a given load capacitance which the driver charges and discharges the load during each switching cycle. Total dynamic loss due to load switching,  $P_{GSW}$ , can be estimated with

$$P_{GSW} = 2 \times V_{DD} \times Q_G \times f_{SW}$$

where

- $Q_G$  is the gate charge of the power transistor. (12)

If a split rail is used to turn on and turn off, then  $V_{DD}$  is going to be equal to difference between the positive rail to the negative rail.

So, for this example application:

$$P_{GSW} = 2 \times 12V \times 100\text{nC} \times 100\text{kHz} = 240\text{mW} \quad (13)$$

$Q_G$  represents the total gate charge of the power transistor switching 480 V at 14 A provided by the datasheet, and is subject to change with different testing conditions. The UCC21222 gate driver loss on the output stage,  $P_{GDO}$ , is part of  $P_{GSW}$ .  $P_{GDO}$  will be equal to  $P_{GSW}$  if the external gate driver resistances are zero, and all the gate driver loss is dissipated inside the UCC21222. If there are external turn-on and turn-off resistances, the total loss will be distributed between the gate driver pull-up/down resistances and external gate resistances. Importantly, the pull-up/down resistance is a linear and fixed resistance if the source/sink current is not saturated to 4 A/6 A, however, it will be non-linear if the source/sink current is saturated. Therefore,  $P_{GDO}$  is different in these two scenarios.

### Case 1 - Linear Pull-Up/Down Resistor:

$$P_{GDO} = \frac{P_{GSW}}{2} \times \left( \frac{R_{OH} \parallel R_{NMOS}}{R_{OH} \parallel R_{NMOS} + R_{ON} + R_{GFET\_Int}} + \frac{R_{OL}}{R_{OL} + R_{OFF} \parallel R_{ON} + R_{GFET\_Int}} \right) \quad (14)$$

In this design example, all the predicted source/sink currents are less than 4 A/6 A, therefore, the the UCC21222 gate driver loss can be estimated with:

$$P_{GDO} = \frac{240mW}{2} \times \left( \frac{5\Omega \parallel 1.47\Omega}{5\Omega \parallel 1.47\Omega + 2.2\Omega + 1.5\Omega} + \frac{0.55\Omega}{0.55\Omega + 0\Omega + 1.5\Omega} \right) \approx 60mW \quad (15)$$

### Case 2 - Nonlinear Pull-Up/Down Resistor:

$$P_{GDO} = 2 \times f_{SW} \times \left[ 4A \times \int_0^{T_{R\_Sys}} (V_{DD} - V_{OUTA/B}(t)) dt + 6A \times \int_0^{T_{F\_Sys}} V_{OUTA/B}(t) dt \right]$$

where

- $V_{OUTA/B}(t)$  is the gate driver OUTA and OUTB pin voltage during the turn on and off transient, and it can be simplified that a constant current source (4 A at turn-on and 6 A at turn-off) is charging/discharging a load capacitor. Then, the  $V_{OUTA/B}(t)$  waveform will be linear and the  $T_{R\_Sys}$  and  $T_{F\_Sys}$  can be easily predicted. (16)

For some scenarios, if only one of the pull-up or pull-down circuits is saturated and another one is not, the  $P_{GDO}$  will be a combination of Case 1 and Case 2, and the equations can be easily identified for the pull-up and pull-down based on the above discussion. Therefore, total gate driver loss dissipated in the gate driver UCC21222  $P_{GD}$ , is:

$$P_{GD} = P_{GDQ} + P_{GDO} \quad (17)$$

which is equal to 127 mW in the design example.

### 9.2.2.7 Estimating Junction Temperature

The junction temperature of the UCC21222 can be estimated with:

$$T_J = T_C + \Psi_{JT} \times P_{GD}$$

where

- $T_J$  is the junction temperature.
- $T_C$  is the UCC21222 case-top temperature measured with a thermocouple or some other instrument.
- $\Psi_{JT}$  is the junction-to-top characterization parameter from the [Thermal Information](#) table. (18)

Using the junction-to-top characterization parameter ( $\Psi_{JT}$ ) instead of the junction-to-case thermal resistance ( $R_{\theta JC}$ ) can greatly improve the accuracy of the junction temperature estimation. The majority of the thermal energy of most ICs is released into the PCB through the package leads, whereas only a small percentage of the total energy is released through the top of the case (where thermocouple measurements are usually conducted).  $R_{\theta JC}$  can only be used effectively when most of the thermal energy is released through the case, such as with metal packages or when a heatsink is applied to an IC package. In all other cases, use of  $R_{\theta JC}$  will inaccurately

estimate the true junction temperature.  $\Psi_{JT}$  is experimentally derived by assuming that the amount of energy leaving through the top of the IC will be similar in both the testing environment and the application environment. As long as the recommended layout guidelines are observed, junction temperature estimates can be made accurately to within a few degrees Celsius. For more information, see the [Layout Guidelines](#) and [Semiconductor and IC Package Thermal Metrics application report](#).

### 9.2.2.8 Selecting VCCI, VDDA/B Capacitor

Bypass capacitors for VCCI, VDDA, and VDDB are essential for achieving reliable performance. It is recommended that one choose low ESR and low ESL surface-mount multi-layer ceramic capacitors (MLCC) with sufficient voltage ratings, temperature coefficients and capacitance tolerances. Importantly, DC bias on an MLCC will impact the actual capacitance value. For example, a 25-V, 1- $\mu$ F X7R capacitor is measured to be only 500 nF when a DC bias of 15 V<sub>DC</sub> is applied.

#### 9.2.2.8.1 Selecting a VCCI Capacitor

A bypass capacitor connected to VCCI supports the transient current needed for the primary logic and the total current consumption, which is only a few mA. Therefore, a 25-V MLCC with over 100 nF is recommended for this application. If the bias power supply output is a relatively long distance from the VCCI pin, a tantalum or electrolytic capacitor, with a value over 1  $\mu$ F, should be placed in parallel with the MLCC.

#### 9.2.2.8.2 Selecting a VDDA (Bootstrap) Capacitor

A VDDA capacitor, also referred to as a *bootstrap capacitor* in bootstrap power supply configurations, allows for gate drive current transients up to 6 A, and needs to maintain a stable gate drive voltage for the power transistor.

The total charge needed per switching cycle can be estimated with

$$Q_{\text{Total}} = Q_G + \frac{I_{\text{VDD}} @ 100\text{kHz (No Load)}}{f_{\text{SW}}} = 100\text{nC} + \frac{1.5\text{mA}}{100\text{kHz}} = 115\text{nC}$$

where

- $Q_G$ : Gate charge of the power transistor.
- $I_{\text{VDD}}$ : The channel self-current consumption with no load at 100kHz.
- 

(19)

Therefore, the absolute minimum  $C_{\text{Boot}}$  requirement is:

$$C_{\text{Boot}} = \frac{Q_{\text{Total}}}{\Delta V_{\text{VDDA}}} = \frac{115\text{nC}}{0.5\text{V}} = 230\text{nF}$$

where

- $\Delta V_{\text{VDDA}}$  is the voltage ripple at VDDA, which is 0.5 V in this example.

(20)

In practice, the value of  $C_{\text{Boot}}$  is greater than the calculated value. This allows for the capacitance shift caused by the DC bias voltage and for situations where the power stage would otherwise skip pulses due to load transients. Therefore, it is recommended to include a safety-related margin in the  $C_{\text{Boot}}$  value and place it as close to the VDD and VSS pins as possible. A 50-V 1- $\mu$ F capacitor is chosen in this example.

$$C_{\text{Boot}} = 1\mu\text{F}$$

(21)

To further lower the AC impedance for a wide frequency range, it is recommended to have bypass capacitor with a low capacitance value, in this example a 100 nF, in parallel with  $C_{\text{Boot}}$  to optimize the transient performance.

#### NOTE

Too large  $C_{\text{BOOT}}$  is not good.  $C_{\text{BOOT}}$  may not be charged within the first few cycles and  $V_{\text{BOOT}}$  could stay below UVLO. As a result, the high-side FET does not follow input signal command. Also during initial  $C_{\text{BOOT}}$  charging cycles, the bootstrap diode has highest reverse recovery current and losses.

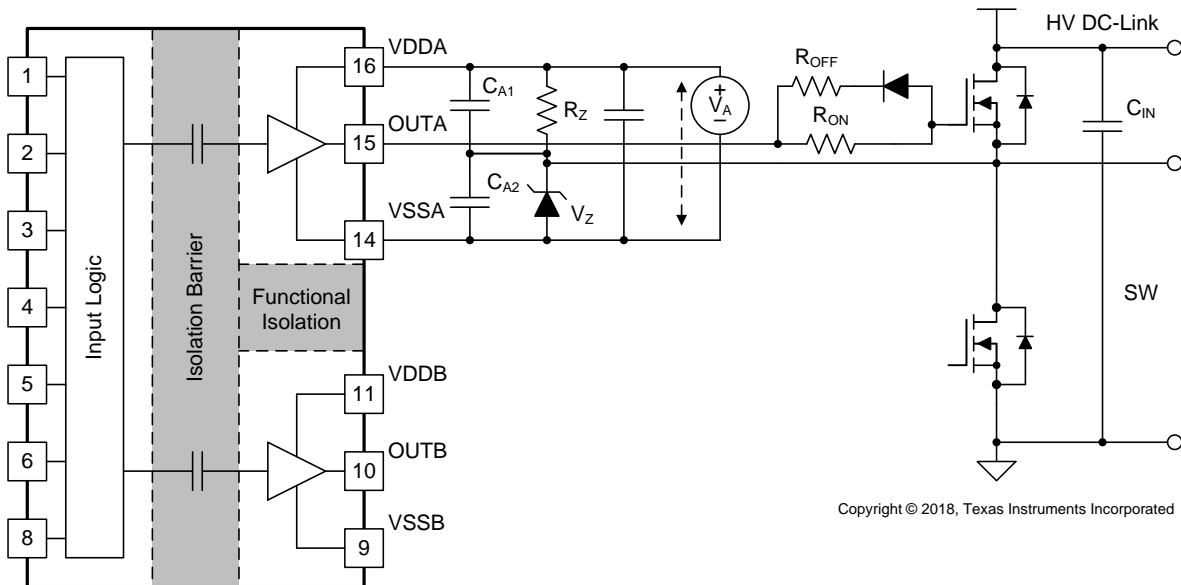
**9.2.2.8.3 Select a VDDB Capacitor**

Channel B has the same current requirements as Channel A, Therefore, a VDDB capacitor (Shown as  $C_{VDD}$  in Figure 38) is needed. In this example with a bootstrap configuration, the VDDB capacitor will also supply current for VDDA through the bootstrap diode. A 50-V, 10- $\mu$ F MLCC and a 50-V, 220-nF MLCC are chosen for  $C_{VDD}$ . If the bias power supply output is a relatively long distance from the VDDB pin, a tantalum or electrolytic capacitor with a value over 10  $\mu$ F, should be used in parallel with  $C_{VDD}$ .

**9.2.2.9 Application Circuits with Output Stage Negative Bias**

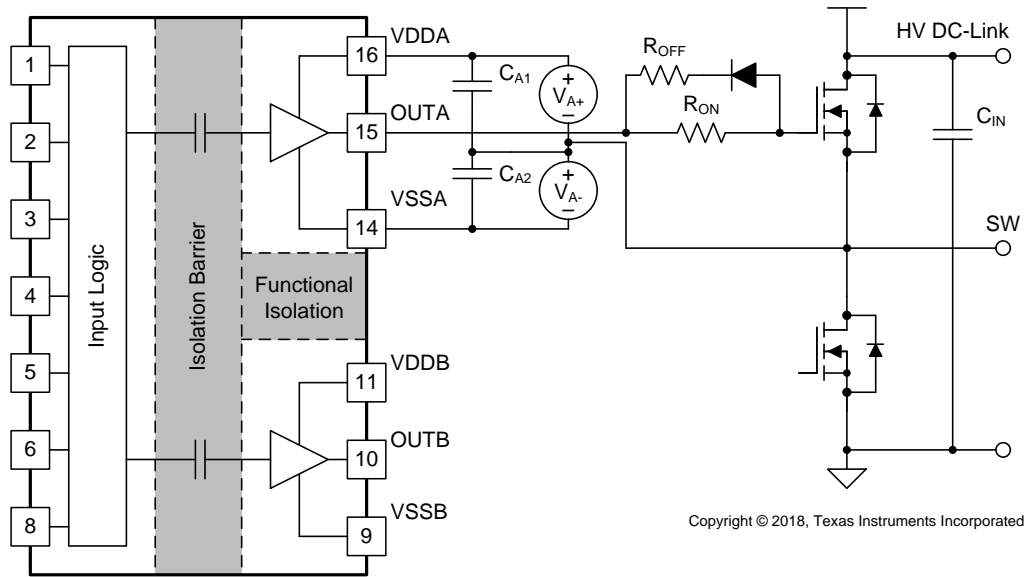
When parasitic inductances are introduced by non-ideal PCB layout and long package leads (e.g. TO-220 and TO-247 type packages), there could be ringing in the gate-source drive voltage of the power transistor during high di/dt and dv/dt switching. If the ringing is over the threshold voltage, there is the risk of unintended turn-on and even shoot-through. Applying a negative bias on the gate drive is a popular way to keep such ringing below the threshold. Below are a few examples of implementing negative gate drive bias.

Figure 39 shows the first example with negative bias turn-off on the channel-A driver using a Zener diode on the isolated power supply output stage. The negative bias is set by the Zener diode voltage. If the isolated power supply,  $V_A$ , is equal to 17 V, the turn-off voltage will be  $-5.1$  V and turn-on voltage will be  $17$  V  $-$   $5.1$  V  $\approx$  12 V. The channel-B driver circuit is the same as channel-A, therefore, this configuration needs two power supplies for a half-bridge configuration, and there will be steady state power consumption from  $R_Z$ .



**Figure 39. Negative Bias with Zener Diode on Iso-Bias Power Supply Output**

Figure 40 shows another example which uses two supplies (or single-input-double-output power supply). Power supply  $V_{A+}$  determines the positive drive output voltage and  $V_{A-}$  determines the negative turn-off voltage. The configuration for channel B is the same as channel A. This solution requires more power supplies than the first example, however, it provides more flexibility when setting the positive and negative rail voltages.

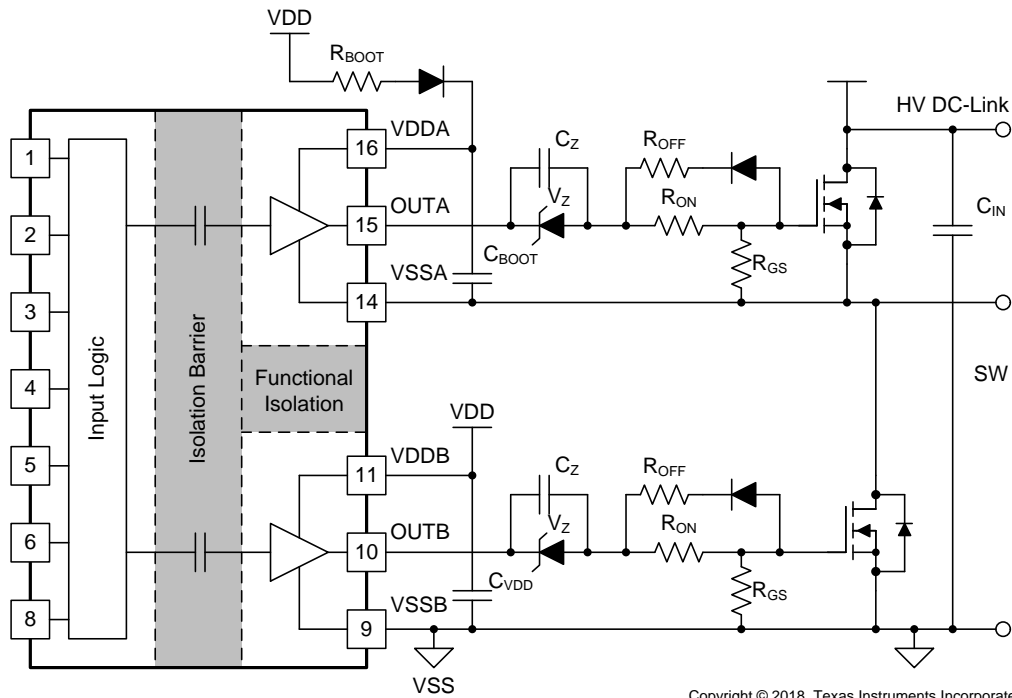


Copyright © 2018, Texas Instruments Incorporated

Figure 40. Negative Bias with Two Iso-Bias Power Supplies

The last example, shown in [Figure 41](#), is a single power supply configuration and generates negative bias through a Zener diode in the gate drive loop. The benefit of this solution is that it only uses one power supply and the bootstrap power supply can be used for the high side drive. This design requires the least cost and design effort among the three solutions. However, this solution has limitations:

1. The negative gate drive bias is not only determined by the Zener diode, but also by the duty cycle, which means the negative bias voltage will change when the duty cycle changes. Therefore, converters with a fixed duty cycle (~50%) such as variable frequency resonant converters or phase shift converters which favor this solution.
2. The high side VDDA-VSSA must maintain enough voltage to stay in the recommended power supply range, which means the low side switch must turn-on or have free-wheeling current on the body (or anti-parallel) diode for a certain period during each switching cycle to refresh the bootstrap capacitor. Therefore, a 100% duty cycle for the high side is not possible unless there is a dedicated power supply for the high side, like in the other two example circuits.



Copyright © 2018, Texas Instruments Incorporated

**Figure 41. Negative Bias with Single Power Supply and Zener Diode in Gate Drive Path**

### 9.2.3 Application Curves

Figure 42 and Figure 43 shows the bench test waveforms for the design example shown in Figure 38 under these conditions: VCC = 5.0 V, VDD = 12 V, f<sub>SW</sub> = 100 kHz, V<sub>DC-Link</sub> = 400 V.

**Channel 1 (Blue):** Gate-source signal on the high side power transistor.

**Channel 2 (Cyan):** Gate-source signal on the low side power transistor.

**Channel 3 (Pink):** INA pin signal.

**Channel 4 (Green):** INB pin signal.

In Figure 42, INA and INB are sent complimentary 3.3-V, 20%/80% duty-cycle signals. The gate drive signals on the power transistor have a 200-ns dead time with 400V high voltage on the DC-Link, shown in the measurement section of Figure 42. Note that with high voltage present, lower bandwidth differential probes are required, which limits the achievable accuracy of the measurement.

Figure 43 shows a zoomed-in version of the waveform of Figure 42, with measurements for propagation delay and dead time. Importantly, the output waveform is measured between the power transistors' gate and source pins, and is not measured directly from the driver OUTA and OUTB pins.

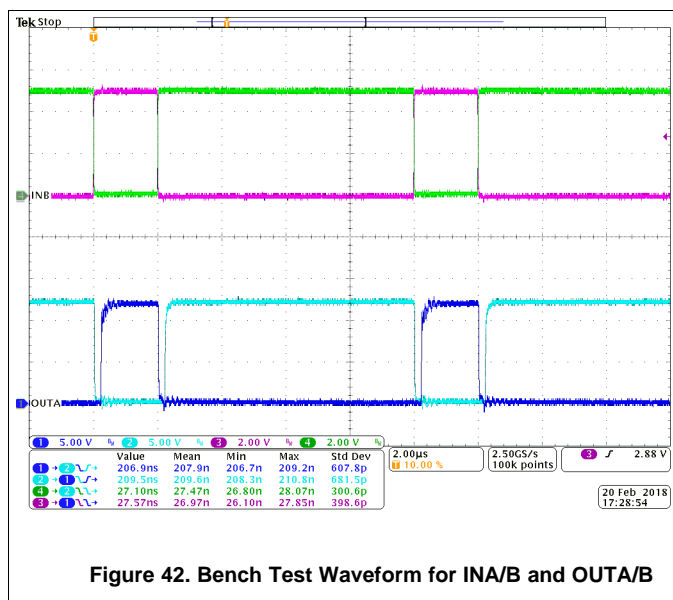


Figure 42. Bench Test Waveform for INA/B and OUTA/B

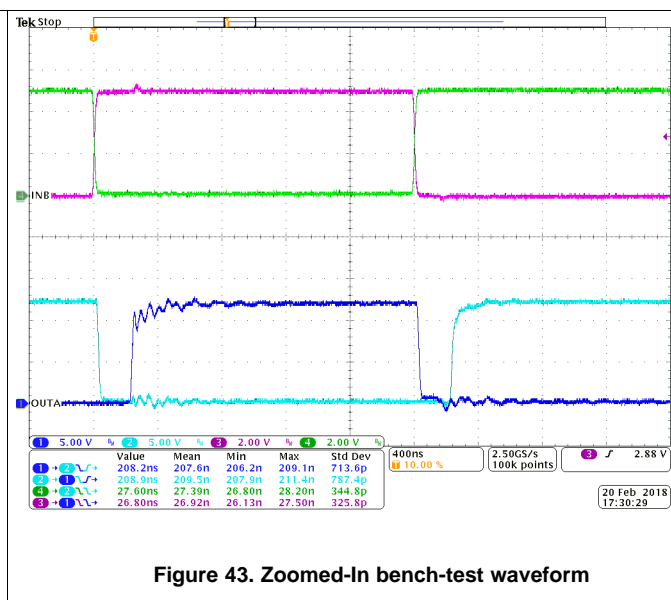


Figure 43. Zoomed-In bench-test waveform

## 10 Power Supply Recommendations

The recommended input supply voltage (VCCI) for the UCC21222 is between 3 V and 5.5 V. The output bias supply voltage (VDDA/VDDDB) ranges from 9.2 V to 18 V. The lower end of this bias supply range is governed by the internal under voltage lockout (UVLO) protection feature of each device. VDD and VCCI must not fall below their respective UVLO thresholds during normal operation. (For more information on UVLO see [VDD, VCCI, and Under Voltage Lock Out \(UVLO\)](#)). The upper end of the VDDA/VDDDB range depends on the maximum gate voltage of the power device being driven by the UCC21222. The recommended maximum VDDA/VDDDB is 18 V.

A local bypass capacitor should be placed between the VDD and VSS pins, to supply current when the output goes high into a capacitive load. This capacitor should be positioned as close to the device as possible to minimize parasitic impedance. A low ESR, ceramic surface mount capacitor is recommended. If the bypass capacitor impedance is too large, resistive and inductive parasitics could cause the supply voltage seen at the IC pins to dip below the UVLO threshold unexpectedly. To filter high frequency noise between VDD and VSS, it can be helpful to place a second capacitor with lower impedance at higher frequency. As an example, the primary bypass capacitor could be 1  $\mu$ F, with a secondary high frequency bypass capacitor of 100 pF.

Similarly, a bypass capacitor should also be placed between the VCCI and GND pins. Given the small amount of current drawn by the logic circuitry within the input side of the UCC21222, this bypass capacitor has a minimum recommended value of 100 nF.

## 11 Layout

### 11.1 Layout Guidelines

Consider these PCB layout guidelines for in order to achieve optimum performance for the UCC21222.

#### 11.1.1 Component Placement Considerations

- Low-ESR and low-ESL capacitors must be connected close to the device between the VCCI and GND pins and between the VDD and VSS pins to support high peak currents when turning on the external power transistor.
- To avoid large negative transients on the switch node VSSA (HS) pin in bridge configurations, the parasitic inductances between the source of the top transistor and the source of the bottom transistor must be minimized.
- To improve noise immunity when driving the DIS pin from a distant microcontroller, TI recommends adding a small bypass capacitor,  $\geq 1000$  pF, between the DIS pin and GND.
- If the dead time feature is used, TI recommends placing the programming resistor  $R_{DT}$  and capacitor close to the DT pin of the UCC21222 to prevent noise from unintentionally coupling to the internal dead time circuit. The capacitor should be  $\geq 2.2$  nF.

#### 11.1.2 Grounding Considerations

- It is essential to confine the high peak currents that charge and discharge the transistor gates to a minimal physical area. This will decrease the loop inductance and minimize noise on the gate terminals of the transistors. The gate driver must be placed as close as possible to the transistors.
- Pay attention to high current path that includes the bootstrap capacitor, bootstrap diode, local VSSB-referenced bypass capacitor, and the low-side transistor body/anti-parallel diode. The bootstrap capacitor is recharged on a cycle-by-cycle basis through the bootstrap diode by the VDD bypass capacitor. This recharging occurs in a short time interval and involves a high peak current. Minimizing this loop length and area on the circuit board is important for ensuring reliable operation.

#### 11.1.3 High-Voltage Considerations

- To ensure isolation performance between the primary and secondary side, avoid placing any PCB traces or copper below the driver device. A PCB cutout is recommended in order to prevent contamination that may compromise the isolation performance.
- For half-bridge or high-side/low-side configurations, maximize the clearance distance of the PCB layout between the high and low-side PCB traces.

#### 11.1.4 Thermal Considerations

- A large amount of power may be dissipated by the UCC21222 if the driving voltage is high, the load is heavy, or the switching frequency is high (refer to [Estimating Gate Driver Power Loss](#) for more details). Proper PCB layout can help dissipate heat from the device to the PCB and minimize junction to board thermal impedance ( $\theta_{JB}$ ).
- Increasing the PCB copper connecting to VDDA, VDDB, VSSA and VSSB pins is recommended, with priority on maximizing the connection to VSSA and VSSB (see [Figure 45](#) and [Figure 46](#)). However, high voltage PCB considerations mentioned above must be maintained.
- If there are multiple layers in the system, it is also recommended to connect the VDDA, VDDB, VSSA and VSSB pins to internal ground or power planes through multiple vias of adequate size. Ensure that no traces or copper from different high-voltage planes overlap.

## 11.2 Layout Example

Figure 44 shows a 2-layer PCB layout example with the signals and key components labeled.

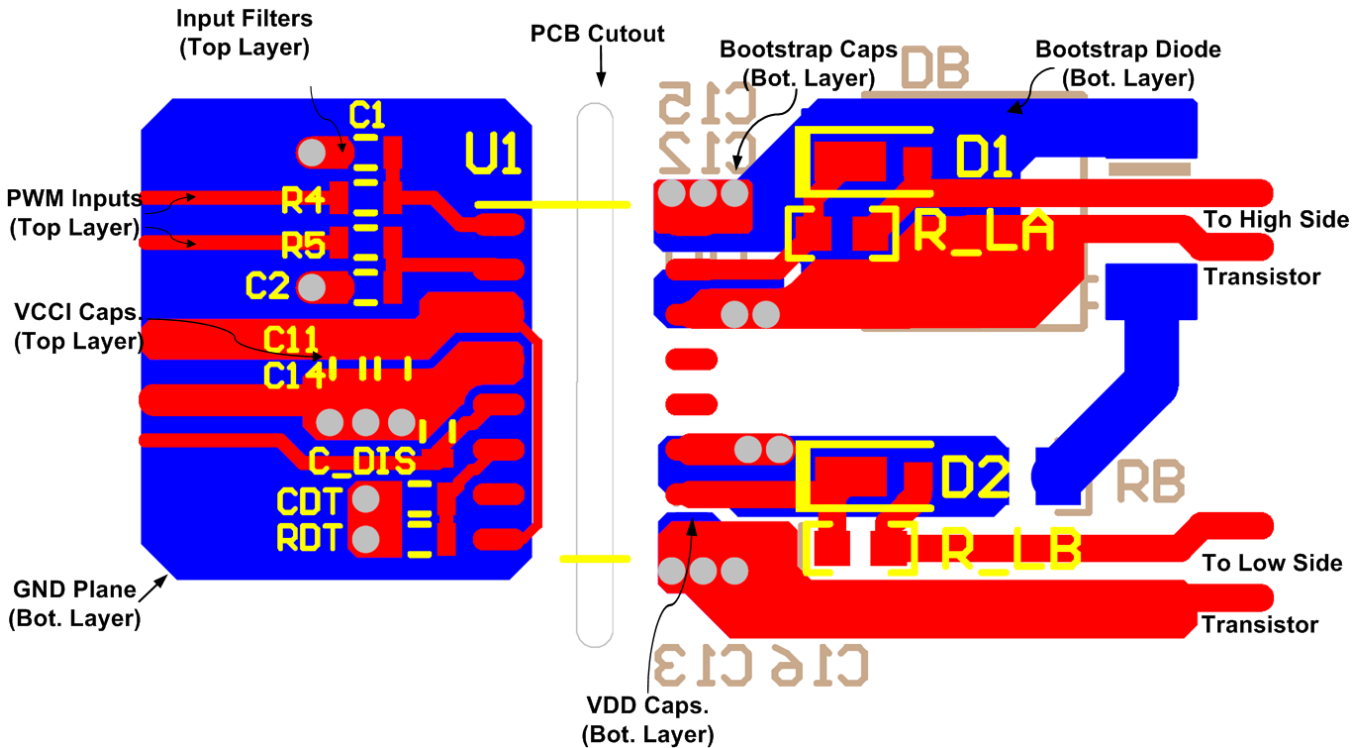


Figure 44. Layout Example

Figure 45 and Figure 46 shows top and bottom layer traces and copper.

### NOTE

There are no PCB traces or copper between the primary and secondary side, which ensures isolation performance.

PCB traces between the high-side and low-side gate drivers in the output stage are increased to maximize the creepage distance for high-voltage operation, which will also minimize cross-talk between the switching node VSSA (SW), where high  $dv/dt$  may exist, and the low-side gate drive due to the parasitic capacitance coupling.

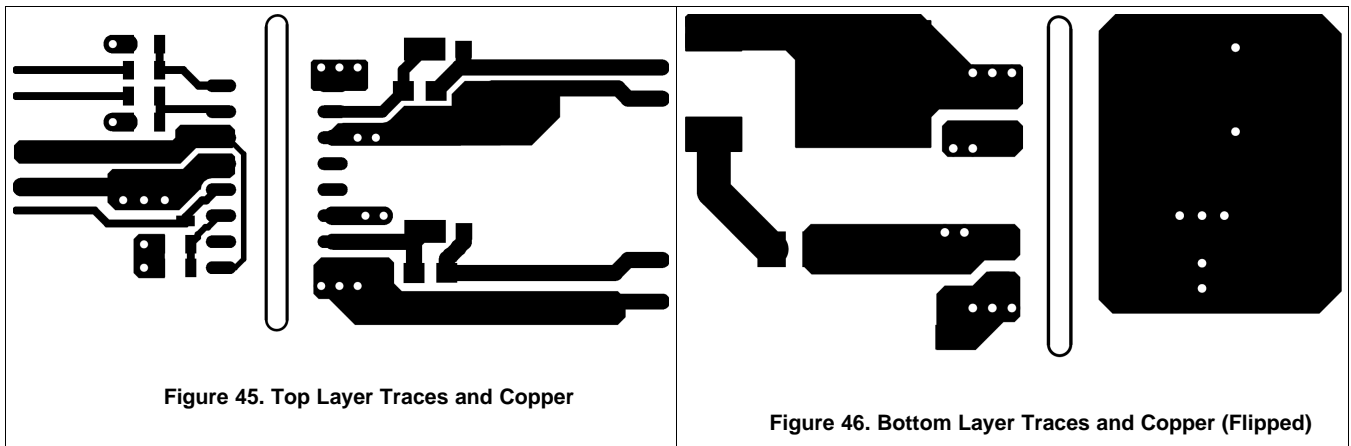


Figure 45. Top Layer Traces and Copper

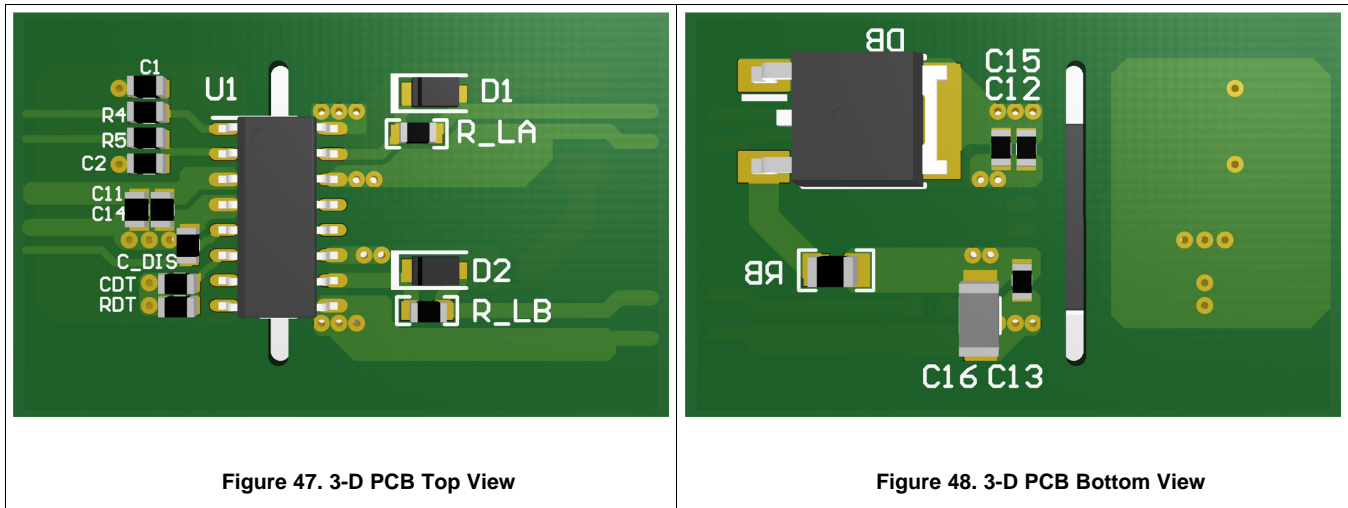
Figure 46. Bottom Layer Traces and Copper (Flipped)

**Layout Example (continued)**

Figure 47 and Figure 48 are 3-D layout pictures with top view and bottom views.

**NOTE**

The location of the PCB cutout between the primary side and secondary sides, which ensures isolation performance.



## 12 Device and Documentation Support

### 12.1 Device Support

#### 12.1.1 Development Support

##### 12.1.1.1 Custom Design With WEBENCH® Tools

Click [here](#) to create a custom design using the UCC21222 device with the WEBENCH® Power Designer.

1. Start by entering the input voltage ( $V_{IN}$ ), output voltage ( $V_{OUT}$ ), and output current ( $I_{OUT}$ ) requirements.
2. Optimize the design for key parameters such as efficiency, footprint, and cost using the optimizer dial.
3. Compare the generated design with other possible solutions from Texas Instruments.

The WEBENCH Power Designer provides a customized schematic along with a list of materials with real-time pricing and component availability.

In most cases, these actions are available:

- Run electrical simulations to see important waveforms and circuit performance
- Run thermal simulations to understand board thermal performance
- Export customized schematic and layout into popular CAD formats
- Print PDF reports for the design, and share the design with colleagues

Get more information about WEBENCH tools at [www.ti.com/WEBENCH](http://www.ti.com/WEBENCH).

### 12.2 Documentation Support

#### 12.2.1 Related Documentation

For related documentation see the following:

- [Isolation Glossary](#)

#### 12.3 Related Links

The table below lists quick access links. Categories include technical documents, support and community resources, tools and software, and quick access to sample or buy.

**Table 5. Related Links**

PARTS	PRODUCT FOLDER	SAMPLE & BUY	TECHNICAL DOCUMENTS	TOOLS & SOFTWARE	SUPPORT & COMMUNITY
UCC21222	<a href="#">Click here</a>	<a href="#">Click here</a>	<a href="#">Click here</a>	<a href="#">Click here</a>	<a href="#">Click here</a>

#### 12.4 Receiving Notification of Documentation Updates

To receive notification of documentation updates, navigate to the device product folder on ti.com. In the upper right corner, click on *Alert me* to register and receive a weekly digest of any product information that has changed. For change details, review the revision history included in any revised document.

#### 12.5 Community Resources

The following links connect to TI community resources. Linked contents are provided "AS IS" by the respective contributors. They do not constitute TI specifications and do not necessarily reflect TI's views; see TI's [Terms of Use](#).

**TI E2E™ Online Community** *TI's Engineer-to-Engineer (E2E) Community*. Created to foster collaboration among engineers. At e2e.ti.com, you can ask questions, share knowledge, explore ideas and help solve problems with fellow engineers.

**Design Support** *TI's Design Support* Quickly find helpful E2E forums along with design support tools and contact information for technical support.

#### 12.6 Trademarks

## 12.6 Trademarks (continued)

E2E is a trademark of Texas Instruments.  
WEBENCH is a registered trademark of Texas Instruments.

## 12.7 Electrostatic Discharge Caution



These devices have limited built-in ESD protection. The leads should be shorted together or the device placed in conductive foam during storage or handling to prevent electrostatic damage to the MOS gates.

## 12.8 Glossary

[SLYZ022](#) — *TI Glossary*.

This glossary lists and explains terms, acronyms, and definitions.

## 13 Mechanical, Packaging, and Orderable Information

The following pages include mechanical, packaging, and orderable information. This information is the most current data available for the designated devices. This data is subject to change without notice and revision of this document. For browser-based versions of this data sheet, refer to the left-hand navigation.

**PACKAGING INFORMATION**

Orderable Device	Status (1)	Package Type	Package Drawing	Pins	Package Qty	Eco Plan (2)	Lead/Ball Finish (6)	MSL Peak Temp (3)	Op Temp (°C)	Device Marking (4/5)	Samples
UCC21222D	ACTIVE	SOIC	D	16	40	Green (RoHS & no Sb/Br)	NIPDAU	Level-2-260C-1 YEAR	-40 to 125	21222	<a href="#">Samples</a>
UCC21222DR	ACTIVE	SOIC	D	16	2500	Green (RoHS & no Sb/Br)	NIPDAU	Level-2-260C-1 YEAR	-40 to 125	21222	<a href="#">Samples</a>

(1) The marketing status values are defined as follows:

**ACTIVE:** Product device recommended for new designs.

**LIFEBUY:** TI has announced that the device will be discontinued, and a lifetime-buy period is in effect.

**NRND:** Not recommended for new designs. Device is in production to support existing customers, but TI does not recommend using this part in a new design.

**PREVIEW:** Device has been announced but is not in production. Samples may or may not be available.

**OBSOLETE:** TI has discontinued the production of the device.

(2) **RoHS:** TI defines "RoHS" to mean semiconductor products that are compliant with the current EU RoHS requirements for all 10 RoHS substances, including the requirement that RoHS substance do not exceed 0.1% by weight in homogeneous materials. Where designed to be soldered at high temperatures, "RoHS" products are suitable for use in specified lead-free processes. TI may reference these types of products as "Pb-Free".

**RoHS Exempt:** TI defines "RoHS Exempt" to mean products that contain lead but are compliant with EU RoHS pursuant to a specific EU RoHS exemption.

**Green:** TI defines "Green" to mean the content of Chlorine (Cl) and Bromine (Br) based flame retardants meet JS709B low halogen requirements of <=1000ppm threshold. Antimony trioxide based flame retardants must also meet the <=1000ppm threshold requirement.

(3) MSL, Peak Temp. - The Moisture Sensitivity Level rating according to the JEDEC industry standard classifications, and peak solder temperature.

(4) There may be additional marking, which relates to the logo, the lot trace code information, or the environmental category on the device.

(5) Multiple Device Markings will be inside parentheses. Only one Device Marking contained in parentheses and separated by a "~" will appear on a device. If a line is indented then it is a continuation of the previous line and the two combined represent the entire Device Marking for that device.

(6) Lead/Ball Finish - Orderable Devices may have multiple material finish options. Finish options are separated by a vertical ruled line. Lead/Ball Finish values may wrap to two lines if the finish value exceeds the maximum column width.

**Important Information and Disclaimer:**The information provided on this page represents TI's knowledge and belief as of the date that it is provided. TI bases its knowledge and belief on information provided by third parties, and makes no representation or warranty as to the accuracy of such information. Efforts are underway to better integrate information from third parties. TI has taken and continues to take reasonable steps to provide representative and accurate information but may not have conducted destructive testing or chemical analysis on incoming materials and chemicals. TI and TI suppliers consider certain information to be proprietary, and thus CAS numbers and other limited information may not be available for release.

In no event shall TI's liability arising out of such information exceed the total purchase price of the TI part(s) at issue in this document sold by TI to Customer on an annual basis.

**OTHER QUALIFIED VERSIONS OF UCC21222 :**

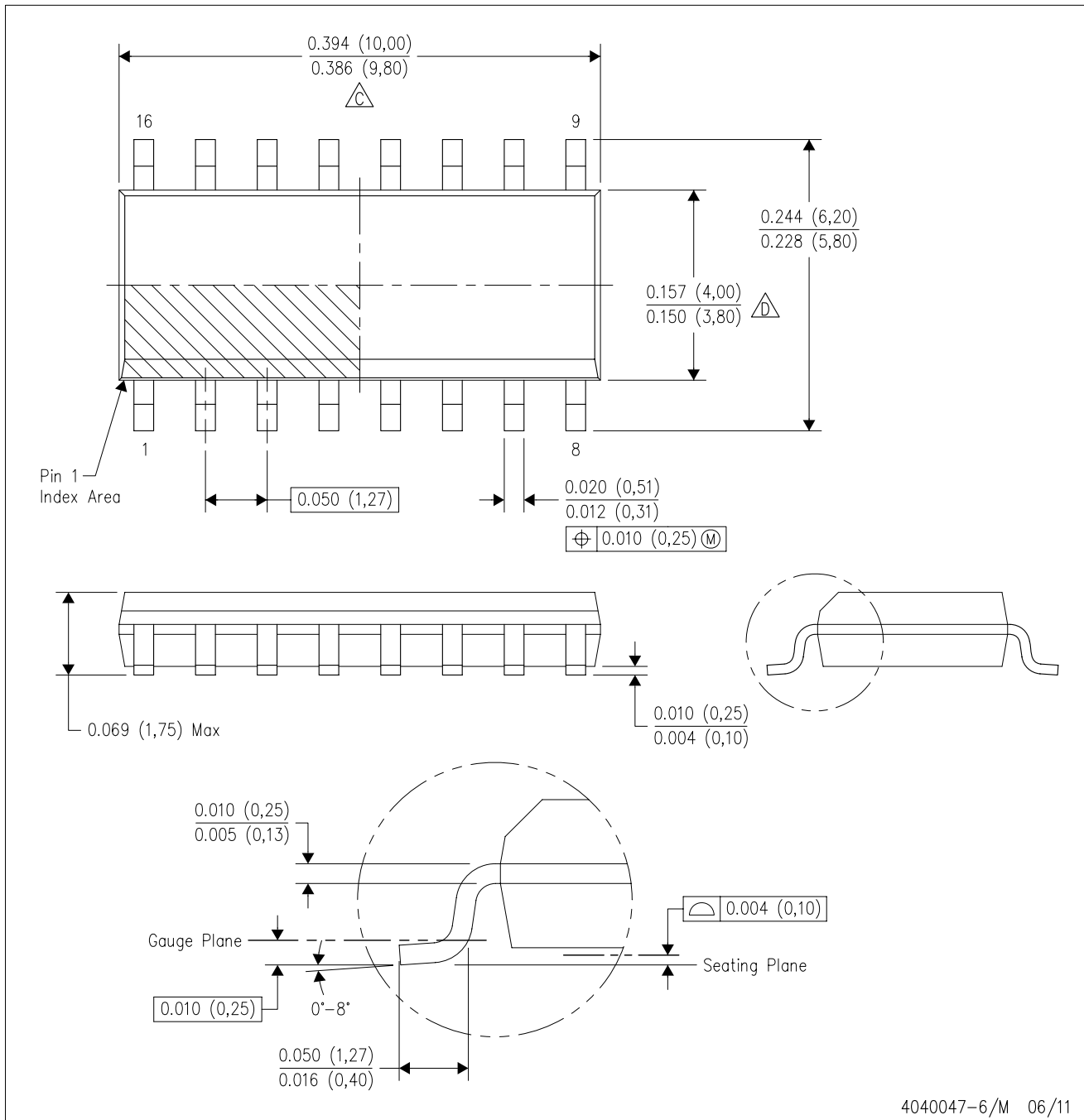
- Automotive: [UCC21222-Q1](#)

## NOTE: Qualified Version Definitions:

- Automotive - Q100 devices qualified for high-reliability automotive applications targeting zero defects

D (R-PDSO-G16)

PLASTIC SMALL OUTLINE



- NOTES:
- A. All linear dimensions are in inches (millimeters).
  - B. This drawing is subject to change without notice.
  - C. Body length does not include mold flash, protrusions, or gate burrs. Mold flash, protrusions, or gate burrs shall not exceed 0.006 (0,15) each side.
  - D. Body width does not include interlead flash. Interlead flash shall not exceed 0.017 (0,43) each side.
  - E. Reference JEDEC MS-012 variation AC.

## IMPORTANT NOTICE AND DISCLAIMER

TI PROVIDES TECHNICAL AND RELIABILITY DATA (INCLUDING DATASHEETS), DESIGN RESOURCES (INCLUDING REFERENCE DESIGNS), APPLICATION OR OTHER DESIGN ADVICE, WEB TOOLS, SAFETY INFORMATION, AND OTHER RESOURCES "AS IS" AND WITH ALL FAULTS, AND DISCLAIMS ALL WARRANTIES, EXPRESS AND IMPLIED, INCLUDING WITHOUT LIMITATION ANY IMPLIED WARRANTIES OF MERCHANTABILITY, FITNESS FOR A PARTICULAR PURPOSE OR NON-INFRINGEMENT OF THIRD PARTY INTELLECTUAL PROPERTY RIGHTS.

These resources are intended for skilled developers designing with TI products. You are solely responsible for (1) selecting the appropriate TI products for your application, (2) designing, validating and testing your application, and (3) ensuring your application meets applicable standards, and any other safety, security, or other requirements. These resources are subject to change without notice. TI grants you permission to use these resources only for development of an application that uses the TI products described in the resource. Other reproduction and display of these resources is prohibited. No license is granted to any other TI intellectual property right or to any third party intellectual property right. TI disclaims responsibility for, and you will fully indemnify TI and its representatives against, any claims, damages, costs, losses, and liabilities arising out of your use of these resources.

TI's products are provided subject to TI's Terms of Sale ([www.ti.com/legal/termsofsale.html](http://www.ti.com/legal/termsofsale.html)) or other applicable terms available either on [ti.com](http://ti.com) or provided in conjunction with such TI products. TI's provision of these resources does not expand or otherwise alter TI's applicable warranties or warranty disclaimers for TI products.

Mailing Address: Texas Instruments, Post Office Box 655303, Dallas, Texas 75265  
Copyright © 2020, Texas Instruments Incorporated