

TPL7407L 40-V 7-Channel Low Side Driver

1 Features

- 600-mA Rated Drain Current (Per Channel)
- CMOS Pin-to-Pin Improvement of 7-channel Darlington Array (e.g. ULN2003A)
- Power Efficient (Very low V_{OL})
 - Less Than 4 Times Lower V_{OL} at 100 mA Than Darlington Array
- Very Low Output Leakage < 10 nA Per Channel
- Extended Ambient Temperature Range: $T_A = -40^{\circ}\text{C}$ to 125°C
- High-Voltage Outputs 40 V
- Compatible with 1.8-V to 5.0-V Micro-controllers and Logic Interface
- Internal Free-wheeling Diodes for Inductive Kick-back Protection
- Input Pull-down Resistors Allows Tri-stating the Input Driver
- Input RC-Snubber to Eliminate Spurious Operation in Noisy Environment
- Inductive Load Driver Applications
- ESD Protection Exceeds JESD 22
 - 2-kV HBM, 500-V CDM
- Available in 16-pin SOIC and TSSOP Packages

2 Applications

- Inductive Loads
 - Relays
 - Unipolar Stepper & Brushed DC Motors
 - Solenoids & Valves
- LEDs
- Logic Level Shifting
- Gate & IGBT Drive

3 Description

The TPL7407L is a high-voltage, high-current NMOS transistor array. This device consists of seven NMOS transistors that feature high-voltage outputs with common-cathode clamp diodes for switching inductive loads. The maximum drain-current rating of a single NMOS channel is 600 mA. New regulation and drive circuitry added to give maximum drive strength across all GPIO ranges (1.8 V – 5.0 V). The transistors can be paralleled for higher current capability.

The TPL7407L's key benefit is its improved power efficiency and lower leakage than a Bipolar Darlington Implementation. With the lower V_{OL} the user is dissipating less than half the power than traditional relay drivers with currents less than 250 mA per channel.

Device Information⁽¹⁾

PART NUMBER	PACKAGE (PINS)	BODY SIZE (NOM)
TPL7407LD	SOIC (16)	9.90 mm x 3.91 mm
TPL7407LPW	TSSOP (16)	5.00 mm x 4.40 mm

(1) For all available packages, see the orderable addendum at the end of the datasheet.

Simple Application Schematic

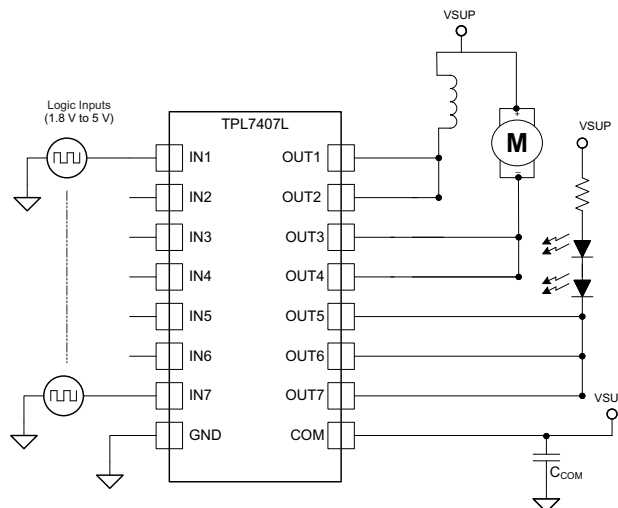

Table of Contents

1 Features	1	7.3 Feature Description	7
2 Applications	1	7.4 Device Functional Modes	7
3 Description	1	8 Application and Implementation	8
4 Revision History	2	8.1 Application Information	8
5 Pin Configuration and Functions	3	8.2 Typical Application	8
6 Specifications	3	9 Power Supply Recommendations	13
6.1 Absolute Maximum Ratings	3	10 Layout	13
6.2 ESD Ratings	4	10.1 Layout Guidelines	13
6.3 Recommended Operating Conditions	4	10.2 Layout Example	13
6.4 Thermal Information	4	10.3 Thermal Considerations	14
6.5 Electrical Characteristics	4	11 Device and Documentation Support	15
6.6 Switching Characteristics	5	11.1 Community Resources	15
6.7 Typical Characteristics	5	11.2 Trademarks	15
6.8 Thermal Characteristics	6	11.3 Electrostatic Discharge Caution	15
7 Detailed Description	7	11.4 Glossary	15
7.1 Overview	7	12 Mechanical, Packaging, and Orderable Information	15
7.2 Functional Block Diagram	7		

4 Revision History

NOTE: Page numbers for previous revisions may differ from page numbers in the current version.

Changes from Revision C (September 2015) to Revision D	Page
• Added note about driving inductive loads in Inductive Load Driver section.	8
• Changed Inductive Load Drive Schematic to reflect note about driving inductive loads.	8

Changes from Revision B (September 2014) to Revision C	Page
• Changed schematic to correct Zener diode connection	11

Changes from Revision A (August 2014) to Revision B	Page
• Added Handling Rating table, Feature Description section, Device Functional Modes, Application and Implementation section, Power Supply Recommendations section, Layout section, Device and Documentation Support section, and Mechanical, Packaging, and Orderable Information section.	1

Changes from Original (January 2014) to Revision A	Page
• Initial release of full version.	1

5 Pin Configuration and Functions

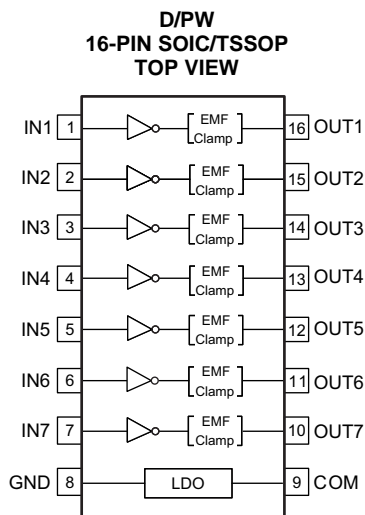

Pin Functions

PIN		I/O	DESCRIPTION
NAME	NO.		
COM	9	—	Supply pin that should be tied to 8.5 V or higher for proper operation (see Power Supply Recommendations for further instruction)
GND	8	—	Ground pin
IN(X)	1, 2, 3, 4, 5, 6, 7	I	GPIO inputs that will drive the outputs "low" (or sink current) when driven "high"
OUT(X)	16, 15, 14, 13, 12, 11, 10	O	Driver output that sinks currents after input is driven "high"

6 Specifications

6.1 Absolute Maximum Ratings

at 25°C free-air temperature (unless otherwise noted) ⁽¹⁾

		MIN	MAX	UNIT
V_{OUT}	Pins OUT1-OUT7 to GND voltage	-0.3	42	V
V_{OK}	Output Clamp diode reverse voltage ⁽²⁾	-0.3	42	V
V_{COM}	COM pin voltage ⁽²⁾	-0.3	42	V
V_{IN}	Pins IN1-IN7 to GND voltage ⁽²⁾	-0.3	30	V
I_{DS}	Continuous drain current per channel ^{(3) (4)}		600	mA
I_{OK}	Output clamp current		500	mA
I_{GND}	Total continuous GND-pin current		-2	A
T_A	Operating free-air temperature range	-40	125	°C
T_J	Operating virtual junction temperature	-40	150	°C
T_{stg}	Storage temperature range	-65	150	°C

- (1) Stresses beyond those listed under "absolute maximum ratings" may cause permanent damage to the device. These are stress ratings only, and functional operation of the device at these or any other conditions beyond those indicated under "recommended operating conditions" is not implied. Exposure to absolute-maximum-rated conditions for extended periods may affect device reliability.
- (2) All voltage values are with respect to the GND/substrate pin, unless otherwise noted.
- (3) Maximum power dissipation is a function of $T_J(\text{max})$, θ_{JA} , and T_A . The maximum allowable power dissipation at any allowable ambient temperature is $P_D = (T_J(\text{max}) - T_A)/\theta_{JA}$. Operating at the absolute maximum T_J of 150°C can affect reliability.
- (4) The package thermal impedance is calculated in accordance with JESD 51-7.

6.2 ESD Ratings

		VALUE	UNIT
$V_{(ESD)}$ Electrostatic discharge	Human-body model (HBM), per ANSI/ESDA/JEDEC JS-001 ⁽¹⁾	±2000	V
	Charged-device model (CDM), per JEDEC specification JESD22-C101 ⁽²⁾	±500	

- (1) JEDEC document JEP155 states that 500-V HBM allows safe manufacturing with a standard ESD control process. Manufacturing with less than 500-V HBM is possible with the necessary precautions.
- (2) JEDEC document JEP157 states that 250-V CDM allows safe manufacturing with a standard ESD control process. Manufacturing with less than 250-V CDM is possible with the necessary precautions.

6.3 Recommended Operating Conditions

Over operating temperature range

		MIN	MAX	UNIT
V_{OUT}	OUT1 – OUT7 pin voltage for recommended operation	0	40	V
V_{COM}	COM pin voltage range for full output drive	8.5	40	V
V_{IL}	IN1- IN7 input low voltage ("Off" high impedance output)		0.9	V
V_{IH}	IN1- IN7 input high voltage ("Full Drive" low impedance output)	1.5		V
T_J	Operating virtual junction temperature	–40	125	°C
I_{DS}	Continuous drain current	0	500	mA

6.4 Thermal Information

THERMAL METRIC ⁽¹⁾		TPL7407L		UNIT
		SOIC (D)	TSSOP (PW)	
		16 PINS	16 PINS	
θ_{JA}	Junction-to-ambient thermal resistance	91.9	115.2	°C/W
θ_{JcTop}	Junction-to-case (top) thermal resistance	50.1	49.5	°C/W
θ_{JB}	Junction-to-board thermal resistance	49.4	60.8	°C/W
Ψ_{JT}	Junction-to-top characterization parameter	18.6	8.5	°C/W
Ψ_{JB}	Junction-to-board characterization parameter	49.1	60.2	°C/W

- (1) For more information about traditional and new thermal metrics, see the *Semiconductor and IC Package Thermal Metrics* application report ([SPRA953](#)).

6.5 Electrical Characteristics

$T_J = -40^\circ\text{C}$ to 125°C ; Typical Values at $T_A = T_J = 25^\circ\text{C}$

PARAMETER		TEST CONDITIONS		MIN	TYP	MAX	UNIT
V_{OL} (V_{DS})	OUT1- OUT7 low-level output voltage	$V_{IN} \geq 1.5\text{ V}$	$I_D = 100\text{ mA}$		200	320	mV
			$I_D = 200\text{ mA}$		420	650	
$I_{OUT(OFF)}$ (I_{DS_OFF})	OUT1- OUT7 OFF-state leakage current	$V_{OUT} = 24\text{ V},$	$V_{IN} \leq 1.0\text{ V}$		10	500	nA
V_F	Clamp forward voltage	$I_F = 200\text{ mA}$				1.4	V
$I_{IN(off)}$	IN1- IN7 Off-state input current	$V_{INX} = 0\text{ V}$	$V_{OUT} = 40\text{ V}$			500	nA
$I_{IN(ON)}$	IN1- IN7 ON state input current	$V_{INX} = 1.5\text{ V} - 5.0\text{ V}$				10	μA
I_{COM}	Static current flowing through COM pin	$V_{COM} = 8.5\text{ V} - 40\text{ V}$			15	25	μA

6.6 Switching Characteristics

 Typical Values at $T_A = T_J = 25^\circ\text{C}$

PARAMETER	TEST CONDITIONS	MIN	TYP	MAX	UNIT
t_{PLH} Propagation delay time, low- to high-level output	$V_{INX} \geq 1.65\text{ V}$, $V_{pull-up} = 24\text{ V}$, $R_{pull-up} = 48\ \Omega$		350		ns
t_{PHL} Propagation delay time, high- to low-level output	$V_{INX} \geq 1.65\text{ V}$, $V_{pull-up} = 24\text{ V}$, $R_{pull-up} = 48\ \Omega$		350		ns
C_i Input capacitance	$V_i = 0$, $f = 100\text{ kHz}$		5		pF

6.7 Typical Characteristics

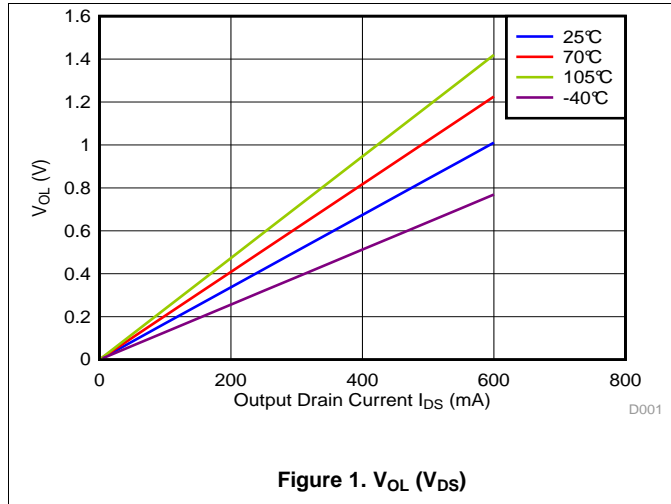
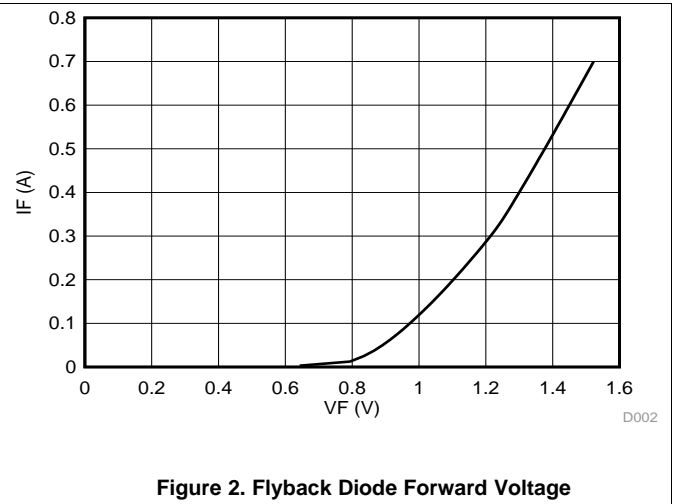
Figure 1. V_{OL} (V_{DS})

Figure 2. Flyback Diode Forward Voltage

6.8 Thermal Characteristics

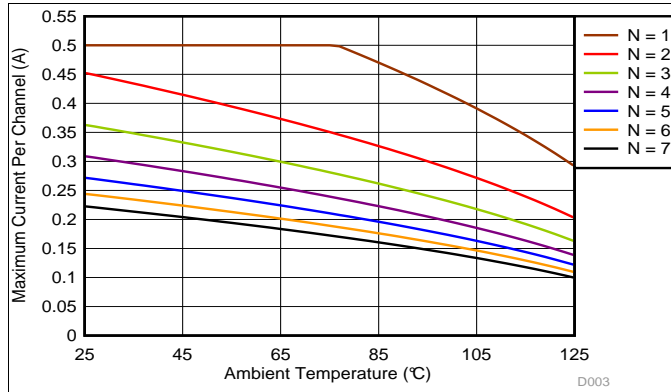

Figure 3. Maximum Output Current vs. Temperature (SOIC)

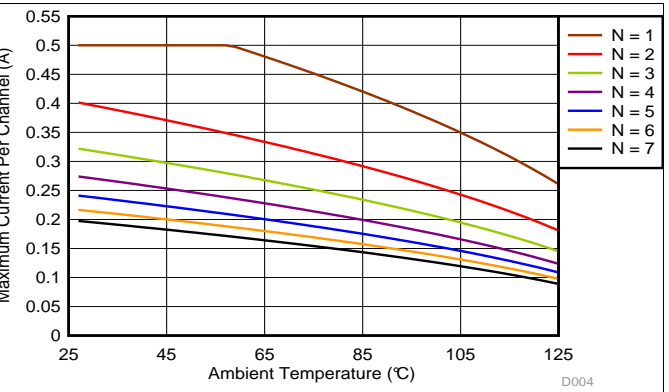

Figure 4. Maximum Output Current vs. Temperature (TSSOP)

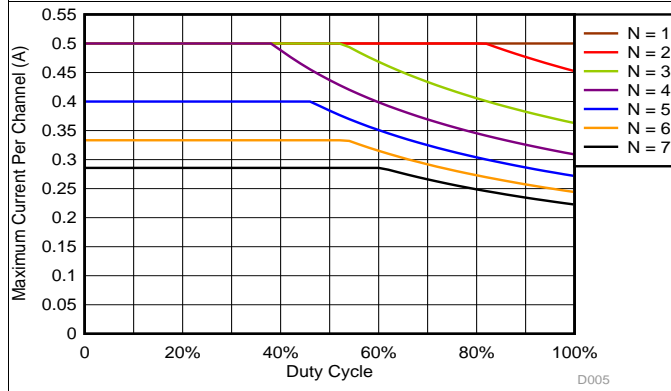

Figure 5. D Package Maximum Collector Current vs. Duty Cycle at 25°C

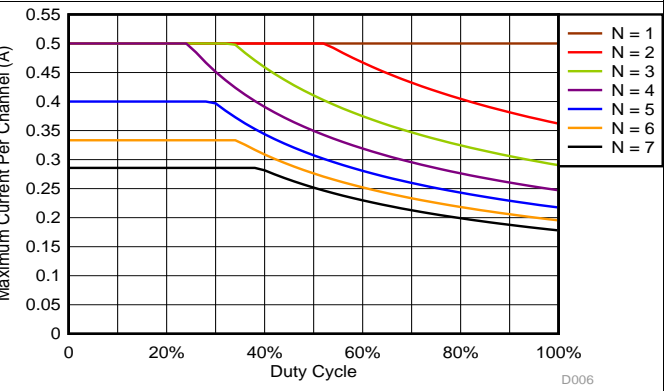

Figure 6. D Package Maximum Collector Current vs. Duty Cycle at 70°C

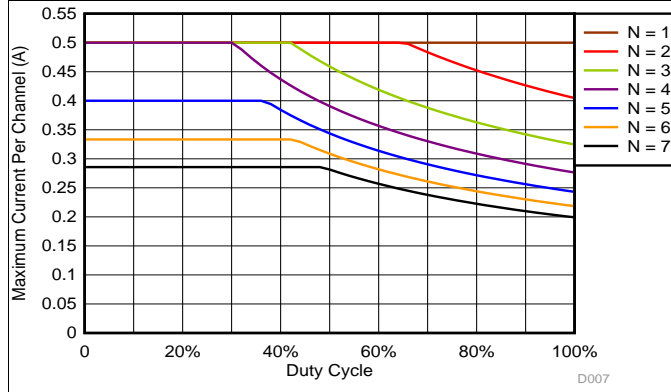

Figure 7. PW Package Maximum Collector Current vs. Duty Cycle at 25°C

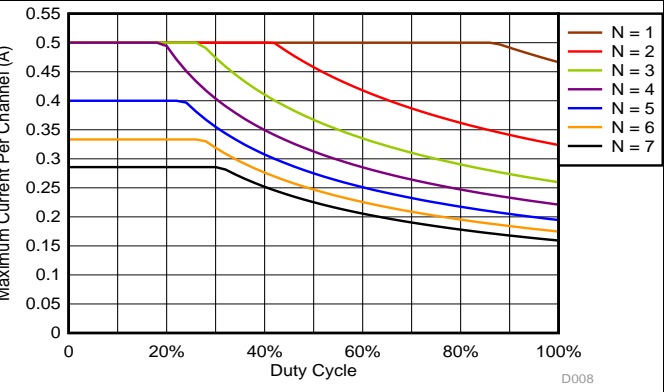

Figure 8. PW Package Maximum Collector Current vs. Duty Cycle at 70°C

7 Detailed Description

7.1 Overview

This device has proven ubiquity and versatility across a wide range of applications. This is due to its integration of 7 low side NMOS transistors that are capable of sinking up to 600mA and wide GPIO range capability.

The TPL7407L comprises seven high voltage, high current NMOS transistors tied to a common ground driven by internal level shifting and gate drive circuitry. The TPL7407L offers solutions to many interface needs, including solenoids, relays, lamps, small motors, and LEDs. Applications requiring sink currents beyond the capability of a single output may be accommodated by paralleling the outputs.

The TPL7407L also enables pin to pin replacement with legacy 7 channel darlington pair implementations

This device can operate over a wide temperature range (–40°C to 125°C).

7.2 Functional Block Diagram

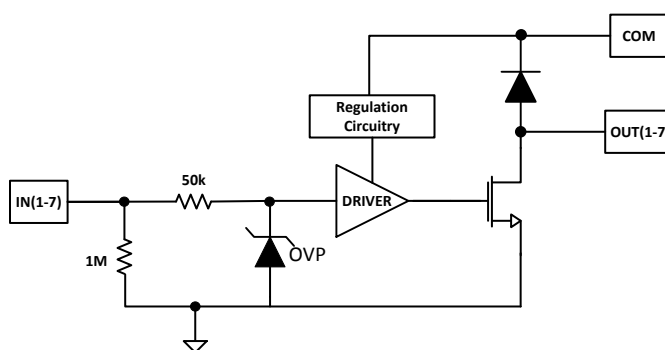

7.3 Feature Description

Each channel of TPL7407L consists of high power low side NMOS transistors driven by level shifting and gate driving circuitry. The gate drivers allow for high output current drive with a very low input voltage, essentially equating to operability with low GPIO voltages.

In order to enable floating inputs a 1MΩ pull-down resistor exists on each channel. Another 50-kΩ resistor exists between the input and gate driving circuitry. This exists to limit the input current whenever there is an over voltage and the internal Zener clamps. It also interacts with the inherent capacitance of the gate driving circuitry to behave as an RC snubber to help prevent spurious switching in noisy environment.

In order to power the gate driving circuitry an LDO exists. See [Power Supply Recommendations](#) for further detail on this circuitry.

The diodes connected between the output and COM pin is used to suppress kick-back voltage from an inductive load that is excited when the NMOS drivers are turned off (stop sinking) and the stored energy in the coils causes a reverse current to flow into the coil supply.

7.4 Device Functional Modes

7.4.1 Inductive Load Drive

When the COM pin is tied to the coil supply voltage, TPL7407L is able to drive inductive loads and suppress the kick-back voltage via the internal free wheeling diodes.

7.4.2 Resistive Load Drive

When driving a resistive load, a pull-up resistor is needed in order for TPL7407L to sink current and for there to be a logic high level. The COM pin should be supplied $\geq 8.5V$ for full functionality.

8 Application and Implementation

NOTE

Information in the following applications sections is not part of the TI component specification, and TI does not warrant its accuracy or completeness. TI's customers are responsible for determining suitability of components for their purposes. Customers should validate and test their design implementation to confirm system functionality.

8.1 Application Information

TPL7407L will typically be used to drive a high voltage and/or current peripheral from an MCU or logic device that cannot tolerate these conditions. The following design is a common application of TPL7407L, driving inductive loads. This includes motors, solenoids & relays. Each load type can be modeled by what's seen in [Figure 9](#).

8.2 Typical Application

8.2.1 Inductive Load Driver

Please note that inductive loads, such as stepper motors or relays, can generate negative transients on the OUTx pins of the device. Typically this occurs when the output channel FET turns ON, pulling the OUTx node to ground. This can cause the OUTx node to go below the voltage rating listed in the [Absolute Maximum Ratings](#) table, which in effect causes excessive ground current leakage. This effect is only seen on the OUT7 pin, and prolonged usage in this condition can cause permanent damage to the device.

If the application has an inductive load connected to OUT7, it is recommended to use an external Schottky diode to protect the OUT7 pin from negative transients larger than those listed in the [Absolute Maximum Ratings](#) table, such as in [Figure 9](#) below.

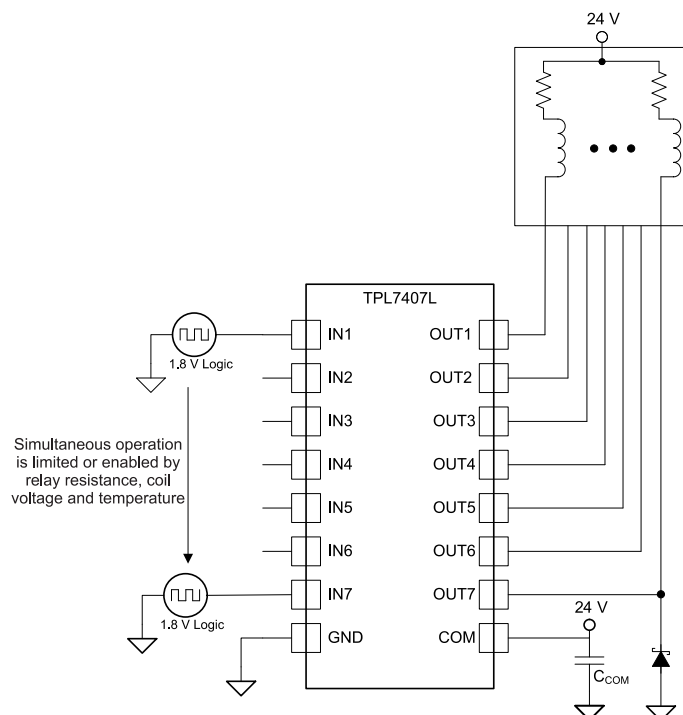

Figure 9. Inductive Load Driver Schematic

Typical Application (continued)

8.2.1.1 Design Requirements

For this design example, use the parameters listed in [Table 1](#) as the input parameters.

Table 1. Design Parameters

DESIGN PARAMETER	EXAMPLE VALUE
GPIO Voltage	1.8 V, 3.3 V or 5.0 V
Coil Supply Voltage	8.5 V to 40 V
Number of Channels	7
Output Current (R_{COIL})	20 mA to 300 mA per channel
C_{COM}	0.1 μ F
Duty Cycle	100%

8.2.1.2 Detailed Design Procedure

When using TPL7407L in a coil driving application, determine the following:

- Input Voltage Range
- Temperature Range
- Output & Drive Current
- Power Dissipation

8.2.1.2.1 TTL and other Logic Inputs

TPL7407L input interface is specified for standard 1.8 V through 5 V CMOS logic interface and can tolerate up to 30 V. At any input voltage the output drivers will be driven at it's maximum when V_{com} is greater than or equal to 8.5 V.

8.2.1.2.2 Input RC Snubber

TPL7407L features an input RC snubber that helps prevent spurious switching in noisy environments. Connect an external 1 k Ω to 5 k Ω resistor in series with the input to further enhance TPL7407L's noise tolerance.

8.2.1.2.3 High-impedance Input Drivers

TPL7407L features a 1-M Ω input pull-down resistor. The presence of this resistor allows the input drivers to be tri-stated. When a high-impedance driver is connected to a channel input the TPL7407L detects the channel input as a low level input and remains in the OFF position. The input RC snubber helps improve noise tolerance when input drivers are in the high-impedance state.

8.2.1.2.4 Drive Current

The coil current is determined by the coil voltage (V_{SUP}), coil resistance & output low voltage (V_{OL}).

$$I_{COIL} = (V_{SUP} - V_{OL}) / R_{COIL} \quad (1)$$

8.2.1.2.5 Output Low Voltage

The output low voltage (V_{OL}) is drain to source (V_{DS}) voltage of the output NMOS transistors when the input is driven high and it is sinking current and can be determined by [Specifications](#) or [Figure 1](#).

8.2.1.3 Application Curves

The following curve was generated with TPL7407L driving an OMRON G5NB relay -- $V_{in} = 5.0$ V; $V_{sup} = 24$ V & $R_{COIL} = 2.8$ k Ω

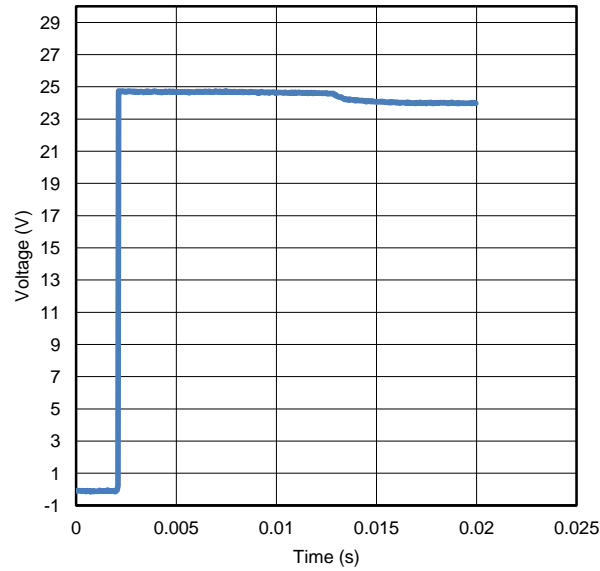

Figure 10. Output Response With De-activation of Coil (Turn Off)

8.2.2 Unipolar Stepper Motor Driver

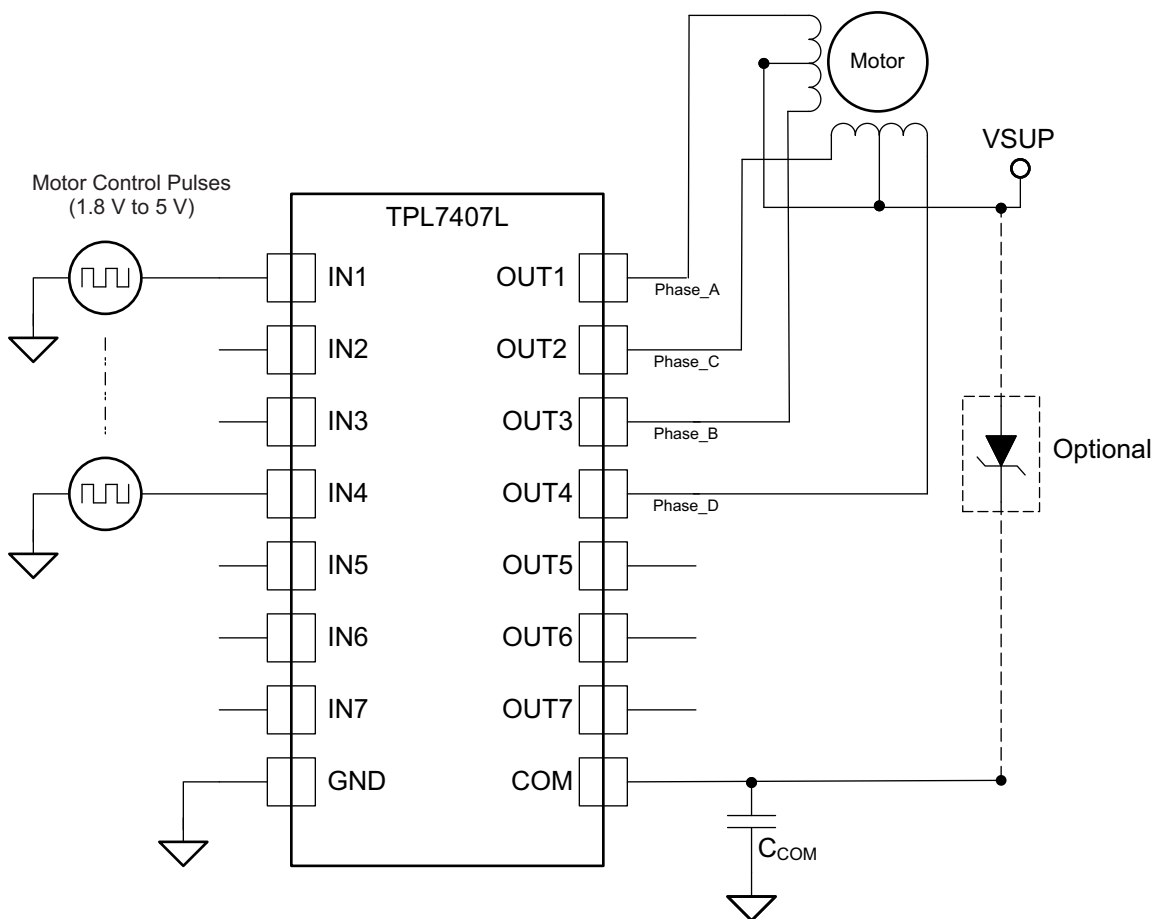

Figure 11. Stepper Motor Driver Schematic

8.2.2.1 Design Requirements

Figure 11 shows an implementation of TPL7407L for driving a unipolar stepper motor. The unconnected input channels can be used for other functions. When an input pin is left open the internal 1 MΩ pull down resistor pulls the respective input pin to GND potential. For higher noise immunity use an external short across an unconnected input and GND pins. The COM pin must be tied to the supply of whichever inductive load is being driven for the driver to be protected by the free-wheeling diode.

Whenever a Zener diode is used between Vcom and the motor supply, the Vcom pin will slew from the coil supply to a voltage that is the sum of the Zener voltage and the coil supply when there is a flyback event. Depending on the coil inductance and resistance, this can be very rapid. Whenever the COM pin experiences a slew rate greater than 0.5 V/μs, a capacitor must be added to limit the slew to < 0.5 V/μs. See [Power Supply Recommendations](#) for further explanation.

8.2.2.2 Detailed Design Procedure

Refer to [Design Requirements](#).

8.2.2.3 Application Curves

Refer to [Thermal Characteristics](#).

8.2.3 Multi-Purpose Sink Driver

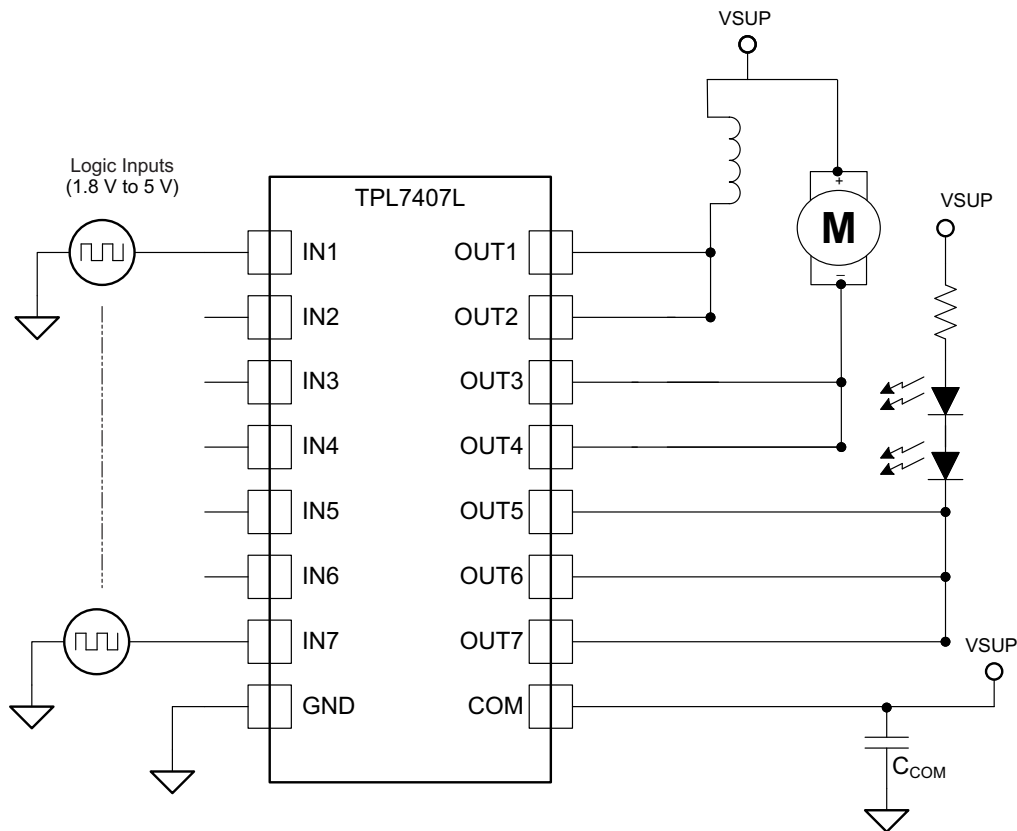

Figure 12. Multi-Purpose Sink Driver Schematic

8.2.3.1 Design Requirements

When configured as per [Figure 12](#) TPL7407L may be used as a multi-purpose driver. The output channels may be tied together to sink more current. TPL7407L can easily drive motors, relays & LEDs with little power dissipation. COM must be tied to highest load voltage, which may or may not be same as inductive load supply.

8.2.3.2 Detailed Design Procedure

Refer to [Design Requirements](#).

8.2.3.3 Application Curves

Refer to [Thermal Characteristics](#).

9 Power Supply Recommendations

The COM pin is the power supply pin of this device to power the gate drive circuitry. This ensures full drive potential with any GPIO above 1.5 V. The gate drive circuitry is based on low voltage CMOS transistors that can only handle a max gate voltage of 7 V. An integrated LDO reduces the COM voltage of 8.5 V to 40 V to a regulated voltage of 7 V. Though 8.5 V minimum is recommended for Vcom, the part will still function with a reduced COM voltage that has a reduced gate drive voltage and a resulting higher Rdson.

The COM pin must be limited to below 0.5 V/ μ s to prevent overvoltage on the internal LDO output due to a line transient on the COM pin. Faster slew-rate (or hot-plug) may cause damage to the internal gate driving circuitry due to the LDO's inability to clamp a fast input transient fast enough. Since most modern power supplies are loaded by capacitors > 10 μ F, this should not be of any concern. It is recommended to use a bypass capacitor that will limit the slew rate to below 0.5 V/ μ s.

Figure 11 is a great example where repetitive slew rates may occur on the Vcom pin. Whenever a Zener diode is used between Vcom and the motor supply, the Vcom pin will slew from the coil supply to a voltage that is the sum of the Zener voltage and the coil supply when there is a flyback event. Depending on the coil inductance and resistance, this can be very rapid.

In summary, whenever the COM pin may experience a slew rate greater than 0.5 V/ μ s a capacitor must be added to limit the slew to < 0.5 V/ μ s.

10 Layout

10.1 Layout Guidelines

Thin traces can be used on the input due to the low current logic that is typically used to drive TPL7407L. Care must be taken to separate the input channels as much as possible, as to eliminate cross-talk. Thick traces are recommended for the output, in order to drive whatever high currents that may be needed. Wire thickness can be determined by the trace material's current density and desired drive current.

Since all of the channels currents return to a common ground, it is best to size that trace width to be very wide. Some applications require up to 2 A.

Since the COM pin will only draw up to 25 μ A thick traces are not necessary.

10.2 Layout Example

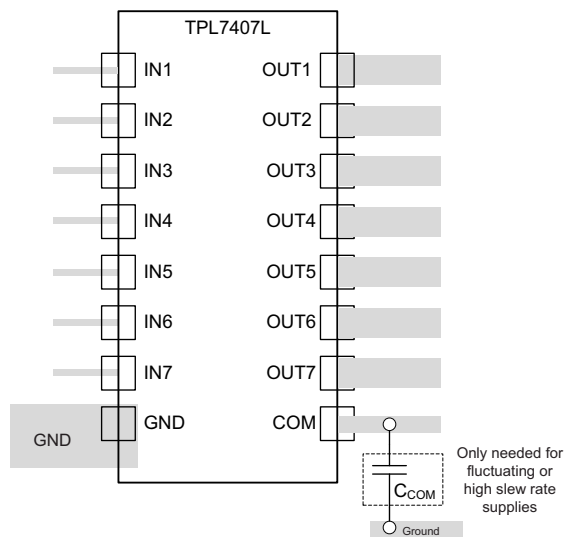

Figure 13. Package Layout

10.3 Thermal Considerations

The number of coils driven is dependent on the coil current and on-chip power dissipation. The number of coils driven can be determined by [Figure 3](#), [Figure 4](#), [Figure 5](#), [Figure 6](#), [Figure 7](#), or [Figure 8](#).

For a more accurate determination of number of coils possible, use the below equation to calculate TPL7407L on-chip power dissipation P_D :

$$P_D = \sum_{i=1}^N V_{OLi} \times I_{Li}$$

Where:

N is the number of channels active together.

V_{OLi} is the OUT_i pin voltage for the load current I_{Li} . This is the same as $V_{CE(SAT)}$ (2)

In order to guarantee reliability of TPL7407L and the system, the on-chip power dissipation must be lower than or equal to the maximum allowable power dissipation ($P_{D(MAX)}$) dictated by below equation [Equation 3](#).

$$P_{D(MAX)} = \frac{(T_{J(MAX)} - T_A)}{\theta_{JA}}$$

Where:

$T_{J(MAX)}$ is the target maximum junction temperature.

T_A is the operating ambient temperature.

θ_{JA} is the package junction to ambient thermal resistance. (3)

It is recommended to limit TPL7407L IC's die junction temperature to less than 125°C. The IC junction temperature is directly proportional to the on-chip power dissipation.

10.3.1 Improving Package Thermal Performance

θ_{JA} value depends on the PC board layout. An external heat sink and/or a cooling mechanism, like a cold air fan, can help reduce θ_{JA} and thus improve device thermal capabilities. Refer to TI's design support web page at www.ti.com/thermal for a general guidance on improving device thermal performance.

11 Device and Documentation Support

11.1 Community Resources

The following links connect to TI community resources. Linked contents are provided "AS IS" by the respective contributors. They do not constitute TI specifications and do not necessarily reflect TI's views; see TI's [Terms of Use](#).

TI E2E™ Online Community *TI's Engineer-to-Engineer (E2E) Community*. Created to foster collaboration among engineers. At e2e.ti.com, you can ask questions, share knowledge, explore ideas and help solve problems with fellow engineers.

Design Support *TI's Design Support* Quickly find helpful E2E forums along with design support tools and contact information for technical support.

11.2 Trademarks

E2E is a trademark of Texas Instruments.
All other trademarks are the property of their respective owners.

11.3 Electrostatic Discharge Caution



These devices have limited built-in ESD protection. The leads should be shorted together or the device placed in conductive foam during storage or handling to prevent electrostatic damage to the MOS gates.

11.4 Glossary

[SLYZ022](#) — *TI Glossary*.

This glossary lists and explains terms, acronyms, and definitions.

12 Mechanical, Packaging, and Orderable Information

The following pages include mechanical, packaging, and orderable information. This information is the most current data available for the designated devices. This data is subject to change without notice and revision of this document. For browser-based versions of this data sheet, refer to the left-hand navigation.

PACKAGING INFORMATION

Orderable Device	Status (1)	Package Type	Package Drawing	Pins	Package Qty	Eco Plan (2)	Lead/Ball Finish (6)	MSL Peak Temp (3)	Op Temp (°C)	Device Marking (4/5)	Samples
TPL7407LDR	ACTIVE	SOIC	D	16	2500	Green (RoHS & no Sb/Br)	SN	Level-1-260C-UNLIM	-40 to 125	TPL7407L	Samples
TPL7407LPWR	ACTIVE	TSSOP	PW	16	2000	Green (RoHS & no Sb/Br)	SN	Level-1-260C-UNLIM	-40 to 125	TPL7407L	Samples

(1) The marketing status values are defined as follows:

ACTIVE: Product device recommended for new designs.

LIFEBUY: TI has announced that the device will be discontinued, and a lifetime-buy period is in effect.

NRND: Not recommended for new designs. Device is in production to support existing customers, but TI does not recommend using this part in a new design.

PREVIEW: Device has been announced but is not in production. Samples may or may not be available.

OBSOLETE: TI has discontinued the production of the device.

(2) **RoHS:** TI defines "RoHS" to mean semiconductor products that are compliant with the current EU RoHS requirements for all 10 RoHS substances, including the requirement that RoHS substance do not exceed 0.1% by weight in homogeneous materials. Where designed to be soldered at high temperatures, "RoHS" products are suitable for use in specified lead-free processes. TI may reference these types of products as "Pb-Free".

RoHS Exempt: TI defines "RoHS Exempt" to mean products that contain lead but are compliant with EU RoHS pursuant to a specific EU RoHS exemption.

Green: TI defines "Green" to mean the content of Chlorine (Cl) and Bromine (Br) based flame retardants meet JS709B low halogen requirements of <=1000ppm threshold. Antimony trioxide based flame retardants must also meet the <=1000ppm threshold requirement.

(3) MSL, Peak Temp. - The Moisture Sensitivity Level rating according to the JEDEC industry standard classifications, and peak solder temperature.

(4) There may be additional marking, which relates to the logo, the lot trace code information, or the environmental category on the device.

(5) Multiple Device Markings will be inside parentheses. Only one Device Marking contained in parentheses and separated by a "-" will appear on a device. If a line is indented then it is a continuation of the previous line and the two combined represent the entire Device Marking for that device.

(6) Lead/Ball Finish - Orderable Devices may have multiple material finish options. Finish options are separated by a vertical ruled line. Lead/Ball Finish values may wrap to two lines if the finish value exceeds the maximum column width.

Important Information and Disclaimer:The information provided on this page represents TI's knowledge and belief as of the date that it is provided. TI bases its knowledge and belief on information provided by third parties, and makes no representation or warranty as to the accuracy of such information. Efforts are underway to better integrate information from third parties. TI has taken and continues to take reasonable steps to provide representative and accurate information but may not have conducted destructive testing or chemical analysis on incoming materials and chemicals. TI and TI suppliers consider certain information to be proprietary, and thus CAS numbers and other limited information may not be available for release.

In no event shall TI's liability arising out of such information exceed the total purchase price of the TI part(s) at issue in this document sold by TI to Customer on an annual basis.

TAPE AND REEL INFORMATION



QUADRANT ASSIGNMENTS FOR PIN 1 ORIENTATION IN TAPE



*All dimensions are nominal

Device	Package Type	Package Drawing	Pins	SPQ	Reel Diameter (mm)	Reel Width W1 (mm)	A0 (mm)	B0 (mm)	K0 (mm)	P1 (mm)	W (mm)	Pin1 Quadrant
TPL7407LDR	SOIC	D	16	2500	330.0	16.8	6.5	10.3	2.1	8.0	16.0	Q1
TPL7407LPWR	TSSOP	PW	16	2000	330.0	12.4	6.9	5.6	1.6	8.0	12.0	Q1

TAPE AND REEL BOX DIMENSIONS

*All dimensions are nominal

Device	Package Type	Package Drawing	Pins	SPQ	Length (mm)	Width (mm)	Height (mm)
TPL7407LDR	SOIC	D	16	2500	364.0	364.0	27.0
TPL7407LPWR	TSSOP	PW	16	2000	364.0	364.0	27.0

D (R-PDSO-G16)

PLASTIC SMALL OUTLINE



- NOTES:
- A. All linear dimensions are in inches (millimeters).
 - B. This drawing is subject to change without notice.
 - C. Body length does not include mold flash, protrusions, or gate burrs. Mold flash, protrusions, or gate burrs shall not exceed 0.006 (0,15) each side.
 - D. Body width does not include interlead flash. Interlead flash shall not exceed 0.017 (0,43) each side.
 - E. Reference JEDEC MS-012 variation AC.

D (R-PDSO-G16)

PLASTIC SMALL OUTLINE



- NOTES:
- All linear dimensions are in millimeters.
 - This drawing is subject to change without notice.
 - Publication IPC-7351 is recommended for alternate designs.
 - Laser cutting apertures with trapezoidal walls and also rounding corners will offer better paste release. Customers should contact their board assembly site for stencil design recommendations. Refer to IPC-7525 for other stencil recommendations.
 - Customers should contact their board fabrication site for solder mask tolerances between and around signal pads.



4220204/A 02/2017

NOTES:

1. All linear dimensions are in millimeters. Any dimensions in parenthesis are for reference only. Dimensioning and tolerancing per ASME Y14.5M.
2. This drawing is subject to change without notice.
3. This dimension does not include mold flash, protrusions, or gate burrs. Mold flash, protrusions, or gate burrs shall not exceed 0.15 mm per side.
4. This dimension does not include interlead flash. Interlead flash shall not exceed 0.25 mm per side.
5. Reference JEDEC registration MO-153.

EXAMPLE BOARD LAYOUT

PW0016A

TSSOP - 1.2 mm max height

SMALL OUTLINE PACKAGE



LAND PATTERN EXAMPLE
EXPOSED METAL SHOWN
SCALE: 10X



4220204/A 02/2017

NOTES: (continued)

- 6. Publication IPC-7351 may have alternate designs.
- 7. Solder mask tolerances between and around signal pads can vary based on board fabrication site.

EXAMPLE STENCIL DESIGN

PW0016A

TSSOP - 1.2 mm max height

SMALL OUTLINE PACKAGE



SOLDER PASTE EXAMPLE
BASED ON 0.125 mm THICK STENCIL
SCALE: 10X

4220204/A 02/2017

NOTES: (continued)

8. Laser cutting apertures with trapezoidal walls and rounded corners may offer better paste release. IPC-7525 may have alternate design recommendations.
9. Board assembly site may have different recommendations for stencil design.

IMPORTANT NOTICE AND DISCLAIMER

TI PROVIDES TECHNICAL AND RELIABILITY DATA (INCLUDING DATASHEETS), DESIGN RESOURCES (INCLUDING REFERENCE DESIGNS), APPLICATION OR OTHER DESIGN ADVICE, WEB TOOLS, SAFETY INFORMATION, AND OTHER RESOURCES "AS IS" AND WITH ALL FAULTS, AND DISCLAIMS ALL WARRANTIES, EXPRESS AND IMPLIED, INCLUDING WITHOUT LIMITATION ANY IMPLIED WARRANTIES OF MERCHANTABILITY, FITNESS FOR A PARTICULAR PURPOSE OR NON-INFRINGEMENT OF THIRD PARTY INTELLECTUAL PROPERTY RIGHTS.

These resources are intended for skilled developers designing with TI products. You are solely responsible for (1) selecting the appropriate TI products for your application, (2) designing, validating and testing your application, and (3) ensuring your application meets applicable standards, and any other safety, security, or other requirements. These resources are subject to change without notice. TI grants you permission to use these resources only for development of an application that uses the TI products described in the resource. Other reproduction and display of these resources is prohibited. No license is granted to any other TI intellectual property right or to any third party intellectual property right. TI disclaims responsibility for, and you will fully indemnify TI and its representatives against, any claims, damages, costs, losses, and liabilities arising out of your use of these resources.

TI's products are provided subject to TI's Terms of Sale (www.ti.com/legal/termsofsale.html) or other applicable terms available either on ti.com or provided in conjunction with such TI products. TI's provision of these resources does not expand or otherwise alter TI's applicable warranties or warranty disclaimers for TI products.

Mailing Address: Texas Instruments, Post Office Box 655303, Dallas, Texas 75265
Copyright © 2020, Texas Instruments Incorporated