

60V Dual Output Step-Down Controller with Digital Power System Management

FEATURES

- **PMBus/I²C Compliant Serial Interface**
 - Telemetry Read-Back Includes V_{IN} , I_{IN} , V_{OUT} , I_{OUT} , Temperature and Faults
 - Programmable Voltage, Current Limit, Digital Soft-Start/Stop, Sequencing, Margining, OV/UV/OC, Frequency, and Control Loop Compensation
- **Output Error Less Than $\pm 0.5\%$ Over Temperature**
- **Integrated 16-Bit ADC and 12-Bit DAC**
- **Integrated High Side Current Sense Amplifier**
- **Internal EEPROM with ECC and Fault Logging**
- **Integrated N-Channel MOSFET Gate Drivers**

Power Conversion

- **Wide V_{IN} Range: 5V to 60V**
- **V_{OUT0} , V_{OUT1} Range: 1V to 40V**
- **Analog Current Mode Control**
- **Accurate PolyPhase[®] Current Sharing for Up to 6 Phases (85kHz to 500kHz)**
- **Available in a 52-Lead (7mm \times 8mm) QFN Package**

APPLICATIONS

- **Telecom, Datacom, and Storage Systems**
- **Industrial and Point of Load Applications**

DESCRIPTION

The **LTC[®]3889** is a dual PolyPhase DC/DC synchronous step-down switching regulator controller with I²C-based **PMBus compliant serial interface**. This controller employs a constant-frequency, current-mode architecture, with high voltage input and output capability along with programmable loop compensation. The LTC3889 is supported by the **LTpowerPlay[™]** software development tool with graphical user interface (GUI).

The $EXTV_{CC}$ pin supports voltages up to 14V allowing for optimized circuit efficiency and die temperature, and for the controller output to supply the chip power. Switching frequency, output voltage, and device address can be programmed both by digital interface as well as external configuration resistors. Parameters can be set via the digital interface or stored in EEPROM. Both outputs have an independent power good indicator and **FAULT** function.

The LTC3889 can be configured for discontinuous (pulse-skipping) mode or continuous inductor current mode.

All registered trademarks and trademarks are the property of their respective owners. Protected by U.S. Patents including 5481178, 5705919, 5929620, 6100678, 6144194, 6177787, 5408150, 6580258, 6304066, 7420359, 8786268 Patent Pending. Licensed under U.S. Patent 7000125 and other related patents worldwide.

TYPICAL APPLICATION

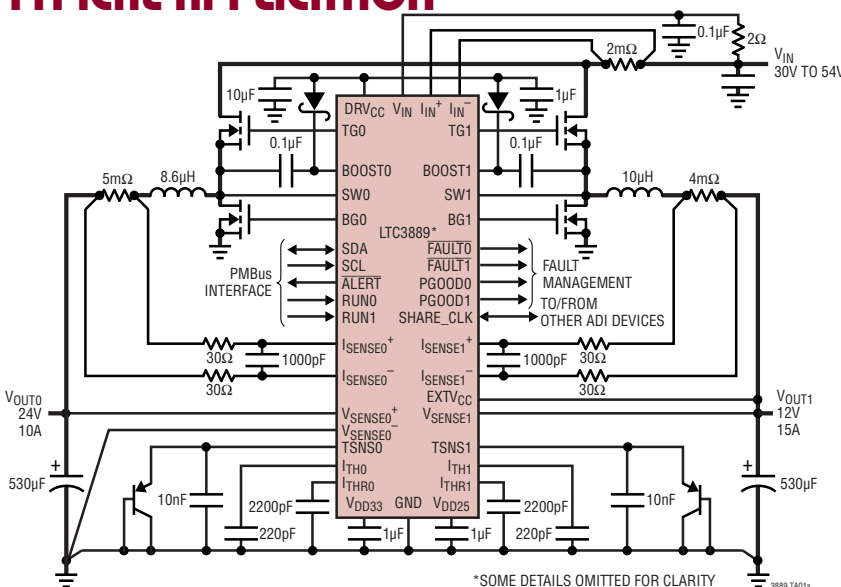

| | V_{IN} RANGE (V) | V_{OUT} RANGE (V) | GATE DRIVE (V) | LTC3870 COMPATIBLE | T_{ON_MIN} (ns) |
|---------|--------------------|---------------------|----------------|--------------------|--------------------|
| LTC3889 | 5 to 60 | 1 to 40 | 6.3 to 9 | No | 45 |
| LTC3886 | 4.5 to 60 | 0.5 to 13.8 | 5 | Yes | 90 |

Efficiency and Power Loss vs Load Current

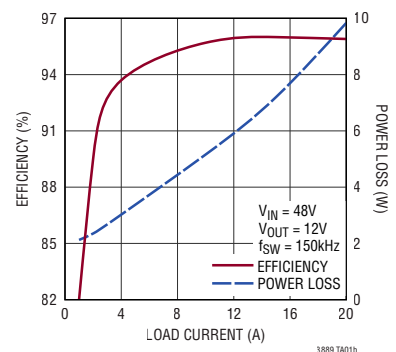

TABLE OF CONTENTS

| | | | |
|--|-----------|---|-----------|
| Features | 1 | Responses to V_{OUT} and I_{OUT} Faults | 27 |
| Applications | 1 | Output Overvoltage Fault Response | 27 |
| Typical Application | 1 | Output Undervoltage Response | 27 |
| Description | 1 | Peak Output Overcurrent Fault Response | 28 |
| Table of Contents | 2 | Responses to Timing Faults..... | 28 |
| Absolute Maximum Ratings | 4 | Responses to V_{IN} OV Faults..... | 28 |
| Order Information | 4 | Responses to OT/UT Faults..... | 28 |
| Pin Configuration | 4 | Internal Overtemperature Fault/Warn Response | 28 |
| Electrical Characteristics | 5 | External Overtemperature and | |
| Typical Performance Characteristics | 10 | Undertemperature Fault Response | 29 |
| Pin Functions | 13 | Responses to External Faults | 29 |
| Block Diagram | 15 | Fault Logging | 29 |
| Operation | 16 | Bus Timeout Protection | 29 |
| Overview..... | 16 | Similarity Between PMBus, SMBus and I ² C | |
| Main Control Loop..... | 16 | 2-Wire Interface..... | 30 |
| EEPROM | 17 | PMBus Serial Digital Interface | 30 |
| CRC Protection | 17 | PMBus Command Summary | 35 |
| Power-Up and Initialization | 18 | PMBus Commands | 35 |
| Soft-Start..... | 18 | Applications Information | 40 |
| Time-Based Sequencing | 19 | Current Limit Programming..... | 40 |
| Event-Based Sequencing | 19 | I _{SENSE} ⁺ and I _{SENSE} ⁻ Pins..... | 40 |
| Shutdown | 19 | Low Value Resistor Current Sensing..... | 41 |
| Light-Load Current Operation | 20 | Inductor DCR Current Sensing..... | 42 |
| PWM Loop Compensation..... | 20 | Slope Compensation and Inductor Peak Current ... | 43 |
| Switching Frequency and Phase | 20 | Inductor Value Calculation | 43 |
| Output Voltage Sensing | 21 | Inductor Core Selection | 44 |
| Output Current Sensing | 21 | Power MOSFET and Optional Schottky Diode | |
| Input Current Sensing..... | 21 | Selection..... | 44 |
| PolyPhase Load Sharing..... | 22 | C _{IN} and C _{OUT} Selection | 45 |
| External/Internal Temperature Sense..... | 22 | Variable Delay Time, Soft-Start and Output Voltage | |
| RCONFIG (Resistor Configuration) Pins..... | 23 | Ramping | 45 |
| Fault Handling..... | 23 | Digital Servo Mode | 46 |
| Status Registers and ALERT Masking..... | 24 | Soft Off (Sequenced Off) | 47 |
| Mapping Faults to FAULT Pins..... | 26 | DRV _{CC} Regulator | 48 |
| Power Good Pins..... | 26 | Topside MOSFET Driver Supply (C _B , D _B) | 48 |
| Serial Interface | 26 | Undervoltage Lockout..... | 49 |
| Communication Protection | 26 | Fault Indications | 49 |
| Device Addressing | 26 | Open-Drain Pins | 50 |

TABLE OF CONTENTS

| | | | |
|---|-----------|--|------------|
| Phase-Locked Loop and Frequency Synchronization | 50 | Output Current and Limits | 80 |
| Minimum On-Time Considerations | 51 | Input Current and Limits | 82 |
| External Temperature Sense | 51 | Temperature | 83 |
| Derating EEPROM Retention at Temperature | 52 | External Temperature Calibration | 83 |
| Input Current Sense Amplifier | 53 | Timing | 84 |
| External Resistor Configuration Pins (RCONFIG) | 53 | Timing—On Sequence/Ramp | 84 |
| Voltage Selection | 53 | Timing—Off Sequence/Ramp | 85 |
| Frequency Selection | 54 | Precondition for Restart | 86 |
| Phase Selection | 55 | Fault Response | 87 |
| Address Selection Using RCONFIG | 55 | Fault Responses All Faults | 87 |
| Efficiency Considerations | 55 | Fault Responses Input Voltage | 87 |
| Programmable Loop Compensation | 56 | Fault Responses Output Voltage | 87 |
| Checking Transient Response | 57 | Fault Responses Output Current | 91 |
| PolyPhase Configuration | 58 | Fault Responses IC Temperature | 92 |
| PC Board Layout Checklist | 60 | Fault Responses External Temperature | 93 |
| PC Board Layout Debugging | 60 | Fault Sharing | 94 |
| Design Example | 62 | Fault Sharing Propagation | 94 |
| Additional Design Checks | 63 | Fault Sharing Response | 96 |
| Connecting the USB to I ² C/SMBus/PMBus Adapter to the LTC3889 In System | 63 | Scratchpad | 96 |
| LTpowerPlay: An Interactive GUI for Digital Power | 64 | Identification | 97 |
| PMBus Communication and Command Processing | 65 | Fault Warning and Status | 98 |
| PMBus Command Details | 67 | Telemetry | 105 |
| Addressing and Write Protect | 67 | EEPROM Memory Commands | 109 |
| General Configuration COMMANDS | 69 | Store/Restore | 109 |
| On/Off/Margin | 70 | Fault Logging | 110 |
| PWM Configuration | 72 | Fault Log Operation | 110 |
| Voltage | 76 | Block Memory Write/Read | 115 |
| Input Voltage and Limits | 76 | Typical Applications | 116 |
| Output Voltage and Limits | 77 | Package Description | 119 |
| | | Typical Application | 120 |
| | | Related Parts | 120 |

ABSOLUTE MAXIMUM RATINGS

(Note 1)

| | |
|--|-----------------|
| V_{IN} , I_{IN}^+ , I_{IN}^- | -0.3V to 65V |
| Top Gate Transient Voltage (TGO, TG1) | -0.3V to 76V |
| BOOST0, BOOST1 | -0.3V to 76V |
| Switch Transient Voltage (SW0, SW1) | -5V to 65V |
| DRV_{CC} , BG0, BG1, (BOOST0– SW0), (BOOST1– SW1) | -0.3V to 11V |
| V_{SENSE0}^+ , V_{SENSE1}^+ , I_{SENSE0}^+ , I_{SENSE1}^+ , I_{SENSE0}^- , I_{SENSE1}^- | -0.3V to 42V |
| V_{SENSE0}^- | -0.3V to 0.3V |
| $EXTV_{CC}$ | -0.3V to 15V |
| ($EXTV_{CC} - V_{IN}$) | 13.2V |
| RUN, SDA, SCL, \overline{ALERT} | -0.3V to 5.5V |
| $ASEL_n$, V_{OUTn_CFG} , $FREQ_CFG$, $PHAS_CFG$, V_{DD25} | -0.3V to 2.75V |
| ($V_{IN} - I_{INP}$), ($V_{IN} - I_{INM}$), ($V_{SENSE0}^+ - I_{SENSE0}^+$), ($V_{SENSE0}^+ - I_{SENSE0}^-$), ($V_{SENSE1}^+ - I_{SENSE1}^+$), ($V_{SENSE1}^+ - I_{SENSE1}^-$) | -0.3V to 0.3V |
| PGOOD0, PGOOD1, FAULT, SHARE_CLK, I_{TH0} , I_{TH1} , I_{THRO} , I_{THR1} , V_{DD33} , WP, TSNS0, TSNS1, SYNC | -0.3V to 3.6V |
| DRV_{CC} Peak Output Current | 100mA |
| Operating Junction Temperature Range (Note 2) | -40°C to 125°C* |
| Storage Temperature Range | -65°C to 150°C* |

* See Derating EEPROM Retention at Temperature in the Applications Information section for junction temperatures in excess of 125°C.

PIN CONFIGURATION

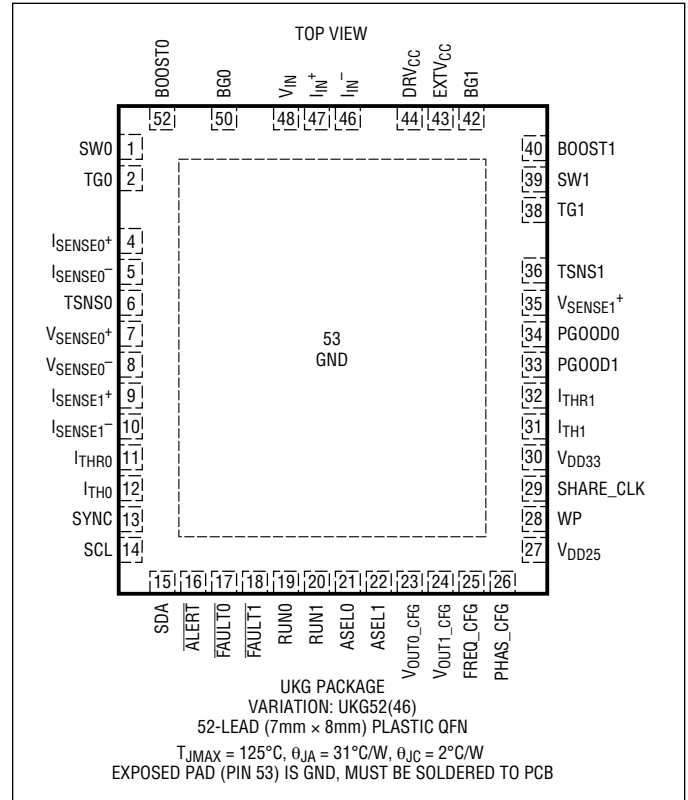

Note: Pins omitted to achieve high input voltage rating.

ORDER INFORMATION

| LEAD FREE FINISH | TAPE AND REEL | PART MARKING* | PACKAGE DESCRIPTION | TEMPERATURE RANGE (SEE NOTE 2) |
|------------------|--------------------|---------------|---------------------------------|--------------------------------|
| LTC3889EUKG#PBF | LTC3889EUKG#TRPBF | LTC3889UKG | 52-Lead (7mm × 8mm) Plastic QFN | -40°C to 125°C |
| LTC3889IUUKG#PBF | LTC3889IUUKG#TRPBF | LTC3889UKG | 52-Lead (7mm × 8mm) Plastic QFN | -40°C to 125°C |

Contact the factory for parts specified with wider operating temperature ranges. *The temperature grade is identified by a label on the shipping container.

[Tape and reel specifications](#). Some packages are available in 500 unit reels through designated sales channels with #TRMPBF suffix.

ELECTRICAL CHARACTERISTICS The ● denotes the specifications which apply over the specified operating junction temperature range, otherwise specifications are at $T_J = 25^\circ\text{C}$ (Note 2). $V_{IN} = 16\text{V}$, $\text{EXTV}_{CC} = 0\text{V}$, $V_{RUN0} = 1.8\text{V}$, $V_{RUN1} = 1.8\text{V}$, $f_{\text{SYNC}} = 250\text{kHz}$ (externally driven), and all programmable parameters at factory default unless otherwise specified.

| SYMBOL | PARAMETER | CONDITIONS | MIN | TYP | MAX | UNITS |
|---|---|--|--------|---------------------------|-------------|----------------------------------|
| Input Voltage | | | | | | |
| V_{IN} | Input Voltage Range | (Note 12) | ● | 5 | 60 | V |
| I_Q | Input Voltage Supply Current Normal Operation | (Note 14) $V_{RUN} = 3.3\text{V}$, No Caps on TG and BG $V_{RUN} = 0\text{V}$ | | 26 20 | | mA mA |
| V_{UVLO} | Undervoltage Lockout Threshold When $V_{IN} > 4.2\text{V}$ | V_{DRVCC} Falling V_{DRVCC} Rising | | 3.7 3.95 | | V V |
| T_{INIT} | Initialization Time | Delay from RESTORE_USER_ALL, MFR_REST, or $V_{DRVCC} > V_{UVLO}$ Until TON_DELAY Can Begin | | 35 | | ms |
| Control Loop | | | | | | |
| V_{OUTR0} | Range 0 Maximum V_{OUT} Range 0 Set Point Accuracy Range 0 Resolution Range 0 LSB Step Size, FSR = 41.48V | $6\text{V} \leq V_{OUT} \leq 38\text{V}$ (Notes 9, 10) | ● | -0.5 12 10 | 40 0.5 | V % Bits mV |
| V_{OUTR1} | Range 1 Maximum V_{OUT} Range 1 Set Point Accuracy Range 1 Resolution Range 1 LSB Step Size, FSR = 8.30V | $3\text{V} \leq V_{OUT} \leq 8\text{V}$ (Notes 9, 10) | ● | -0.5 12 2 | 8 0.5 | V % Bits mV |
| $V_{LINEREG}$ | Line Regulation | $16\text{V} < V_{IN} < 60\text{V}$ | ● | | ± 0.02 | %/V |
| $V_{LOADREG}$ | Load Regulation | $\Delta V_{ITH} = 1.35\text{V} - 0.7\text{V}$ $\Delta V_{ITH} = 1.35\text{V} - 2.0\text{V}$ | ● ● | 0.01 -0.01 | 0.1 -0.1 | % % |
| $g_{m0,1}$ | Resolution Error Amplifier $g_{m(\text{MAX})}$ Error Amplifier $g_{m(\text{MIN})}$ Error Amplifier g_m LSB Step Size | $I_{TH} = 1.35\text{V}$ $I_{TH} = 1.35\text{V}$ $I_{TH} = 1.35\text{V}$ | | 3 5.76 1.00 0.68 | | bits mmho mmho mmho |
| $R_{ITHR0,1}$ | Resolution Compensation Resistor $R_{ITHR(\text{MAX})}$ Compensation Resistor $R_{ITHR(\text{MIN})}$ | | | 5 62 0 | | bits k Ω k Ω |
| I_{ISENSE} | Input Current | $V_{ISENSE} = 40\text{V}$ | ● | ± 1 | ± 2 | μA |
| $V_{I(LIMIT)}$ | Resolution $V_{ILIM(\text{MAX})}$ $V_{ILIM(\text{MIN})}$ | Hi Range Lo Range Hi Range Lo Range | ● ● | 68 44 37.5 25 | 75 50 | 82 56 mV mV |
| Gate Driver ($\text{DRV}_{CC} = 9\text{V}$) | | | | | | |
| TG t_r t_f | TG Transition Time: Rise Time Fall Time | (Note 4) $C_{LOAD} = 3300\text{pF}$ $C_{LOAD} = 3300\text{pF}$ | | 30 30 | | ns ns |
| BG t_r t_f | BG Transition Time: Rise Time Fall Time | (Note 4) $C_{LOAD} = 3300\text{pF}$ $C_{LOAD} = 3300\text{pF}$ | | 20 20 | | ns ns |
| TG/BG t_{1D} | Top Gate Off to Bottom Gate On Delay Time | (Note 4) $C_{LOAD} = 3300\text{pF}$ | | 50 | | ns |
| BG/TG t_{2D} | Bottom Gate Off to Top Gate On Delay Time | (Note 4) $C_{LOAD} = 3300\text{pF}$ | | 50 | | ns |
| $t_{ON(\text{MIN})}$ | Minimum On-Time | | | 45 | | ns |

ELECTRICAL CHARACTERISTICS The ● denotes the specifications which apply over the specified operating junction temperature range, otherwise specifications are at $T_J = 25^\circ\text{C}$ (Note 2). $V_{IN} = 16\text{V}$, $\text{EXTV}_{CC} = 0\text{V}$, $V_{RUN0} = 1.8\text{V}$, $V_{RUN1} = 1.8\text{V}$, $f_{\text{SYNC}} = 250\text{kHz}$ (externally driven), and all programmable parameters at factory default unless otherwise specified.

| SYMBOL | PARAMETER | CONDITIONS | MIN | TYP | MAX | UNITS |
|--|---|---|-----|-----------------------------------|----------|------------------------------|
| OV/UV Output Voltage Supervisor | | | | | | |
| N | Resolution | | | 9 | | Bits |
| V_{RANGE0} | Range 0 Maximum Threshold | | | 40 | | V |
| V_{RANGE1} | Range 1 Maximum Threshold | | | 8 | | V |
| V_{OUSTP0} | Range 0 Step Size, FSR = 41.48V | (Note 10) | | 81 | | mV |
| V_{OUSTP1} | Range 1 Step Size, FSR = 8.30V | | | 16.2 | | mV |
| V_{THACC0} | Range 0 Threshold Accuracy | $6\text{V} < V_{\text{OUT}} < 38\text{V}$ | ● | | ±2.5 | % |
| V_{THACC1} | Range 1 Threshold Accuracy | $2.5\text{V} < V_{\text{OUT}} < 8\text{V}$ | ● | | ±2.5 | % |
| t_{PROPOV1} | OV Comparator to FAULT Low Time | $V_{\text{OD}} = 10\%$ of Threshold | | | 35 | μs |
| t_{PROPUV1} | UV Comparator to FAULT Low Time | $V_{\text{OD}} = 10\%$ of Threshold | | | 35 | μs |
| V_{IN} Voltage Supervisor | | | | | | |
| N | Resolution | | | 9 | | Bits |
| $V_{\text{IN(RANGE)}}$ | Maximum Threshold | (Note 11) | | 31.56 | | V |
| $V_{\text{IN(STP)}}$ | Step Size | | | 61.6 | | mV |
| $V_{\text{IN(THACCH)}}$ | Threshold Accuracy $6\text{V} < V_{\text{IN}} < 30\text{V}$ | | ● | | ±3 | % |
| $t_{\text{PROP(VIN)}}$ | Comparator Response Time ($V_{\text{IN_ON}}$ and $V_{\text{IN_OFF}}$) | $V_{\text{OD}} = 10\%$ of Threshold | | | 100 | μs |
| Output Voltage Readback | | | | | | |
| N | Resolution LSB Step Size | | | 16 977 | | Bits μV |
| $V_{\text{F/S}}$ | Full-Scale Sense Voltage | (Note 10) $V_{\text{RUN}} = 0\text{V}$ (Note 8) | | 45 | | V |
| $V_{\text{OUT_TUE}}$ | Total Unadjusted Error | $T_J = 25^\circ\text{C}$, $3\text{V} < V_{\text{OUT}} < 38\text{V}$ (Note 8) | ● | 0.2 | ±0.5 | % % |
| V_{OS} | Zero-Code Offset Voltage | | ● | | ±2 | mV |
| t_{CONVERT} | Conversion Time | (Note 6) | | 90 | | ms |
| V_{IN} Voltage Readback | | | | | | |
| N | Resolution | (Note 5) | | 10 | | Bits |
| $V_{\text{F/S}}$ | Full-Scale Input Voltage | (Note 11) | | 66.56 | | V |
| $V_{\text{IN_TUE}}$ | Total Unadjusted Error | $T_J = 25^\circ\text{C}$, $5\text{V} < V_{\text{IN}} < 60\text{V}$ | ● | | 0.5 2 | % % |
| t_{CONVERT} | Conversion Time | (Note 6) | | 90 | | ms |
| Output Current Readback | | | | | | |
| N | Resolution LSB Step Size | (Note 5) $0\text{V} \leq V_{\text{ISENSE}^+} - V_{\text{ISENSE}^-} < 16\text{mV}$ $16\text{mV} \leq V_{\text{ISENSE}^+} - V_{\text{ISENSE}^-} < 32\text{mV}$ $32\text{mV} \leq V_{\text{ISENSE}^+} - V_{\text{ISENSE}^-} < 64\text{mV}$ $64\text{mV} \leq V_{\text{ISENSE}^+} - V_{\text{ISENSE}^-} < 100\text{mV}$ | | 10 15.26 30.52 61 122 | | Bits μV μV μV μV |
| $I_{\text{F/S}}$ | Full-Scale Output Current | (Note 7) $R_{\text{ISENSE}} = 1\text{m}\Omega$ | | ±100 | | A |
| $I_{\text{OUT_TUE}}$ | Total Unadjusted Error | (Note 8) $10\text{mV} \leq V_{\text{ISENSE}} \leq 100\text{mV}$ | ● | | ±1.5 | % |
| V_{OS} | Zero-Code Offset Voltage | | | | ±32 | μV |
| t_{CONVERT} | Conversion Time | (Note 6) | | 90 | | ms |

ELECTRICAL CHARACTERISTICS The ● denotes the specifications which apply over the specified operating junction temperature range, otherwise specifications are at $T_J = 25^\circ\text{C}$ (Note 2). $V_{IN} = 16\text{V}$, $\text{EXTV}_{CC} = 0\text{V}$, $V_{RUN0} = 1.8\text{V}$, $V_{RUN1} = 1.8\text{V}$, $f_{\text{SYNC}} = 250\text{kHz}$ (externally driven), and all programmable parameters at factory default unless otherwise specified.

| SYMBOL | PARAMETER | CONDITIONS | MIN | TYP | MAX | UNITS |
|---|--|---|-------------|----------------------------|-------------------------------------|---|
| Input Current Readback | | | | | | |
| N | Resolution LSB Step Size, Full-Scale Range = 16mV LSB Step Size, Full-Scale Range = 32mV LSB Step Size, Full-Scale Range = 64mV | (Note 5) 8x Gain, $0\text{V} \leq I_{IN}^+ - I_{IN}^- \leq 5\text{mV}$ 4x Gain, $0\text{V} \leq I_{IN}^+ - I_{IN}^- \leq 20\text{mV}$ 2x Gain, $0\text{V} \leq I_{IN}^+ - I_{IN}^- \leq 50\text{mV}$ | | 10 15.26 30.52 61 | | Bits μV μV μV |
| I_{IN_TUE} | Total Unadjusted Error (Note 8) | 8x Gain, $2.5\text{mV} \leq I_{IN}^+ - I_{IN}^- \leq 5\text{mV}$ 4x Gain, $4\text{mV} \leq I_{IN}^+ - I_{IN}^- \leq 20\text{mV}$ 2x Gain, $6\text{mV} \leq I_{IN}^+ - I_{IN}^- \leq 50\text{mV}$ | ● ● ● | | ± 1.6 ± 1.3 ± 1.2 | % % % |
| I_{IIN} | Input Current, I_{IN}^+ and I_{IN}^- | $V_{VIN} = V_{IIN+} = V_{IIN-} = 60\text{V}$ | ● | | ± 2 | μA |
| V_{OS} | Zero-Code Offset Voltage | | | | ± 50 | μV |
| t_{CONVERT} | Conversion Time | (Note 6) | | 90 | | ms |
| Supply Current Readback | | | | | | |
| N | Resolution LSB Step Size, Full-Scale Range = 256mV | (Note 5) | | 10 244 | | Bits μV |
| $I_{\text{CHIP_TUE}}$ | Total Unadjusted Error | $20\text{mV} \leq I_{IN}^+ - V_{IN} \leq 200\text{mV}$ | ● | | ± 2.5 | % |
| t_{CONVERT} | Conversion Time | (Note 6) | | 90 | | ms |
| Temperature Readback (T0, T1) | | | | | | |
| $T_{\text{RES_T}}$ | Resolution | | | 0.25 | | $^\circ\text{C}$ |
| $T0_TUE$ | External TSNS TUE (Note 8) MFR_PWM_MODE_LTC3889[5] = 0 MFR_PWM_MODE_LTC3889[5] = 1 | $\Delta V_{\text{TSNS}} = 72\text{mV}$ (Note 17) $V_{\text{TSNS}} \leq 1.85\text{V}$ (Note 17) | ● ● | | ± 3 ± 7 | $^\circ\text{C}$ $^\circ\text{C}$ |
| $T1_TUE$ | Internal TSNS TUE | $V_{\text{RUN}} = 0.0\text{V}$, $f_{\text{SYNC}} = 0\text{kHz}$ (Note 8) | | | ± 1 | $^\circ\text{C}$ |
| $t_{\text{CONVERT_T}}$ | Update Rate | (Note 6) | | 90 | | ms |
| DRV_{CC} Regulator | | | | | | |
| $V_{\text{DRVCC_VIN}}$ | DRV _{CC} Voltage No Load | $8\text{V} < V_{IN} < 60\text{V}$, $\text{DRVSET} = 0$ $11\text{V} < V_{IN} < 60\text{V}$, $\text{DRVSET} = 1$ $11\text{V} < V_{IN} < 60\text{V}$, $\text{DRVSET} = 2$ | | 6.1 7.2 8.6 | 6.3 7.4 9 | 6.5 7.6 9.4 V V V |
| $V_{\text{LDO_VIN}}$ | DRV _{CC} Load Regulation | $I_{CC} = 0\text{mA}$ to 50mA, $\text{EXTV}_{CC} = 0$, $\text{DRVSET} = 2$ | | 0.5 | ± 2 | % |
| $V_{\text{DRVCC_EXT}}$ | DRV _{CC} Voltage No Load | $7\text{V} < \text{EXTV}_{CC} < 14\text{V}$, $\text{DRVSET} = 0$ $11\text{V} < \text{EXTV}_{CC} < 14\text{V}$, $\text{DRVSET} = 1$ $11\text{V} < \text{EXTV}_{CC} < 14\text{V}$, $\text{DRVSET} = 2$ | | 6.1 7.2 8.6 | 6.3 7.4 9 | 6.5 7.6 9.4 V V V |
| $V_{\text{LDO_EXT}}$ | DRV _{CC} Load Regulation | $I_{CC} = 0\text{mA}$ to 50mA, $\text{EXTV}_{CC} = 12\text{V}$, $\text{DRVSET} = 2$ | | 0.5 | ± 2 | % |
| $V_{\text{EXT_THRES}}$ | EXTV _{CC} Switchover Voltage | EXTV _{CC} Ramping Positive, $\text{DRVSET} = 0$ EXTV _{CC} Ramping Positive, $\text{DRVSET} = 1, 2$ | ● ● | 5.0 7.4 | 5.35 7.7 | 5.6 8.0 V V |
| $V_{\text{EXT_HYS}}$ | EXTV _{CC} Hysteresis Voltage | | | 110 | | mV |
| V_{DD33} Regulator | | | | | | |
| V_{DD33} | Internal V _{DD33} Voltage | $5.0\text{V} < V_{\text{DRVCC}}$ | | 3.2 | 3.3 | 3.4 V |
| I_{LIM} | V _{DD33} Current Limit | $V_{\text{DD33}} = \text{GND}$, $V_{IN} = V_{\text{DRVCC}} = 5.0\text{V}$ | | | 35 | mA |
| $V_{\text{DD33_OV}}$ | V _{DD33} Overvoltage Threshold | | | | 3.5 | V |
| $V_{\text{DD33_UV}}$ | V _{DD33} Undervoltage Threshold | | | | 3.1 | V |
| V_{DD25} Regulator | | | | | | |
| V_{DD25} | Internal V _{DD25} Voltage | | | 2.5 | | V |
| I_{LIM} | V _{DD25} Current Limit | $V_{\text{DD25}} = \text{GND}$, $V_{\text{DD33}} = 3.6\text{V}$ | | | 80 | mA |
| Oscillator and Phase-Locked Loop | | | | | | |
| f_{OSC} | Oscillator Frequency Accuracy | $85\text{kHz} < f_{\text{SYNC}} < 500\text{kHz}$ Measured Falling Edge-to-Falling Edge of SYNC with $\text{FREQUENCY_SWITCH} = 85\text{kHz}$ and 500.0kHz | ● | | ± 10 | % |

ELECTRICAL CHARACTERISTICS The ● denotes the specifications which apply over the specified operating junction temperature range, otherwise specifications are at $T_J = 25^\circ\text{C}$ (Note 2). $V_{IN} = 16\text{V}$, $\text{EXTV}_{CC} = 0\text{V}$, $V_{RUN0} = 1.8\text{V}$, $V_{RUN1} = 1.8\text{V}$, $f_{\text{SYNC}} = 250\text{kHz}$ (externally driven), and all programmable parameters at factory default unless otherwise specified.

| SYMBOL | PARAMETER | CONDITIONS | MIN | TYP | MAX | UNITS |
|---------------------------------|---|---|-----|---------------------------------|---------|---------------------------------|
| $V_{\text{TH(SYNC)}}$ | SYNC Input Threshold | V_{CLKIN} Falling V_{CLKIN} Rising | | 1 1.5 | | V V |
| $V_{\text{OL(SYNC)}}$ | SYNC Low Output Voltage | $I_{\text{LOAD}} = 2.5\text{mA}$ | ● | 0.2 | 0.4 | V |
| $I_{\text{LEAK(SYNC)}}$ | SYNC Leakage Current in Slave Mode | $0\text{V} \leq V_{\text{PIN}} \leq 3.6\text{V}$ | | | ± 5 | μA |
| $\theta_{\text{SYNC-}\theta 0}$ | SYNC to Channel 0 Phase Relationship Based on the Falling Edge of Sync and Rising Edge of TGO | MFR_PWM_CONFIG_LTC3889[2:0] = 0,2,3 MFR_PWM_CONFIG_LTC3889[2:0] = 5 MFR_PWM_CONFIG_LTC3889[2:0] = 1 MFR_PWM_CONFIG_LTC3889[2:0] = 4,6 | | 0 60 90 120 | | Deg Deg Deg Deg |
| $\theta_{\text{SYNC-}\theta 1}$ | SYNC to Channel 1 Phase Relationship Based on the Falling Edge of Sync and Rising Edge of TG1 | MFR_PWM_CONFIG_LTC3889[2:0] = 3 MFR_PWM_CONFIG_LTC3889[2:0] = 0 MFR_PWM_CONFIG_LTC3889[2:0] = 2,4,5 MFR_PWM_CONFIG_LTC3889[2:0] = 1 MFR_PWM_CONFIG_LTC3889[2:0] = 6 | | 120 180 240 270 300 | | Deg Deg Deg Deg Deg |

EEPROM Characteristics

| | | | | | | |
|------------|---------------------------|--|---|--------|------|--------|
| Endurance | (Note 13) | $0^\circ\text{C} < T_J < 85^\circ\text{C}$ During EEPROM Write Operations | ● | 10,000 | | Cycles |
| Retention | (Note 13) | $T_J < 125^\circ\text{C}$ | ● | 10 | | Years |
| Mass_Write | Mass Write Operation Time | STORE_USER_ALL, $0^\circ\text{C} < T_J \leq 85^\circ\text{C}$ During EEPROM Write Operations | ● | 440 | 4100 | ms |

Digital Inputs SCL, SDA, RUN n , FAULT n

| | | | | | | |
|-------------------|------------------------------|----------------------|---|------|------|----|
| V_{IH} | Input High Threshold Voltage | SCL, SDA, RUN, FAULT | ● | | 1.35 | V |
| V_{IL} | Input Low Threshold Voltage | SCL, SDA, RUN, FAULT | ● | 0.8 | | V |
| V_{HYST} | Input Hysteresis | SCL, SDA | | 0.08 | | V |
| C_{PIN} | Input Capacitance | | | | 10 | pF |

Digital Input WP

| | | | | | | |
|-------------------|-----------------------|----|--|----|--|---------------|
| I_{PUWP} | Input Pull-Up Current | WP | | 10 | | μA |
|-------------------|-----------------------|----|--|----|--|---------------|

Open-Drain Outputs SCL, SDA, FAULT n , ALERT, RUN n , SHARE_CLK, PGOOD n

| | | | | | | |
|-----------------|--------------------|--------------------------------|---|--|-----|---|
| V_{OL} | Output Low Voltage | $I_{\text{SINK}} = 3\text{mA}$ | ● | | 0.4 | V |
|-----------------|--------------------|--------------------------------|---|--|-----|---|

Digital Inputs SHARE_CLK, WP

| | | | | | | |
|-----------------|------------------------------|--|---|-----|-----|---|
| V_{IH} | Input High Threshold Voltage | | ● | 1.5 | 1.8 | V |
| V_{IL} | Input Low Threshold Voltage | | ● | 0.6 | 1.0 | V |

Leakage Current SDA, SCL, ALERT, RUN

| | | | | | | |
|-----------------|-----------------------|--|---|--|---------|---------------|
| I_{OL} | Input Leakage Current | $0\text{V} \leq V_{\text{PIN}} \leq 5.5\text{V}$ | ● | | ± 5 | μA |
|-----------------|-----------------------|--|---|--|---------|---------------|

Leakage Current FAULT n , PGOOD n

| | | | | | | |
|-----------------|-----------------------|--|---|--|---------|---------------|
| I_{GL} | Input Leakage Current | $0\text{V} \leq V_{\text{PIN}} \leq 3.6\text{V}$ | ● | | ± 2 | μA |
|-----------------|-----------------------|--|---|--|---------|---------------|

Digital Filtering of FAULT n

| | | | | | | |
|--------------------|-----------------------------------|--|--|---|--|---------------|
| t_{FAULT} | Input Digital Filtering FAULT n | | | 3 | | μs |
|--------------------|-----------------------------------|--|--|---|--|---------------|

Digital Filtering of PGOOD n

| | | | | | | |
|--------------------|------------------------------------|--|--|----|--|---------------|
| t_{PGOOD} | Output Digital Filtering PGOOD n | | | 60 | | μs |
|--------------------|------------------------------------|--|--|----|--|---------------|

Digital Filtering of RUN n

| | | | | | | |
|------------------|---------------------------------|--|--|----|--|---------------|
| t_{RUN} | Input Digital Filtering RUN n | | | 10 | | μs |
|------------------|---------------------------------|--|--|----|--|---------------|

PMBus Interface Timing Characteristics

| | | | | | | |
|----------------------|--|--|---|-----|-----|---------------|
| f_{SCL} | Serial Bus Operating Frequency | | ● | 10 | 400 | kHz |
| t_{BUF} | Bus Free Time Between Stop and Start | | ● | 1.3 | | μs |
| $t_{\text{HD(STA)}}$ | Hold Time After Start Condition. After This Period, the First Clock Is Generated | | ● | 0.6 | | μs |

ELECTRICAL CHARACTERISTICS

The ● denotes the specifications which apply over the specified operating junction temperature range, otherwise specifications are at $T_J = 25^\circ\text{C}$ (Note 2). $V_{IN} = 16\text{V}$, $\text{EXTV}_{CC} = 0\text{V}$, $V_{RUN0} = 1.8\text{V}$, $V_{RUN1} = 1.8\text{V}$, $f_{\text{SYNC}} = 250\text{kHz}$ (externally driven), and all programmable parameters at factory default unless otherwise specified.

| SYMBOL | PARAMETER | CONDITIONS | MIN | TYP | MAX | UNITS |
|---------------------------|-------------------------------------|--|--------|--------|-------|---------------|
| $t_{\text{SU(STA)}}$ | Repeated Start Condition Setup Time | | ● | 0.6 | 10000 | μs |
| $t_{\text{SU(STO)}}$ | Stop Condition Setup Time | | ● | 0.6 | | μs |
| $t_{\text{HD(DAT)}}$ | Data Hold Time | | | 0 | | μs |
| | Receiving Data Transmitting Data | | ● ● | 0.3 | 0.9 | μs |
| $t_{\text{SU,DAT}}$ | Data Setup Time Receiving Data | | ● | 0.1 | | μs |
| $t_{\text{TIMEOUT_SMB}}$ | Stuck PMBus Timer Non-Block Reads | Measured from the Last PMBus Start Event | | 32/255 | | ms |
| | Stuck PMBus Timer Block Reads | | | 255 | | ms |
| t_{LOW} | Serial Clock Low Period | | ● | 1.3 | 10000 | μs |
| t_{HIGH} | Serial Clock High Period | | ● | 0.6 | | μs |

Note 1: Stresses beyond those listed under Absolute Maximum Ratings may cause permanent damage to the device. Exposure to any Absolute Maximum Rating condition for extended periods may affect device reliability and lifetime.

Note 2: The LTC3889 is tested under pulsed load conditions such that $T_J \approx T_A$. The LTC3889E is guaranteed to meet performance specifications from 0°C to 85°C . Specifications over the -40°C to 125°C operating junction temperature range are assured by design, characterization and correlation with statistical process controls. The LTC3889I is guaranteed over the -40°C to 125°C operating junction temperature range. T_J is calculated from the ambient temperature, T_A , and power dissipation, P_D , according to the following formula:

$$T_J = T_A + (P_D \cdot \theta_{JA})$$

The maximum ambient temperature consistent with these specifications is determined by specific operating conditions in conjunction with board layout, the rated package thermal impedance and other environmental factors.

Note 3: All currents into device pins are positive; all currents out of device pins are negative. All voltages are referenced to ground unless otherwise specified.

Note 4: Rise and fall times are measured using 10% and 90% levels. Delay times are measured using 50% levels.

Note 5: The data format in PMBus is 5 bits exponent (signed) and 11 bits mantissa (signed). This limits the output resolution to 10 bits though the internal ADC is 16 bits and the calculations use 32-bit words.

Note 6: The data conversion is done in round robin fashion. All input signals are continuously converted for a typical latency of 90ms unless the MFR_ADC_CONTROL command is utilized.

Note 7: The IOUT_CAL_GAIN = 1.0m Ω and MFR_IOUT_TC = 0.0. Value as read from READ_IOUT in amperes.

Note 8: Part tested with PWM disabled. Evaluation in application demonstrates capability. TUE (%) = ADC Gain Error (%) + 100 • [Zero Code Offset + ADC Linearity Error]/Actual Value.

Note 9: All V_{OUT} commands assume the ADC is used to auto-zero the output to achieve the stated accuracy. LTC3889 is tested in a feedback loop that servos V_{OUT} to a specified value.

Note 10: The maximum programmable V_{OUT} voltage is 40V.

Note 11: The maximum V_{IN} voltage is 60V.

Note 12: When $V_{\text{IN}} < 6\text{V}$, DRV_{CC} must be tied to V_{IN} .

Note 13: EEPROM endurance is guaranteed by design, characterization and correlation with statistical process controls. Data retention is production tested via a high temperature bake at wafer level. The minimum retention specification applies for devices whose EEPROM has been cycled less than the minimum endurance specification. The RESTORE_USER_ALL command (EEPROM read) is valid over the entire operating temperature range.

Note 14: The LTC3889 quiescent current (I_Q) equals the I_Q of V_{IN} plus the I_Q of EXTV_{CC} .

Note 15: The LTC3889 includes overtemperature protection that is intended to protect the device during momentary overload conditions. Junction temperature will exceed 125°C when overtemperature protection is active. Continuous operation above the specified maximum operating junction temperature may impair device reliability.

Note 16: Write operations above $T_J = 85^\circ\text{C}$ or below 0°C are possible although the Electrical Characteristics are not guaranteed and the EEPROM will be degraded. Read operations performed at temperatures between -40°C and 125°C will not degrade the EEPROM. Writing to the EEPROM above 85°C will result in a degradation of retention characteristics.

Note 17: Limits guaranteed by TSNS voltage and current measurements during test, including ADC readback.

TYPICAL PERFORMANCE CHARACTERISTICS

$T_A = 25^\circ\text{C}$, $V_{IN} = 16\text{V}$, $\text{EXTV}_{CC} = 0\text{V}$, unless otherwise noted.

Efficiency vs Load Current, $V_{OUT} = 5\text{V}$

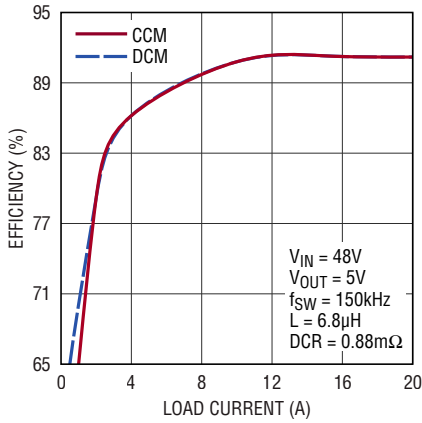

3889 G01

Efficiency vs Load Current, $V_{OUT} = 24\text{V}$

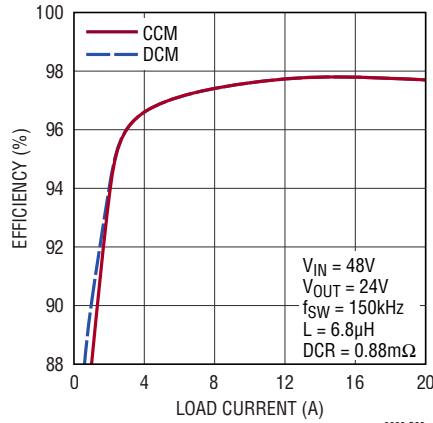

3889 G02

Efficiency and Power Loss vs Input Voltage

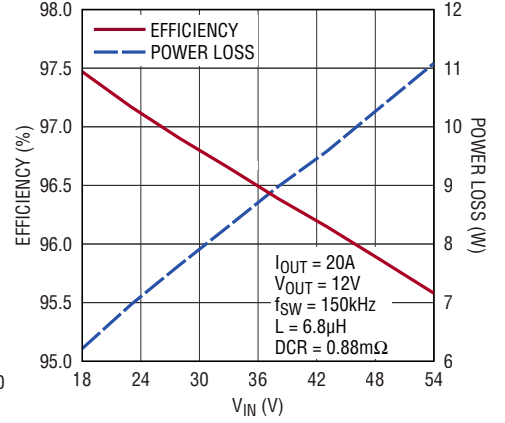

3889 G03

EXTV_{CC} Switchover vs Temperature

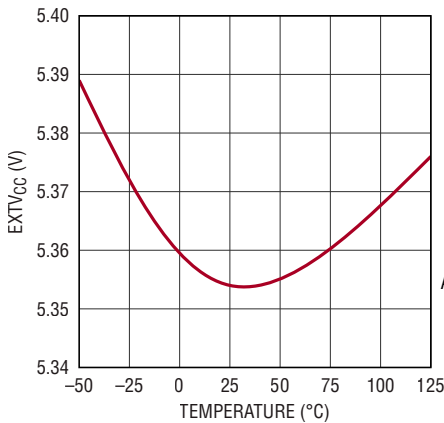

3889 G04

Load Step (Forced Continuous Mode)

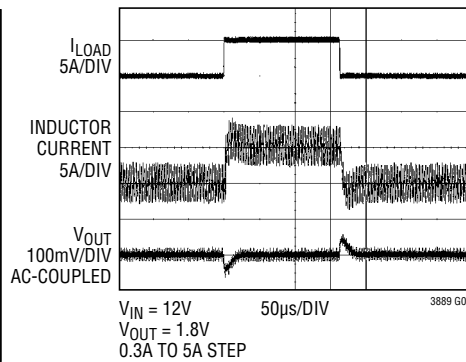

3889 G05

Load Step (Pulse-Skipping Mode)

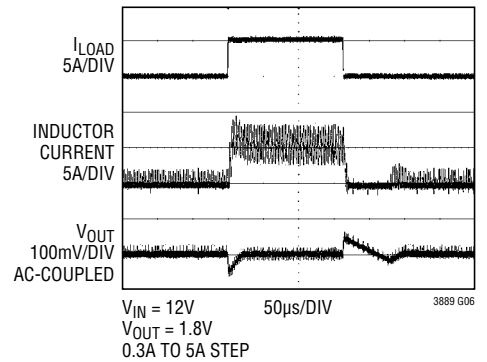

3889 G06

Inductor Current at Light Load

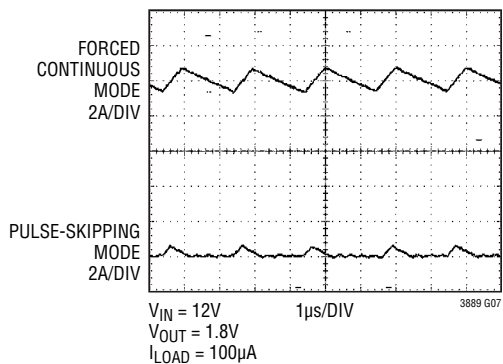

3889 G07

Start-Up into a Pre-Biased Load

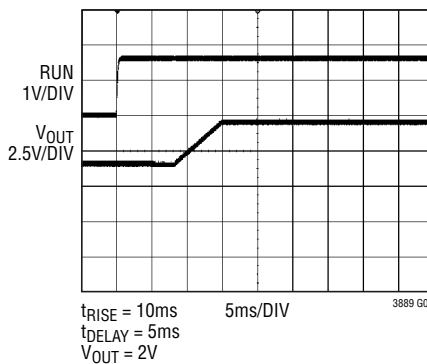

3889 G08

Soft-Start Ramp

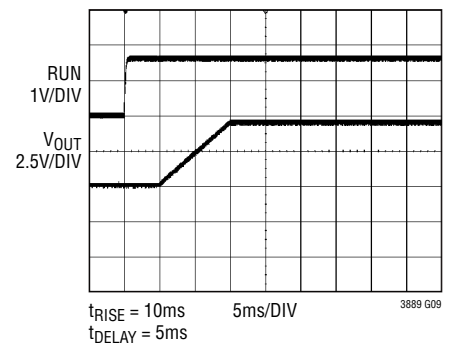

3889 G09

TYPICAL PERFORMANCE CHARACTERISTICS

$T_A = 25^\circ\text{C}$, $V_{IN} = 16\text{V}$, $\text{EXTV}_{CC} = 0\text{V}$, unless otherwise noted.

Soft-Off Ramp

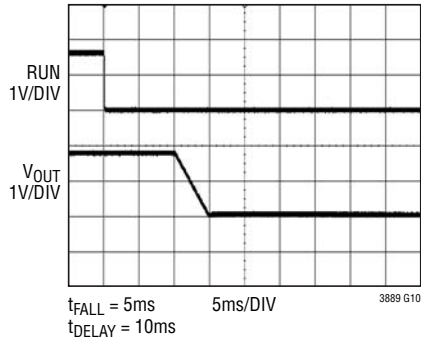

Regulated 2.5V Output Voltage vs Temperature

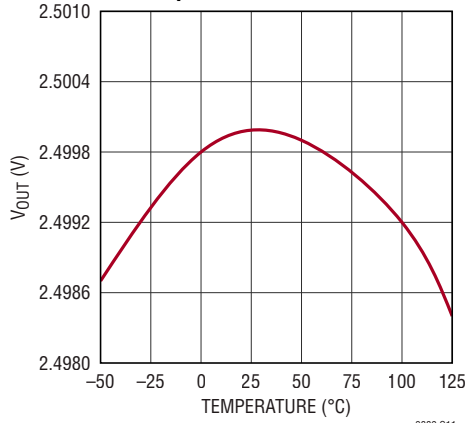

Maximum Current Sense Threshold vs Duty Cycle, $V_{OUT} = 0\text{V}$

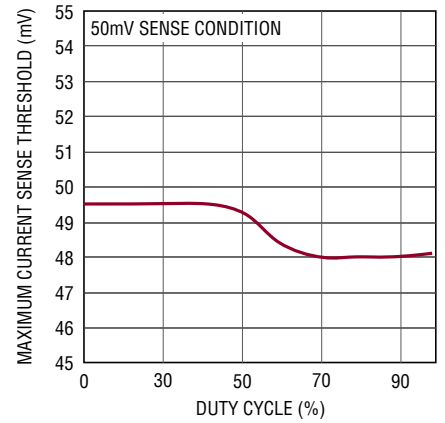

SHARE_CLK Frequency vs Temperature

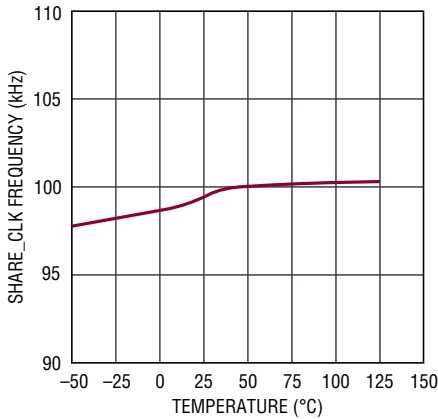

Quiescent Current vs Temperature

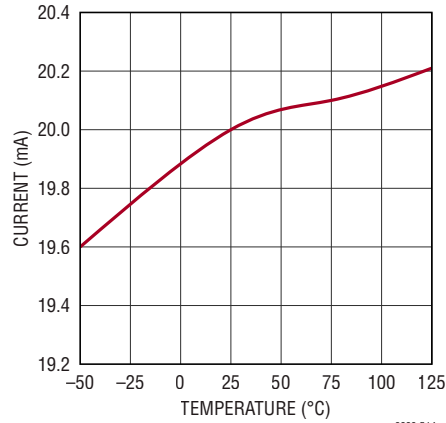

V_{OUT} Measurement Error vs V_{OUT}

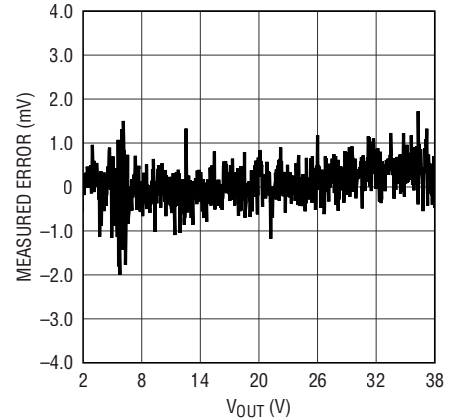

V_{OUT} Command INL

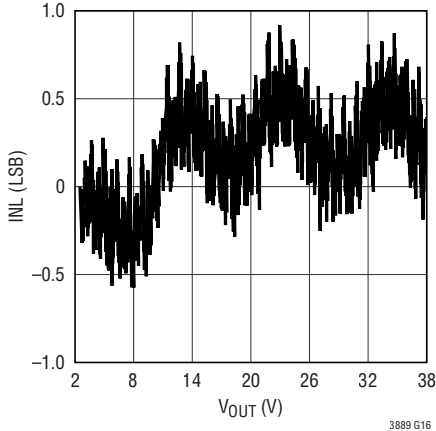

V_{OUT} Command DNL

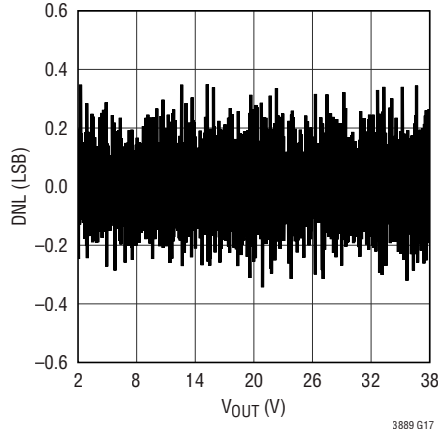

DRV_{CC} Line Regulation

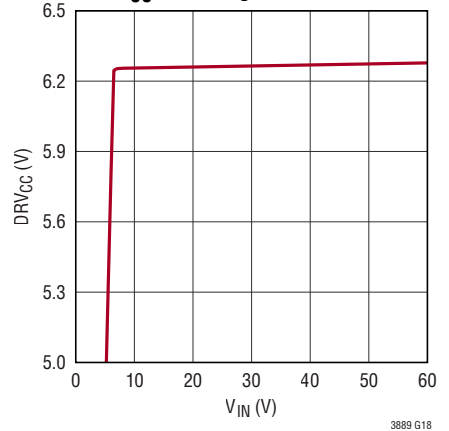

TYPICAL PERFORMANCE CHARACTERISTICS

$T_A = 25^\circ\text{C}$, $V_{IN} = 16\text{V}$, $\text{EXTV}_{CC} = 0\text{V}$, unless otherwise noted.

V_{OUT} OV Threshold vs Temperature (2.5V Target)

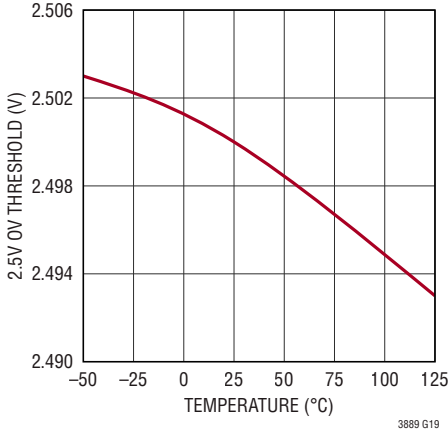

V_{OUT} OV Threshold vs Temperature (12V Target)

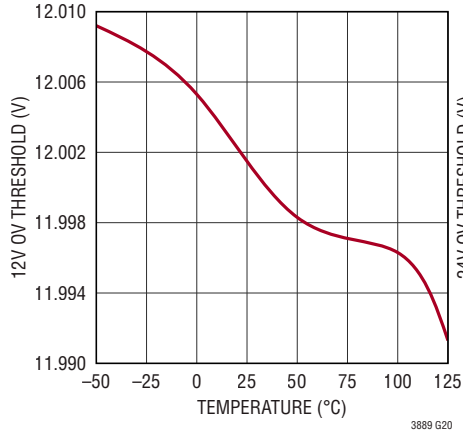

V_{OUT} OV Threshold vs Temperature (24V Target)

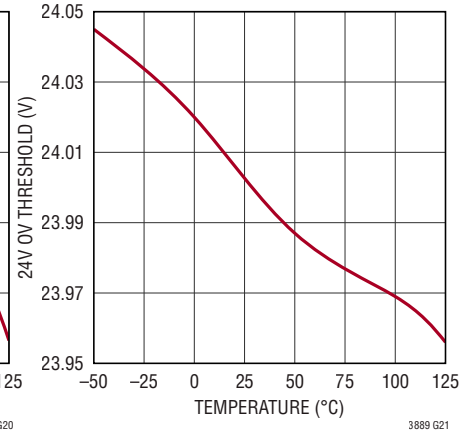

External Temperature Error vs Temperature

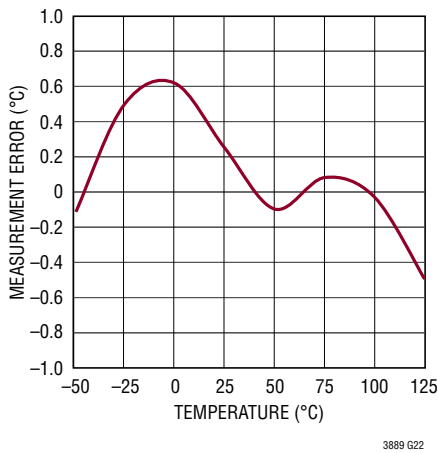

I_{OUT} Error vs I_{OUT}

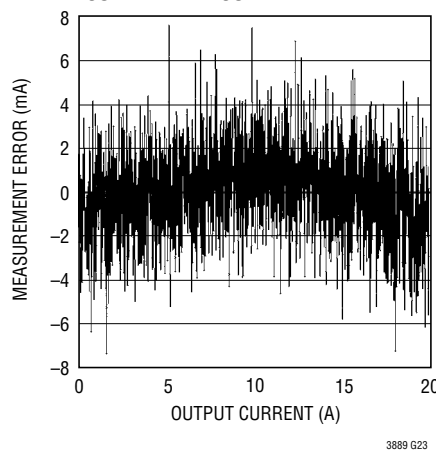

I_{IN} Error vs I_{IN}

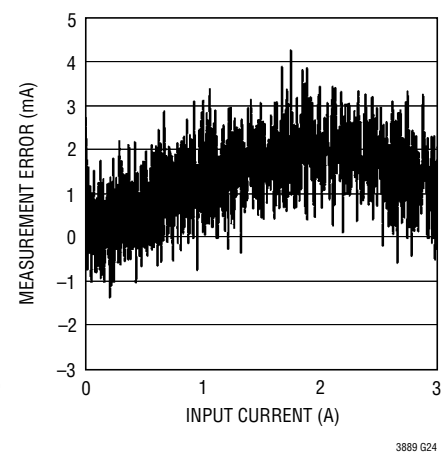

DC Output Current Matching in a 2-Phase System (LTC3889)

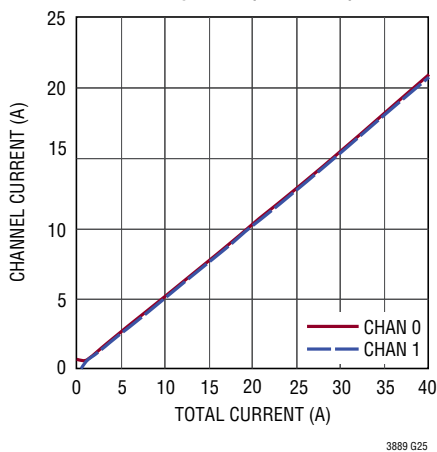

Dynamic Current Sharing During a Load Transient in a 4-Phase System

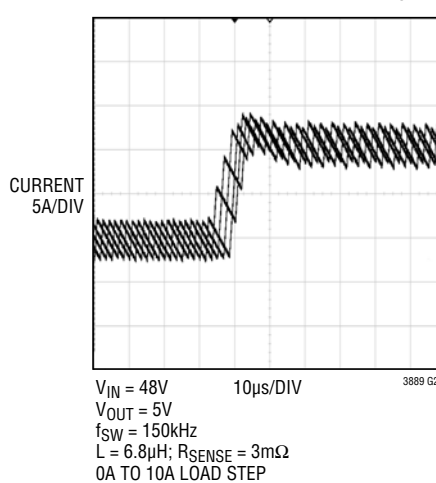

Dynamic Current Sharing During a Load Transient in a 4-Phase System

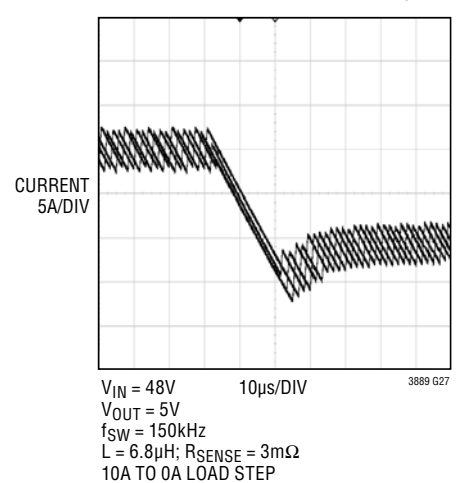

PIN FUNCTIONS

SW0/SW1 (Pins 1, 39): Switch Node Connections to Inductors. Voltage swings at the pins are from a Schottky diode (external) voltage drop below ground to V_{IN} .

TG0/TG1 (Pins 2, 38): Top Gate Driver Outputs. These are the outputs of floating drivers with a voltage swing equal to DRV_{CC} superimposed on the switch node voltages.

$I_{SENSE0}^+/I_{SENSE1}^+$ (Pins 4, 9): Current Sense Comparator Inputs. The (+) input to the current comparator is normally connected to the DCR sensing network or current sensing resistor.

$I_{SENSE0}^-/I_{SENSE1}^-$ (Pins 5, 10): Current Sense Comparator Inputs. The (-) input is connected to the output.

TSNS0/TSNS1 (Pins 6, 36): External Diode Temperature Sense. Connect to the anode of a diode-connected PNP transistor in order to sense remote temperature. Directly connect the cathode using a separate ground return path to Pin 53 of the LTC3889. A bypass capacitor between the anode and cathode must be located in close proximity to the transistor. If external temperature sense elements are not installed, short pin to ground and set the UT_FAULT_LIMIT to -275°C and the $UT_FAULT_RESPONSE$ to ignore.

$V_{SENSE0}^+/V_{SENSE1}^+$ (Pins 7, 35): Positive Output Voltage Sense Inputs.

V_{SENSE0}^- (Pin 8): Channel 0 Negative Output Voltage Sense Input.

I_{THR0}/I_{THR1} (Pins 11, 32): Loop Compensation Nodes.

I_{TH0}/I_{TH1} (Pins 12, 31): Current Control Threshold and Error Amplifier Compensation Nodes. Each associated channel's current comparator tripping threshold increases with its I_{TH} voltage.

SYNC (Pin 13): External Clock Synchronization Input and Open-Drain Output Pin. If an external clock is present at this pin, the switching frequency will be synchronized to the external clock. If clock master mode is enabled, this pin will pull low at the switching frequency with a 500ns pulse width to ground. A resistor pull-up to 3.3V is required in the application.

SCL (Pin 14): Serial Bus Clock Input. Open-drain output, can hold the output low if clock stretching is enabled. A pull-up resistor to a voltage between 1.8V to 3.3V is required in the application.

SDA (Pin 15): Serial Bus Data Input and Output. A pull-up resistor to a voltage between 1.8V to 3.3V is required in the application.

ALERT (Pin 16): Open-Drain Digital Output. Connect the $\overline{\text{SMBALERT}}$ signal to this pin. A pull-up resistor to 3.3V is required in the application.

FAULT0/FAULT1 (Pins 17, 18): Digital Programmable General Purpose Inputs and Outputs. Open-drain output. A pull-up resistor to a voltage between 1.8V to 3.3V is required in the application.

RUN0/RUN1 (Pins 19, 20): Enable Run Input and Output. Logic high on this pin enables the controller. Open-drain output holds the pin low until the LTC3889 is out of reset. This pin should be driven by an open-drain digital output. A pull-up resistor to a voltage between 1.8V to 3.3V is required in the application.

ASEL0/ASEL1 (Pin 21/Pin 22): Serial Bus Address Select Inputs. Connect optional 1% resistor dividers between V_{DD25} and GND to these pins to select the serial bus interface address. Refer to the Applications Information section for more detail. Minimize capacitance when the pin is open to assure accurate detection of the pin state.

$V_{OUT_CFG0}/V_{OUT_CFG1}$ (Pins 23, 24): Output Voltage Select Pins. Connect a $\pm 1\%$ resistor divider between the chip V_{DD25} , V_{OUT_CFG} and GND in order to select output voltage. If the pin is left open, the IC will use the value programmed in the EEPROM. Refer to the Applications Information section for more detail. Minimize capacitance when the pin is open to assure accurate detection of the pin state.

FREQ_CFG (Pin 25): Frequency Select Pin. Connect a $\pm 1\%$ resistor divider between the chip V_{DD25} FREQ_CFG and GND in order to select switching frequency. If the pin is left open, the IC will use the value programmed in the EEPROM. Refer to the Applications Information section for more detail. Minimize capacitance when the pin is open to assure accurate detection of the pin state.

PIN FUNCTIONS

PHAS_CFG (Pin 26): Phase Configuration Input. Connect an optional 1% resistor divider between V_{DD25} and GND to this pin to configure the phase of each PWM channel relative to SYNC. Refer to the Applications Information section for more detail. Minimize capacitance when the pin is open to assure accurate detection of the pin state.

V_{DD25} (Pin 27): Internally Generated 2.5V Power Supply Output. Bypass this pin to GND with a low ESR 1 μ F capacitor. Do not load this pin externally except for the resistor dividers needed for the LTC3889 resistor configuration pins.

WP (Pin 28): Write Protect Pin Active High. An internal 10 μ A current source pulls the pin to V_{DD33} . If WP is high, the PMBus writes are restricted.

SHARE_CLK (Pin 29): Share Clock, Bidirectional Open-Drain Clock Sharing Pin. Nominally 100kHz. Used to synchronize the timing between multiple ADI controllers. Tie all the SHARE_CLK pins together. All ADI controllers will synchronize to the fastest clock. A pull-up resistor of 5.49k to 3.3V is required in the application.

V_{DD33} (Pin 30): Internally Generated 3.3V Power Supply Output. Bypass this pin to GND with a low ESR 1 μ F capacitor. Do not load this pin with external current.

PGOOD0/PGOOD1 (Pins 34, 33): Power Good Indicator Outputs. Open-drain logic output that is pulled to ground when the output exceeds OV/UV thresholds. The output is deglitched by an internal 60 μ s filter. A pull-up resistor to 3.3V is required in the application.

BOOST1/BOOST0 (Pins 40, 52): Boosted Floating Driver Supplies. The (+) terminal of the booststrap capacitor connects to this pin. This pin swings from a diode voltage drop below DRV_{CC} up to $V_{IN} + DRV_{CC}$.

BG0/BG1 (Pins 50, 42): Bottom Gate Driver Outputs. This pin drives the gates of the bottom N-channel MOSFET between GND and DRV_{CC} .

EXTV_{CC} (Pin 43): External power input to an internal LDO connected to DRV_{CC} . This LDO supplies DRV_{CC} power bypassing the internal LDO powered from V_{IN} whenever $EXTV_{CC}$ is higher than 5.3V (7.7V if $DRVSET = 1, 2$). See $EXTV_{CC}$ connection in the Applications Information Section. Do not float or exceed 14V on this pin. Decouple this pin to GND with a minimum of 4.7 μ F low ESR tantalum or ceramic capacitor. If the $EXTV_{CC}$ pin is not used, tie the pin to GND. The $EXTV_{CC}$ pin may be connected to a higher voltage than the V_{IN} pin.

DRV_{CC} (Pin 44): Output of the V_{IN} or $EXTV_{CC}$ Low Dropout (LDO) Regulators. The gate drivers are powered from this voltage source. The DRV_{CC} output voltage is set by the $DRVSET$ value. The DRV_{CC} pin must be decoupled to ground with a minimum of 4.7 μ F ceramic or other low ESR capacitor. Do not use the DRV_{CC} pin for any other purpose.

I_{IN}^- (Pin 46): Negative Input of High Side Current Sense Amplifier.

I_{IN}^+ (Pin 47): Positive Input of High Side Current Sense Amplifier.

V_{IN} (Pin 48): Main Input Supply. Decouple this pin to GND with a capacitor (0.1 μ F to 1 μ F). For applications where the main input power is 5V, tie the V_{IN} and DRV_{CC} pins together. If the input current sense amplifier is not used, this pin must be shorted to the I_{IN}^+ and I_{IN}^- pins.

GND (Exposed Pad Pin 53): Ground. All small-signal and compensation components should connect to this ground, at one point.

BLOCK DIAGRAM

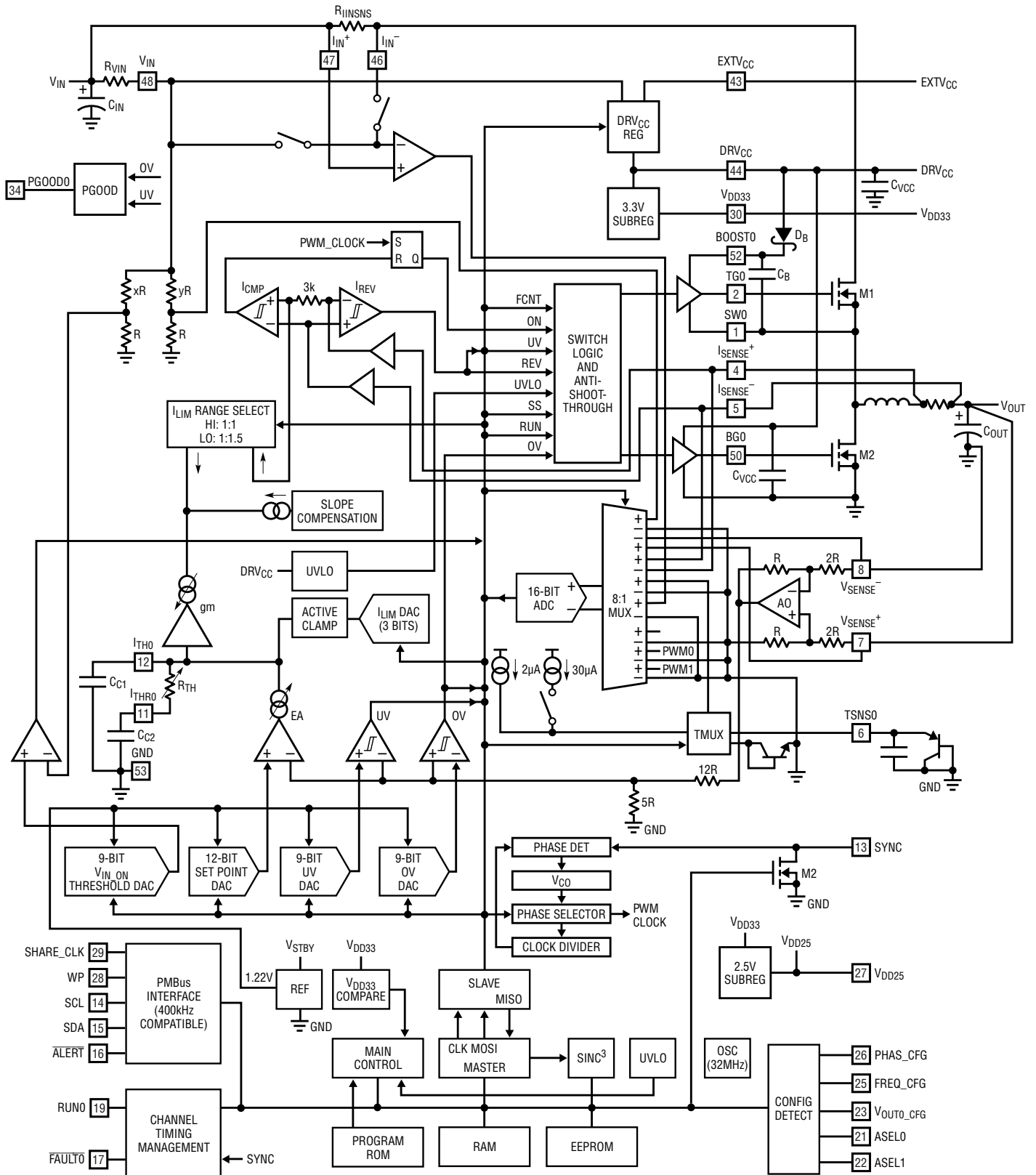

Figure 1. Block Diagram, One of Two Channels (CH0) Shown

OPERATION

OVERVIEW

The LTC3889 is a dual channel/dual phase, constant frequency, analog current mode controller for DC/DC step-down applications with a digital interface. The LTC3889 digital interface is compatible with PMBus which supports bus speeds of up to 400kHz. A typical application circuit is shown on the first page of this data sheet.

Major features include:

- Programmable Output Voltage
- Programmable Input Voltage Comparator
- Programmable Current Limit
- Programmable Switching Frequency
- Programmable OV and UV Comparators
- Programmable On and Off Delay Times
- Programmable Output Rise/Fall Times
- Programmable Loop Compensation
- Dedicated Power Good Pin for Each Channel
- Phase-Locked Loop for Synchronous, PolyPhase Operation (2, 3, 4 or 6 Phases)
- Input and Output Voltage/Current, and Temperature Telemetry
- Fully Differential Remote Sense on Channel 0
- Integrated Adjustable Gate Drivers
- Nonvolatile Configuration Memory with ECC
- Optional External Configuration Resistors for Key Operating Parameters
- Optional Time-Base Interconnect for Synchronization Between Multiple Controllers
- Fault Logging
- WP Pin to Protect Internal EEPROM Configuration
- Standalone Operation After User Factory Configuration
- PMBus Version 1.2, 400kHz Compliant Interface

The PMBus interface provides access to important power management data during system operation including:

- Internal Die Temperature
- External System Temperature via Optional Diode Sense Elements
- Average Output Current
- Average Output Voltage
- Average Input Voltage
- Average Input Current
- Configurable, Latched and Unlatched Individual Fault and Warning Status

Individual channels are accessed through the PMBus using the PAGE command, i.e., PAGE 0 or 1.

Fault reporting and shutdown behavior are fully configurable using the $\overline{\text{FAULT}}_n$ outputs. A dedicated pin for $\overline{\text{ALERT}}$ is provided. The shutdown operation also allows all faults to be individually masked and can be operated in either unlatched (retry) or latched modes.

Individual status commands enable fault reporting over the serial bus to identify the specific fault event. Fault or warning detection includes the following:

- Output Undervoltage/Overvoltage
- Input Undervoltage/Overvoltage
- Input and Output Overcurrent
- Internal Overtemperature
- External Overtemperature
- Communication, Memory or Logic (CML) Fault

MAIN CONTROL LOOP

The LTC3889 is a constant-frequency, current-mode step-down controller that operates at a user-defined relative phasing. During normal operation the top MOSFET is turned on when the clock for that channel sets the RS latch, and turned off when the main current comparator, I_{CMP} , resets the RS latch. The peak inductor current at which I_{CMP} resets the RS latch is controlled by the voltage on the

OPERATION

I_{TH} pin which is the output of the error amplifier, EA. The EA negative terminal is equal to the V_{SENSE} voltage divided by 34 (6.8 if range = 1). The positive terminal of the EA is connected to the output of a 12-bit DAC with values ranging from 0V to 1.22V. The output voltage, through feedback of the EA, will be regulated to 34 times the DAC output (6.8 if range = 1). The DAC value is calculated by the part to synthesize the users desired output voltage. The output voltage is programmed by the user either with the resistor configuration pins detailed in Table 3 or by the V_{OUT} command (either from EEPROM, or by PMBus command). Refer to the PMBus command section of the data sheet or the PMBus specification for more details. The output voltage can be modified by the user at any time with a PMBus $V_{OUT_COMMAND}$. This command will typically have a latency less than 10ms.

Continuing the basic operation description, the current mode controller will turn off the top gate when the peak current is reached. If the load current increases, V_{SENSE} will slightly droop with respect to the DAC reference. This causes the I_{TH} voltage to increase until the average inductor current matches the new load current. After the top MOSFET has turned off, the bottom MOSFET is turned on. In continuous conduction mode, the bottom MOSFET stays on until the end of the switching cycle.

EEPROM

The LTC3889 contains internal EEPROM with error correction coding (ECC) to store user configuration settings and fault log information. EEPROM endurance and retention for user space and fault log pages are specified in the Absolute Maximum Ratings and Electrical Characteristics table. The LTC3889 EEPROM also contains a manufacturing section that has internal redundancy.

The integrity of the entire onboard EEPROM is checked with a CRC calculation each time its data is to be read, such as after a power-on reset or execution of a $RESTORE_USER_ALL$ command. If a CRC error occurs, the CML bit is set in the $STATUS_BYTE$ and $STATUS_WORD$ commands, the EEPROM CRC Error bit in the $STATUS_MFR_SPECIFIC$ command is set, and the $ALERT$ and RUN pins pulled low (PWM channels off). At that point the device will respond

at special address 0x7C, which is activated only after an invalid CRC has been detected. The chip will also respond at the global addresses 0x5A and 0x5B, but use of these addresses when attempting to recover from a CRC issue is not recommended. All power supply rails associated with either PWM channel of a device reporting an invalid CRC should remain disabled until the issue is resolved. Contact the factory if EEPROM repair is unsuccessful.

ADI recommends that the EEPROM not be written when die temperature is greater than 85°C. If internal die temperature exceeds 130°C, all EEPROM operations except $RESTORE_USER_ALL$ and MFR_RESET are disabled. Full EEPROM operation is not re-enabled until die temperature falls below 125°C. Refer to the Applications Information section for equations to predict retention degradation due to elevated operating temperatures.

See the Applications Information section or contact the factory for details on efficient in-system EEPROM programming, including bulk EEPROM programming, which the LTC3889 also supports.

CRC Protection

The integrity of the EEPROM memory is checked after a power-on reset. A CRC error will prevent the controller from leaving the reset state. If a CRC error occurs, the CML bit is set in the $STATUS_BYTE$ and $STATUS_WORD$ commands, the appropriate bit is set in the $STATUS_MFR_SPECIFIC$ command, and the $ALERT$ pin will be pulled low. EEPROM repair can be attempted by writing the desired configuration to the controller and executing a $STORE_USER_ALL$ command followed by a $CLEAR_FAULTS$ command.

The LTC3889 protects the integrity of the manufacturing data and the user data by implementing ECC and CRC checks in the EEPROM. If the ECC cannot correct the contents of a single bit fault in the EEPROM, a CRC failure will occur. This assures that all double bit faults are detected. If the CRC checks fail in either the manufacturing or user data sections of the EEPROM, the "EEPROM CRC Fault" in the $STATUS_MFR_SPECIFIC$ command is set. If this bit remains set after being cleared by issuing a $CLEAR_FAULTS$ or writing a 1 to this bit, an irrecoverable fault has occurred. There are no provisions for field repair of the EEPROM for these types of faults.

OPERATION

POWER-UP AND INITIALIZATION

The LTC3889 is designed to provide standalone supply sequencing and controlled turn-on and turn-off operation. It can operate from a single V_{IN} input supply (6V to 60V) while two on-chip linear regulators generate internal 2.5V and 3.3V. If V_{IN} does not exceed 6V, and the $EXTV_{CC}$ pin is not driven by an external supply, the DRV_{CC} and V_{IN} pins must be tied together. The LTC3889 $EXTV_{CC}$ pin can be driven by an external supply to improve efficiency of the circuit and minimize power on the LTC3889. The $EXTV_{CC}$ pin must exceed approximately 5.3V (7.7V if $DRVSET = 1, 2$) before the DRV_{CC} voltage LDO operates from the $EXTV_{CC}$ pin. To minimize application power, the $EXTV_{CC}$ pin can be supplied by a switching regulator, or an output of the LTC3889. The $EXTV_{CC}$ pin voltage may exceed the V_{IN} pin voltage. The DRV_{CC} voltage LDO operates from the $EXTV_{CC}$ pin if the $EXTV_{CC}$ voltage exceeds the V_{IN} voltage by approximately 200mV. The controller configuration is initialized by an internal threshold based UVLO where V_{IN} must be approximately 4.2V and the 3.3V and 2.5V linear regulators must be within approximately 20% of the regulated values. A PMBus $RESTORE_USER_ALL$ or MFR_RESET command forces this same initialization.

During initialization, the external configuration resistors are identified and/or contents of the EEPROM are read into the controller's commands. The BGn , TGn , $PGOODn$ and $RUNn$ pins are held low. The \overline{FAULTn} pins are in high impedance mode. The LTC3889 will use the contents of Tables 3 to 6 to determine the resistor defined parameters. See the Resistor Configuration section for more detail. The resistor configuration pins only control some of the preset values of the controller. The remaining values are programmed in EEPROM either at the factory or by the user.

If the configuration resistors are not inserted or if the ignore $RCONFIG$ bit is asserted (bit 6 of the $MFR_CONFIG_ALL_LTC3889$ configuration command), the LTC3889 will use only the contents of EEPROM to determine the DC/DC characteristics. The $ASEL0$ and $ASEL1$ values read at power-up or reset are always respected unless the pins are open. See the Applications Information section for more detail.

After the part has initialized, an additional comparator monitors V_{IN} . The VIN_ON threshold must be exceeded before the output power sequencing can begin. After V_{IN} is initially applied, the part will typically require 35ms to initialize and begin the TON_DELAY timer. The read back of voltages and currents require an additional 0ms to 90ms.

SOFT-START

The part must enter the run state prior to soft-start. The RUN pin is released by the LTC3889 after the part initializes and V_{IN} is greater than the VIN_ON threshold. If multiple LTC3889s are used in an application, they all hold their respective run pins low until all devices initialize and V_{IN} exceeds the VIN_ON threshold for every device. The $SHARE_CLK$ pin assures all the devices connected to the signal use the same time base. The $SHARE_CLK$ pin is held low until the part has initialized after V_{IN} is applied and V_{IN} exceeds the VIN_ON threshold. The LTC3889 can be set to turn off (or remain off) if $SHARE_CLK$ is low (set bit 2 of $MFR_CHAN_CONFIG_LTC3889$ to a 1). This allows the user to assure synchronization across numerous ADI ICs even if the RUN pins can not be connected together due to board constraints. In general, if the user cares about synchronization between chips it is best to connect all the respective RUN pins together and to connect all the respective $SHARE_CLK$ pins together and pull up to V_{DD33} with a 5.49k resistor. This assures all chips begin sequencing at the same time and use the same time base.

After the $RUNn$ pin releases and prior to entering a constant output voltage regulation state, the LTC3889 performs a monotonic initial ramp or "soft-start". Soft-start is performed by actively regulating the load voltage while digitally ramping the target voltage from 0V to the commanded voltage set-point. Once the LTC3889 is commanded to turn on, (after power up and initialization) the controller waits for the user specified turn-on delay (TON_DELAY) prior to initiating this output voltage ramp. The rise time of the voltage ramp can be programmed using the TON_RISE command to minimize inrush currents associated with the start-up voltage ramp. The soft-start feature is disabled by setting the value of TON_RISE to any value less than 0.25ms. The LTC3889 PWM always

OPERATION

uses discontinuous mode during the TON_RISE operation. In discontinuous mode, the bottom gate is turned off as soon as reverse current is detected in the inductor. This will allow the regulator to start up into a pre-biased load. When the TON_MAX_FAULT_LIMIT is reached, the part transitions to continuous mode, if so programmed. If TON_MAX_FAULT_LIMIT is set to zero, there is no time limit and the part transitions to the desired conduction mode after TON_RISE completes and V_{OUT} has exceeded the VOUT_UV_FAULT_LIMIT and IOUT_OC is not present.

TIME-BASED SEQUENCING

The default mode for sequencing the output on and off is time based. The output is enabled after waiting TON_DELAY amount of time following either the RUN n pin going high, a PMBus command to turn on, or the V_{IN} pin voltage rising above a preprogrammed voltage. Off sequencing is handled in a similar way. To assure proper sequencing, make sure all ICs connect the SHARE_CLK pins together and RUN pins together. If the RUN pins can not be connected together for some reason, set bit 2 of MFR_CHAN_CONFIG_LTC3889 to a 1. This bit requires the SHARE_CLK pin to be clocking before the power supply output can start. When the RUN n pin is pulled low, the LTC3889 will hold the pin low for the MFR_RESTART_DELAY. The minimum MFR_RESTART_DELAY is TOFF_DELAY + TOFF_FALL + 136ms. This delay assures proper sequencing of all rails. The LTC3889 calculates this delay internally and will not process a shorter delay. However, a longer commanded MFR_RESTART_DELAY will be used by the part. The maximum allowed value is 65.52 seconds.

EVENT-BASED SEQUENCING

The PGOOD n pin is asserted when the output UV threshold is exceeded. It is possible to feed the PGOOD n pin from one LTC3889 into the RUN pin of the next LTC3889 in the sequence. This can be implemented across multiple LTC3889s. If a fault in the string of rails is detected, only the faulted rail and downstream rails will fault off. The rails in the string of devices in front of the faulted rail will remain on unless commanded off.

Event-Based Sequencing by Cascading PGOODs Into RUN Pins

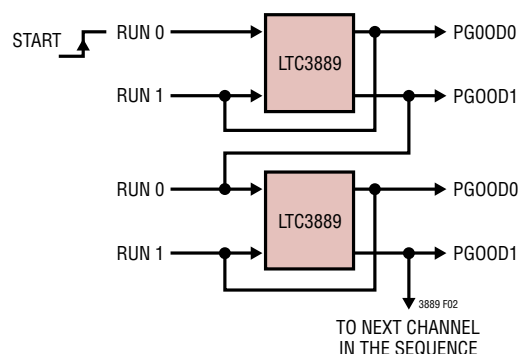

Figure 2. Event (Voltage) Based Sequencing

SHUTDOWN

The LTC3889 supports three shutdown modes. The first mode is continuous conduction mode, with user-defined turn-off delay (TOFF_DELAY) and ramp down rate (TOFF_FALL). The controller will draw current from the load to force TOFF_FALL. The second mode is discontinuous conduction mode. In discontinuous conduction mode the controller will not draw current from the load and the fall time will be set by the output capacitance and load current.

The third shutdown mode occurs in response to a fault condition or loss of SHARE_CLK (if bit 2 of MFR_CHAN_CONFIG_LTC3889 is set to a 1) or V_{IN} falling below the VIN_OFF threshold or FAULT n pulled low externally (if the MFR_FAULT_RESPONSE is set to inhibit). Under these conditions the power stage is disabled in order to stop the transfer of energy to the load as quickly as possible. The shutdown state can be entered from the soft-start or active regulation states.

In retry mode, the controller responds to a fault by shutting down and entering the inactive state for a programmable delay time (MFR_RETRY_DELAY). This delay minimizes the duty cycle associated with autonomous retries if the fault that caused the shutdown disappears once the output is disabled. The retry delay time is determined by the longer of the MFR_RETRY_DELAY command or the time required for the regulated output to decay below 12.5% of the programmed value. If multiple outputs are controlled by the same FAULT n pin, the decay time of the faulted output determines the retry delay. If the natural decay time

OPERATION

of the output is too long, it is possible to remove the voltage requirement of the MFR_RETRY_DELAY command by asserting bit 0 of MFR_CHAN_CONFIG_LTC3889. Alternatively, the controller can be configured so that it remains latched-off following a fault and re-enabling the outputs requires user intervention such as toggling RUN or commanding the part OFF then ON.

LIGHT-LOAD CURRENT OPERATION

The LTC3889 has two PWM modes of operation, discontinuous conduction mode or forced continuous conduction mode. Mode selection is done using the MFR_PWM_MODE_LTC3889 command (discontinuous conduction is always the start-up mode, forced continuous is the default running mode).

If a controller is enabled for discontinuous conduction operation, the inductor current is not allowed to reverse. The reverse current comparator, I_{REV} , turns off the bottom gate external MOSFET just before the inductor current reaches zero, preventing it from reversing and going negative. In forced continuous operation, the inductor current is allowed to reverse at light loads or under large transient conditions. The peak inductor current is determined solely by the voltage on the I_{TH} pin. In this mode, the efficiency at light loads is lower than in discontinuous conduction operation. However, continuous mode exhibits lower output ripple and less interference with audio circuitry. Forced continuous conduction mode may result in reverse inductor current, which can cause the input supply to boost. The VIN_OV_FAULT_LIMIT can detect this and turn off the offending channel. However, this fault is based on an ADC read and can take up to 90ms to detect. If there is a concern about the input supply boosting, keep the part in discontinuous conduction.

PWM LOOP COMPENSATION

The internal PWM loop compensation resistors R_{ITHn} of the LTC3889 can be adjusted using bit[4:0] of the MFR_PWM_COMP command.

The transconductance of the LTC3889 PWM error amplifier can be adjusted using bit[7:5] of the MFR_PWM_COMP command.

Refer to the Programmable Loop Compensation subsection in the Applications Information section for further details.

SWITCHING FREQUENCY AND PHASE

The switching frequency of the PWM can be established with an internal oscillator or an external time base. The internal phase-locked loop (PLL) synchronizes PWM control to this timing reference with proper phase relation, whether the clock is provided internally or externally. The device can also be configured to provide the master clock to other ICs through PMBus command, EEPROM setting, or external configuration resistors as outlined in Tables 4 and 5.

As clock master, the LTC3889 will drive its open-drain SYNC pin at the selected rate with a pulse width of 500ns. An external pull-up resistor between SYNC and V_{DD33} is required in this case. Only one device connected to SYNC should be designated to drive the pin. If multiple LTC3889s programmed as clock masters are wired to the same SYNC line with a pull-up resistor, just one of the devices is automatically elected to provide clocking, and the others disable their SYNC outputs.

The LTC3889 will automatically accept an external SYNC input, disabling its own SYNC drive if necessary. Whether configured to drive SYNC or not, the LTC3889 can continue PWM operation using its own internal oscillator if an external clock signal is subsequently lost. The device can also be programmed to always require an external oscillator for PWM operation by setting bit 4 of MFR_CONFIG_ALL_LTC3889. The status of the SYNC driver circuit is indicated by bit 10 of MFR_PADS.

The MFR_PWM_CONFIG_LTC3889 command can be used to configure the phase of each channel. Desired phase can also be set from EEPROM or external configuration resistors as outlined in Table 5. Designated phase is the relationship between the falling edge of SYNC and

OPERATION

the internal clock edge that sets the PWM latch to turn on the top power switch. Additional small propagation delays to the PWM control pins will also apply. Both channels must be off before the `FREQUENCY_SWITCH` and `MFR_PWM_CONFIG_LTC3889` commands can be written to the LTC3889.

The phase relationships and frequency are independent of each other, providing numerous application options. Multiple LTC3889 ICs can be synchronized to realize a PolyPhase array. In this case the phases should be separated by $360/n$ degrees, where n is the number of phases driving the output voltage rail.

OUTPUT VOLTAGE SENSING

The channel 0 differential amplifier allows remote, differential sensing of the load voltage with $V_{SENSE0n}$ pins in low range. In high range, the channel 0 sense pin (V_{SENSE0}) is referenced to GND. The channel 1 sense pin (V_{SENSE1}) is always referenced to GND. The (telemetry) ADC is fully differential and makes measurements of channels 0 and 1 output voltages at the $V_{SENSE0n}$ and V_{SENSE1}/GND pins, respectively. The maximum allowed differential sense voltage for V_{SENSE0}^+ to V_{SENSE0}^- is 40V.

OUTPUT CURRENT SENSING

For DCR current sense applications, a resistor in series with a capacitor is placed across the inductor. In this configuration, the resistor is tied to the FET side of the inductor while the capacitor is tied to the load side of the inductor as shown in Figure 3. If the RC values are chosen such that the RC time constant matches the inductor time constant (L/DCR , where DCR is the inductor series resistance), the resultant voltage (V_{DCR}) appearing across the capacitor will equal the voltage across the inductor series resistance and thus represent the current flowing through the inductor. The RC calculations are based on the room temperature DCR of the inductor.

The RC time constant should remain constant, as a function of temperature. This assures the transient response of the circuit is the same regardless of the temperature. The

DCR of the inductor has a large temperature coefficient, approximately 3900ppm/°C. The temperature coefficient of the inductor must be written to the `MFR_IOUT_CAL_GAIN_TC` command. The external temperature is sensed near the inductor and is used to modify the internal current limit circuit to maintain an essentially constant current limit with temperature. In this application, the I_{SENSE}^+ pin is connected to the FET side of the capacitor while the I_{SENSE}^- pin is placed on the load side of the capacitor. The current sensed from the input is then given by the expression V_{DCR}/DCR . V_{DCR} is digitized by the LTC3889's telemetry ADC with an input range of $\pm 100mV$, a noise floor of $7\mu V_{RMS}$, and a peak-peak noise of approximately 46.5 μV . The LTC3889 computes the inductor current using the DCR value stored in the `IOUT_CAL_GAIN` command and the temperature coefficient stored in command `MFR_IOUT_CAL_GAIN_TC`. The resulting current value is returned by the `READ_IOUT` command.

INPUT CURRENT SENSING

To sense the total input current consumed by the LTC3889 and the power stage, a resistor is placed between the supply voltage and the drain of the top N-channel MOSFET. The I_{IN}^+ and I_{IN}^- pins are connected to the sense resistor. The filtered voltage is amplified by the internal high side current sense amplifier and digitized by the LTC3889's telemetry ADC. The input current sense amplifier has three gain settings of 2x, 4x, and 8x set by the bit[6:5] of the `MFR_PWM_CONFIG_3889` command. The maximum differential input sense voltage for the three gain settings is 50mV, 20mV, and 5mV respectively. The LTC3889 computes the input current using the R value stored in the `IIN_CAL_GAIN` command. The resulting measured powerstage current is returned by the `READ_IIN` command.

The LTC3889 uses the `RVIN` resistor to measure the V_{IN} pin supply current being consumed by the LTC3889. This value is returned by the `MFR_READ_ICHIP` command. The chip current is calculated by using the R value stored in the `MFR_RVIN` command. Refer to the subsection titled Input Current Sense Amplifier in the Applications Information section for further detail.

OPERATION

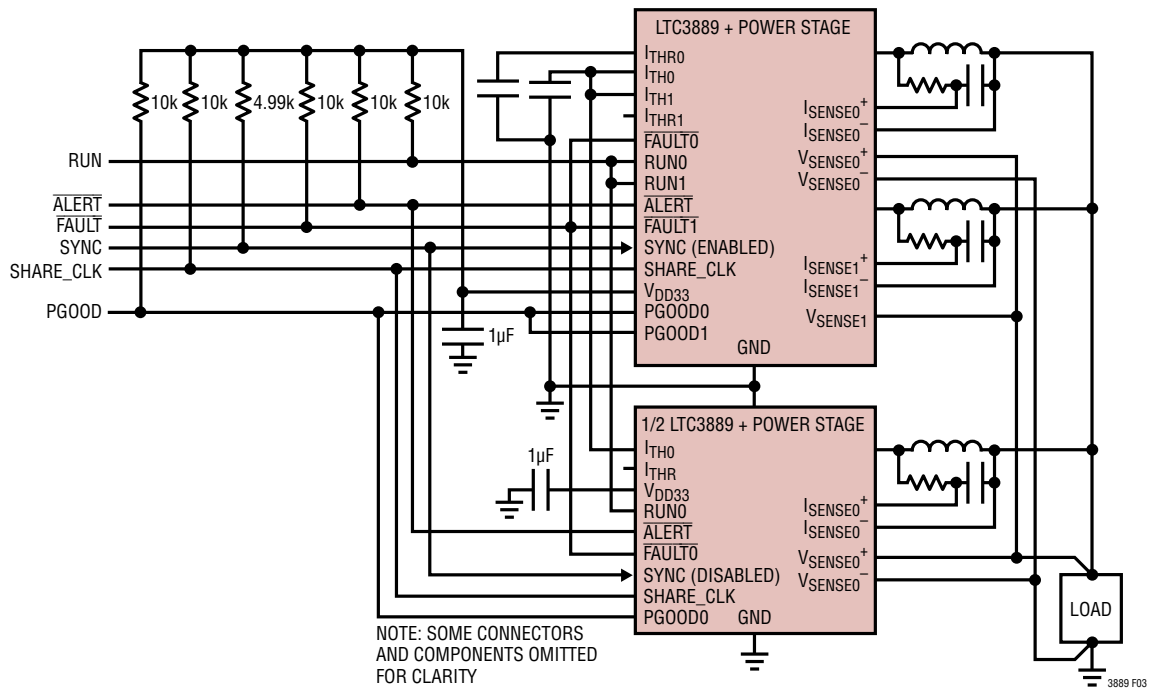

Figure 3. Load Sharing Connections for 3-Phase Operation

PolyPhase LOAD SHARING

Multiple LTC3889's can be connected in parallel in order to provide a balanced load-share solution by connecting the necessary pins. Figure 3 illustrates the shared connections required for load sharing.

The SYNC pin should only be enabled on one of the LTC3889s. The other(s) should be programmed to disable SYNC with the oscillator frequency set to the nominal value. When bit[7] of the MFR_PWM_CONFIG command is set, Channel 1 will use the feedback node of Channel 0 as its point of regulation. Do not assert bit[7] of MFR_PWM_CONFIG except in a PolyPhase application when both V_{OUT} pins are connected together and both I_{TH} pins are tied together.

EXTERNAL/INTERNAL TEMPERATURE SENSE

External temperature can best be measured using a remote, diode-connected PNP transistor such as the MMBT3906. The emitter should be connected to a TSNS pin while the base and collector terminals of the PNP transistor must be connected and returned directly to the Pin 53 of the

LTC3889 GND using a Kelvin connection. The bypass capacitor between the emitter and collector must be located near the transistor. Two different currents are applied to the diode (nominally $2\mu\text{A}$ and $32\mu\text{A}$) and the temperature is calculated from a ΔV_{BE} measurement made with the internal 16-bit ADC.

The LTC3889 also supports direct V_{BE} based external temperature measurements. In this case the diode or diode network is trimmed to a specific voltage at a specific current and temperature. In general this method does not yield as accurate of a result as the single PNP transistor, but may function better in noisy applications. Refer to MFR_PWM_MODE_LTC3889 in the PMBus Command Details section for additional information on programming the LTC3889 for these two external temperature sense configurations.

The calculated temperature is returned by the PMBus READ_TEMPERATURE_1 command. Refer to the Applications Information section for details on proper layout of external temperature sense elements and PMBus commands that can be used to improve the accuracy of calculated temperatures.

OPERATION

The READ_TEMPERATURE_2 command returns the internal junction temperature of the LTC3889 using an on-chip diode with a ΔV_{BE} measurement and calculation.

RCONFIG (RESISTOR CONFIGURATION) PINS

There are six input pins utilizing 1% resistor dividers between V_{DD25} and GND to select key operating parameters. The pins are ASELO, ASEL1, FREQ_CFG, V_{OUT0_CFG} , V_{OUT1_CFG} , PHAS_CFG. If pins are floated, the value stored in the corresponding EEPROM command is used. If bit 6 of the MFR_CONFIG_ALL_LTC3889 configuration command is asserted in EEPROM, the resistor inputs are ignored upon power-up except for ASELO and ASEL1 which are always respected. The resistor configuration pins are only measured during power-up and an execution of a RESTORE_USER_ALL or MFR_RESET command.

The V_{OUTn_CFG} pin settings are described in Table 3. These pins select the output voltages for the LTC3889's analog PWM controllers. If the pin is open, the VOUT_COMMAND command is loaded from EEPROM to determine the output voltage. The default setting is to have the switcher off unless the voltage configuration pins are installed.

The following parameters are set as a percentage of the output voltage if the RCONFIG pins are used to determined output voltage:

| | |
|-----------------------------|-------|
| ■ VOUT_OV_FAULT_LIMIT | +10% |
| ■ VOUT_OV_WARN_LIMIT | +7.5% |
| ■ VOUT_MAX..... | +7.5% |
| ■ VOUT_MARGIN_HIGH | +5% |
| ■ VOUT_MARGIN_LOW..... | -5% |
| ■ VOUT_UV_WARN_LIMIT | -6.5% |
| ■ VOUT_UV_FAULT_LIMIT..... | -7% |

The FREQ_CFG pin settings are described in Table 4. This pin selects the switching frequency. The phase relationships between the two channels and SYNC pin is determined by the PHAS_CFG pin described in Table 5. To synchronize to an external clock, the part should be put into external clock mode (SYNC output disabled but frequency set to the nominal value). If no external clock is supplied, the part will clock at the programmed frequency. If the application is multi-phase and the SYNC signal between chips is lost, the parts will not be at the same frequency

increasing the ripple voltage on the output, possibly producing undesirable operation. If the external SYNC signal is being generated internally and external SYNC is not selected, bit 10 of MFR_PADS will be asserted. If no frequency is selected and the external SYNC frequency is not present, a PLL_FAULT will occur. If the user does not wish to see the ALERT from a PLL_FAULT even if there is not a valid synchronization signal at power-up, the ALERT mask for PLL_FAULT must be written. See the description on SMBALERT_MASK for more details. If the SYNC pin is connected between multiple ICs only one of the ICs should have the SYNC pin enabled, all other ICs should be configured to SYNC pin disabled.

The ASELO and ASEL1 pin settings are described in Table 6. ASEL1 selects the top 3 bits of the slave address for the LTC3889. ASELO selects the bottom 4 bits of the slave address for the LTC3889. If ASEL1 is floating, the 3 most significant bits are retrieved from the EEPROM MFR_ADDRESS command. If ASELO is floating, the 4 LSB bits stored in EEPROM MFR_ADDRESS command are used to determine the 4 LSB bits of the slave address. For more detail, refer to Table 6.

Note: Per the PMBus specification, pin programmed parameters can be overridden by commands from the digital interface with the exception of the ASEL n pins which are always honored. Do not set any part address to 0x5A or 0x5B because these are global addresses and all parts will respond to them.

FAULT HANDLING

A variety of fault and warning reporting and handling mechanisms are available. Fault and warning detection capabilities include:

- Input OV/FAULT Protection and UV Warning
- Average Input OC Warn
- Output OV/UV Fault and Warn Protection
- Output OC Fault and Warn Protection
- Internal and External Overtemperature Fault and Warn Protection
- External Undertemperature Fault and Warn Protection

OPERATION

- CML Fault (Communication, Memory or Logic)
- External Fault Detection via the Bidirectional $\overline{\text{FAULT}}_n$ Pins.

In addition, the LTC3889 can map any combination of fault indicators to the $\overline{\text{FAULT}}_n$ pin using the propagate $\overline{\text{FAULT}}_n$ response commands, `MFR_FAULT_PROPAGATE_LTC3889`. Typical usage of the $\overline{\text{FAULT}}_n$ pin is as a driver for an external crowbar device, overtemperature alert, overvoltage alert or as an interrupt to cause a microcontroller to poll the fault commands. Alternatively, the $\overline{\text{FAULT}}_n$ pin can be used as an input to detect external faults downstream of the controller that require an immediate response.

As described in the Soft-Start section, it is possible to control start-up through concatenated events. If $\overline{\text{FAULT}}_n$ is used to drive the RUN pin of another controller, the unfiltered `VOUT_UV` fault limit should be mapped to the $\overline{\text{FAULT}}_n$ pin.

Any fault or warning event will cause the $\overline{\text{ALERT}}$ pin to assert low unless the fault or warning is masked by the `SMBALERT_MASK`. The pin will remain asserted low until the `CLEAR_FAULTS` command is issued, the fault bit is written to a 1, bias power is cycled or a `MFR_RESET` command is issued, the RUN pin is toggled OFF/ON, or the part is commanded OFF/ON via PMBus. The `MFR_FAULT_PROPAGATE_LTC3889` command determines if the $\overline{\text{FAULT}}_n$ pin is pulled low when a fault is detected.

Output and input fault event handling is controlled by the corresponding fault response byte as specified in Tables 7 to 11. Shutdown recovery from these types of faults can either be autonomous or latched. For autonomous recovery, the faults are not latched, so if the fault condition is not present after the retry interval has elapsed, a new soft-start is attempted. If the fault persists, the controller will continue to retry. The retry interval is specified by the `MFR_RETRY_DELAY` command and prevents damage to the regulator components by repetitive power cycling, assuming the fault condition itself is not immediately destructive. The `MFR_RETRY_DELAY` must be greater than 120ms. It can not exceed 83.88 seconds.

Status Registers and $\overline{\text{ALERT}}$ Masking

Figure 4 summarizes the internal LTC3889 status registers accessible by PMBus command. These contain

indication of various faults, warnings and other important operating conditions. As shown, the `STATUS_BYTE` and `STATUS_WORD` commands also summarize contents of other status registers. Refer to PMBus Command Details for specific information.

NONE OF THE ABOVE in `STATUS_BYTE` indicates that one or more of the bits in the most-significant nibble of `STATUS_WORD` are also set.

In general, any asserted bit in a `STATUS_x` register also pulls the $\overline{\text{ALERT}}$ pin low. Once set, $\overline{\text{ALERT}}$ will remain low until one of the following occurs.

- A `CLEAR_FAULTS`, `RESTORE_USER_ALL` or `MFR_RESET` Command Is Issued
- The Related Status Bit Is Written to a One
- The Faulted Channel Is Properly Commanded Off and Back On
- The LTC3889 Successfully Transmits Its Address During a PMBus ARA
- Bias Power Is Cycled

With some exceptions, the `SMBALERT_MASK` command can be used to prevent the LTC3889 from asserting $\overline{\text{ALERT}}$ for bits in these registers on a bit-by-bit basis. These mask settings apply to `STATUS_WORD` and `STATUS_BYTE` in the same fashion as the status bits themselves. For example, if $\overline{\text{ALERT}}$ is masked for all bits in Channel 0 `STATUS_VOUT`, then $\overline{\text{ALERT}}$ is effectively masked for the `VOUT` bit in `STATUS_WORD` for PAGE 0.

The `BUSY` bit in `STATUS_BYTE` also asserts $\overline{\text{ALERT}}$ low and cannot be masked. This bit can be set as a result of various internal interactions with PMBus communication. This fault occurs when a command is received that cannot be safely executed with one or both channels enabled. As discussed in Application Information, `BUSY` faults can be avoided by polling `MFR_COMMON` before executing some commands.

If masked faults occur immediately after power up, $\overline{\text{ALERT}}$ may still be pulled low because there has not been time to retrieve all of the programmed masking information from EEPROM.

OPERATION

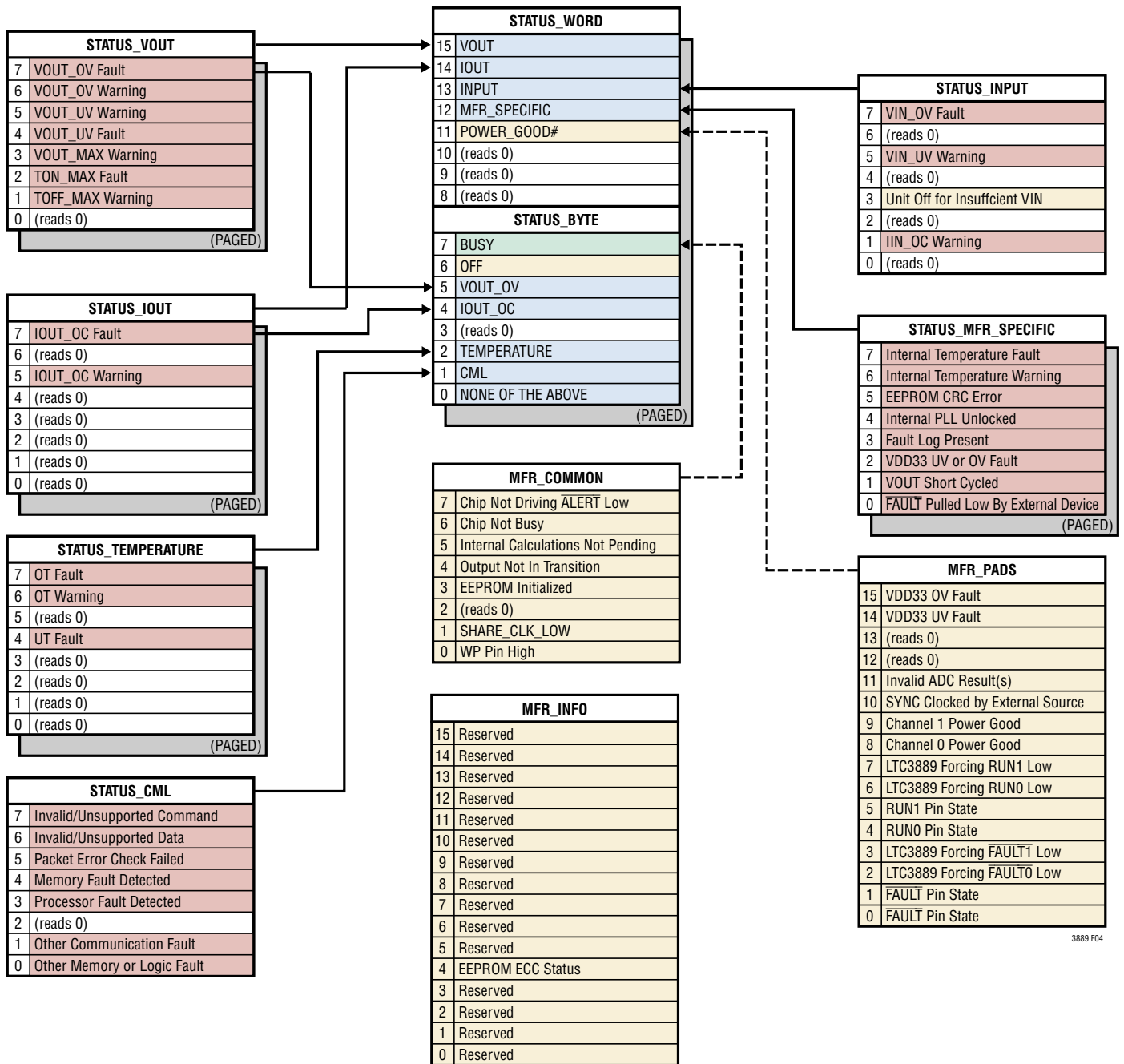

| DESCRIPTION | MASKABLE | GENERATES ALERT | BIT CLEARABLE |
|--------------------------------|----------|-----------------|---------------|
| General Fault or Warning Event | Yes | Yes | Yes |
| General Non-Maskable Event | No | Yes | Yes |
| Dynamic | No | No | No |
| Status Derived from Other Bits | No | Not Directly | No |

Figure 4. LTC3889 Status Register Summary

3889 F04

OPERATION

Status information contained in MFR_COMMON and MFR_PADS can be used to further debug or clarify the contents of STATUS_BYTE or STATUS_WORD as shown, but the contents of these registers do not affect the state of the $\overline{\text{ALERT}}$ pin and may not directly influence bits in STATUS_BYTE or STATUS_WORD.

Mapping Faults to $\overline{\text{FAULT}}$ Pins

The $\overline{\text{FAULT}}_n$ pins of the LTC3889 can share faults between channels and with all ADI PMBus products including the LTC3880, LTC2974, LTC2978, LTC4676 μ Module[®], etc. In the event of an internal fault, one or more of the LTC3889s is configured to pull the bussed $\overline{\text{FAULT}}_n$ pins low. The other LTC3889s are then configured to shut down when the $\overline{\text{FAULT}}_n$ pin bus is pulled low. For autonomous group retry, the faulted LTC3889 channel is configured to release the $\overline{\text{FAULT}}_n$ pin bus after a retry interval, assuming the original fault has cleared. All the channels in the group then begin a soft-start sequence. If the fault response is LATCH_OFF, the $\overline{\text{FAULT}}_n$ pin remains asserted low until either the RUN pin is toggled OFF/ON or the part is commanded OFF/ON. The toggling of the RUN either by the pin or OFF/ON command will clear faults associated with the LTC3889. If it is desired to have all faults cleared when either RUN pin is toggled, set bit 0 of MFR_CONFIG_ALL_LTC3889 to a 1.

The status of all faults and warnings is summarized in the STATUS_WORD and STATUS_BYTE commands.

Additional fault detection and handling capabilities are:

Power Good Pins

The PGOOD $_n$ pins of the LTC3889 are connected to the open drains of internal MOSFETs. The MOSFETs pull the PGOOD $_n$ pins low when the channel output voltage is not within the channels UV and OV voltage thresholds. During TON_DELAY and TON_RISE sequencing, the PG $_n$ pin is held low. The PGOOD $_n$ pin is also pulled low when the respective RUN $_n$ pin is low. The PGOOD $_n$ pin response is deglitched by an internal 60 μ s digital filter. The PGOOD $_n$ pin and PGOOD status may be different at times due to internal communication latency of up to 10 μ s.

SERIAL INTERFACE

The LTC3889 serial interface is a PMBus compliant slave device and can operate at any frequency between 10kHz and 400kHz. The address is configurable using either the EEPROM or an external resistor divider. In addition the LTC3889 always responds to the global broadcast address of 0x5A (7) or 0x5B (7).

The serial interface supports the following protocols defined in the PMBus specifications: 1) send command, 2) write byte, 3) write word, 4) group, 5) read byte, 6) read word, 7) read block, 8) write block, 9) PAGE_PLUS_READ, 10) PAGE_PLUS_WRITE, 11) SMBALERT_MASK read and 12) SMBALERT_MASK. All read operations will return a valid PEC if the PMBus master requests it. If the PEC_REQUIRED bit is set in the MFR_CONFIG_ALL_LTC3889 command, the PMBus write operations will not be acted upon until a valid PEC has been received by the LTC3889.

Communication Protection

PEC write errors (if PEC_REQUIRED is active), attempts to access unsupported commands, or writing invalid data to supported commands will result in a CML fault. The CML bit is set in the STATUS_BYTE and STATUS_WORD commands, the appropriate bit is set in the STATUS_CML command, and the $\overline{\text{ALERT}}$ pin is pulled low.

DEVICE ADDRESSING

The LTC3889 offers four different types of addressing over the PMBus interface, specifically: 1) global, 2) device, 3) rail addressing and 4) alert response address (ARA).

Global addressing provides a means of the PMBus master to address all LTC3889 devices on the bus. The LTC3889 global address is fixed 0x5A (7) or 0xB4 (8) and cannot be disabled. Commands sent to the global address act the same as if PAGE is set to a value of 0xFF. Commands sent are written to both channels simultaneously. Global command 0x5B (7) or 0xB6 (8) is paged and allows channel specific command of all LTC3889 devices on the bus. Other ADI device types may respond at one or both of these global addresses; therefore do not read from global addresses.

OPERATION

Rail addressing provides a means for the bus master to simultaneously communicate with all channels connected together to produce a single output voltage (PolyPhase). While similar to global addressing, the rail address can be dynamically assigned with the paged MFR_RAIL_ADDRESS command, allowing for any logical grouping of channels that might be required for reliable system control. Do not read from rail addresses since multiple ADI devices may respond.

Device addressing provides the standard means of the PMBus master communicating with a single instance of an LTC3889. The value of the device address is set by a combination of the ASEL0 and ASEL1 configuration pins and the MFR_ADDRESS command. Device addressing can be disabled by writing a value of 0x80 to the MFR_ADDRESS.

All four means of PMBus addressing require the user to employ disciplined planning to avoid addressing conflicts. Communication to LTC3889 devices at global and rail addresses should be limited to command write operations.

RESPONSES TO V_{OUT} AND I_{OUT} FAULTS

V_{OUT} OV and UV conditions are monitored by comparators. The OV and UV limits are set in three ways.

- As a Percentage of the V_{OUT} if Using the Resistor Configuration Pins
- In EEPROM if Either Programmed at the Factory or Through the GUI
- By PMBus Command

The I_{IN} and I_{OUT} overcurrent monitors are performed by ADC readings and calculations. Thus these values are based on average currents and can have a time latency of up to 120ms. The I_{OUT} calculation accounts for the sense resistor and the temperature coefficient of the resistor. The input current is equal to the voltage measured across the $R_{IINSENS}$ resistor divided by the resistors value as set with the MFR_RVIN command. If this calculated input current exceeds the IN_OC_WARN_LIMIT the ALERT pin

is pulled low and the IIN_OC_WARN bit is asserted in the STATUS_INPUT command.

The digital processor within the LTC3889 provides the ability to ignore the fault, shut down and latch off or shut down and retry indefinitely (retry). The retry interval is set in MFR_RETRY_DELAY and can be from 120ms to 83.88 seconds in 1ms increments. The shutdown for OV/UV and OC can be done immediately or after a user selectable deglitch time.

Output Overvoltage Fault Response

A programmable overvoltage comparator (OV) guards against transient overshoots as well as long-term overvoltages at the output. In such cases, the top MOSFET is turned off and the bottom MOSFET is turned on until the overvoltage condition is cleared *regardless of the PMBus VOUT_OV_FAULT_RESPONSE command byte value*. This hardware level fault response delay is typically 2 μ s from the overvoltage condition to BG asserted high. Using the VOUT_OV_FAULT_RESPONSE command, the user can select any of the following behaviors:

- OV Pull-Down Only (OV Cannot Be Ignored)
- Shut Down (Stop Switching) Immediately—Latch Off
- Shut Down Immediately—Retry Indefinitely Using the Time Interval Specified in MFR_RETRY_DELAY

Either the Latch Off or Retry fault responses can be deglitched in increments of (0-7) • 10 μ s. See Table 7.

Output Undervoltage Response

The response to an undervoltage comparator output can be either:

- Ignore
- Shut Down Immediately—Latch Off
- Shut Down Immediately—Retry Indefinitely Using the Time Interval Specified in MFR_RETRY_DELAY

The UV responses can be deglitched. See Table 8.

OPERATION

Peak Output Overcurrent Fault Response

Due to the current mode control algorithm, peak output current across the inductor is always limited on a cycle by cycle basis. The value of the peak current limit is specified in sense voltage in the EC table. The current limit circuit operates by limiting the I_{TH} maximum voltage. If DCR sensing is used, the I_{TH} maximum voltage has a temperature dependency directly proportional to the TC of the DCR of the inductor. The LTC3889 automatically monitors the external temperature sensors and modifies the maximum allowed I_{TH} to compensate for this term.

The overcurrent fault processing circuitry can execute the following behaviors:

- Current Limit Indefinitely
- Shut Down Immediately—Latch Off
- Shut Down Immediately—Retry Indefinitely Using the Time Interval Specified in MFR_RETRY_DELAY

The overcurrent responses can be deglitched in increments of (0-7) • 16ms. See Table 9.

RESPONSES TO TIMING FAULTS

TON_MAX_FAULT_LIMIT is the time allowed for V_{OUT} to rise and settle at start-up. The TON_MAX_FAULT_LIMIT condition is predicated upon detection of the VOUT_UV_FAULT_LIMIT as the output is undergoing a soft-start sequence. The TON_MAX_FAULT_LIMIT time is started after TON_DELAY has been reached and a soft-start sequence is started. The resolution of the TON_MAX_FAULT_LIMIT is 10 μ s. If the VOUT_UV_FAULT_LIMIT is not reached within the TON_MAX_FAULT_LIMIT time, the response of this fault is determined by the value of the TON_MAX_FAULT_RESPONSE command value. This response may be one of the following:

- Ignore
- Shut Down (Stop Switching) Immediately—Latch Off
- Shut Down Immediately—Retry Indefinitely at the Time Interval Specified in MFR_RETRY_DELAY

This fault response is not deglitched. A value of 0 in TON_MAX_FAULT_LIMIT means the fault is ignored. The TON_MAX_FAULT_LIMIT should be set longer than the TON_RISE time.

See Table 11.

RESPONSES TO V_{IN} OV FAULTS

V_{IN} overvoltage is measured with the ADC. The response is deglitched by the 90ms typical response time of the ADC. The fault responses are:

- Ignore
- Shut Down Immediately—Latch Off
- Shut Down Immediately—Retry Indefinitely Using the Time Interval Specified in MFR_RETRY_DELAY

See Table 11.

RESPONSES TO OT/UT FAULTS

Internal Overtemperature Fault/Warn Response

An internal temperature sensor protects against EEPROM damage. Above 85°C, no writes to EEPROM are recommended. Above 130°C, the internal overtemperature warn threshold is exceeded and the part will NACK any EEPROM related command except RESTORE_USER_ALL or MFR_RESET and issue a CML fault for Invalid/Unsupported Command. Full EEPROM operation is re-enabled when the internal temperature has dropped below 125°C. When the die temperature exceeds 160°C the internal overtemperature fault response is enabled and the PWM is disabled until the die temperature drops below 150°C. Temperature is measured by the ADC. Internal temperature faults cannot be ignored. Internal temperature limits cannot be adjusted by the user.

See Table 10.

OPERATION

External Overtemperature and Undertemperature Fault Response

An external temperature sensor can be used to sense critical circuit elements like the inductor and power MOSFETs. The OT_FAULT_RESPONSE and UT_FAULT_RESPONSE commands are used to determine the appropriate response to an overtemperature and undertemperature condition, respectively. If no external sense element is used (not recommended) set the UT_FAULT_RESPONSE to ignore and set the UT_FAULT_LIMIT to -275°C . However, not using an external temperature sense element is not recommended.

The fault responses are:

- Ignore
- Shut Down Immediately—Latch Off
- Shut Down Immediately—Retry Indefinitely Using the Time Interval Specified in MFR_RETRY_DELAY

See Table 11.

RESPONSES TO EXTERNAL FAULTS

When either $\overline{\text{FAULT}}_n$ pin is pulled low, the respective $\overline{\text{FAULT}}_n$ bit is deasserted in the MFR_PADS command, the $\overline{\text{FAULT}}_n$ bit is set in the STATUS_MFR_SPECIFIC command, the NONE_OF_THE_ABOVE bit is set in the STATUS_BYTE command, and the $\overline{\text{ALERT}}$ pin is pulled low. Responses are not deglitched. Each channel can be configured to ignore or shut down then retry in response to its $\overline{\text{FAULT}}_n$ pin going low by modifying the MFR_FAULT_RESPONSE command. To avoid the $\overline{\text{ALERT}}$ pin asserting low when $\overline{\text{FAULT}}$ is pulled low, assert bit 1 of MFR_CHAN_CONFIG_LTC3889, or mask the $\overline{\text{ALERT}}$ using the SMBALERT_MASK command.

FAULT LOGGING

The LTC3889 has fault logging capability. Data is logged into memory in the order shown in Table 13. The data is stored in a continuously updated buffer in RAM. When a fault event occurs, the fault log buffer is copied from the RAM buffer into EEPROM. Fault logging is allowed at temperatures above 85°C ; however, retention of 10 years is not guaranteed. When the die temperature exceeds 130°C ,

the fault logging is delayed until the die temperature drops below 125°C . The fault log data remains in EEPROM until a MFR_FAULT_LOG_CLEAR command is issued. Issuing this command re-enables the fault log feature. Before re-enabling fault log, be sure no faults are present and a CLEAR_FAULTS command has been issued.

When the LTC3889 powers-up or exits reset state, it checks the EEPROM for a valid fault log. If a valid fault log exists in EEPROM, the “Valid Fault Log” bit in the STATUS_MFR_SPECIFIC command will be set and an $\overline{\text{ALERT}}$ event will be generated. Also, fault logging will be blocked until the LTC3889 has received a MFR_FAULT_LOG_CLEAR command before fault logging will be re-enabled.

The information is stored in EEPROM in the event of any fault that disables the controller. The $\overline{\text{FAULT}}_n$ pin being externally pulled low will not trigger a fault logging event.

BUS TIMEOUT PROTECTION

The LTC3889 implements a timeout feature to avoid persistent faults on the serial interface. The data packet timer begins at the first START event before the device address write byte. Data packet information must be completed within 30ms or the LTC3889 will three-state the bus and ignore the given data packet. If more time is required, assert bit 3 of MFR_CONFIG_ALL_LTC3889 to allow typical bus timeouts of 255ms. Data packet information includes the device address byte write, command byte, repeat start event (if a read operation), device address byte read (if a read operation), all data bytes and the PEC byte if applicable.

The LTC3889 allows for PMBus timeouts proportional to the length of the block read data packets. The part will add 1ms for every byte of length in excess of 32 bytes. The additional block read timeout applies primarily to the MFR_FAULT_LOG command. The timeout period defaults to 30ms.

The user is encouraged to use as high a clock rate as possible to maintain efficient data packet transfer between all devices sharing the serial bus interface. The LTC3889 supports the full PMBus frequency range from 10kHz to 400kHz.

OPERATION

SIMILARITY BETWEEN PMBus, SMBus AND I²C 2-WIRE INTERFACE

The PMBus 2-wire interface is an incremental extension of the SMBus. SMBus is built upon I²C with some minor differences in timing, DC parameters and protocol. The PMBus/SMBus protocols are more robust than simple I²C byte commands because PMBus/SMBus provide timeouts to prevent persistent bus errors and optional packet error checking (PEC) to ensure data integrity. In general, a master device that can be configured for I²C communication can be used for PMBus communication with little or no change to hardware or firmware. Repeat start (restart) is not supported by all I²C controllers but is required for SMBus/PMBus reads. If a general purpose I²C controller is used, check that repeat start is supported.

The LTC3889 supports the maximum SMBus clock speed of 100kHz and is compatible with the higher speed PMBus specification (between 100kHz and 400kHz) if MFR_COMMON polling or clock stretching is enabled. For robust communication and operation refer to the Note section in the PMBus Command Summary. Clock stretching is enabled by asserting bit 1 of MFR_CONFIG_ALL_LTC3889.

For a description of the minor extensions and exceptions PMBus makes to SMBus, refer to PMBus Specification Part 1 Revision 1.1: Paragraph 5: Transport.

For a description of the differences between SMBus and I²C, refer to System Management Bus (SMBus) Specification Version 2.0: Appendix B—Differences Between SMBus and I²C.

PMBus SERIAL DIGITAL INTERFACE

The LTC3889 communicates with a host (master) using the standard PMBus serial bus interface. The Timing Diagram, Figure 5, shows the timing relationship of the signals on the bus. The two bus lines, SDA and SCL, must be high when the bus is not in use. External pull-up resistors or current sources are required on these lines.

The LTC3889 is a slave device. The master can communicate with the LTC3889 using the following formats:

- Master transmitter, slave receiver
- Master receiver, slave transmitter

The following PMBus protocols are supported:

- Write Byte, Write Word, Send Byte
- Read Byte, Read Word, Block Read, Block Write
- Alert Response Address

Figures 6-23 illustrate the aforementioned PMBus protocols. All transactions support PEC (parity error check) and GCP (group command protocol). The Block Read supports 255 bytes of returned data. For this reason, the PMBus timeout may be extended when reading the fault log.

Figure 6 is a key to the protocol diagrams in this section. PEC is optional.

A value shown below a field in the following figures is a mandatory value for that field.

The data formats implemented by PMBus are:

- Master transmitter transmits to slave receiver. The transfer direction in this case is not changed.
- Master reads slave immediately after the first byte. At the moment of the first acknowledgment (provided by the slave receiver) the master transmitter becomes a master receiver and the slave receiver becomes a slave transmitter.
- Combined format. During a change of direction within a transfer, the master repeats both a start condition and the slave address but with the R/W bit reversed. In this case, the master receiver terminates the transfer by generating a NACK on the last byte of the transfer and a STOP condition.

Refer to Figure 6 for a legend.

Handshaking features are included to ensure robust system communication. Please refer to the PMBus Communication and Command Processing subsection of the Applications Information section for further details.

OPERATION

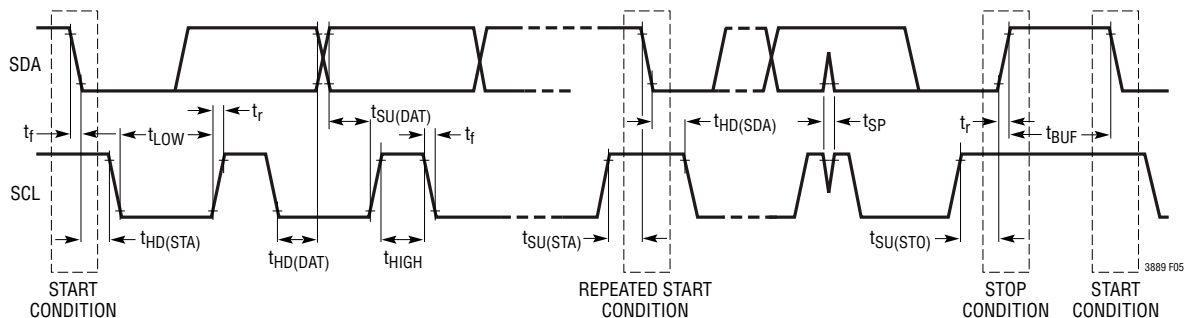

Figure 5. Timing Diagram

Table 1. Abbreviations of Supported Data Formats

| | PMBus | | ADI TERMINOLOGY | DEFINITION | EXAMPLE |
|-----|------------------|-------------------------|-----------------|---|---|
| | TERMINOLOGY | SPECIFICATION REFERENCE | | | |
| L11 | Linear | Part II ¶7.1 | Linear_5s_11s | Floating point 16-bit data: value = $Y \cdot 2^N$, where $N = b[15:11]$ and $Y = b[10:0]$, both two's complement binary integers. | $b[15:0] = 0x9807 = 10011_000_0000_0111$ value = $7 \cdot 2^{-13} = 854E-6$ |
| L16 | Linear VOUT_MODE | Part II ¶8.2 | Linear_16u | Floating point 16-bit data: value = $Y \cdot 2^{-10}$, where $Y = b[15:0]$, an unsigned integer. | $b[15:0] = 0x4C00 = 0100_1100_0000_0000$ value = $19456 \cdot 2^{-10} = 19$ |
| CF | DIRECT | Part II ¶7.2 | Varies | 16-bit data with a custom format defined in the detailed PMBus command description. | Often an unsigned or two's complement integer. |
| Reg | register bits | Part II ¶10.3 | Reg | Per-bit meaning defined in detailed PMBus command description. | PMBus STATUS_BYTE command. |
| ASC | text characters | Part II ¶22.2.1 | ASCII | ISO/IEC 8859-1 [A05] | LTC (0x4C5443) |

OPERATION

- S START CONDITION
- Sr REPEATED START CONDITION
- Rd READ (BIT VALUE OF 1)
- Wr WRITE (BIT VALUE OF 0)
- A ACKNOWLEDGE (THIS BIT POSITION MAY BE 0 FOR AN ACK OR 1 FOR A NACK)
- P STOP CONDITION
- PEC PACKET ERROR CODE
- MASTER TO SLAVE
- SLAVE TO MASTER
- ... CONTINUATION OF PROTOCOL

3889 F06

Figure 6. PMBus Packet Protocol Diagram Element Key

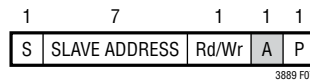

Figure 7. Quick Command Protocol

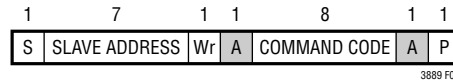

Figure 8. Send Byte Protocol

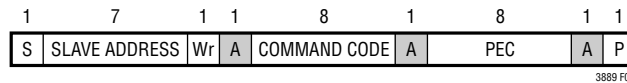

Figure 9. Send Byte Protocol with PEC

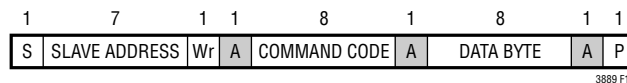

Figure 10. Write Byte Protocol

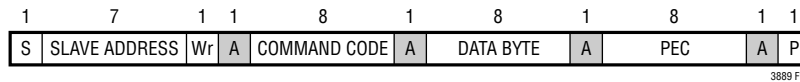

Figure 11. Write Byte Protocol with PEC

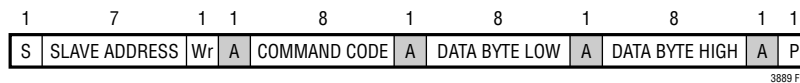

Figure 12. Write Word Protocol

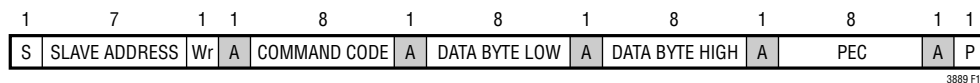

Figure 13. Write Word Protocol with PEC

OPERATION

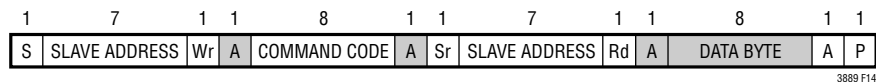

Figure 14. Read Byte Protocol

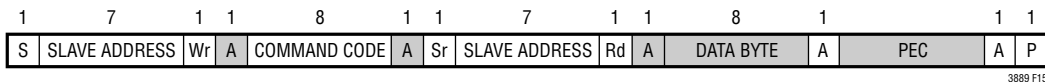

Figure 15. Read Byte Protocol with PEC

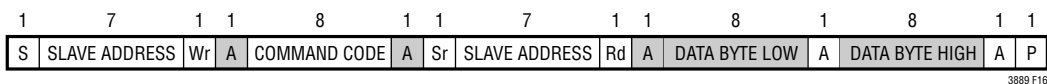

Figure 16. Read Word Protocol

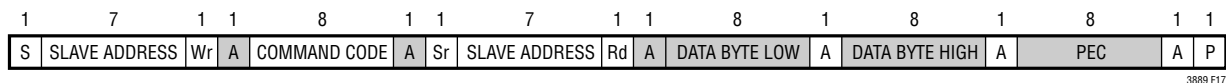

Figure 17. Read Word Protocol with PEC

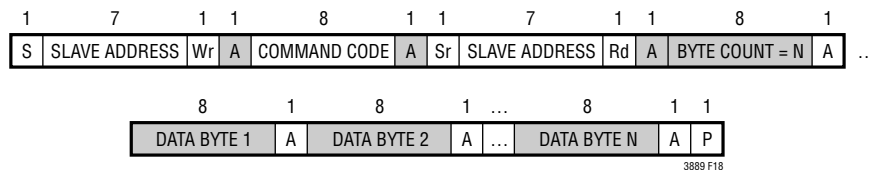

Figure 18. Block Read Protocol

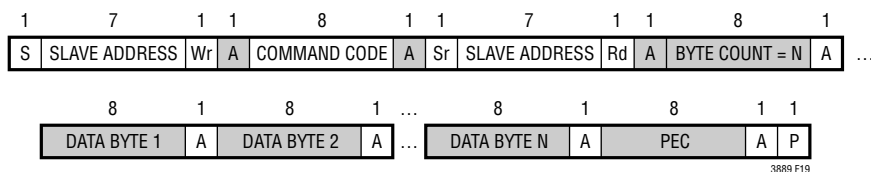

Figure 19. Block Read Protocol with PEC

OPERATION

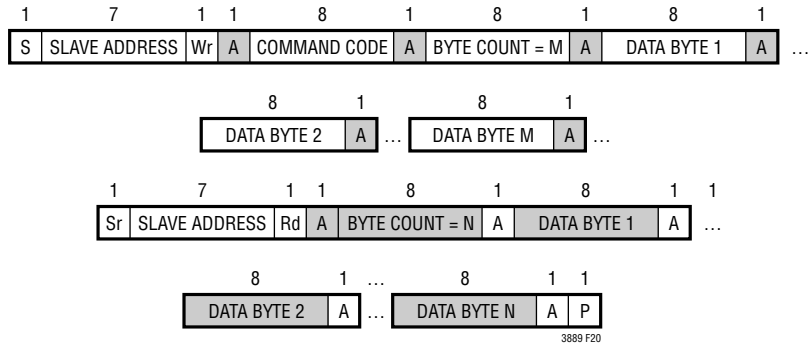

Figure 20. Block Write – Block Read Process Call

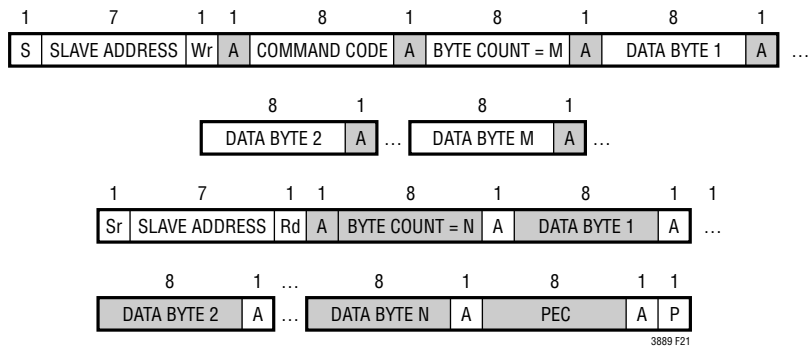

Figure 21. Block Write – Block Read Process Call with PEC

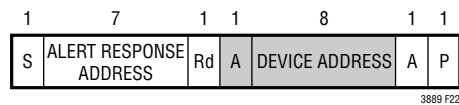

Figure 22. Alert Response Address Protocol

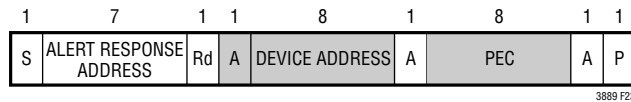

Figure 23. Alert Response Address Protocol with PEC

PMBus COMMAND SUMMARY

PMBus COMMANDS

The following tables list supported PMBus commands and manufacturer specific commands. A complete description of these commands can be found in the PMBus Power System Mgt Protocol Specification. Users are encouraged to reference this specification. Exceptions or manufacturer specific implementations are listed below in Table 2. Floating point values listed in the “DEFAULT VALUE” column are either Linear 16-bit Signed (PMBus Section 8.3.1) or Linear_5s_11s (PMBus Section 7.1) format, whichever is appropriate for the command. All commands from 0xD0 through 0xFF not listed in this table are implicitly reserved by the manufacturer. Users should avoid blind writes within this range of commands to avoid undesired operation of the part. All commands from 0x00 through 0xCF not listed in this table are

implicitly not supported by the manufacturer. Attempting to access non-supported or reserved commands may result in a CML command fault event. All output voltage settings and measurements are based on the VOUT_MODE setting of 0x16. This translates to an exponent of 2^{-10} .

If PMBus commands are received faster than they are being processed, the part may become too busy to handle new commands. In these circumstances the part follows the protocols defined in the PMBus Specification v1.1, Part II, Section 10.8.7, to communicate that it is busy. The part includes handshaking features to eliminate busy errors and simplify error handling software while ensuring robust communication and system behavior. Please refer to the subsection titled PMBus Communication and Command Processing in the Applications Information section for further details.

Table 2. Summary (Note: The Data Format abbreviations are detailed at the end of this table.)

| COMMAND NAME | CMD CODE | DESCRIPTION | TYPE | PAGED | DATA FORMAT | UNITS | EEPROM | DEFAULT VALUE | PAGE |
|------------------|----------|---|-----------|-------|-------------|-------|--------|-------------------|---------------------|
| PAGE | 0x00 | Provides integration with multi-page PMBus devices. | R/W Byte | N | Reg | | | 0x00 | 67 |
| OPERATION | 0x01 | Operating mode control. On/off, margin high and margin low. | R/W Byte | Y | Reg | | Y | 0x40 | 71 |
| ON_OFF_CONFIG | 0x02 | RUN pin and PMBus bus on/off command configuration. | R/W Byte | Y | Reg | | Y | 0x1E | 71 |
| CLEAR_FAULTS | 0x03 | Clear any fault bits that have been set. | Send Byte | N | | | | NA | 98 |
| PAGE_PLUS_WRITE | 0x05 | Write a command directly to a specified page. | W Block | N | | | | | 67 |
| PAGE_PLUS_READ | 0x06 | Read a command directly from a specified page. | Block R/W | N | | | | | 68 |
| WRITE_PROTECT | 0x10 | Level of protection provided by the device against accidental changes. | R/W Byte | N | Reg | | Y | 0x00 | 68 |
| STORE_USER_ALL | 0x15 | Store user operating memory to EEPROM. | Send Byte | N | | | | NA | 109 |
| RESTORE_USER_ALL | 0x16 | Restore user operating memory from EEPROM. | Send Byte | N | | | | NA | 109 |
| CAPABILITY | 0x19 | Summary of PMBus optional communication protocols supported by this device. | R Byte | N | Reg | | | 0xB0 | 97 |
| SMBALERT_MASK | 0x1B | Mask ALERT activity | Block R/W | Y | Reg | | Y | see CMD | 99 |
| VOUT_MODE | 0x20 | Output voltage format and exponent. | R Byte | Y | Reg | | | 2^{-10} 0x16 | 77 |
| VOUT_COMMAND | 0x21 | Nominal output voltage set point. | R/W Word | Y | L16 | V | Y | 5.0 0x1400 | 79 |
| VOUT_MAX | 0x24 | Upper limit on the commanded output voltage including VOUT_MARGIN_HI. | R/W Word | Y | L16 | V | Y | 40.0 0xA000 | 77 |
| VOUT_MARGIN_HIGH | 0x25 | Margin high output voltage set point. Must be greater than VOUT_COMMAND. | R/W Word | Y | L16 | V | Y | 5.25 0x1500 | 78 |

PMBus COMMAND SUMMARY

| COMMAND NAME | CMD CODE | DESCRIPTION | TYPE | PAGED | DATA FORMAT | UNITS | EEPROM | DEFAULT VALUE | PAGE |
|------------------------|----------|---|----------|-------|-------------|-------|--------|-----------------|--------------------|
| VOUT_MARGIN_LOW | 0x26 | Margin low output voltage set point. Must be less than VOUT_COMMAND. | R/W Word | Y | L16 | V | Y | 4.75 0x1300 | 79 |
| VOUT_TRANSITION_RATE | 0x27 | Rate the output changes when VOUT commanded to a new value. | R/W Word | Y | L11 | V/ms | Y | 0.25 0xAA00 | 85 |
| FREQUENCY_SWITCH | 0x33 | Switching frequency of the controller. | R/W Word | N | L11 | kHz | Y | 250 0xF3E8 | 75 |
| VIN_ON | 0x35 | Input voltage at which the unit should start power conversion. | R/W Word | N | L11 | V | Y | 6.5 0xCB40 | 76 |
| VIN_OFF | 0x36 | Input voltage at which the unit should stop power conversion. | R/W Word | N | L11 | V | Y | 6.0 0xCB00 | 76 |
| IOUT_CAL_GAIN | 0x38 | The ratio of the voltage at the current sense pins to the sensed current. For devices using a fixed current sense resistor, it is the resistance value in mΩ. | R/W Word | Y | L11 | mΩ | Y | 1.8 0xBB9A | 80 |
| VOUT_OV_FAULT_LIMIT | 0x40 | Output overvoltage fault limit. | R/W Word | Y | L16 | V | Y | 5.5 0x1600 | 78 |
| VOUT_OV_FAULT_RESPONSE | 0x41 | Action to be taken by the device when an output overvoltage fault is detected. | R/W Byte | Y | Reg | | Y | 0xB8 | 88 |
| VOUT_OV_WARN_LIMIT | 0x42 | Output overvoltage warning limit. | R/W Word | Y | L16 | V | Y | 5.375 0x1580 | 78 |
| VOUT_UV_WARN_LIMIT | 0x43 | Output undervoltage warning limit. | R/W Word | Y | L16 | V | Y | 4.625 1280 | 79 |
| VOUT_UV_FAULT_LIMIT | 0x44 | Output undervoltage fault limit. | R/W Word | Y | L16 | V | Y | 4.5 0x1200 | 79 |
| VOUT_UV_FAULT_RESPONSE | 0x45 | Action to be taken by the device when an output undervoltage fault is detected. | R/W Byte | Y | Reg | | Y | 0xB8 | 89 |
| IOUT_OC_FAULT_LIMIT | 0x46 | Output overcurrent fault limit. | R/W Word | Y | L11 | A | Y | 29.75 0xDBB8 | 81 |
| IOUT_OC_FAULT_RESPONSE | 0x47 | Action to be taken by the device when an output overcurrent fault is detected. | R/W Byte | Y | Reg | | Y | 0x00 | 91 |
| IOUT_OC_WARN_LIMIT | 0x4A | Output overcurrent warning limit. | R/W Word | Y | L11 | A | Y | 20.0 0xDA80 | 82 |
| OT_FAULT_LIMIT | 0x4F | External overtemperature fault limit. | R/W Word | Y | L11 | C | Y | 100.0 0xEB20 | 83 |
| OT_FAULT_RESPONSE | 0x50 | Action to be taken by the device when an external overtemperature fault is detected, | R/W Byte | Y | Reg | | Y | 0xB8 | 93 |
| OT_WARN_LIMIT | 0x51 | External overtemperature warning limit. | R/W Word | Y | L11 | C | Y | 85.0 0xEAA8 | 84 |
| UT_FAULT_LIMIT | 0x53 | External undertemperature fault limit. | R/W Word | Y | L11 | C | Y | -40.0 0xE580 | 84 |
| UT_FAULT_RESPONSE | 0x54 | Action to be taken by the device when an external undertemperature fault is detected. | R/W Byte | Y | Reg | | Y | 0xB8 | 93 |
| VIN_OV_FAULT_LIMIT | 0x55 | Input supply overvoltage fault limit. | R/W Word | N | L11 | V | Y | 48.0 0xE300 | 76 |
| VIN_OV_FAULT_RESPONSE | 0x56 | Action to be taken by the device when an input overvoltage fault is detected. | R/W Byte | Y | Reg | | Y | 0x80 | 87 |
| VIN_UV_WARN_LIMIT | 0x58 | Input supply undervoltage warning limit. | R/W Word | N | L11 | V | Y | 6.3 0xCB26 | 76 |
| IIN_OC_WARN_LIMIT | 0x5D | Input supply overcurrent warning limit. | R/W Word | N | L11 | A | Y | 10.0 0xD280 | 82 |

PMBus COMMAND SUMMARY

| COMMAND NAME | CMD CODE | DESCRIPTION | TYPE | PAGED | DATA FORMAT | UNITS | EEPROM | DEFAULT VALUE | PAGE |
|------------------------|----------|--|----------|-------|-------------|-------|--------|-----------------|---------------------|
| TON_DELAY | 0x60 | Time from RUN and/or Operation on to output rail turn-on. | R/W Word | Y | L11 | ms | Y | 0.0 0x8000 | 84 |
| TON_RISE | 0x61 | Time from when the output starts to rise until the output voltage reaches the VOUT commanded value. | R/W Word | Y | L11 | ms | Y | 8.0 0xD200 | 85 |
| TON_MAX_FAULT_LIMIT | 0x62 | Maximum time from the start of TON_RISE for VOUT to cross the VOUT_UV_FAULT_LIMIT. | R/W Word | Y | L11 | ms | Y | 10.00 0xD280 | 85 |
| TON_MAX_FAULT_RESPONSE | 0x63 | Action to be taken by the device when a TON_MAX_FAULT event is detected. | R/W Byte | Y | Reg | | Y | 0xB8 | 90 |
| TOFF_DELAY | 0x64 | Time from RUN and/or Operation off to the start of TOFF_FALL ramp. | R/W Word | Y | L11 | ms | Y | 0.0 0x8000 | 85 |
| TOFF_FALL | 0x65 | Time from when the output starts to fall until the output reaches zero volts. | R/W Word | Y | L11 | ms | Y | 8.00 0xD200 | 86 |
| TOFF_MAX_WARN_LIMIT | 0x66 | Maximum allowed time, after TOFF_FALL completed, for the unit to decay below 12.5%. | R/W Word | Y | L11 | ms | Y | 150.0 0xF258 | 86 |
| STATUS_BYTE | 0x78 | One byte summary of the unit's fault condition. | R/W Byte | Y | Reg | | | NA | 100 |
| STATUS_WORD | 0x79 | Two byte summary of the unit's fault condition. | R/W Word | Y | Reg | | | NA | 100 |
| STATUS_VOUT | 0x7A | Output voltage fault and warning status. | R/W Byte | Y | Reg | | | NA | 101 |
| STATUS_IOUT | 0x7B | Output current fault and warning status. | R/W Byte | Y | Reg | | | NA | 101 |
| STATUS_INPUT | 0x7C | Input supply fault and warning status. | R/W Byte | N | Reg | | | NA | 102 |
| STATUS_TEMPERATURE | 0x7D | External temperature fault and warning status for READ_TEMPERATURE_1. | R/W Byte | Y | Reg | | | NA | 102 |
| STATUS_CML | 0x7E | Communication and memory fault and warning status. | R/W Byte | N | Reg | | | NA | 103 |
| STATUS_MFR_SPECIFIC | 0x80 | Manufacturer specific fault and state information. | R/W Byte | Y | Reg | | | NA | 103 |
| READ_VIN | 0x88 | Measured input supply voltage. | R Word | N | L11 | V | | NA | 105 |
| READ_IIN | 0x89 | Measured input supply current. | R Word | N | L11 | A | | NA | 106 |
| READ_VOUT | 0x8B | Measured output voltage. | R Word | Y | L16 | V | | NA | 106 |
| READ_IOUT | 0x8C | Measured output current. | R Word | Y | L11 | A | | NA | 106 |
| READ_TEMPERATURE_1 | 0x8D | External temperature sensor temperature. This is the value used for all temperature related processing, including IOUT_CAL_GAIN. | R Word | Y | L11 | C | | NA | 106 |
| READ_TEMPERATURE_2 | 0x8E | Internal die junction temperature. Does not affect any other commands. | R Word | N | L11 | C | | NA | 106 |
| READ_FREQUENCY | 0x95 | Measured PWM switching frequency. | R Word | Y | L11 | kHz | | NA | 106 |
| READ_POUT | 0x96 | Calculated output power. | R Word | Y | L11 | W | | NA | 106 |
| READ_PIN | 0x97 | Calculated input power | R Word | N | L11 | W | | NA | 107 |
| PMBUS_REVISION | 0x98 | PMBus revision supported by this device. Current revision is 1.2. | R Byte | N | Reg | | | 0x22 | 97 |
| MFR_ID | 0x99 | The manufacturer ID of the LTC3889 in ASCII. | R String | N | ASC | | | LTC | 97 |
| MFR_MODEL | 0x9A | Manufacturer part number in ASCII. | R String | N | ASC | | | LTC3889 | 97 |
| MFR_VOUT_MAX | 0xA5 | Maximum allowed output voltage including VOUT_OV_FAULT_LIMIT. | R Word | Y | L16 | V | | 40.5 0xA200 | 80 |

PMBus COMMAND SUMMARY

| COMMAND NAME | CMD CODE | DESCRIPTION | TYPE | PAGED | DATA FORMAT | UNITS | EEPROM | DEFAULT VALUE | PAGE |
|-----------------------------|----------|---|-----------|-------|-------------|-------|--------|-----------------|---------------------|
| IC_DEVICE_ID | 0xAD | Identification of the IC | R Block | N | Reg | | Y | LTC3889 | 97 |
| IC_DEVICE_REV | 0xAE | Revision of the IC | R Block | N | Reg | | Y | ACA1 | 98 |
| USER_DATA_00 | 0xB0 | OEM RESERVED. Typically used for part serialization. | R/W Word | N | Reg | | Y | NA | 96 |
| USER_DATA_01 | 0xB1 | Manufacturer reserved for LTpowerPlay. | R/W Word | Y | Reg | | Y | NA | 96 |
| USER_DATA_02 | 0xB2 | OEM RESERVED. Typically used for part serialization | R/W Word | N | Reg | | Y | NA | 96 |
| USER_DATA_03 | 0xB3 | An EEPROM word available for the user. | R/W Word | Y | Reg | | Y | 0x0000 | 96 |
| USER_DATA_04 | 0xB4 | An EEPROM word available for the user. | R/W Word | N | Reg | | Y | 0x0000 | 96 |
| MFR_INFO | 0xB6 | Manufacturing specific information. | R Word | N | Reg | | | NA | 105 |
| MFR_EE_UNLOCK | 0xBD | Contact factory. | | | | | | | 115 |
| MFR_EE_ERASE | 0xBE | Contact factory. | | | | | | | 115 |
| MFR_EE_DATA | 0xBF | Contact factory. | | | | | | | 115 |
| MFR_CHAN_CONFIG_LTC3889 | 0xD0 | Configuration bits that are channel specific. | R/W Byte | Y | Reg | | Y | 0x1D | 70 |
| MFR_CONFIG_ALL_LTC3889 | 0xD1 | General configuration bits. | R/W Byte | N | Reg | | Y | 0x21 | 70 |
| MFR_FAULT_PROPAGATE_LTC3889 | 0xD2 | Configuration that determines which faults are propagated to the FAULT pin. | R/W Word | Y | Reg | | Y | 0x6993 | 94 |
| MFR_PWM_COMP | 0xD3 | PWM loop compensation configuration | R/W Byte | Y | Reg | | Y | 0x70 | 73 |
| MFR_PWM_MODE_LTC3889 | 0xD4 | Configuration for the PWM engine. | R/W Byte | Y | Reg | | Y | 0xC1 | 72 |
| MFR_FAULT_RESPONSE | 0xD5 | Action to be taken by the device when the FAULT pin is externally asserted low. | R/W Byte | Y | Reg | | Y | 0xC0 | 96 |
| MFR_OT_FAULT_RESPONSE | 0xD6 | Action to be taken by the device when an internal overtemperature fault is detected. | R Byte | N | Reg | | | 0xC0 | 92 |
| MFR_IOUT_PEAK | 0xD7 | Report the maximum measured value of READ_IOUT since last MFR_CLEAR_PEAKS. | R Word | Y | L11 | A | | NA | 107 |
| MFR_ADC_CONTROL | 0xD8 | ADC telemetry parameter selected for repeated fast ADC read back | R/W Byte | N | Reg | | | 0x00 | 107 |
| MFR_RETRY_DELAY | 0xDB | Retry interval during FAULT retry mode. | R/W Word | Y | L11 | ms | Y | 350.0 0xFABC | 87 |
| MFR_RESTART_DELAY | 0xDC | Minimum time the RUN pin is held low by the LTC3889. | R/W Word | Y | L11 | ms | Y | 500.0 0xFBE8 | 86 |
| MFR_VOUT_PEAK | 0xDD | Maximum measured value of READ_VOUT since last MFR_CLEAR_PEAKS. | R Word | Y | L16 | V | | NA | 108 |
| MFR_VIN_PEAK | 0xDE | Maximum measured value of READ_VIN since last MFR_CLEAR_PEAKS. | R Word | N | L11 | V | | NA | 108 |
| MFR_TEMPERATURE_1_PEAK | 0xDF | Maximum measured value of external Temperature (READ_TEMPERATURE_1) since last MFR_CLEAR_PEAKS. | R Word | Y | L11 | C | | NA | 108 |
| MFR_READ_IIN_PEAK | 0xE1 | Maximum measured value of READ_IIN command since last MFR_CLEAR_PEAKS | R Word | N | L11 | A | | NA | 108 |
| MFR_CLEAR_PEAKS | 0xE3 | Clears all peak values. | Send Byte | N | | | | NA | 100 |
| MFR_READ_ICHIP | 0xE4 | Measured supply current of the LTC3889 | R Word | N | L11 | A | | NA | 108 |

PMBus COMMAND SUMMARY

| COMMAND NAME | CMD CODE | DESCRIPTION | TYPE | PAGED | DATA FORMAT | UNITS | EEPROM | DEFAULT VALUE | PAGE |
|------------------------|----------|---|-----------|-------|-------------|--------|--------|----------------|---------------------|
| MFR_PADS | 0xE5 | Digital status of the I/O pads. | R Word | N | Reg | | | NA | 104 |
| MFR_ADDRESS | 0xE6 | Sets the 7-bit I ² C address byte. | R/W Byte | N | Reg | | Y | 0x4F | 69 |
| MFR_SPECIAL_ID | 0xE7 | Manufacturer code representing the LTC3889 and revision | R Word | N | Reg | | | 0x490X | 97 |
| MFR_IIN_CAL_GAIN | 0xE8 | The resistance value of the input current sense element in mΩ. | R/W Word | N | L11 | mΩ | Y | 5.0 0xCA80 | 82 |
| MFR_FAULT_LOG_STORE | 0xEA | Command a transfer of the fault log from RAM to EEPROM. | Send Byte | N | | | | NA | 112 |
| MFR_FAULT_LOG_CLEAR | 0xEC | Initialize the EEPROM block reserved for fault logging. | Send Byte | N | | | | NA | 115 |
| MFR_FAULT_LOG | 0xEE | Fault log data bytes. | R Block | N | Reg | | Y | NA | 111 |
| MFR_COMMON | 0xEF | Manufacturer status bits that are common across multiple ADI chips. | R Byte | N | Reg | | | NA | 104 |
| MFR_COMPARE_USER_ALL | 0xF0 | Compares current command contents with EEPROM. | Send Byte | N | | | | NA | 110 |
| MFR_TEMPERATURE_2_PEAK | 0xF4 | Peak internal die temperature since last MFR_CLEAR_PEAKS. | R Word | N | L11 | C | | NA | 108 |
| MFR_PWM_CONFIG_LTC3889 | 0xF5 | Set numerous parameters for the DC/DC controller including phasing. | R/W Byte | N | Reg | | Y | 0x10 | 75 |
| MFR_IOUT_CAL_GAIN_TC | 0xF6 | Temperature coefficient of the current sensing element. | R/W Word | Y | CF | ppm/°C | Y | 0 0x0000 | 80 |
| MFR_RVIN | 0xF7 | The resistance value of the V _{IN} pin filter element in mΩ. | R/W Word | N | L11 | mΩ | Y | 2000 0x0BE8 | 77 |
| MFR_TEMP_1_GAIN | 0xF8 | Sets the slope of the external temperature sensor. | R/W Word | Y | CF | | Y | 1.0 0x4000 | 83 |
| MFR_TEMP_1_OFFSET | 0xF9 | Sets the offset of the external temperature sensor with respect to -273.1°C | R/W Word | Y | L11 | C | Y | 0.0 0x8000 | 83 |
| MFR_RAIL_ADDRESS | 0xFA | Common address for PolyPhase outputs to adjust common parameters. | R/W Byte | Y | Reg | | Y | 0x80 | 69 |
| MFR_RESET | 0xFD | Commanded reset without requiring a power down. | Send Byte | N | | | | NA | 72 |

Note 1: Commands indicated with Y in the EEPROM column indicate that these commands are stored and restored using the STORE_USER_ALL and RESTORE_USER_ALL commands, respectively.

Note 2: Commands with a default value of NA indicate “not applicable”. Commands with a default value of FS indicate “factory set on a per part basis”.

Note 3: The LTC3889 contains additional commands not listed in this table. Reading these commands is harmless to the operation of the IC; however, the contents and meaning of these commands can change without notice.

Note 4: Some of the unpublished commands are read-only and will generate a CML bit 6 fault if written.

Note 5: Writing to commands not published in this table is not permitted.

Note 6: The user should not assume compatibility of commands between different parts based upon command names. Always refer to the manufacturer’s data sheet for each part for a complete definition of a command’s function.

ADI strives to keep command functionality compatible between all ADI devices. Differences may occur to address specific product requirements.

APPLICATIONS INFORMATION

The Typical Application on the last page of this data sheet is a common LTC3889 application circuit. The LTC3889 can be configured to use either DCR (inductor resistance) sensing or low value resistor sensing. The choice between the two current sensing schemes is largely a design trade-off between cost, power consumption and accuracy. DCR sensing is popular because it saves expensive current sensing resistors and is more power efficient, especially in high current applications. The LTC3889 can nominally account for the temperature dependency of the DCR sensing element. The accuracy of the current reading and current limit are typically limited by the accuracy of the DCR of the inductor (which is programmed as the IOUT_CAL_GAIN register of the LTC3889). However, current sensing resistors provide the most accurate current sense and limiting. Other external component selections are driven by the load requirement, and begins with the selection of R_{SENSE} (if R_{SENSE} is used) and inductor value. Next, the power MOSFETs are selected. Then the input and output capacitors are selected. Finally the current limit is selected. All of these components and ranges are required to be determined prior to selecting the RITH and EA_GM values in the MFR_PWM_COMP register and calculating the external compensation components. The current limit range is required because the two ranges (25mV to 50mV vs 37.5mV to 75mV) have different EA gains set with bit 7 of the MFR_PWM_MODE_LTC3889 command. The voltage RANGE bit also affects the loop gain and impacts the compensation network. The voltage RANGE is set with bit 1 of MFR_PWM_MODE_LTC3889. All other programmable parameters do not affect the loop gain, allowing parameters to be modified without impacting the transient response to load changes.

CURRENT LIMIT PROGRAMMING

The LTC3889 has two ranges of current limit programming and a total of eight levels within each range. Refer to the IOUT_OC_FAULT_LIMIT section of the PMBus commands. Within each range the error amp gain is fixed, resulting in constant loop gain. The LTC3889 will account for the temperature coefficient of the inductor DCR and automatically adjust the current limit when inductor temperature changes. The temperature coefficient of the DCR is stored in the MFR_IOUT_CAL_GAIN_TC command.

For the best current limit accuracy, use the 75mV setting. The 25mV setting will allow for the use of very low DCR inductors or sense resistors, but at the expense of current limit accuracy. Peak current limiting is on a cycle-by-cycle basis. The average inductor current is monitored by the ADC converter and can provide a warning if too much average output current is detected. An overcurrent fault is detected when the I_{TH} voltage exceeds the limit set by IOUT_OC_FAULT_LIMIT. The digital processor within the LTC3889 provides the ability to either ignore the fault, shut down and latch off or shut down and retry indefinitely (retry). Refer to the overcurrent portion of the Operation section for more detail.

I_{SENSE}^+ and I_{SENSE}^- PINS

The I_{SENSE}^+ and I_{SENSE}^- pins are the inputs to the current comparator and the A/D. The common mode input voltage range of the current comparators is 0V to 40V. Both the SENSE pins are high impedance inputs with small input currents typically less than 1 μ A. The high impedance inputs to the current comparators enable accurate DCR sensing. Do not float these pins during normal operation.

Filter components connected to the I_{SENSE} traces should be placed close to the IC. The positive and negative traces should be routed differentially and Kelvin connected to the current sense element, see Figure 24. A non-Kelvin connection or improper placement can add parasitic inductance and capacitance to the current sense element, degrading the signal at the sense terminals and making the programmed current limit perform poorly. In a PolyPhase system, poor placement of the sensing element will result in sub-optimal current sharing between power stages. If DCR sensing is used (Figure 25a), sense resistor R1 should be placed close to the inductor to prevent noise from coupling into sensitive small-signal nodes. The capacitor C1 should be placed close to the IC pins. Any impedance difference

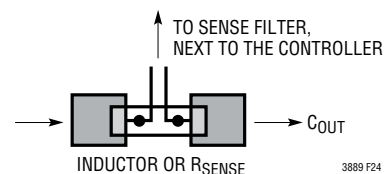
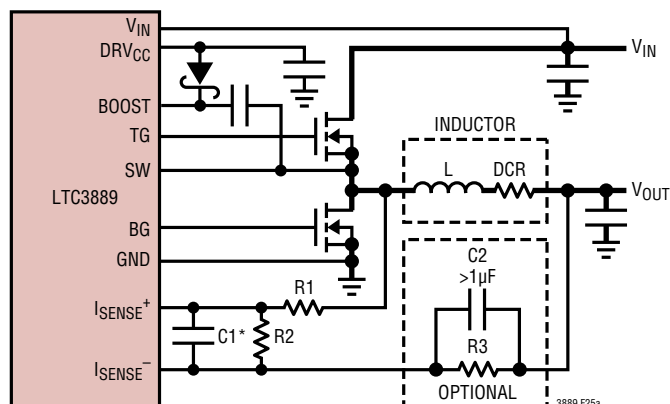

Figure 24. Optimal Sense Line Placement

APPLICATIONS INFORMATION

between the I_{SENSE}^+ and I_{SENSE}^- signal paths can result in loss of accuracy in the current reading of the ADC. The current reading accuracy can be improved by matching the impedance of the two signal paths. To accomplish this add a series resistor between V_{OUT} and I_{SENSE}^- equal to $R1$. A capacitor of $1\mu F$ or greater should be placed in parallel with this resistor. If the peak voltage is $<75mV$ at room temperature, $R2$ is not required.



$$((R1 + R3) || R2) \times C1 = \frac{2 \times L}{DCR} \quad I_{OUT_CAL_GAIN} = DCR \times \frac{R2}{R1 + R2 + R3}$$

$$R3 = R1$$

*PLACE C1 NEAR SENSE+, SENSE- PINS

Figure 25a. Inductor DCR Current Sense Circuit

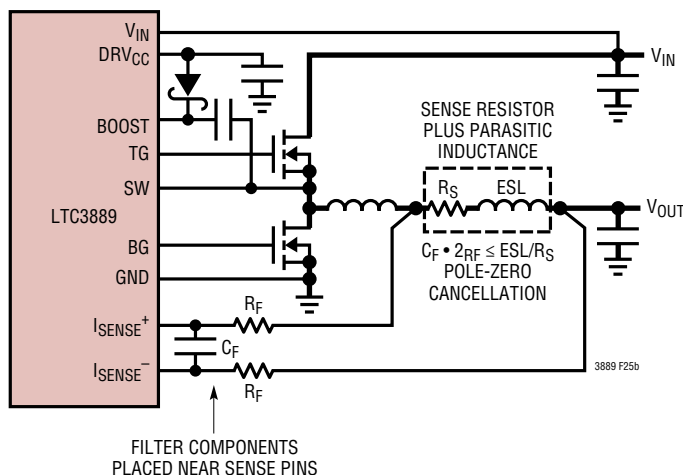

Figure 25b. Resistor Current Sense Circuit

LOW VALUE RESISTOR CURRENT SENSING

A typical sensing circuit using a discrete resistor is shown in Figure 25b. R_{SENSE} is chosen based on the required output current.

The current comparator has a maximum threshold $V_{SENSE(MAX)}$ determined by the I_{LIMIT} setting. The current comparator threshold sets the peak of the inductor current, yielding a maximum average output current I_{MAX} equal to the peak value less half the peak-to-peak ripple current ΔI_L . To calculate the sense resistor value, use the equation:

$$R_{SENSE} = \frac{V_{SENSE(MAX)}}{I_{MAX} + \frac{\Delta I_L}{2}}$$

Due to possible PCB noise in the current sensing loop, the AC current sensing ripple of $\Delta V_{SENSE} = \Delta I_L \cdot R_{SENSE}$ also needs to be checked in the design to get a good signal-to-noise ratio. In general, for a reasonably good PCB layout, a $15mV$ minimum ΔV_{SENSE} voltage is recommended as a conservative number to start with, either for R_{SENSE} or DCR sensing applications.

For previous generation current mode controllers, the maximum sense voltage was high enough (e.g., $75mV$ for the LTC1628/LTC3728 family) that the voltage drop across the parasitic inductance of the sense resistor represented a relatively small error. In the newer and higher current density solutions, the value of the sense resistor can be less than $1m\Omega$ and the peak sense voltage can be less than $20mV$. Also, inductor ripple currents greater than 50% with operation up to $750kHz$ are becoming more common. Under these conditions, the voltage drop across the sense resistor's parasitic inductance is no longer negligible. A typical sensing circuit using a discrete resistor is shown in Figure 25b. In previous generations of controllers, a small RC filter placed near the IC was commonly used to reduce the effects of the capacitive and inductive noise coupled in the sense traces on the PCB. A typical filter consists of two series 100Ω resistors connected to a parallel $1000pF$ capacitor, resulting in a time constant of $200ns$.

APPLICATIONS INFORMATION

This same RC filter with minor modifications, can be used to extract the resistive component of the current sense signal in the presence of parasitic inductance. For example, Figure 26 illustrates the voltage waveform across a 2mΩ resistor with a PCB footprint of 2010. The waveform is the superposition of a purely resistive component and a purely inductive component. It was measured using two scope probes and waveform math to obtain a differential measurement. Based on additional measurements of the inductor ripple current and the on-time, t_{ON} , and off-time, t_{OFF} , of the top switch, the value of the parasitic inductance was determined to be 0.5nH using the equation:

$$ESL = \frac{V_{ESL(STEP)}}{\Delta I_L} \cdot \frac{t_{ON} \cdot t_{OFF}}{t_{ON} + t_{OFF}} \quad (1)$$

If the RC time constant is chosen to be close to the parasitic inductance divided by the sense resistor (L/R), the resultant waveform looks resistive, as shown in Figure 27. For applications using low maximum sense voltages, check the sense resistor manufacturer's data sheet for information about parasitic inductance. In the absence of data, measure the voltage drop directly across the sense

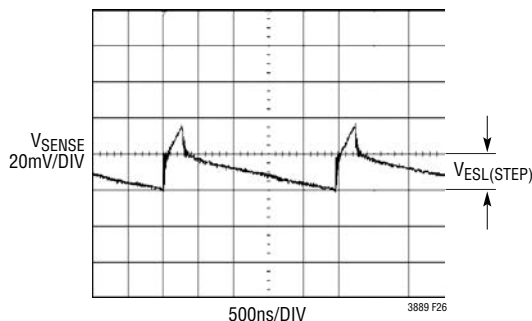

Figure 26. Voltage Measured Directly Across R_{SENSE}

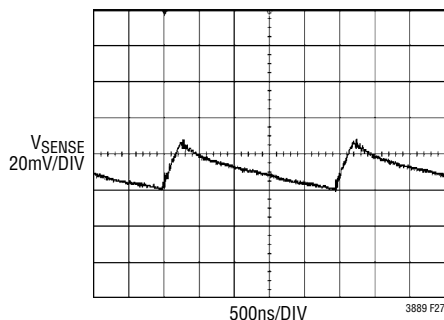

Figure 27. Voltage Measured After the R_{SENSE} Filter

resistor to extract the magnitude of the ESL step and use Equation 1 to determine the ESL. However, do not overfilter the signal. Keep the RC time constant less than or equal to the inductor time constant to maintain a sufficient ripple voltage on V_{RSENSE} for optimal operation of the current loop controller.

INDUCTOR DCR CURRENT SENSING

For applications requiring the highest possible efficiency at high load currents, the LTC3889 is capable of sensing the voltage drop across the inductor DCR, as shown in Figure 25a. The DCR of the inductor represents the small amount of DC winding resistance of the copper, which can be less than 1mΩ for today's low value, high current inductors. In a high current application requiring such an inductor, conduction loss through a sense resistor would reduce the efficiency by a few percent compared to DCR sensing.

If $R1 = R3$ and the external $(R1 + R3) || R2 \cdot C1$ time constant is chosen to be exactly equal to the $2 \cdot L/DCR$ time constant, assuming $R1 = R3$, the voltage drop across the external capacitor, $C1$, is equal to the drop across the inductor DCR multiplied by $R2/(R1 + R2 + R3)$. $R2$ scales the voltage across the sense terminals for applications where the DCR is greater than the target sense resistor value. The DCR value is entered as the `IOUT_CAL_GAIN` in mΩ unless $R2$ is required. If $R2$ is used:

$$IOUT_CAL_GAIN = DCR \cdot \frac{R2}{R1 + R2 + R3}$$

$R2$ can be removed if there is no need to attenuate the current sense signal in order to remain within the desired current sense range. To properly select the external filter components, the DCR of the inductor must be known. It can be measured using an accurate RLC meter, but the DCR tolerance is not always the same and varies with temperature. Consult the inductor manufacturers' data sheets for detailed information. The LTC3889 will correct for temperature variation if the correct temperature coefficient value is entered into the `MFR_IOUT_CAL_GAIN_TC` command. Typically the resistance has a 3900ppm/°C coefficient.

APPLICATIONS INFORMATION

Assuming $R1 = R3$, $C2$ can be optimized for a flat frequency response using the following equation:

$$C2 = \frac{2R1 \cdot R2 \cdot C1 - \frac{L}{DCR} (2R1 + R2)}{R1^2}$$

Using the inductor ripple current value from the Inductor Value Calculation section, the target sense resistor value is:

$$R_{SENSE(EQUIV)} = \frac{V_{SENSE(MAX)}}{I_{MAX} + \frac{\Delta I_L}{2}}$$

To ensure that the application will deliver full load current over the full operating temperature range, be sure to pick the optimum I_{LIMIT} value accounting for tolerance in the DCR versus the `MFR_IOUT_CAL_GAIN` parameter entered.

Next, determine the DCR of the inductor. Use the manufacturer's maximum value, which is usually specified at 20°C. Increase this value to account for tolerances in the temperature sensing element of 3°C to 5°C and any additional temperature differences associated with the proximity of the temperature sensor element to the inductor.

$C1$ is usually selected to be in the range of 0.047µF to 4.7µF. This forces $(R1 + R3) || R2$ to be approximately 2k. Adding optional elements $R3$ and $C2$ shown in Figure 25a will minimize offset errors associated with the I_{SENSE} leakage currents. Set $R3$ equal to the value of $R1$. Set $C2$ to a value of 1µF or greater to ensure adequate noise filtering.

The equivalent resistance $(R1 + R3) || R2$ is scaled to the room temperature inductance and maximum DCR:

$$(R1 + R3) || R2 = \frac{2 \cdot L}{(DCR \text{ at } 20^\circ\text{C}) \cdot C1}$$

The maximum power loss in $R1$ is related to the duty cycle, and will occur in continuous mode at the maximum input voltage:

$$P_{LOSS R1} = \frac{(V_{IN(MAX)} - V_{OUT}) \cdot V_{OUT}}{R1}$$

Ensure that $R1$ has a power rating higher than this value. If high efficiency is necessary at light loads, consider this

power loss when deciding whether to use DCR sensing or sense resistors. Light load power loss can be modestly higher with a DCR network than with a sense resistor due to the extra switching losses incurred through $R1$. However, DCR sensing eliminates a sense resistor, reducing conduction losses and provides higher efficiency at heavy loads. Peak efficiency is about the same with either method. Selecting discontinuous mode will improve the converter efficiency at light loads regardless of the current sensing method.

To maintain a good signal-to-noise ratio for the current sense signal, use a minimum ΔV_{ISENSE} of 10mV to 15mV. For a DCR sensing application, the actual ripple voltage will be determined by the equation:

$$\Delta V_{ISENSE} = \frac{V_{IN} - V_{OUT}}{R1 \cdot C1} \cdot \frac{V_{OUT}}{V_{IN} \cdot f_{OSC}}$$

DCR sensing is not recommended at input voltages above 24V. The voltage coefficient of $R1$ at higher input voltages can cause significant errors in current sense voltage. If DCR sensing must be used at higher input voltages, the $R1$ resistor must have the lowest voltage coefficient possible.

SLOPE COMPENSATION AND INDUCTOR PEAK CURRENT

Slope compensation provides stability in constant frequency current mode architectures by preventing sub-harmonic oscillations at high duty cycles. This is accomplished internally by adding a compensation ramp to the inductor current signal. The LTC3889 uses a patented current limit technique that cancels the effect of the compensating ramp. This allows the maximum inductor peak current to remain unaffected throughout all duty cycles.

INDUCTOR VALUE CALCULATION

Given the desired input and output voltages, the inductor value and operating frequency, f_{OSC} , directly determine the inductor peak-to-peak ripple current:

$$I_{RIPPLE} = \frac{V_{OUT} (V_{IN} - V_{OUT})}{V_{IN} \cdot f_{OSC} \cdot L}$$

APPLICATIONS INFORMATION

Lower ripple current reduces core losses in the inductor, ESR losses in the output capacitors, and output voltage ripple. Thus, highest efficiency operation is obtained at the lowest frequency with a small ripple current. Achieving this, however, requires a large inductor.

A reasonable starting point is to choose a ripple current that is about 40% of $I_{OUT(MAX)}$. Note that the largest ripple current occurs at the highest input voltage. To guarantee that the ripple current does not exceed a specified maximum, the inductor should be chosen according to:

$$L \geq \frac{V_{OUT}(V_{IN} - V_{OUT})}{V_{IN} \cdot f_{OSC} \cdot I_{RIPPLE}}$$

INDUCTOR CORE SELECTION

Once the inductor value is determined, the type of inductor must be selected. Core loss is independent of core size for a fixed inductor value, but it is very dependent on inductance. As the inductance increases, core losses go down. Unfortunately, increased inductance requires more turns of wire and therefore copper losses increase.

Ferrite designs have very low core loss and are preferred at high switching frequencies, so design goals can concentrate on copper loss and preventing saturation. Ferrite core materials saturate hard, which means that the inductance collapse abruptly when the peak design current is exceeded. This results in an abrupt increase in inductor ripple current and consequent output voltage ripple. Do not allow the core to saturate!

POWER MOSFET AND OPTIONAL SCHOTTKY DIODE SELECTION

Two external power MOSFETs must be selected for each output channel in the LTC3889: one N-channel MOSFET for the top (main) switch, and one N-channel MOSFET for the bottom (synchronous) switch.

The peak-to-peak gate drive levels are set by the DRV_{CC} voltage. Pay close attention to the BV_{DSS} specification for the MOSFETs as well; most of the logic-level MOSFETs are limited to 30V or less.

Selection criteria for the power MOSFETs include the on-resistance, $R_{DS(ON)}$, Miller capacitance, C_{MILLER} , input voltage and maximum output current. Miller capacitance, C_{MILLER} , can be approximated from the gate charge curve usually provided on the MOSFET manufacturers' data sheet. C_{MILLER} is equal to the increase in gate charge along the horizontal axis while the curve is approximately flat divided by the specified change in V_{DS} . This result is then multiplied by the ratio of the application applied V_{DS} to the gate charge curve specified V_{DS} . When the IC is operating in continuous mode the duty cycles for the top and bottom MOSFETs are given by:

$$\text{Main Switch Duty Cycle} = \frac{V_{OUT}}{V_{IN}}$$

$$\text{Synchronous Switch Duty Cycle} = \frac{V_{IN} - V_{OUT}}{V_{IN}}$$

The MOSFET power dissipations at maximum output current are given by:

$$P_{MAIN} = \frac{V_{OUT}}{V_{IN}} (I_{MAX})^2 (1 + \delta) R_{DS(ON)} + (V_{IN})^2 \left(\frac{I_{MAX}}{2} \right) (R_{DR}) (C_{MILLER}) \cdot \left[\frac{1}{V_{DRVCC} - V_{TH(MIN)}} + \frac{1}{V_{TH(MIN)}} \right] \cdot f_{OSC}$$

$$P_{SYNC} = \frac{V_{IN} - V_{OUT}}{V_{IN}} (I_{MAX})^2 (1 + \delta) R_{DS(ON)}$$

where δ is the temperature dependency of $R_{DS(ON)}$ and R_{DR} (approximately 2Ω) is the effective driver resistance at the MOSFET's Miller threshold voltage. $V_{TH(MIN)}$ is the typical MOSFET minimum threshold voltage.

Both MOSFETs have I^2R losses while the topside N-channel equation includes an additional term for transition losses, which are highest at high input voltages. For $V_{IN} < 20V$ the high current efficiency generally improves with larger MOSFETs, while for $V_{IN} > 20V$ the transition losses rapidly increase to the point that the use of a higher $R_{DS(ON)}$ device with lower C_{MILLER} actually provides higher efficiency. The

APPLICATIONS INFORMATION

synchronous MOSFET losses are greatest at high input voltage when the top switch duty factor is low or during a short-circuit when the synchronous switch is on close to 100% of the period.

The term $(1 + \delta)$ is generally given for a MOSFET in the form of a normalized $R_{DS(ON)}$ vs Temperature curve, but $\delta = 0.005/^\circ\text{C}$ can be used as an approximation for low voltage MOSFETs.

The optional Schottky diodes connected from ground to SW_n conduct during the dead time between the conduction of the two power MOSFETs. These prevent the body diodes of the bottom MOSFETs from turning on, storing charge during the dead time and requiring a reverse recovery period that could cost as much as 3% in efficiency at high V_{IN} . A 1A to 3A Schottky is generally a good compromise for both regions of operation due to the relatively small average current. Larger diodes result in additional transition losses due to their larger junction capacitance.

C_{IN} AND C_{OUT} SELECTION

In continuous mode, the source current of the top MOSFET is a square wave of duty cycle $(V_{OUT})/(V_{IN})$. To prevent large voltage transients, a low ESR capacitor sized for the maximum RMS current of one channel must be used. The maximum RMS capacitor current is given by:

$$C_{IN} \text{ Required } I_{RMS} \approx \frac{I_{MAX}}{V_{IN}} \left[(V_{OUT})(V_{IN} - V_{OUT}) \right]^{1/2}$$

This formula has a maximum at $V_{IN} = 2 \cdot V_{OUT}$, where $I_{RMS} = I_{OUT}/2$. This simple worst-case condition is commonly used for design because even significant deviations do not offer much relief. Note that capacitor manufacturers' ripple current ratings are often based on only 2000 hours of life. This makes it advisable to further derate the capacitor, or to choose a capacitor rated at a higher temperature than required. Several capacitors may be paralleled to meet size or height requirements in the design. Due to the high operating frequency of the LTC3889, ceramic capacitors can also be used for C_{IN} . Always consult the manufacturer if there is any question.

The benefit of using a LTC3889 in 2-phase operation can be calculated by using the equation above for the higher

power channel and then calculating the loss that would have resulted if both controller channels switched on at the same time. The total RMS power lost is lower when both channels are operating due to the reduced overlap of current pulses required through the input capacitor's ESR. This is why the input capacitor's requirement calculated above for the worst-case scenario is adequate for the dual controller design. Also, if applicable the power losses due to the input protection fuse resistance, V_{IN} source impedance, and PC board trace resistance losses are also reduced due to the reduced peak currents in a 2-phase system. The overall benefit of a multiphase design will only be fully realized when the source impedance of the V_{IN} power supply/battery is included in the efficiency testing. The drain terminals of the top MOSFETs should be placed within 1cm of each other and share a common $C_{IN}(s)$. Separating the sources and C_{IN} may produce undesirable voltage and current resonances on V_{IN} .

A small (0.1 μF to 1 μF) bypass capacitor between the chip V_{IN} pin and ground, placed close to the LTC3889, is also suggested. A 2.2 Ω to 10 Ω R_{VIN} resistor placed between C_{IN} (C1) and the V_{IN} pin provides further isolation if multiple LTC3889s are used.

The selection of C_{OUT} is driven by the effective series resistance (ESR). Typically, once the ESR requirement is satisfied, the capacitance is adequate for filtering. The output ripple (ΔV_{OUT}) is approximated by:

$$\Delta V_{OUT} \approx I_{RIPPLE} \left(\text{ESR} + \frac{1}{8fC_{OUT}} \right)$$

where f is the operating frequency, C_{OUT} is the output capacitance and I_{RIPPLE} is the ripple current in the inductor. The output ripple is highest at maximum input voltage since I_{RIPPLE} increases with input voltage.

VARIABLE DELAY TIME, SOFT-START AND OUTPUT VOLTAGE RAMPING

The LTC3889 must enter the run state prior to soft-start. The RUN_n pin is released after the part initializes and V_{IN} is greater than the V_{IN_ON} threshold. If multiple LTC3889s are used in an application, they should be configured to share the same RUN_n pins. They all hold their respective

APPLICATIONS INFORMATION

RUN n pins low until all devices initialize and V_{IN} exceeds the VIN_ON threshold for all devices. The SHARE_CLK pin assures all the devices connected to the signal use the same time base for time delay operations.

After the RUN n pin releases, the controller waits for the user-specified turn-on delay (TON_DELAY) prior to initiating an output voltage ramp. Multiple LTC3889s and other ADI parts can be configured to start with equal or unique delay times. To work within a desired synchronization scheme all devices must use the same timing clock (SHARE_CLK) and all devices must share the RUN n pin. This allows the relative delay of all parts to be synchronized. The actual variation in the delays will be dependent on the highest clock rate of the devices connected to the SHARE_CLK pin (all Analog Devices ICs are configured to allow the fastest SHARE_CLK signal to control the timing of all devices). The SHARE_CLK signal can be $\pm 10\%$ in frequency, thus the actual time delays will have proportional variance.

Soft-start is performed by actively regulating the load voltage while digitally ramping the target voltage from 0.0V to the commanded voltage set point. The rise time of the voltage ramp can be programmed using the TON_RISE command to minimize inrush currents associated with the start-up voltage ramp. The soft-start feature is disabled by setting TON_RISE to any value less than 0.250ms. The LTC3889 will perform the necessary math to assure the voltage ramp is controlled to the desired slope. However, the voltage slope can not be any faster than the fundamental limits of the power stage. The shorter TON_RISE time is set, the larger the discrete steps in the TON_RISE ramp will appear. The number of steps in the ramp is equal to TON_RISE/0.1ms.

The LTC3889 PWM will always use discontinuous mode during the TON_RISE operation. In discontinuous mode, the bottom gate is turned off as soon as reverse current is detected in the inductor. This will allow the regulator to start up into a pre-biased load.

The LTC3889 does not include a traditional tracking feature. However, two outputs can be given the same TON_RISE and TON_DELAY times to effectively ramp up at the same time. If the RUN pin is released at the same time and both

LTC3889s use the same time base, the outputs will track very closely. If the circuit is in a PolyPhase configuration, all timing parameters for that rail must be the same.

The previously described method of start-up sequencing is time based. For concatenated events it is possible to control the RUN n pins based on the $\overline{\text{FAULT}}_n$ pin of a different controller, or the PGOOD n pin(s) of the LTC3889. The $\overline{\text{FAULT}}_n$ pins can be configured to release when the output voltage of the converter is greater than the VOUT_UV_FAULT_LIMIT. It is recommended to use the deglitched VOUT UV fault limit because there is little appreciable time delay between the converter crossing the UV threshold and the $\overline{\text{FAULT}}_n$ pin releasing. The deglitched output can be enabled by setting the MFR_FAULT_propagate_vout_uvuf bit in the MFR_FAULT_PROPAGATE_LTC3889 command. Refer to the MFR section of the PMBus commands in this document. The UV comparator output signal may have some glitching as the VOUT signal transitions through the comparator threshold. The LTC3889 includes a 70 μ s digital deglitch filter to greatly reduce the probability of multiple transitions. To minimize the risk of $\overline{\text{FAULT}}_n$ pins glitching, make the TON_RISE times less than 100ms. If unwanted transitions still occur on $\overline{\text{FAULT}}_n$, place a capacitor to ground on the $\overline{\text{FAULT}}_n$ pin to filter the waveform. The RC time-constant of the filter should be set sufficiently fast to assure no appreciable delay is incurred. A delay of 300 μ s to 500 μ s will provide some additional filtering without significantly delaying the trigger event.

DIGITAL SERVO MODE

For maximum accuracy in the regulated output voltage, enable the digital servo loop by asserting bit 6 of the MFR_PWM_MODE_LTC3889 command. In digital servo mode the LTC3889 will adjust the regulated output voltage based on the ADC voltage reading. Every 90ms the digital servo loop will step the LSB of the DAC (nominally 10mV or 2mV depending on the voltage range bit) until the output is at the correct ADC reading. At power-up this mode engages after TON_MAX_FAULT_LIMIT unless the limit is set to 0 (infinite). If the TON_MAX_FAULT_LIMIT is set to 0 (infinite), the servo begins after TON_RISE is complete and VOUT has exceeded the VOUT_UV_FAULT_LIMIT.

APPLICATIONS INFORMATION

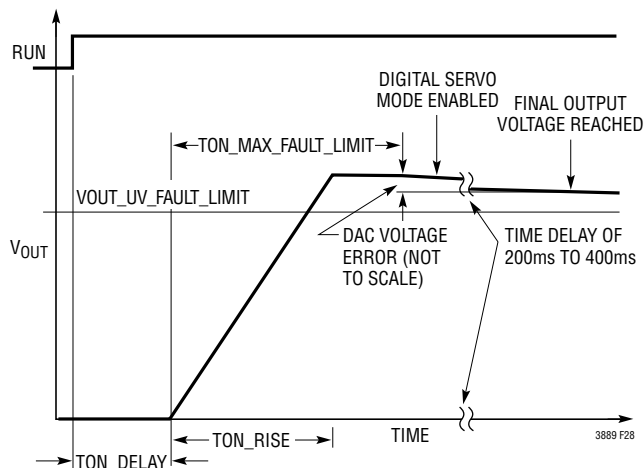

Figure 28. Timing Controlled V_{OUT} Rise

This same point in time is when the output changes from discontinuous to the programmed mode as indicated in MFR_PWM_MODE_LTC3889 bit 0. Refer to Figure 28 for details on the V_{OUT} waveform under time-based sequencing.

If the TON_MAX_FAULT_LIMIT is set to a value greater than 0 and the TON_MAX_FAULT_RESPONSE is set to ignore (0x00), the servo begins:

1. After the TON_RISE sequence is complete
2. After the TON_MAX_FAULT_LIMIT time is reached.
3. After the VOUT_UV_FAULT_LIMIT has been exceeded or the IOUT_OC_FAULT_LIMIT is not longer active.

If the TON_MAX_FAULT_LIMIT is set to a value greater than 0 and the TON_MAX_FAULT_RESPONSE is not set to ignore 0x00, the servo begins:

1. After the TON_RISE sequence is complete;
2. After the TON_MAX_FAULT_LIMIT time has expired and both VOUT_UV_FAULT and IOUT_OC_FAULT are not present.

The maximum rise time is limited to 1.3 seconds.

In a PolyPhase application only one phase should have digital servo mode enabled. This will ensure the phases servo to the same output regulation point.

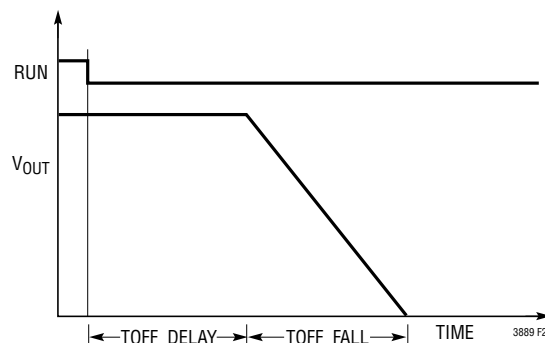

Figure 29. TOFF_DELAY and TOFF_FALL

SOFT OFF (SEQUENCED OFF)

In addition to a controlled start-up, the LTC3889 also supports controlled turn-off. The TOFF_DELAY and TOFF_FALL functions are shown in Figure 29. TOFF_FALL is processed when the RUN pin goes low or if the part is commanded off. If the part faults off or $\overline{\text{FAULT}}_n$ is pulled low externally and the part is programmed to respond to $\overline{\text{FAULT}}_n$, the output will three-state by turning off both the main and synchronous MOSFETs turned off. The output will decay as a function of the load rather than exhibiting a controlled ramp.

The output voltage will ramp as shown in Figure 29 so long as the part is in forced continuous mode and the TOFF_FALL time is slow enough that the power stage can achieve the desired slope. The TOFF_FALL time can only be met if the power stage and controller can sink sufficient current to assure the output is at zero volts by the end of the fall time interval. If the TOFF_FALL time is set shorter than the time required to discharge the load capacitance, the output will not reach the desired zero volt state. At the end of TOFF_FALL, the controller will cease to sink current and V_{OUT} will decay at the natural rate determined by the load impedance. If the controller is in discontinuous mode, the controller will not pull negative current and the output will be pulled low by the load, not the power stage. The maximum fall time is limited to 1.3 seconds. The shorter TOFF_FALL time is set, the larger the discrete steps of the TOFF_FALL ramp will appear. The number of steps in the ramp is typically $\text{TOFF_FALL}/0.1\text{ms}$.

APPLICATIONS INFORMATION

DRV_{CC} REGULATOR

The LTC3889 features a PMOS linear regulator that supplies power to DRV_{CC} from the V_{IN} or EXTV_{CC} supply. DRV_{CC} powers the gate drivers, V_{DD33} and much of the LTC3889 internal circuitry. The linear regulator produces 6.3V at the DRV_{CC} pin when V_{IN} or EXTV_{CC} is greater than approximately 8V when DRVSET = 0. The linear regulator produces 9V at the DRV_{CC} pin when V_{IN} or EXTV_{CC} is greater than approximately 10V when DRVSET = 2. The DRV_{CC} voltage is set to 7.4V when DRVSET = 1. The regulator can supply a peak current of 100mA and must be bypassed to ground with a minimum of 1μF ceramic capacitor or low ESR electrolytic capacitor. No matter what type of bulk capacitor is used, an additional 0.1μF ceramic capacitor placed directly adjacent to the DRV_{CC} and GND pins is highly recommended. Good bypassing is needed to supply the high transient currents required by the MOSFET gate drivers.

High input voltage applications in which large MOSFETs are being driven at high frequencies may cause the maximum die junction temperature rating for the LTC3889 to be exceeded. To reduce die temperature, the DRV_{CC} current, of which a large percentage is due to the gate charge current, may be supplied from either the V_{IN} or EXTV_{CC} pin. If the LTC3889 internal regulator is powered from the V_{IN} pin, the power through the IC is equal to V_{IN} • I_{DRVCC}. The gate charge current is dependent on operating frequency as discussed in the Efficiency Considerations section. The junction temperature can be estimated by using the equations in Note 2 of the Electrical Characteristics. For example, at 70°C ambient, the LTC3889 DRV_{CC} current is limited to less than 44mA from a 40V supply:

$$T_J = 70^\circ\text{C} + 44\text{mA} \cdot 40\text{V} \cdot 31^\circ\text{C/W} = 125^\circ\text{C}$$

To prevent the maximum junction temperature from being exceeded, the LTC3889 internal LDO can be powered from the EXTV_{CC} pin. If the EXTV_{CC} pin is not used to power DRV_{CC}, the EXTV_{CC} pin must be tied to GND, do not float this pin. The V_{IN} current resulting from the gate driver and control circuitry will be reduced to a minimum by supplying the DRV_{CC} current from the EXTV_{CC} pin with an external supply or an output derived source.

Tying the EXTV_{CC} pin to a 5V supply reduces the junction temperature in the previous example from 125°C to:

$$T_J = 70^\circ\text{C} + 44\text{mA} \cdot 5\text{V} \cdot 31^\circ\text{C/W} + 2\text{mA} \cdot 40\text{V} \cdot 31^\circ\text{C/W} = 80^\circ\text{C}$$

Do not tie DRV_{CC} on the LTC3889 to an external supply because DRV_{CC} will attempt to pull the external supply high and hit current limit, significantly increasing the die temperature.

For applications where the input voltage is less than 6V, tie the V_{IN} and DRV_{CC} pins together and tie the combined pins to the input with a 1Ω or 2.2Ω resistor as shown in Figure 30. To minimize the voltage drop caused by the gate charge current a low ESR capacitor must be connected to the V_{IN}/DRV_{CC} pins. This configuration will override the DRV_{CC} linear regulator and will prevent DRV_{CC} from dropping too low. Make sure the DRV_{CC} voltage exceeds the R_{DS(ON)} test voltage for the MOSFETs which is typically 4.5V for logic level devices. The UVLO on DRV_{CC} is set to approximately 4V.

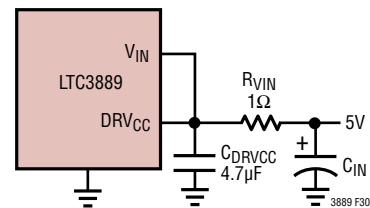

Figure 30. Setup for a 5V Input

TOPSIDE MOSFET DRIVER SUPPLY (C_B, D_B)

External bootstrap capacitors, C_B, connected to the BOOST_n pin supplies the gate drive voltages for the topside MOSFETs. Capacitor C_B in the Block Diagram is charged though external diode D_B from DRV_{CC} when the SW_n pin is low. When one of the topside MOSFETs is to be turned on, the driver places the C_B voltage across the gate source of the desired MOSFET. This enhances the MOSFET and turns on the topside switch. The switch node voltage, SW_n, rises to V_{IN} and the BOOST_n pin follows. With the topside MOSFET on, the boost voltage is above the input supply: V_{BOOST} = V_{IN} + V_{DRVCC}. The value of the boost capacitor

APPLICATIONS INFORMATION

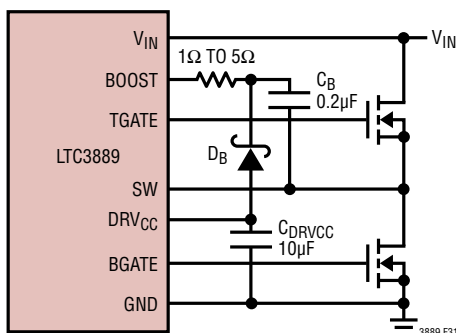

Figure 31. Boost Circuit to Minimize PWM Jitter

C_B needs to be 100 times that of the total input capacitance of the topside MOSFET(s). The reverse breakdown of the external Schottky diode must be greater than $V_{IN(MAX)}$.

PWM jitter has been observed in some designs operating at higher V_{IN}/V_{OUT} ratios. This jitter does not substantially affect the circuit accuracy. Referring to Figure 31, PWM jitter can be removed by inserting a series resistor with a value of 1Ω to 5Ω between the cathode of the diode and the BOOST n pin.

UNDERVOLTAGE LOCKOUT

The LTC3889 is initialized by an internal threshold-based UVLO where V_{IN} must be approximately 4V and DRV_{CC} , V_{DD33} , V_{DD25} must be within approximately 20% of the regulated values. In addition, V_{DD33} must be within approximately 7% of the targeted value before the RUN pin is released. After the part has initialized, an additional comparator monitors V_{IN} . The V_{IN_ON} threshold must be exceeded before the power sequencing can begin. When V_{IN} drops below the V_{IN_OFF} threshold, the SHARE_CLK pin will be pulled low and V_{IN} must increase above the V_{IN_ON} threshold before the controller will restart. The normal start-up sequence will be allowed after the V_{IN_ON} threshold is crossed. If \overline{FAULT}_n is held low when V_{IN} is applied, \overline{ALERT} will be asserted low even if the part is programmed to not assert \overline{ALERT} when \overline{FAULT}_n is held low. If I²C communication occurs before the LTC3889 is out of reset and only a portion of the command is seen by the part, this can be interpreted as a CML fault. If a CML fault is detected, \overline{ALERT} is asserted low.

It is possible to program the contents of the EEPROM in the application if the V_{DD33} supply is externally driven. This will activate the digital portion of the LTC3889 without engaging the high voltage sections. PMBus communications are valid in this supply configuration. If V_{IN} has not been applied to the LTC3889, bit 3 (EEPROM Not Initialized) in MFR_COMMON will be asserted low. If this condition is detected, the part will only respond to addresses 5A and 5B. To initialize the part issue the following set of commands: global address 0x5B command 0xBD data 0x2B followed by global address 0x5B command 0xBD and data 0xC4. The part will now respond to the correct address. Configure the part as desired then issue a STORE_USER_ALL. When V_{IN} is applied a MFR_RESET command must be issued to allow the PWM to be enabled and valid ADC conversions to be read.

FAULT INDICATIONS

The LTC3889 \overline{FAULT}_n pins are configurable to indicate a variety of faults including OV, UV, OC, OT, timing faults, peak overcurrent faults. In addition the \overline{FAULT}_n pins can be pulled low by external sources indicating a fault in some other portion of the system. The fault response is configurable and allows the following options:

- Ignore
- Shut Down Immediately—Latch Off
- Shut Down Immediately—Retry Indefinitely at the Time Interval Specified in MFR_RETRY_DELAY

Refer to the PMBus section of the data sheet and the PMBus specification for more details regarding fault responses.

The OV response is always automatic. If an OV condition is detected, TG n goes low and BG n is asserted.

APPLICATIONS INFORMATION

OPEN-DRAIN PINS

The LTC3889 has the following open-drain pins:

3.3V Pins

1. $\overline{\text{FAULT}}_n$
2. SYNC
3. SHARE_CLK
4. PGOOD $_n$

5V Pins (5V pins operate correctly when pulled to 1.8V.)

1. RUN $_n$
2. $\overline{\text{ALERT}}$
3. SCL
4. SDA

All the above pins have on-chip pull-down transistors that can sink 3mA at 0.4V. Unless there are transient speed issues associated with the RC time constant of the resistor pull-up and parasitic capacitance to ground, a 10k resistor or larger is generally recommended.

For high speed signals such as the SDA, SCL and SYNC, a lower value resistor may be required. The RC time constant should be set to 1/3 to 1/5 the required rise time to avoid timing issues. For a 100pF load and a 400kHz PMBus communication rate, the rise time must be less than 300ns. The resistor pull-up on the SDA and SCL pins with the time constant set to 1/3 the rise time:

$$R_{\text{PULLUP}} = \frac{t_{\text{RISE}}}{3 \cdot 100\text{pF}} = 1\text{k}$$

Minimize parasitic capacitance on the SDA and SCL pins to avoid communication problems. To estimate the loading capacitance, monitor the signal in question and measure how long it takes for the desired signal to reach approximately 63% of the output value. This is one time constant.

The SYNC pin has an on-chip pull-down transistor with the output held low for nominally 500ns. If the internal oscillator is set for 500kHz and the load is 100pF and a

3x time constant is required, the resistor calculation is as follows:

$$R_{\text{PULLUP}} = \frac{2\mu\text{s} - 500\text{ns}}{3 \cdot 100\text{pF}} = 5\text{k}$$

If timing errors are occurring or if the SYNC frequency is not as fast as desired, monitor the waveform and determine if the RC time constant is too long for the application. If possible reduce the parasitic capacitance. If not reduce the pull up resistor sufficiently to assure proper timing. The SHARE_CLK pull-up resistor has a similar equation with a period of 10us and a pull-down time of 1us. The RC time constant should be approximately 3us or faster.

PHASE-LOCKED LOOP AND FREQUENCY SYNCHRONIZATION

The LTC3889 has a phase-locked loop (PLL) comprised of an internal voltage-controlled oscillator (VCO) and a phase detector. The PLL is locked to the **falling** edge of the SYNC pin. The phase relationship between the PWM controller and the falling edge of SYNC is controlled by the lower 3 bits of the MFR_PWM_CONFIG_LTC3889 command. For PolyPhase applications, it is recommended all the phases be spaced evenly. Thus for a 2-phase system the signals should be 180° out of phase and a 4-phase system should be spaced 90°.

The phase detector is an edge-sensitive digital type that provides a known phase shift between the external and internal oscillators. This type of phase detector does not exhibit false lock to harmonics of the external clock.

The output of the phase detector is a pair of complementary current sources that charge or discharge the internal filter network. The PLL lock range is guaranteed between 85kHz to 500kHz. Nominal parts will have a range beyond this; however, operation to a wider frequency range is not guaranteed.

The PLL has a lock detection circuit. If the PLL should lose lock during operation, bit 4 of the STATUS_MFR_SPECIFIC command is asserted and the $\overline{\text{ALERT}}$ pin is pulled low. The fault can be cleared by writing a 1 to the bit. If the user

APPLICATIONS INFORMATION

does not want the $\overline{\text{ALERT}}$ pin to assert if a PLL_FAULT occurs, the SMBALERT_MASK command can be used to prevent the alert.

If there is no external signal applied to the SYNC pin in the application, the nominal programmed frequency will control the PWM circuitry. If FREQUENCY_SWITCH is programmed to external oscillator, and no external SYNC signal is present, the LTC3889 PWM engine will run at the lowest free running frequency of the PLL oscillator. This may result in excess inductor current and undesirable operation. If multiple parts share the SYNC signal and the external SYNC signal is not present, the parts will not be synchronized and excess voltage ripple on the output may be present.

Multiple LTC3889s are required to share one SYNC signal in PolyPhase configurations, for other configurations connecting the SYNC pins to form a single SYNC signal is optional. If the SYNC pin is shared between LTC3889s, only one LTC3889 should be programmed with a frequency output. All the other LTC3889s should be programmed to disable their SYNC output. However their frequency should be programmed to the nominal desired value. If the LTC3889 is programmed with a frequency output, and an external signal is present. Bit 10 of MFR_PADS will be asserted low if this condition exists.

If the PWM signal appears to be running at too high a frequency, monitor the SYNC pin. Extra transitions on the falling edge will result in the PLL trying to lock on to noise versus the intended signal. Review routing of digital control signals and minimize crosstalk to the SYNC signal to avoid this problem.

MINIMUM ON-TIME CONSIDERATIONS

Minimum on-time, $t_{\text{ON(MIN)}}$, is the smallest time duration that the LTC3889 is capable of turning on the top MOSFET. It is determined by internal timing delays and the gate charge required to turn off the top MOSFET. Low duty cycle applications may approach this minimum on-time limit and care should be taken to ensure that:

$$t_{\text{ON(MIN)}} < \frac{V_{\text{OUT}}}{V_{\text{IN}} \cdot f_{\text{OSC}}}$$

If the duty cycle falls below what can be accommodated by the minimum on-time, the controller will begin to skip cycles. The output voltage will continue to be regulated, but the ripple voltage and current will increase.

The minimum on-time for the LTC3889 is approximately 45ns. Good PCB layout, minimum 30% inductor current ripple and at least 10mV to 15mV ripple on the current sense signal are required to avoid increasing the minimum on-time. The minimum on-time can be affected by PCB switching noise in the voltage and current loop. As the peak current sense voltage decreases, the minimum on-time gradually increases to 130ns. This is of particular concern in forced continuous applications with low ripple current at light loads. If the duty cycle drops below the minimum on-time limit in this situation, a significant amount of cycle skipping can occur with correspondingly larger current and voltage ripple.

EXTERNAL TEMPERATURE SENSE

The LTC3889 is capable of measuring the temperature of the power stage temperature of each channel. Multiple methods using silicon junction remote sensors are supported. The voltage produced by the remote sense circuit is digitized by the internal ADC, and the computed temperature value is returned by the paged READ_TEMPERATURE_1 telemetry command.

The most accurate external temperature measurement can be made using a diode-connected PNP transistor such as the MMBT3906 as shown in Figure 32. Bit 5 of MFR_PWM_MODE_LTC3889 should be set to 0 (ΔV_{BE} method) when using this sensor configuration. The transistor should be placed in contact with or immediately adjacent to the power stage inductor. Its emitter should be connected to the TSNS $_n$ pin while the base and collector terminals of the PNP transistor must be connected

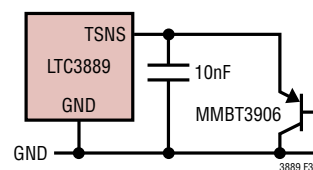

Figure 32. External ΔV_{BE} Temperature Sense

APPLICATIONS INFORMATION

and returned directly to Pin 53 of the LTC3889 using a Kelvin connection. For best noise immunity, the connections should be routed differentially and a 10nF capacitor should be placed in parallel with the diode-connected PNP. Parasitic PCB trace inductance between the capacitor and transistor should be minimized. Avoid placing PCB vias between the transistor and capacitor.

The LTC3889 also supports direct junction voltage measurements when bit 5 of MFR_PWM_MODE_LTC3889 is set to one. The factory defaults support a resistor-trimmed dual diode network as shown in Figure 33. This second measurement method is not generally as accurate as the first, but it supports legacy power blocks or may prove necessary if high noise environments prevent use of the ΔV_{BE} approach with its lower signal levels.

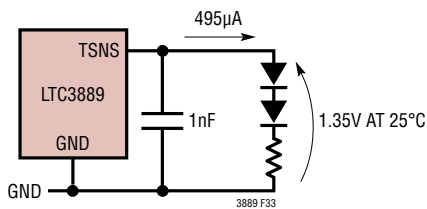

Figure 33. 2D+R Temperature Sense

For either method, the slope of the external temperature sensor can be modified with the coefficient stored in MFR_TEMP_1_GAIN. With the ΔV_{BE} approach, typical PNPs require temperature slope adjustments slightly less than 1. The MMBT3906 has a recommended value of approximately MFR_TEMP_1_GAIN = 0.991 based on the ideality factor of 1.01. Simply invert the ideality factor to calculate the MFR_TEMP_1_GAIN. Different manufacturers and different lots may have different ideality factors. Consult with the manufacturer to set this value. Characterization over temperature of a prototype or prototypes is recommended before selecting a final MFR_TEMP_1_GAIN value when using the direct p-n junction measurement method.

The offset of the external temperature sense can be adjusted using MFR_TEMP_1_OFFSET.

If an external temperature sense element is not used, the TSNS_npin must be shorted to GND. The UT_FAULT_LIMIT must be set to -275°C , the UT_FAULT_RESPONSE must be set to ignore, and the IOUT_CAL_GAIN_TC to a value of 0.

To ensure proper use of these temperature adjustment parameters, refer to the specific formulas given for the two methods in the MFR_PWM_MODE_LTC3889 command section.

Derating EEPROM Retention at Temperature

EEPROM read operations between -40°C and 125°C will not affect data storage. But retention will be degraded if the EEPROM is written above 85°C or stored or operated above 125°C . If an occasional fault log is generated above 85°C , the slight reduction in data retention in the EEPROM fault log area will not affect the use of the function or other EEPROM storage. See the Operation section for other high temperature EEPROM functional details. Degradation in data can be approximated by calculating the dimensionless acceleration factor using the following equation.

$$AF = e^{-\left[\left(\frac{E_a}{k}\right) \cdot \left(\frac{1}{T_{USE}+273} - \frac{1}{T_{STRESS}+273}\right)\right]}$$

where:

AF = acceleration factor

E_a = activation energy = 1.4eV

$k = 8.617 \cdot 10^{-5} \text{ eV}/^{\circ}\text{K}$

T_{USE} = is the specified junction temperature

T_{STRESS} = actual junction temperature in $^{\circ}\text{C}$

As an example, if the device is stored at 130°C for 10 hours,

$T_{STRESS} = 130^{\circ}\text{C}$, and

$$AF = e^{-\left[\left(\frac{1.4}{8.617 \cdot 10^{-5}}\right) \cdot \left(\frac{1}{398} - \frac{1}{403}\right)\right]} = 1.66$$

indicating the effect is the same as operating the device at 125°C for $10 \cdot 1.66 = 16.6$ hours, resulting in a retention derating of 6.6 hours.

APPLICATIONS INFORMATION

INPUT CURRENT SENSE AMPLIFIER

The LTC3889 input current sense amplifier can sense the supply current into the V_{IN} pin using an external resistor as well as the power stage current using an external sense resistor. Unless care is taken to mitigate the frequency noise caused by the discontinuous input current, significant input current measurement error may occur. The noise will be the greatest in high current applications and at large step-down ratios. Careful layout and filtering at the V_{IN} pin is recommended to minimize measurement error. The V_{IN} pin should be filtered with a resistor and a ceramic capacitor. The filter should be located as close to the V_{IN} pin as possible. The supply side of the V_{IN} pin filter should be Kelvin connected to the supply side of the R_{IINSNS} resistor. A 2 Ω resistor should be sufficient for most applications. The resistor will cause an IR voltage drop from the supply to the V_{IN} pin due to the current flowing into the V_{IN} pin. To compensate for this voltage drop, the MFR_RVIN command value should be set to the nominal resistor value. The LTC3889 will multiply the MFR_READ_ICHIP measurement value by the user defined MFR_RVIN value and add this voltage to the measured voltage at the V_{IN} pin.

$$READ_VIN = V_{VIN_PIN} + (MFR_READ_ICHIP \cdot MFR_RVIN)$$

Therefore, the READ_VIN command will return the value of the voltage at the supply side of the V_{IN} pin filter. If no V_{IN} filter element is used, set MFR_RVIN = 0.

An RC filter of 1k Ω and 10nF capacitors from the I_{IN+} and I_{IN-} pins to the V_{IN} pin may be required at higher input voltage levels. The capacitor from the drain of the topside MOSFET to ground should be a low ESR ceramic capacitor. It should be placed as close as possible to the drain of the topside MOSFET to supply high frequency

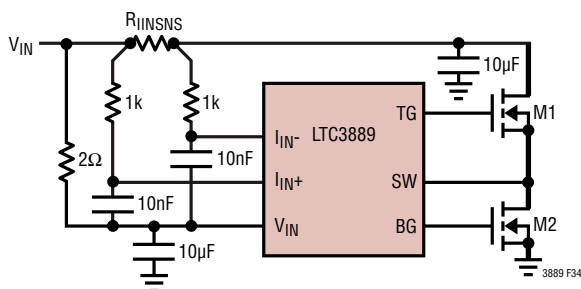

Figure 34. Low Noise Input Current Sense Circuit

transient input current. This will help prevent noise from the top gate MOSFET from feeding into the input current sense amplifier inputs and supply.

If the input current sense amplifier is not used, short the V_{IN} , I_{IN+} and I_{IN-} and pins together.

EXTERNAL RESISTOR CONFIGURATION PINS (RCONFIG)

The LTC3889 is factory programmed to use external resistor configuration. This allows output voltage, PWM frequency, PWM phasing, and the PMBus address to be set by the user without programming the part through the PMBus interface or purchasing custom programmed parts. To use resistor programming, the RCONFIG pin(s) require a resistor divider between V_{DD25} and GND. The RCONFIG pins are only interrogated at initial power up and during a reset, so modifying their values on the fly while the part is powered will have no effect. RCONFIG pins on the same IC can be shared with a single resistor divider if they require identical programming. Resistors with a tolerance of 1% or better must be used to assure proper operation. In the following tables, R_{TOP} is connected between V_{DD25} and the RCONFIG pin while R_{BOT} is connected between the pin and GND. Noisy clock signals should not be routed near these pins.

Voltage Selection

When an output voltage is set using the VOUT_CFGn pins the following parameters are set as a percentage of the output voltage:

- VOUT_OV_FAULT_LIMIT +10%
- VOUT_OV_WARN_LIMIT +7.5%
- VOUT_MAX +7.5%
- VOUT_MARGIN_HIGH +5%
- VOUT_MARGIN_LOW -5%
- VOUT_UV_WARN_LIMIT -6.5%
- VOUT_UV_FAULT_LIMIT -7%

Refer to Table 3 to set the output voltage using the VOUT_CFGn pins. 1% resistors must be used to assure proper operation. If VOUT is set to 7V or lower, low range is used.

APPLICATIONS INFORMATION

When V_{OUT} is set using the $V_{OUT}n_CFG$ pins, the part will turn on the rail modifying the ON_OFF_CONFIG command, if required, to respond to PMBus commands.

Table 3. $V_{OUT_CFG}n$

| R_{TOP} (k Ω) | R_{BOTTOM} (k Ω) | V_{OUT} (V) | ON/OFF |
|-------------------------|----------------------------|---------------|--------|
| 0 or Open | Open | EEPROM | EEPROM |
| 10 | 23.2 | 36 | ON |
| 10 | 15.8 | 28 | ON |
| 16.2 | 20.5 | 24 | ON |
| 16.2 | 17.4 | 18 | ON |
| 20 | 17.8 | 15 | ON |
| 20 | 15 | 12 | ON |
| 20 | 12.7 | 8 | ON |
| 20 | 11 | 7 | ON |
| 24.9 | 11.3 | 5 | ON |
| 24.9 | 9.09 | 3.3 | ON |
| 24.9 | 7.32 | 2.5 | ON |
| 24.9 | 5.76 | 1.8 | ON |
| 24.9 | 4.32 | 1.5 | ON |
| 30.1 | 3.57 | 1.2 | ON |
| 30.1 | 1.96 | 1 | ON |
| Open | 0 | EEPROM | OFF |

Frequency Selection

The PWM switching frequency is set according to Table 4. The SYNC pins must be shared in poly-phase configurations where multiple LTC3889s or multiple LTC3889s and LTC3870s are used to produce the output. If the configuration is not PolyPhase the SYNC pins do not have to be shared. If the SYNC pins are shared between LTC3889s only one SYNC pin should be enabled, all other SYNC pins should be disabled. A pull-up resistor to V_{DD33} is required on the SYNC pin.

For example in a 4-phase configuration clocked at 250kHz, all of the LTC3889s must be set to the desired frequency and phase and one LTC3889 should be set to the desired frequency with the SYNC pin disabled. All phasing is with respect to the falling edge of SYNC.

For LTC3889 chip 1, set the frequency to 250kHz with 90° and 270° phase shift with the SYNC pin enabled:

Frequency: $R_{TOP} = 24.9k\Omega$ and $R_{BOT} = 9.09k\Omega$

Phase: $R_{TOP} = 30.1k\Omega$ and $R_{BOT} = 1.96k\Omega$

For LTC3889 chip 2, set the frequency to 250kHz with 0° and 180° phase shift and the SYNC pin disabled:

Frequency: $R_{TOP} = 24.9k\Omega$ and $R_{BOT} = 9.09k\Omega$

Phase: $R_{TOP} = 24.9k\Omega$ and $R_{BOT} = 11.3k\Omega$

All configurations in frequency and phase can be achieved using the $FREQ_CFG$ and $PHAS_CFG$ pins. In the above application, if the SYNC pin connection is lost from chip 1, chip 2 will internally detect the frequency as missing and continue switching at 250kHz. However, because the SYNC pin is disconnected between the chips, the output voltage ripple will likely be higher than desired. Bit 10 of MFR_PADS will assert low on chip 2 indicating chip 2 is providing its own internal oscillator when it is expecting an external SYNC input.

Table 4. $FREQ_CFG$ Resistor Programming

| R_{TOP} (k Ω) | R_{BOT} (k Ω) | SWITCHING FREQUENCY (kHz) |
|-------------------------|-------------------------|---------------------------|
| 0 or Open | Open | EEPROM |
| 10 | 23.2 | EEPROM |
| 10 | 15.8 | EEPROM |
| 16.2 | 20.5 | EEPROM |
| 16.2 | 17.4 | EEPROM |
| 20 | 17.8 | 500 |
| 20 | 15 | 425 |
| 20 | 12.7 | 350 |
| 20 | 11 | 300 |
| 24.9 | 11.3 | 275 |
| 24.9 | 9.09 | 250 |
| 24.9 | 7.32 | 200 |
| 24.9 | 5.76 | 150 |
| 24.9 | 4.32 | 125 |
| 30.1 | 3.57 | 100 |
| 30.1 | 1.96 | 85 |
| Open | 0 | External SYNC Only |

APPLICATIONS INFORMATION

Phase Selection

The phase of the channels with respect to the falling edge of SYNC is set using the values in Table 5.

Table 5. PHAS_CFG Resistor Programming

| R _{TOP} (kΩ) | R _{BOT} (kΩ) | θ _{SYNC TO θ₀} | θ _{SYNC TO θ₁} | SYNC OUTPUT |
|-----------------------|-----------------------|------------------------------------|------------------------------------|-------------|
| 0 or Open | Open | EEPROM | EEPROM | EEPROM |
| 10 | 23.2 | EEPROM | EEPROM | EEPROM |
| 10 | 15.8 | EEPROM | EEPROM | EEPROM |
| 16.2 | 20.5 | 120° | 300° | DISABLED |
| 16.2 | 17.4 | 60° | 240° | |
| 20 | 12.7 | 120° | 240° | |
| 20 | 15 | 0° | 120° | |
| 20 | 12.7 | 0° | 240° | |
| 20 | 11 | 90° | 270° | |
| 24.9 | 11.3 | 0° | 180° | |
| 24.9 | 9.09 | 120° | 300° | |
| 24.9 | 7.32 | 60° | 240° | |
| 24.9 | 5.76 | 120° | 240° | |
| 24.9 | 4.32 | 0° | 120° | ENABLED |
| 30.1 | 3.57 | 0° | 240° | |
| 30.1 | 1.96 | 90° | 270° | |
| Open | 0 | 0° | 180° | |

Address Selection Using RCONFIG

The LTC3889 address is selected based on the programming of the two configuration pins ASELO and ASEL1 according to Table 6. ASELO programs the bottom four bits of the device address for the LTC3889, and ASEL1 programs the three most-significant bits. Either portion of the address can also be retrieved from the MFR_ADDRESS value in EEPROM. If both pins are left open, the full 7-bit MFR_ADDRESS value stored in EEPROM is used to determine the device address. The LTC3889 always responds to 7-bit global addresses 0x5A and 0x5B. MFR_ADDRESS should not be set to either of these values because these are global addresses and all parts will respond to them.

Table 6. ASEL₁ Resistor Programming

| R _{TOP} (kΩ) | R _{BOT} (kΩ) | ASEL1 | | ASELO | | | |
|-----------------------|-----------------------|----------------------------------|-----|----------------------------------|-----|------|---|
| | | LTC3889 DEVICE ADDRESS BITS[6:4] | | LTC3889 DEVICE ADDRESS BITS[3:0] | | | |
| | | BINARY | HEX | BINARY | HEX | | |
| 0 or Open | Open | EEPROM | | EEPROM | | | |
| 10 | 23.2 | EEPROM | | 1111 | F | | |
| 10 | 15.8 | | | 1110 | E | | |
| 16.2 | 20.5 | | | 1101 | D | | |
| 16.2 | 17.4 | | | 1100 | C | | |
| 20 | 17.8 | | | 1011 | B | | |
| 20 | 15 | | | 1010 | A | | |
| 20 | 12.7 | | | 1001 | 9 | | |
| 20 | 11 | | | 1000 | 8 | | |
| 24.9 | 11.3 | | | 111 | 7 | 0111 | 7 |
| 24.9 | 9.09 | | | 110 | 6 | 0110 | 6 |
| 24.9 | 7.32 | 101 | 5 | 0101 | 5 | | |
| 24.9 | 5.76 | 100 | 4 | 0100 | 4 | | |
| 24.9 | 4.32 | 011 | 3 | 0011 | 3 | | |
| 30.1 | 3.57 | 010 | 2 | 0010 | 2 | | |
| 30.1 | 1.96 | 001 | 1 | 0001 | 1 | | |
| Open | 0 | 000 | 0 | 0000 | 0 | | |

EFFICIENCY CONSIDERATIONS

The percent efficiency of a switching regulator is equal to the output power divided by the input power times 100%. It is often useful to analyze individual losses to determine what is limiting the efficiency and which change would produce the most improvement. Percent efficiency can be expressed as:

$$\% \text{Efficiency} = 100\% - (L1 + L2 + L3 + \dots)$$

where L1, L2, etc. are the individual losses as a percentage of input power.

APPLICATIONS INFORMATION

Although all dissipative elements in the circuit produce losses, four main sources usually account for most of the losses in LTC3889 circuits: 1) IC V_{IN} current, 2) DRV_{CC} regulator current, 3) I^2R losses, 4) Topside MOSFET transition losses.

1. The V_{IN} current is the DC supply current given in the Electrical Characteristics table, which excludes MOSFET driver and control currents. Supplying the DRV_{CC} current from the $EXTV_{CC}$ pin with an external supply will reduce the V_{IN} current required to a minimum.
2. DRV_{CC} current is the sum of the MOSFET driver and control currents. The MOSFET driver current results from switching the gate capacitance of the power MOSFETs. Each time a MOSFET gate is switched from low to high to low again, a packet of charge dQ moves from DRV_{CC} to ground. The resulting dQ/dt is a current out of DRV_{CC} that is typically much larger than the control circuit current. In continuous mode, $I_{GATECHG} = f(Q_T + Q_B)$, where Q_T and Q_B are the gate charges of the topside and bottom side MOSFETs.
3. I^2R losses are predicted from the DC resistances of the fuse (if used), MOSFET, inductor and current sense resistor. In continuous mode, the average output current flows through L and R_{SENSE} , but is “chopped” between the topside MOSFET and the synchronous MOSFET. If the two MOSFETs have approximately the same $R_{DS(ON)}$, then the resistance of one MOSFET can simply be summed with the resistances of L and R_{SENSE} to obtain I^2R losses. For example, if each $R_{DS(ON)} = 10m\Omega$, $R_L = 10m\Omega$, $R_{SENSE} = 5m\Omega$, then the total resistance is $25m\Omega$. This results in losses ranging from 2% to 8% as the output current increases from 3A to 15A for a 5V output, or a 3% to 12% loss for a 3.3V output. Efficiency varies as the inverse square of V_{OUT} for the same external components and output power level. The combined effects of increasingly lower output voltages and higher currents required by high performance digital systems is not doubling but quadrupling the importance of loss terms in the switching regulator system!

4. Transition losses apply only to the topside MOSFET(s), and become significant only when operating at high input voltages (typically 15V or greater). Transition losses can be estimated from:

$$\text{Transition Loss} = (1.7) V_{IN}^2 I_{O(MAX)} C_{RSS} f$$

Other “hidden” losses such as copper trace and internal battery resistances can account for an additional 5% to 10% efficiency degradation in portable systems. It is very important to include these “system” level losses during the design phase. The internal battery and fuse resistance losses can be minimized by making sure that C_{IN} has adequate charge storage and very low ESR at the switching frequency. A 25W supply will typically require a minimum of $20\mu F$ to $40\mu F$ of capacitance having a maximum of $20m\Omega$ to $50m\Omega$ of ESR. The LTC3889 2-phase architecture typically halves this input capacitance requirement over competing solutions. Other losses including Schottky conduction losses during dead time and inductor core losses generally account for less than 2% total additional loss.

PROGRAMMABLE LOOP COMPENSATION

The LTC3889 offers programmable loop compensation to optimize the transient response without any hardware change. As shown in Figure 35, the error amplifier gain g_m varies from $1.0mmho$ to $5.73mmho$, and the compensation resistor R_{TH} varies from $0k\Omega$ to $62k\Omega$ inside the controller. Two compensation capacitors, C_{TH} and C_{THP} , are required in the design and the typical ratio between C_{TH} and C_{THP} is 10.

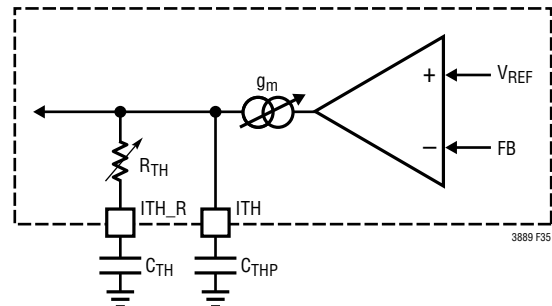

Figure 35. Programmable Loop Compensation

APPLICATIONS INFORMATION

By adjusting the g_m and R_{TH} only, the LTC3889 can provide a flexible type II compensation network to optimize the loop over a wide range of output capacitors. Adjusting the g_m will change the gain of the compensation over the whole frequency range without moving the pole and zero location, as shown in Figure 36.

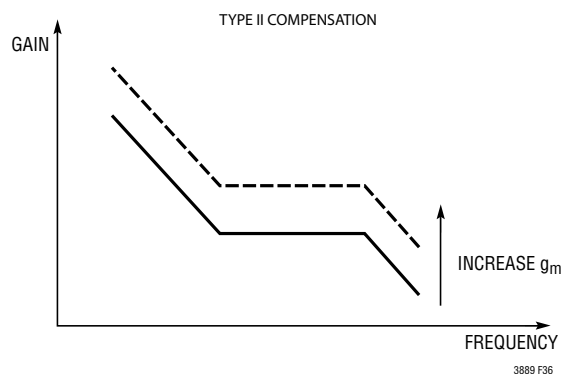

Figure 36. Error Amp g_m Adjust

Adjusting the R_{TH} will change the pole and zero location, as shown in Figure 37. It is recommended that the user determines the appropriate value for the g_m and R_{TH} using the LTPowerCADtool.

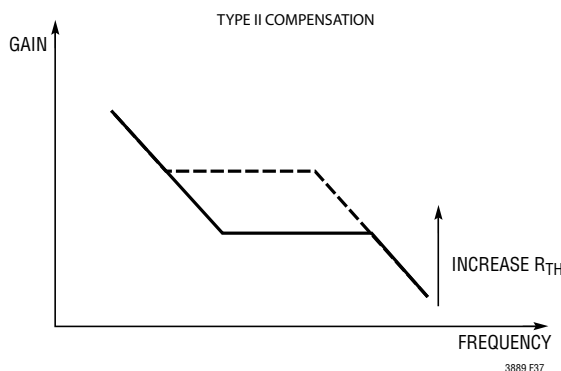

Figure 37. R_{TH} Adjust

CHECKING TRANSIENT RESPONSE

The regulator loop response can be checked by looking at the load current transient response. Switching regulators take several cycles to respond to a step in DC (resistive) load current. When a load step occurs, V_{OUT} shifts by an amount equal to ΔI_{LOAD} (ESR), where ESR is the effective series resistance of C_{OUT} . ΔI_{LOAD} also begins to charge or discharge C_{OUT} generating the feedback error signal that forces the regulator to adapt to the current change and

return V_{OUT} to its steady-state value. During this recovery time V_{OUT} can be monitored for excessive overshoot or ringing, which would indicate a stability problem. The availability of the I_{TH} pin not only allows optimization of control loop behavior but also provides a DC-coupled and AC-filtered closed-loop response test point. The DC step, rise time and settling at this test point truly reflects the closed-loop response. Assuming a predominantly second order system, phase margin and/or damping factor can be estimated using the percentage of overshoot seen at this pin. The bandwidth can also be estimated by examining the rise time at the pin. The I_{THR} external capacitor shown in the Typical Application circuit will provide an adequate starting point for most applications. The programmable parameters that affect loop gain are the voltage range, bit[1] of the MFR_PWM_CONFIG_LTC3889 command, the current range, bit 7 of the MFR_PWM_MODE_LTC3889 command, the g_m of the PWM channel amplifier, bits [7:5] of MFR_PWM_COMP, and the internal R_{ITH} compensation resistor, bits[4:0] of MFR_PWM_COMP. Be sure to establish these settings prior to compensation calculation.

The I_{TH} series internal R_{ITH} - external C_C filter sets the dominant pole-zero loop compensation. The internal R_{ITH} value can be modified (from 0Ω to $62k\Omega$) using bits[4:0] of the MFR_PWM_COMP command. Adjust the value of R_{ITH} to optimize transient response once the final PC layout is done and the particular C_C filter capacitor and output capacitor type and value have been determined. The output capacitors need to be selected because the various types and values determine the loop gain and phase. An output current pulse of 20% to 80% of full-load current having a rise time of $1\mu s$ to $10\mu s$ will produce output voltage and I_{TH} pin waveforms that will give a sense of the overall loop stability without breaking the feedback loop. Placing a power MOSFET with a resistor to ground directly across the output capacitor and driving the gate with an appropriate signal generator is a practical way to produce a load step. The MOSFET + R_{SERIES} will produce output currents approximately equal to V_{OUT}/R_{SERIES} . R_{SERIES} values from 0.1Ω to 2Ω are valid depending on the current limit settings and the programmed output voltage. The initial output voltage step resulting from the step change in output current may not be within the bandwidth of the

APPLICATIONS INFORMATION

feedback loop, so this signal cannot be used to determine phase margin. This is why it is better to look at the I_{TH} pin signal which is in the feedback loop and is the filtered and compensated control loop response. The gain of the loop will be increased by increasing R_{ITH} and the bandwidth of the loop will be increased by decreasing C_C . If R_{ITH} is increased by the same factor that C_C is decreased, the zero frequency will be kept the same, thereby keeping the phase shift the same in the most critical frequency range of the feedback loop. The gain of the loop will be proportional to the transconductance of the error amplifier which is set using bits[7:5] of the `MFR_PWM_COMP` command. The output voltage settling behavior is related to the stability of the closed-loop system and will demonstrate the actual overall supply performance.

A second, more severe transient is caused by switching in loads with large ($>1\mu\text{F}$) supply bypass capacitors. The discharged bypass capacitors are effectively put in parallel with C_{OUT} , causing a rapid drop in V_{OUT} . No regulator can alter its delivery of current quickly enough to prevent this sudden step change in output voltage if the load switch resistance is low and it is driven quickly. If the ratio of

C_{LOAD} to C_{OUT} is greater than 1:50, the switch rise time should be controlled so that the load rise time is limited to approximately $25 \cdot C_{LOAD}$. Thus a $10\mu\text{F}$ capacitor would require a $250\mu\text{s}$ rise time, limiting the charging current to about 200mA.

PolyPhase CONFIGURATION

When configuring a PolyPhase rail with multiple LTC3889s, the user must share the `SYNC`, `ITH`, `SHARE_CLK`, `FAULT \bar{n}` , `PGOOD n` and `ALERT \bar{n}` pins of both parts. Be sure to use pull-up resistors on `FAULT n` , `PGOOD n` , `SYNC`, `SHARE_CLK` and `ALERT \bar{n}` . One of the LTC3889's `SYNC` pin must be set to the desired switching frequency, and all other `FREQUENCY_SWITCH` commands must be set to External Clock. If an external oscillator is provided, set the `FREQUENCY_SWITCH` command to External Clock for all LTC3889s. The relative phasing of all the channels should be spaced equally. The `MFR_RAIL_ADDRESS` of all the devices should be set to the same value.

When connecting a PolyPhase rail with LTC3889s, connect the V_{IN} pins of the LTC3889s directly back to the supply voltage through the V_{IN} pin filter networks.

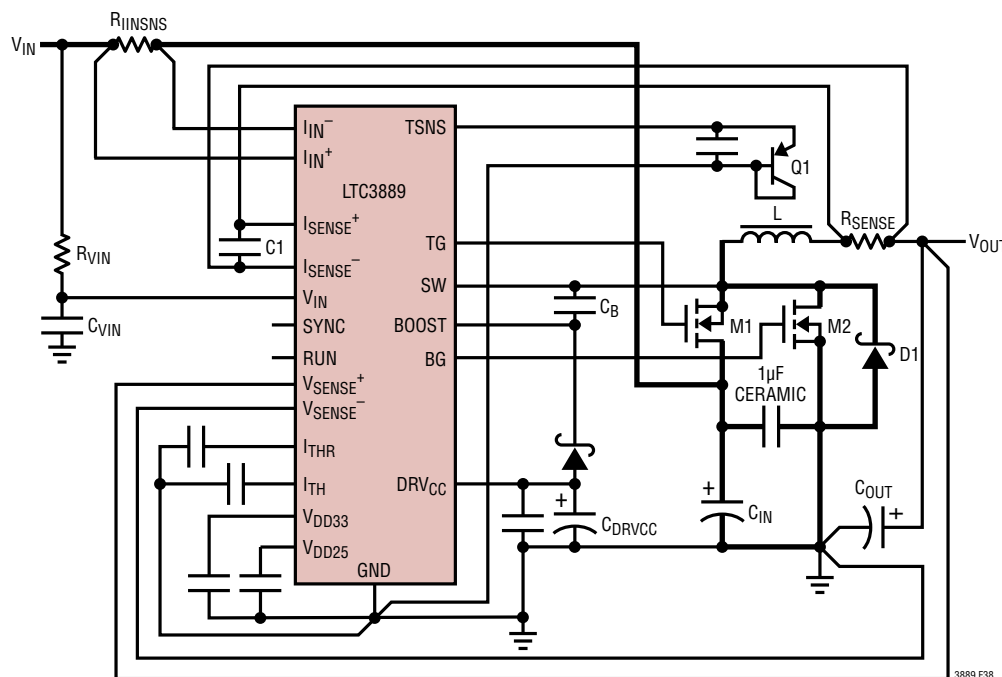

Figure 38. Recommended Printed Circuit Layout Diagram, Single Phase Shown

APPLICATIONS INFORMATION

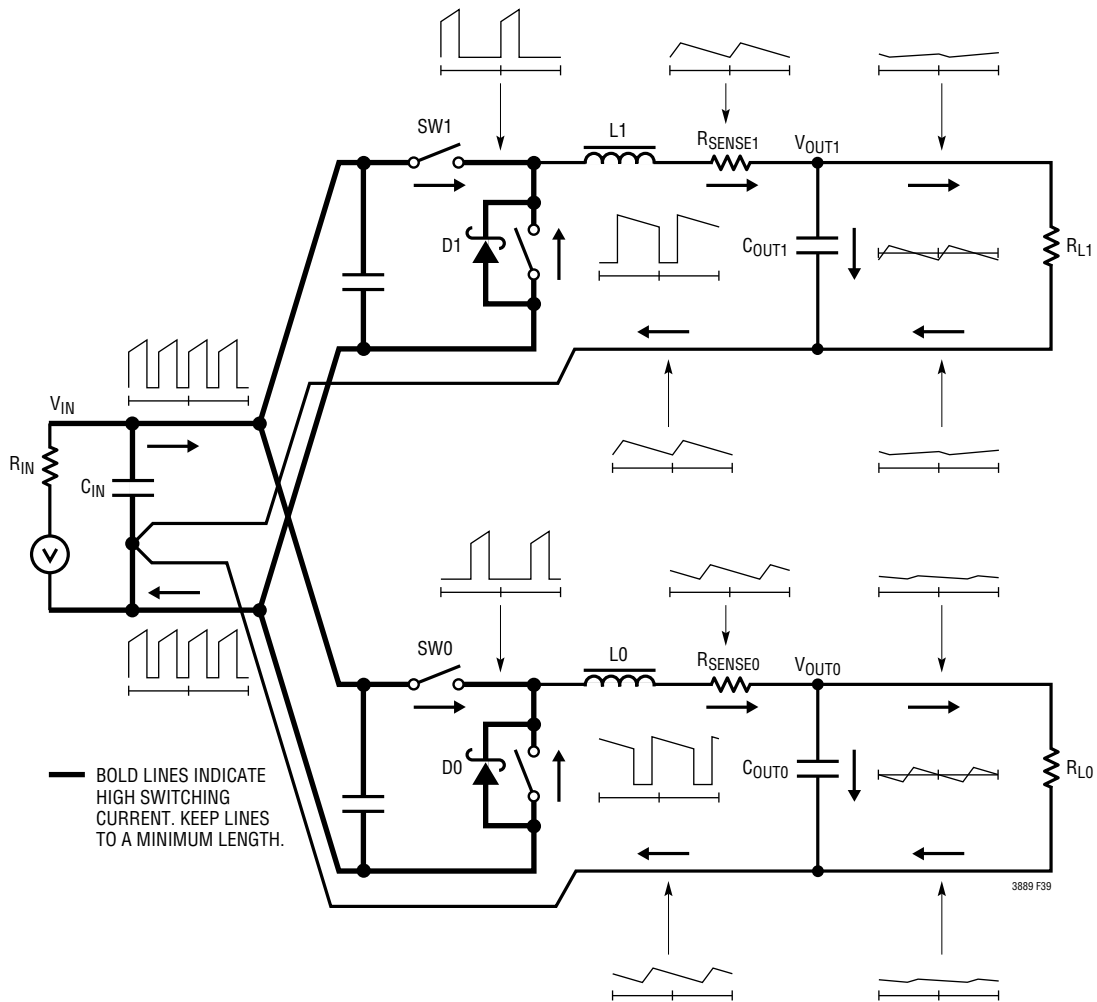

Figure 39. Branch Current Waveforms

APPLICATIONS INFORMATION

PC BOARD LAYOUT CHECKLIST

When laying out the printed circuit board, the following checklist should be used to ensure proper operation of the IC. These items are also illustrated graphically in the layout diagram of Figure 38. Figure 39 illustrates the current waveforms present in the various branches of the synchronous regulator operating in the continuous mode. Check the following in your layout:

1. Is the top N-channel MOSFET, M1, located within 1cm of C_{IN} ?
2. Are signal ground and power ground kept separate? The ground return of C_{DRVCC} must return to the combined C_{OUT} (-) terminals.
3. The I_{TH} trace should be as short as possible.
4. The loop formed by the top N-channel MOSFET, Schottky diode and the C_{IN} capacitor should have short leads and PC trace lengths.
5. The output capacitor (-) terminals should be connected as close as possible to the (-) terminals of the input capacitor by placing the capacitors next to each other and away from the Schottky loop described in item 4.
6. Are the I_{SENSE}^+ and I_{SENSE}^- leads routed together with minimum PC trace spacing? The filter capacitor between I_{SENSE}^+ and I_{SENSE}^- should be as close as possible to the IC. Ensure accurate current sensing with Kelvin connections at the sense resistor or inductor, whichever is used for current sensing.
7. Is the DRV_{CC} decoupling capacitor connected close to the IC, between the DRV_{CC} and the power ground pins? This capacitor carries the MOSFET driver current peaks. An additional $1\mu F$ ceramic capacitor placed immediately next to the DRV_{CC} and GND pins can help improve noise performance substantially.
8. Keep the switching nodes (SW_n), top gate nodes (TG_n), and boost nodes ($BOOST_n$) away from sensitive small-signal nodes, especially from the voltage and current sensing feedback pins. All of these nodes have very large and fast moving signals and therefore should be kept on the “output side” of the LTC3889 and occupy minimum PC trace area. If DCR sensing is used, place the top resistor (Figure 25a, R1) close to the switching node.
9. Use a modified “star ground” technique: a low impedance, large copper area central grounding point on the same side of the PC board as the input and output capacitors with tie-ins for the bottom of the DRV_{CC} and $EXTV_{CC}$ decoupling capacitors, the bottom of the voltage feedback resistive divider and the GND pin of the IC.
10. Are the I_{IN}^+ and I_{IN}^- pins Kelvin connected to the $R_{SENSEIN}$ sense resistor? This will prevent the PCB trace resistance from causing errors in the input current measurement. These traces should be as short as possible and routed away from any noisy nodes such as the switching or boost nodes.
11. Is the V_{IN} filter Kelvin connected to the input side of the $R_{SENSEIN}$ resistor? This can help improve the noise performance of the input current sense amplifier by reducing the voltage transients between the amplifier inputs and amplifier supply caused by the discontinuous power stage current.

PC BOARD LAYOUT DEBUGGING

It is helpful to use a DC-50MHz current probe to monitor the current in the inductor while testing the circuit. Monitor the output switching node (SW_n pin) to synchronize the oscilloscope to the internal oscillator and probe the actual output voltage as well. Check for proper performance over the operating voltage and current range expected in the application. The frequency of operation should be maintained over the input voltage range down to dropout and until the output load drops below the low current operation threshold.

The duty cycle percentage should be maintained from cycle to cycle in a well-designed, low noise PCB implementation. Variation in the duty cycle at a subharmonic rate can suggest noise pickup at the current or voltage sensing inputs or inadequate loop compensation. Overcompensation of the loop can be used to tame a poor PC layout if regulator bandwidth optimization is not required.

APPLICATIONS INFORMATION

Reduce V_{IN} from its nominal level to verify operation of the regulator in dropout. Check the operation of the undervoltage lockout circuit by further lowering V_{IN} while monitoring the outputs to verify operation.

Investigate whether any problems exist only at higher output currents or only at higher input voltages. If problems coincide with high input voltages and low output currents, look for capacitive coupling between the $BOOSTn$, SWn , TGn , and possibly BGn connections and the sensitive voltage and current pins. The capacitor placed across

the current sensing pins needs to be placed immediately adjacent to the pins of the IC. This capacitor helps to minimize the effects of differential noise injection due to high frequency capacitive coupling. If problems are encountered with high current output loading at lower input voltages, look for inductive coupling between C_{IN} , Schottky and the top MOSFET components to the sensitive current and voltage sensing traces. In addition, investigate common ground path voltage pickup between these components and the GND pin of the IC.

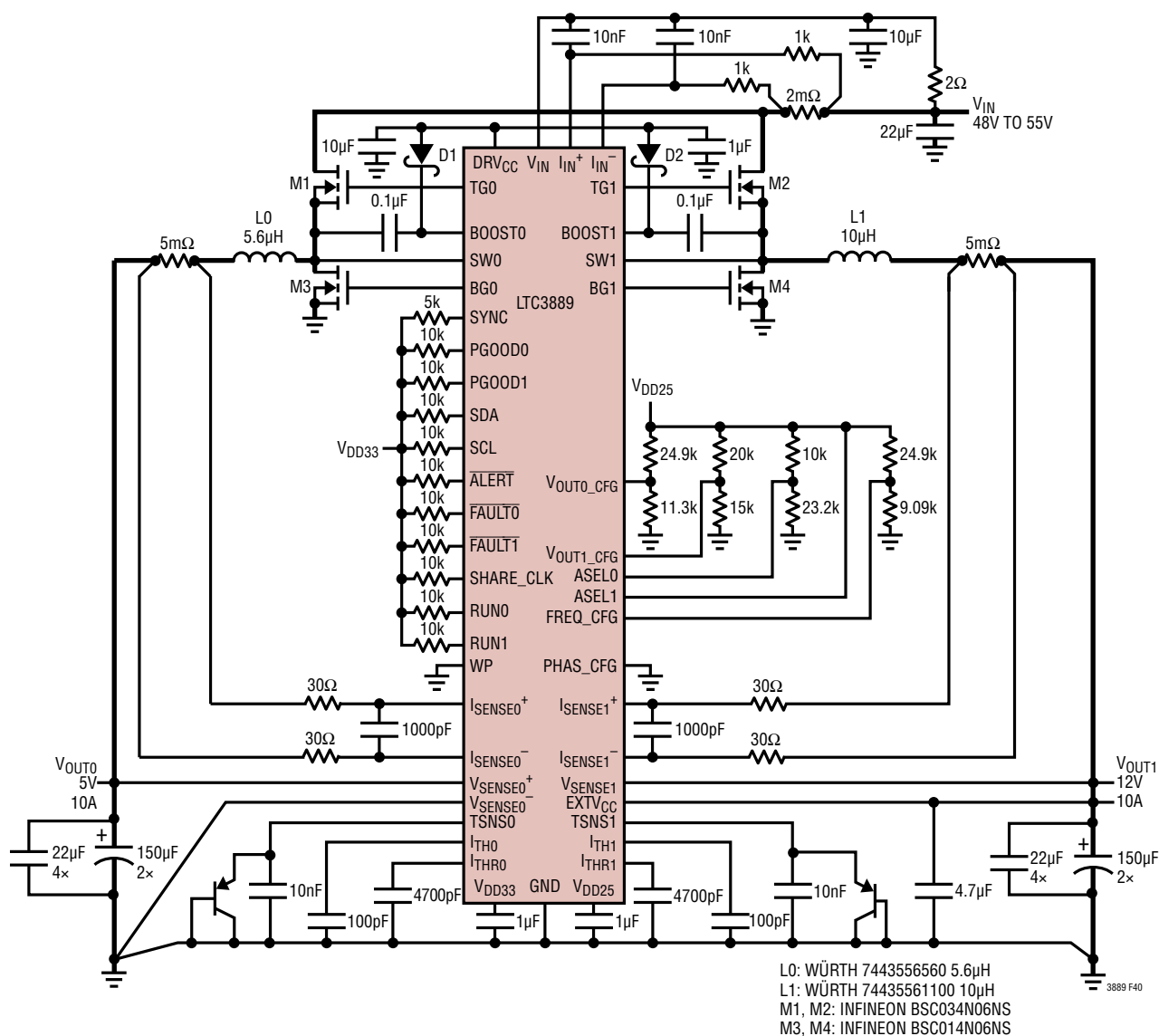

Figure 40. High Efficiency Dual 250kHz 12V/5V Step-Down Converter

APPLICATIONS INFORMATION

DESIGN EXAMPLE

As a design example for a medium current regulator, assume $V_{IN} = 48V$ nominal, $V_{IN} = 55V$ maximum, $V_{OUT0} = 3.3V$, $V_{OUT1} = 12V$, $I_{MAX0,1} = 10A$ and $f = 250kHz$ (see Figure 40).

The regulated outputs are established by the $V_{OUT_COMMAND}$ stored in EEPROM or placing the following resistor divider between V_{DD25} the V_{OUTn_CFG} pin and GND:

1. V_{OUT0_CFG} , $R_{TOP} = 24.9k$, $R_{BOTTOM} = 11.3k$
2. V_{OUT1_CFG} , $R_{TOP} = 20k$, $R_{BOTTOM} = 15k$

The frequency and phase are set by EEPROM or by setting the resistor dividers between V_{DD25} and GND.

1. $FREQ_CFG$, $R_{TOP} = 24.9k$, $R_{BOTTOM} = 11.3k$
2. $PHAS_CFG$, $R_{TOP} = \text{Open}$, $R_{BOTTOM} = 0$

The address is set to XF where X is the MSB stored in EEPROM.

The following parameters are set as a percentage of the output voltage if the resistor configuration pins are used to determined output voltage:

- $V_{OUT_OV_FAULT_LIMIT}$ +10%
- $V_{OUT_OV_WARN_LIMIT}$ +7.5%
- V_{OUT_MAX} +7.5%
- $V_{OUT_MARGIN_HIGH}$ +5%
- $V_{OUT_MARGIN_LOW}$ -5%
- $V_{OUT_UV_WARN_LIMIT}$ -6.5%
- $V_{OUT_UV_FAULT_LIMIT}$ -7%

All other user defined parameters must be programmed into the EEPROM. The GUI can be utilized to quickly set up the part with the desired operating parameters.

The inductance values are based on a 35% maximum ripple current assumption (3.5A). The highest value of ripple current occurs at the maximum input voltage:

$$L = \frac{V_{OUT}}{f \cdot \Delta I_{L(MAX)}} \left[1 - \frac{V_{OUT}}{V_{IN(MAX)}} \right]$$

Channel 0 will require $5.2\mu H$ and channel 1 will require $10.7\mu H$. The nearest standard values are $5.6\mu H$ and $10\mu H$ respectively. At the nominal input the ripple will be:

$$\Delta I_{L(NOM)} = \frac{V_{OUT}}{f \cdot L} \left[1 - \frac{V_{OUT}}{V_{IN(NOM)}} \right]$$

Channel 0 will have 3.2A (32%) ripple, and channel 1 will have 3.6A (36%) ripple. The peak inductor current will be the maximum DC value plus one-half the ripple current or 11.6A for channel 0 and 11.8A for channel 1. The minimum on time occurs on channel 0 at the maximum V_{IN} , and should not be less than 45ns:

$$t_{ON(MIN)} = \frac{V_{OUT}}{V_{IN(MAX)} \cdot f} = \frac{5V}{55V(250kHz)} = 363ns$$

The Würth 7443551370 $3.7\mu H$ ($4.9m\Omega$ DCR_{TYP} at $25^\circ C$) channel 0 and the Würth 7443556560 $5.6\mu H$ ($3.7m\Omega$ DCR_{TYP} at $25^\circ C$) channel 1 are the chosen inductors.

The minimum current sense resistor value must be large enough to maintain a 15mV signal.

$$R_{SENSEMIN} = \frac{\Delta V_{ISENSE}}{\Delta I_L} = \frac{15mV}{3.2A} = 4.68m\Omega$$

The maximum current sense resistor value must be small enough to not exceed the 75mV maximum current sense threshold.

$$R_{SENSEMAX} = \frac{V_{IPEAK}}{I_{PEAK}} = \frac{75mV}{11.6A} = 6.46m\Omega$$

Set $R_{SENSE0} = 5m\Omega$

$$I_{OUT_CAL_GAIN} = 5m\Omega$$

Set the respective values for channel 1 to:

$$R_{SENSE0} = 5m\Omega$$

$$I_{OUT_CAL_GAIN} = 5m\Omega$$

$$V_{ILIMIT} = I_{PEAK} \cdot R_{SENSE} = 5mV \cdot 11.6A = 58mV$$

APPLICATIONS INFORMATION

The closest V_{LIMIT} setting is 58.9mV in high range. The values are entered with the `IOUT_OC_FAULT_LIMIT` command. Based on expected variation and measurement in the lab across the sense capacitor the user can determine the optimal setting. For channel 1 the V_{LIMIT} value is 59mV. The closest value is 58.9mV.

The power dissipation on the topside MOSFET can be easily estimated. Choose an INFINEON BSC034N06NS topside MOSFET. $R_{DS(ON)} = 3.4m\Omega$, $C_{MILLER} = 75pF$. At maximum input voltage with T estimated = 50°C and a bottom side INFINEON BSC014N06NS MOSFET, $R_{DS(ON)} = 1.45m\Omega$:

$$P_{MAIN} = \frac{5V}{55V} \cdot (11.6)^2 \cdot [1 + (0.005)(50^\circ C - 25^\circ C)] \\ \cdot 0.0034\Omega + (55V)^2 (5.8A) \cdot \left(\frac{1}{5-2.8} + \frac{1}{2.8} \right) \\ (75pF)(250kHz) = 0.314W$$

The loss in the bottom side MOSFET is:

$$P_{SYNC} = \frac{(55V - 5V)}{55V} \cdot (11.6A)^2 \cdot \\ [1 + (0.005)(50^\circ C - 25^\circ C)] \cdot 0.00145\Omega \\ = 0.2W$$

Both MOSFETS have I^2R losses while the P_{MAIN} equation includes an additional term for transition losses, which are highest at high input voltages.

C_{IN} is chosen for an RMS current rating of:

$$I_{RMS} = \frac{11.6}{55} [(5) \cdot (55 - 5)]^{1/2} = 3.33A$$

at temperature. C_{OUT} is chosen with an ESR of 0.01 Ω for low output ripple. The output ripple in continuous mode will be highest at the maximum input voltage. The output voltage ripple due to ESR is

$$V_{ORIPPLE} = R(\Delta I_L) = 0.01\Omega \cdot 3.2A = 32mV.$$

ADDITIONAL DESIGN CHECKS

Tie `FAULT0` and `FAULT1` together and pull up to V_{DD33} with a 10k resistor.

Tie `RUN0` and `RUN1` together and pull up to V_{DD33} with a 10k resistor.

If there are other ADI PSM parts, connect the `RUN` pins between chips and connect the `FAULT` pins between chips.

Be sure all PMBus pins have resistor pull-up to V_{DD33} and connect these inputs across all ADI PSM parts in the application.

Tie `SHARE_CLK` high with a 10k resistor to V_{DD33} and share between all ADI PSM parts in the application.

Be sure a unique address for each chip can be decoded with the `ASELO` and `ASEL1` pins. Refer to Table 6.

For maximum flexibility, allow board space for R_{TOP} and R_{BOTTOM} for any parameter that is set with resistors such as `ASELO` and `ASEL1`.

CONNECTING THE USB TO I²C/SMBus/PMBus ADAPTER TO THE LTC3889 IN SYSTEM

The ADI USB to I²C/SMBus/PMBus adapter (DC1613A or equivalent) can be interfaced to the LTC3889 on the user's board for programming, telemetry and system debug. The adapter, when used in conjunction with LTpowerPlay, provides a powerful way to debug an entire power system. Faults are quickly diagnosed using telemetry, fault status commands and the fault log. The final configuration can be quickly developed and stored to the LTC3889 EEPROM.

Figure 41 illustrates the application schematic for powering, programming and communication with one or more LTC3889s via the ADI I²C/SMBus/PMBus adapter regardless of whether or not system power is present. If system power is not present, the adapter will power the LTC3889 through the V_{DD33} supply pin. To initialize the part when V_{IN} is not applied and the V_{DD33} pin is powered use global address 0x5B command 0xBD data 0x2B followed by address 0x5B command 0xBD data 0xC4. The LTC3889 will now communicate normally, and the project file can be updated. To write the updated project file to the EEPROM issue a `STORE_USER_ALL` command. When

APPLICATIONS INFORMATION

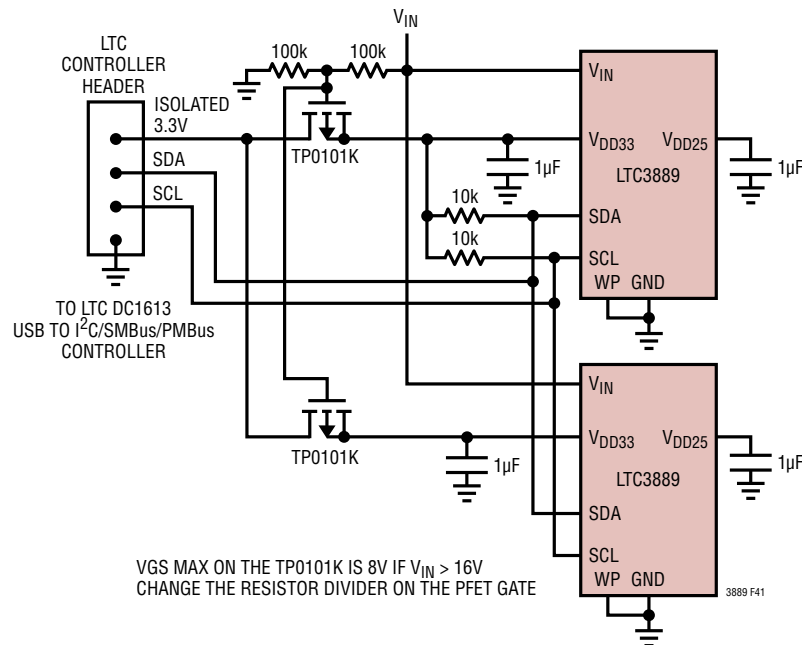

Figure 41. ADI Controller Connection

V_{IN} is applied, a MFR_RESET must be issued to allow the PWM to be enabled and valid ADCs to be read.

Because of the adapter's limited current sourcing capability, only the LTC3889s, their associated pull-up resistors and the I²C pull-up resistors should be powered from the ORed 3.3V supply. In addition any device sharing the I²C bus connections with the LTC3889 should not have body diodes between the SDA/SCL pins and their respective V_{DD} node because this will interfere with bus communication in the absence of system power. If V_{IN} is applied the DC1613A will not supply power to the LTC3889s on the board. It is recommended the RUN n pins be held low or no voltage configuration resistors inserted to avoid providing power to the load until the part is fully configured.

The LTC3889 is fully isolated from the host PC's ground by the DC1613A. The 3.3V from the adapter and the LTC3889 V_{DD33} pin must be driven to each LTC3889 with a separate p-channel MOSFET. If V_{IN} is not applied, the V_{DD33} pins can be in parallel because the on-chip LDO is off. The DC1613A's 3.3V current limit is 100mA but typical V_{DD33} currents are under 15mA. The V_{DD33} does back drive the DRV $_{CC}$ /EXTV $_{CC}$ pins. Normally this is not an issue if V_{IN} is open.

LTpowerPlay: AN INTERACTIVE GUI FOR DIGITAL POWER

LTpowerPlay is a powerful Windows-based development environment that supports Analog Devices digital power ICs including the LTC3889. The software supports a variety of different tasks. LTpowerPlay can be used to evaluate Analog Devices ICs by connecting to a demo board or the user application. LTpowerPlay can also be used in an offline mode (with no hardware present) in order to build multiple IC configuration files that can be saved and re-loaded at a later time. LTpowerPlay provides unprecedented diagnostic and debug features. It becomes a valuable diagnostic tool during board bring-up to program or tweak the power system or to diagnose power issues when bringing up rails. LTpowerPlay utilizes Analog Devices's USB-to-I²C/SMBus/PMBus adapter to communication with one of the many potential targets including the DC2155A demo board, or a customer target system. The software also provides an automatic update feature to keep the revision current with the latest set of device drivers and documentation. A great deal of context sensitive help is available with LTpowerPlay along with several tutorial demos. Complete information is available at [LTpowerPlay](#).

APPLICATIONS INFORMATION

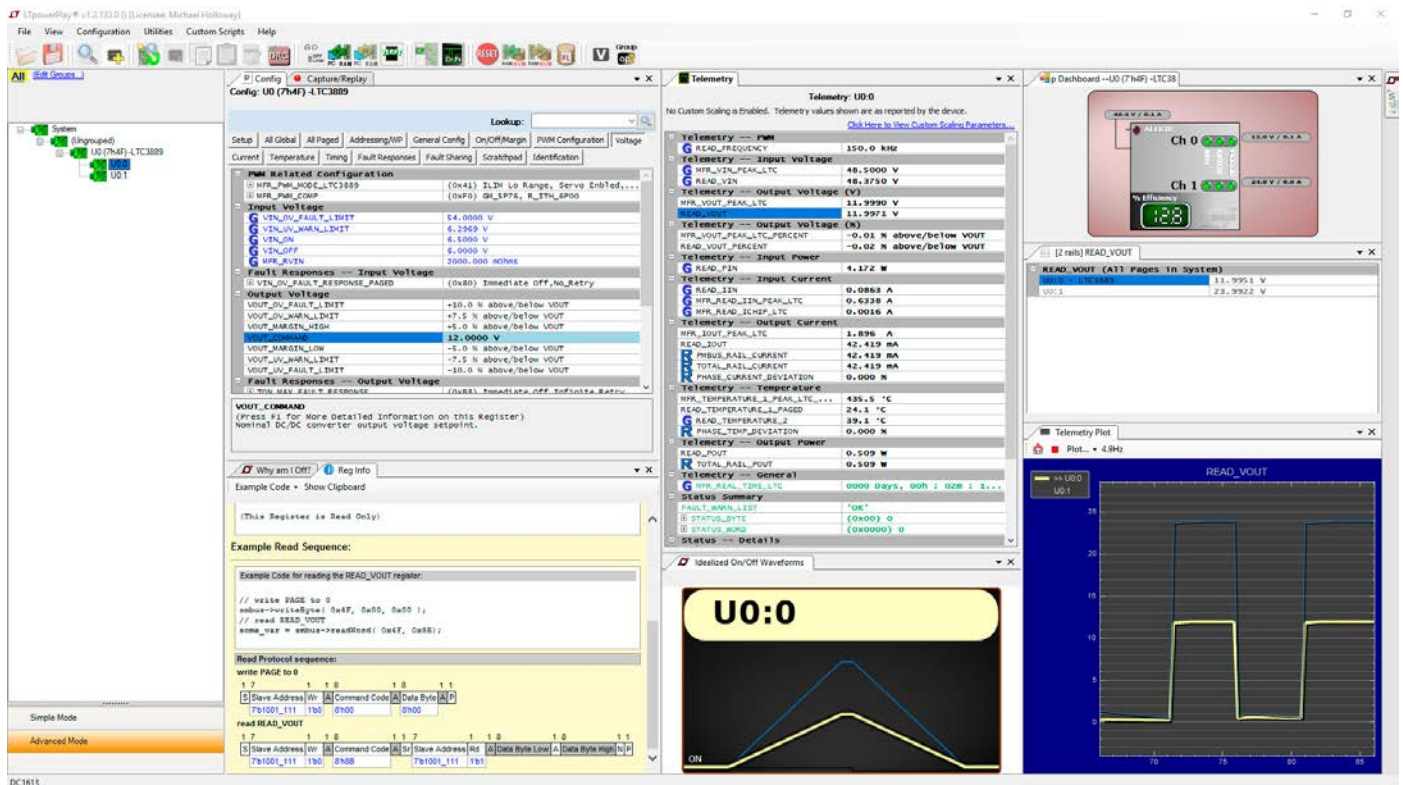

Figure 42. LTpowerPlay Screen Shot

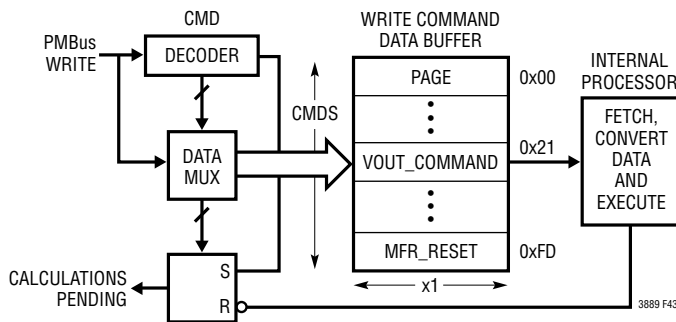

Figure 43. Write Command Data Processing

PMBus COMMUNICATION AND COMMAND PROCESSING

The LTC3889 has a one deep buffer to hold the last data written for each supported command prior to processing as shown in Figure 43; Write Command Data Processing. When the part receives a new command from the bus,

it copies the data into the Write Command Data Buffer, indicates to the internal processor that this command data needs to be fetched, and converts the command to its internal format so that it can be executed.

Two distinct parallel blocks manage command buffering and command processing (fetch, convert, and execute) to ensure the last data written to any command is never lost. Command data buffering handles incoming PMBus writes by storing the command data to the Write Command Data Buffer and marking these commands for future processing. The internal processor runs in parallel and handles the sometimes slower task of fetching, converting and executing commands marked for processing.

Some computationally intensive commands (e.g., timing parameters, temperatures, voltages and currents) have internal processor execution times that may be long relative

APPLICATIONS INFORMATION

```
// wait until chip is not busy
do
{
    mfrCommonValue = PMBUS_READ_BYTE(0xEF);
    partReady = (mfrCommonValue & 0x68) == 0x68;
}while(!partReady)

// now the part is ready to receive the next command
PMBUS_WRITE_WORD(0x21, 0x2000); //write VOUT_COMMAND to 2V
```

Figure 44. Example of a Command Write of VOUT_COMMAND

to PMBus timing. If the part is busy processing a command, and new command(s) arrive, execution may be delayed or processed in a different order than received. The part indicates when internal calculations are in process via bit 5 of MFR_COMMON ('calculations not pending'). When the part is busy calculating, bit 5 is cleared. When this bit is set, the part is ready for another command. An example polling loop is provided in Figure 44 which ensures that commands are processed in order while simplifying error handling routines.

When the part receives a new command while it is busy, it will communicate this condition using standard PMBus protocol. Depending on part configuration it may either NACK the command or return all ones (0xFF) for reads. It may also generate a BUSY fault and $\overline{\text{ALERT}}$ notification, or stretch the SCL clock low. Clock stretching can be enabled by asserting bit 1 of MFR_CONFIG_ALL_LTC3889. Clock stretching will only occur if enabled and the bus communication speed exceeds 100kHz.

PMBus busy protocols are well accepted standards, but can make writing system level software somewhat complex. The part provides three 'hand shaking' status bits which reduce complexity while enabling robust system level communication.

The three hand shaking status bits are in the MFR_COMMON register. When the part is busy executing an internal operation, it will clear bit 6 of MFR_COMMON

('chip not busy'). When the part is busy specifically because it is in a transitional VOUT state (margining hi/lo, power off/on, moving to a new output voltage set point, etc.) it will clear bit 4 of MFR_COMMON ('output not in transition'). When internal calculations are in process, the part will clear bit 5 of MFR_COMMON ('calculations not pending'). These three status bits can be polled with a PMBus read byte of the MFR_COMMON register until all three bits are set. A command immediately following the status bits being set will be accepted without NACKing or generating a BUSY fault/ $\overline{\text{ALERT}}$ notification. The part can NACK commands for other reasons, however, as required by the PMBus spec (for instance, an invalid command or data). An example of a robust command write algorithm for the VOUT_COMMAND register is provided in Figure 44.

It is recommended that all command writes (write byte, write word, etc.) be preceded with a polling loop to avoid the extra complexity of dealing with busy behavior and unwanted $\overline{\text{ALERT}}$ notification. A simple way to achieve this is to create a SAFE_WRITE_BYTE() and SAFE_WRITE_WORD() subroutine. The above polling mechanism allows your software to remain clean and simple while robustly communicating with the part. For a detailed discussion of these topics and other special cases please refer to the application note section located at:

www.linear.com/designtools/app_notes

When communicating using bus speeds at or below 100kHz, the polling mechanism shown here provides a simple solution that ensures robust communication without clock stretching. At bus speeds in excess of 100kHz, it is strongly recommended that the part be configured to enable clock stretching. This requires a PMBus master that supports clock stretching. System software that detects and properly recovers from the standard PMBus NACK/BUSY faults is required.

The LTC3889 is not recommended in applications with bus speeds in excess of 400kHz.

PMBus COMMAND DETAILS

ADDRESSING AND WRITE PROTECT

| COMMAND NAME | CMD CODE | DESCRIPTION | TYPE | PAGED | DATA FORMAT | UNITS | EEPROM | DEFAULT VALUE |
|------------------|----------|--|-----------|-------|-------------|-------|--------|---------------|
| PAGE | 0x00 | Provides integration with multi-page PMBus devices. | R/W Byte | N | Reg | | | 0x00 |
| PAGE_PLUS_WRITE | 0x05 | Write a supported command directly to a PWM channel. | W Block | N | | | | |
| PAGE_PLUS_READ | 0x06 | Read a supported command directly from a PWM channel. | Block R/W | N | | | | |
| WRITE_PROTECT | 0x10 | Level of protection provided by the device against accidental changes. | R/W Byte | N | Reg | | Y | 0x00 |
| MFR_ADDRESS | 0xE6 | Sets the 7-bit I ² C address byte. | R/W Byte | N | Reg | | Y | 0x4F |
| MFR_RAIL_ADDRESS | 0xFA | Common address for PolyPhase outputs to adjust common parameters. | R/W Byte | Y | Reg | | Y | 0x80 |

PAGE

The PAGE command provides the ability to configure, control and monitor both PWM channels through only one physical address, either the MFR_ADDRESS or GLOBAL device address. Each PAGE contains the operating commands for one PWM channel.

Pages 0x00 and 0x01 correspond to Channel 0 and Channel 1, respectively, in this device.

Setting PAGE to 0xFF applies any following paged commands to both outputs. Reading from the device with PAGE set to 0xFF is not recommended.

This command has one data byte.

PAGE_PLUS_WRITE

The PAGE_PLUS_WRITE command provides a way to set the page within a device, send a command, and then send the data for the command, all in one communication packet. Commands allowed by the present write protection level may be sent with PAGE_PLUS_WRITE.

The value stored in the PAGE command is not affected by PAGE_PLUS_WRITE. If PAGE_PLUS_WRITE is used to send a non-paged command, the Page Number byte is ignored.

This command uses Write Block protocol. An example of the PAGE_PLUS_WRITE command with PEC sending a command that has two data bytes is shown in Figure 45.

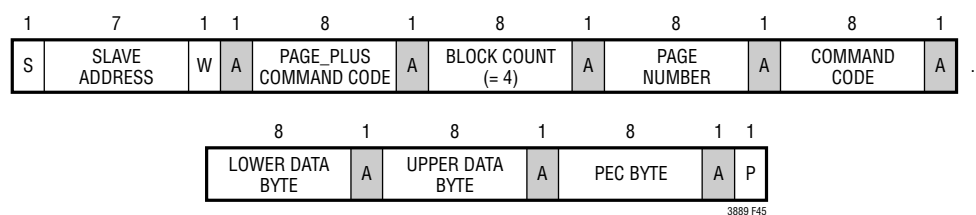

Figure 45. Example of PAGE_PLUS_WRITE

PMBus COMMAND DETAILS

PAGE_PLUS_READ

The PAGE_PLUS_READ command provides the ability to set the page within a device, send a command, and then read the data returned by the command, all in one communication packet.

The value stored in the PAGE command is not affected by PAGE_PLUS_READ. If PAGE_PLUS_READ is used to access data from a non-paged command, the Page Number byte is ignored.

This command uses Block Write-Block Read Process Call protocol. An example of the PAGE_PLUS_READ command with PEC is shown in Figure 46.

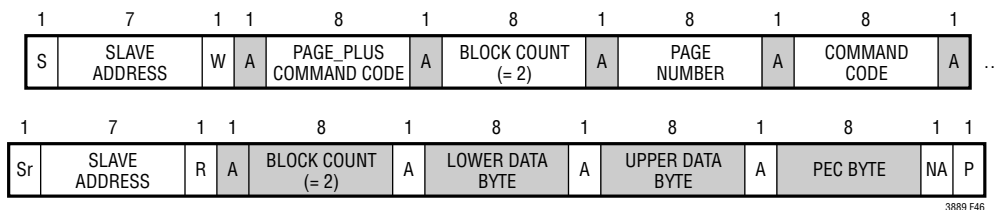

Figure 46. Example of PAGE_PLUS_READ

Note: PAGE_PLUS commands cannot be nested. A PAGE_PLUS command cannot be used to read or write another PAGE_PLUS command. If this is attempted, the LTC3889 will NACK the entire PAGE_PLUS packet and issue a CML fault for Invalid/Unsupported Data.

WRITE_PROTECT

The WRITE_PROTECT command is used to control writing to the LTC3889 device. This command does not indicate the status of the WP pin which is defined in the MFR_COMMON command. The WP pin takes precedence over the value of this command.

| BYTE | MEANING |
|------|--|
| 0x80 | Disable all writes except to the WRITE_PROTECT, PAGE, MFR_EE_UNLOCK, and STORE_USER_ALL command. |
| 0x40 | Disable all writes except to the WRITE_PROTECT, PAGE, MFR_EE_UNLOCK, MFR_CLEAR_PEAKEs, STORE_USER_ALL, OPERATION and CLEAR_FAULTS command. Individual fault bits can be cleared by writing a 1 to the respective bits in the STATUS commands. |
| 0x20 | Disable all writes except to the WRITE_PROTECT, OPERATION, MFR_EE_UNLOCK, MFR_CLEAR_PEAKEs, CLEAR_FAULTS, PAGE, ON_OFF_CONFIG, VOUT_COMMAND and STORE_USER_ALL. Individual fault bits can be cleared by writing a 1 to the respective bits in the STATUS commands. |
| 0x10 | Reserved, must be 0 |
| 0x08 | Reserved, must be 0 |
| 0x04 | Reserved, must be 0 |
| 0x02 | Reserved, must be 0 |
| 0x01 | Reserved, must be 0 |

PMBus COMMAND DETAILS

When WRITE_PROTECT is set to 0x00, writes to all commands are enabled.

If WP pin is high, PAGE, OPERATION, MFR_CLEAR_PEAKS, MFR_EE_UNLOCK, WRITE_PROTECT and CLEAR_FAULTS commands are supported. Individual fault bits can be cleared by writing a 1 to the respective bits in the STATUS commands.

MFR_ADDRESS

The MFR_ADDRESS command byte sets the 7 bits of the PMBus slave address for this device.

Setting this command to a value of 0x80 disables device addressing. The GLOBAL device address, 0x5A and 0x5B, cannot be deactivated. If RCONFIG is set to ignore, the ASEL0 and ASEL1 pins are still used to determine the LSB and MSB, respectively, of the channel address. If the ASEL0 and ASEL1 pins are both open, the LTC3889 will use the address value stored in EEPROM. If the ASEL0 pin is open, the LTC3889 will use the lower 4 bits of the MFR_ADDRESS value stored in EEPROM to construct the effective address of the part. If the ASEL1 pin is open, the LTC3889 will use the upper 3 bits of the MFR_ADDRESS value stored in EEPROM to construct the effective address of the part.

This command has one data byte.

MFR_RAIL_ADDRESS

The MFR_RAIL_ADDRESS command enables direct device address access to the PAGE activated channel. The value of this command should be common to all devices attached to a single power supply rail.

The user should only perform command writes to this address. If a read is performed from this address and the rail devices do not respond with EXACTLY the same value, the LTC3889 will detect bus contention and may set a CML communications fault.

Setting this command to a value of 0x80 disables rail device addressing for the channel.

This command has one data byte.

GENERAL CONFIGURATION COMMANDS

| COMMAND NAME | CMD CODE | DESCRIPTION | TYPE | PAGED | DATA FORMAT | UNITS | EEPROM | DEFAULT VALUE |
|-------------------------|----------|---|----------|-------|-------------|-------|--------|---------------|
| MFR_CHAN_CONFIG_LTC3889 | 0xD0 | Configuration bits that are channel specific. | R/W Byte | Y | Reg | | Y | 0x1D |
| MFR_CONFIG_ALL_LTC3889 | 0xD1 | General configuration bits. | R/W Byte | N | Reg | | Y | 0x21 |

PMBus COMMAND DETAILS

MFR_CHAN_CONFIG_LTC3889

General purpose configuration command common to multiple ADI products.

| BIT | MEANING |
|-----|--|
| 7 | Reserved |
| 6 | Reserved |
| 5 | Reserved |
| 4 | Disable RUN Low. When asserted the RUN pin is not pulsed low if commanded OFF. |
| 3 | Short Cycle. When asserted the output will immediate off if commanded ON while waiting for TOFF_DELAY or TOFF_FALL. TOFF_MIN of 120ms is honored then the part will command ON. |
| 2 | SHARE_CLOCK control. If SHARE_CLOCK is held low, the output is disabled. |
| 1 | ALERT is not pulled low if FAULT is pulled low externally. |
| 0 | Disables the V _{OUT} decay value requirement for MFR_RETRY_TIME processing. When this bit is set to a 0, the output must decay to less than 12.5% of the programmed value before the PWM will restart. This applies to any action that turns off the PWM including a fault, an OFF/ON command, or a RUN pin transition from high to low. A TOFF_MAX warning status will not be generated when this bit is set to a 1. |

This command has one data byte.

MFR_CONFIG_ALL_LTC3889

General purpose configuration command common to multiple ADI products.

| BIT | MEANING |
|-----|--|
| 7 | Enable Fault Logging |
| 6 | Ignore Resistor Configuration Pins |
| 5 | Disable CML Fault for Quick Command Message. |
| 4 | Disable SYNC output |
| 3 | Enable 255ms PMBus timeout |
| 2 | PMBus command writes require a valid Packet Error Checking, PEC, byte to be accepted.* |
| 1 | Enable the use of PMBus clock stretching |
| 0 | Execute CLEAR_FAULTS on rising edge of either RUN pin. |

*PMBus command writes that have a valid PEC byte are always processed. PMBus command writes that have an invalid PEC byte are not processed and set a CML status fault.

This command has one data byte.

ON/OFF/MARGIN

| COMMAND NAME | CMD CODE | DESCRIPTION | TYPE | PAGED | DATA FORMAT | UNITS | EEPROM | DEFAULT VALUE |
|---------------|----------|---|-----------|-------|-------------|-------|--------|---------------|
| ON_OFF_CONFIG | 0x02 | RUN pin and PMBus bus on/off command configuration. | R/W Byte | Y | Reg | | Y | 0x1E |
| OPERATION | 0x01 | Operating mode control. On/off, margin high and margin low. | R/W Byte | Y | Reg | | Y | 0x40 |
| MFR_RESET | 0xFD | Commanded reset without requiring a power-down. | Send Byte | N | | | | NA |

PMBus COMMAND DETAILS

ON_OFF_CONFIG

The ON_OFF_CONFIG command specifies the combination of RUN n pin input state and PMBus commands needed to turn the PWM channel on and off.

Supported Values:

| VALUE | MEANING |
|-------|---|
| 0x1F | OPERATION value and RUN n pin must both command the device to start/run. Device executes immediate off when commanded off. |
| 0x1E | OPERATION value and RUN n pin must both command the device to start/run. Device uses TOFF_ command values when commanded off. |
| 0x17 | RUN n pin control with immediate off when commanded off. OPERATION on/off control ignored. |
| 0x16 | RUN n pin control using TOFF_ command values when commanded off. OPERATION on/off control ignored. |

Programming an unsupported ON_OFF_CONFIG value will generate a CML fault and the command will be ignored.

This command has one data byte.

OPERATION

The OPERATION command is used to turn the unit on and off in conjunction with the input from the RUN n pins. It is also used to cause the unit to set the output voltage to the upper or lower MARGIN VOLTAGEs. The unit stays in the commanded operating mode until a subsequent OPERATION command or change in the state of the RUN n pin instructs the device to change to another mode. If the part is stored in the MARGIN_LOW/HIGH state, the next RESET or POWER_ON cycle will ramp to that state. If the OPERATION command is modified, for example ON is changed to MARGIN_LOW, the output will move at a fixed slope set by the VOUT_TRANSITION_RATE. The default operation command is sequence off. If V_{IN} is applied to a part with factory default programming and the VOUT_CONFIG resistor configuration pins are not installed, the outputs will be commanded off.

The part defaults to the Sequence Off state.

This command has one data byte.

Supported Values:

| VALUE | MEANING |
|-------|--|
| 0xA8 | Margin high. |
| 0x98 | Margin low. |
| 0x80 | On (V _{OUT} back to nominal even if bit 3 of ON_OFF_CONFIG is not set). |
| 0x40* | Soft off (with sequencing). |
| 0x00* | Immediate off (no sequencing). |

*Device does not respond to these commands if bit 3 of ON_OFF_CONFIG is not set.

Programming an unsupported OPERATION value will generate a CML fault and the command will be ignored.

This command has one data byte.

PMBus COMMAND DETAILS

MFR_RESET

This command provides a means to reset the LTC3889 from the serial bus. This forces the LTC3889 to turn off both PWM channels, load the operating memory from internal EEPROM, clear all faults and then perform a soft-start of both PWM channels, if enabled.

This write-only command has no data bytes.

PWM CONFIGURATION

| COMMAND NAME | CMD CODE | DESCRIPTION | TYPE | PAGED | DATA FORMAT | UNITS | EEPROM | DEFAULT VALUE |
|------------------------|----------|---|----------|-------|-------------|-------|--------|---------------|
| MFR_PWM_COMP | 0xD3 | PWM loop compensation configuration | R/W Byte | Y | Reg | | Y | 0x70 |
| MFR_PWM_MODE_LTC3889 | 0xD4 | Configuration for the PWM engine. | R/W Byte | Y | Reg | | Y | 0xC1 |
| MFR_PWM_CONFIG_LTC3889 | 0xF5 | Set numerous parameters for the DC/DC controller including phasing. | R/W Byte | N | Reg | | Y | 0x10 |
| FREQUENCY_SWITCH | 0x33 | Switching frequency of the controller. | R/W Word | N | L11 | kHz | Y | 250 0xF3E8 |

MFR_PWM_MODE_LTC3889

The MFR_PWM_MODE_LTC3889 command sets important PWM controls for each channel. Bits [0] and [6] may be changed when the addressed channel(s) is on, however the channel(s) must be turned off if any other bits are changed when the command is issued. The LTC3889 will issue a CML fault and ignore the command and its data if the channel is on and any bits other than [0] and [6] are changed.

The MFR_PWM_MODE_LTC3889 command allows the user to program the PWM controller to use discontinuous (pulse-skipping mode), or forced continuous conduction mode.

| BIT | MEANING |
|--------|--|
| 7 | Use High Range of I_{LIMIT} |
| 0b | Low Current Range |
| 1b | High Current Range |
| 6 | Enable Servo Mode |
| 5 | External temperature sense: 0: ΔV_{BE} measurement. 1: Direct voltage measurement. |
| [4] | Reserved |
| [3:2]* | DRVSET: DRV _{CC} voltage select and EXT _{VCC} switch over threshold |
| 00b | DRV _{CC} = 6.3V, EXT _{VCC} threshold = 5.3V |
| 01b | DRV _{CC} = 7.4V, EXT _{VCC} threshold = 7.7V |
| 10b | DRV _{CC} = 9.0V, EXT _{VCC} threshold = 7.7V |
| 1 | V _{OUT} Range |
| 0b | The maximum output voltage is 40V |
| 1b | The maximum output voltage is 8V |
| Bit[0] | Mode |
| 0b | Discontinuous |
| 1b | Forced Continuous |

*Page 0 only. Page 1 bits[3:2] are reserved.

PMBus COMMAND DETAILS

Bit [7] of this command determines if the part is in high range or low range of the IOUT_OC_FAULT_LIMIT command. Changing this bit value changes the PWM loop gain and compensation.

Bit [6] The LTC3889 will not servo while the part is OFF, ramping on or ramping off. When set to a one, the output servo is enabled. The output set point DAC will be slowly adjusted to minimize the difference between the READ_VOUT_ADC and the VOUT_COMMAND (or the appropriate margined value).

When Bit[5] is cleared, the LTC3889 computes temperature in °C from ΔV_{BE} measured by the ADC at the TSNS $_n$ pin as

$$T = (G \cdot \Delta V_{BE} \cdot q / (K \cdot \ln(16))) - 273.15 + O$$

When Bit[5] is set, the LTC3889 computes temperature in °C from TSNS $_n$ voltage measured by the ADC as

$$T = (G \cdot (1.35 - V_{TSNS_n} + O) / 4.3e-3) + 25$$

For both equations,

$$G = \text{MFR_TEMP_1_GAIN} \cdot 2^{-14}, \text{ and}$$

$$O = \text{MFR_TEMP_1_OFFSET}$$

Bits[3:2] of this command on Page 0 determine the DRV $_{CC}$ voltage and the EXTV $_{CC}$ switch over threshold. Changing the value of these bits when the channel output is active will generate a CML fault. These bits are reserved on Page 1.

Bit[1] of this command determines if the part is in high range or low voltage range. Changing this bit value changes the PWM loop gain and compensation. This bit value cannot be changed when the channel output is active. Changing this bit when the channel is active will generate a CML fault.

Bit[0] determines if the PWM mode of operation is discontinuous (pulse-skipping mode), or forced continuous conduction mode. This command has one data byte. Whenever the channel is ramping on, the PWM mode will be discontinuous, regardless of the value of this command.

MFR_PWM_COMP

The MFR_PWM_COMP command sets the gm of the PWM channel error amplifiers and the value of the internal R $_{THn}$ compensation resistors. This command affects the loop gain of the PWM output which may require modifications to the external compensation network.

| BIT | MEANING |
|-----------|-----------------|
| BIT [7:5] | EA $_{gm}$ (mS) |
| 000b | 1.00 |
| 001b | 1.68 |
| 010b | 2.35 |
| 011b | 3.02 |
| 100b | 3.69 |
| 101b | 4.36 |
| 110b | 5.04 |
| 111b | 5.73 |

PMBus COMMAND DETAILS

| BIT | MEANING |
|------------------|-----------------------------|
| BIT [4:0] | R_{ITH} (kΩ) |
| 00000b | 0 |
| 00001b | 0.25 |
| 00010b | 0.5 |
| 00011b | 0.75 |
| 00100b | 1 |
| 00101b | 1.25 |
| 00110b | 1.5 |
| 00111b | 1.75 |
| 01000b | 2 |
| 01001b | 2.5 |
| 01010b | 3 |
| 01011b | 3.5 |
| 01100b | 4 |
| 01101b | 4.5 |
| 01110b | 5 |
| 01111b | 5.5 |
| 10000b | 6 |
| 10001b | 7 |
| 10010b | 8 |
| 10011b | 9 |
| 10100b | 11 |
| 10101b | 13 |
| 10110b | 15 |
| 10111b | 17 |
| 11000b | 20 |
| 11001b | 24 |
| 11010b | 28 |
| 11011b | 32 |
| 11100b | 38 |
| 11101b | 46 |
| 11110b | 54 |
| 11111b | 62 |

This command has one data byte.

PMBus COMMAND DETAILS

MFR_PWM_CONFIG_LTC3889

The MFR_PWM_CONFIG_LTC3889 command sets the switching frequency phase offset with respect to the falling edge of the SYNC signal. The part must be in the OFF state to process this command. Either the RUN pins must be low or the part must be commanded off. If either channel is in the RUN state and this command is written, the command will be NACK'd and a BUSY fault will be asserted.

| BIT | MEANING | |
|-----------|--|---------------------|
| 7 | Use VFBO | |
| 0b | Feedback nodes of both channels are independent. | |
| 1b | Channel 1 uses the Channel 0 feedback node. | |
| [6:5] | Input current sense gain. | |
| 00b | 2x gain. 0mV to 50mV range. | |
| 01b | 4x gain. 0mV to 20mV range. | |
| 10b | 8x gain. 0mV to 5mV range. | |
| 11b | Not supported. Do not use. | |
| 4 | Share Clock Enable : If this bit is 1, the SHARE_CLK pin will not be released until $V_{IN} > V_{IN_ON}$. The SHARE_CLK pin will be pulled low when $V_{IN} < V_{IN_OFF}$. If this bit is 0, the SHARE_CLK pin will not be pulled low when $V_{IN} < V_{IN_OFF}$ except for the initial application of V_{IN} . | |
| BIT [2:0] | CHANNEL 0 (DEGREES) | CHANNEL 1 (DEGREES) |
| 000b | 0 | 180 |
| 001b | 90 | 270 |
| 010b | 0 | 240 |
| 011b | 0 | 120 |
| 100b | 120 | 240 |
| 101b | 60 | 240 |
| 110b | 120 | 300 |

Do not assert Bit[7] except for use in a PolyPhase configuration. The V_{SENSEn}^{+} , I_{THn} , $PGOODn$ and $RUNn$ must be shared between channels when this bit is asserted.

FREQUENCY_SWITCH

The FREQUENCY_SWITCH command sets the switching frequency, in kHz, of the LTC3889. This command can be set to any value between 85 and 500.

The part must be in the OFF state to process this command. The RUN pin must be low or both channels must be commanded off. If the part is in the RUN state and this command is written, the command will be NACK'd and a BUSY fault will be asserted. When the part is commanded off and the frequency is changed, a PLL_UNLOCK status may be detected as the PLL locks onto the new frequency.

This command has two data bytes and is formatted in Linear_5s_11s format.

PMBus COMMAND DETAILS

VOLTAGE

Input Voltage and Limits

| COMMAND NAME | CMD CODE | DESCRIPTION | TYPE | PAGED | DATA FORMAT | UNITS | EEPROM | DEFAULT VALUE |
|--------------------|----------|---|----------|-------|-------------|-------|--------|----------------|
| VIN_OV_FAULT_LIMIT | 0x55 | Input supply overvoltage fault limit. | R/W Word | N | L11 | V | Y | 48.0 0xE300 |
| VIN_UV_WARN_LIMIT | 0x58 | Input supply undervoltage warning limit. | R/W Word | N | L11 | V | Y | 6.3 0xCB26 |
| VIN_ON | 0x35 | Input voltage at which the unit should start power conversion. | R/W Word | N | L11 | V | Y | 6.5 0xCB40 |
| VIN_OFF | 0x36 | Input voltage at which the unit should stop power conversion. | R/W Word | N | L11 | V | Y | 6.0 0xCB00 |
| MFR_RVIN | 0xF7 | The resistance value of the V _{IN} pin filter element in milliohms | R/W Word | N | L11 | mΩ | Y | 2000 0x0BE8 |

VIN_OV_FAULT_LIMIT

The VIN_OV_FAULT_LIMIT command sets the value of the input voltage measured by the ADC, in volts, that causes an input overvoltage fault.

This command has two data bytes in Linear_5s_11s format.

VIN_UV_WARN_LIMIT

The VIN_UV_WARN_LIMIT command sets the value of input voltage measured by the ADC that causes an input undervoltage warning. This warning is disabled until the input exceeds the input startup threshold value set by the VIN_ON command and the unit has been enabled. If the VIN_UV_WARN_LIMIT is then exceeded, the device:

- Sets the INPUT Bit Is the STATUS_WORD
- Sets the V_{IN} Undervoltage Warning Bit in the STATUS_INPUT Command
- Notifies the Host by Asserting $\overline{\text{ALERT}}$, Unless Masked

VIN_ON

The VIN_ON command sets the input voltage, in volts, at which the unit should start power conversion.

This command has two data bytes and is formatted in Linear_5s_11s format.

VIN_OFF

The VIN_OFF command sets the input voltage, in volts, at which the unit should stop power conversion.

This command has two data bytes and is formatted in Linear_5s_11s format.

PMBus COMMAND DETAILS

MFR_RVIN

The MFR_RVIN command is used to set the resistance value of the V_{IN} pin filter element in milliohms. (See also READ_VIN). Set MFR_RVIN equal to 0 if no filter element is used.

This command has two data bytes and is formatted in Linear_5s_11s format.

Output Voltage and Limits

| COMMAND NAME | CMD CODE | DESCRIPTION | TYPE | PAGED | DATA FORMAT | UNITS | EEPROM | DEFAULT VALUE |
|---------------------|----------|--|----------|-------|-------------|-------|--------|-------------------|
| VOUT_MODE | 0x20 | Output voltage format and exponent | R Byte | Y | Reg | | | 2^{-10} 0x16 |
| VOUT_MAX | 0x24 | Upper limit on the output voltage the unit can command regardless of any other commands. | R/W Word | Y | L16 | V | Y | 40 0xA000 |
| VOUT_OV_FAULT_LIMIT | 0x40 | Output overvoltage fault limit. | R/W Word | Y | L16 | V | Y | 5.5 0x1600 |
| VOUT_OV_WARN_LIMIT | 0x42 | Output overvoltage warning limit. | R/W Word | Y | L16 | V | Y | 5.375 0x1580 |
| VOUT_MARGIN_HIGH | 0x25 | Margin high output voltage set point. Must be greater than VOUT_COMMAND. | R/W Word | Y | L16 | V | Y | 5.25 0x1500 |
| VOUT_COMMAND | 0x21 | Nominal output voltage set point. | R/W Word | Y | L16 | V | Y | 5.0 0x1400 |
| VOUT_MARGIN_LOW | 0x26 | Margin low output voltage set point. Must be less than VOUT_COMMAND. | R/W Word | Y | L16 | V | Y | 4.75 0x1300 |
| VOUT_UV_WARN_LIMIT | 0x43 | Output undervoltage warning limit. | R/W Word | Y | L16 | V | Y | 4.625 1280 |
| VOUT_UV_FAULT_LIMIT | 0x44 | Output undervoltage fault limit. | R/W Word | Y | L16 | V | Y | 4.5 0x1200 |
| MFR_VOUT_MAX | 0xA5 | Maximum allowed output voltage. | R Word | Y | L16 | V | | 40.5 0xA200 |

VOUT_MODE

The data byte for VOUT_MODE command, used for commanding and reading output voltage, consists of a 3-bit mode (only linear format is supported) and a 5-bit parameter representing the exponent used in output voltage Read/Write commands.

This read-only command has one data byte.

VOUT_MAX

The VOUT_MAX command sets an upper limit on any voltage, including VOUT_MARGIN_HIGH, the unit can command regardless of any other commands or combinations. The maximum allowed value of this command is 40.5 volts. The maximum output voltage the LTC3889 can produce is 40.5 volts including VOUT_MARGIN_HIGH. However, the VOUT_OV_FAULT_LIMIT can only be commanded as high as 40.5 volts.

This command has two data bytes and is formatted in Linear_16u format.

PMBus COMMAND DETAILS

VOUT_OV_FAULT_LIMIT

The VOUT_OV_FAULT_LIMIT command sets the value of the output voltage measured by the OV supervisor comparator at the sense pins, in volts, which causes an output overvoltage fault.

If the VOUT_OV_FAULT_LIMIT is modified and the part is in the RUN state, allow 10ms after the command is modified to assure the new value is being honored. The part indicates if it is busy making a calculation. Monitor bits 5 and 6 of MFR_COMMON. Either bit is low if the part is busy. If this wait time is not met, and the VOUT_COMMAND is modified above the old overvoltage limit, an OV condition might temporarily be detected resulting in undesirable behavior and possible damage to the switcher.

If VOUT_OV_FAULT_RESPONSE is set to OV_PULLDOWN or 0x00, the $\overline{\text{FAULT}}$ pin will not assert if VOUT_OV_FAULT is propagated. The LTC3889 will pull the TG low and assert the BG bit as soon as the overvoltage condition is detected.

This command has two data bytes and is formatted in Linear_16u format.

VOUT_OV_WARN_LIMIT

The VOUT_OV_WARN_LIMIT command sets the value of the output voltage measured by the ADC at the sense pins, in volts, which causes an output voltage high warning. The MFR_VOUT_PEAK value will be used to determine if this limit has been exceeded.

In response to the VOUT_OV_WARN_LIMIT being exceeded, the device:

- Sets the NONE_OF_THE_ABOVE bit in the STATUS_BYTE
- Sets the VOUT bit in the STATUS_WORD
- Sets the VOUT Overvoltage Warning bit in the STATUS_VOUT command
- Notifies the host by asserting $\overline{\text{ALERT}}$ pin, unless masked

This condition is detected by the ADC so the response time may be up to 120ms.

This command has two data bytes and is formatted in Linear_16u format.

VOUT_MARGIN_HIGH

The VOUT_MARGIN_HIGH command loads the unit with the voltage to which the output is to be changed, in volts, when the OPERATION command is set to "Margin High". The value must be greater than VOUT_COMMAND. The maximum guaranteed value on VOUT_MARGIN_HIGH is 40.5V.

This command will not be acted on during TON_RISE and TOFF_FALL output sequencing. The VOUT_TRANSITION_RATE will be used if this command is modified while the output is active and in a steady-state condition.

This command has two data bytes and is formatted in Linear_16u format.

PMBus COMMAND DETAILS

VOUT_COMMAND

The VOUT_COMMAND consists of two bytes and is used to set the output voltage, in volts. The maximum guaranteed value on VOUT is 40.5 volts.

This command will not be acted on during TON_RISE and TOFF_FALL output sequencing. The VOUT_TRANSITION_RATE will be used if this command is modified while the output is active and in a steady-state condition.

This command has two data bytes and is formatted in Linear_16u format.

VOUT_MARGIN_LOW

The VOUT_MARGIN_LOW command loads the unit with the voltage to which the output is to be changed, in volts, when the OPERATION command is set to “Margin Low”. The value must be less than VOUT_COMMAND.

This command will not be acted on during TON_RISE and TOFF_FALL output sequencing. The VOUT_TRANSITION_RATE will be used if this command is modified while the output is active and in a steady-state condition.

This command has two data bytes and is formatted in Linear_16u format.

VOUT_UV_WARN_LIMIT

The VOUT_UV_WARN_LIMIT command reads the value of the output voltage measured by the ADC at the sense pins, in volts, which causes an output voltage low warning.

In response to the VOUT_UV_WARN_LIMIT being exceeded, the device:

- Sets the NONE_OF_THE_ABOVE bit in the STATUS_BYTE
- Sets the VOUT bit in the STATUS_WORD
- Sets the VOUT Undervoltage Warning bit in the STATUS_VOUT command
- Notifies the host by asserting $\overline{\text{ALERT}}$ pin, unless masked

This command has two data bytes and is formatted in Linear_16u format.

VOUT_UV_FAULT_LIMIT

The VOUT_UV_FAULT_LIMIT command reads the value of the output voltage measured by the UV supervisor comparator at the sense pins, in volts, which causes an output undervoltage fault.

This command has two data bytes and is formatted in Linear_16u format.

PMBus COMMAND DETAILS

MFR_VOUT_MAX

The MFR_VOUT_MAX command is the maximum output voltage in volts for each channel, including VOUT_OV_FAULT_LIMIT. If the output voltages are set to high range (Bit 1 of MFR_PWM_MODE_LTC3889 set to a 0) MFR_VOUT_MAX is 40.5V. If the output voltage is set to low range (Bit 1 of MFR_PWM_MODE_LTC3889 set to a 1) the MFR_VOUT_MAX is 8V. Entering a VOUT_COMMAND value greater than this will result in a CML fault and the output voltage setting will be clamped to the maximum level. This will also result in Bit 3 VOUT_MAX_Warning in the STATUS_VOUT command being set.

This read only command has 2 data bytes and is formatted in Linear_16u format.

OUTPUT CURRENT AND LIMITS

| COMMAND NAME | CMD CODE | DESCRIPTION | TYPE | PAGED | DATA FORMAT | UNITS | EEPROM | DEFAULT VALUE |
|----------------------|----------|---|----------|-------|-------------|-------|--------|-----------------|
| IOUT_CAL_GAIN | 0x38 | The ratio of the voltage at the current sense pins to the sensed current. For devices using a fixed current sense resistor, it is the resistance value in mΩ. | R/W Word | Y | L11 | mΩ | Y | 1.8 0xBB9A |
| MFR_IOUT_CAL_GAIN_TC | 0xF6 | Temperature coefficient of the current sensing element. | R/W Word | Y | CF | | Y | 0 0x0000 |
| IOUT_OC_FAULT_LIMIT | 0x46 | Output overcurrent fault limit. | R/W Word | Y | L11 | A | Y | 29.75 0xDBB8 |
| IOUT_OC_WARN_LIMIT | 0x4A | Output overcurrent warning limit. | R/W Word | Y | L11 | A | Y | 20.0 0xDA80 |

IOUT_CAL_GAIN

The IOUT_CAL_GAIN command is used to set the resistance value of the current sense resistor in milliohms. (see also MFR_IOUT_CAL_GAIN_TC).

This command has two data bytes and is formatted in Linear_5s_11s format.

MFR_IOUT_CAL_GAIN_TC

The MFR_IOUT_CAL_GAIN_TC command allows the user to program the temperature coefficient of the IOUT_CAL_GAIN sense resistor or inductor DCR in ppm/°C.

This command has two data bytes and is formatted in 16-bit 2's complement integer ppm. $N = -32768$ to $32767 \cdot 10^{-6}$. Nominal temperature is 27°C. The IOUT_CAL_GAIN is multiplied by:

$$[1.0 + \text{MFR_IOUT_CAL_GAIN_TC} \cdot (\text{READ_TEMPERATURE_1-27})]. \text{ DCR sensing will have a typical value of } 3900.$$

The IOUT_CAL_GAIN and MFR_IOUT_CAL_GAIN_TC impact all current parameters including: READ_IOUT, MFR_READ_IIN_CHAN, IOUT_OC_FAULT_LIMIT and IOUT_OC_WARN_LIMIT.

PMBus COMMAND DETAILS

IOUT_OC_FAULT_LIMIT

The IOUT_OC_FAULT_LIMIT command sets the value of the peak output current limit, in amperes. When the controller is in current limit, the overcurrent detector will indicate an overcurrent fault condition. The programmed overcurrent fault limit value is rounded up to the nearest one of the following set of discrete values:

| | |
|----------------------|--|
| 25mV/IOUT_CAL_GAIN | Low Range (1.5x Nominal Loop Gain) MFR_PWM_MODE_LTC3889 [7]=0 |
| 28.6mV/IOUT_CAL_GAIN | |
| 32.1mV/IOUT_CAL_GAIN | |
| 35.7mV/IOUT_CAL_GAIN | |
| 39.3mV/IOUT_CAL_GAIN | |
| 42.9mV/IOUT_CAL_GAIN | |
| 46.4mV/IOUT_CAL_GAIN | |
| 50mV/IOUT_CAL_GAIN | |
| 37.5mV/IOUT_CAL_GAIN | High Range (Nominal Loop Gain) MFR_PWM_MODE_LTC3889 [7]=1 |
| 42.9mV/IOUT_CAL_GAIN | |
| 48.2mV/IOUT_CAL_GAIN | |
| 53.6mV/IOUT_CAL_GAIN | |
| 58.9mV/IOUT_CAL_GAIN | |
| 64.3mV/IOUT_CAL_GAIN | |
| 69.6mV/IOUT_CAL_GAIN | |
| 75mV/IOUT_CAL_GAIN | |

Note: This is the peak of the current waveform. The READ_IOUT command returns the average current. The peak output current limits are adjusted with temperature based on the MFR_IOUT_CAL_GAIN_TC using the equation:

$$\text{Peak Current Limit} = \text{IOUT_CAL_GAIN} \cdot (1 + \text{MFR_IOUT_CAL_GAIN_TC} \cdot (\text{READ_TEMPERATURE}_1 - 27.0)).$$

The LTpowerPlay GUI automatically convert the voltages to currents.

The IOUT range is set with bit 7 of the MFR_PWM_MODE_LTC3889 command.

The IOUT_OC_FAULT_LIMIT is ignored during TON_RISE and TOFF_FALL.

If the IOUT_OC_FAULT_LIMIT is exceeded, the device:

- Sets the IOUT bit in the STATUS word
- Sets the IOUT Overcurrent fault bit in the STATUS_IOUT
- Notifies the host by asserting $\overline{\text{ALERT}}$, unless masked

This command has two data bytes and is formatted in Linear_5s_11s format.

PMBus COMMAND DETAILS

IOUT_OC_WARN_LIMIT

This command sets the value of the output current measured by the ADC that causes an output overcurrent warning in amperes. The READ_IOUT value will be used to determine if this limit has been exceeded.

In response to the IOUT_OC_WARN_LIMIT being exceeded, the device:

- Sets the NONE_OF_THE_ABOVE bit in the STATUS_BYTE
- Sets the IOUT bit in the STATUS_WORD
- Sets the IOUT Overcurrent Warning bit in the STATUS_IOUT command, and
- Notifies the host by asserting $\overline{\text{ALERT}}$ pin, unless masked

The IOUT_OC_FAULT_LIMIT is ignored during TON_RISE and TOFF_FALL.

This command has two data bytes and is formatted in Linear_5s_11s format

Input Current and Limits

| COMMAND NAME | CMD CODE | DESCRIPTION | TYPE | PAGED | DATA FORMAT | UNITS | EEPROM | DEFAULT VALUE |
|-------------------|----------|---|----------|-------|-------------|------------|--------|-----------------|
| MFR_IIN_CAL_GAIN | 0xE8 | The resistance value of the input current sense element in m Ω . | R/W Word | N | L11 | m Ω | Y | 5.000 0xCA80 |
| IIN_OC_WARN_LIMIT | 0x5D | Input overcurrent warning limit. | R/W Word | N | L11 | A | Y | 10.0 0xD280 |

MFR_IIN_CAL_GAIN

The MFR_IIN_CAL_GAIN command is used to set the resistance value of the input current sense resistor in milliohms. (see also READ_IIN).

This command has two data bytes and is formatted in Linear_5s_11s format.

IIN_OC_WARN_LIMIT

The IIN_OC_WARN_LIMIT command sets the value of the input current measured by the ADC, in amperes, that causes a warning indicating the input current is high. The READ_IIN value will be used to determine if this limit has been exceeded.

In response to the IIN_OC_WARN_LIMIT being exceeded, the device:

- Sets the NONE_OF_THE_ABOVE bit in the STATUS_BYTE
- Sets the INPUT bit in the upper byte of the STATUS_WORD
- Sets the IIN Overcurrent Warning bit[1] in the STATUS_INPUT command, and
- Notifies the host by asserting $\overline{\text{ALERT}}$ pin

This command has two data bytes and is formatted in Linear_5s_11s format.

PMBus COMMAND DETAILS

TEMPERATURE

External Temperature Calibration

| COMMAND NAME | CMD CODE | DESCRIPTION | TYPE | PAGED | DATA FORMAT | UNITS | EEPROM | DEFAULT VALUE |
|-------------------|----------|---|----------|-------|-------------|-------|--------|---------------|
| MFR_TEMP_1_GAIN | 0xF8 | Sets the slope of the external temperature sensor. | R/W Word | Y | CF | | Y | 1.0 0x4000 |
| MFR_TEMP_1_OFFSET | 0xF9 | Sets the offset of the external temperature sensor. | R/W Word | Y | L11 | C | Y | 0.0 0x8000 |

MFR_TEMP_1_GAIN

The MFR_TEMP_1_GAIN command will modify the slope of the external temperature sensor to account for non-idealities in the element and errors associated with the remote sensing of the temperature in the inductor.

This command has two data bytes and is formatted in 16-bit 2's complement integer. The effective gain adjustment is $N \cdot 2^{-14}$. The nominal value is 1.

MFR_TEMP_1_OFFSET

The MFR_TEMP_1_OFFSET command will modify the offset of the external temperature sensor to account for non-idealities in the element and errors associated with the remote sensing of the temperature in the inductor.

This command has two data bytes and is formatted in Linear_5s_11s format.

External Temperature Limits

| COMMAND NAME | CMD CODE | DESCRIPTION | TYPE | PAGED | DATA FORMAT | UNITS | EEPROM | DEFAULT VALUE |
|----------------|----------|---|----------|-------|-------------|-------|--------|-----------------|
| OT_FAULT_LIMIT | 0x4F | External overtemperature fault limit. | R/W Word | Y | L11 | C | Y | 100.0 0xEB20 |
| OT_WARN_LIMIT | 0x51 | External overtemperature warning limit. | R/W Word | Y | L11 | C | Y | 85.0 0xEAA8 |
| UT_FAULT_LIMIT | 0x53 | External undertemperature fault limit. | R/W Word | Y | L11 | C | Y | -40.0 0xE580 |

OT_FAULT_LIMIT

The OT_FAULT_LIMIT command sets the value of the external sense temperature measured by the ADC, in degrees Celsius, which causes an overtemperature fault. The READ_TEMPERATURE_1 value will be used to determine if this limit has been exceeded.

This command has two data bytes and is formatted in Linear_5s_11s format.

PMBus COMMAND DETAILS

OT_WARN_LIMIT

The OT_WARN_LIMIT command sets the value of the external sense temperature measured by the ADC, in degrees Celsius, which causes an overtemperature warning. The READ_TEMPERATURE_1 value will be used to determine if this limit has been exceeded.

In response to the OT_WARN_LIMIT being exceeded, the device:

- Sets the TEMPERATURE bit in the STATUS_BYTE
- Sets the Overtemperature Warning bit in the STATUS_TEMPERATURE command, and
- Notifies the host by asserting $\overline{\text{ALERT}}$ pin, unless masked

This command has two data bytes and is formatted in Linear_5s_11s format.

UT_FAULT_LIMIT

The UT_FAULT_LIMIT command sets the value of the external sense temperature measured by the ADC, in degrees Celsius, which causes an undertemperature fault. The READ_TEMPERATURE_1 value will be used to determine if this limit has been exceeded.

Note: If the temp sensors are not installed, the UT_FAULT_LIMIT can be set to -275°C and UT_FAULT_LIMIT response set to ignore to avoid $\overline{\text{ALERT}}$ being asserted.

This command has two data bytes and is formatted in Linear_5s_11s format.

TIMING

Timing—On Sequence/Ramp

| COMMAND NAME | CMD CODE | DESCRIPTION | TYPE | PAGED | DATA FORMAT | UNITS | EEPROM | DEFAULT VALUE |
|----------------------|----------|---|----------|-------|-------------|-------|--------|----------------|
| TON_DELAY | 0x60 | Time from RUN and/or Operation on to output rail turn-on. | R/W Word | Y | L11 | ms | Y | 0.0 0x8000 |
| TON_RISE | 0x61 | Time from when the output starts to rise until the output voltage reaches the VOUT commanded value. | R/W Word | Y | L11 | ms | Y | 8.0 0xD200 |
| TON_MAX_FAULT_LIMIT | 0x62 | Maximum time from the start of TON_RISE for VOUT to cross the VOUT_UV_FAULT_LIMIT. | R/W Word | Y | L11 | ms | Y | 10.0 0xD280 |
| VOUT_TRANSITION_RATE | 0x27 | Rate the output changes when VOUT commanded to a new value. | R/W Word | Y | L11 | V/ms | Y | 0.25 0xAA00 |

TON_DELAY

The TON_DELAY command sets the time, in milliseconds, from when a start condition is received until the output voltage starts to rise. Values from 0ms to 83 seconds are valid. The resulting turn-on delay will have a typical delay of 270 μs for TON_DELAY = 0 and an uncertainty of $\pm 50\mu\text{s}$ for all values of TON_DELAY.

This command has two data bytes and is formatted in Linear_5s_11s format.

PMBus COMMAND DETAILS

TON_RISE

The TON_RISE command sets the time, in milliseconds, from the time the output starts to rise to the time the output enters the regulation band. Values from 0 to 1.3 seconds are valid. The part will be in discontinuous mode during TON_RISE events. If TON_RISE is less than 0.25ms, the LTC3889 digital slope will be bypassed and the output voltage transition will only be controlled by the analog performance of the PWM switcher. The number of steps in TON_RISE is equal to TON_RISE (in ms)/0.1ms with an uncertainty of ± 0.1 ms.

This command has two data bytes and is formatted in Linear_5s_11s format.

TON_MAX_FAULT_LIMIT

The TON_MAX_FAULT_LIMIT command sets the value, in milliseconds, on how long the unit can attempt to power up the output without reaching the output undervoltage fault limit, or output overcurrent limit.

A data value of 0ms means that there is no limit and that the unit can attempt to bring up the output voltage indefinitely. The maximum limit is 83 seconds.

This command has two data bytes and is formatted in Linear_5s_11s format.

VOUT_TRANSITION_RATE

When a PMBus device receives either a VOUT_COMMAND or OPERATION (Margin High, Margin Low) that causes the output voltage to change this command set the rate in V/ms at which the output voltage changes. This commanded rate of change does not apply when the unit is commanded on or off. The maximum allowed slope is 4V/ms.

This command has two data bytes and is formatted in Linear_5s_11s format.

Timing—Off Sequence/Ramp

| COMMAND NAME | CMD CODE | DESCRIPTION | TYPE | PAGED | DATA FORMAT | UNITS | EEPROM | DEFAULT VALUE |
|---------------------|----------|---|----------|-------|-------------|-------|--------|---------------|
| TOFF_DELAY | 0x64 | Time from RUN and/or Operation off to the start of TOFF_FALL ramp. | R/W Word | Y | L11 | ms | Y | 0.0 0x8000 |
| TOFF_FALL | 0x65 | Time from when the output starts to fall until the output reaches zero volts. | R/W Word | Y | L11 | ms | Y | 8.0 0xD200 |
| TOFF_MAX_WARN_LIMIT | 0x66 | Maximum allowed time, after TOFF_FALL completed, for the unit to decay below 12.5%. | R/W Word | Y | L11 | ms | Y | 150 0xF258 |

TOFF_DELAY

The TOFF_DELAY command sets the time, in milliseconds, from when a stop condition is received until the output voltage starts to fall. Values from 0 to 83 seconds are valid. The resulting turn off delay will have a typical delay of 270 μ s for TOFF_DELAY = 0 and an uncertainty of ± 50 μ s for all values of TOFF_DELAY. TOFF_DELAY is not applied when a fault event occurs

This command has two data bytes and is formatted in Linear_5s_11s format.

PMBus COMMAND DETAILS

TOFF_FALL

The TOFF_FALL command sets the time, in milliseconds, from the end of the turn-off delay time until the output voltage is commanded to zero. It is the ramp time of the V_{OUT} DAC. When the V_{OUT} DAC is zero, the PWM output will be set to high impedance state.

The part will maintain the mode of operation programmed. For defined TOFF_FALL times, the user should set the part to continuous conduction mode. Loading the max value indicates the part will ramp down at the slowest possible rate. The minimum supported fall time is 0.25ms. A value less than 0.25ms will result in a 0.25ms ramp. The maximum fall time is 1.3 seconds. The number of steps in TOFF_FALL is equal to TOFF_FALL (in ms)/0.1ms with an uncertainty of ±0.1ms.

In discontinuous conduction mode, the controller will not draw current from the load and the fall time will be set by the output capacitance and load current.

This command has two data bytes and is formatted in Linear_5s_11s format.

TOFF_MAX_WARN_LIMIT

The TOFF_MAX_WARN_LIMIT command sets the value, in milliseconds, on how long the unit can attempt to turn off the output until a warning is asserted. The output is considered off when the V_{OUT} voltage is less than 12.5% of the programmed VOUT_COMMAND value. The calculation begins after TOFF_FALL is complete.

A data value of 0ms means that there is no limit and that the unit can attempt to turn off the output voltage indefinitely. Other than 0, values from 120ms to 524 seconds are valid.

This command has two data bytes and is formatted in Linear_5s_11s format.

Precondition for Restart

| COMMAND NAME | CMD CODE | DESCRIPTION | TYPE | PAGED | DATA FORMAT | UNITS | EEPROM | DEFAULT VALUE |
|-------------------|----------|--|----------|-------|-------------|-------|--------|---------------|
| MFR_RESTART_DELAY | 0xDC | Minimum time the RUN pin is held low by the LTC3889. | R/W Word | Y | L11 | ms | Y | 500 0xFBE8 |

MFR_RESTART_DELAY

This command specifies the minimum RUN off time in milliseconds. This device will pull the RUN pin low for this length of time once a falling edge of RUN has been detected. The minimum recommended value is 136ms.

Note: The restart delay is different than the retry delay. The restart delay pulls RUN low for the specified time, after which a standard start-up sequence is initiated. The minimum restart delay should be equal to TOFF_DELAY + TOFF_FALL + 136ms. Valid values are from 136ms to 65.52 seconds in 16ms increments. To assure a minimum off time, set the MFR_RESTART_DELAY 16ms longer than the desired time. The output rail can be off longer than the MFR_RESTART_DELAY after the RUN pin is pulled high if the output decay bit 0 is enabled in MFR_CHAN_CONFIG_LTC3889 and the output takes a long time to decay below 12.5% of the programmed value.

This command has two data bytes and is formatted in Linear_5s_11s format.

PMBus COMMAND DETAILS

FAULT RESPONSE

Fault Responses All Faults

| COMMAND NAME | CMD CODE | DESCRIPTION | TYPE | PAGED | DATA FORMAT | UNITS | EEPROM | DEFAULT VALUE |
|-----------------|----------|---|----------|-------|-------------|-------|--------|---------------|
| MFR_RETRY_DELAY | 0xDB | Retry interval during FAULT retry mode. | R/W Word | Y | L11 | ms | Y | 350 0xFABC |

MFR_RETRY_DELAY

This command sets the time in milliseconds between retries if the fault response is to retry the controller at specified intervals. This command value is used for all fault responses that require retry. The retry time starts once the fault has been detected by the offending channel. Valid values are from 120ms to 83.88 seconds in 1ms increments.

Note: The retry delay time is determined by the longer of the MFR_RETRY_DELAY command or the time required for the regulated output to decay below 12.5% of the programmed value. If the natural decay time of the output is too long, it is possible to remove the voltage requirement of the MFR_RETRY_DELAY command by asserting bit 0 of MFR_CHAN_CONFIG_LTC3889.

This command has two data bytes and is formatted in Linear_5s_11s format.

Fault Responses Input Voltage

| COMMAND NAME | CMD CODE | DESCRIPTION | TYPE | PAGED | DATA FORMAT | UNITS | EEPROM | DEFAULT VALUE |
|-----------------------|----------|--|----------|-------|-------------|-------|--------|---------------|
| VIN_OV_FAULT_RESPONSE | 0x56 | Action to be taken by the device when an input supply overvoltage fault is detected. | R/W Byte | Y | Reg | | Y | 0x80 |

VIN_OV_FAULT_RESPONSE

The VIN_OV_FAULT_RESPONSE command instructs the device on what action to take in response to an input overvoltage fault. The data byte is in the format given in Table 11.

The device also:

- Sets the NONE_OF_THE_ABOVE bit in the STATUS_BYTE
- Set the INPUT bit in the upper byte of the STATUS_WORD
- Sets the VIN Overvoltage Fault bit in the STATUS_INPUT command, and
- Notifies the host by asserting $\overline{\text{ALERT}}$ pin, unless masked

This command has one data byte.

Fault Responses Output Voltage

| COMMAND NAME | CMD CODE | DESCRIPTION | TYPE | PAGED | DATA FORMAT | UNITS | EEPROM | DEFAULT VALUE |
|------------------------|----------|---|----------|-------|-------------|-------|--------|---------------|
| VOUT_OV_FAULT_RESPONSE | 0x41 | Action to be taken by the device when an output overvoltage fault is detected. | R/W Byte | Y | Reg | | Y | 0xB8 |
| VOUT_UV_FAULT_RESPONSE | 0x45 | Action to be taken by the device when an output undervoltage fault is detected. | R/W Byte | Y | Reg | | Y | 0xB8 |
| TON_MAX_FAULT_RESPONSE | 0x63 | Action to be taken by the device when a TON_MAX_FAULT event is detected. | R/W Byte | Y | Reg | | Y | 0xB8 |

PMBus COMMAND DETAILS

VOUT_OV_FAULT_RESPONSE

The VOUT_OV_FAULT_RESPONSE command instructs the device on what action to take in response to an output overvoltage fault. The data byte is in the format given in Table 7.

The device also:

- Sets the VOUT_OV bit in the STATUS_BYTE
- Sets the VOUT bit in the STATUS_WORD
- Sets the VOUT Overvoltage Fault bit in the STATUS_VOUT command
- Notifies the host by asserting $\overline{\text{ALERT}}$ pin, unless masked

The only values recognized for this command are:

0x00—Part performs OV pull down only, or OV_PULLDOWN.

0x80—The device shuts down (disables the output) and the unit does not attempt to retry. (PMBus, Part II, Section 10.7).

0xB8—The device shuts down (disables the output) and device attempts to retry continuously, without limitation, until it is commanded OFF (by the RUN pin or OPERATION command or both), bias power is removed, or another fault condition causes the unit to shut down.

0x4n The device shuts down and the unit does not attempt to retry. The output remains disabled until the part is commanded OFF then ON or the RUN pin is asserted low then high or RESET through the command or removal of VIN. The OV fault must remain active for a period of $n \cdot 10\mu\text{s}$, where n is a value from 0 to 7.

0x78+n The device shuts down and the unit attempts to retry continuously until either the fault condition is cleared or the part is commanded OFF then ON or the RUN pin is asserted low then high or RESET through the command or removal of VIN. The OV fault must remain active for a period of $n \cdot 10\mu\text{s}$, where n is a value from 0 to 7.

Any other value will result in a CML fault and the write will be ignored.

This command has one data byte.

Table 7. VOUT_OV_FAULT_RESPONSE Data Byte Contents

| BITS | DESCRIPTION | VALUE | MEANING |
|------|---|-------|---|
| 7:6 | Response For all values of bits [7:6], the LTC3889: <ul style="list-style-type: none"> • Sets the corresponding fault bit in the status commands and • Notifies the host by asserting $\overline{\text{ALERT}}$ pin, unless masked. The fault bit, once set, is cleared only when one or more of the following events occurs: <ul style="list-style-type: none"> • The device receives a CLEAR_FAULTS command. • The output is commanded through the RUN pin, the OPERATION command, or the combined action of the RUN pin and OPERATION command, to turn off and then to turn back on, or • Bias power is removed and reapplied to the LTC3889. | 00 | Part performs OV pull down only or OV_PULLDOWN (i.e., turns off the top MOSFET and turns on lower MOSFET while V_{OUT} is $> V_{\text{OUT_OV_FAULT}}$). |
| | | 01 | The PMBus device continues operation for the delay time specified by bits [2:0] and the delay time unit specified for that particular fault. If the fault condition is still present at the end of the delay time, the unit responds as programmed in the Retry Setting (bits [5:3]). |
| | | 10 | The device shuts down immediately (disables the output) and responds according to the retry setting in bits [5:3]. |
| | | 11 | Not supported. Writing this value will generate a CML fault. |

PMBus COMMAND DETAILS

| BITS | DESCRIPTION | VALUE | MEANING |
|------|---------------|---------|---|
| 5:3 | Retry Setting | 000 | The unit does not attempt to restart. The output remains disabled until the fault is cleared until the device is commanded OFF bias power is removed. |
| | | 111 | The PMBus device attempts to restart continuously, without limitation, until it is commanded OFF (by the RUN pin or OPERATION command or both), bias power is removed, or another fault condition causes the unit to shut down without retry. Note: The retry interval is set by the MFR_RETRY_DELAY command. |
| 2:0 | Delay Time | 000-111 | The delay time in 10 μ s increments. This delay time determines how long the controller continues operating after a fault is detected. Only valid for deglitched off state. |

VOUT_UV_FAULT_RESPONSE

The VOUT_UV_FAULT_RESPONSE command instructs the device on what action to take in response to an output undervoltage fault. The data byte is in the format given in Table 8.

The device also:

- Sets the NONE_OF_THE_ABOVE bit in the STATUS_BYTE
- Sets the VOUT bit in the STATUS_WORD
- Sets the VOUT undervoltage fault bit in the STATUS_VOUT command
- Notifies the host by asserting $\overline{\text{ALERT}}$ pin, unless masked

The UV fault and warn are masked until the following criteria are achieved:

- 1) The TON_MAX_FAULT_LIMIT has been reached
- 2) The TON_DELAY sequence has completed
- 3) The TON_RISE sequence has completed
- 4) The VOUT_UV_FAULT_LIMIT threshold has been reached
- 5) The IOUT_OC_FAULT_LIMIT is not present

The UV fault and warn are masked whenever the channel is not active.

The UV fault and warn are masked during TON_RISE and TOFF_FALL sequencing.

This command has one data byte.

PMBus COMMAND DETAILS

Table 8. VOUT_UV_FAULT_RESPONSE Data Byte Contents

| BITS | DESCRIPTION | VALUE | MEANING |
|------|---|---------|---|
| 7:6 | Response For all values of bits [7:6], the LTC3889: <ul style="list-style-type: none"> • Sets the corresponding fault bit in the status commands and • Notifies the host by asserting $\overline{\text{ALERT}}$ pin, unless masked. The fault bit, once set, is cleared only when one or more of the following events occurs: <ul style="list-style-type: none"> • The device receives a CLEAR_FAULTS command. • The output is commanded through the RUN pin, the OPERATION command, or the combined action of the RUN pin and OPERATION command, to turn off and then to turn back on, or • The device receives a RESTORE_USER_ALL command. • The device receives a MFR_RESET command. • The device supply power is cycled. | 00 | The PMBus device continues operation without interruption. (Ignores the fault functionally) |
| | | 01 | The PMBus device continues operation for the delay time specified by bits [2:0] and the delay time unit specified for that particular fault. If the fault condition is still present at the end of the delay time, the unit responds as programmed in the Retry Setting (bits [5:3]). |
| | | 10 | The device shuts down (disables the output) and responds according to the retry setting in bits [5:3]. |
| | | 11 | Not supported. Writing this value will generate a CML fault. |
| 5:3 | Retry Setting | 000 | The unit does not attempt to restart. The output remains disabled until the fault is cleared until the device is commanded OFF bias power is removed. |
| | | 111 | The PMBus device attempts to restart continuously, without limitation, until it is commanded OFF (by the RUN pin or OPERATION command or both), bias power is removed, or another fault condition causes the unit to shut down without retry. Note: The retry interval is set by the MFR_RETRY_DELAY command. |
| 2:0 | Delay Time | 000-111 | The delay time in 10 μ s increments. This delay time determines how long the controller continues operating after a fault is detected. Only valid for deglitched off state. |

TON_MAX_FAULT_RESPONSE

The TON_MAX_FAULT_RESPONSE command instructs the device on what action to take in response to a TON_MAX fault. The data byte is in the format given in Table 11.

The device also:

- Sets the NONE_OF_THE_ABOVE bit in the STATUS_BYTE
- Sets the VOUT bit in the STATUS_WORD
- Sets the TON_MAX_FAULT bit in the STATUS_VOUT command, and
- Notifies the host by asserting $\overline{\text{ALERT}}$ pin, unless masked

A value of 0 disables the TON_MAX_FAULT_RESPONSE. It is not recommended to use 0.

This command has one data byte.

PMBus COMMAND DETAILS

Fault Responses Output Current

| COMMAND NAME | CMD CODE | DESCRIPTION | TYPE | PAGED | DATA FORMAT | UNITS | EEPROM | DEFAULT VALUE |
|------------------------|----------|--|----------|-------|-------------|-------|--------|---------------|
| IOUT_OC_FAULT_RESPONSE | 0x47 | Action to be taken by the device when an output overcurrent fault is detected. | R/W Byte | Y | Reg | | Y | 0x00 |

IOUT_OC_FAULT_RESPONSE

The IOUT_OC_FAULT_RESPONSE command instructs the device on what action to take in response to an output overcurrent fault. The data byte is in the format given in Figure 9.

The device also:

- Sets the NONE_OF_THE_ABOVE bit in the STATUS_BYTE
- Sets the IOUT_OC bit in the STATUS_BYTE
- Sets the IOUT bit in the STATUS_WORD
- Sets the IOUT Overcurrent Fault bit in the STATUS_IOUT command, and
- Notifies the host by asserting $\overline{\text{ALERT}}$ pin, unless masked

This command has one data byte.

Table 9. IOUT_OC_FAULT_RESPONSE Data Byte Contents

| BITS | DESCRIPTION | VALUE | MEANING |
|------|---|---------|--|
| 7:6 | Response For all values of bits [7:6], the LTC3889: <ul style="list-style-type: none"> • Sets the corresponding fault bit in the status commands and • Notifies the host by asserting $\overline{\text{ALERT}}$ pin, unless masked. The fault bit, once set, is cleared only when one or more of the following events occurs: <ul style="list-style-type: none"> • The device receives a CLEAR_FAULTS command. • The output is commanded through the RUN pin, the OPERATION command, or the combined action of the RUN pin and OPERATION command, to turn off and then to turn back on, or • The device receives a RESTORE_USER_ALL command. • The device receives a MFR_RESET command. • The device supply power is cycled. | 00 | The LTC3889 continues to operate indefinitely while maintaining the output current at the value set by IOUT_OC_FAULT_LIMIT without regard to the output voltage (known as constant-current or brick-wall limiting). |
| | | 01 | Not supported. |
| | | 10 | The LTC3889 continues to operate, maintaining the output current at the value set by IOUT_OC_FAULT_LIMIT without regard to the output voltage, for the delay time set by bits [2:0]. If the device is still operating in current limit at the end of the delay time, the device responds as programmed by the Retry Setting in bits [5:3]. |
| | | 11 | The LTC3889 shuts down immediately and responds as programmed by the Retry Setting in bits [5:3]. |
| 5:3 | Retry Setting | 000 | The unit does not attempt to restart. The output remains disabled until the fault is cleared by cycling the RUN pin or removing bias power. |
| | | 111 | The device attempts to restart continuously, without limitation, until it is commanded OFF (by the RUN pin or OPERATION command or both), bias power is removed, or another fault condition causes the unit to shut down. Note: The retry interval is set by the MFR_RETRY_DELAY command. |
| 2:0 | Delay Time | 000-111 | The number of delay time units in 16ms increments. This delay time is used to determine the amount of time a unit is to continue operating after a fault is detected before shutting down. Only valid for deglitched off response. |

PMBus COMMAND DETAILS

Fault Responses IC Temperature

| COMMAND NAME | CMD CODE | DESCRIPTION | TYPE | PAGED | DATA FORMAT | UNITS | EEPROM | DEFAULT VALUE |
|-----------------------|----------|--|--------|-------|-------------|-------|--------|---------------|
| MFR_OT_FAULT_RESPONSE | 0xD6 | Action to be taken by the device when an internal overtemperature fault is detected. | R Byte | N | Reg | | | 0xC0 |

MFR_OT_FAULT_RESPONSE

The MFR_OT_FAULT_RESPONSE command byte instructs the device on what action to take in response to an internal overtemperature fault. The data byte is in the format given in Table 10.

The LTC3889 also:

- Sets the NONE_OF_THE_ABOVE bit in the STATUS_BYTE
- Sets the MFR bit in the STATUS_WORD, and
- Sets the Overtemperature Fault bit in the STATUS_MFR_SPECIFIC command
- Notifies the host by asserting $\overline{\text{ALERT}}$ pin, unless masked

This command has one data byte.

Table 10. Data Byte Contents MFR_OT_FAULT_RESPONSE

| BITS | DESCRIPTION | VALUE | MEANING |
|------|---|---------|--|
| 7:6 | Response For all values of bits [7:6], the LTC3889: <ul style="list-style-type: none"> • Sets the corresponding fault bit in the status commands and • Notifies the host by asserting $\overline{\text{ALERT}}$ pin, unless masked. The fault bit, once set, is cleared only when one or more of the following events occurs: <ul style="list-style-type: none"> • The device receives a CLEAR_FAULTS command. • The output is commanded through the RUN pin, the OPERATION command, or the combined action of the RUN pin and OPERATION command, to turn off and then to turn back on, or • Bias power is removed and reapplied to the LTC3889. | 00 | Not supported. Writing this value will generate a CML fault. |
| | | 01 | Not supported. Writing this value will generate a CML fault |
| | | 10 | The device shuts down immediately (disables the output) and responds according to the retry setting in bits [5:3]. |
| | | 11 | The device's output is disabled while the fault is present. Operation resumes and the output is enabled when the fault condition no longer exists. |
| 5:3 | Retry Setting | 000 | The unit does not attempt to restart. The output remains disabled until the fault is cleared. |
| | | 001-111 | Not supported. Writing this value will generate CML fault. |
| 2:0 | Delay Time | XXX | Not supported. Value ignored |

PMBus COMMAND DETAILS

Fault Responses External Temperature

| COMMAND NAME | CMD CODE | DESCRIPTION | TYPE | PAGED | DATA FORMAT | UNITS | EEPROM | DEFAULT VALUE |
|-------------------|----------|---|----------|-------|-------------|-------|--------|---------------|
| OT_FAULT_RESPONSE | 0x50 | Action to be taken by the device when an external overtemperature fault is detected, | R/W Byte | Y | Reg | | Y | 0xB8 |
| UT_FAULT_RESPONSE | 0x54 | Action to be taken by the device when an external undertemperature fault is detected. | R/W Byte | Y | Reg | | Y | 0xB8 |

OT_FAULT_RESPONSE

The OT_FAULT_RESPONSE command instructs the device on what action to take in response to an external overtemperature fault on the external temp sensors. The data byte is in the format given in Table 11.

The device also:

- Sets the TEMPERATURE bit in the STATUS_BYTE
- Sets the Overtemperature Fault bit in the STATUS_TEMPERATURE command, and
- Notifies the host by asserting $\overline{\text{ALERT}}$ pin, unless masked

This command has one data byte.

UT_FAULT_RESPONSE

The UT_FAULT_RESPONSE command instructs the device on what action to take in response to an external undertemperature fault on the external temp sensors. The data byte is in the format given in Table 11.

The device also:

- Sets the TEMPERATURE bit in the STATUS_BYTE
- Sets the Undertemperature Fault bit in the STATUS_TEMPERATURE command, and
- Notifies the host by asserting $\overline{\text{ALERT}}$ pin, unless masked

This condition is detected by the ADC so the response time may be up to 90ms.

This command has one data byte.

PMBus COMMAND DETAILS

Table 11. Data Byte Contents: TON_MAX_FAULT_RESPONSE, VIN_OV_FAULT_RESPONSE, OT_FAULT_RESPONSE, UT_FAULT_RESPONSE

| BITS | DESCRIPTION | VALUE | MEANING |
|------|--|-------|---|
| 7:6 | Response For all values of bits [7:6], the LTC3889: <ul style="list-style-type: none"> • Sets the corresponding fault bit in the status commands, and • Notifies the host by asserting $\overline{\text{ALERT}}$ pin, unless masked. The fault bit, once set, is cleared only when one or more of the following events occurs: <ul style="list-style-type: none"> • The device receives a CLEAR_FAULTS command. • The output is commanded through the RUN pin, the OPERATION command, or the combined action of the RUN pin and OPERATION command, to turn off and then to turn back on, or • The device receives a RESTORE_USER_ALL command. • The device receives a MFR_RESET command. • The device supply power is cycled. | 00 | The PMBus device continues operation without interruption. |
| | | 01 | Not supported. Writing this value will generate a CML fault. |
| | | 10 | The device shuts down immediately (disables the output) and responds according to the retry setting in bits [5:3]. |
| | | 11 | Not supported. Writing this value will generate a CML fault. |
| 5:3 | Retry Setting | 000 | The unit does not attempt to restart. The output remains disabled until the fault is cleared until the device is commanded OFF bias power is removed. |
| | | 111 | The PMBus device attempts to restart continuously, without limitation, until it is commanded OFF (by the RUN pin or OPERATION command or both), bias power is removed, or another fault condition causes the unit to shut down without retry. Note: The retry interval is set by the MFR_RETRY_DELAY command. |
| 2:0 | Delay Time | XXX | Not supported. Values ignored |

FAULT SHARING

Fault Sharing Propagation

| COMMAND NAME | CMD CODE | DESCRIPTION | TYPE | PAGED | DATA FORMAT | UNITS | EEPROM | DEFAULT VALUE |
|-----------------------------|----------|--|----------|-------|-------------|-------|--------|---------------|
| MFR_FAULT_PROPAGATE_LTC3889 | 0xD2 | Configuration that determines which faults are propagated to the FAULT pins. | R/W Word | Y | Reg | | Y | 0x6993 |

MFR_FAULT_PROPAGATE_LTC3889

The MFR_FAULT_PROPAGATE_LTC3889 command enables the faults that can cause the $\overline{\text{FAULT}}_n$ pin to assert low. The command is formatted as shown in Table 12. Faults can only be propagated to the $\overline{\text{FAULT}}_n$ pin if they are programmed to respond to faults.

This command has two data bytes.

PMBus COMMAND DETAILS

Table 12. FAULT_n Propagate Fault Configuration

The FAULT₀ and FAULT₁ pins are designed to provide electrical notification of selected events to the user. Some of these events are common to both output channels. Others are specific to an output channel. They can also be used to share faults between channels.

| BIT(S) | SYMBOL | OPERATION |
|--------|---|--|
| B[15] | VOUT disabled while not decayed. | This is used in a PolyPhase configuration when bit 0 of the MFR_CHAN_CONFIG_LTC3889 is a zero. If the channel is turned off, by toggling the RUN pin or commanding the part OFF, and then the RUN is reasserted or the part is commanded back on before the output has decayed, VOUT will not restart until the 12.5% decay is honored. The FAULT pin is asserted during this condition if bit 15 is asserted. |
| B[14] | Mfr_FAULT_propagate_short_CMD_cycle | 0: No action 1: Asserts low if commanded off then on before the output has sequenced off. Re-asserts high 120ms after sequence off. |
| b[13] | Mfr_FAULT_propagate_ton_max_fault | 0: No action if a TON_MAX_FAULT fault is asserted 1: Associated output will be asserted low if a TON_MAX_FAULT fault is asserted FAULT ₀ is associated with page 0 TON_MAX_FAULT faults FAULT ₁ is associated with page 1 TON_MAX_FAULT faults |
| b[12] | Reserved | Must be 0 |
| b[11] | Mfr_FAULT ₀ _propagate_int_ot, Mfr_FAULT ₁ _propagate_int_ot | 0: No action if the MFR_OT_FAULT_LIMIT fault is asserted 1: Associated output will be asserted low if the MFR_OT_FAULT_LIMIT fault is asserted |
| b[10] | Reserved | Must be 0 |
| b[9] | Reserved | Must be 0 |
| b[8] | Mfr_FAULT ₀ _propagate_ut, Mfr_FAULT ₁ _propagate_ut | 0: No action if the UT_FAULT_LIMIT fault is asserted 1: Associated output will be asserted low if the UT_FAULT_LIMIT fault is asserted FAULT ₀ is associated with page 0 UT faults FAULT ₁ is associated with page 1 UT faults |
| b[7] | Mfr_FAULT ₀ _propagate_ot, Mfr_FAULT ₁ _propagate_ot | 0: No action if the OT_FAULT_LIMIT fault is asserted 1: Associated output will be asserted low if the OT_FAULT_LIMIT fault is asserted FAULT ₀ is associated with page 0 OT faults FAULT ₁ is associated with page 1 OT faults |
| b[6] | Reserved | |
| b[5] | Reserved | |
| b[4] | Mfr_FAULT ₀ _propagate_input_ov, Mfr_FAULT ₁ _propagate_input_ov | 0: No action if the VIN_OV_FAULT_LIMIT fault is asserted 1: Associated output will be asserted low if the VIN_OV_FAULT_LIMIT fault is asserted |
| b[3] | Reserved | |
| b[2] | Mfr_FAULT ₀ _propagate_iout_oc, Mfr_FAULT ₁ _propagate_iout_oc | 0: No action if the IOUT_OC_FAULT_LIMIT fault is asserted 1: Associated output will be asserted low if the IOUT_OC_FAULT_LIMIT fault is asserted FAULT ₀ is associated with page 0 OC faults FAULT ₁ is associated with page 1 OC faults |
| b[1] | Mfr_FAULT ₀ _propagate_vout_uv, Mfr_FAULT ₁ _propagate_vout_uv | 0: No action if the VOUT_UV_FAULT_LIMIT fault is asserted 1: Associated output will be asserted low if the VOUT_UV_FAULT_LIMIT fault is asserted FAULT ₀ is associated with page 0 UV faults FAULT ₁ is associated with page 1 UV faults |
| b[0] | Mfr_FAULT ₀ _propagate_vout_ov, Mfr_FAULT ₁ _propagate_vout_ov | 0: No action if the VOUT_OV_FAULT_LIMIT fault is asserted 1: Associated output will be asserted low if the VOUT_OV_FAULT_LIMIT fault is asserted FAULT ₀ is associated with page 0 OV faults FAULT ₁ is associated with page 1 OV faults |

PMBus COMMAND DETAILS

Fault Sharing Response

| COMMAND NAME | CMD CODE | DESCRIPTION | TYPE | PAGED | DATA FORMAT | UNITS | EEPROM | DEFAULT VALUE |
|--------------------|----------|--|----------|-------|-------------|-------|--------|---------------|
| MFR_FAULT_RESPONSE | 0xD5 | Action to be taken by the device when the FAULT pin is asserted low. | R/W Byte | Y | Reg | | Y | 0xC0 |

MFR_FAULT_RESPONSE

The MFR_FAULT_RESPONSE command instructs the device on what action to take in response to the $\overline{\text{FAULT}}_n$ pin being pulled low by an external source.

Supported Values:

| VALUE | MEANING |
|-------|--|
| 0xC0 | FAULT_INHIBIT The LTC3889 will disable the respective PWM channel in response to the $\overline{\text{FAULT}}$ pin pulled low. |
| 0x00 | FAULT_IGNORE The LTC3889 continues operation without interruption. |

The device also:

- Sets the MFR_SPECIFIC Bit in the STATUS_WORD.
- Sets Bit 0 in the STATUS_MFR_SPECIFIC Command to Indicate $\overline{\text{FAULT}}_n$ Is Being Pulled Low
- Notifies the Host by Asserting $\overline{\text{ALERT}}$, Unless Masked

This command has one data byte.

SCRATCHPAD

| COMMAND NAME | CMD CODE | DESCRIPTION | TYPE | PAGED | DATA FORMAT | UNITS | EEPROM | DEFAULT VALUE |
|--------------|----------|--|----------|-------|-------------|-------|--------|---------------|
| USER_DATA_00 | 0xB0 | OEM reserved. Typically used for part serialization. | R/W Word | N | Reg | | Y | NA |
| USER_DATA_01 | 0xB1 | Manufacturer reserved for LTpowerPlay. | R/W Word | Y | Reg | | Y | NA |
| USER_DATA_02 | 0xB2 | OEM reserved. Typically used for part serialization. | R/W Word | N | Reg | | Y | NA |
| USER_DATA_03 | 0xB3 | A EEPROM word available for the user. | R/W Word | Y | Reg | | Y | 0x0000 |
| USER_DATA_04 | 0xB4 | A EEPROM word available for the user. | R/W Word | N | Reg | | Y | 0x0000 |

USER_DATA_00 through ***USER_DATA_04***

These commands are non-volatile memory locations for customer storage. The customer has the option to write any value to the USER_DATA_nn at any time. However, the LTpowerPlay software and contract manufacturers use some of these commands for inventory control. Modifying the reserved USER_DATA_nn commands may lead to undesirable inventory control and incompatibility with these products.

These commands have 2 data bytes and are in register format.

PMBus COMMAND DETAILS

IDENTIFICATION

| COMMAND NAME | CMD CODE | DESCRIPTION | TYPE | PAGED | DATA FORMAT | UNITS | EEPROM | DEFAULT VALUE |
|----------------|----------|---|----------|-------|-------------|-------|--------|---------------|
| PMBUS_REVISION | 0x98 | PMBus revision supported by this device. Current revision is 1.2. | R Byte | N | Reg | | FS | 0x22 |
| CAPABILITY | 0x19 | Summary of PMBus optional communication protocols supported by this device. | R Byte | N | Reg | | | 0xB0 |
| MFR_ID | 0x99 | The manufacturer ID of the LTC3889 in ASCII. | R String | N | ASC | | | LTC |
| MFR_MODEL | 0x9A | Manufacturer part number in ASCII. | R String | N | ASC | | | LTC3889 |
| MFR_SPECIAL_ID | 0xE7 | Manufacturer code representing the LTC3889. | R Word | N | Reg | | | 0x490X |
| IC_DEVICE_ID | 0xAD | Identification of the IC | R Block | N | Reg | | Y | |
| IC_DEVICE_REV | 0xAE | Revision of the IC | R Block | N | Reg | | Y | |

PMBus_REVISION

The PMBUS_REVISION command indicates the revision of the PMBus to which the device is compliant. The LTC3889 is PMBus Version 1.2 compliant in both Part I and Part II.

This read-only command has one data byte.

CAPABILITY

This command provides a way for a host system to determine some key capabilities of a PMBus device.

The LTC3889 supports packet error checking, 400kHz bus speeds, and $\overline{\text{ALERT}}$ pin.

This read-only command has one data byte.

MFR_ID

The MFR_ID command indicates the manufacturer ID of the LTC3889 using ASCII characters.

This read-only command is in block format.

MFR_MODEL

The MFR_MODEL command indicates the manufacturer's part number of the LTC3889 using ASCII characters.

This read-only command is in block format.

MFR_SPECIAL_ID

The 16-bit word representing the part name and revision. 0x49 denotes the part is an LTC3889, X is adjustable by the manufacturer.

This read-only command has two data bytes.

IC_DEVICE_ID

The IC_DEVICE_ID command indicates the manufacturer's ID of the LTC3889 using ASCII characters.

This read-only command is in block format.

PMBus COMMAND DETAILS

IC_DEVICE_REV

The IC_DEVICE_REV command indicates the revision of the LTC3889 using ASCII characters.

This read-only command is in block format.

FAULT WARNING AND STATUS

| COMMAND NAME | CMD CODE | DESCRIPTION | TYPE | PAGED | FORMAT | UNITS | EEPROM | DEFAULT VALUE |
|---------------------|----------|---|-----------|-------|--------|-------|--------|-----------------|
| CLEAR_FAULTS | 0x03 | Clear any fault bits that have been set. | Send Byte | N | | | | NA |
| SMBALERT_MASK | 0x1B | Mask activity. | Block R/W | Y | Reg | | Y | See CMD Details |
| MFR_CLEAR_PEAKE | 0xE3 | Clears all peak values. | Send Byte | N | | | | NA |
| STATUS_BYTE | 0x78 | One byte summary of the unit's fault condition. | R/W Byte | Y | Reg | | | NA |
| STATUS_WORD | 0x79 | Two byte summary of the unit's fault condition. | R/W Word | Y | Reg | | | NA |
| STATUS_VOUT | 0x7A | Output voltage fault and warning status. | R/W Byte | Y | Reg | | | NA |
| STATUS_IOUT | 0x7B | Output current fault and warning status. | R/W Byte | Y | Reg | | | NA |
| STATUS_INPUT | 0x7C | Input supply fault and warning status. | R/W Byte | N | Reg | | | NA |
| STATUS_TEMPERATURE | 0x7D | External temperature fault and warning status for READ_TEMPERATURE_1. | R/W Byte | Y | Reg | | | NA |
| STATUS_CML | 0x7E | Communication and memory fault and warning status. | R/W Byte | N | Reg | | | NA |
| STATUS_MFR_SPECIFIC | 0x80 | Manufacturer specific fault and state information. | R/W Byte | Y | Reg | | | NA |
| MFR_PADS | 0xE5 | Digital status of the I/O pads. | R Word | N | Reg | | | NA |
| MFR_COMMON | 0xEF | Manufacturer status bits that are common across multiple ADI chips. | R Byte | N | Reg | | | NA |
| MFR_INFO | 0xB6 | Manufacturing specific information. | R Word | N | Reg | | | NA |

CLEAR_FAULTS

The CLEAR_FAULTS command is used to clear any fault bits that have been set. This command clears all bits in all status commands simultaneously. At the same time, the device negates (clears, releases) its $\overline{\text{ALERT}}$ pin signal output if the device is asserting the $\overline{\text{ALERT}}$ pin signal. If the fault is still present when the bit is cleared, the fault bit will remain set and the host notified by asserting the $\overline{\text{ALERT}}$ pin low. CLEAR_FAULTS can take up to 10 μ s to process. If a fault occurs within that time frame it may be cleared before the status register is set.

This write-only command has no data bytes.

The CLEAR_FAULTS does not cause a unit that has latched off for a fault condition to restart. Units that have shut down for a fault condition are restarted when:

- The output is commanded through the RUN pin, the OPERATION command, or the combined action of the RUN pin and OPERATION command, to turn off and then to turn back on, or
- MFR_RESET command is issued.
- Bias power is removed and reapplied to the integrated circuit

PMBus COMMAND DETAILS

SMBALERT_MASK

The SMBALERT_MASK command can be used to prevent a particular status bit or bits from asserting $\overline{\text{ALERT}}$ as they are asserted.

Figure 47 shows an example of the Write Word format used to set an $\overline{\text{ALERT}}$ mask, in this case without PEC. The bits in the mask byte align with bits in the specified status register. For example, if the STATUS_TEMPERATURE command code is sent in the first data byte, and the mask byte contains 0x40, then a subsequent External Overtemperature Warning would still set bit 6 of STATUS_TEMPERATURE but not assert $\overline{\text{ALERT}}$. All other supported STATUS_TEMPERATURE bits would continue to assert $\overline{\text{ALERT}}$ if set.

Figure 48 shows an example of the Block Write – Block Read Process Call protocol used to read back the present state of any supported status register, again without PEC.

SMBALERT_MASK cannot be applied to STATUS_BYTE, STATUS_WORD, MFR_COMMON or MFR_PADS. Factory default masking for applicable status registers is shown below. Providing an unsupported command code to SMBALERT_MASK will generate a CML for Invalid/Unsupported Data.

SMBALERT_MASK Default Setting: (Refer Also to Figure 2)

| STATUS RESISTER | ALERT Mask Value | MASKED BITS |
|---------------------|------------------|---|
| STATUS_VOUT | 0x00 | None |
| STATUS_IOUT | 0x00 | None |
| STATUS_TEMPERATURE | 0x00 | None |
| STATUS_CML | 0x00 | None |
| STATUS_INPUT | 0x00 | None |
| STATUS_MFR_SPECIFIC | 0x11 | Bit 4 (internal PLL unlocked), bit 0 ($\overline{\text{FAULT}}$ pulled low by external device) |

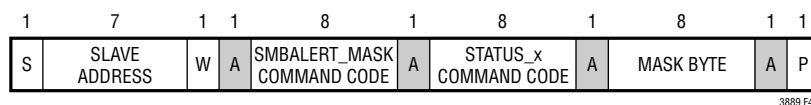

Figure 47. Example of Setting SMBALERT_MASK

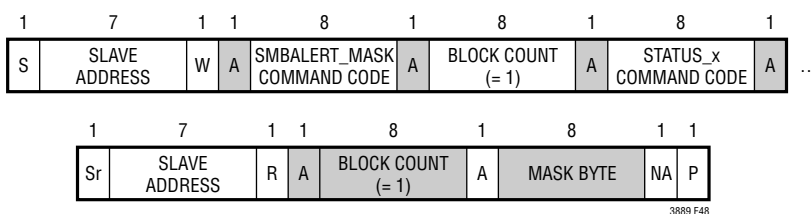

Figure 48. Example of Reading SMBALERT_MASK

PMBus COMMAND DETAILS

MFR_CLEAR_PEAKS

The MFR_CLEAR_PEAKS command clears the MFR_*_PEAK data values. A MFR_RESET command will also clear the MFR_*_PEAK data values.

This write-only command has no data bytes.

STATUS_BYTE

The STATUS_BYTE command returns one byte of information with a summary of the most critical faults. This is the lower byte of the status word.

STATUS_BYTE Message Contents:

| BIT | STATUS BIT NAME | MEANING |
|-----|-------------------|--|
| 7* | BUSY | A fault was declared because the LTC3889 was unable to respond. |
| 6 | OFF | This bit is set if the channel is not providing power to its output, regardless of the reason, including simply not being enabled. |
| 5 | VOUT_OV | An output overvoltage fault has occurred. |
| 4 | IOUT_OC | An output overcurrent fault has occurred. |
| 3 | VIN_UV | Not supported (LTC3889 returns 0). |
| 2 | TEMPERATURE | A temperature fault or warning has occurred. |
| 1 | CML | A communications, memory or logic fault has occurred. |
| 0* | NONE OF THE ABOVE | A fault Not listed in bits[7:1] has occurred. |

*ALERT can be asserted if either of these bits is set. They may be cleared by writing a 1 to their bit position in the STATUS_BYTE, in lieu of a CLEAR_FAULTS command.

This command has one data byte.

STATUS_WORD

The STATUS_WORD command returns a two-byte summary of the channel's fault condition. The low byte of the STATUS_WORD is the same as the STATUS_BYTE command.

STATUS_WORD High Byte Message Contents:

| BIT | STATUS BIT NAME | MEANING |
|-----|------------------|--|
| 15 | V _{OUT} | An output voltage fault or warning has occurred. |
| 14 | I _{OUT} | An output current fault or warning has occurred. |
| 13 | INPUT | An input voltage fault or warning has occurred. |
| 12 | MFR_SPECIFIC | A fault or warning specific to the LTC3889 has occurred. |
| 11 | POWER_GOOD# | The POWER_GOOD state is false if this bit is set. |
| 10 | FANS | Not supported (LTC3889 returns 0). |
| 9 | OTHER | Not supported (LTC3889 returns 0). |
| 8 | UNKNOWN | Not supported (LTC3889 returns 0). |

If any of the bits in the upper byte are set, NONE_OF_THE_ABOVE is asserted.

This command has two data bytes.

PMBus COMMAND DETAILS

STATUS_VOUT

The STATUS_VOUT command returns one byte of V_{OUT} status information.

STATUS_VOUT Message Contents:

| BIT | MEANING |
|-----|------------------------------------|
| 7 | V_{OUT} overvoltage fault. |
| 6 | V_{OUT} overvoltage warning. |
| 5 | V_{OUT} undervoltage warning. |
| 4 | V_{OUT} undervoltage fault. |
| 3 | V_{OUT} max warning. |
| 2 | TON max fault. |
| 1 | TOFF max fault. |
| 0 | Not supported (LTC3889 returns 0). |

The user is permitted to write a 1 to any bit in this command to clear a specific fault. This permits the user to clear status by means other than using the CLEAR_FAULTS command.

Any supported fault bit in this command will initiate an $\overline{\text{ALERT}}$ event.

This command has one data byte.

STATUS_IOUT

The STATUS_IOUT command returns one byte of I_{OUT} status information.

STATUS_IOUT Message Contents:

| BIT | MEANING |
|-----|------------------------------------|
| 7 | I_{OUT} overcurrent fault. |
| 6 | Not supported (LTC3889 returns 0). |
| 5 | I_{OUT} overcurrent warning. |
| 4:0 | Not supported (LTC3889 returns 0). |

The user is permitted to write a 1 to any bit in this command to clear a specific fault. This permits the user to clear status by means other than using the CLEAR_FAULTS command.

Any supported fault bit in this command will initiate an $\overline{\text{ALERT}}$ event. This command has one data byte.

PMBus COMMAND DETAILS

STATUS_INPUT

The STATUS_INPUT command returns one byte of V_{IN} (VINSNS) status information.

STATUS_INPUT Message Contents:

| BIT | MEANING |
|-----|--------------------------------------|
| 7 | V_{IN} overvoltage fault. |
| 6 | Not supported (LTC3889 returns 0). |
| 5 | V_{IN} undervoltage warning. |
| 4 | Not supported (LTC3889 returns 0). |
| 3 | Unit off for insufficient V_{IN} . |
| 2 | Not supported (LTC3889 returns 0). |
| 1 | I_{IN} overcurrent warning. |
| 0 | Not supported (LTC3889 returns 0). |

The user is permitted to write a 1 to any bit in this command to clear a specific fault. This permits the user to clear status by means other than using the CLEAR_FAULTS command.

Any supported fault bit in this command will initiate an $\overline{\text{ALERT}}$ event. Bit 3 of this command is not latched and will not generate an $\overline{\text{ALERT}}$ even if it is set. This command has one data byte.

STATUS_TEMPERATURE

The STATUS_TEMPERATURE commands returns one byte with status information on temperature. This is a paged command and is related to the respective READ_TEMPERATURE_1 value.

STATUS_TEMPERATURE Message Contents:

| BIT | MEANING |
|-----|------------------------------------|
| 7 | External overtemperature fault. |
| 6 | External overtemperature warning. |
| 5 | Not supported (LTC3889 returns 0). |
| 4 | External undertemperature fault. |
| 3:0 | Not supported (LTC3889 returns 0). |

The user is permitted to write a 1 to any bit in this command to clear a specific fault. This permits the user to clear status by means other than using the CLEAR_FAULTS command.

This command has one data byte.

PMBus COMMAND DETAILS

STATUS_CML

The STATUS_CML command returns one byte of status information on received commands, internal memory and logic.

STATUS_CML Message Contents:

| BIT | MEANING |
|-----|--|
| 7 | Invalid or unsupported command received. |
| 6 | Invalid or unsupported data received. |
| 5 | Packet error check failed. |
| 4 | Memory fault detected. |
| 3 | Processor fault detected. |
| 2 | Reserved (LTC3889 returns 0). |
| 1 | Other communication fault. |
| 0 | Other memory or logic fault. |

If either bit 3 or bit 4 of this command is set, a serious and significant internal error has been detected. Continued operation of the part is not recommended if these bits are continuously set.

The user is permitted to write a 1 to any bit in this command to clear a specific fault. This permits the user to clear status by means other than using the CLEAR_FAULTS command.

Any supported fault bit in this command will initiate an $\overline{\text{ALERT}}$ event.

This command has one data byte.

STATUS_MFR_SPECIFIC

The STATUS_MFR_SPECIFIC commands returns one byte with the manufacturer specific status information.

The format for this byte is:

| BIT | MEANING |
|-----|---|
| 7 | Internal Temperature Fault Limit Exceeded. |
| 6 | Internal Temperature Warn Limit Exceeded. |
| 5 | Factory Trim Area EEPROM CRC Fault. |
| 4 | PLL is Unlocked |
| 3 | Fault Log Present |
| 2 | V _{DD33} UV or OV Fault |
| 0 | $\overline{\text{FAULT}}$ Pin Asserted Low by External Device |

If any of these bits are set, the MFR bit in the STATUS_WORD will be set, and $\overline{\text{ALERT}}$ may be asserted.

The user is permitted to write a 1 to any bit in this command to clear a specific fault. This permits the user to clear status by means other than using the CLEAR_FAULTS command. However, the fault log present bit can only be cleared by issuing the MFR_FAULT_LOG_CLEAR command.

Any supported fault bit in this command will initiate an $\overline{\text{ALERT}}$ event.

This command has one data byte.

PMBus COMMAND DETAILS

MFR_PADS

This command provides the user a means of directly reading the digital status of the I/O pins of the device. The bit assignments of this command are as follows:

| BIT | ASSIGNED DIGITAL PIN |
|-----|---|
| 15 | V _{DD33} OV Fault |
| 14 | V _{DD33} UV Fault |
| 13 | Reserved |
| 12 | Reserved |
| 11 | ADC Values Invalid, Occurs During Start-Up. May Occur Briefly on Current Measurement Channels During Normal Operation |
| 10 | SYNC clocked by external device (when LTC3889 configured to drive SYNC pin) |
| 9 | Channel 1 Power Good |
| 8 | Channel 0 Power Good |
| 7 | LTC3889 Driving RUN1 Low |
| 6 | LTC3889 Driving RUN0 Low |
| 5 | RUN1 Pin State |
| 4 | RUN0 Pin State |
| 3 | LTC3889 Driving FAULT1 Low |
| 2 | LTC3889 Driving FAULT0 Low |
| 1 | FAULT1 Pin State |
| 0 | FAULT0 Pin State |

A 1 indicates the condition is true.

This read-only command has two data bytes.

MFR_COMMON

The MFR_COMMON command contains bits that are common to all ADI digital power and telemetry products.

| BIT | MEANING |
|-----|-----------------------------------|
| 7 | Chip Not Driving ALERT Low |
| 6 | LTC3889 Not Busy |
| 5 | Calculations Not Pending |
| 4 | LTC3889 Outputs Not in Transition |
| 3 | EEPROM Initialized |
| 2 | Reserved |
| 1 | SHARE_CLK Timeout |
| 0 | WP Pin Status |

This read-only command has one data byte.

PMBus COMMAND DETAILS

MFR_INFO

The MFR_INFO command contains the EEPROM status bit.

MFR_INFO Data Contents

| BIT | MEANING |
|------|--|
| 15:6 | Reserved |
| 5 | EEPROM ECC status |
| 0b | Corrections made in the EEPROM user space |
| 1b | No corrections made in the EEPROM user space |
| 4:0 | Reserved |

EEPROM ECC status is updated after each RESTORE_USER_ALL or RESET command, a power-on reset or a EEPROM bulk read operation. This read-only command has two data bytes.

TELEMETRY

| COMMAND NAME | CMD CODE | DESCRIPTION | TYPE | PAGED | FORMAT | UNITS | EEPROM | DEFAULT VALUE |
|------------------------|----------|--|----------|-------|--------|-------|--------|---------------|
| READ_VIN | 0x88 | Measured input supply voltage. | R Word | N | L11 | V | | NA |
| READ_IIN | 0x89 | Measured input supply current. | R Word | N | L11 | A | | NA |
| READ_VOUT | 0x8B | Measured output voltage. | R Word | Y | L16 | V | | NA |
| READ_IOUT | 0x8C | Measured output current. | R Word | Y | L11 | A | | NA |
| READ_TEMPERATURE_1 | 0x8D | External diode junction temperature. This is the value used for all temperature related processing, including IOUT_CAL_GAIN. | R Word | Y | L11 | C | | NA |
| READ_TEMPERATURE_2 | 0x8E | Internal junction temperature. Does not affect any other commands. | R Word | N | L11 | C | | NA |
| READ_FREQUENCY | 0x95 | Measured PWM switching frequency. | R Word | Y | L11 | kHz | | NA |
| READ_POUT | 0x96 | Calculated output power. | R Word | Y | L11 | W | | NA |
| READ_PIN | 0x97 | Calculated input power. | R Word | N | L11 | W | | NA |
| MFR_IOUT_PEAK | 0xD7 | Report the maximum measured value of READ_IOUT since last MFR_CLEAR_PEAKS. | R Word | Y | L11 | A | | NA |
| MFR_ADC_CONTROL | 0xD8 | ADC telemetry parameter selected for repeated fast ADC read back | R/W Byte | N | Reg | | | 0x00 |
| MFR_VOUT_PEAK | 0xDD | Maximum measured value of READ_VOUT since last MFR_CLEAR_PEAKS. | R Word | Y | L16 | V | | NA |
| MFR_VIN_PEAK | 0xDE | Maximum measured value of READ_VIN since last MFR_CLEAR_PEAKS. | R Word | N | L11 | V | | NA |
| MFR_TEMPERATURE_1_PEAK | 0xDF | Maximum measured value of external Temperature (READ_TEMPERATURE_1) since last MFR_CLEAR_PEAKS. | R Word | Y | L11 | C | | NA |
| MFR_READ_IIN_PEAK | 0xE1 | Maximum measured value of READ_IIN command since last MFR_CLEAR_PEAKS. | R Word | N | L11 | A | | NA |
| MFR_READ_ICHIP | 0xE4 | Measured current used by the LTC3889. | R Word | N | L11 | A | | NA |
| MFR_TEMPERATURE_2_PEAK | 0xF4 | Peak internal die temperature since last MFR_CLEAR_PEAKS. | R Word | N | L11 | C | | NA |

READ_VIN

The READ_VIN command returns the measured V_{IN} pin voltage, in volts added to $READ_ICHIP \cdot MFR_RVIN$. This compensates for the IR voltage drop across the V_{IN} filter element due to the supply current of the LTC3889.

PMBus COMMAND DETAILS

This read-only command has two data bytes and is formatted in Linear_5s_11s format.

READ_VOUT

The READ_VOUT command returns the measured output voltage in the same format as set by the VOUT_MODE command.

This read-only command has two data bytes and is formatted in Linear_16u format.

READ_IIN

The READ_IIN command returns the input current, in Amperes, as measured across the input current sense resistor (see also MFR_IIN_CAL_GAIN).

This read-only command has two data bytes and is formatted in Linear_5s_11s format.

READ_IOUT

The READ_IOUT command returns the average output current in amperes. The IOUT value is a function of:

- a) the differential voltage measured across the I_{SENSE} pins
- b) the IOUT_CAL_GAIN value
- c) the MFR_IOUT_CAL_GAIN_TC value, and
- d) READ_TEMPERATURE_1 value
- e) The MFR_TEMP_1_GAIN and the MFR_TEMP_1_OFFSET

This read-only command has two data bytes and is formatted in Linear_5s_11s format.

READ_TEMPERATURE_1

The READ_TEMPERATURE_1 command returns the temperature, in degrees Celsius, of the external sense element.

This read-only command has two data bytes and is formatted in Linear_5s_11s format.

READ_TEMPERATURE_2

The READ_TEMPERATURE_2 command returns the LTC3889's die temperature, in degrees Celsius, of the internal sense element.

This read-only command has two data bytes and is formatted in Linear_5s_11s format.

READ_FREQUENCY

The READ_FREQUENCY command is a reading of the PWM switching frequency in kHz.

This read-only command has 2 data bytes and is formatted in Linear_5s_11s format.

READ_POUT

The READ_POUT command is a reading of the DC/DC converter output power in Watts. POUT is calculated based on the most recent correlated output voltage and current reading.

This read-only command has 2 data bytes and is formatted in Linear_5s_11s format.

PMBus COMMAND DETAILS

READ_PIN

The READ_PIN command is a reading of the DC/DC converter input power in Watts. PIN is calculated based on the most recent input voltage and current reading.

This read-only command has 2 data bytes and is formatted in Linear_5s_11s format.

MFR_IOUT_PEAK

The MFR_IOUT_PEAK command reports the highest current, in amperes, reported by the READ_IOUT measurement.

This command is cleared using the MFR_CLEAR_PEAKS command.

This read-only command has two data bytes and is formatted in Linear_5s_11s format.

MFR_ADC_CONTROL

The MFR_ADC_CONTROL command determines the ADC read back selection. A default value of 0 in the command runs the standard telemetry loop with all parameters updated in a round robin fashion with a typical latency of 90ms. The user can command a non-zero value to monitor a single parameter with an approximate update rate of 8ms. This command has a latency of up to 2 ADC conversions or approximately 16ms (external temperature conversions may have a latency of up to 3 ADC conversion or approximately 24ms). It is recommended the part remain in standard telemetry mode except for special cases where fast ADC updates of a single parameter is required. The part should be commanded to monitor the desired parameter for a limited period of time (less than 1 second) then set the command back to standard round robin mode. If this command is set to any value except standard round robin telemetry (0) all warnings and faults associated with telemetry other than the selected parameter are effectively disabled and voltage servoing is disabled. When round robin is reasserted, all warnings and faults and servo mode are re-enabled.

| COMMANDED VALUE | TELEMETRY COMMAND NAME | DESCRIPTION |
|-----------------|------------------------|--|
| 0x0F | | Reserved |
| 0x0E | | Reserved |
| 0x0D | | Reserved |
| 0x0C | READ_TEMPERATURE_1 | Channel 1 external temperature |
| 0x0B | | Reserved |
| 0x0A | READ_IOUT | Channel 1 measured output current |
| 0x09 | READ_VOUT | Channel 1 measured output voltage |
| 0x08 | READ_TEMPERATURE_1 | Channel 0 external temperature |
| 0x07 | | Reserved |
| 0x06 | READ_IOUT | Channel 0 measured output current |
| 0x05 | READ_VOUT | Channel 0 measured output voltage |
| 0x04 | READ_TEMPERATURE_2 | Internal junction temperature |
| 0x03 | READ_IIN | Measured input supply current |
| 0x02 | MFR_READ_ICHIP | Measured supply current of the LTC3889 |
| 0x01 | READ_VIN | Measured input supply voltage |
| 0x00 | | Standard ADC round robin telemetry |

If a reserved command value is entered, the telemetry will default to Internal IC Temperature and issue a CML fault. CML faults will continue to be issued by the LTC3889 until a valid command value is entered. The accuracy of the measured input supply voltage is only guaranteed if the MFR_ADC_CONTROL command is set to standard round robin telemetry. This write-only command has 1 data byte and is formatted in register format.

PMBus COMMAND DETAILS

MFR_VOUT_PEAK

The MFR_VOUT_PEAK command reports the highest voltage, in volts, reported by the READ_VOUT measurement.

This command is cleared using the MFR_CLEAR_PEAKE command.

This read-only command has two data bytes and is formatted in Linear_16u format.

MFR_VIN_PEAK

The MFR_VIN_PEAK command reports the highest voltage, in volts, reported by the READ_VIN measurement.

This command is cleared using the MFR_CLEAR_PEAKE command.

This read-only command has two data bytes and is formatted in Linear_5s_11s format.

MFR_TEMPERATURE_1_PEAK

The MFR_TEMPERATURE_1_PEAK command reports the highest temperature, in degrees Celsius, reported by the READ_TEMPERATURE_1 measurement.

This command is cleared using the MFR_CLEAR_PEAKE command.

This read-only command has two data bytes and is formatted in Linear_5s_11s format.

MFR_READ_IIN_PEAK

The MFR_READ_IIN_PEAK command reports the highest current, in Amperes, reported by the READ_IIN measurement.

This command is cleared using the MFR_CLEAR_PEAKE command.

This command has two data bytes and is formatted in Linear_5s_11s format.

MFR_READ_ICHIP

The MFR_READ_ICHIP command returns the measured input current, in Amperes, used by the LTC3889.

This command has two data bytes and is formatted in Linear_5s_11s format.

MFR_TEMPERATURE_2_PEAK

The MFR_TEMPERATURE_2_PEAK command reports the highest temperature, in degrees Celsius, reported by the READ_TEMPERATURE_2 measurement.

This command is cleared using the MFR_CLEAR_PEAKE command.

This read-only command has two data bytes and is formatted in Linear_5s_11s format.

PMBus COMMAND DETAILS

EEPROM MEMORY COMMANDS

Store/Restore

| COMMAND NAME | CMD CODE | DESCRIPTION | TYPE | PAGED | FORMAT | UNITS | EEPROM | DEFAULT VALUE |
|----------------------|----------|--|-----------|-------|--------|-------|--------|---------------|
| STORE_USER_ALL | 0x15 | Store user operating memory to EEPROM. | Send Byte | N | | | | NA |
| RESTORE_USER_ALL | 0x16 | Restore user operating memory from EEPROM. | Send Byte | N | | | | NA |
| MFR_COMPARE_USER_ALL | 0xF0 | Compares current command contents with EEPROM. | Send Byte | N | | | | NA |

STORE_USER_ALL

The STORE_USER_ALL command instructs the PMBus device to copy the non-volatile user contents of the Operating Memory to the matching locations in the non-volatile User EEPROM memory.

Executing this command if the die temperature exceeds 85°C or is below 0°C is not recommended and the data retention of 10 years cannot be guaranteed. If the die temperature exceeds 130°C, the STORE_USER_ALL command is disabled. The command is re-enabled when the IC temperature drops below 125°C.

Communication with the LTC3889 and programming of the EEPROM can be initiated when VDD33 is available and VIN is not applied. To enable the part in this state, using global address 0x5B write MFR_EE_UNLOCK to 0x2B followed by 0xC4. The LTC3889 will now communicate normally, and the project file can be updated. To write the updated project file to the EEPROM issue a STORE_USER_ALL command. When VIN is applied, a MFR_RESET must be issued to allow the PWM to be enabled and valid ADCs to be read.

This write-only command has no data bytes.

RESTORE_USER_ALL

The RESTORE_USER_ALL command instructs the PMBus device to copy the contents of the non-volatile User memory to the matching locations in the Operating Memory. The values in the Operating Memory are overwritten by the value retrieved from the User commands. The LTC3889 ensures both channels are off, loads the operating memory from the internal EEPROM, clears all faults, reads the resistor configuration pins, and then performs a soft-start of both PWM channels if applicable.

STORE_USER_ALL, MFR_COMPARE_USER_ALL and RESTORE_USER_ALL commands are disabled if the die exceeds 130°C and are not re-enabled until the die temperature drops below 125°C.

This write-only command has no data bytes.

PMBus COMMAND DETAILS

MFR_COMPARE_USER_ALL

The MFR_COMPARE_USER_ALL command instructs the PMBus device to compare current command contents with what is stored in non-volatile memory. If the compare operation detects differences, a CML fault will be generated.

This write-only command has no data bytes.

Fault Logging

| COMMAND NAME | CMD CODE | DESCRIPTION | TYPE | PAGED | DATA FORMAT | UNITS | EEPROM | DEFAULT VALUE |
|---------------------|----------|---|-----------|-------|-------------|-------|--------|---------------|
| MFR_FAULT_LOG | 0xEE | Fault log data bytes. | R Block | N | CF | | Y | NA |
| MFR_FAULT_LOG_STORE | 0xEA | Command a transfer of the fault log from RAM to EEPROM. | Send Byte | N | | | | NA |
| MFR_FAULT_LOG_CLEAR | 0xEC | Initialize the EEPROM block reserved for fault logging. | Send Byte | N | | | | NA |

Fault Log Operation

A conceptual diagram of the fault log is shown in Figure 49. The fault log provides black box capability for the LTC3889. During normal operation the contents of the status registers, the output voltage/current/temperature readings, the input voltage readings, as well as the peak values of these quantities, are stored in a continuously updated buffer in RAM. You can think of the operation as being similar to a strip chart recorder. When a fault occurs, the contents are written into EEPROM for non volatile storage. The EEPROM fault log is then locked. The part can be powered down with the fault log available for reading at a later time.

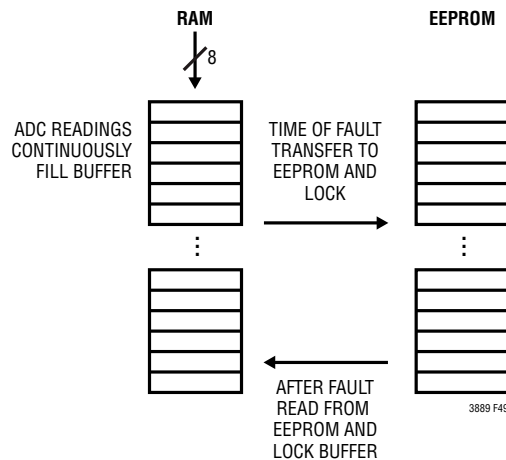

Figure 49. Fault Logging

PMBus COMMAND DETAILS

MFR_FAULT_LOG

The MFR_FAULT_LOG command allows the user to read the contents of the FAULT_LOG after the first fault occurrence since the last MFR_FAULT_LOG_CLEAR command was written. The contents of this command are stored in non-volatile memory, and are cleared by the MFR_FAULT_LOG_CLEAR command. The length and content of this command are listed in Table 13. If the user accesses the MFR_FAULT_LOG command and no fault log is present, the command will return a data length of 0. If a fault log is present, the MFR_FAULT_LOG will return a block of data 147 bytes long. The area available for the fault log in EEPROM is smaller than the area in RAM. When reading the fault log from RAM, all six events of cyclical data remain. However, when the fault log is read from EEPROM (after a reset), the last two events are lost. The read length of 147 bytes remains the same, but the fifth and sixth events are a repeat of the fourth event. If a fault occurs within the first second of applying power, some of the earlier pages in the fault log may not contain valid data.

NOTE: The approximate transfer time for this command is 3.4ms using a 400kHz clock.

This read-only command is in block format.

PMBus COMMAND DETAILS

MFR_FAULT_LOG_STORE

The MFR_FAULT_LOG_STORE command forces the fault log operation to be written to EEPROM just as if a fault event occurred. This command will set bit 3 of the STATUS_MFR_SPECIFIC fault if bit 7 “Enable Fault Logging” is set in the MFR_CONFIG_ALL_LTC3889 command.

If the die temperature exceeds 130°C, the MFR_FAULT_LOG_STORE command is disabled until the IC temperature drops below 125°C.

This write-only command has no data bytes.

Table 13. Fault Logging

This table outlines the format of the block data from a read block data of the MFR_FAULT_LOG command.

| Data Format Definitions | | | | LIN 11 = PMBus = Rev 1.1, Part 2, section 7.1 |
|----------------------------|---------|-------------|----------|--|
| | | | | LIN 16 = PMBus Rev 1.1, Part 2, section 8. Mantissa portion only |
| | | | | BYTE = 8 bits interpreted per definition of this command |
| DATA | BITS | DATA FORMAT | BYTE NUM | BLOCK READ COMMAND |
| Block Length | | BYTE | 147 | The MFR_FAULT_LOG command is a fixed length of 147 bytes The block length will be zero if a data log event has not been captured |
| HEADER INFORMATION | | | | |
| Fault Log Preface | [7:0] | ASC | 0 | Returns LTxx beginning at byte 0 if a partial or complete fault log exists. Word xx is a factory identifier that may vary part to part. |
| | [7:0] | | 1 | |
| | [15:8] | Reg | 2 | |
| | [7:0] | | 3 | |
| Fault Source | [7:0] | Reg | 4 | Refer to Table 13a. |
| MFR_REAL_TIME | [7:0] | Reg | 5 | 48 bit share-clock counter value when fault occurred (200µs resolution). |
| | [15:8] | | 6 | |
| | [23:16] | | 7 | |
| | [31:24] | | 8 | |
| | [39:32] | | 9 | |
| | [47:40] | | 10 | |
| MFR_VOUT_PEAK (PAGE 0) | [15:8] | L16 | 11 | Peak READ_VOUT on Channel 0 since last power-on or CLEAR_PEAKS command. |
| | [7:0] | | 12 | |
| MFR_VOUT_PEAK (PAGE 1) | [15:8] | L16 | 13 | Peak READ_VOUT on Channel 1 since last power-on or CLEAR_PEAKS command. |
| | [7:0] | | 14 | |
| MFR_IOUT_PEAK (PAGE 0) | [15:8] | L11 | 15 | Peak READ_IOUT on Channel 0 since last power-on or CLEAR_PEAKS command. |
| | [7:0] | | 16 | |
| MFR_IOUT_PEAK (PAGE 1) | [15:8] | L11 | 17 | Peak READ_IOUT on Channel 1 since last power-on or CLEAR_PEAKS command. |
| | [7:0] | | 18 | |
| MFR_VIN_PEAK | [15:8] | L11 | 19 | Peak READ_VIN since last power-on or CLEAR_PEAKS command. |
| | [7:0] | | 20 | |
| READ_TEMPERATURE1 (PAGE 0) | [15:8] | L11 | 21 | External temperature sensor 0 during last event. |

PMBus COMMAND DETAILS

| | | | | |
|----------------------------|--------|-----|----|---|
| | [7:0] | | 22 | |
| READ_TEMPERATURE1 (PAGE 1) | [15:8] | L11 | 23 | External temperature sensor 1 during last event. |
| | [7:0] | | 24 | |
| READ_TEMPERATURE2 | [15:8] | L11 | 25 | LTC3889 die temperature sensor during last event. |
| | [7:0] | | 26 | |

CYCLICAL DATA

| | | | | |
|---|---|--|--|--|
| EVENT n (Data at Which Fault Occurred; Most Recent Data) | Event “n” represents one complete cycle of ADC reads through the MUX at time of fault. Example: If the fault occurs when the ADC is processing step 15, it will continue to take readings through step 25 and then store the header and all 6 event pages to EEPROM | | | |
|---|---|--|--|--|

| | | | | |
|------------------------------|--------|--------|----|--|
| READ_VOUT (PAGE 0) | [15:8] | LIN 16 | 27 | |
| | [7:0] | LIN 16 | 28 | |
| READ_VOUT (PAGE 1) | [15:8] | LIN 16 | 29 | |
| | [7:0] | LIN 16 | 30 | |
| READ_IOUT (PAGE 0) | [15:8] | LIN 11 | 31 | |
| | [7:0] | LIN 11 | 32 | |
| READ_IOUT (PAGE 1) | [15:8] | LIN 11 | 33 | |
| | [7:0] | LIN 11 | 34 | |
| READ_VIN | [15:8] | LIN 11 | 35 | |
| | [7:0] | LIN 11 | 36 | |
| READ_IIN | [15:8] | LIN 11 | 37 | |
| | [7:0] | LIN 11 | 38 | |
| STATUS_VOUT (PAGE 0) | | BYTE | 39 | |
| STATUS_VOUT (PAGE 1) | | BYTE | 40 | |
| STATUS_WORD (PAGE 0) | [15:8] | WORD | 41 | |
| | [7:0] | WORD | 42 | |
| STATUS_WORD (PAGE 1) | [15:8] | WORD | 43 | |
| | [7:0] | WORD | 44 | |
| STATUS_MFR_SPECIFIC (PAGE 0) | | BYTE | 45 | |
| STATUS_MFR_SPECIFIC (PAGE 1) | | BYTE | 46 | |

EVENT n-1

(data measured before fault was detected)

| | | | | |
|--------------------|--------|--------|----|--|
| READ_VOUT (PAGE 0) | [15:8] | LIN 16 | 47 | |
| | [7:0] | LIN 16 | 48 | |
| READ_VOUT (PAGE 1) | [15:8] | LIN 16 | 49 | |
| | [7:0] | LIN 16 | 50 | |
| READ_IOUT (PAGE 0) | [15:8] | LIN 11 | 51 | |
| | [7:0] | LIN 11 | 52 | |
| READ_IOUT (PAGE 1) | [15:8] | LIN 11 | 53 | |
| | [7:0] | LIN 11 | 54 | |
| READ_VIN | [15:8] | LIN 11 | 55 | |
| | [7:0] | LIN 11 | 56 | |
| READ_IIN | [15:8] | LIN 11 | 57 | |
| | [7:0] | LIN 11 | 58 | |

PMBus COMMAND DETAILS

| | | | | |
|-------------------------------|--------|--------|-----|--|
| STATUS_VOUT (PAGE 0) | | BYTE | 59 | |
| STATUS_VOUT (PAGE 1) | | BYTE | 60 | |
| STATUS_WORD (PAGE 0) | [15:8] | WORD | 61 | |
| | [7:0] | WORD | 62 | |
| STATUS_WORD (PAGE 1) | [15:8] | WORD | 63 | |
| | [7:0] | WORD | 64 | |
| STATUS_MFR_SPECIFIC (PAGE 0) | | BYTE | 65 | |
| STATUS_MFR_SPECIFIC (PAGE 1) | | BYTE | 66 | |
| * | | | | |
| * | | | | |
| * | | | | |
| EVENT n-5 | | | | |
| (Oldest Recorded Data) | | | | |
| READ_VOUT (PAGE 0) | [15:8] | LIN 16 | 127 | |
| | [7:0] | LIN 16 | 128 | |
| READ_VOUT (PAGE 1) | [15:8] | LIN 16 | 129 | |
| | [7:0] | LIN 16 | 130 | |
| READ_IOUT (PAGE 0) | [15:8] | LIN 11 | 131 | |
| | [7:0] | LIN 11 | 132 | |
| READ_IOUT (PAGE 1) | [15:8] | LIN 11 | 133 | |
| | [7:0] | LIN 11 | 134 | |
| READ_VIN | [15:8] | LIN 11 | 135 | |
| | [7:0] | LIN 11 | 136 | |
| READ_IIN | [15:8] | LIN 11 | 137 | |
| | [7:0] | LIN 11 | 138 | |
| STATUS_VOUT (PAGE 0) | | BYTE | 139 | |
| STATUS_VOUT (PAGE 1) | | BYTE | 140 | |
| STATUS_WORD (PAGE 0) | [15:8] | WORD | 141 | |
| | [7:0] | WORD | 142 | |
| STATUS_WORD (PAGE 1) | [15:8] | WORD | 143 | |
| | [7:0] | WORD | 144 | |
| STATUS_MFR_SPECIFIC (PAGE 0) | | BYTE | 145 | |
| STATUS_MFR_SPECIFIC (PAGE 1) | | BYTE | 146 | |

PMBus COMMAND DETAILS

Table 13a. Explanation of Position_Fault Values

| POSITION_FAULT VALUE | SOURCE OF FAULT LOG |
|----------------------|----------------------------|
| 0xFF | MFR_FAULT_LOG_STORE |
| 0x00 | TON_MAX_FAULT Channel 0 |
| 0x01 | VOUT_OV_FAULT Channel 0 |
| 0x02 | VOUT_UV_FAULT Channel 0 |
| 0x03 | IOUT_OC_FAULT Channel 0 |
| 0x05 | TEMP_OT_FAULT Channel 0 |
| 0x06 | TEMP_UT_FAULT Channel 0 |
| 0x07 | VIN_OV_FAULT |
| 0x0A | MFR_TEMPERATURE_2_OT_FAULT |
| 0x10 | TON_MAX_FAULT Channel 1 |
| 0x11 | VOUT_OV_FAULT Channel 1 |
| 0x12 | VOUT_UV_FAULT Channel 1 |
| 0x13 | IOUT_OC_FAULT Channel 1 |
| 0x15 | OT_FAULT Channel 1 |
| 0x16 | UT_FAULT Channel 1 |
| 0x17 | VIN_OV_FAULT |
| 0x1A | MFR_TEMPERATURE_2_OT_FAULT |

MFR_FAULT_LOG_CLEAR

The MFR_FAULT_LOG_CLEAR command will erase the fault log file stored values. It will also clear bit 3 in the STATUS_MFR_SPECIFIC command. After a clear is issued, the status can take up to 8ms to clear.

This write-only command is send bytes.

Block Memory Write/Read

| COMMAND NAME | CMD CODE | DESCRIPTION | TYPE | PAGED | DATA FORMAT | UNITS | EEPROM | DEFAULT VALUE |
|---------------|----------|---|----------|-------|-------------|-------|--------|---------------|
| MFR_EE_UNLOCK | 0xBD | Unlock user EEPROM for access by MFR_EE_ERASE and MFR_EE_DATA commands. | R/W Byte | N | Reg | | | NA |
| MFR_EE_ERASE | 0xBE | Initialize user EEPROM for bulk programming by MFR_EE_DATA. | R/W Byte | N | Reg | | | NA |
| MFR_EE_DATA | 0xBF | Data transferred to and from EEPROM using sequential PMBus word reads or writes. Supports bulk programming. | R/W Word | N | Reg | | | NA |

All the EEPROM commands are disabled if the die temperature exceeds 130°C. EEPROM commands are re-enabled when the die temperature drops below 125°C.

MFR_EE_xxxx

The MFR_EE_xxxx commands facilitate bulk programming of the LTC3889 internal EEPROM. Contact the factory for details.

PACKAGE DESCRIPTION

UKG Package
Variation: UKG52(46)
52-Lead Plastic QFN (7mm × 8mm)
 (Reference LTC DWG # 05-08-1947 Rev 0)

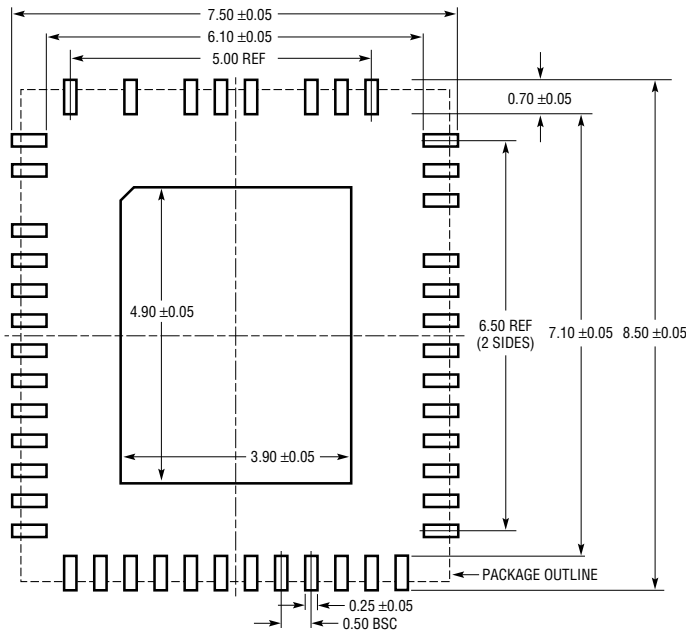

RECOMMENDED SOLDER PAD PITCH AND DIMENSIONS
 APPLY SOLDER MASK TO AREAS THAT ARE NOT SOLDERED

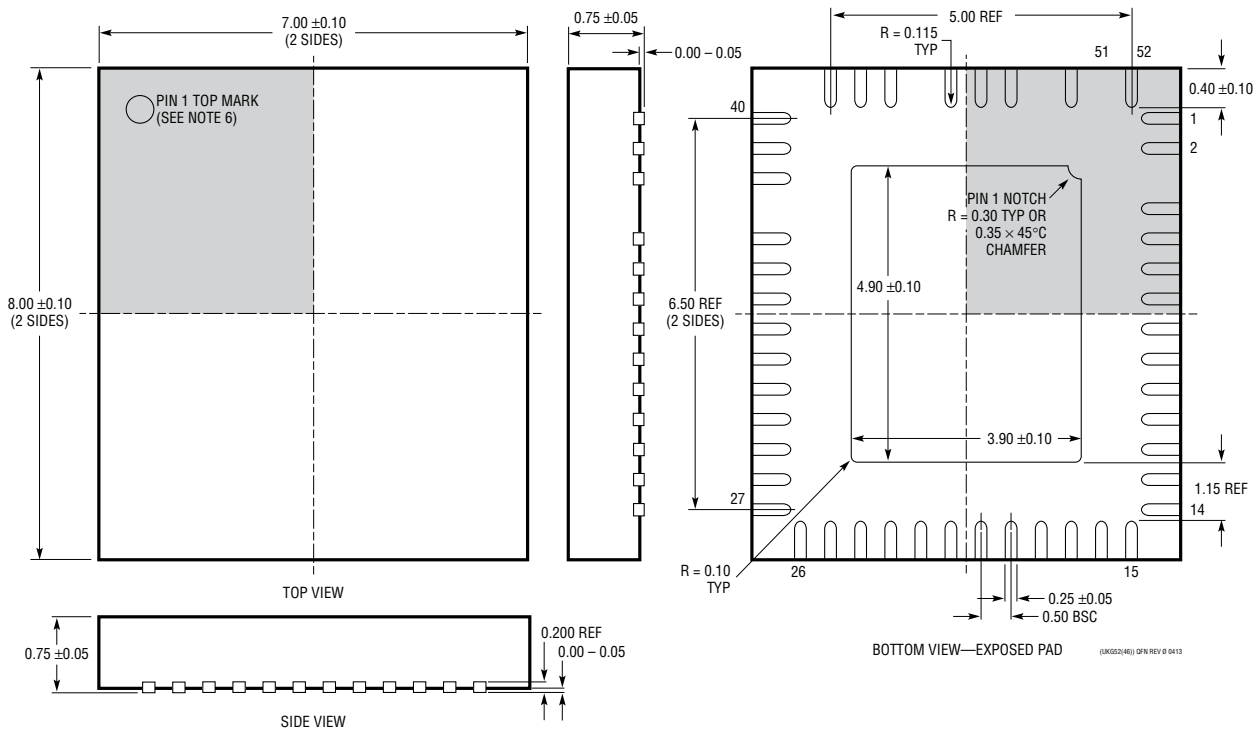

- NOTE:
1. DRAWING IS NOT A JEDEC PACKAGE OUTLINE
 2. DRAWING NOT TO SCALE
 3. ALL DIMENSIONS ARE IN MILLIMETERS
 4. DIMENSIONS OF EXPOSED PAD ON BOTTOM OF PACKAGE DO NOT INCLUDE MOLD FLASH. MOLD FLASH, IF PRESENT, SHALL NOT EXCEED 0.20mm ON ANY SIDE, IF PRESENT
 5. EXPOSED PAD SHALL BE SOLDER PLATED
 6. SHADED AREA IS ONLY A REFERENCE FOR PIN 1 LOCATION ON THE TOP AND BOTTOM OF PACKAGE

TYPICAL APPLICATION

High Efficiency 250kHz 2-Phase 24V Step-Down Converter with Sense Resistors

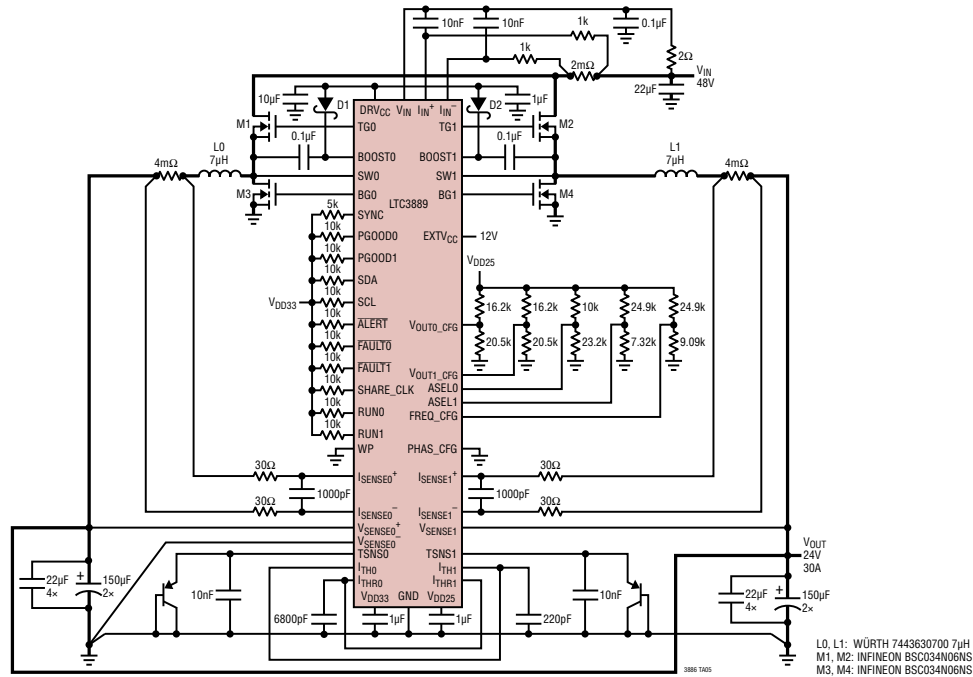

RELATED PARTS

| PART NUMBER | DESCRIPTION | COMMENTS |
|-----------------------|--|---|
| LTM4676A | Dual 13A or Single 26A Step-Down DC/DC µModule Regulator with Digital Power System Management | V_{IN} Up to 26.5V; $0.5V \leq V_{OUT} (\pm 0.5\%) \leq 5.4V$, $\pm 2\%$ I_{OUT} Accuracy, Fault Logging, I ² C/PMBus Interface, 16mm × 16mm × 5mm, BGA Package |
| LTM4675 | Dual 9A or Single 18A Step-Down DC/DC µModule Regulator with Digital Power System Management | $4.5V \leq V_{IN} \leq 17V$; $0.5V \leq V_{OUT} \leq 5.5V$, $\pm 0.5\%$ V_{OUT} Accuracy I ² C/PMBus Interface, 11.9mm × 16mm × 3.51mm, BGA Package |
| LTM4677 | Dual 18A or Single 36A µModule Regulator with Digital Power System Management | $4.5V \leq V_{IN} \leq 16V$; $0.5V \leq V_{OUT} (\pm 0.5\%) \leq 1.8V$, I ² C/PMBus Interface, 16mm × 16mm × 5.01mm, BGA Package |
| LTC3870/ LTC3870-1 | 60V Dual Output Multiphase Step-Down Slave Controller for Current Mode Control Applications with Digital Power System Management | V_{IN} Up to 60V, $0.5V \leq V_{OUT} \leq 14V$, Very High Output Current Applications with Accurate Current Share Between Phases Supporting LTC3880/LTC3880-1, LTC3883/LTC3883-1, LTC3886, LTC3887/LTC3887-1 |
| LTC3884/ LTC3884-1 | Dual Output Multiphase Step-Down Controller with Sub MilliOhm DCR Sensing Current Mode Control and Digital Power System Management | $4.5V \leq V_{IN} \leq 38V$, $0.5V \leq V_{OUT} (\pm 0.5\%) \leq 5.5V$, I ² C/PMBus Interface, Programmable Analog Loop Compensation, Input Current Sense |
| LTC3887/ LTC3887-1 | Dual Output Multiphase Step-Down DC/DC Controller with Digital Power System Management | V_{IN} Up to 24V, $0.5V \leq V_{OUT0,1} \leq 5.5V$, Analog Control Loop, I ² C/PMBus Interface with EEPROM and 16-Bit ADC |
| LTC3882/ LTC3882-1 | Dual Output Multiphase Step-Down DC/DC Voltage Mode Controller with Digital Power System Management | V_{IN} Up to 38V, $0.5V \leq V_{OUT1,2} \leq 5.25V$, $\pm 0.5\%$ V_{OUT} Accuracy I ² C/PMBus Interface with EEPROM and 16-Bit ADC |
| LTC3886 | 60V Dual Output Step-Down Controller with PSM | $4.5V < V_{IN} < 60V$, $0.5V \leq V_{OUT} (\pm 0.5\%) \leq 13.8V$, Input Current Sense, I ² C/PMBus Interface with EEPROM and 16-Bit ADC |
| LTC2977 | 8-Channel PMBus Power System Manager Featuring Accurate Output Voltage Measurement | Fault Logging to Internal EEPROM Monitors Eight Output Voltages, Input Voltage and Die Temperature |
| LTC3815 | 6A Monolithic Synchronous DC/DC Step-Down Converter with Digital Power System Management | $2.25V \leq V_{IN} \leq 5.5V$, $0.4V \leq V_{OUT} \leq 0.72V_{IN}$, Programmable V_{OUT} Range $\pm 25\%$ with 0.1% Resolution, Up to 3MHz Operation with 13-Bit ADC |
| LTC3874 | Multiphase Step-Down Synchronous Slave Controller with Sub MilliOhm DCR Sensing | $4.5V \leq V_{IN} \leq 38V$, V_{OUT} up to 5.5V, Very High Output Current, Accurate Current Sharing, Current Mode Applications |

Rev. 0