

## ESD224 Low Clamping 4-Channel ESD Protection Device for HDMI Interface

### 1 Features

- IEC 61000-4-2 Level 4 ESD Protection
  - ±12-kV Contact Discharge
  - ±15-kV Air Gap Discharge
- IEC 61000-4-4 EFT Protection
  - 80 A (5/50 ns)
- IEC 61000-4-5 Surge Protection
  - 2 A (8/20 μs)
- IO Capacitance:
  - 0.5 pF (Typical)
- [HDMI 2.0 Compliant](#)
- Ultra-Low Leakage Current: 0.1 nA (Typical)
- Ultra-Low ESD Clamping Voltage: 8 V at 16-A TLP (System Side)
- Supports High Speed Interfaces up to 6 Gbps
- Industrial Temperature Range: –40°C to +125°C
- Industry Standard DQA Package

### 2 Applications

- End Equipment
  - Set-Top Boxes
  - TV and Monitors
  - Laptops and Desktops
  - DVD, Blue-ray, Multimedia Players
- Interfaces
  - HDMI 2.0/1.4
  - Ethernet 10/100/1000 Mbps
  - USB 3.0

### 3 Description

The ESD224 is a bidirectional TVS ESD protection diode array for high speed applications such as USB 3.0 and HDMI 2.0. The ESD224 is rated to dissipate ESD strikes at the maximum level specified in the IEC 61000-4-2 international standard (Level 4). The ESD224 employs on-chip differentially matched series elements to enhance down-stream ESD clamping performance while maintaining the signal compliance for high speed interfaces. The ultra-low clamping performance and high differential bandwidth provided by the ESD224 on-chip ESD protection network enables the device to be HDMI 2.0 compliant while providing robust protection to downstream HDMI devices.

The ESD224 is offered in the industry standard USON-10 (DQA) package. The package features 0.5-mm pin pitch easing implementation and reducing design time.

#### Device Information<sup>(1)</sup>

PART NUMBER	PACKAGE	BODY SIZE (NOM)
ESD224	USON (10)	2.50 mm x 1.00 mm

(1) For all available packages, see the orderable addendum at the end of the data sheet.

#### Typical Application Schematic

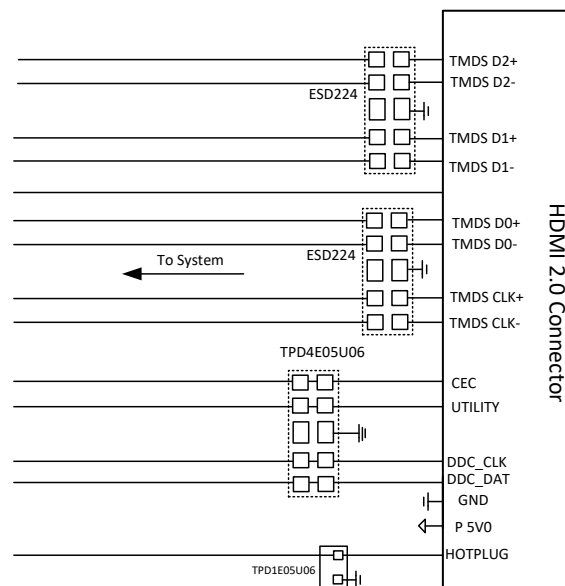

Copyright © 2018, Texas Instruments Incorporated



## Table of Contents

<b>1 Features</b> .....	<b>1</b>	8.2 Functional Block Diagram .....	<b>9</b>
<b>2 Applications</b> .....	<b>1</b>	8.3 Feature Description .....	<b>9</b>
<b>3 Description</b> .....	<b>1</b>	8.4 Device Functional Modes .....	<b>10</b>
<b>4 Revision History</b> .....	<b>2</b>	<b>9 Application and Implementation</b> .....	<b>11</b>
<b>5 Pin Configuration and Functions</b> .....	<b>3</b>	9.1 Application Information .....	<b>11</b>
<b>6 Specifications</b> .....	<b>4</b>	9.2 Typical Application .....	<b>11</b>
6.1 Absolute Maximum Ratings .....	<b>4</b>	<b>10 Power Supply Recommendations</b> .....	<b>13</b>
6.2 ESD Ratings - JEDEC Specifications .....	<b>4</b>	<b>11 Layout</b> .....	<b>13</b>
6.3 ESD Ratings - IEC Specifications .....	<b>4</b>	11.1 Layout Guidelines .....	<b>13</b>
6.4 Recommended Operating Conditions .....	<b>4</b>	11.2 Layout Examples .....	<b>14</b>
6.5 Thermal Information .....	<b>4</b>	<b>12 Device and Documentation Support</b> .....	<b>15</b>
6.6 Electrical Characteristics .....	<b>5</b>	12.1 Documentation Support .....	<b>15</b>
6.7 Typical Characteristics .....	<b>6</b>	12.2 Receiving Notification of Documentation Updates .....	<b>15</b>
<b>7 Parameter Measurement Setup</b> .....	<b>8</b>	12.3 Community Resources .....	<b>15</b>
7.1 IEC 61000-4-2 System Level ESD Test Setup with HDMI Driver for Clamping Voltage Measurement .....	<b>8</b>	12.4 Trademarks .....	<b>15</b>
<b>8 Detailed Description</b> .....	<b>9</b>	12.5 Electrostatic Discharge Caution .....	<b>15</b>
8.1 Overview .....	<b>9</b>	12.6 Glossary .....	<b>15</b>
		<b>13 Mechanical, Packaging, and Orderable Information</b> .....	<b>15</b>

## 4 Revision History

<b>Changes from Original (February 2018) to Revision A</b>	<b>Page</b>
• Changed product status from Advance Information to Production Data .....	<b>1</b>

## 5 Pin Configuration and Functions

**DQA Package  
10-Pin USON  
Top View**

Top View

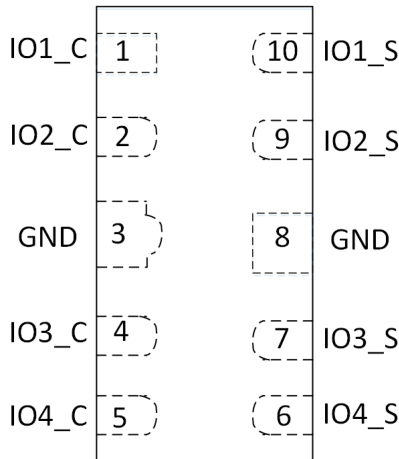

USON-10 2.5 mm x 1.0 mm, 0.5 mm pitch

### Pin Functions

PIN		TYPE	DESCRIPTION
NAME	NO.		
GND	3	Ground	Ground. Connect to ground. These pins are shorted internally.
GND	8		
IO1_C	1	Connector Side I/O	ESD protected channel to be connected to the connector
IO2_C	2		
IO3_C	4		
IO4_C	5		
IO4_S	6	System Side I/O Pin corresponding to IO4_C	To be connected to the system side
IO3_S	7	System Side I/O Pin corresponding to IO3_C	
IO2_S	9	System Side I/O Pin corresponding to IO2_C	
IO1_S	10	System Side I/O Pin corresponding to IO1_C	

## 6 Specifications

### 6.1 Absolute Maximum Ratings

over operating free-air temperature range (unless otherwise noted)<sup>(1)</sup>

		MIN	MAX	UNIT
Electrical Fast Transient	IEC 61000-4-4 Peak Current at 25°C		80	A
Peak Pulse	IEC 61000-4-5 Surge ( $t_p$ 8/20 $\mu$ s) Peak Power at 25°C		17	W
	IEC 61000-4-5 Surge ( $t_p$ 8/20 $\mu$ s) Peak Current at 25°C		2	A
$T_A$	Operating free-air temperature	-40	125	°C
$T_{stg}$	Storage temperature	-65	155	°C

(1) Stresses beyond those listed under *Absolute Maximum Rating* may cause permanent damage to the device. These are stress ratings only, which do not imply functional operation of the device at these or any other conditions beyond those indicated under *Recommended Operating Condition*. Exposure to absolute-maximum-rated conditions for extended periods may affect device reliability.

### 6.2 ESD Ratings -JEDEC Specifications

		VALUE	UNIT
$V_{(ESD)}$	Electrostatic discharge	Human body model (HBM), per ANSI/ESDA/JEDEC JS-001, all pins <sup>(1)</sup>	±2500
		Charged device model (CDM), per JEDEC specification JESD22-C101, all pins <sup>(2)</sup>	±1000

(1) JEDEC document JEP155 states that 500-V HBM allows safe manufacturing with a standard ESD control process.

(2) JEDEC document JEP157 states that 250-V CDM allows safe manufacturing with a standard ESD control process.

### 6.3 ESD Ratings - IEC Specifications

		VALUE	UNIT
$V_{(ESD)}$	Electrostatic discharge	IEC 61000-4-2 Contact Discharge, all pins	±12000
		IEC 61000-4-2 Air Discharge, all pins	±15000

### 6.4 Recommended Operating Conditions

over operating free-air temperature range (unless otherwise noted)

		MIN	NOM	MAX	UNIT
$V_{IN}$	Input voltage	-3.6		3.6	V
$T_A$	Operating Free Air Temperature	-40		125	°C

### 6.5 Thermal Information

THERMAL METRIC <sup>(1)</sup>		ESD224	UNIT
		DQA (USON)	
		10 PINS	
$R_{\theta JA}$	Junction-to-ambient thermal resistance	173.4	°C/W
$R_{\theta JC(top)}$	Junction-to-case (top) thermal resistance	109.6	°C/W
$R_{\theta JB}$	Junction-to-board thermal resistance	77.6	°C/W
$\Psi_{JT}$	Junction-to-top characterization parameter	14.3	°C/W
$\Psi_{JB}$	Junction-to-board characterization parameter	77.3	°C/W
$R_{\theta JC(bot)}$	Junction-to-case (bottom) thermal resistance	N/A	°C/W

(1) For more information about traditional and new thermal metrics, see the [Semiconductor and IC Package Thermal Metrics](#) application report.

## 6.6 Electrical Characteristics

 At  $T_A = 25^\circ\text{C}$  unless otherwise noted

PARAMETER		TEST CONDITIONS	MIN	TYP	MAX	UNIT
$V_{RWM}$	Reverse stand-off voltage	$I_{IO} < 10 \text{ nA}$ , across operating temperature range	-3.6		3.6	V
$V_{BRF}$	Breakdown voltage, Pin 1, 2, 4, 5 to 3 (GND) <sup>(1)</sup>	$I_{IO} = 1 \text{ mA}$	5		7.9	V
$V_{BRR}$	Reverse breakdown voltage, pin 1, 2, 4, 5 to 3 (GND) <sup>(1)</sup>	$I_{IO} = -1 \text{ mA}$	-7.9		-5	V
$V_{HOLD}$	Holding voltage, pin1, 2, 4, 5 to 3 (GND) and 3 (GND) to pin 1, 2, 4, 5 <sup>(2)</sup>	$I_{IO} = 1 \text{ mA}$		6.3		V
$V_{HOLD-NEG}$	Breakdown voltage, pin1, 2, 4, 5 to 3 (GND) <sup>(2)</sup>	$I_{IO} = -1 \text{ mA}$		-6.3		V
$V_{CLAMP}$	TLP Clamping voltage (Intrinsic)	IPP = 1 A, pin 1, 2, 4, 5 to 3 or 8(GND), GND to pin 1, 2, 4, 5		7		V
		IPP = 5 A, pin 1, 2, 4, 5 to 3 or 8(GND), GND to pin 1, 2, 4, 5		9		V
		IPP = 16 A, pin 1, 2, 4, 5 to 3 or 8(GND), GND to pin 1, 2, 4, 5		14		V
$V_{CLAMP-IEC-SYS}$	IEC 61000-4-2 30 ns Clamping voltage (system side) assuming system draws at least 3 A of current at 8 V. <a href="#">See measurement setup.</a>	8-kV Contact discharge on pin 1, 2, 4, 5 with pin3 grounded. Voltage waveform measured at pin 6, 7, 9, 10 with respect to GND		8		V
		-8-kV Contact discharge on pin 1, 2, 4, 5 with pin3 grounded. Voltage waveform measured at pin 6, 7, 9, 10 with respect to GND		-5		V
$R_{DYN}$	Dynamic resistance	Pin 1, 2, 4, 5 to GND, 100 ns TLP		0.5		$\Omega$
		GND to Pin 1, 2, 4, 5, 100 ns TLP		0.5		
$C_{LINE}$	Line capacitance, any IO to GND	$V_{IO} = 0 \text{ V}$ , $V_{p-p} = 30 \text{ mV}$ , $f = 1 \text{ MHz}$		0.5	0.6	pF
$\Delta C_{LINE}$	Variation of line capacitance	$C_{LINE1} - C_{LINE2}$ , $V_{IO} = 0 \text{ V}$ , $V_{p-p} = 30 \text{ mV}$ , $f = 1 \text{ MHz}$		0.02	0.07	pF
$C_{CROSS}$	Line-to-line capacitance between one differential pair to another differential pair	$V_{IO} = 0 \text{ V}$ , $V_{rms} = 30 \text{ mV}$ , $f = 1 \text{ MHz}$		0.28		pF
$S_{21DC}$	DC Insertion Loss	DC insertion loss at Ch1, Ch2, Ch3, Ch4		0.3		dB
$I_{leakage}$	Leakage Current	$V_{IO} = \pm 3.6 \text{ V}$ , Pin 1,2,4,5 to Pin 3		0.1	10	nA

(1)  $V_{BRF}$  and  $V_{BRR}$  are defined as the voltage obtained at 1 mA when sweeping the voltage up, before the device latches into the snapback state

(2)  $V_{HOLD}$  is defined as the voltage when 1 mA is applied, after the device has successfully latched into the snapback state.

### 6.7 Typical Characteristics

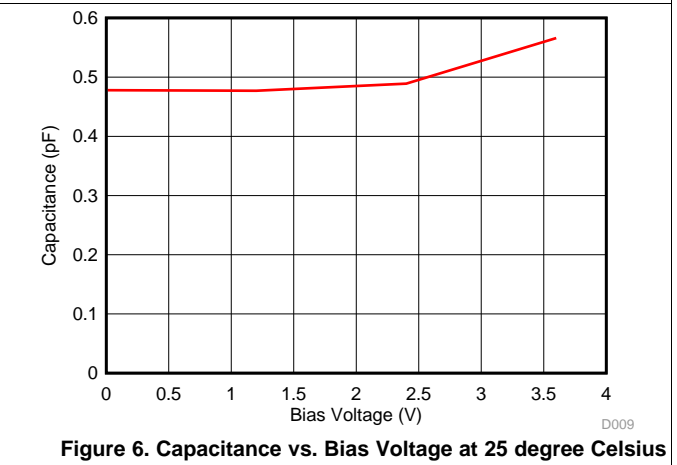
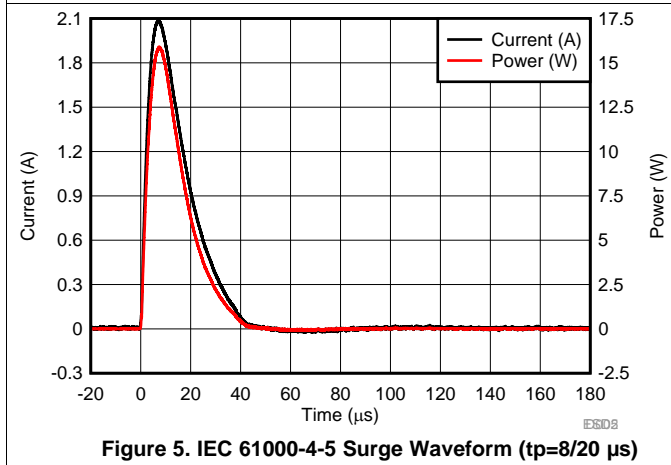
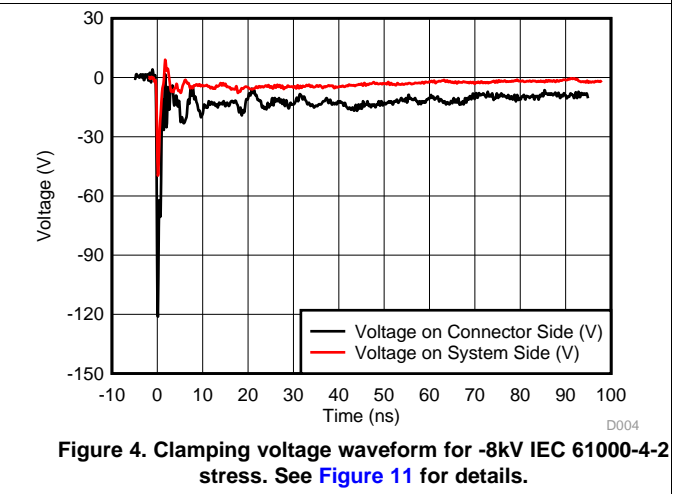
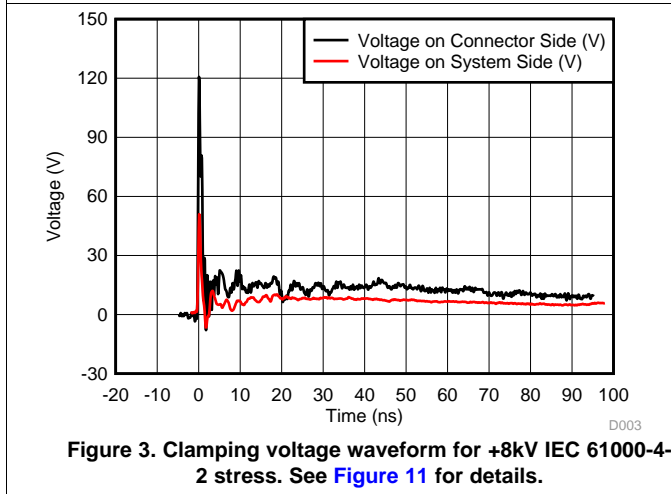
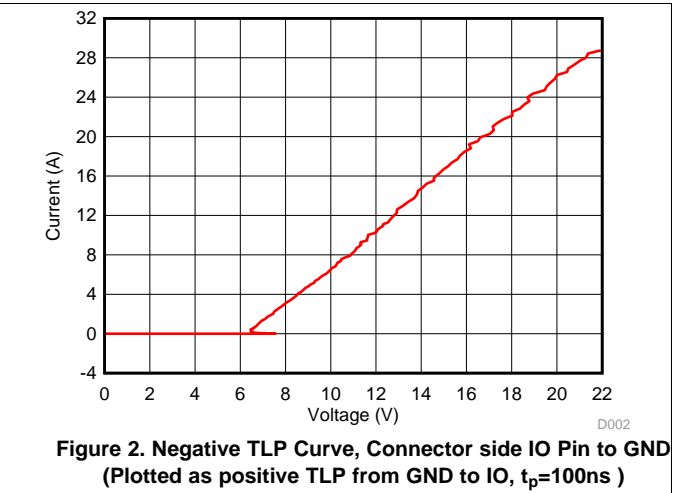
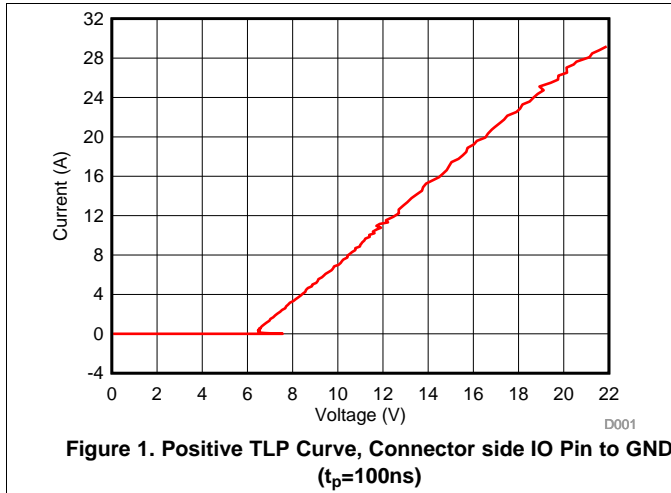

**Typical Characteristics (continued)**

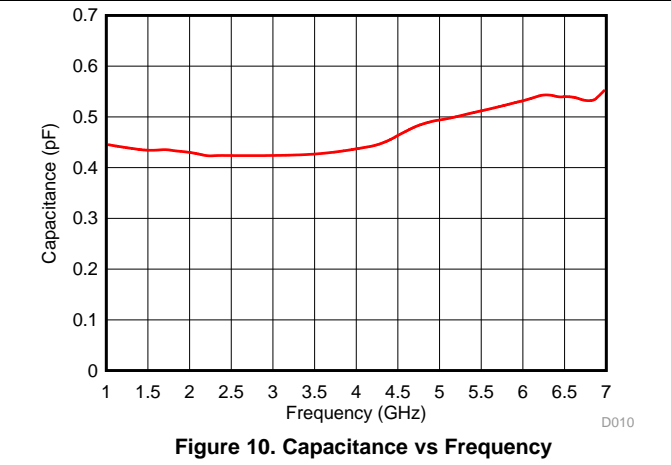
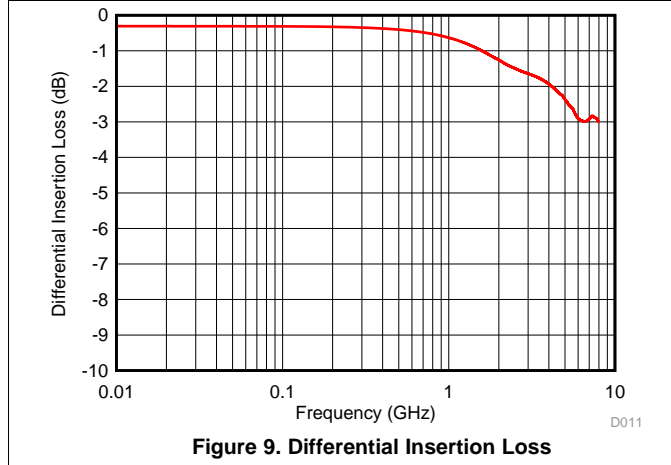
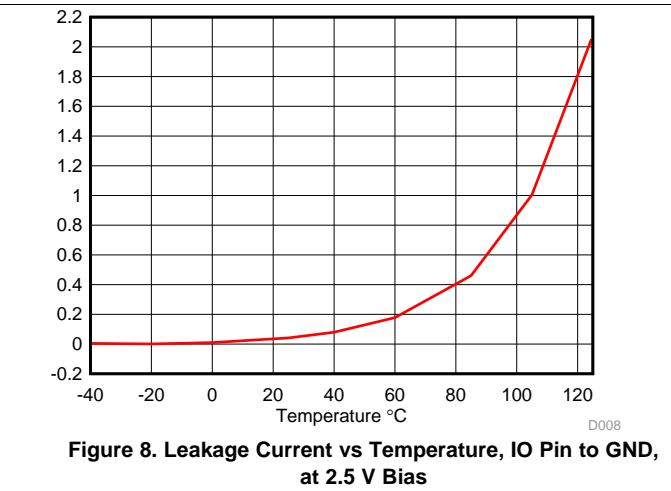
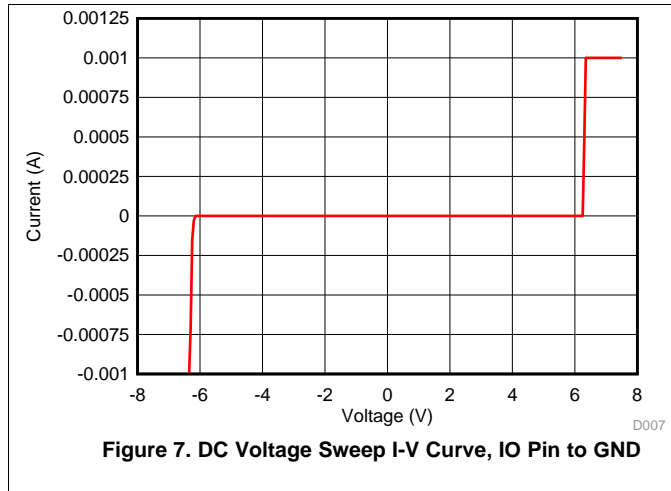

## 7 Parameter Measurement Setup

### 7.1 IEC 61000-4-2 System Level ESD Test Setup with HDMI Driver for Clamping Voltage Measurement

Figure 11 shows the setup used to perform System Level ESD test to evaluate the clamping performance of ESD224 in real-world applications where the device is protecting a downstream HDMI driver System-on-Chip. IEC 61000-4-2 8kV Contact stress was applied at the connector pin and the voltage waveform on the system-side pin was captured to look at the clamping voltage presented by ESD224 to the downstream HDMI driver.

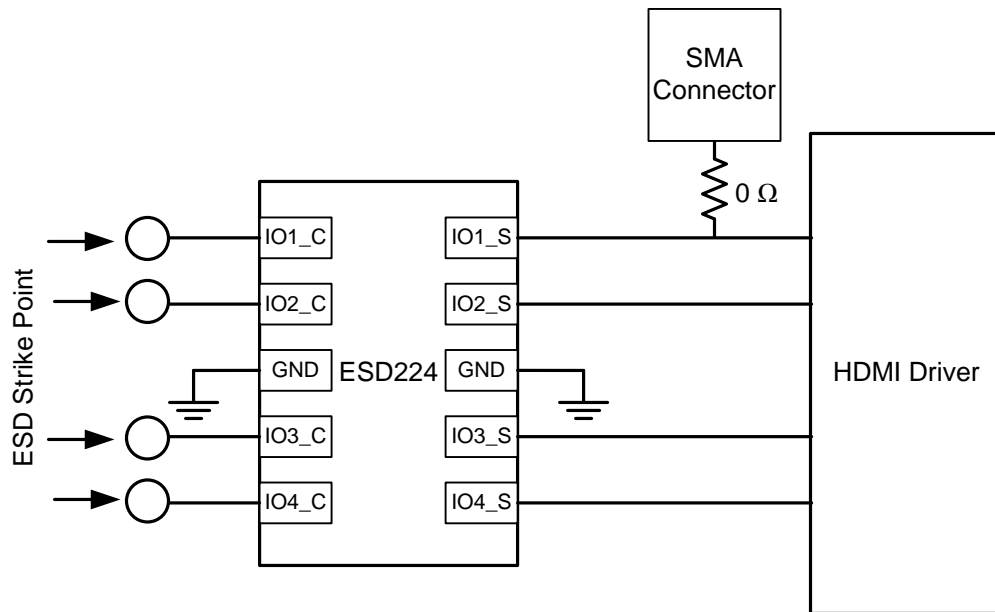

Figure 11. System Level IEC 61000-4-2 ESD Test Setup with ESD224 protecting an HDMI driver chip

## 8 Detailed Description

### 8.1 Overview

The ESD224 is a bidirectional ESD Protection Diode with ultra-low capacitance. This device can dissipate ESD strikes above the maximum level specified by the IEC 61000-4-2 International Standard. The ultra-low capacitance makes this device ideal for protecting any super high-speed signal pins.

### 8.2 Functional Block Diagram

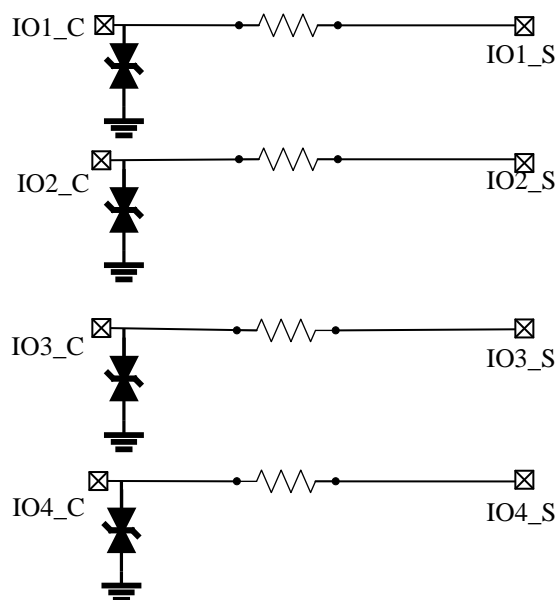

Copyright © 2018, Texas Instruments Incorporated

### 8.3 Feature Description

#### 8.3.1 IEC 61000-4-2 ESD Protection

The I/O pins can withstand ESD events up to  $\pm 12$ -kV contact and  $\pm 15$ -kV air gap. The ESD-surge clamp diverts the current to ground.

#### 8.3.2 IEC 61000-4-4 EFT Protection

The I/O pins can withstand an electrical fast transient burst of up to 80 A (5/50 ns waveform, 4 kV with 50- $\Omega$  impedance). The ESD-surge clamp diverts the current to ground.

#### 8.3.3 IEC 61000-4-5 Surge Protection

The I/O pins can withstand surge events up to 2 A and 17 W (8/20  $\mu$ s waveform). The ESD-surge clamp diverts this current to ground.

#### 8.3.4 IO Capacitance

The capacitance between each I/O pin to ground is 0.5 pF (typical). This device supports data rates up to 6 Gbps.

#### 8.3.5 DC Breakdown Voltage

The DC breakdown voltage of each I/O pin is a minimum of  $\pm 5.5$  V. This ensures that sensitive equipment is protected from surges above the reverse standoff voltage of  $\pm 3.6$  V.

## Feature Description (continued)

### 8.3.6 Ultra Low Leakage Current

The I/O pins feature an ultra-low leakage current of 10 nA (maximum) with a bias of  $\pm 2.5$  V.

### 8.3.7 Low ESD Clamping Voltage

The I/O pins feature an ESD clamp that is capable of clamping the voltage to 8 V ( $I_{PP} = 16$  A TLP) on the system side pins when the system draws at least 3 A.

### 8.3.8 Supports High Speed Interfaces

This device is capable of supporting high speed interfaces up to 6 Gbps, because of the extremely low IO capacitance.

### 8.3.9 Industrial Temperature Range

This device features an industrial operating range of  $-40^{\circ}\text{C}$  to  $+125^{\circ}\text{C}$ .

## 8.4 Device Functional Modes

The ESD224 is a passive integrated circuit that triggers when voltages are above  $V_{BRF}$  or below  $V_{BRR}$ . During ESD events, voltages as high as  $\pm 15$  kV (air) can be directed to ground via the internal diode network. When the voltages on the protected line fall below the trigger levels of ESD224 (usually within 100s of nano-seconds) the device reverts to passive.

## 9 Application and Implementation

### NOTE

Information in the following applications sections is not part of the TI component specification, and TI does not warrant its accuracy or completeness. TI's customers are responsible for determining suitability of components for their purposes. Customers should validate and test their design implementation to confirm system functionality.

### 9.1 Application Information

The ESD224 is a diode type TVS which is used to provide a path to ground for dissipating ESD events on high-speed signal lines between a human interface connector and a system. As the current from ESD passes through the TVS, only a small voltage drop is present across the diode. Part of this voltage drop across the diode drops across the series element between the connector side pin and the system-side pin. Therefore, the effective voltage drop across the protected IC is smaller than the voltage drop across the diode. It is recommended to avoid through-routing for this ESD diode (single trace connecting both the connector side pin and the system side pin) for the best ESD performance.

### 9.2 Typical Application

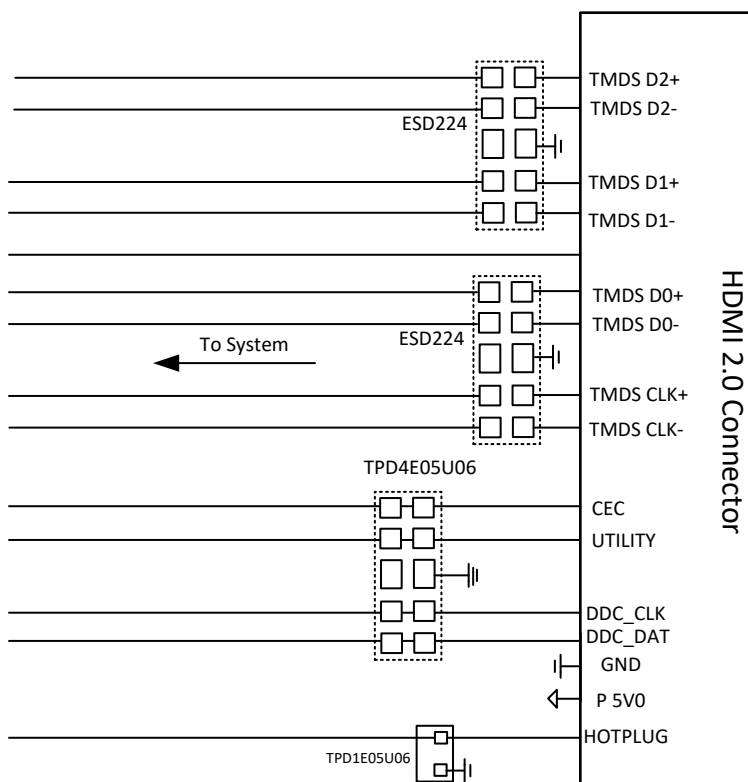

Copyright © 2018, Texas Instruments Incorporated

Figure 12. ESD224 Protecting the HDMI Interface

## Typical Application (continued)

### 9.2.1 Design Requirements

In this design example, two ESD224 devices, one TPD4E05U06 and one TPD1E05U06 device are used to protect an HDMI 2.0 interface. For HDMI 2.0 application design parameters listed in [Table 1](#) are known.

**Table 1. Design Parameters**

DESIGN PARAMETER	VALUE
Signal range on high speed differential data lines	0 to 3.6 V
Operating frequency of high speed data lines	3 GHz (First Harmonic)
Signal range on control lines (CEC, UTILITY, DDC_CLK and DDC_DAT)	0 to 5 V

### 9.2.2 Detailed Design Procedure

#### 9.2.2.1 Signal Range

ESD224 supports signal ranges between  $-3.6\text{ V}$  and  $3.6\text{ V}$ , which supports the high-speed lines on the HDMI 2.0 application. The TPD4E05U06 and TPD1E05U06 support signal ranges between  $0\text{ V}$  and  $5.5\text{ V}$ , which supports the HDMI control lines.

#### 9.2.2.2 Operating Frequency

The ESD224 has a  $0.5\text{ pF}$  (typical) capacitance, which supports the HDMI 2.0 rate of  $6\text{ Gbps}$ . The TPD4E05U06 and TPD1E05U06 have a typical capacitance of  $0.5\text{ pF}$  and  $0.42\text{ pF}$  respectively, which easily support the control lines. The ESD224 has 4 identical protection channels for the differential HDMI high-speed signal lines. The symmetrical pin out of the device with a ground pin between the two differential signal pins makes it suitable for this application.

### 9.2.3 Application Curves

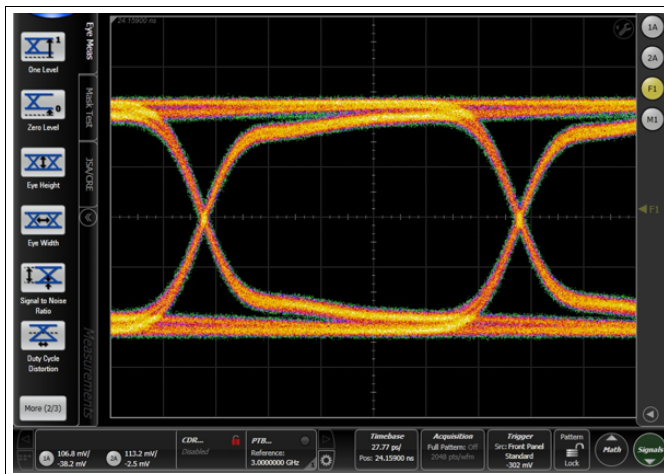

Figure 13. HDMI 2.0 6 Gbps Eye Diagram (Bare Board)

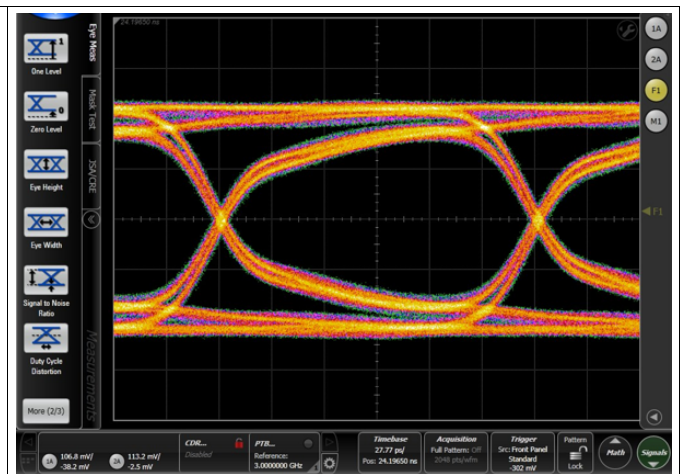

Figure 14. HDMI 2.0 6 Gbps Eye Diagram with ESD224

## 10 Power Supply Recommendations

This device is a passive ESD device so there is no need to power it. Take care not to violate the recommended I/O specification (–3.6 V to 3.6 V) to ensure the device functions properly.

## 11 Layout

### 11.1 Layout Guidelines

- The optimum placement is as close to the connector as possible.
  - EMI during an ESD event can couple from the trace being struck to other nearby unprotected traces, resulting in early system failures.
  - The PCB designer must minimize the possibility of EMI coupling by keeping any unprotected traces away from the protected traces which are between the TVS and the connector.
- For the best ESD performance, do not use through-routing for the data channels. Connecting pins 1 and 10, 2 and 9, 4 and 7, 5 and 6 together with through routing will reduce the clamping voltage performance of ESD224.
- Route the protected traces as straight as possible.
- Eliminate any sharp corners on the protected traces between the TVS and the connector by using rounded corners with the largest radii possible.
  - Electric fields tend to build up on corners, increasing EMI coupling.

## 11.2 Layout Examples

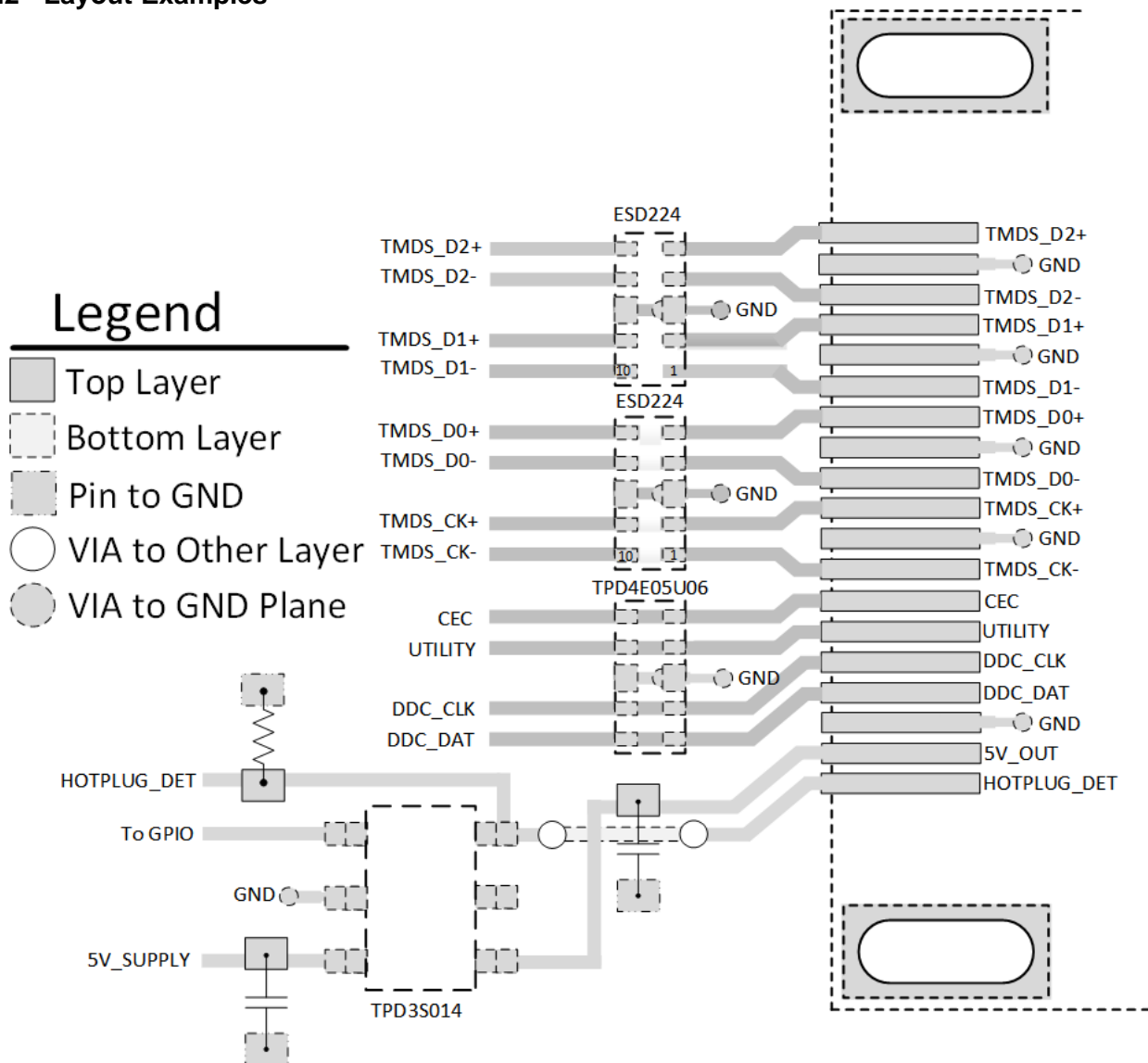

Figure 15. HDMI Type-A Transmitter Port Layout

**NOTE**

There is no Through-Routing for the ESD224 Pins Connecting to the High Speed Data Lines.

## 12 Device and Documentation Support

### 12.1 Documentation Support

#### 12.1.1 Related Documentation

For related documentation see the following:

### 12.2 Receiving Notification of Documentation Updates

To receive notification of documentation updates, navigate to the device product folder on [ti.com](http://ti.com). In the upper right corner, click on *Alert me* to register and receive a weekly digest of any product information that has changed. For change details, review the revision history included in any revised document.

### 12.3 Community Resources

The following links connect to TI community resources. Linked contents are provided "AS IS" by the respective contributors. They do not constitute TI specifications and do not necessarily reflect TI's views; see TI's [Terms of Use](#).

**TI E2E™ Online Community** *TI's Engineer-to-Engineer (E2E) Community*. Created to foster collaboration among engineers. At [e2e.ti.com](http://e2e.ti.com), you can ask questions, share knowledge, explore ideas and help solve problems with fellow engineers.

**Design Support** *TI's Design Support* Quickly find helpful E2E forums along with design support tools and contact information for technical support.

### 12.4 Trademarks

E2E is a trademark of Texas Instruments.

### 12.5 Electrostatic Discharge Caution



This integrated circuit can be damaged by ESD. Texas Instruments recommends that all integrated circuits be handled with appropriate precautions. Failure to observe proper handling and installation procedures can cause damage.

ESD damage can range from subtle performance degradation to complete device failure. Precision integrated circuits may be more susceptible to damage because very small parametric changes could cause the device not to meet its published specifications.

### 12.6 Glossary

[SLYZ022](#) — *TI Glossary*.

This glossary lists and explains terms, acronyms, and definitions.

## 13 Mechanical, Packaging, and Orderable Information

The following pages include mechanical, packaging, and orderable information. This information is the most current data available for the designated devices. This data is subject to change without notice and revision of this document. For browser-based versions of this data sheet, refer to the left-hand navigation.

**PACKAGING INFORMATION**

Orderable Device	Status (1)	Package Type	Package Drawing	Pins	Package Qty	Eco Plan (2)	Lead/Ball Finish (6)	MSL Peak Temp (3)	Op Temp (°C)	Device Marking (4/5)	Samples
ESD224DQAR	ACTIVE	USON	DQA	10	3000	Green (RoHS & no Sb/Br)	NIPDAU	Level-1-260C-UNLIM	-40 to 125	1AR	<a href="#">Samples</a>

(1) The marketing status values are defined as follows:

**ACTIVE:** Product device recommended for new designs.

**LIFEBUY:** TI has announced that the device will be discontinued, and a lifetime-buy period is in effect.

**NRND:** Not recommended for new designs. Device is in production to support existing customers, but TI does not recommend using this part in a new design.

**PREVIEW:** Device has been announced but is not in production. Samples may or may not be available.

**OBSOLETE:** TI has discontinued the production of the device.

(2) **RoHS:** TI defines "RoHS" to mean semiconductor products that are compliant with the current EU RoHS requirements for all 10 RoHS substances, including the requirement that RoHS substance do not exceed 0.1% by weight in homogeneous materials. Where designed to be soldered at high temperatures, "RoHS" products are suitable for use in specified lead-free processes. TI may reference these types of products as "Pb-Free".

**RoHS Exempt:** TI defines "RoHS Exempt" to mean products that contain lead but are compliant with EU RoHS pursuant to a specific EU RoHS exemption.

**Green:** TI defines "Green" to mean the content of Chlorine (Cl) and Bromine (Br) based flame retardants meet JS709B low halogen requirements of <=1000ppm threshold. Antimony trioxide based flame retardants must also meet the <=1000ppm threshold requirement.

(3) MSL, Peak Temp. - The Moisture Sensitivity Level rating according to the JEDEC industry standard classifications, and peak solder temperature.

(4) There may be additional marking, which relates to the logo, the lot trace code information, or the environmental category on the device.

(5) Multiple Device Markings will be inside parentheses. Only one Device Marking contained in parentheses and separated by a "~" will appear on a device. If a line is indented then it is a continuation of the previous line and the two combined represent the entire Device Marking for that device.

(6) Lead/Ball Finish - Orderable Devices may have multiple material finish options. Finish options are separated by a vertical ruled line. Lead/Ball Finish values may wrap to two lines if the finish value exceeds the maximum column width.

**Important Information and Disclaimer:**The information provided on this page represents TI's knowledge and belief as of the date that it is provided. TI bases its knowledge and belief on information provided by third parties, and makes no representation or warranty as to the accuracy of such information. Efforts are underway to better integrate information from third parties. TI has taken and continues to take reasonable steps to provide representative and accurate information but may not have conducted destructive testing or chemical analysis on incoming materials and chemicals. TI and TI suppliers consider certain information to be proprietary, and thus CAS numbers and other limited information may not be available for release.

In no event shall TI's liability arising out of such information exceed the total purchase price of the TI part(s) at issue in this document sold by TI to Customer on an annual basis.

**TAPE AND REEL INFORMATION**

**QUADRANT ASSIGNMENTS FOR PIN 1 ORIENTATION IN TAPE**

\*All dimensions are nominal

Device	Package Type	Package Drawing	Pins	SPQ	Reel Diameter (mm)	Reel Width W1 (mm)	A0 (mm)	B0 (mm)	K0 (mm)	P1 (mm)	W (mm)	Pin1 Quadrant
ESD224DQAR	USON	DQA	10	3000	180.0	8.4	1.23	2.7	0.6	4.0	8.0	Q1

**TAPE AND REEL BOX DIMENSIONS**

\*All dimensions are nominal

Device	Package Type	Package Drawing	Pins	SPQ	Length (mm)	Width (mm)	Height (mm)
ESD224DQAR	USON	DQA	10	3000	203.2	196.8	33.3



# EXAMPLE BOARD LAYOUT

DQA0010A

USON - 0.55 mm max height

PLASTIC SMALL OUTLINE - NO LEAD

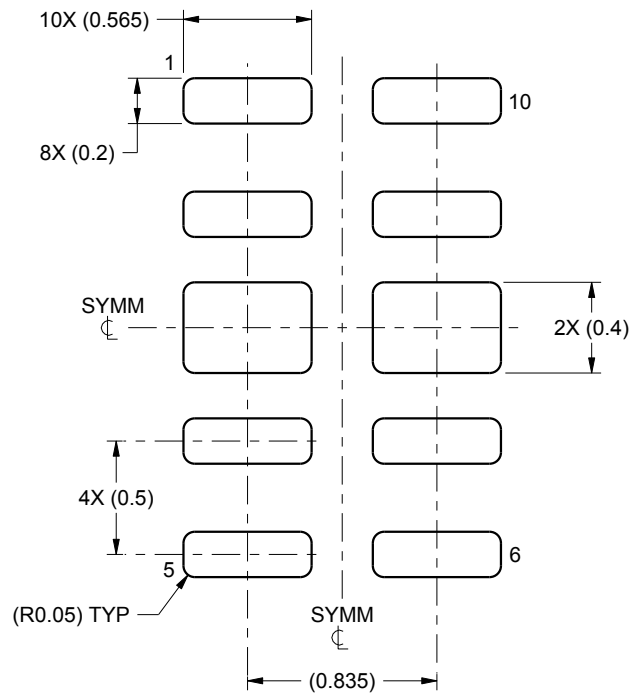

LAND PATTERN EXAMPLE  
SCALE:30X

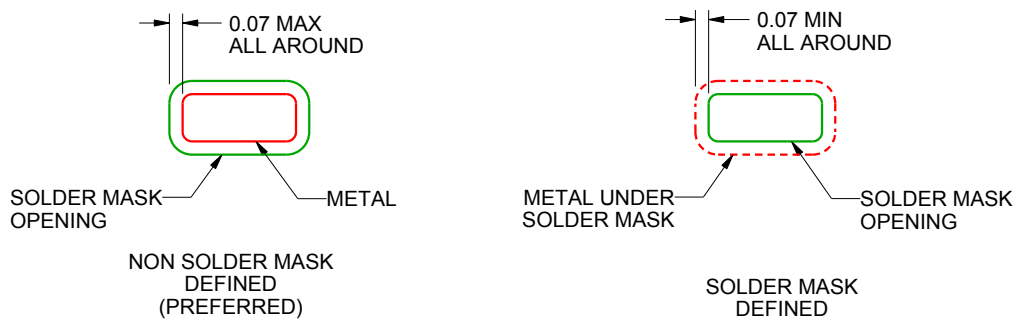

SOLDER MASK DETAILS

4220328/A 12/2015

NOTES: (continued)

3. For more information, see Texas Instruments literature number SLUA271 ([www.ti.com/lit/slua271](http://www.ti.com/lit/slua271)).

# EXAMPLE STENCIL DESIGN

DQA0010A

USON - 0.55 mm max height

PLASTIC SMALL OUTLINE - NO LEAD

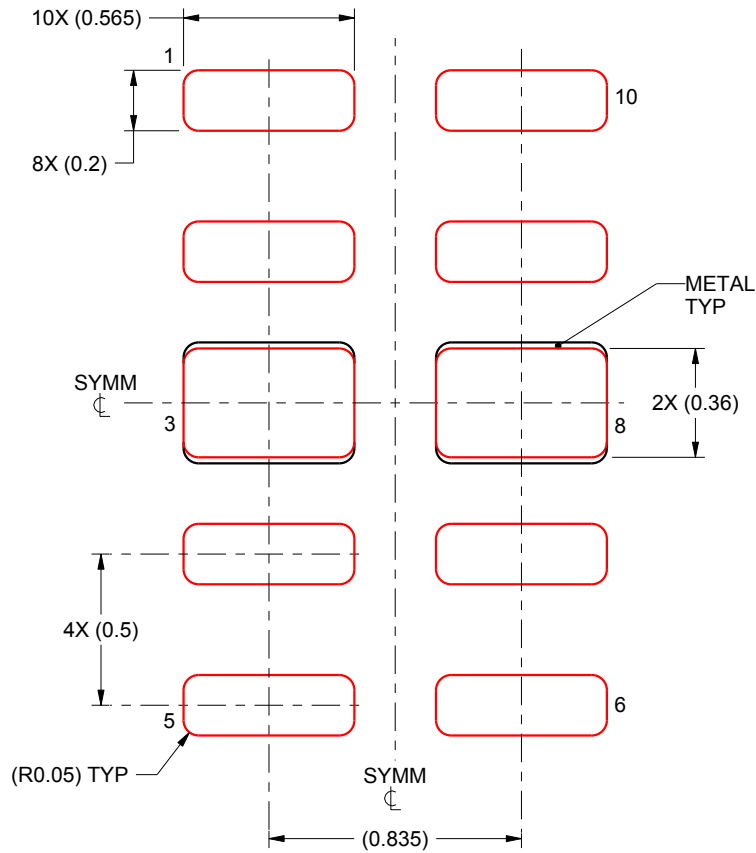

SOLDER PASTE EXAMPLE  
BASED ON 0.1 mm THICK STENCIL

EXPOSED PADS 3 & 8:  
90% PRINTED SOLDER COVERAGE BY AREA UNDER PACKAGE  
SCALE:40X

4220328/A 12/2015

NOTES: (continued)

4. Laser cutting apertures with trapezoidal walls and rounded corners may offer better paste release. IPC-7525 may have alternate design recommendations.

## IMPORTANT NOTICE AND DISCLAIMER

TI PROVIDES TECHNICAL AND RELIABILITY DATA (INCLUDING DATASHEETS), DESIGN RESOURCES (INCLUDING REFERENCE DESIGNS), APPLICATION OR OTHER DESIGN ADVICE, WEB TOOLS, SAFETY INFORMATION, AND OTHER RESOURCES "AS IS" AND WITH ALL FAULTS, AND DISCLAIMS ALL WARRANTIES, EXPRESS AND IMPLIED, INCLUDING WITHOUT LIMITATION ANY IMPLIED WARRANTIES OF MERCHANTABILITY, FITNESS FOR A PARTICULAR PURPOSE OR NON-INFRINGEMENT OF THIRD PARTY INTELLECTUAL PROPERTY RIGHTS.

These resources are intended for skilled developers designing with TI products. You are solely responsible for (1) selecting the appropriate TI products for your application, (2) designing, validating and testing your application, and (3) ensuring your application meets applicable standards, and any other safety, security, or other requirements. These resources are subject to change without notice. TI grants you permission to use these resources only for development of an application that uses the TI products described in the resource. Other reproduction and display of these resources is prohibited. No license is granted to any other TI intellectual property right or to any third party intellectual property right. TI disclaims responsibility for, and you will fully indemnify TI and its representatives against, any claims, damages, costs, losses, and liabilities arising out of your use of these resources.

TI's products are provided subject to TI's Terms of Sale ([www.ti.com/legal/termsofsale.html](http://www.ti.com/legal/termsofsale.html)) or other applicable terms available either on [ti.com](http://ti.com) or provided in conjunction with such TI products. TI's provision of these resources does not expand or otherwise alter TI's applicable warranties or warranty disclaimers for TI products.

Mailing Address: Texas Instruments, Post Office Box 655303, Dallas, Texas 75265  
Copyright © 2020, Texas Instruments Incorporated