

## BlueTile – Bluetooth LE enabled sensor node development kit

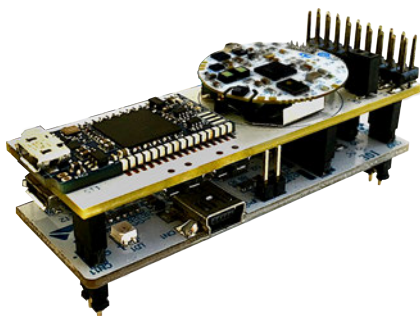

### Features

- **STEVAL-BCN002V1B** evaluation kit with STEVAL-BCN002V1 sensor board and STEVAL-BCN002V1D programming board.
- STEVAL-BCN002V1 sensor board:
  - **BlueNRG-2**: Bluetooth Low Energy single-mode system-on-chip
  - **BALF-NRG-02D3**: ultra-miniature balun and harmonic filter
  - **LSM6DSO**: iNEMO 6DoF inertial module, ultra-low power and high accuracy
  - **LIS2MDL**: magnetic sensor, digital output, 50 gauss magnetic field dynamic range, ultra-low power, high performance, 3-axis magnetometer
  - **VL53L1X**: long range Time-of-Flight sensor based on ST FlightSense technology
  - **MP34DT05TR-A**: MEMS audio sensor omnidirectional digital microphone, 64 dB SNR, -26 dBFS sensitivity, top-port, 122.5 dB SPL AOP
  - **LPS22HH**: ultra-compact piezo-resistive absolute pressure sensor, 260-1260 hPa, digital output barometer, full-mold dust resistant, holed LGA package (HLGA)
  - **HTS221**: capacitive digital sensor for relative humidity and temperature
  - CR2032 battery powered (not included)
- STEVAL-BCN002V1D programming board:
  - program and debug firmware running on sensor board
  - supply power to the sensor board
- **ST BLE Sensor** app available on Android (Google Play) and iOS (iTunes)
- Target Applications:
  - Internet of Things, Smart Building, Home and City
  - Tracking System, Supply Chain/ Cold-Chain Management
  - Smart Agriculture (soil control, animal activity tracking, etc.)

### Description

The **STEVAL-BCN002V1B** Bluetooth LE enabled sensor node development kit features the STEVAL-BCN002V1 multi-sensor board based on BlueNRG-2 SoC Bluetooth Low Energy application processor. This sensor board has accelerometer, gyroscope, magnetometer, pressure, humidity, Time-of-Flight and microphone sensors, and is powered by a common CR2032 coin battery.

The sensor board communicates with a Bluetooth LE enabled smartphone running the **ST BLE Sensor** app, available on Google Play and iTunes stores.

The STEVAL-BCN002V1D adapter board is used to program and debug the sensor board. The adapter board is powered via USB.

Product summary	
Bluetooth LE enabled sensor node development kit	<b>STEVAL-BCN002V1B</b>
Sensor board with Bluetooth LE SoC and a range of sensors	STEVAL-BCN002V1
Adapter and programming board	STEVAL-BCN002V1D
BLE sensor application for Android and iOS	<b>ST BLE Sensor</b>

# 1 Component layout

**Figure 1. STEVAL-BCN002V1 sensor node front and rear components**

- 1a. BlueNRG-2 Bluetooth 5.0 network and application processor
  - 1b. BALF-NRG-02D3 integrated balun and matching network
  - 2a. LPS22HH ambient pressure sensor
  - 2b. LSM6DSO smart accelerometer and gyroscope
  - 2c. LIS2MDL magnetometer
  - 2d. VL53L1X proximity by time-of-flight
  - 2e. HTS221 relative humidity and temperature
  - 2f. MP34DT05-A top-port digital microphone
  - 3a. User button
  - 3b. RGB LED
  - 4a. I2C SCL
  - 4b. I2C SDA
  - 4c. GND
  - 4d. ADC
  - 4e. TEST
  - 4f. VDD
  - 4g. GND
  - 4h. RFTTEST
  - 5a. I1-network (not mounted)
  - 5b. SMD antenna
  - 6a. Inductor to enable lowest power BLE active mode
  - 6b. 32kHz crystal to enable lowest power BLE sleep mode
  - 7a. Battery holder
  - 7b. CR2032 battery (not included)
  - 8. 10-pin connector
- FCC ID: S9NSTEBCN2V1 IC ID: 8976C-STEBCN2V1

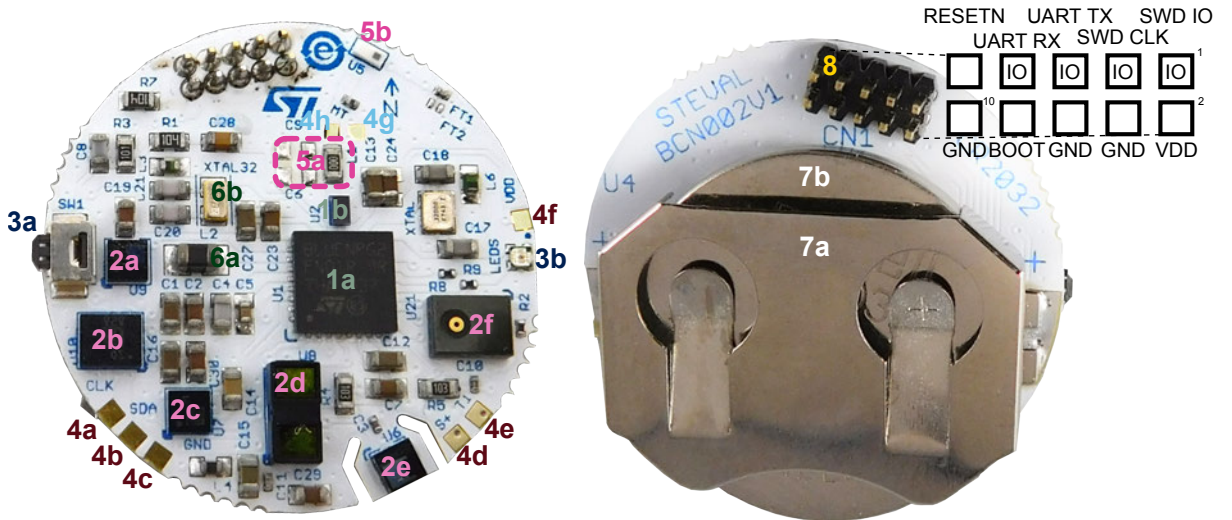
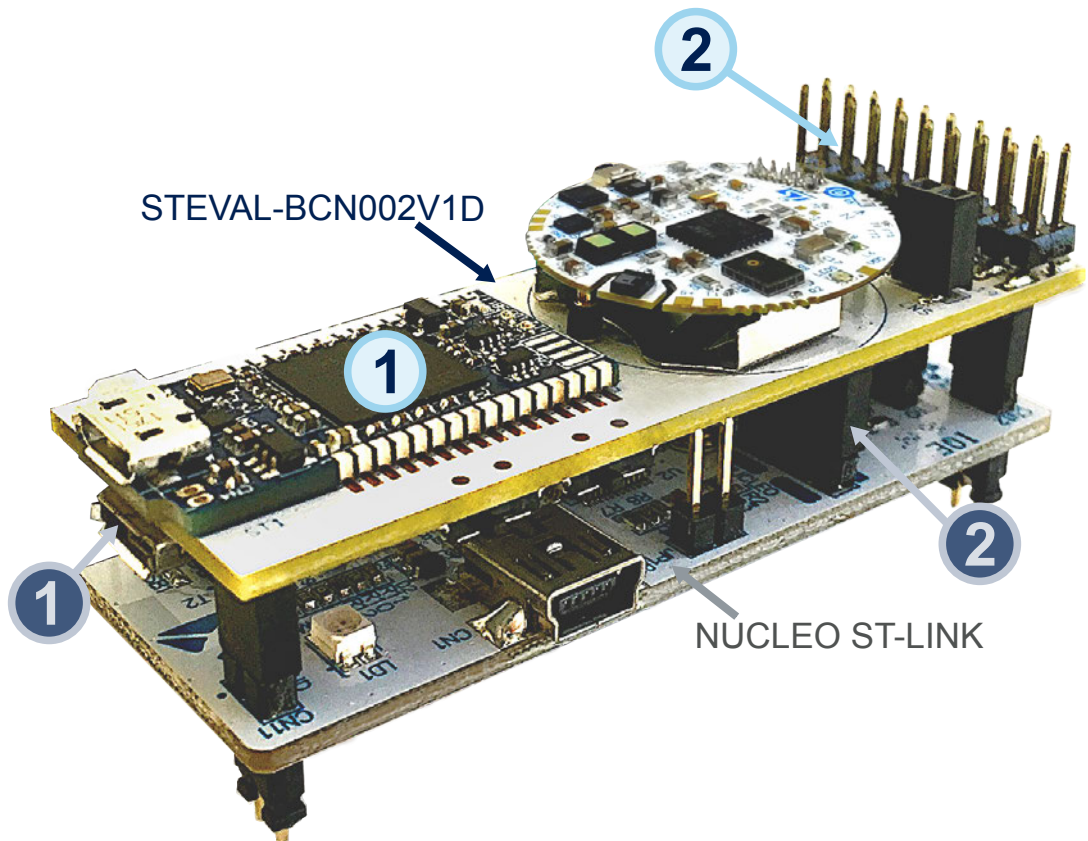

**Figure 2. STEVAL-BCN002V1D host board for programming and debugging**
**Top side components:**

1. ST-LINK V3 debugger
2. 20 pin JTAG/SWD for ext. ST-LINK V2

**Bottom side components:**

1. VCOM for STM32L151
2. 5 pin JTAG/SWD for Nucleo ST-LINK



## 2 Schematic diagrams

---

## 2.1 STEVAL-BCN002V1 sensor board schematics

Figure 3. STEVAL-BCN002V1 schematic (1 of 3)

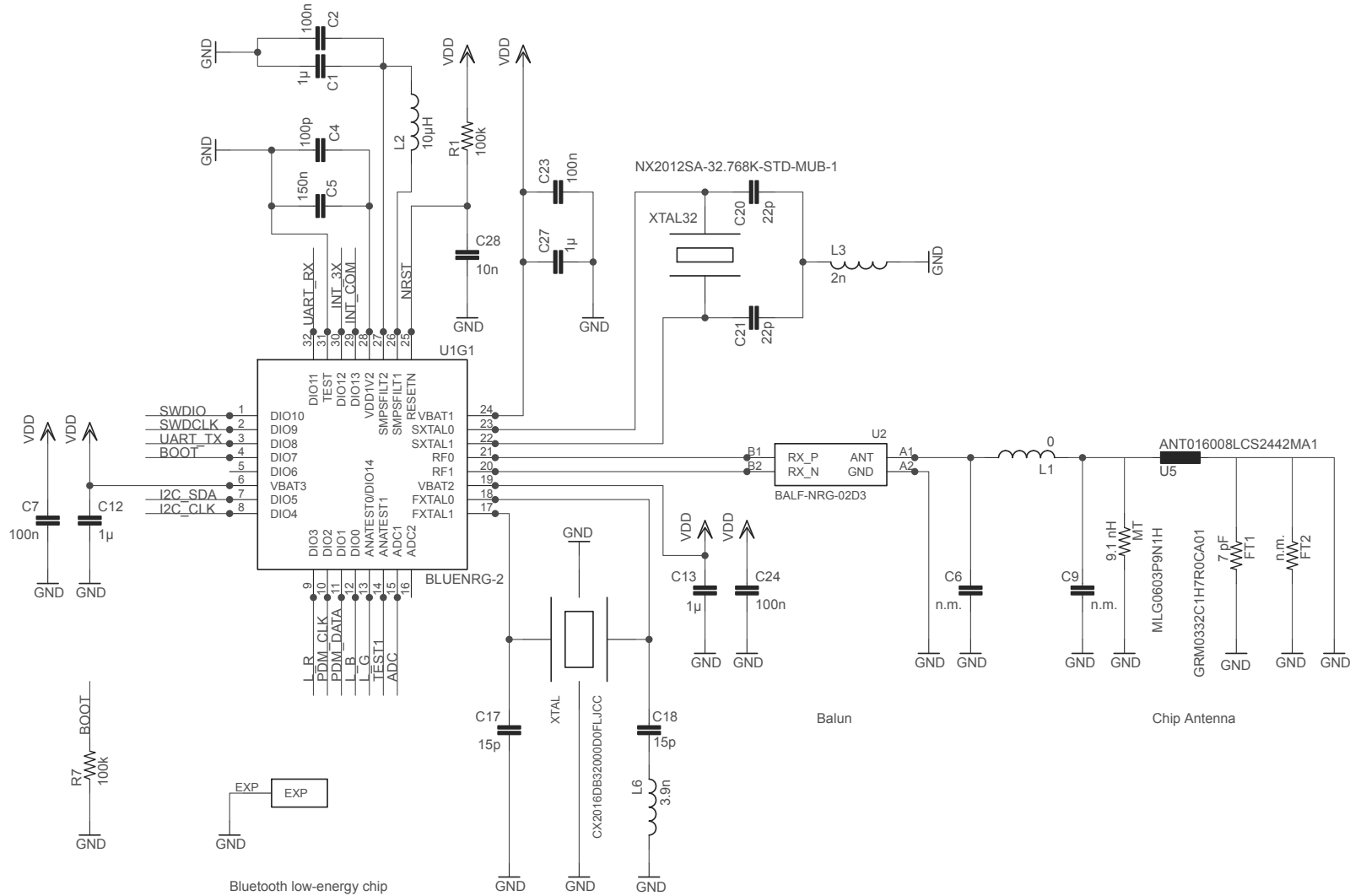

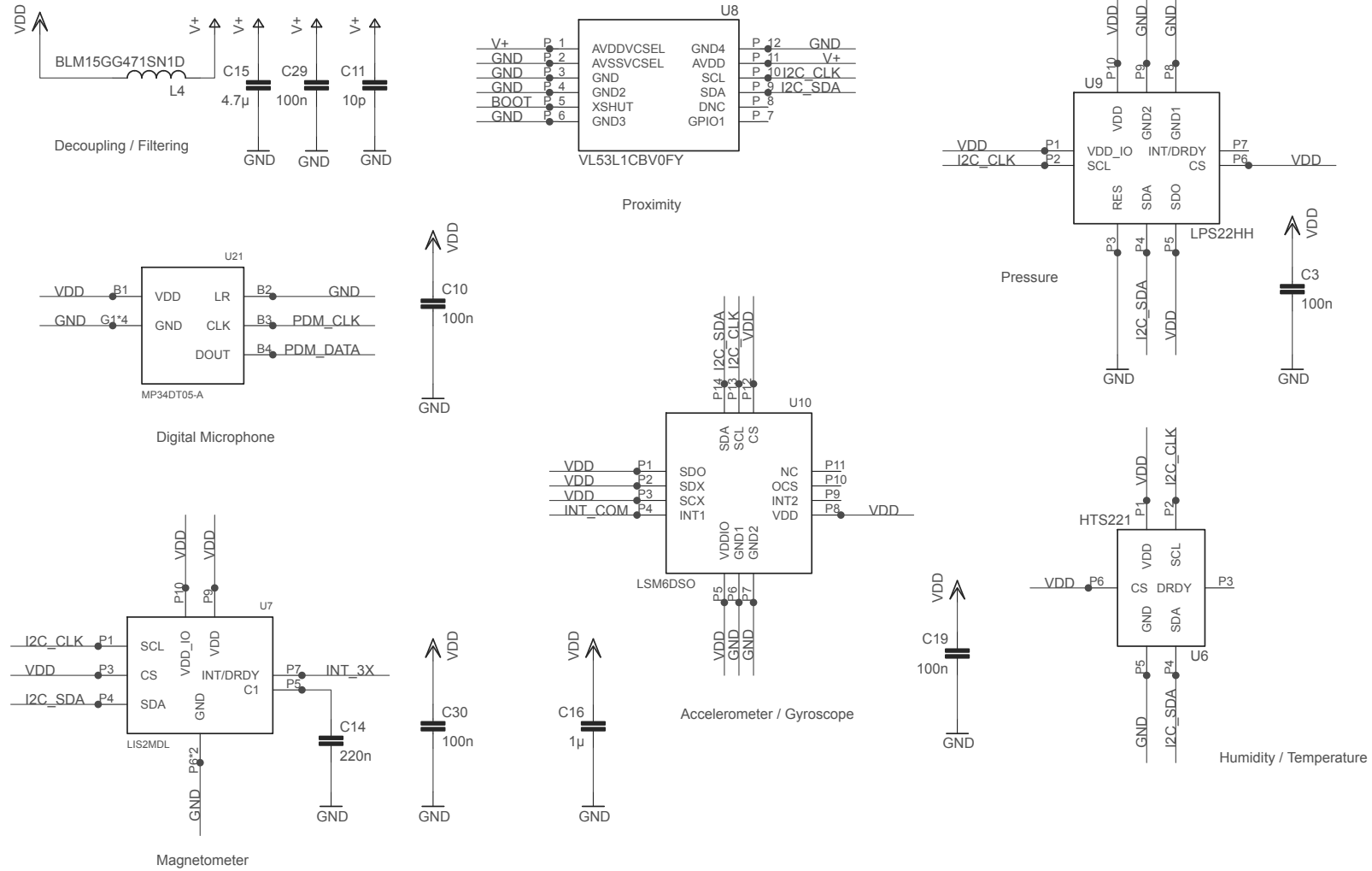
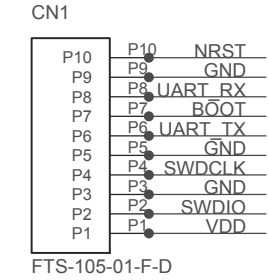

Figure 4. STEVAL-BCN002V1 schematic (2 of 3)

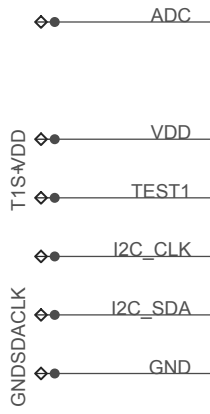

Figure 5. STEVAL-BCN002V1 schematic (3 of 3)



FTS-105-01-F-D

ARM10 debug connector



Test points

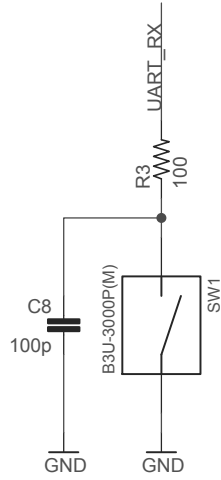

Push button

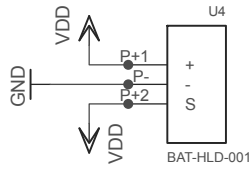

CR2032 3 V battery

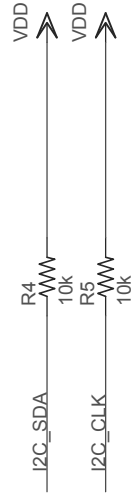

Pull-ups

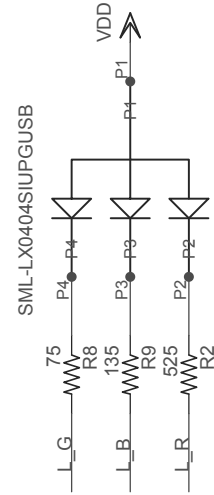

RGB LED



## 2.2 STEVAL-BCN002V1D programming board schematics

Figure 6. STEVAL-BCN002V1D schematic (1 of 3)

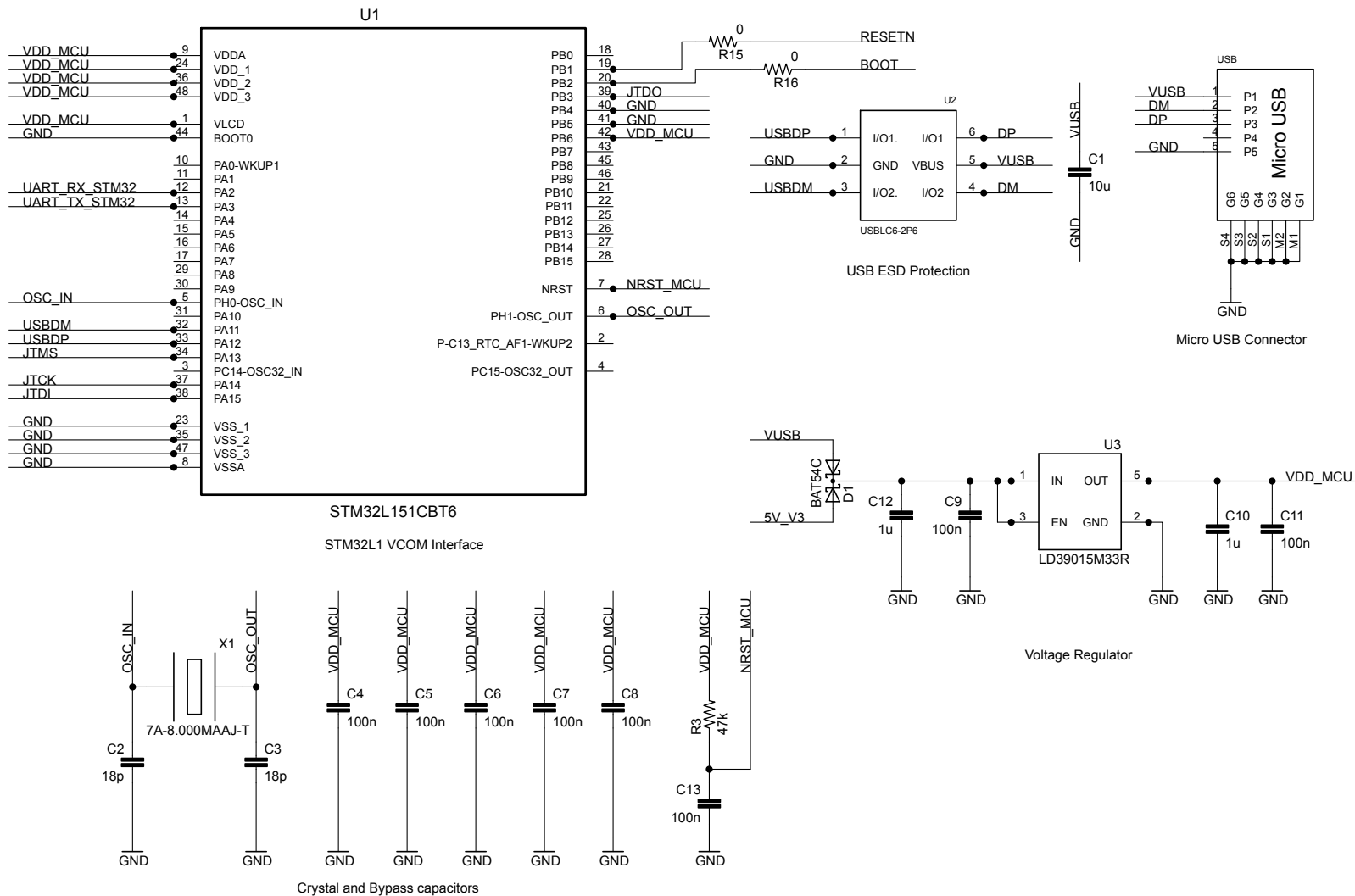

Figure 7. STEVAL-BCN002V1D schematic (2 of 3)

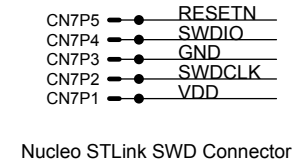
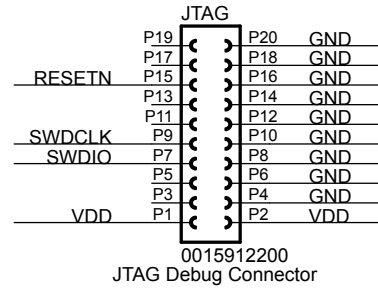
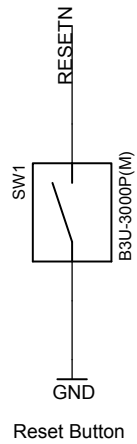
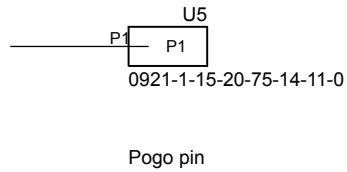
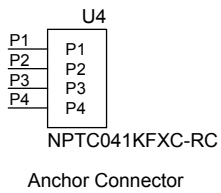
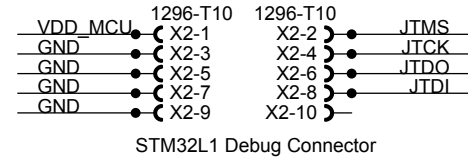
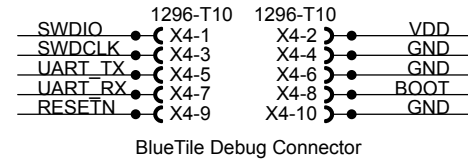
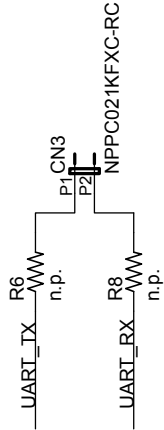
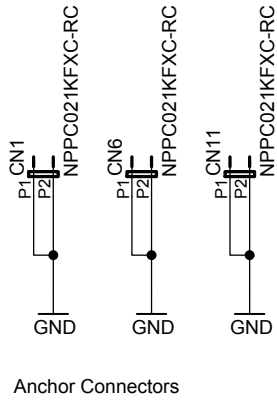
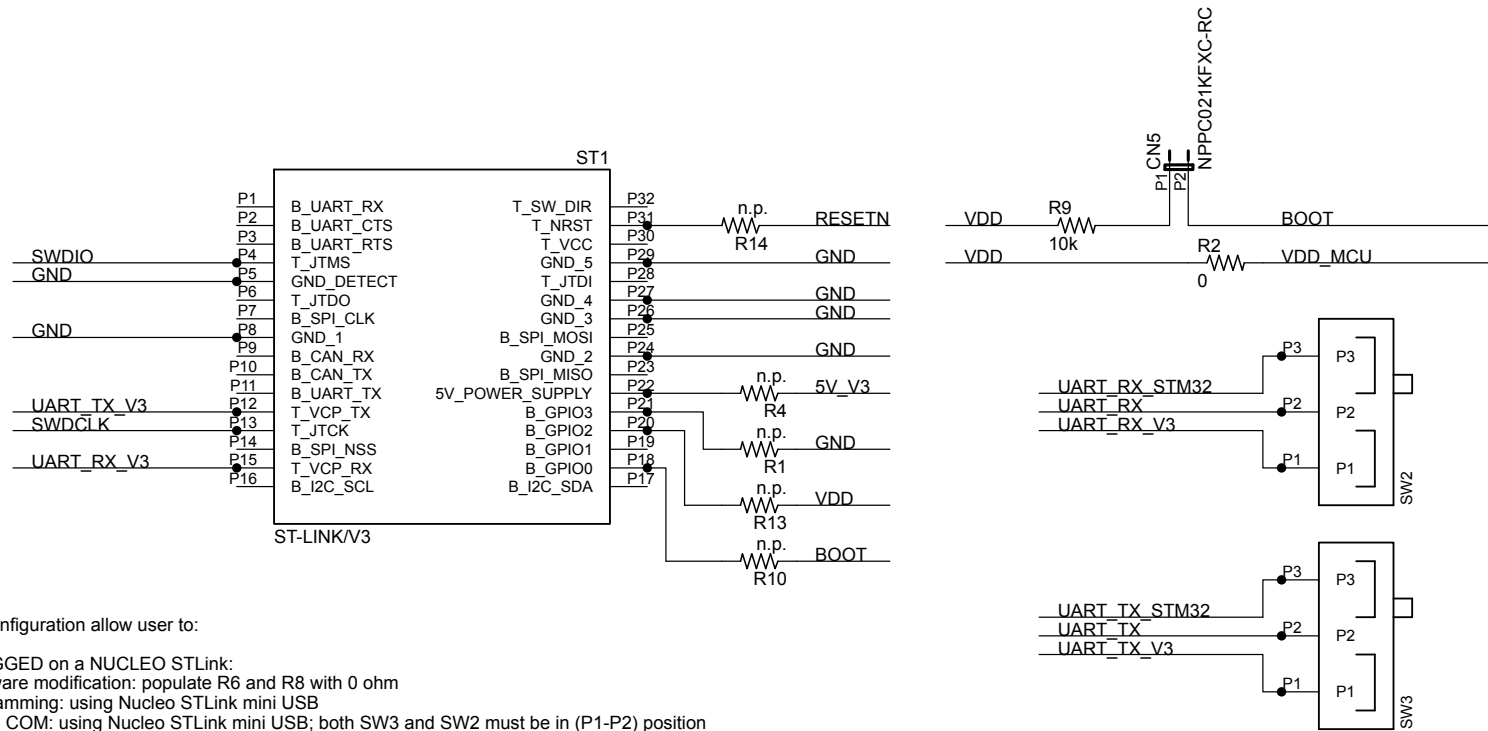

Figure 8. STEVAL-BCN002V1D schematic (3 of 3)



Default configuration allow user to:

- 1) If PLUGGED on a NUCLEO STLink:
  - Hardware modification: populate R6 and R8 with 0 ohm
  - Programming: using Nucleo STLink mini USB
  - Virtual COM: using Nucleo STLink mini USB; both SW3 and SW2 must be in (P1-P2) position
- 2) If using an EXTERNAL JTAG debugger:
  - Programming: using JTAG connector on top
  - Virtual COM: using micro USB connector on the bottom; both SW3 and SW2 must be in (P2-P3) position
- 3) If using the INTEGRATED USB to UART interface:
  - Programming: using micro USB connector on the bottom and only using BlueNRG-1 Flasher Utility
  - Virtual COM: using micro USB connector on the bottom; both SW3 and SW2 must be in (P2-P3) position
- 4) If using the INTEGRATED ST-LINK/V3:
  - Hardware modification: populate R4 and R14 with 0 ohm
  - Programming: using ST-LINK/V3 SWD
  - Virtual COM: using ST-LINK/V3 micro USB; both SW3 and SW2 must be in (P1-P2) position

### 3 How to set up the STEVAL-BCN002V1D board

Use the configurations below to set up the STEVAL-BCN002V1D board according to your requirements.

If plugged on a NUCLEO ST-LINK board:

- Step 1.** Place 0  $\Omega$  resistors (short) on R6 and R8.
- Step 2.** For programming: load the firmware via the NUCLEO ST-LINK mini USB connector.
- Step 3.** For virtual COM: use the NUCLEO ST-LINK mini USB connector.  
SW3 and SW2 can be in any position.

If using an external JTAG debugger:

- Step 4.** For programming: use the JTAG connector on the top side of the STEVAL-BCN002V1D board.
- Step 5.** For virtual COM: use the micro USB connector on the bottom side of the STEVAL-BCN002V1D board.  
SW3 and SW2 can be in any position.

If using the integrated USB to UART interface:

- Step 6.** For programming: use the micro USB connector on the bottom and use the BlueNRG-1 Flasher Utility only.
- Step 7.** For virtual COM: use the micro USB connector on the bottom side of the STEVAL-BCN002V1D board.  
Both SW3 and SW2 must be in (P2-P3) position.

If using the integrated ST-LINK/V3:

- Step 8.** Place 0  $\Omega$  resistors (short) on R4 and R14.
- Step 9.** For programming: use the ST-LINK/V3 SWD.
- Step 10.** For virtual COM: use the ST-LINK/V3 micro USB.  
Both SW3 and SW2 must be in (P1-P2) position.

## 4 Certification

### 4.1 Regulatory compliance

**Table 1. RF certification summary**

Certification	ID	Comment
FCC	S9NSTEBCN2V1 (PENDING)	On-board SMD antenna
IC	8976C-STEBCN2V1 (PENDING)	On-board SMD antenna
ETSI	0051-RED-0010 REV.0 (PENDING)	On-board SMD antenna

### 4.2 FCC and IC

The STEVAL-BCN002V1B kit has been tested and complies with the FCC part 15 and IC RSS-210 regulations. These limits are designed to provide reasonable protection against harmful interference in approved installations. This equipment generates, uses, and can radiate radio frequency energy and, if not installed and used in accordance with the instructions, may cause harmful interference to radio communications.

However, there is no guarantee that interference will not occur in a particular installation.

This device complies with part 15 of the FCC rules. Operation is subject to the following two conditions:

1. The device must not cause harmful interference.
2. The device must accept any interference received, including interference that may cause undesired operation.

Modifications or changes to this equipment not expressly approved by the party responsible for compliance may render void the user's authority to operate this equipment.

### 4.3 CE

STEVAL-BCN002V1B kit complies with the following European EMI/EMC and safety directives and standards:

- EN 300 328 V 2.1.1 (2016-11) (a)
- ETSI EN 301 489-17 V3.1.1 (2017-02) (b)
- ETSI EN 301 489-1 V2.1.1 (2017-02) (c)
- EN 60950-1:2006 + A11:2009 + A1:2010 + A12:2011 + A2:2013 (d)
- EN 62479:2010

The module has the CE marking:

**Figure 9. CE marking**



The module has obtained the RED certificate: No. 0051-RED-0010 REV. 0

The certified module production firmware release is: 1.X

For additional information please refer to:

STMicroelectronics Via C. Olivetti, 2 Agrate Brianza 20864 (ITALY)

## Revision history

**Table 2. Document revision history**

Date	Version	Changes
06-Aug-2018	1	Initial release.
07-Aug-2018	2	Minor text changes.
18-Oct-2018	3	Updated Section 2 Schematic diagrams.
13-Nov-2018	4	Updated cover page image. Updated Figure 1 and Figure 2.
06-Feb-2019	5	Updated title. Added references to STBLESensor app.
04-Mar-2019	6	Minor text edits Added <a href="#">Section 2.2 STEVAL-BCN002V1D programming board schematics</a>

## Contents

<b>1</b>	<b>Component layout</b> .....	<b>2</b>
<b>2</b>	<b>Schematic diagrams</b> .....	<b>4</b>
<b>2.1</b>	STEVAL-BCN002V1 sensor board schematics .....	5
<b>2.2</b>	STEVAL-BCN002V1D programming board schematics .....	8
<b>3</b>	<b>How to set up the STEVAL-BCN002V1D board</b> .....	<b>11</b>
<b>4</b>	<b>Certification</b> .....	<b>12</b>
<b>4.1</b>	Regulatory compliance .....	12
<b>4.2</b>	FCC and IC .....	12
<b>4.3</b>	CE .....	12
	<b>Revision history</b> .....	<b>13</b>

## List of figures

<b>Figure 1.</b>	STEVAL-BCN002V1 sensor node front and rear components . . . . .	2
<b>Figure 2.</b>	STEVAL-BCN002V1D host board for programming and debugging . . . . .	3
<b>Figure 3.</b>	STEVAL-BCN002V1 schematic (1 of 3) . . . . .	5
<b>Figure 4.</b>	STEVAL-BCN002V1 schematic (2 of 3) . . . . .	6
<b>Figure 5.</b>	STEVAL-BCN002V1 schematic (3 of 3) . . . . .	7
<b>Figure 6.</b>	STEVAL-BCN002V1D schematic (1 of 3) . . . . .	8
<b>Figure 7.</b>	STEVAL-BCN002V1D schematic (2 of 3) . . . . .	9
<b>Figure 8.</b>	STEVAL-BCN002V1D schematic (3 of 3) . . . . .	10
<b>Figure 9.</b>	CE marking . . . . .	12

## List of tables

<b>Table 1.</b>	RF certification summary .....	12
<b>Table 2.</b>	Document revision history .....	13

**IMPORTANT NOTICE – PLEASE READ CAREFULLY**

STMicroelectronics NV and its subsidiaries (“ST”) reserve the right to make changes, corrections, enhancements, modifications, and improvements to ST products and/or to this document at any time without notice. Purchasers should obtain the latest relevant information on ST products before placing orders. ST products are sold pursuant to ST’s terms and conditions of sale in place at the time of order acknowledgement.

Purchasers are solely responsible for the choice, selection, and use of ST products and ST assumes no liability for application assistance or the design of Purchasers’ products.

No license, express or implied, to any intellectual property right is granted by ST herein.

Resale of ST products with provisions different from the information set forth herein shall void any warranty granted by ST for such product.

ST and the ST logo are trademarks of ST. All other product or service names are the property of their respective owners.

Information in this document supersedes and replaces information previously supplied in any prior versions of this document.

© 2019 STMicroelectronics – All rights reserved