

Introduction

The STM32H7 Nucleo-144 boards based on the MB1363 reference board (NUCLEO-H745ZI-Q, NUCLEO-H755ZI-Q, NUCLEO-H7A3ZI-Q) provide an affordable and flexible way for users to try out new concepts and build prototypes, by choosing from the various combinations of performance and power-consumption features provided by the STM32H7 microcontroller. The ST Zio connector, which extends the ARDUINO® Uno V3 connectivity, and the ST morpho headers provide an easy means of expanding the functionality of the Nucleo open development platform with a wide choice of specialized shields. The STM32H7 Nucleo-144 boards do not require any separate probe as they integrate the STLINK-V3E debugger/programmer. The STM32H7 Nucleo-144 boards come with the comprehensive free software libraries and examples available with the STM32Cube MCU Package.

Figure 1. Nucleo-144 board (Top view)

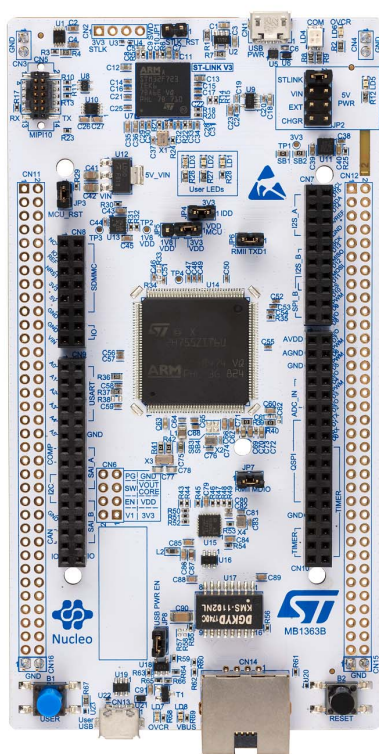
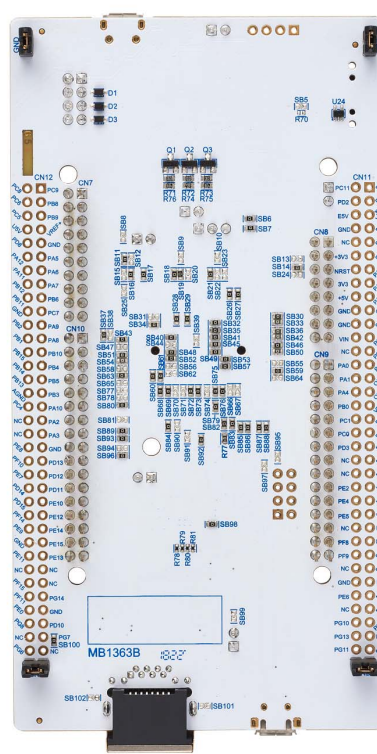

Figure 2. Nucleo-144 board (Bottom view)



Pictures are not contractual.

Contents

- 1 Features 6**
- 2 Ordering information 7**
 - 2.1 Product marking 7
 - 2.2 Codification 7
- 3 Development environment 8**
 - 3.1 Development toolchains 8
 - 3.2 System requirements 8
 - 3.3 Demonstration software 8
- 4 Conventions 9**
- 5 Quick start 10**
 - 5.1 Getting started 10
- 6 Hardware layout and configuration 11**
 - 6.1 Nucleo-144 board layout 12
 - 6.2 Mechanical drawing 13
 - 6.3 Program and debug the onboard STM32H7 target 15
 - 6.3.1 Using the STLINK-V3E to program and debug the onboard STM32H7 15
 - 6.3.2 Using an external debug tool to program and debug the onboard STM32H7 16
 - 6.4 Power supply and power selection 17
 - 6.4.1 Power supply input from STLINK-V3E USB connector (Default setting) 17
 - 6.4.2 External power supply input from V_{IN} (7-11 V, 800 mA max) 18
 - 6.4.3 External power supply input 5V_EXT (5 V, 500 mA max) 19
 - 6.4.4 External power supply input from USB CHARGER (5V) 20
 - 6.4.5 External power supply input from 3V3_EXT (3.3 V) 20
 - 6.4.6 Debugging while using V_{IN} or EXT as an external power supply 21
 - 6.4.7 External power supply output 22
 - 6.4.8 Internal SMPS / LDO Configuration 22
 - 6.4.9 JP5: 1.8 V / 3.3 V selection 25
 - 6.5 External SMPS selection 25

6.6	LEDs	26
6.7	Push-buttons	27
6.8	JP4 (IDD)	27
6.9	OSC clock	27
6.9.1	OSC clock supply	27
6.9.2	OSC 32 KHz	28
6.10	USART communication	28
6.11	USB OTG FS or device	29
6.12	Ethernet (With NUCLEO-H745ZI-Q and NUCLEO-H755ZI-Q)	30
6.13	Motor control	31
6.14	Solder bridges	31
6.15	Extension connectors	35
6.16	ST Zio connectors	36
6.17	ST morpho connector	45
Appendix A Assembly drawings		47
Appendix B Federal Communications Commission (FCC) and Industry Canada (IC) Compliance		49
B.1	FCC Compliance Statement	49
B.1.1	Part 15.19	49
B.1.2	Part 15.105	49
B.1.3	Part 15.21	49
B.2	IC Compliance Statement	49
B.2.1	Compliance Statement	49
B.2.2	Déclaration de conformité	50
7	Revision history	51

List of tables

Table 1.	Ordering information	7
Table 2.	Codification explanation	7
Table 3.	ON/OFF conventions	9
Table 4.	MIPI-10 debug connector (CN5)	17
Table 5.	External power sources: V_{IN} (7-11 V)	19
Table 6.	External power sources: 5V_EXT	19
Table 7.	External power sources: CHGR (5 V)	20
Table 8.	External power sources: 3V3_EXT (3.3 V)	21
Table 9.	External power sources maximum currents	22
Table 10.	SMPS / LDO configuration	22
Table 11.	External SMPS selection	25
Table 12.	USART3 pins	29
Table 13.	USB pin configuration	29
Table 14.	Ethernet pin configuration	30
Table 15.	Motor-control shield configuration	31
Table 16.	Solder bridges	31
Table 17.	NUCLEO-H745ZI-Q and NUCLEO-H755ZI-Q pin assignments	37
Table 18.	NUCLEO-H7A3ZI-Q pin assignments	41
Table 19.	Pin assignment of MCU with ST morpho connector	45
Table 20.	Document revision history	51

List of figures

Figure 1.	Nucleo-144 board (Top view)	1
Figure 2.	Nucleo-144 board (Bottom view)	1
Figure 3.	Hardware block diagram	11
Figure 4.	Nucleo-144 board top layout.	12
Figure 5.	Nucleo-144 board mechanical drawing in millimeter	13
Figure 6.	Nucleo-144 board mechanical drawing in mil	14
Figure 7.	USB composite device	16
Figure 8.	Power supply input from ST-LINK USB connector with PC (5 V, 500 mA max)	18
Figure 9.	Power supply input from V_{IN} (7-11 V, 800 mA max)	19
Figure 10.	Power supply input from 5V_EXT (5 V, 500 mA max)	20
Figure 11.	Power supply input from ST-LINK USB connector with a USB charger (5 V)	20
Figure 12.	Power supply input from 3V3V_EXT (3.3 V)	21
Figure 13.	Supply configuration 1: Internal LDO only	23
Figure 14.	Supply configuration 2: Internal SMPS only (Default)	23
Figure 15.	Supply configuration 3: Internal SMPS and LDO cascaded	24
Figure 16.	Supply configuration 4: Bypass	24
Figure 17.	NUCLEO-H745ZI-Q and NUCLEO-H755ZI-Q extension connectors	35
Figure 18.	NUCLEO-H7A3ZI-Q extension connectors	36
Figure 19.	Top assembly drawing	47
Figure 20.	Bottom assembly drawing.	48

1 Features

The STM32H7 Nucleo-144 boards offer the following features:

- STM32H7 Arm^{®(a)} Cortex[®] core-based microcontroller in LQFP144 package
- Ethernet compliant with IEEE-802.3-2002 (Depending on STM32H7 support)
- USB OTG or full-speed device
- 3 user LEDs
- 2 push-buttons: user and reset
- LSE crystal:
 - 32.768 kHz crystal oscillator
- Board connectors:
 - USB with Micro-AB
 - Ethernet RJ45 (Only for NUCLEO-H745ZI-Q and NUCLEO-H755ZI-Q)
- Board expansion connectors:
 - ST Zio including ARDUINO[®] Uno V3
 - ST morpho
- Flexible power-supply options: ST-LINK USB V_{BUS} or external sources
- Onboard STLINK-V3E debugger/programmer with SWD connector:
 - USB re-enumeration capability: virtual COM port, mass storage, debug port
 - STLINK-V3E standalone kit capability
- Comprehensive free software libraries and examples available with the STM32CubeH7 MCU Package
- Supported by wide choice of Integrated Development Environments (IDEs) including IAR[™], Keil[®], GCC-based IDEs



a. Arm is a registered trademark of Arm Limited (or its subsidiaries) in the US and/or elsewhere.

2 Ordering information

To order the Nucleo-144 board corresponding to the target STM32, use the order code given below in [Table 1](#):

Table 1. Ordering information

Order code	Board reference	Target STM32	Differentiating feature
NUCLEO-H745ZI-Q	MB1363	STM32H745ZIT6U	– Ethernet
NUCLEO-H755ZI-Q		STM32H755ZIT6U	– Ethernet – Cryptography
NUCLEO-H7A3ZI-Q		STM32H7A3ZIT6QU	– None

2.1 Product marking

Evaluation tools marked as “ES” or “E” are not yet qualified and therefore not ready to be used as reference designs or in production. Any consequences deriving from such usage will not be at ST charge. In no event, ST will be liable for any customer usage of these engineering sample tools as reference designs or in production.

“E” or “ES” marking examples of location:

- On the targeted STM32H7 that is soldered on the board (For an illustration of STM32H7 marking, refer to the STM32H7 datasheet “Package information” paragraph at the www.st.com website).
- Next to the evaluation tool ordering part number that is stuck or silk-screen printed on the board.

These boards feature a specific STM32H7 device version, which allows the operation of any stack or library. This STM32H7 device shows a ‘U’ marking option at the end of the standard part number and is not available for sales.

2.2 Codification

The meaning of the NUCLEO-XXYYZT-Q codification is explained in [Table 2](#) with an example:

Table 2. Codification explanation

NUCLEO-XXYYZT-Q	Description	Example: NUCLEO-H745ZI-Q
XX	MCU series in STM32 Arm Cortex MCUs	STM32H7 Series
YY	MCU product line in the series	STM32H745
Z	STM32H7 package pin count	144 pins
T	STM32H7 Flash memory size -I for 2 Mbytes	2 Mbytes
-Q	STM32 has internal SMPS function	Internal SMPS

The order code is mentioned on a sticker placed on the top side of the board.

3 Development environment

3.1 Development toolchains

- Arm® Keil®: MDK-ARM^(a)
- IAR™: EWARM^(a)
- GCC-based IDEs

3.2 System requirements

- Windows® OS (7, 8 and 10), Linux® or macOS®^(b)
- USB Type-A to Micro-B cable

3.3 Demonstration software

The demonstration software, included in the STM32Cube package, is preloaded in the STM32H7 Flash memory for easy demonstration of the device peripherals in standalone mode. The latest versions of the demonstration source code and associated documentation can be downloaded from the www.st.com/stm32nucleo web page.

a. On Windows only.

b. macOS® is a trademark of Apple Inc. registered in the U.S. and other countries.

4 Conventions

[Table 3](#) provides the conventions used for the ON and OFF settings in the present document.

Table 3. ON/OFF conventions

Convention	Definition
Jumper JPx ON	Jumper fitted
Jumper JPx OFF	Jumper not fitted
Solder bridge SBx ON	SBx connections closed by solder or 0-ohm resistor
Solder bridge SBx OFF	SBx connections left open

In this document, the references for all information that is common to all sale types, are “STM32H7 Nucleo-144 board” and “STM32H7 Nucleo-144 boards”.

5 Quick start

The STM32H7 Nucleo-144 board is a low-cost and easy-to-use development kit, used to evaluate and start development quickly with an STM32H7 microcontroller in LQFP144 package.

Before installing and using the product, accept the Evaluation Product License Agreement from the www.st.com/epla web page. For more information on the STM32H7 Nucleo-144 and for demonstration software, visit the www.st.com/stm32nucleo web page.

5.1 Getting started

Follow the sequence below to configure the Nucleo-144 board and launch the demonstration application (For components location, refer to [Figure 4](#)):

1. Check the JP2 (5 V) position (Refer to [Section 6.4](#)). Make sure JP4 (IDD) is selected (Refer to [Section 6.8](#)) and make sure JP5 (1.8 V / 3.3 V) is correctly configured (Refer to [Section 6.4.9](#))
2. For the correct identification of the device interfaces from the host PC and before connecting the board, install the Nucleo USB driver available on the www.st.com/stm32nucleo website.
3. Power the board by connecting the STM32H7 Nucleo-144 board to a PC with a USB cable 'Type-A to Micro-B' through the USB connector CN1 on the ST-LINK. As a result, the green LED LD5 (PWR) and LD4 (COM) light up and the red LED LD3 blinks.
4. Press button B1 (Left button).
5. Observe the blinking frequency of the three LEDs LD1 to LD3 changes, by clicking on the button B1.
6. The software demonstration and the several software examples, that allow the user to use the Nucleo features, are available at the www.st.com/stm32nucleo web page.
7. Develop an application, using the available examples.

6 Hardware layout and configuration

The STM32H7 Nucleo-144 board is designed around the STM32H7 microcontrollers in a 144-pin LQFP package.

Figure 3 shows the connections between the STM32H7 and its peripherals: STLINK-V3E, push-buttons, LEDs, USB, Ethernet (Only on NUCLEO-H745ZI-Q and NUCLEO-H755ZI-Q), ST Zio connectors and ST morpho headers.

Figure 4 shows the location of these features on the STM32H7 Nucleo-144 board.

The mechanical dimensions of the board are shown in *Figure 5* and *Figure 6*.

Figure 3. Hardware block diagram

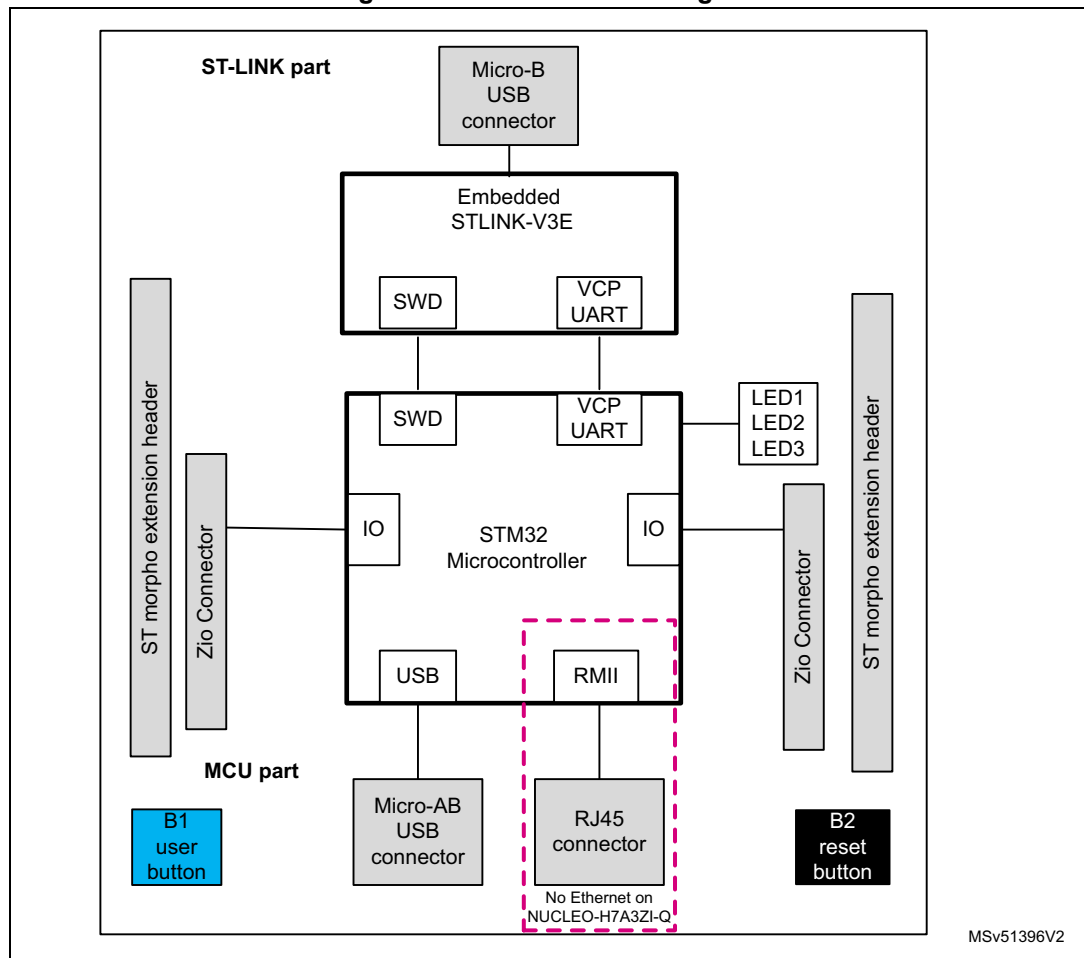

6.1 Nucleo-144 board layout

Figure 4. Nucleo-144 board top layout

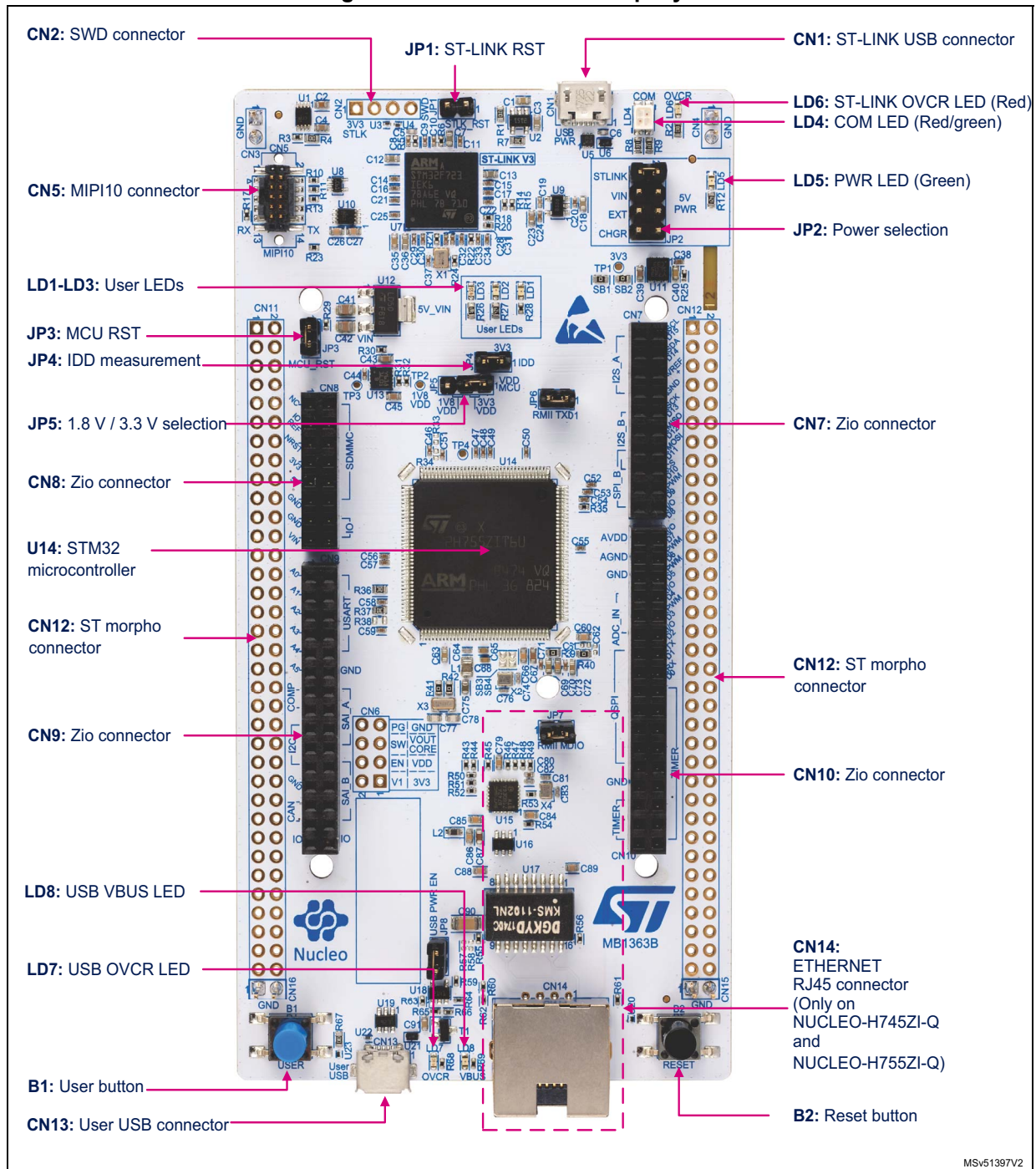

MSv61397V2

6.2 Mechanical drawing

Figure 5. Nucleo-144 board mechanical drawing in millimeter

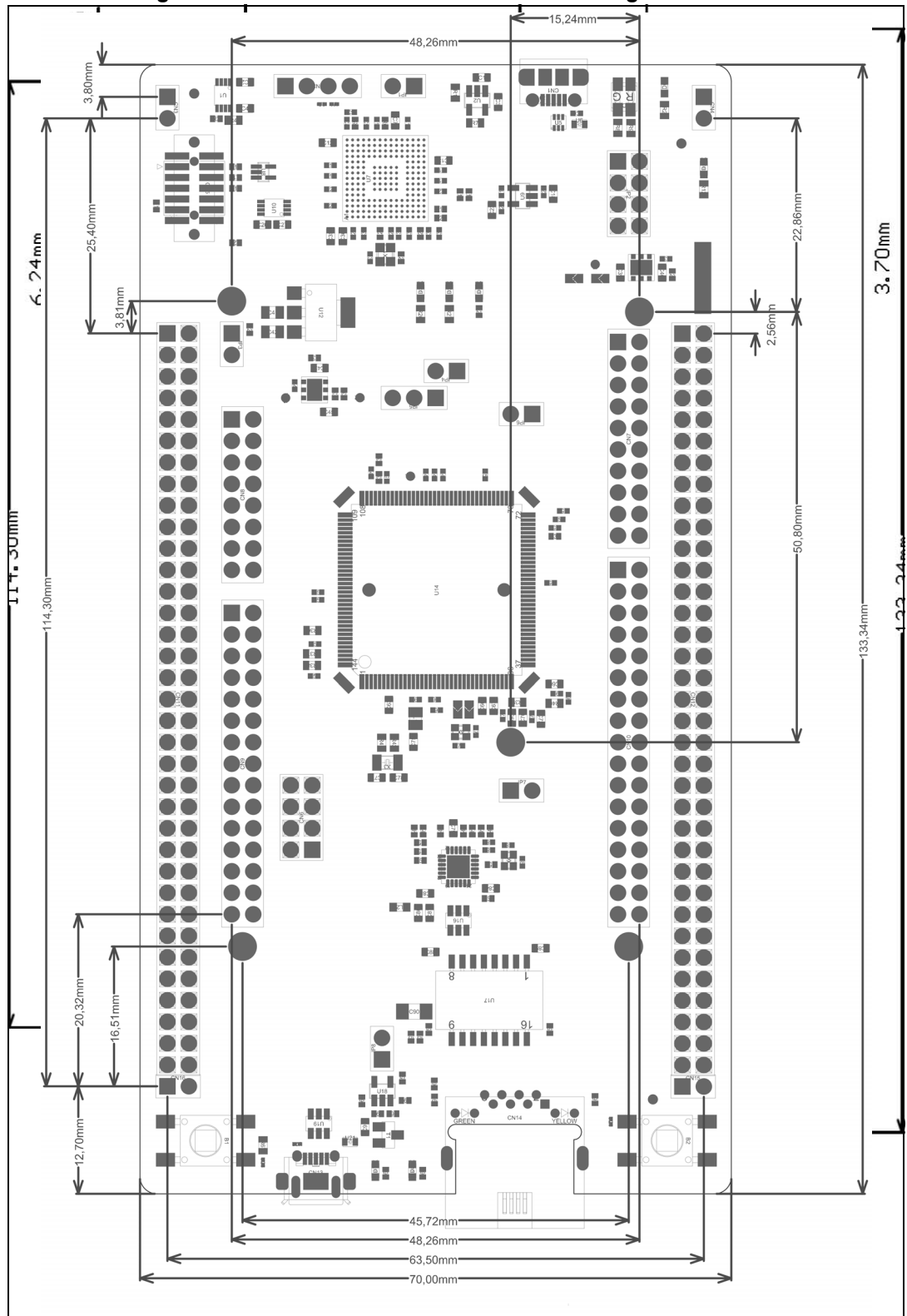
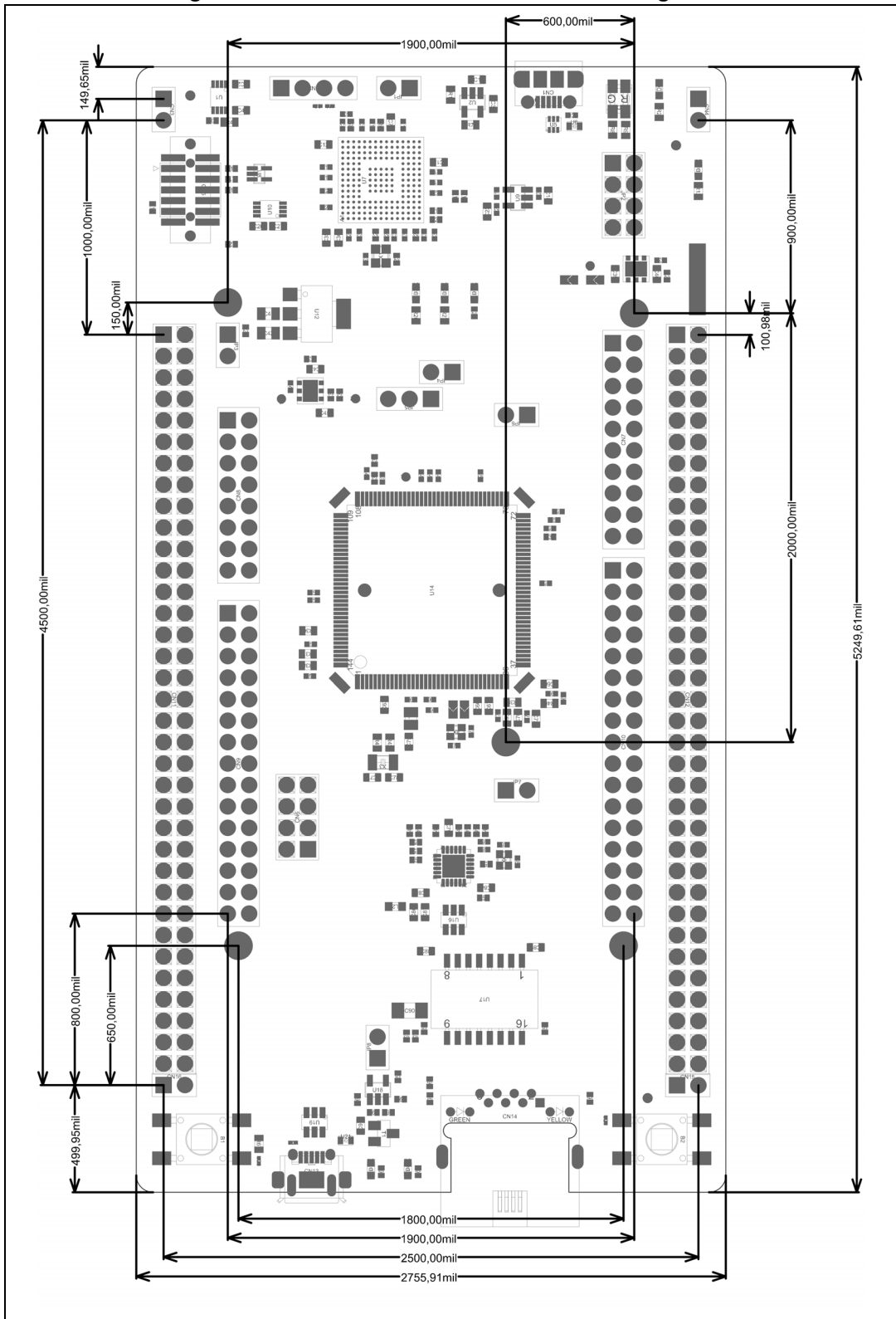

Figure 6. Nucleo-144 board mechanical drawing in mil



6.3 Program and debug the onboard STM32H7 target

There are two different ways to program and debug the onboard STM32H7 MCU.

- Using the embedded STLINK-V3E
- Using an external debug tool

6.3.1 Using the STLINK-V3E to program and debug the onboard STM32H7

Features

The STLINK-V3E programming and debugging tool is integrated into the STM32H7 Nucleo-144 board.

The STLINK-V3E makes the STM32H7 Nucleo-144 board Mbed enabled.

The embedded STLINK-V3E supports:

- 5 V power supplied by USB connector (CN1)
- USB 2.0 high-speed-compatible interface
- JTAG/serial wire debugging (SWD) specific features:
 - 3 V to 3.6 V application voltage on the JTAG/SWD interface and 5 V tolerant inputs
 - JTAG
 - SWD and serial viewer (SWV) communication
- Direct firmware update feature (DFU) (CN2)
- STDC14 (MIPI10) compatible connector (CN5)
- Status COM LED (LD4) which blinks during communication with the PC
- Fault red LED (LD6) alerting on USB overcurrent request
- 5 V/500 mA output power supply capability (U2) with current limitation and LED
- Green LED ON: 5 V enabled (LD5)

How to use

It is very easy to use the STLINK-V3E to program and debug the onboard STM32H7.

1. Verify that the jumper JP2 of Power Supply Sources is correctly set (Refer to [Section 6.4](#)).
2. Connect the board to a PC with a USB cable 'type A to micro-B' through the USB connector CN1.

Note: For more details regarding the STLINK-V3E functionalities, refer to the STLINK-V3E user manual on the www.st.com website

Drivers

Before connecting the product via USB to a PC running on Windows 7 or 8, a driver for the STLINK-V3E must be installed (Not required for Windows 10). It is available on the www.st.com website.

In case the STM32H7 Nucleo-144 board is connected to the PC before installing the driver, the PC device manager may report some Nucleo interfaces as “Unknown”.

To recover from this situation, after installing the dedicated driver, the association of “Unknown” USB devices found on the STM32H7 Nucleo-144 board to this dedicated driver, must be updated in the device manager manually.

Note: It is recommended to proceed using a USB composite device, as shown in [Figure 7](#).

Figure 7. USB composite device

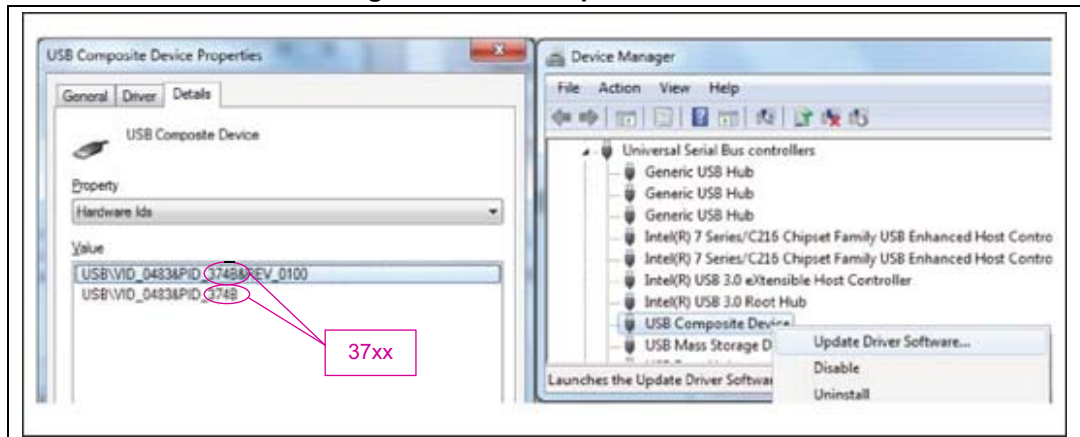

Note: 37xx = 374E for STLINK/V3 without bridges functions
374F for STLINK/V3 with bridges functions

STLINK-V3E firmware upgrade

The STLINK-V3E embeds a firmware upgrade mechanism for an in-situ upgrade through the USB port. As the firmware may evolve during the lifetime of the STLINK-V3E product (For example new functionalities, bug fixes, support for new microcontroller families), it is recommended to keep the STLINK-V3E firmware up to date before starting to use the STM32H7 Nucleo-144 board. The latest version of this firmware is available from the www.st.com website.

6.3.2 Using an external debug tool to program and debug the onboard STM32H7

There are 2 basic ways to support an external Debug tool:

1. Keep the embedded STLINK-V3E running.
Power on the STLINK-V3E at first until the COM LED lights RED. Then the user connects his external debug tool through CN5 MIPI-10 debug connector.
2. Set the embedded STLINK-V3E in high impedance state:
When the user states the jumper JP1 (STLK_RST) ON, the embedded STLINK-V3E is in RESET state and all GPIOs are in high impedance, then the user can connect his external debug tool to the debug connector CN5.

Note: Depending on the design requirement, the embedded STLINK-V3E Hardware could be completely disconnected if that is required early in the project.

Table 4. MIPI-10 debug connector (CN5)

MIPI-10 Pin	STDC14 Pin	CN5	Designation
-	1	NC	Reserved
-	2	NC	Reserved
1	3	T_VCC	Target VCC
2	4	T_SWDIO	Target SWDIO using SWD protocol or Target JTMS (T_JTMS) using JTAG protocol
3	5	GND	Ground
4	6	T_SWCLK	Target SWCLK using SWD protocol or Target JCLK (T_JCLK) using JTAG protocol
5	7	GND	Ground
6	8	T_SWO	Target SWO using SWD protocol or Target JTDO (T_JTMS) using JTAG protocol
7	9	T_JRCLK	Not used by SWD protocol, Target JRCLK (T_JRCLK) using JTAG protocol, only for specific use
8	10	T_JTDI	Not used by SWD protocol, Target JTDI (T_JTDI) using JTAG protocol, only for external tools
9	11	GNDDetect	GND detect for plug indicator, used on SWD and JTAG neither
10	12	T_NRST	Target NRST using SWD protocol or Target JTMS (T_JTMS) using JTAG protocol
-	13	T_VCP_RX	Target RX used for VCP (Must be UART dedicated to the bootloader)
-	14	T_VCP_TX	Target TX used for VCP (Must be UART dedicated to the bootloader)

6.4 Power supply and power selection

The power supply can be provided by five different sources:

- **A host PC connected to CN1 through a USB cable (Default setting)**
- An external 7-11 V power supply connected to CN8 pin 15 or CN11 pin 24
- An external 5 V power supply connected to CN11 pin 6
- An external 5 V USB charger (5V_USB_CHGR) connected to CN1
- An external 3.3 V power supply (3V3) connected to CN8 pin 7 or CN11 pin 16

In case V_{IN} , EXT, CHGR or 3.3 V is used to power the Nucleo-144 board, this power source must comply with the standard EN-60950-1: 2006+A11/2009 and must be Safety Extra Low Voltage (SELV) with limited power capability.

In case the power supply is 3.3 V or a 5 V USB charger on CN1, the ST-LINK is not powered and cannot be used.

6.4.1 Power supply input from STLINK-V3E USB connector (Default setting)

The STM32H7 Nucleo-144 board and shield can be powered from the ST-LINK USB connector CN1 (U5V), by placing a jumper between the pins 1-2 of JP2 STLK (Refer to [Figure 8](#)).

This is the default setting.

Figure 8. Power supply input from ST-LINK USB connector with PC (5 V, 500 mA max)

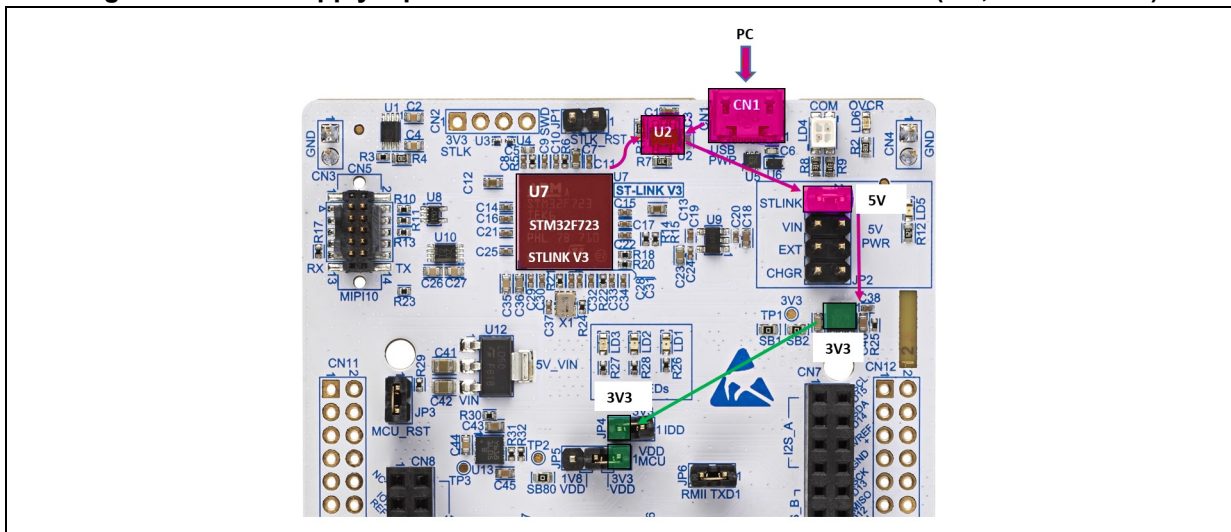

If the USB enumeration succeeds, the 5V_ST_LINK power is enabled, by asserting the PWR_ENn signal from STM32F723IEK6 ‘STLINK V3’ (U7). This pin is connected to a power switch STMP2151STR (U2), which powers the board. The power switch STMP2151STR (U2) features also a current limitation to protect the PC in case of onboard short-circuit. If an overcurrent, more than 500 mA, happens on-board, the red LED LD6 is lit.

Nucleo board and its shield on it can be powered from ST-LINK USB connector CN1, but only the ST-LINK circuit gets power before USB enumeration because the host PC only provides 100 mA to the board at that time.

During the USB enumeration, the Nucleo board asks for the 500 mA power to the host PC.

- If the host is able to provide the required power, the enumeration finishes by a "SetConfiguration" command and then, the power switch STMP2151STR is switched ON, the Green LED LD5 is turned ON, thus Nucleo board and its shield on it can consume 500 mA current, but not more.
- If the host is not able to provide the requested current, the enumeration fails. Therefore, the STMP2151STR power switch (U2) remains OFF and the MCU part including the extension board is not powered. As a consequence, the GREEN LED LD5 remains turned OFF. In this case, it is mandatory to use an external power supply.

6.4.2 External power supply input from V_{IN} (7-11 V, 800 mA max)

When the STM32H7 Nucleo-144 board is power supplied by V_{IN} (Refer to [Table 4](#) and [Figure 9](#)), the jumper configuration must be the following: Jumper JP2 on pin 3-4 VIN.

Table 5. External power sources: V_{IN} (7-11 V)

Input power name	Connector pins	Voltage range	Max current	Limitation
V_{IN}	CN8 pin 15 CN11 pin 24	7 V to 11 V	800 mA	From 7 V to 11 V only and input current capability is linked to input voltage: - 800 mA input current when $V_{IN}=7$ V - 450 mA input current when $7 < V_{IN} < 9$ V - 250 mA input current when $9 < V_{IN} < 11$ V

Figure 9. Power supply input from V_{IN} (7-11 V, 800 mA max)

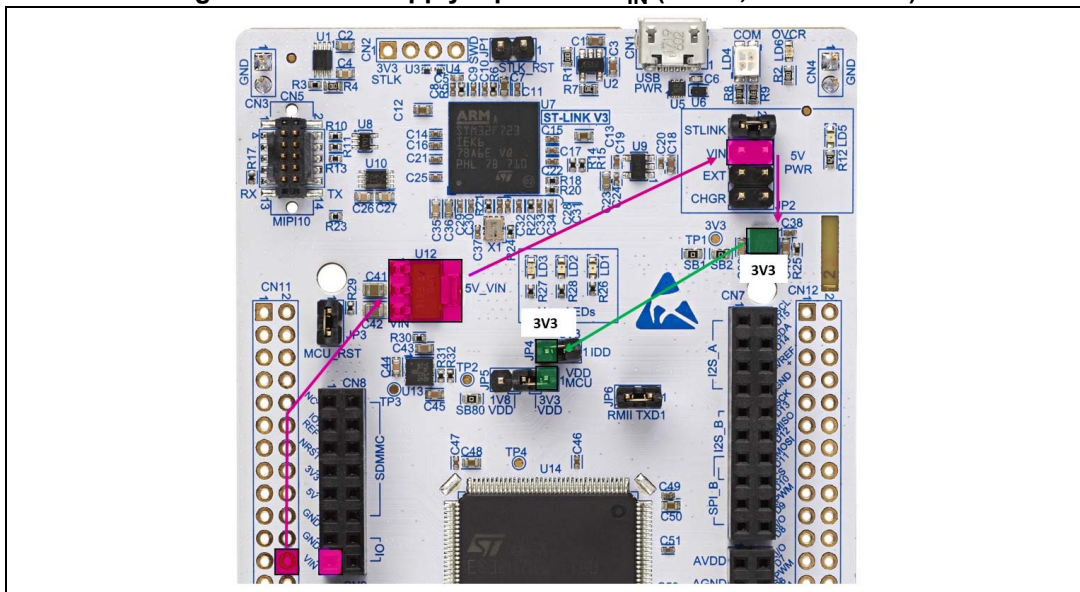

Note: Refer to [Section 6.4.6](#) about debugging when using an external power supply.

6.4.3 External power supply input 5V_EXT (5 V, 500 mA max)

When the STM32H7 Nucleo-144 board is power supplied by EXT (Refer to [Table 6](#) and [Figure 10](#)), the jumper configuration must be the following: Jumper JP2 on pin 5-6 EXT.

Table 6. External power sources: 5V_EXT

Input power name	Connector pins	Voltage range	Max current
EXT	CN11 pin 6	4.75 V to 5.25 V	500 mA

Note: Refer to [6.4.6](#) about debugging when using an external power supply.

Figure 10. Power supply input from 5V_EXT (5 V, 500 mA max)

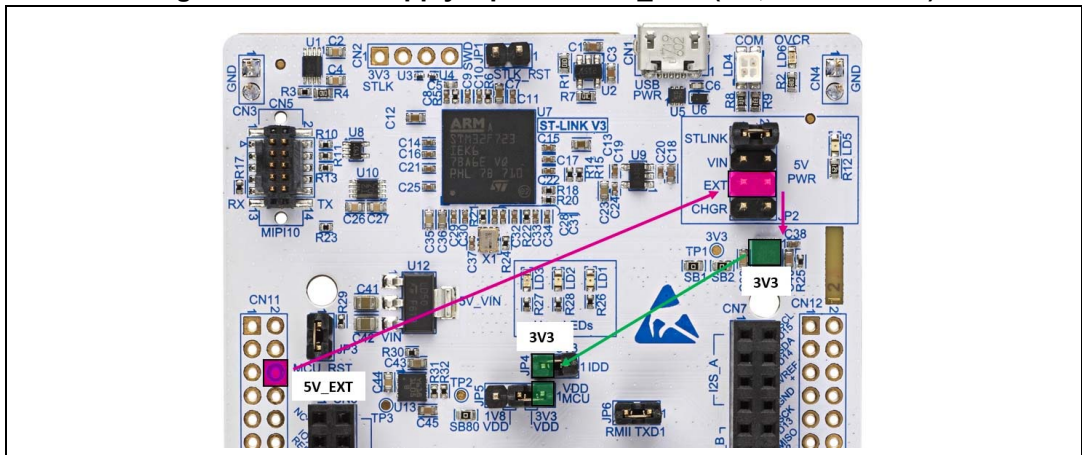

6.4.4 External power supply input from USB CHARGER (5V)

When the STM32H7 Nucleo-144 board is power supplied by a USB charger on CN1 (Refer to [Table 7](#) and [Figure 11](#)), the jumper configuration must be the following: Jumper JP2 on pin 7-8 CHGR.

Table 7. External power sources: CHGR (5 V)

Input power name	Connector pins	Voltage range	Max current
CHGR	CN1	5 V	-

Figure 11. Power supply input from ST-LINK USB connector with a USB charger (5 V)

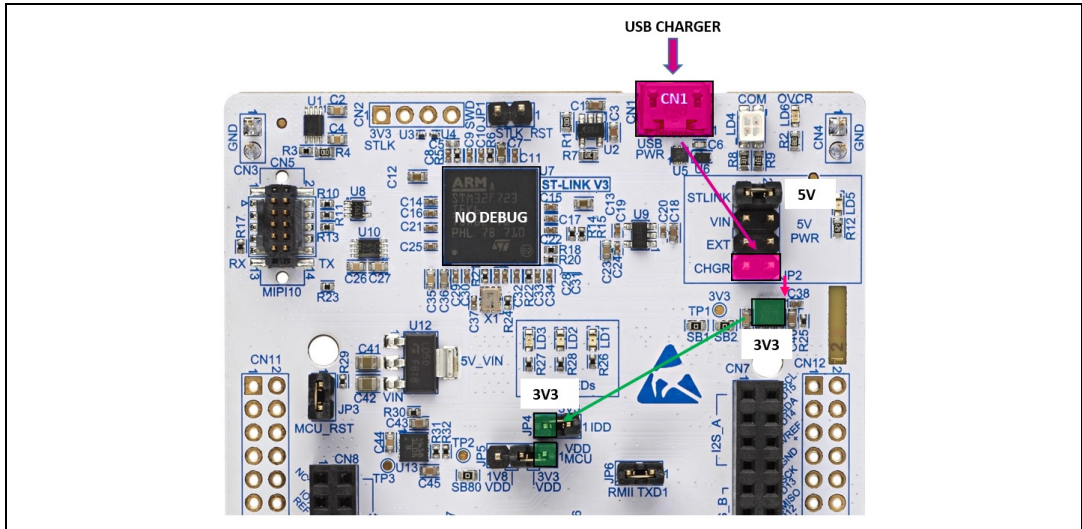

6.4.5 External power supply input from 3V3_EXT (3.3 V)

When the 3.3V is provided by a shield board, it is interesting to use the 3.3 V (CN8 pin 7 or CN11 pin 16) directly as a power input (Refer to [Table 8](#) and [Figure 12](#)). In this case, the programming and debugging features are not available since the ST-LINK is not powered.

Table 8. External power sources: 3V3_EXT (3.3 V)

Input power name	Connector pins	Voltage range	Max current
3V3	CN8 pin 7 CN11 pin 16	3 V to 3.6 V	-

Figure 12. Power supply input from 3V3V_EXT (3.3 V)

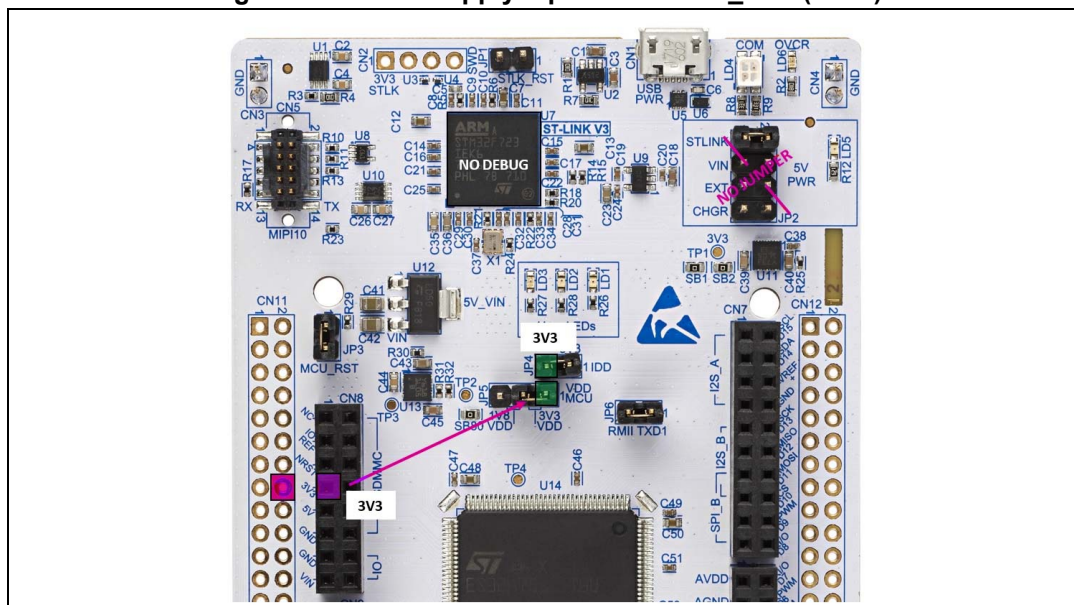

6.4.6 Debugging while using V_{IN} or EXT as an external power supply

When powered by V_{IN} or EXT, it is still possible to use the ST-LINK for programming or debugging only, but it is mandatory to power the board first using V_{IN} or EXT, then to connect the USB cable to the PC. In this way, the enumeration succeeds, thanks to the external power source.

The following power-sequence procedure must be respected:

1. Connect jumper JP2 between pin 5 and pin 6 for EXT or between pin 3 and pin 4 for V_{IN}
2. Connect the external power source to V_{IN} or EXT
3. Power on the external power supply 7 V < V_{IN} < 11 V to V_{IN}, or 5 V for EXT
4. Check that the green LED LD5 is turned ON
5. Connect the PC to the USB connector CN1

If this order is not respected, the board may be powered by USB (U5V) first, then by V_{IN} or EXT as the following risks may be encountered:

1. If more than 300 mA current is needed by the board, the PC may be damaged or the current supplied can be limited by the PC. As a consequence, the board is not powered correctly.
2. 300 mA is requested at enumeration so there is a risk that the request is rejected and the enumeration does not succeed if the PC cannot provide such current. Consequently, the board is not power supplied (LED LD5 remains OFF).

6.4.7 External power supply output

When powered by USB, VIN or EXT, the 5V (CN8 pin 9 or CN11 pin 18) can be used as an output power supply for an ST Zio shield or an extension board. In this case, the maximum current of the power source specified in [Table 9](#)

When the STM32H7 Nucleo-144 board is power supplied by VIN, the jumper configuration must be the following: Jumper JP2 on pin 3-4 VIN.

Table 9. External power sources maximum currents

Input power name	Connector pins	Voltage range	Max current	Limitation
VIN	CN8 pin 15 CN11 pin 24	7 V to 11 V	800 mA	From 7 V to 11 V only and input current capability is linked to input voltage: – 800 mA input current when VIN=7 V – 450 mA input current when 7 V<VIN<9 V – 250 mA input current when 9 V<VIN<11 V
EXT	CN11 pin 6	4.75 V to 5.25 V	500 mA	-
CHGR	CN1	5 V	-	-
3.3V	CN8 pin 7 CN11 pin 16	3 V to 3.6 V	-	-

The 3.3 V (CN8 pin 7 or CN11 pin 16) can be used also as a power supply output. The current is limited by the maximum current capability of the regulator U11 (1300 mA max).

6.4.8 Internal SMPS / LDO Configuration

Different internal SMPS / LDO configurations are supported. Refer to [Table 10](#) for the solder bridge configuration corresponding to each of them.

Table 10. SMPS / LDO configuration

	Supply config 1: Internal LDO only	Supply config 2: Internal SMPS only (Default)	Supply config 3: Internal SMPS and LDO cascaded	Supply config 4: Bypass
SMPS	OFF	ON	ON	OFF
LDO	ON	OFF	ON	OFF
SB25	X	-	-	-
R33	X	-	-	X
SB74	X	-	-	X
C58	2.2 uF	100 nF	2.2 uF	100 nF
C54	2.2 uF	100 nF	2.2 uF	100 nF
SB92	-	X	X	-
SB79	-	X	X	-
SB75	-	X	-	X
SB76	-	X	X	X

Table 10. SMPS / LDO configuration (continued)

	Supply config 1: Internal LDO only	Supply config 2: Internal SMPS only (Default)	Supply config 3: Internal SMPS and LDO cascaded	Supply config 4: Bypass
R35	-	X	-	-
R34	-	-	X	-
SB97	-	-	-	X
SB95	-	-	-	X

Figure 13. Supply configuration 1: Internal LDO only

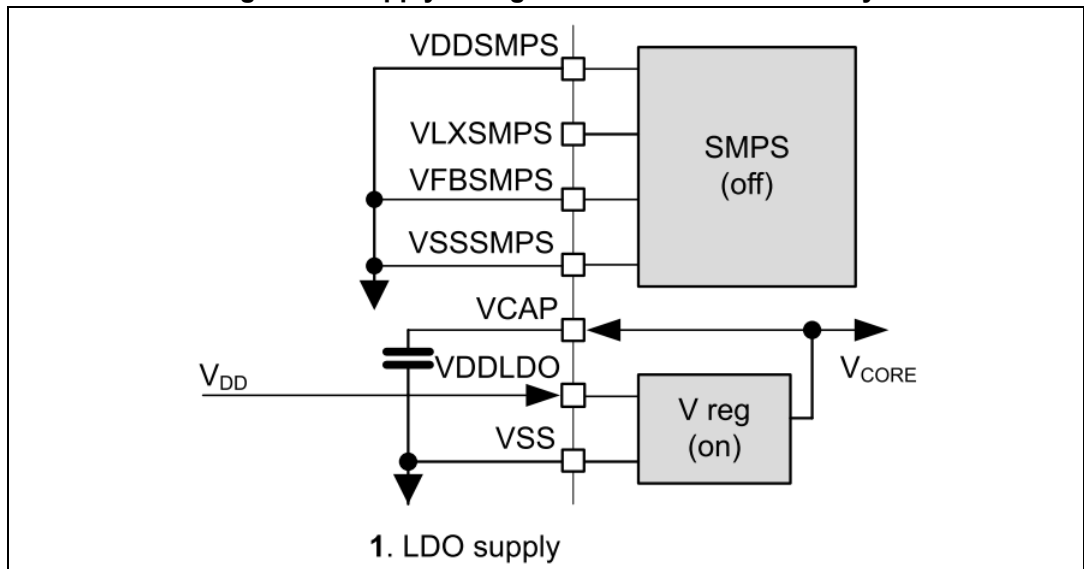

Figure 14. Supply configuration 2: Internal SMPS only (Default)

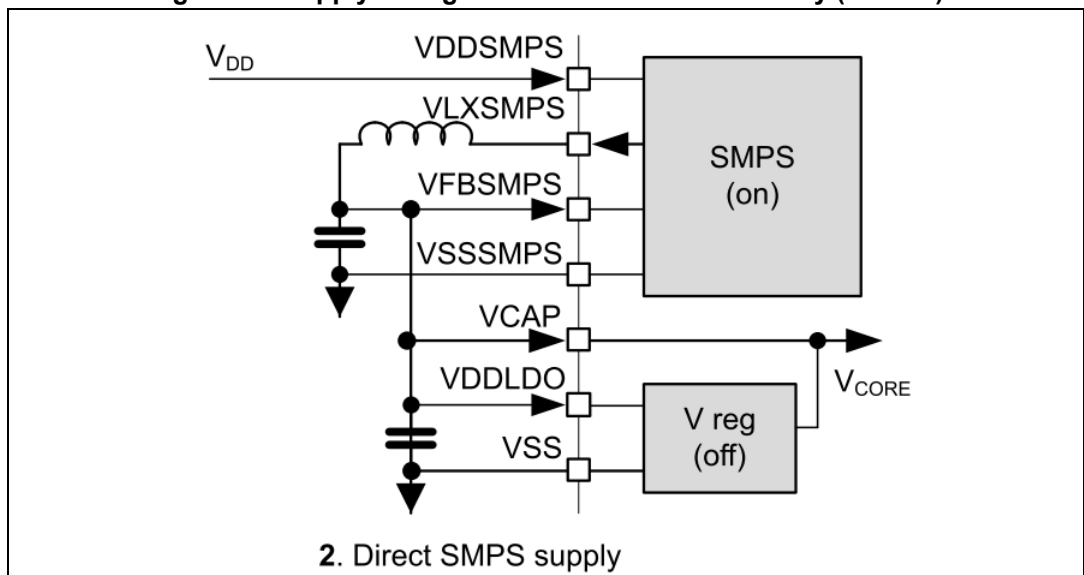

Figure 15. Supply configuration 3: Internal SMPS and LDO cascaded

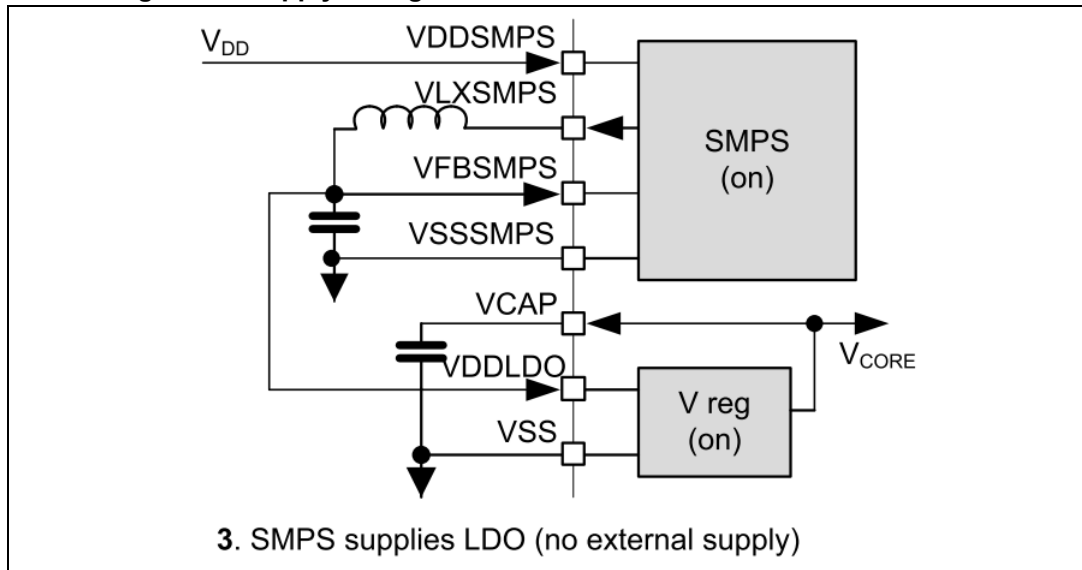
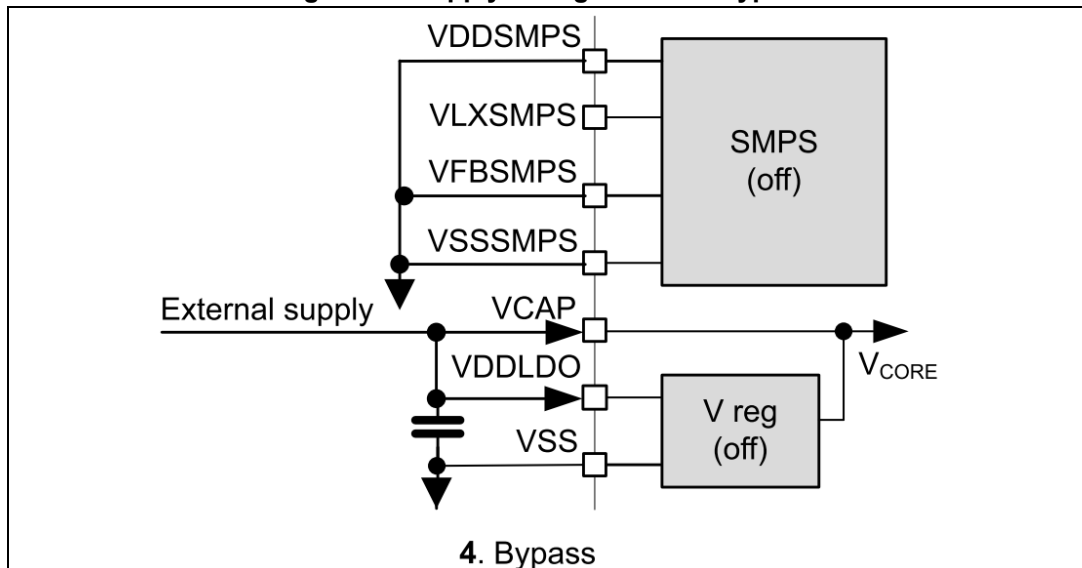

Figure 16. Supply configuration 4: Bypass



Warning: Board SMPS/LDO firmware power configuration must match with the hardware configuration. If not, the user faces a deadlock: after the reset, STLINK can't connect the target anymore.

The firmware power configuration corresponds with the following in the main.c, in the function SystemClock_Config:
 - In the case of "Direct SMPS" hardware configuration (Default): HAL_PWREx_ConfigSupply (PWR_DIRECT_SMPS_SUPPLY);

- In the case of “LDO” hardware configuration:
HAL_PWREx_ConfigSupply (PWR_LDO_SUPPLY);

If a deadlock is faced due to a mismatch between the hardware board setting and the firmware setting (LDO/SMPS), the user can recover the board by doing the following:

- Power off the board
- Connect CN11 ‘BT0’ pin (BOOT0) to VDD using a wire
- This changes the BOOT0 pin to HIGH instead of LOW and thus the device boot address is changed to boot address 1 making the bootloader starting in System memory, instead of starting the firmware in the user Flash (Firmware that is setting a wrong LDO/SMPS configuration)
- Power on the board and connect using STM32CubeProgrammer
- Erase the user Flash
- Power off the board and remove the wire between BOOT0 and VDD
- The recovery is now completed and the board can be used normally.

6.4.9 JP5: 1.8 V / 3.3 V selection

JP5, labeled "VDD_MCU" is used to select the VDD supply for the MCU:

- Jumper JP5 pin 1-2: VDD_MCU = 3.3 V (Default configuration)
- Jumper JP5 pin 2-3: VDD_MCU = 1.8 V

6.5 External SMPS selection

The user can connect an external SMPS to the CN6 footprint (For example ST1PS02D1QTR).

CN6 pin-out is described in [Table 11](#).

Table 11. External SMPS selection

CN6 pin	Pin name	Function	Configuration when using an external module connected to CN6
CN6 Pin 1	3V3_VDD	3.3V VDD supply for MCU	-
CN6 Pin 2	SMPS_V1 (PG8)	External SMPS output voltage selection “D1” ⁽¹⁾	SB34 ON / SB31 OFF
CN6 pin 3	VOUVDD	External 3.3V VDD supply for MCU	-
CN6 Pin 4	SMPS_EN (PG9)	External SMPS Enable “EN” ⁽¹⁾	SB35 ON / SB41 OFF

Table 11. External SMPS selection (continued)

CN6 pin	Pin name	Function	Configuration when using an external module connected to CN6
CN6 pin 5	1V2_VOUTCORE	External SMPS 1.2V or external power supply providing 1.2V for MCU VCORE (VCAP pins)	-
CN6 Pin 6	SMPS_SW (PG10)	External SMPS Enable for the auxiliary output voltage "AUX" ⁽¹⁾	SB33 ON / SB30 OFF
CN6 pin 7	GND	GND	-
CN6 Pin 8	SMPS_PG (PG12)	External SMPS Power good "PGOOD" ⁽¹⁾	SB42 ON / SB45 OFF

1. Refer to the ST1PS02D1QTR datasheet for more information about possible use cases.

6.6 LEDs

User LD1: a green user LED is connected to the STM32H7 I/O PB0 (SB65 OFF and SB54 ON) or PA5 (SB65 ON and SB54 OFF) corresponding to the ST Zio D13.

User LD2: a yellow user LED is connected to PE1.

User LD3: a red user LED is connected to PB14.

Caution: LD3 cannot be used if Zio D65 is used (In this case, remove R75).

These user LEDs are on when the I/O is HIGH value, and are off when the I/O is LOW.

LD4 COM: the tricolor LED LD4, green, orange, red, provides information about ST-LINK communication status. LD4 default color is red. LD4 turns to green to indicate that communication is in progress between the PC and the STLINK-V3E, with the following setup:

- Slow blinking red/off: at power-on before USB initialization
- Fast blinking red/off: after the first correct communication between PC and STLINK-V3E (Enumeration)
- Red LED on: when the initialization between the PC and STLINK-V3E is complete
- Green LED on: after a successful target communication initialization
- Blinking red/green: during communication with the target
- Green on: communication finished and successful
- Orange on: communication failure

LD5 PWR: the green LED indicates that the STM32H7 part is powered and +5 V power is available on CN8 pin 9 and CN11 pin 18.

LD6 USB power fault: LD5 indicates that the board power consumption on USB exceeds 500 mA, consequently the user must power the board using an external power supply.

LD7 and LD8 USB FS: refer to [Section 6.11: USB OTG FS or device](#).

6.7 Push-buttons

B1 user (Blue button): the user button is connected to the I/O PC13 by default (Tamper support, SB82 ON and SB81 OFF) or PA0 (Wakeup support, SB81 ON and SB82 OFF) of the STM32H7 microcontroller.

B2 reset (Black button): this push-button is connected to NRST and is used to reset the STM32H7 microcontroller.

6.8 JP4 (IDD)

Jumper JP4, labeled IDD, is used to measure the STM32H7 microcontroller consumption by removing the jumper and by connecting an ammeter:

- JP4 ON: STM32H7 is powered (Default position),
- JP4 OFF: an ammeter must be connected to measure the STM32H7 current. If there is no ammeter, the STM32H7 is not powered.

As VDD is supplying level shifters U1 and U10, for very low power measurement, it is recommended to set a pull-up, or pull-down, via software for PA13, PB3, and PD8 pins.

Warning: On MB1363 Rev.C, VDD_MCU is also supplying Ethernet PHY (U15) and debug voltage translation (U1 and U10).

On MB1363 Rev.C: If needed, for low power measurement (For example standby mode), in order to measure only MCU (U7) power consumption, the user must remove the following components: R4, R43, R44, R45, R46, R47, R48, R49, R50, R51, R52, R53, R59, R64, U1, U10, U15, and SB72.

After removing these components, it becomes impossible to use Ethernet, and 1.8 V debug with ST-LINK.

6.9 OSC clock

6.9.1 OSC clock supply

There are four ways to configure the pins corresponding to the external high-speed clock (HSE):

- MCO from ST-LINK (Default): MCO output of ST-LINK is used as an input clock. This frequency cannot be changed, it is fixed at 8 MHz and connected to the PH0-OSC_IN of the STM32H7 microcontroller. The configuration must be:
 - SB71 OFF
 - SB72 ON
 - SB3 and SB4 OFF
- HSE onboard oscillator from X2 crystal: for typical frequencies and its capacitors and resistors, refer to the STM32H7 microcontroller datasheet and to the application note *Oscillator design guide for STM8AF/AL/S and STM32 microcontrollers* AN2867 for the oscillator design guide. The X2 crystal has the following characteristics: 25 MHz, 6 pF,

20 ppm. It is recommended to use NX2016SA-25MHz-EXS00A-CS11321 manufactured by NDK. The configuration must be:

- SB71 and SB90 OFF
- SB3 and SB4 ON
- C74 and C76 soldered with 5.1 pF capacitors
- SB72 OFF

Oscillator from external PH0: from an external oscillator through the pin 29 of the CN11 connector. The configuration must be:

- SB71 ON
- SB72 OFF
- SB3 and SB4 removed
- HSE not used: PH0 and PH1 are used as GPIOs instead of clocks. The configuration must be:
 - SB71 and SB90 ON
 - SB72 (MCO) OFF
 - SB3 and SB4 removed

6.9.2 OSC 32 KHz

There are three ways to configure the pins corresponding to the low-speed clock (LSE):

- **Onboard oscillator (Default):** X3 crystal. Refer to the application note *Oscillator design guide for STM8AF/AL/S and STM32 microcontrollers AN2867* for oscillator design guide for STM32H7 microcontrollers. It is recommended to use NX3215SA-32.768KHZ EXS00A-MU00525 (32.768 kHz, 6 pf load capacitance, 20 ppm) from NDK.
- **Oscillator from external PC14:** from external oscillator through the pin 25 of CN11 connector. The configuration must be:
 - SB66 and SB67 ON
 - R41 and R42 removed
- **LSE not used:** PC14 and PC15 are used as GPIOs instead of low-speed clocks. The configuration must be:
 - SB66 and SB67 ON
 - R41 and R42 removed

6.10 USART communication

The USART3 interface available on PD8 and PD9 of the STM32H7 can be connected either to ST-LINK or to the ST morpho connector. The choice is changed by setting the related solder bridges. By default, the USART3 communication between the target STM32H7 and the STLINK is enabled, to support the Virtual COM port for the Mbed (SB16 and SB17 ON).

Table 12. USART3 pins

Pin name	Function	Virtual COM port (Default configuration)	ARDUINO® D0 and D1	ST morpho connection
PD8	USART3 TX	SB103 OFF, SB16 ON and SB15 OFF	SB103 OFF, SB16 OFF and SB15 ON	SB103 ON , SB16 OFF, SB15 OFF
PD9	USART3 RX	SB104 OFF, SB17 ON and SB94 OFF	SB104 OFF, SB17 OFF and SB94 ON	SB104 ON , SB17 OFF and SB94 OFF

6.11 USB OTG FS or device

The STM32H7 Nucleo-144 board supports USB OTG or device-full-speed communication via a USB Micro-AB connector (CN13) and USB power switch (U18) connected to V_{BUS} .

Warning: **USB Micro-AB connector (CN13) cannot power the Nucleo-144 board. To avoid damaging the STM32, it is mandatory to power the Nucleo-144 before connecting a USB cable on CN13. Otherwise, there is a risk of current injection on STM32H7 I/Os.**

A green LED LD8 lights in one of these cases:

- Power switch (U18) is ON and the STM32H7 Nucleo-144 board works as a USB host.
- V_{BUS} is powered by another USB host when the STM32H7 Nucleo-144 board works as a USB device.

The red LED LD7 lights if overcurrent occurs when 5 V is enabled on V_{BUS} in USB host mode.

Note: *1. It is recommended to power the Nucleo-144 board by an external power supply when using USB OTG or host function.*

Table 13. USB pin configuration

Pin name	Function	Configuration when using USB connector ⁽¹⁾	Configuration when using ST morpho connector	Remark
PA8	USB SOF	-	-	Test point TP4
PA9	USB VBUS	SB21 ON	SB21 OFF	-
PA10	USB ID	SB29 ON	SB29 OFF	-
PA11	USB DM	SB26 ON	SB26 OFF	-
PA12	USB DP	SB27 ON	SB27 OFF	-
PD10	USB FS PWR EN	NUCLEO-H745ZI-Q / NUCLEO-H755ZI-Q: JP8 ON NUCLEO-H7A3ZI-Q: JP8 OFF	NUCLEO-H745ZI-Q / NUCLEO-H755ZI-Q: JP8 OFF NUCLEO-H7A3ZI-Q: JP8 OFF	-

Table 13. USB pin configuration (continued)

Pin name	Function	Configuration when using USB connector ⁽¹⁾	Configuration when using ST morpho connector	Remark
PF10	USB FS PWR EN	NUCLEO-H745ZI-Q / NUCLEO-H755ZI-Q: SB91 OFF NUCLEO-H7A3ZI-Q: SB91 ON	NUCLEO-H745ZI-Q / H755ZI-Q: SB91 OFF NUCLEO-H7A3ZI-Q: SB91 OFF	-
PG7	USB FS OVCR	SB100 ON	SB100 OFF	-

1. The default SBx / JPx state is shown in bold.

ESD protection part USBLC6-2SC6 is implemented on USB port because all USB pins on STM32H7 are dedicated to USB port only on the STM32H7 Nucleo-144 board. USB pin ID is not used.

6.12 Ethernet (With NUCLEO-H745ZI-Q and NUCLEO-H755ZI-Q)

The STM32H7 Nucleo-144 board supports 10M/100M Ethernet communication by a PHY LAN8742A-CZ-TR (U15) and RJ45 connector (CN14). Ethernet PHY is connected to the STM32H7 microcontroller via the RMII interface. 50 MHz clock for the STM32H7 microcontroller is generated by the PHY RMII_REF_CLK.

Note: 1. NUCLEO-H7A3ZI-Q does not support the Ethernet function.

2. JP6 and JP7 must be ON when using Ethernet.

3. On MB1363 Rev.C: Ethernet PHY LAN8742A must be set in power-down mode (In this mode Ethernet PHY ref clock turns off) to achieve the expected low-power mode current. This is done by configuring Ethernet PHY LAN8742A Basic Control Register, at address 0x00, bit 11 (Power down) to '1'. SB13 can also be removed to get the same effect.

Table 14. Ethernet pin configuration

Pin name	Function	Conflict with ST Zio connector signal	Configuration when using Ethernet ⁽¹⁾	Configuration when using ST Zio or ST morpho connector
PA1	RMII Ref Clock	-	NUCLEO-H745ZI-Q / NUCLEO-H755ZI-Q: SB80 ON	SB80 OFF
PA2	RMII MDIO	A8	NUCLEO-H745ZI-Q / NUCLEO-H755ZI-Q: JP7 ON	JP7 OFF
PC1	RMII MDC	-	NUCLEO-H745ZI-Q / NUCLEO-H755ZI-Q: SB84 ON	SB84 OFF
PA7	RMII RX Data Valid	-	NUCLEO-H745ZI-Q / NUCLEO-H755ZI-Q: SB52 ON	SB52 OFF
PC4	RMII RXD0	-	NUCLEO-H745ZI-Q / NUCLEO-H755ZI-Q: SB63 ON	SB63 OFF
PC5	RMII RXD1	-	NUCLEO-H745ZI-Q / NUCLEO-H755ZI-Q: SB48 ON	SB48 OFF

Table 14. Ethernet pin configuration (continued)

Pin name	Function	Conflict with ST Zio connector signal	Configuration when using Ethernet ⁽¹⁾	Configuration when using ST Zio or ST morpho connector
PG11	RMII TX Enable	-	NUCLEO-H745ZI-Q / NUCLEO-H755ZI-Q: SB36 ON	SB36 OFF
PG13	RXII TXD0	-	NUCLEO-H745ZI-Q / NUCLEO-H755ZI-Q: SB46 ON	SB46 OFF
PB13	RMII TXD1	D18	NUCLEO-H745ZI-Q / NUCLEO-H755ZI-Q: JP6 ON, SB8 OFF	JP6 OFF, SB8 ON

1. The default SBx state is shown in bold.

6.13 Motor control

In order to be compatible with X-NUCLEO-IHM09M1, X-NUCLEO-IHM07M1 (L6230) and X-NUCLEO-IHM08M1 (STL220N6F7) motor-control shields, the user must fit CN11 and CN12 (Samtec TSW-135-07-x-D), and set solder bridges according to [Table 15](#).

Table 15. Motor-control shield configuration

Pin name	Function	Configuration when using ST morpho connector for motor control ⁽¹⁾
PE6	MORPHO RIGHT 14 (BKIN2)	SB10 ON / SB22 OFF
PE15	MORPHO RIGHT 28 (BKIN1)	SB38 ON / SB37 OFF
PA4	MORPHO RIGHT 29 (DAC)	SB77 ON / SB59 OFF
PE8	MORPHO RIGHT 30 (TIM1_CH1N)	SB47 ON / SB43 OFF
PA1	RMII reference clock	SB80 OFF
PC1	RMII MDC	SB84 OFF

1. The default SBx state is shown in bold.

6.14 Solder bridges

Table 16. Solder bridges

Bridge	State ⁽¹⁾	Description
SB1 (3V3_PER) (Only on MB1363 Rev.C)	ON	Peripheral power 3V3_PER is connected to 3.3V.
	OFF	Peripheral power 3V3_PER is not connected.
SB2 (3.3V)	ON	Output of voltage regulator ST1L05CPU33R is connected to 3.3V.
	OFF	Output of voltage regulator ST1L05CPU33R is not connected.

Table 16. Solder bridges (continued)

Bridge	State ⁽¹⁾	Description
SB103, SB104 (GPIO)	ON	PD8 and PD9 on STM32H7 are connected to ST morpho connectors CN11 and CN12. If these pins are used on ST morpho connectors, SB16, SB17, SB15 and SB94 must be OFF.
	OFF	PD8 and PD9 on STM32H7 are disconnected from ST morpho connectors CN11 and CN12.
SB16, SB17, SB12, SB64 (ST-LINK-USART)	ON, ON, OFF, OFF	PA2 and PA3 on ST-LINK STM32F723IEK6 are connected to PD8 and PD9 to enable Virtual COM port for Mbed support. Thus PD8 and PD9 on ST morpho connectors cannot be used.
	OFF, OFF, ON, ON	PA2 and PA3 on ST-LINK STM32F723IEK6 are connected to PB6 and PB7 to enable Virtual COM port for Mbed support. Thus PB6 and PB7 on ST morpho connectors cannot be used.
	OFF, OFF, OFF, OFF	PB6, PB7, PA2, and PA3 on ST-LINK STM32F723IEK6 are disconnected from PD8 and PD9 on STM32H7.
SB11, SB96 , SB15, SB94 (ARDUINO [®] USART)	ON, ON, OFF, OFF	ARD D1 (USART TX) and ARD D0 (USART RX) are connected to PB6 and PB7. Thus PB6 and PB7 on ST morpho connectors cannot be used.
	OFF, OFF, ON, ON	ARD D1 (USART TX) and ARD D0 (USART RX) are connected to PD8 and PD9. Thus PD8 and PD9 on ST morpho connectors cannot be used.
	OFF, OFF, OFF, OFF	ARD D1 (USART TX) and ARD D0 (USART RX) are disconnected from PB6, PB7, PD8, and PD9 on STM32H7.
R40 (VDDA)	ON	VDDA and VREF+ on STM32H7 is connected to VDD.
	OFF	VDDA and VREF+ on STM32H7 is not connected to VDD and can be provided from pin 6 of CN7 (Used for external VREF+ provided by ARDUINO [®] shield).
JP1 (STLINK NRST)	OFF	No incidence on ST-LINK STM32F723IEK6 NRST signal.
	ON	ST-LINK STM32F723IEK6 NRST signal is connected to GND (ST-LINK reset to reduce power consumption).
SB49, SB50 (SWO)	OFF, ON	SWO signal of the STM32H7 (PB3) is connected to ST-LINK SWO input.
	OFF, OFF	SWO signal of STM32H7 is not connected.
JP3 (T_NRST)	ON	Board RESET signal (NRST) is connected to ST-LINK reset control I/O (T_NRST).
	OFF	Board RESET signal (NRST) is not connected to ST-LINK reset control I/O (T_NRST).
SB24, SB13, SB14 (IOREF)	OFF, OFF, ON	IOREF is connected to VDD_MCU
	OFF, ON, OFF	IOREF can be connected to 3V3_PER only on Rev.C
	ON, OFF, OFF	IOREF is connected to 3V3
SB20 (SDMMC_D0), SB9 (SDMMC_D1)	ON	These pins are connected to ST morpho connector CN12.
	OFF	These pins are disconnected from ST morpho connector CN12 to avoid stub of SDMMC data signals on PCB.

Table 16. Solder bridges (continued)

Bridge	State ⁽¹⁾	Description
SB54, SB65 (LD1-LED)	ON, OFF	Green user LED LD1 is connected to PB0.
	OFF, ON	Green user LED LD1 is connected to D13 of ARDUINO® signal (PA5).
	OFF, OFF	Green user LED LD1 is not connected.
	ON, ON	Forbidden
R74 (LD2-LED)	ON	Yellow user LED LD2 is connected to PB7.
	OFF	Yellow user LED LD2 is not connected.
R75 (LD3-LED)	ON	Red user LED LD3 is connected to PB14.
	OFF	Red user LED LD3 is not connected.
SB56, SB57 (D11)	NUCLEO-H745ZI-Q / NUCLEO-H755ZI-Q: OFF, ON	NUCLEO-H745ZI-Q / NUCLEO-H755ZI-Q: D11 (Pin 14 of CN7) is connected to STM32H7 PB5 (SPI_A_MOSI/TIM_D_PWM2).
	NUCLEO-H7A3ZI-Q: ON, OFF	NUCLEO-H7A3ZI-Q: D11 (Pin 14 of CN7) is connected to STM32 PA7 (SPI_A_MOSI/TIM_E_PWM1).
SB66, SB67 (X2 crystal)	OFF	PC14 and PC15 are not connected to ST morpho connector CN11. (X3 used to generate a 32 KHz clock).
	ON	PC14 and PC15 are connected to ST morpho connector CN11. (R41 and R42 must be removed).
SB71 (PH0), SB90 (PH1) (Main clock)	OFF, ON	PH0 is not connected to ST morpho PH1 is connected to the ST morpho connector CN11 (MCO is used as the main clock for STM32H7 on PH0).
	OFF, OFF	PH0 and PH1 are not connected to the ST morpho connector CN11.
	ON, ON	PH0 and PH1 are connected to the ST morpho connector CN11. SB3, SB4, and SB72 must be removed.
SB72 (MCO)	ON	MCO of ST-LINK (STM32F723IEK6) is connected to PF0/PH0 of STM32H7.
	OFF	MCO of ST-LINK (STM32F723IEK6) is not connected to PF0/PH0 of STM32H7.
SB3, SB4 (External 25 MHz crystal)	OFF	PH0 and PH1 are not connected to external 25 MHz crystal X2.
	ON	PH0 and PH1 are connected to external 25 MHz crystal X2.
SB83 (VBAT)	ON	VBAT pin of STM32H7 is connected to VDD_MCU.
	OFF	VBAT pin of STM32H7 is not connected to VDD_MCU.
SB82, SB81 (B1-USER)	ON, OFF	B1 push-button is connected to PC13.
	OFF, ON	B1 push-button is connected to PA0 (Set SB82 OFF if the ST Zio connector is used).
	OFF, OFF	B1 push-button is not connected.
SB89 (PA0)	ON	PA0 is connected to the ST Zio connector (Pin 29 of CN10)
	OFF	PA0 is not connected to ST Zio connector (Pin 29 of CN10)

Table 16. Solder bridges (continued)

Bridge	State ⁽¹⁾	Description
SB69,SB40 (ADC on A4 and A5)	ON, ON, OFF, OFF	PC2, PF11 (ADC) are connected to A4 and A5 (Pins 9 and 11) on the ST Zio connector CN9.
SB62, SB39 (I ² C on A4 and A5)	OFF, OFF, ON, ON	PB9 and PB8 (I ² C) are connected to A4 and A5 (Pins 9 and 11) on the ST Zio connector CN9.
SB73 , SB70 (A6)	ON, OFF	PF6 connected to Zio A6 (NUCLEO-H745ZI-Q / NUCLEO-H755ZI-Q)
	OFF, ON	PC1 connected to Zio A6 (NUCLEO-H7A3ZI-Q)
SB93 , SB58 (A7)	ON, OFF	PF10 connected to Zio A7 (NUCLEO-H745ZI-Q / NUCLEO-H755ZI-Q)
	OFF, ON	PC5 connected to Zio A7 (NUCLEO-H7A3ZI-Q)
SB78 (A8)	ON	PA2 connected to Zio A8 (NUCLEO-H7A3ZI-Q)
	OFF	PA2 disconnected from Zio A8 (H745)
RMII signals SB80 (PA1), SB84 (PC1), JP7 (PA2), SB63 (PC4), SB48 (PC5), SB46 (PG13), SB36 (PG11)	ON	These pins are used as RMII signals and connected to Ethernet PHY. These ports must not be used on ST morpho or ST Zio connectors.
	OFF ⁽²⁾	1.NUCLEO-H745ZI-Q / NUCLEO-H755ZI-Q: these pins are used as GPIOs on ST morpho connectors and not connected to Ethernet PHY. 2.NUCLEO-H7A3ZI-Q: no Ethernet
RMII signals SB98 (Ethernet nRST)	ON	NRST of STM32H7 is connected to Ethernet PHY (U15).
	OFF ⁽²⁾	NRST of STM32H7 is not connected to Ethernet PHY (U15).
SB26 (PA12), SB27 (PA11)	ON	These pins are used as D+ and D- on USB connector CN13.
	OFF	These pins are used as GPIOs on ST morpho connectors.

1. The default SBx state is shown in bold.

2. No default configuration for RMII signals.

All the other solder bridges present on the STM32H7 Nucleo-144 board are used to configure several I/Os and power supply pins for compatibility of features and pinout with the supported target STM32H7.

The STM32H7 Nucleo-144 board is delivered with the solder bridges configured, according to the supported target STM32H7.

6.15 Extension connectors

For each STM32H7 Nucleo-144 board, the following figures show the signals connected by default to the ST Zio connectors (CN7, CN8, CN9, and CN10), including the support for ARDUINO® Uno V3.

Figure 17. NUCLEO-H745ZI-Q and NUCLEO-H755ZI-Q extension connectors

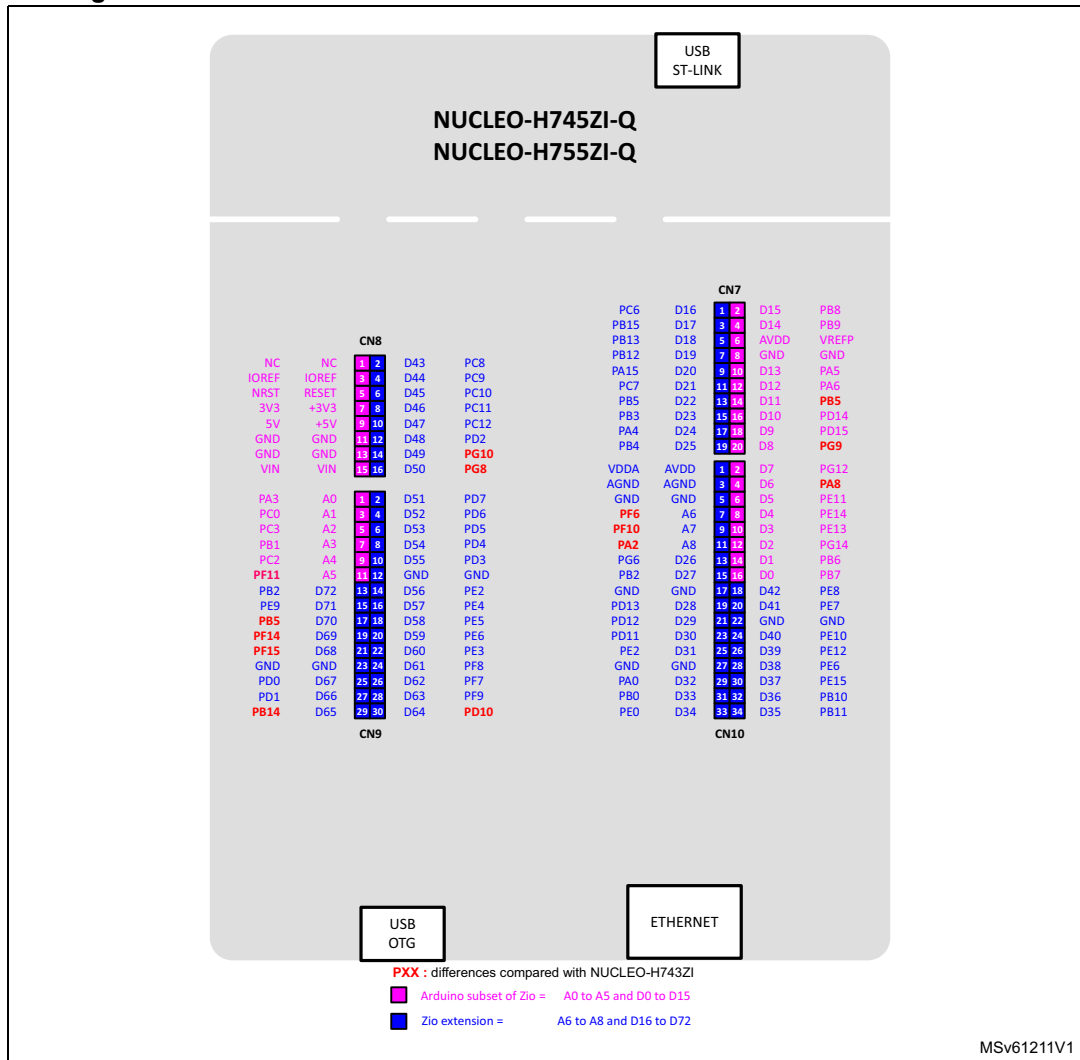
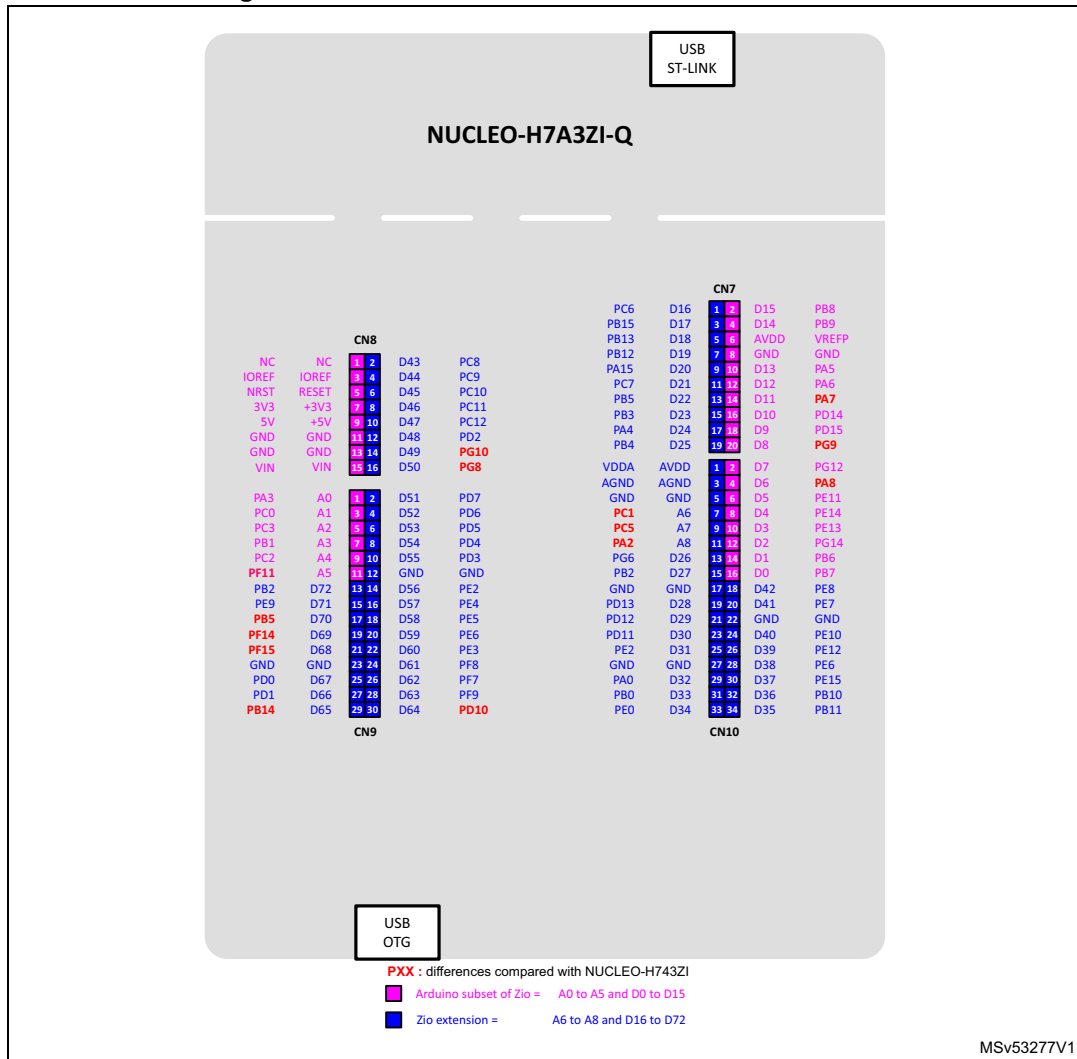

Figure 18. NUCLEO-H7A3ZI-Q extension connectors



6.16 ST Zio connectors

CN7, CN8, CN9, and CN10 are female connectors on the top side and male connectors on the bottom side. They include support for ARDUINO® Uno V3. Most shields designed for ARDUINO® Uno V3 can fit the STM32H7 Nucleo-144 board.

To cope with ARDUINO® Uno V3, apply the following modifications:

- SB39 and SB62 must be ON
- SB40 and SB69 must be OFF to connect I²C on A4 (Pin 5) and A5 (Pin 6 of CN9).

Caution:1 The I/Os of STM32H7 microcontroller are 3.3 V compatible instead of 5 V for ARDUINO® Uno V3.

Caution:2 R40 must be removed before implementing ARDUINO® shield with V_{REF+} power being provided on CN7 pin 6. Refer to [Table 16: Solder bridges](#) for details on R40.

[Table 17](#) shows the pin assignment for each STM32H7 microcontroller on the ST Zio connectors.

Table 17. NUCLEO-H745ZI-Q and NUCLEO-H755ZI-Q pin assignments

Connector	Pin	Pin name	Signal name	STM32H7 pin	Function	Remark
CN8	1	NC	NC	-	-	ARDUINO® support
	3	IOREF	IOREF	-	3.3 V Ref	ARDUINO® support
	5	NRST	NRST	NRST	RESET	ARDUINO® support
	7	3V3	3V3	-	3.3 V input/output	ARDUINO® support
	9	5V	5V	-	5 V output	ARDUINO® support
	11	GND	GND	-	ground	ARDUINO® support
	13	GND	GND	-	ground	ARDUINO® support
	15	VIN	VIN	-	Power input	ARDUINO® support
	2	D43	SDMMC_D0	PC8	SDMMC	-
	4	D44	SDMMC_D1/ SAI2_EXTCLK	PC9 ⁽¹⁾	SDMMC/I2S_A	-
	6	D45	SDMMC_D2	PC10	SDMMC	-
	8	D46	SDMMC_D3	PC11	SDMMC	-
	10	D47	SDMMC_CK	PC12	SDMMC	-
	12	D48	SDMMC_CMD	PD2	SDMMC	-
	14	D49	I/O	PG10 ⁽²⁾	I/O	-
	16	D50	I/O	PG8 ⁽³⁾	I/O	-

Table 17. NUCLEO-H745ZI-Q and NUCLEO-H755ZI-Q pin assignments (continued)

Connector	Pin	Pin name	Signal name	STM32H7 pin	Function	Remark
CN9	1	A0	ADC	PA3	ADC_12_INP15	ARDUINO® support
	3	A1	ADC	PC0	ADC_123_INP10	ARDUINO® support
	5	A2	ADC	PC3_C	ADC_3_INP1	ARDUINO® support
	7	A3	ADC	PB1	ADC_12_INP5	ARDUINO® support
	9	A4	ADC	PC2_C or PB9	ADC3_INP0 (PC2_C) or I2C1_SDA (PB9)	ARDUINO® support
	11	A5	ADC	PF11 or PB8	ADC1_INP2 (PF11) or I2C1_SCL (PB8)	ARDUINO® support
	13	D72	COMP1_INP	PB2 ⁽⁴⁾	COMP	NC by default
	15	D71	COMP2_INP	PE9	COMP	-
	17	D70	I2C_B_SMBA	PB5 ⁽⁵⁾	I2C_2	NC by default
	19	D69	I2C_B_SCL	PF14	I2C_2	-
	21	D68	I2C_B_SDA	PF15	I2C_2	-
	23	GND	GND	-	ground	-
	25	D67	CAN_RX	PD0	CAN_1	-
	27	D66	CAN_TX	PD1	CAN_1	-
	29	D65	I/O	PB14 ⁽⁶⁾	I/O	-
	2	D51	USART_B_SCLK	PD7	USART_2	-
	4	D52	USART_B_RX	PD6	USART_2	-
	6	D53	USART_B_TX	PD5	USART_2	-
	8	D54	USART_B_RTS	PD4	USART_2	-
	10	D55	USART_B_CTS	PD3	USART_2	-
	12	GND	GND	-	ground	-
	14	D56	SAI_A_MCLK	PE2 ⁽⁷⁾	SAI_1_A	-
	16	D57	SAI_A_FS	PE4	SAI_1_A	-
	18	D58	SAI_A_SCK	PE5	SAI_1_A	-
	20	D59	SAI_A_SD	PE6 ⁽⁸⁾	SAI_1_A	-
	22	D60	SAI_B_SD	PE3	SAI_1_B	-
	24	D61	SAI_B_SCK	PF8	SAI_1_B	-
	26	D62	SAI_B_MCLK	PF7	SAI_1_B	-
	28	D63	SAI_B_FS	PF9	SAI_1_B	-
	30	D64	I/O	PD10 ⁽⁹⁾	I/O	NC by default

Table 17. NUCLEO-H745ZI-Q and NUCLEO-H755ZI-Q pin assignments (continued)

Connector	Pin	Pin name	Signal name	STM32H7 pin	Function	Remark
CN7	1	D16	I2S_A_MCK	PC6	I2S_2	-
	3	D17	I2S_A_SD	PB15	I2S_2	-
	5	D18	I2S_A_CK	PB13 ⁽¹⁰⁾	I2S_2	NC by default
	7	D19	I2S_A_WS	PB12	I2S_2	-
	9	D20	I2S_B_WS	PA15	I2S_3	-
	11	D21	I2S_B_MCK	PC7	I2S_3	-
	13	D22	I2S_B_SD/ SPI_B_MOSI	PB5 ⁽⁵⁾	I2S_3 / SPI3	-
	15	D23	I2S_B_CK/ SPI_B_SCK	PB3 ⁽¹¹⁾	I2S_3 / SPI3	-
	17	D24	SPI_B_NSS	PA4	SPI3	-
	19	D25	SPI_B_MISO	PB4	SPI3	-
	2	D15	I2C_A_SCL	PB8	I2C1_SCL	ARDUINO [®] support
	4	D14	I2C_A_SDA	PB9	I2C1_SDA	ARDUINO [®] support
	6	AREF	AREF	-	AVDD/VREF+	ARDUINO [®] support
	8	GND	GND		ground	ARDUINO [®] support
	10	D13	SPI_A_SCK	PA5	SPI1_SCK	ARDUINO [®] support
	12	D12	SPI_A_MISO	PA6	SPI1_MISO	ARDUINO [®] support
	14	D11	SPI_A_MOSI/ TIM_E_PWM1	PB5 ⁽⁵⁾	SPI1_MOSI/ TIM3_CH2	ARDUINO [®] support
	16	D10	SPI_A_CS/ TIM_B_PWM3	PD14	SPI1_CS/ TIM4_CH3	ARDUINO [®] support
	18	D9	TIMER_B_PWM2	PD15	TIM4_CH4	ARDUINO [®] support
	20	D8	I/O	PG9 ⁽¹²⁾	-	ARDUINO [®] support

Table 17. NUCLEO-H745ZI-Q and NUCLEO-H755ZI-Q pin assignments (continued)

Connector	Pin	Pin name	Signal name	STM32H7 pin	Function	Remark
CN10	1	VDDA	VDDA	-	Analog VDD	-
	3	AGND	AGND	-	Analog ground	-
	5	GND	GND	-	ground	-
	7	A6	ADC_A_IN	PF6	ADC3_INP8	-
	9	A7	ADC_B_IN	PF10	ADC3_INP6	-
	11	A8	ADC_C_IN	PA2 ⁽¹³⁾	ADC12_INP14	NC by default
	13	D26	QSPI_CS	PG6	QSPI_BK1	-
	15	D27	QSPI_CLK	PB2 ⁽⁴⁾	QSPI_CLK	-
	17	GND	GND	-	ground	-
	19	D28	QSPI_BK1_IO3	PD13	QSPI_BK1	-
	21	D29	QSPI_BK1_IO1	PD12	QSPI_BK1	-
	23	D30	QSPI_BK1_IO0	PD11	QSPI_BK1	-
	25	D31	QSPI_BK1_IO2	PE2 ⁽⁷⁾	QSPI_BK1	-
	27	GND	GND	-	ground	-
	29	D32	TIMER_C_PWM1	PA0	TIM2_CH1	-
	31	D33	TIMER_D_PWM1	PB0	TIM3_CH3	-
	33	D34	TIMER_B_ETR	PE0	TIM4_ETR	-
	2	D7	I/O	PG12 ⁽¹⁴⁾	-	ARDUINO® support
	4	D6	TIMER_A_PWM1	PA8 ⁽¹⁵⁾	TIM1_CH1	ARDUINO® support
	6	D5	TIMER_A_PWM2	PE11	TIM1_CH2	ARDUINO® support
	8	D4	I/O	PE14	-	ARDUINO® support
	10	D3	TIMER_A_PWM3	PE13	TIM1_CH3	ARDUINO® support
	12	D2	I/O	PG14	-	ARDUINO® support
	14	D1	USART_A_TX	PB6	LPUART1	ARDUINO® support
	16	D0	USART_A_RX	PB7	LPUART1	ARDUINO® support
	18	D42	TIMER_A_PWM1N	PE8	TIM1_CH1N	-
	20	D41	TIMER_A_ETR	PE7	TIM1_ETR	-
	22	GND	GND	-	ground	-
	24	D40	TIMER_A_PWM2N	PE10	TIM1_CH2N	-
	26	D39	TIMER_A_PWM3N	PE12	TIM1_CH3N	-
	28	D38	I/O	PE6 ⁽⁸⁾	I/O	-
	30	D37	TIMER_A_BKIN1	PE15	TIM1_BKIN1	-
	32	D36	TIMER_C_PWM2	PB10	TIM2_CH3	-
	34	D35	TIMER_C_PWM3	PB11	TIM2_CH4	-

1. PC9 = SDMMC_D1 / SAI2_EXTCLK
2. PG10 = D49 / SMPS_SW
3. PG8 = D50 / SMPS_V1
4. PB2 = D27 / D72
5. PB5 = D11 (H745ZI / H755ZI) / D22 / D70
6. PB14 = D65 / LED_RED
7. PE2 = D31 / D56
8. PE6 = D59 / D38
9. PD10 = D64 / USB_FS_PWR_EN (H745ZI / H755ZI)
10. PB13 = D18 / RMII_TXD1 (H745ZI / H755ZI)
11. PB3 = D23 / SWO
12. PG9 = D8 / SMPS_EN
13. PA2 = A8 / RMII_MDIO (H745ZI / H755ZI)
14. PG12 = D7 / SMPS_PG
15. PA8 = D6 / USB_SOF / MCO1

For more details refer to [Table 16: Solder bridges](#).

Table 18. NUCLEO-H7A3ZI-Q pin assignments

Connector	Pin	Pin name	Signal name	STM32H7 pin	Function	Remark
CN8	1	NC	NC	-	-	ARDUINO® support
	3	IOREF	IOREF	-	3.3 V Ref	ARDUINO® support
	5	NRST	NRST	NRST	RESET	ARDUINO® support
	7	3V3	3V3	-	3.3 V input/output	ARDUINO® support
	9	5V	5V	-	5 V output	ARDUINO® support
	11	GND	GND	-	ground	ARDUINO® support
	13	GND	GND	-	ground	ARDUINO® support
	15	VIN	VIN	-	Power input	ARDUINO® support
	2	D43	SDMMC_D0	PC8	SDMMC	-
	4	D44	SDMMC_D1/ SAI2_EXTCLK	PC9 ⁽¹⁾	SDMMC/I2S_A	-
	6	D45	SDMMC_D2	PC10	SDMMC	-
	8	D46	SDMMC_D3	PC11	SDMMC	-
	10	D47	SDMMC_CK	PC12	SDMMC	-
	12	D48	SDMMC_CMD	PD2	SDMMC	-
	14	D49	I/O	PG10 ⁽²⁾	I/O	-
	16	D50	I/O	PG8 ⁽³⁾	I/O	-

Table 18. NUCLEO-H7A3ZI-Q pin assignments (continued)

Connector	Pin	Pin name	Signal name	STM32H7 pin	Function	Remark
CN9	1	A0	ADC	PA3	ADC_12_INP15	ARDUINO® support
	3	A1	ADC	PC0	ADC_123_INP10	ARDUINO® support
	5	A2	ADC	PC3_C	ADC_3_INP1	ARDUINO® support
	7	A3	ADC	PB1	ADC_12_INP5	ARDUINO® support
	9	A4	ADC	PC2_C or PB9	ADC3_INP0 (PC2_C) or I2C1_SDA (PB9)	ARDUINO® support
	11	A5	ADC	PF11 or PB8	ADC1_INP2 (PF11) or I2C1_SCL (PB8)	ARDUINO® support
	13	D72	COMP1_INP	PB2 ⁽⁴⁾	COMP	NC by default
	15	D71	COMP2_INP	PE9	COMP	-
	17	D70	I2C_B_SMBA	PB5 ⁽⁵⁾	I2C_2	NC by default
	19	D69	I2C_B_SCL	PF14	I2C_2	-
	21	D68	I2C_B_SDA	PF15	I2C_2	-
	23	GND	GND	-	ground	-
	25	D67	CAN_RX	PD0	CAN_1	-
	27	D66	CAN_TX	PD1	CAN_1	-
	29	D65	I/O	PB14 ⁽⁶⁾	I/O	-
	2	D51	USART_B_SCLK	PD7	USART_2	-
	4	D52	USART_B_RX	PD6	USART_2	-
	6	D53	USART_B_TX	PD5	USART_2	-
	8	D54	USART_B_RTS	PD4	USART_2	-
	10	D55	USART_B_CTS	PD3	USART_2	-
	12	GND	GND	-	ground	-
	14	D56	SAI_A_MCLK	PE2 ⁽⁷⁾	SAI_1_A	-
	16	D57	SAI_A_FS	PE4	SAI_1_A	-
	18	D58	SAI_A_SCK	PE5	SAI_1_A	-
	20	D59	SAI_A_SD	PE6 ⁽⁸⁾	SAI_1_A	-
	22	D60	SAI_B_SD	PE3	SAI_1_B	-
	24	D61	SAI_B_SCK	PF8	SAI_1_B	-
	26	D62	SAI_B_MCLK	PF7	SAI_1_B	-
	28	D63	SAI_B_FS	PF9	SAI_1_B	-
	30	D64	I/O	PD10 ⁽⁹⁾	I/O	-

Table 18. NUCLEO-H7A3ZI-Q pin assignments (continued)

Connector	Pin	Pin name	Signal name	STM32H7 pin	Function	Remark
CN7	1	D16	I2S_A_MCK	PC6	I2S_2	-
	3	D17	I2S_A_SD	PB15	I2S_2	-
	5	D18	I2S_A_CK	PB13 ⁽¹⁰⁾	I2S_2	-
	7	D19	I2S_A_WS	PB12	I2S_2	-
	9	D20	I2S_B_WS	PA15	I2S_3	-
	11	D21	I2S_B_MCK	PC7	I2S_3	-
	13	D22	I2S_B_SD/ SPI_B_MOSI	PB5 ⁽⁵⁾	I2S_3 / SPI3	-
	15	D23	I2S_B_CK/ SPI_B_SCK	PB3 ⁽¹¹⁾	I2S_3 / SPI3	-
	17	D24	SPI_B_NSS	PA4	SPI3	-
	19	D25	SPI_B_MISO	PB4	SPI3	-
	2	D15	I2C_A_SCL	PB8	I2C1_SCL	ARDUINO [®] support
	4	D14	I2C_A_SDA	PB9	I2C1_SDA	ARDUINO [®] support
	6	AREF	AREF	-	AVDD/VREF+	ARDUINO [®] support
	8	GND	GND		ground	ARDUINO [®] support
	10	D13	SPI_A_SCK	PA5	SPI1_SCK	ARDUINO [®] support
	12	D12	SPI_A_MISO	PA6	SPI1_MISO	ARDUINO [®] support
	14	D11	SPI_A_MOSI/ TIM_E_PWM1	PA7 ⁽⁵⁾	SPI1_MOSI/ TIM3_CH2	ARDUINO [®] support
	16	D10	SPI_A_CS/ TIM_B_PWM3	PD14	SPI1_CS/ TIM4_CH3	ARDUINO [®] support
	18	D9	TIMER_B_PWM2	PD15	TIM4_CH4	ARDUINO [®] support
	20	D8	I/O	PG9 ⁽¹²⁾	-	ARDUINO [®] support

Table 18. NUCLEO-H7A3ZI-Q pin assignments (continued)

Connector	Pin	Pin name	Signal name	STM32H7 pin	Function	Remark
CN10	1	VDDA	VDDA	-	Analog VDD	-
	3	AGND	AGND	-	Analog ground	-
	5	GND	GND	-	ground	-
	7	A6	ADC_A_IN	PC1	ADC12_INP1	-
	9	A7	ADC_B_IN	PC5	ADC12_INP8	-
	11	A8	ADC_C_IN	PA2 ⁽¹³⁾	ADC1_INP14	-
	13	D26	QSPI_CS	PG6	QSPI_BK1	-
	15	D27	QSPI_CLK	PB2 ⁽⁴⁾	QSPI_CLK	-
	17	GND	GND	-	ground	-
	19	D28	QSPI_BK1_IO3	PD13	QSPI_BK1	-
	21	D29	QSPI_BK1_IO1	PD12	QSPI_BK1	-
	23	D30	QSPI_BK1_IO0	PD11	QSPI_BK1	-
	25	D31	QSPI_BK1_IO2	PE2 ⁽⁷⁾	QSPI_BK1	-
	27	GND	GND	-	ground	-
	29	D32	TIMER_C_PWM1	PA0	TIM2_CH1	-
	31	D33	TIMER_D_PWM1	PB0	TIM3_CH3	-
	33	D34	TIMER_B_ETR	PE0	TIM4_ETR	-
	2	D7	I/O	PG12 ⁽¹⁴⁾	-	ARDUINO® support
	4	D6	TIMER_A_PWM1	PA8 ⁽¹⁵⁾	TIM1_CH1	ARDUINO® support
	6	D5	TIMER_A_PWM2	PE11	TIM1_CH2	ARDUINO® support
	8	D4	I/O	PE14	-	ARDUINO® support
	10	D3	TIMER_A_PWM3	PE13	TIM1_CH3	ARDUINO® support
	12	D2	I/O	PG14	-	ARDUINO® support
	14	D1	USART_A_TX	PB6	LPUART1	ARDUINO® support
	16	D0	USART_A_RX	PB7	LPUART1	ARDUINO® support
	18	D42	TIMER_A_PWM1N	PE8	TIM1_CH1N	-
	20	D41	TIMER_A_ETR	PE7	TIM1_ETR	-
	22	GND	GND	-	ground	-
	24	D40	TIMER_A_PWM2N	PE10	TIM1_CH2N	-
	26	D39	TIMER_A_PWM3N	PE12	TIM1_CH3N	-
	28	D38	I/O	PE6 ⁽⁸⁾	I/O	-
	30	D37	TIMER_A_BKIN1	PE15	TIM1_BKIN1	-
	32	D36	TIMER_C_PWM2	PB10	TIM2_CH3	-
	34	D35	TIMER_C_PWM3	PB11	TIM2_CH4	-

1. PC9 = SDMMC_D1 / SAI2_EXTCLK
2. PG10 = D49 / SMPS_SW
3. PG8 = D50 / SMPS_V1
4. PB2 = D27 / D72
5. PB5 = D11 (H745ZI / H755ZI) / D22 / D70
6. PB14 = D65 / LED_RED
7. PE2 = D31 / D56
8. PE6 = D59 / D38
9. PD10 = D64 / USB_FS_PWR_EN (H745ZI / H755ZI)
10. PB13 = D18 / RMII_TXD1 (H745ZI / H755ZI)
11. PB3 = D23 / SWO
12. PG9 = D8 / SMPS_EN
13. PA2 = A8 / RMII_MDIO (H745ZI / H755ZI)
14. PG12 = D7 / SMPS_PG
15. PA8 = D6 / USB_SOF / MCO1

6.17 ST morpho connector

The ST morpho connector consists in two male pin header footprints CN11 and CN12 (not soldered by default).

They are used to connect the STM32H7 Nucleo-144 board to an extension board or a prototype/wrapping board placed on top of the STM32H7 Nucleo-144 board. All signals and power pins of the STM32H7 are available on the ST morpho connector. This connector can also be probed by an oscilloscope, logical analyzer or voltmeter.

[Table 19](#) shows the assignment of each STM32H7 signal on the ST morpho connector.

Table 19. Pin assignment of MCU with ST morpho connector

CN11 odd pins		CN11 even pins		CN12 odd pins		CN12 even pins	
Pin nbr	Pin name	Pin nbr	Pin name	Pin nbr	Pin name	Pin nbr	Pin name
1	PC10	2	PC11	1	PC9	2	PC8
3	PC12	4	PD2	3	PB8	4	PC6
5	3V3_VDD	6	5V_EXT	5	PB9	6	PC5
7	BOOT0 ⁽¹⁾	8	GND	7	VREFP	8	5V_USB_STLK ⁽²⁾
9	PF6	10	NC	9	GND	10	PD8
11	PF7	12	IOREF	11	PA5	12	PA12 or NC ⁽³⁾
13	PA13 ⁽⁴⁾	14	NRST	13	PA6	14	PA11 or PE6 ⁽³⁾
15	PA14 ⁽⁴⁾	16	3V3	15	PA7	16	PB12
17	PA15	18	5V	17	PB6	18	PB11
19	GND	20	GND	19	PC7	20	GND
21	PB7	22	GND	21	PA9	22	PB2

Table 19. Pin assignment of MCU with ST morpho connector

CN11 odd pins		CN11 even pins		CN12 odd pins		CN12 even pins	
Pin nbr	Pin name	Pin nbr	Pin name	Pin nbr	Pin name	Pin nbr	Pin name
23	PC13	24	VIN	23	PA8	24	PB1
25	PC14	26	NC	25	PB10	26	PB15
27	PC15	28	PA0	27	PB4	28	PB14 or PE15 ⁽³⁾
29	PH0	30	PA1	29	PB5 or PA4 ⁽³⁾	30	PB13 or PE8 ⁽³⁾
31	PH1	32	PA4	31	PB3	32	AGND
33	VBAT	34	PB0	33	PA10	34	PC4
35	PC2	36	PC1	35	PA2	36	NC
37	PC3	38	PC0	37	PA3	38	NC
39	PD4	40	PD3	39	GND	40	PE8
41	PD5	42	NC	41	PD13	42	PF10
43	PD6	44	NC	43	PD12	44	PE7
45	PD7	46	PE2	45	PD11	46	PD14
47	PE3	48	PE4	47	PE10	48	PD15
49	GND	50	PE5	49	PE12	50	PF14
51	NC	52	NC	51	PE14	52	PE9
53	NC	54	PF8	53	PE15	54	GND
55	PD1	56	PF9	55	PE13	56	PE11
57	PD0	58	NC	57	NC	58	NC
59	NC	60	GND	59	NC	60	PF15
61	PE1	62	PE6	61	PG14	62	PF11
63	PG9	64	NC	63	GND	64	PE0
65	PG12	66	PG10	65	PD10	66	PG8
67	NC	68	PG13	67	PG7	68	NC
69	PD9	70	PG11	69	NC	70	PG6

1. Default state of BOOT0 is LOW. It can be set to HIGH when a jumper is ON between pins 5 and 7 of CN11. Refer to the warning at the end of [Section 6.4.8: Internal SMPS / LDO Configuration](#).
2. 5V_USB_STLK is the 5 V power coming from the ST-LINK/V3 USB connector that rises before and it rises before the +5 V rising on the board.
3. Solder bridges allow connecting to different pins. Refer to [Section 6.13: Motor control](#).
4. PA13 and PA14 are shared with SWD signals connected to ST-LINK/V3. It is not recommended to use them as I/O pins.

Appendix A Assembly drawings

Figure 19. Top assembly drawing

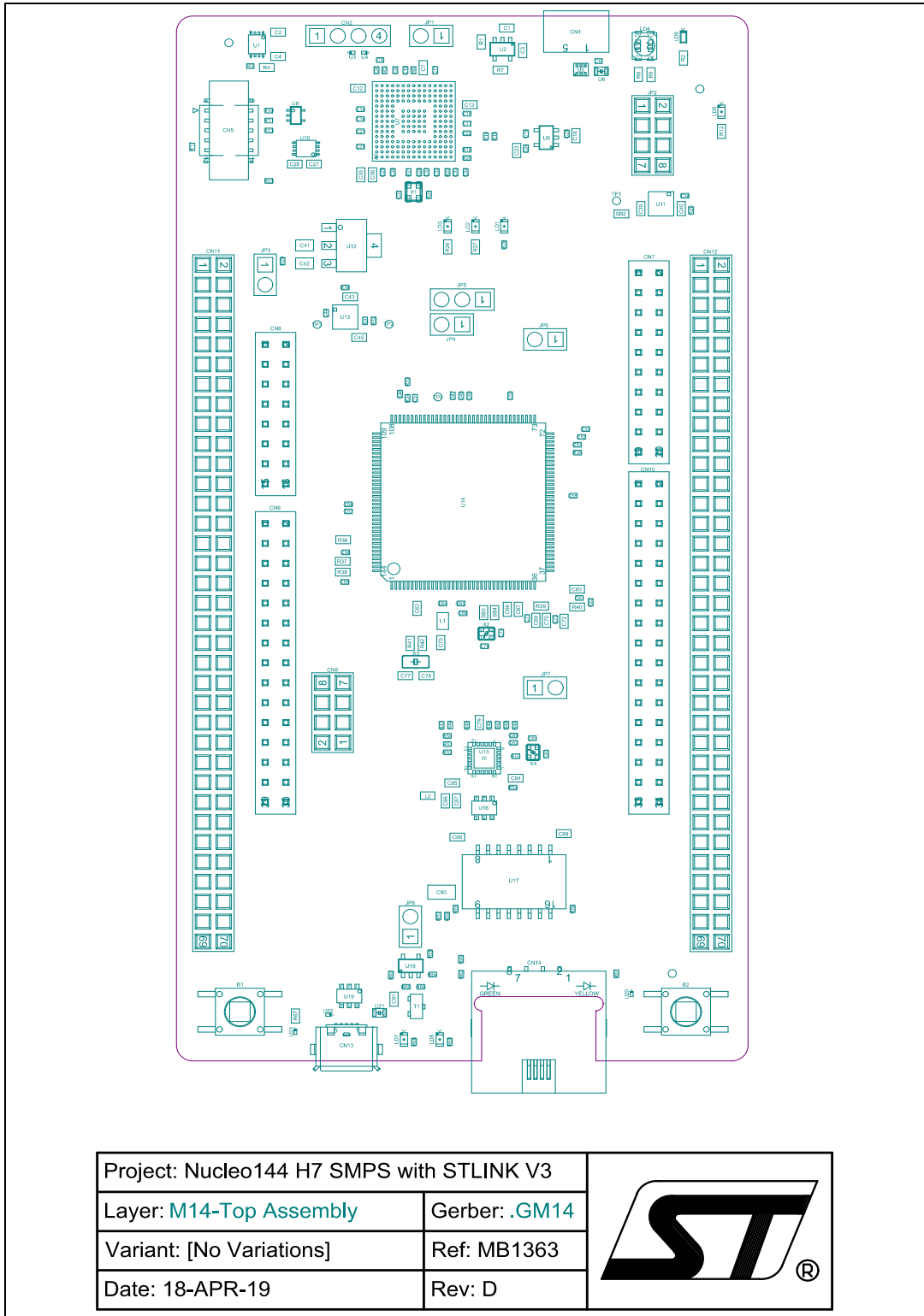
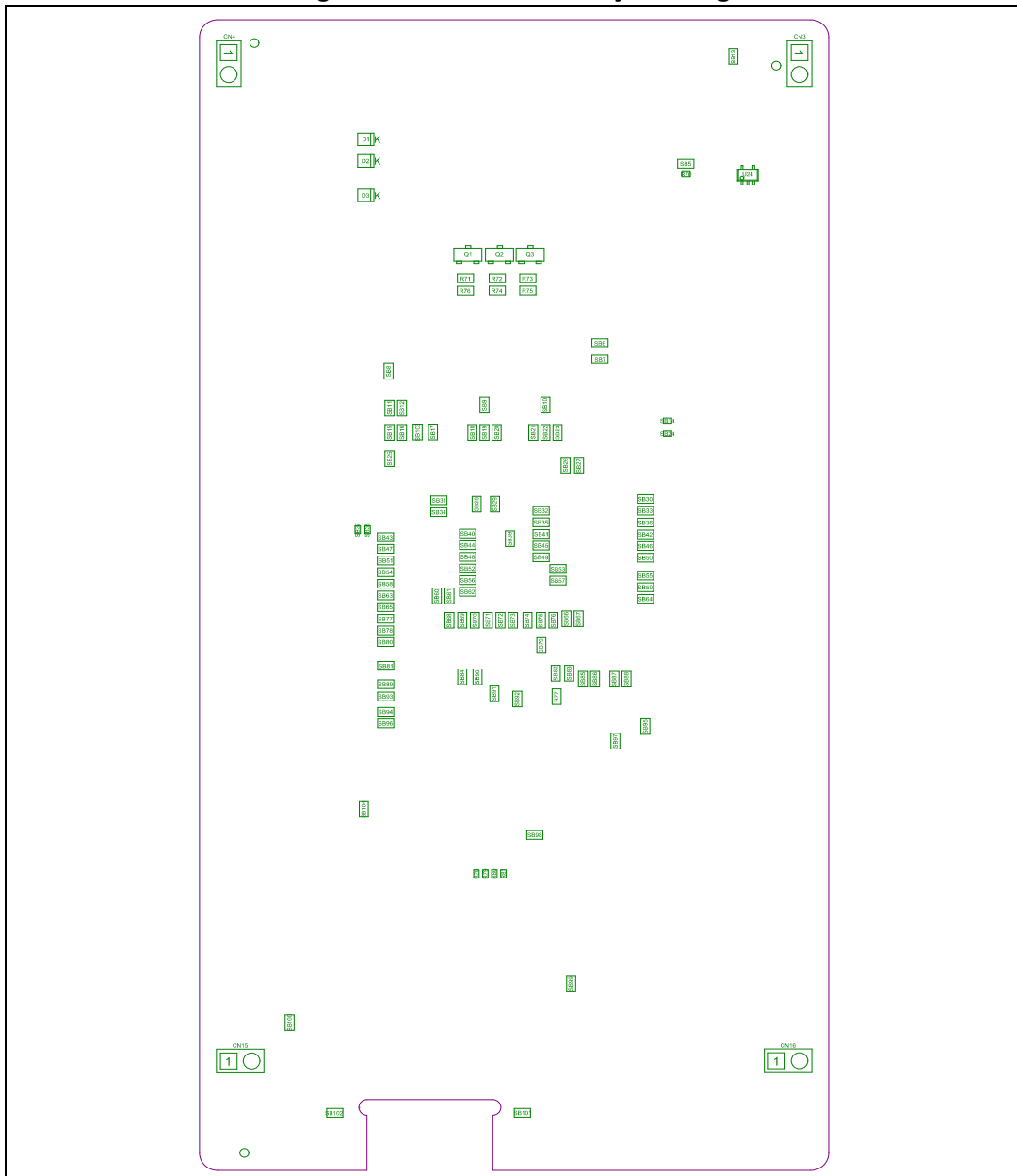



Figure 20. Bottom assembly drawing



Project: Nucleo144 H7 SMPS with STLINK V3		
Layer: M15-Bottom Assembly	Gerber:.GM15	
Variant: [No Variations]	Ref: MB1363	
Date: 18-APR-19	Rev: D	

Appendix B Federal Communications Commission (FCC) and Industry Canada (IC) Compliance

B.1 FCC Compliance Statement

B.1.1 Part 15.19

This device complies with Part 15 of the FCC Rules. Operation is subject to the following two conditions: (1) this device may not cause harmful interference, and (2) this device must accept any interference received, including interference that may cause undesired operation.

B.1.2 Part 15.105

This equipment has been tested and found to comply with the limits for a Class A digital device, pursuant to part 15 of the FCC Rules. These limits are designed to provide reasonable protection against harmful interference when the equipment is operated in a commercial environment. This equipment generates, uses, and can radiate radio frequency energy and, if not installed and used in accordance with the instruction manual, may cause harmful interference to radio communications. Operation of this equipment in a residential area is likely to cause harmful interference in which case the user will be required to correct the interference at his own expense.

B.1.3 Part 15.21

Any changes or modifications to this equipment not expressly approved by STMicroelectronics may cause harmful interference and void the user's authority to operate this equipment.

Note: Use only shielded cables.

RESPONSIBLE PARTY (IN USA)

Terry Blanchard | Tel: +1 972-466-7845

Americas Region Legal | Group Vice President and Regional Legal Counsel, The Americas
STMicroelectronics, Inc.

750 Canyon Drive | Suite 300 | Coppell, Texas 75019 | USA

B.2 IC Compliance Statement

This device complies with FCC and Industry Canada RF radiation exposure limits set forth for general population for mobile application (uncontrolled exposure). This device must not be collocated or operating in conjunction with any other antenna or transmitter.

B.2.1 Compliance Statement

Notice: This device complies with Industry Canada license-exempt RSS standard(s). Operation is subject to the following two conditions: (1) this device may not cause interference, and (2) this device must accept any interference, including interference that may cause undesired operation of the device.

Industry Canada ICES-003 Compliance Label: CAN ICES-3 (A)/NMB-3(A)

B.2.2 Déclaration de conformité

Avis: Le présent appareil est conforme aux CNR d'Industrie Canada applicables aux appareils radio exempts de licence. L'exploitation est autorisée aux deux conditions suivantes: (1) l'appareil ne doit pas produire de brouillage, et (2) l'utilisateur de l'appareil doit accepter tout brouillage radioélectrique subi, même si le brouillage est susceptible d'en compromettre le fonctionnement

Étiquette de conformité à la NMB-003 d'Industrie Canada: CAN ICES-3 (A)/NMB-3(A)

7 Revision history

Table 20. Document revision history

Date	Revision	Changes
13-Mar-2019	1	Initial version
19-Dec-2019	2	Updated: <ul style="list-style-type: none"> – New PCB (MB1363 Rev.D) with corrections of IDD current measurement issues – Important Warning concerning firmware versus hardware SMPS power configuration mismatch Added: <ul style="list-style-type: none"> – Support of NUCLEO-H7A3ZI-Q
10-Mar-2020	3	Updated: <ul style="list-style-type: none"> – Section 6.4.8: Internal SMPS / LDO Configuration with Table 10 and Figure 16 modifying supply configuration from external SMPS to bypass – Section 6.13: Motor control with Table 15
25-Mar-2020	4	Added: <ul style="list-style-type: none"> – New Section 6.17: ST morpho connector detailing connections with MCU in Table 19

IMPORTANT NOTICE – PLEASE READ CAREFULLY

STMicroelectronics NV and its subsidiaries (“ST”) reserve the right to make changes, corrections, enhancements, modifications, and improvements to ST products and/or to this document at any time without notice. Purchasers should obtain the latest relevant information on ST products before placing orders. ST products are sold pursuant to ST’s terms and conditions of sale in place at the time of order acknowledgement.

Purchasers are solely responsible for the choice, selection, and use of ST products and ST assumes no liability for application assistance or the design of Purchasers’ products.

No license, express or implied, to any intellectual property right is granted by ST herein.

Resale of ST products with provisions different from the information set forth herein shall void any warranty granted by ST for such product.

ST and the ST logo are trademarks of ST. For additional information about ST trademarks, please refer to www.st.com/trademarks. All other product or service names are the property of their respective owners.

Information in this document supersedes and replaces information previously supplied in any prior versions of this document.

© 2020 STMicroelectronics – All rights reserved