

Gate Drivers Base Board - Evaluation Board User's Manual

Description

SECO-GDBB-EVB is a baseboard conceived for use as a plug and play environment for testing various types of gate drivers. The main goal is to feed the drivers with the same control signal under same conditions and compare their capabilities.

It is set up to accommodate up to six driver boards (daughter boards) designed to test gate drivers functions and features (all driver boards are pin compatible with baseboard).

User can choose to place capacitor or power device as a load to the driver. Power devices are soldered to the board or connected to the board using screw terminals (TO-247 packages).

PWM signal is generated on board and is activated supplying voltage to the board. Onboard PWM is adjustable and user can define frequency in range of 10–200 kHz and duty cycle 0–100%. For fine-tuning and wider frequency range, it is possible to connect signal generator with BNC connector.

Nominal supply voltage is 15 V. Three isolated DC/DC converters provide supply for driver boards. Additional power connector is available to supply power devices, which are protected with 10 kΩ resistors. Board is not designed for power testing.

Features

- Plug and Play
- Adjustable Onboard PWM (Frequency and Duty Cycle)
- External PWM Generator
- 3 Isolated DC/DC Power Supplies for Driver Boards
- Gate Current and Gate Voltage Measurement
- Supply Voltage Range 15 V ±1 V

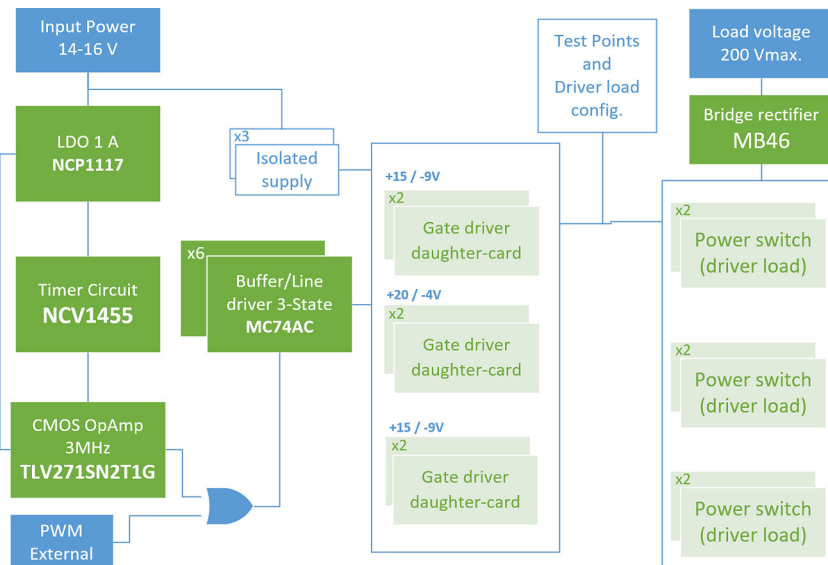

Figure 2. Block Diagram



ON Semiconductor®

www.onsemi.com

EVAL BOARD USER'S MANUAL

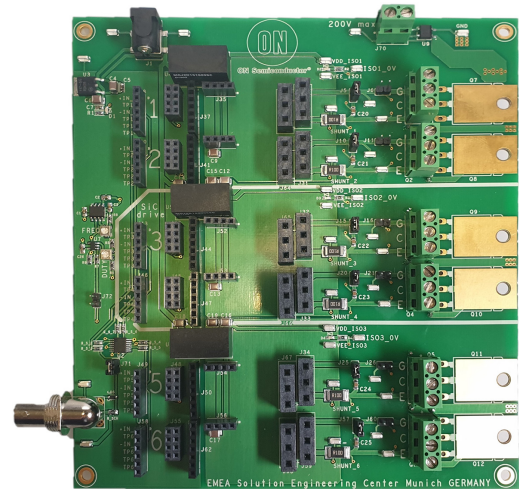

Figure 1. Evaluation Board Photo

User Interface Locations

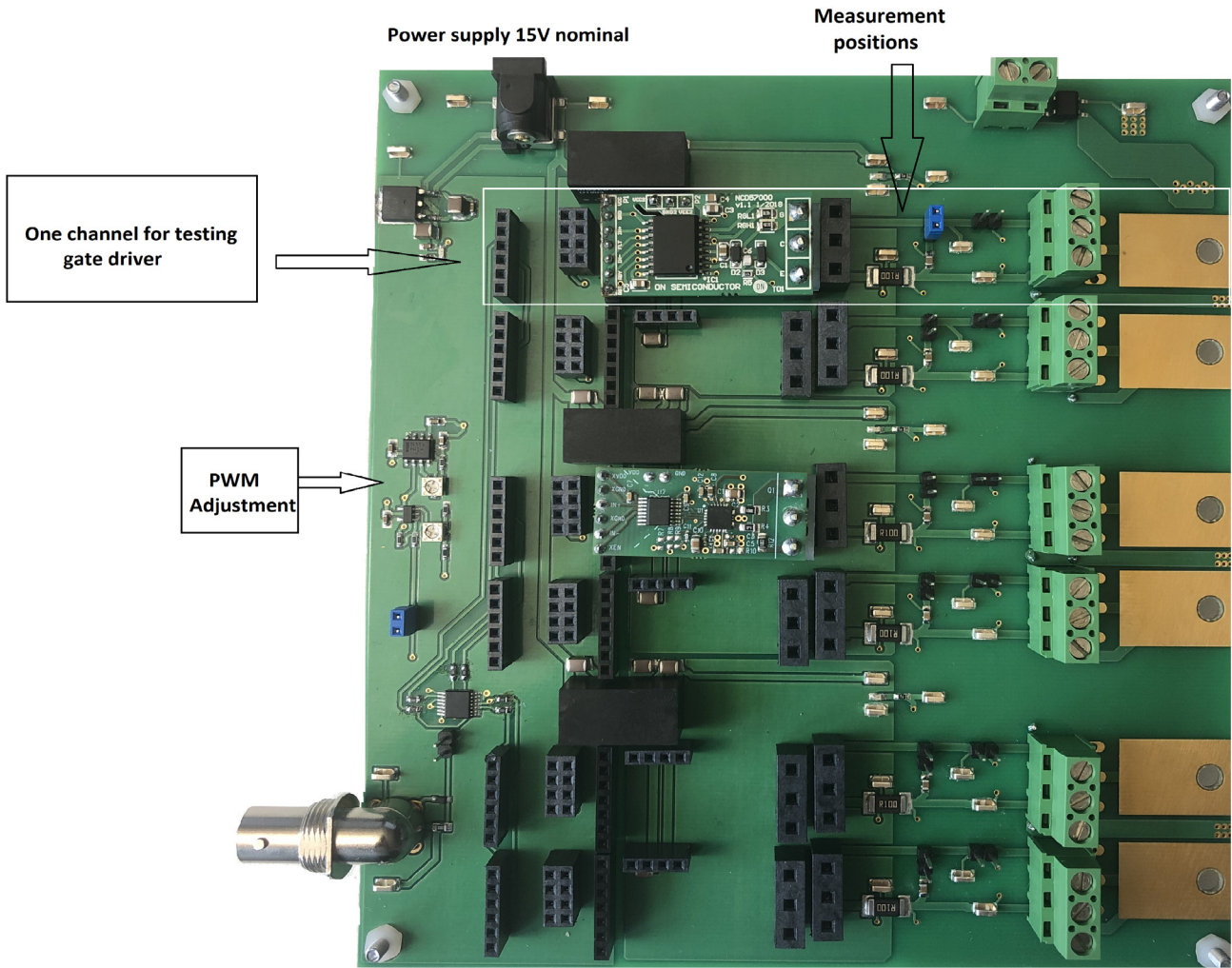

Figure 3. Board and Notable Segments

Voltage Supply

Once user has daughter boards with drivers to test, he should mount them into specified connectors.

NOTE: *Customer should take care on voltage supply for driver boards. Two middle positions on baseboard have supply of +20/-4 V, intended for SiC drivers. Other channels are supplied with +15/-9 V. Each channel provides also unipolar supply.*

After applying supply voltage to the board, all DC/DC converters will supply driver boards. (Figure 4.)

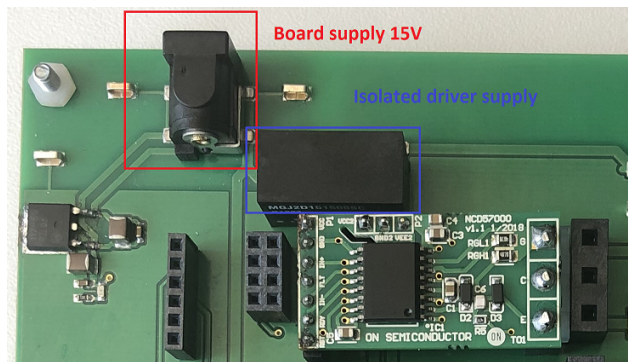

Figure 4.

PWM Generator

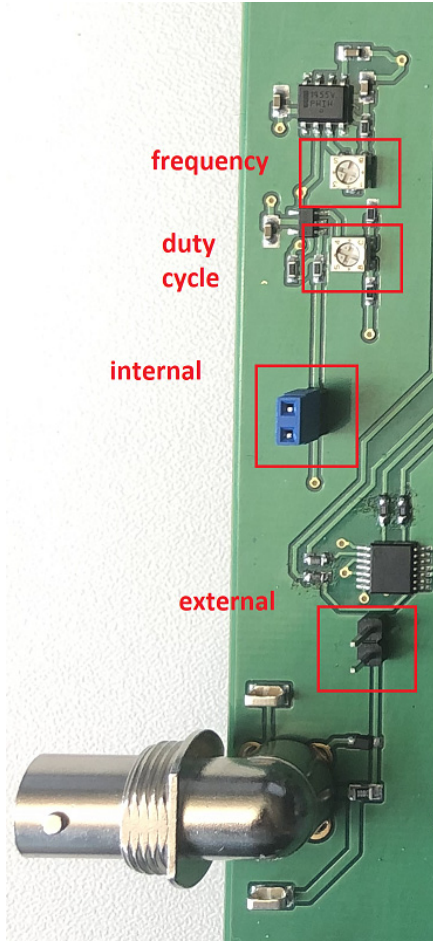

Figure 5. PWM Generator

Use potentiometers (Figure 5) to adjust frequency in range from 10–200 kHz and duty cycle from 0–100%. (Figure 6 and Figure 7).

First set up frequency and then duty cycle. Duty cycle sensitivity is decreasing with higher frequency.

Use jumpers in order to chose internal PWM generator or external one using BNC connector (Figure 5).

Internal PWM generator is activated immediately by applying voltage supply. Jumper should be placed once frequency and duty cycle are set up appropriately (in accordance to the limits of gate drivers in order to avoid possible damages).

Only one jumper shall be used for external or internal PWM generator. It is not advisable to connect external generator while internal one is not disconnected.

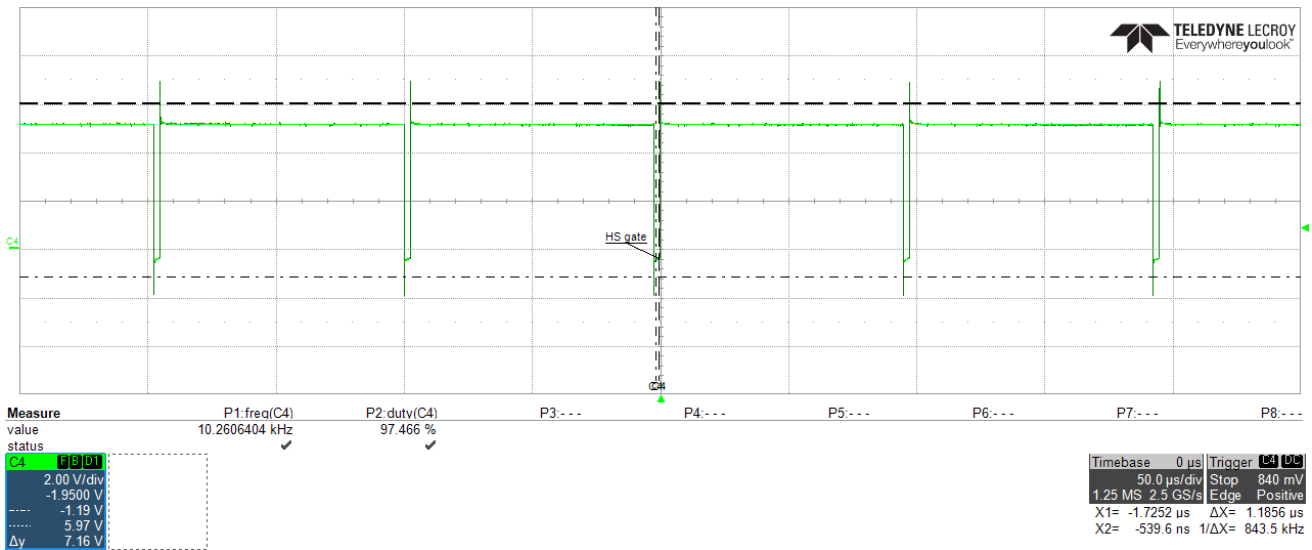

Figure 6. Minimum Frequency (On Board PWM Generator)

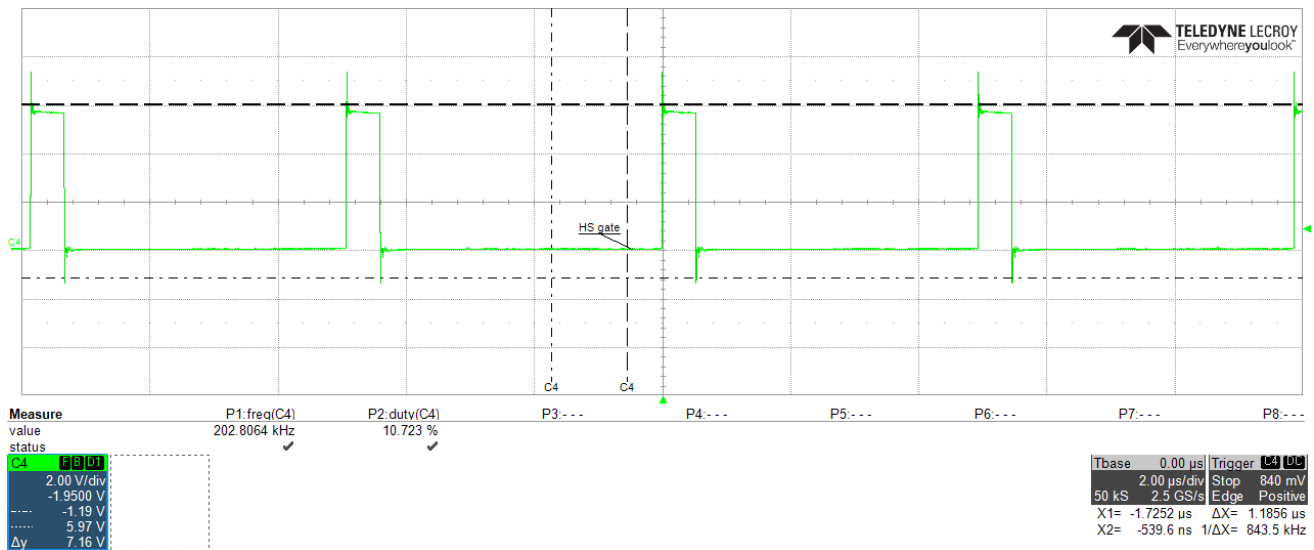

Figure 7. Maximum Frequency (On Board PWM Generator)

Capacitive Load or Power Device

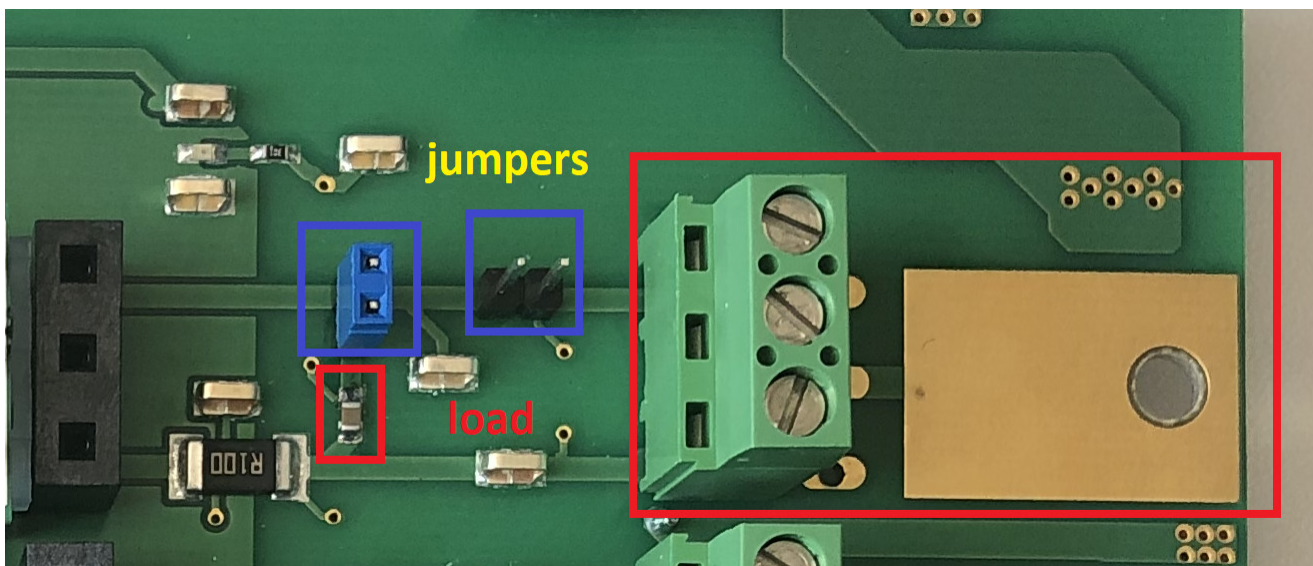

Figure 8. Driver Load (Capacitor or Power Device, Marked Red), Jumpers to Choose Load (Marked Blue)

User can choose capacitor or real power device as a load for gate driver. With jumpers user can select which one to use (Figure 8.)

If gate driver board with driver that supports de-saturation detection is in use and user chooses to use capacitor as a load, then collector/drain must be shorted

with emitter/source. Reason for that is when using capacitor as a load, driver is sensing collector/drain signal, which will be high and driver can recognize that as de-saturation and stop switching. Some drivers than need to reset in order to start switching again.

Gate Voltage and Gate Current Measurement

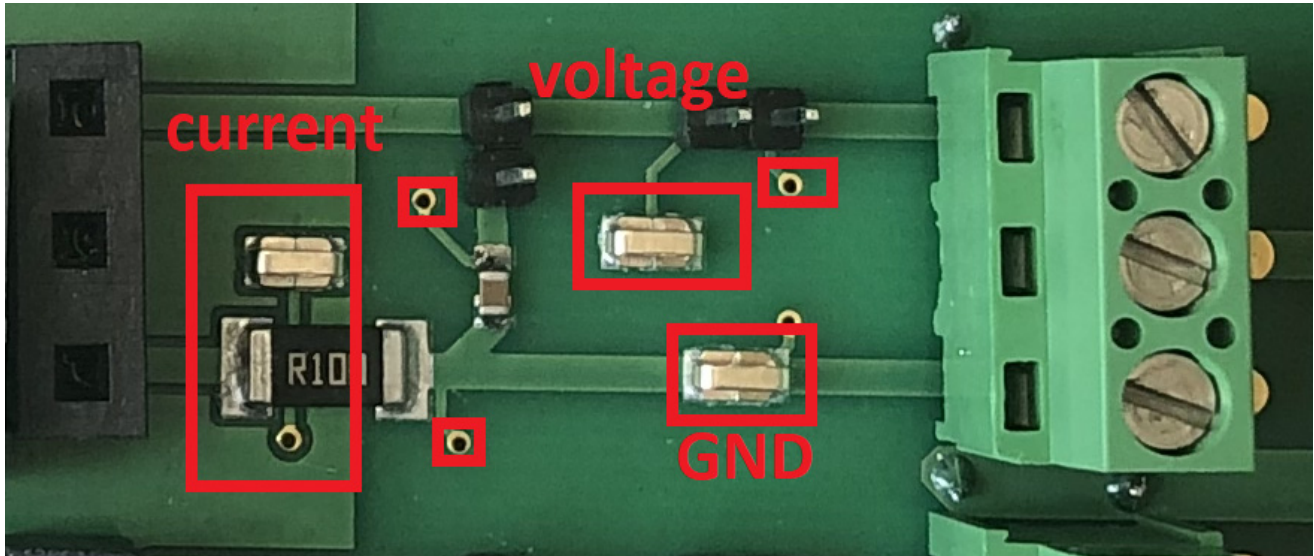

Figure 9. Measuring Positions

To measure gate current user can measure voltage drop across 100 mΩ shunt. It is recommended to use via connections and short measuring loops, but connectors are also provided. Gate voltage can be measured on capacitor

and/or power device, using connector or via connections. Figure 9 shows measuring positions and Figure 10 shows measuring result.

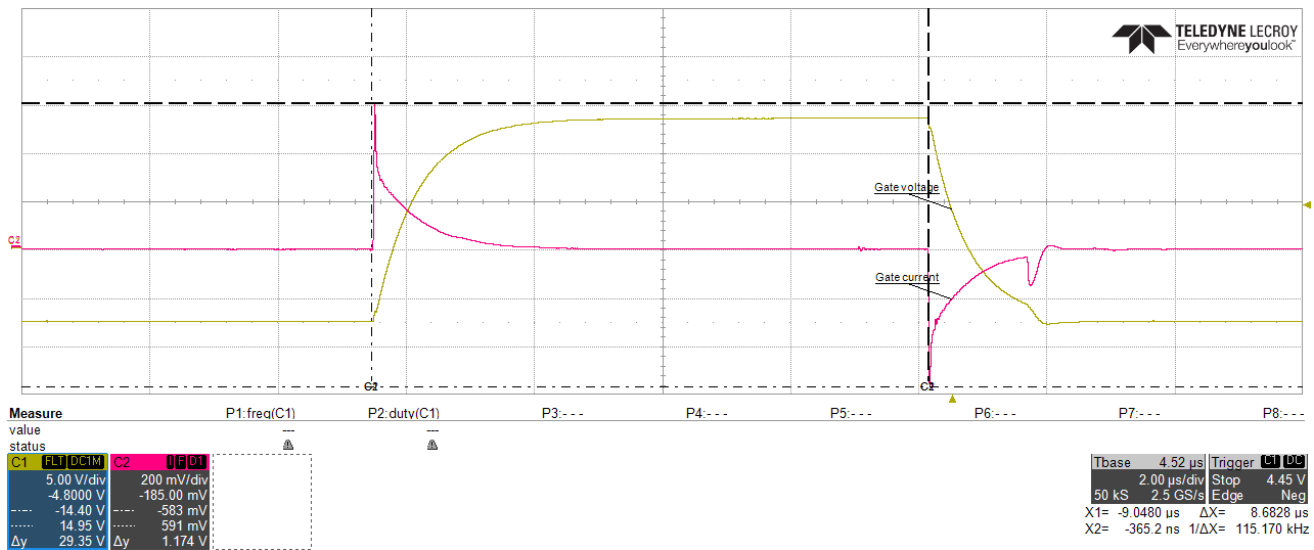

Figure 10. Gate Current and Voltage Measurements (Used Driver Board NCD57000)

Miller Effect

In order to evaluate driver’s performance with Miller effect, it is necessary to load driver with real power device and supply it with external voltage. Since this board is not

designed for power testing, user will not be able to apply high load currents and create high dv/dt (to increase Miller effect dominance).

SCHEMATICS

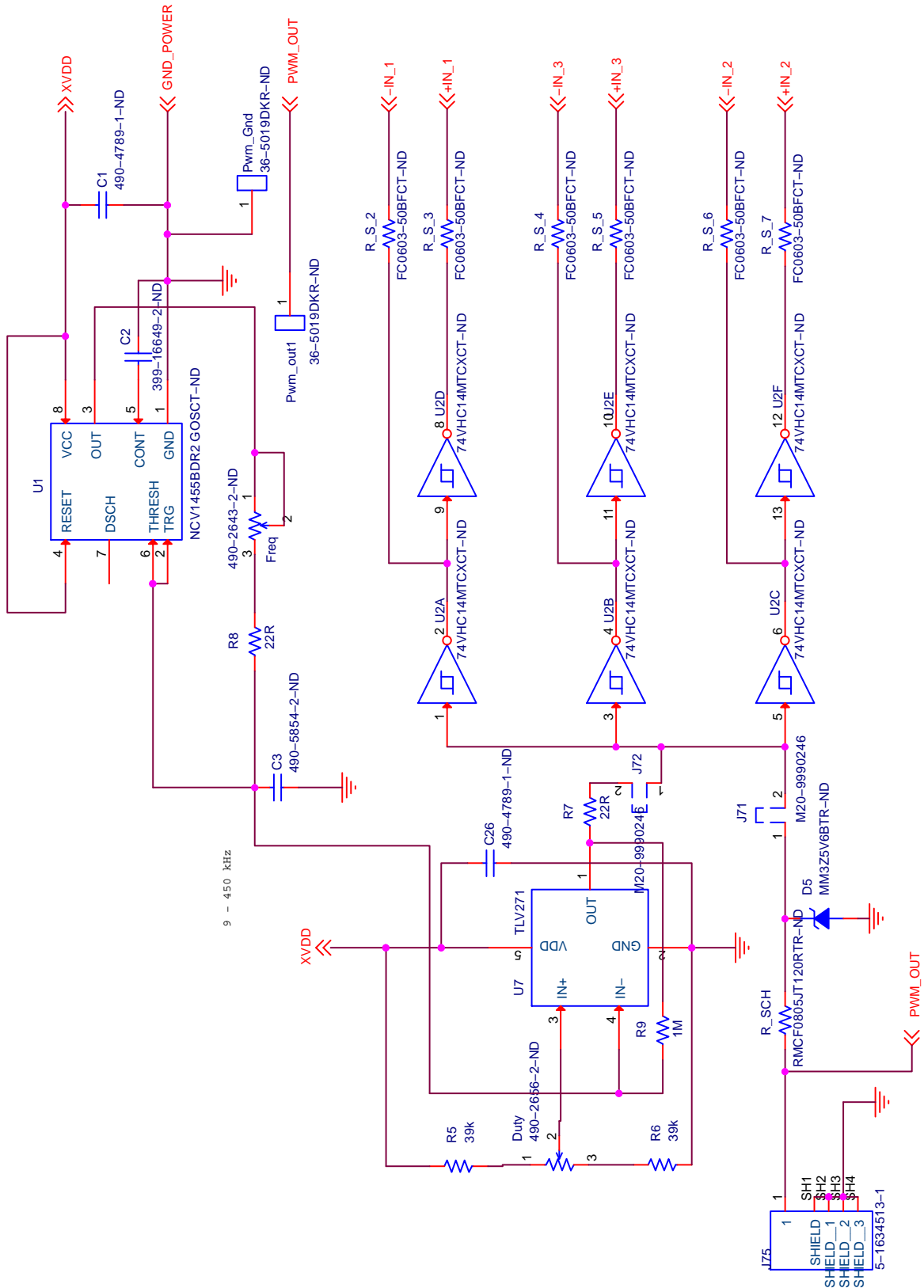

Figure 11. PWM Generator

SCHEMATICS (Continued)

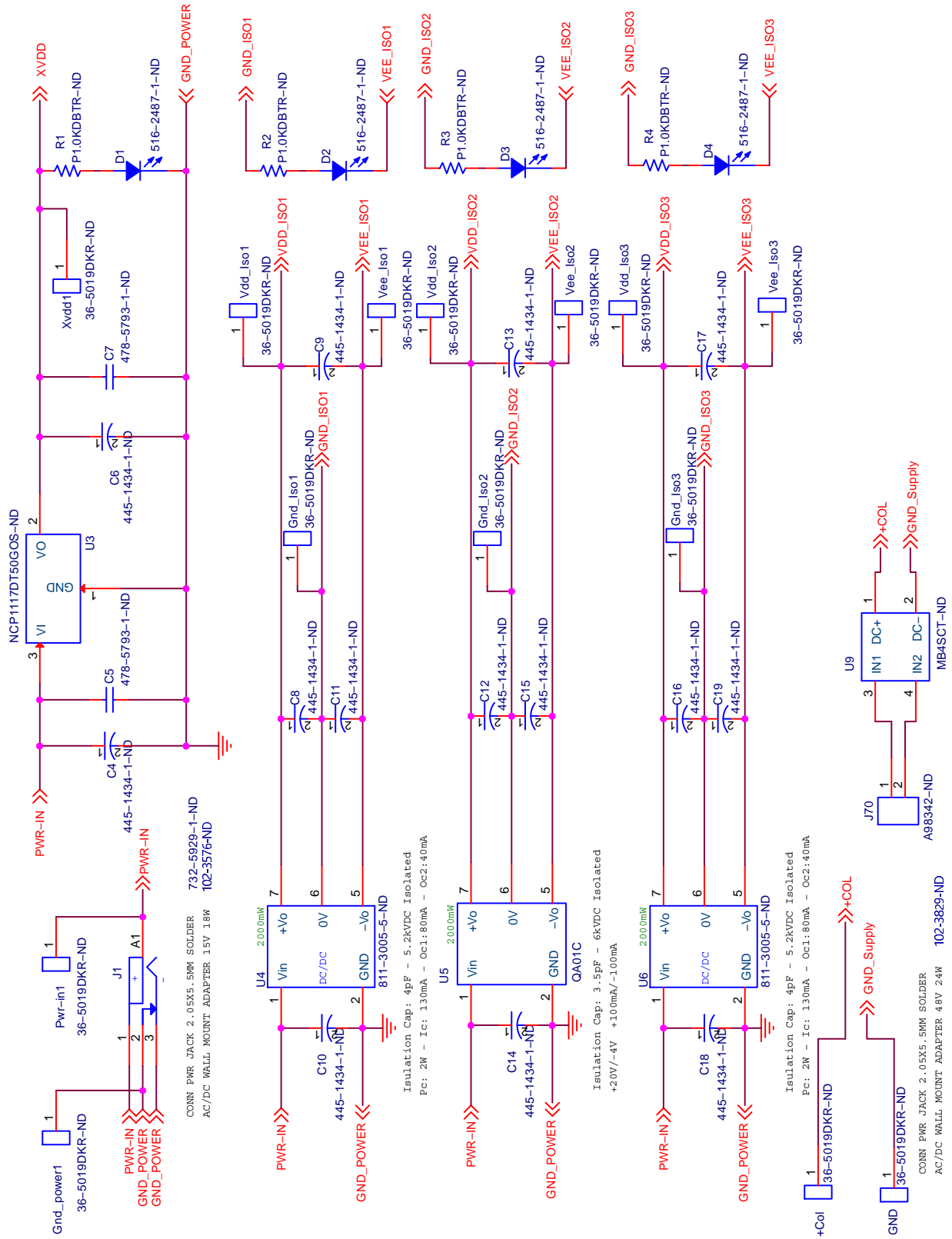

Figure 12. PWM Supply

SCHEMATICS (Continued)

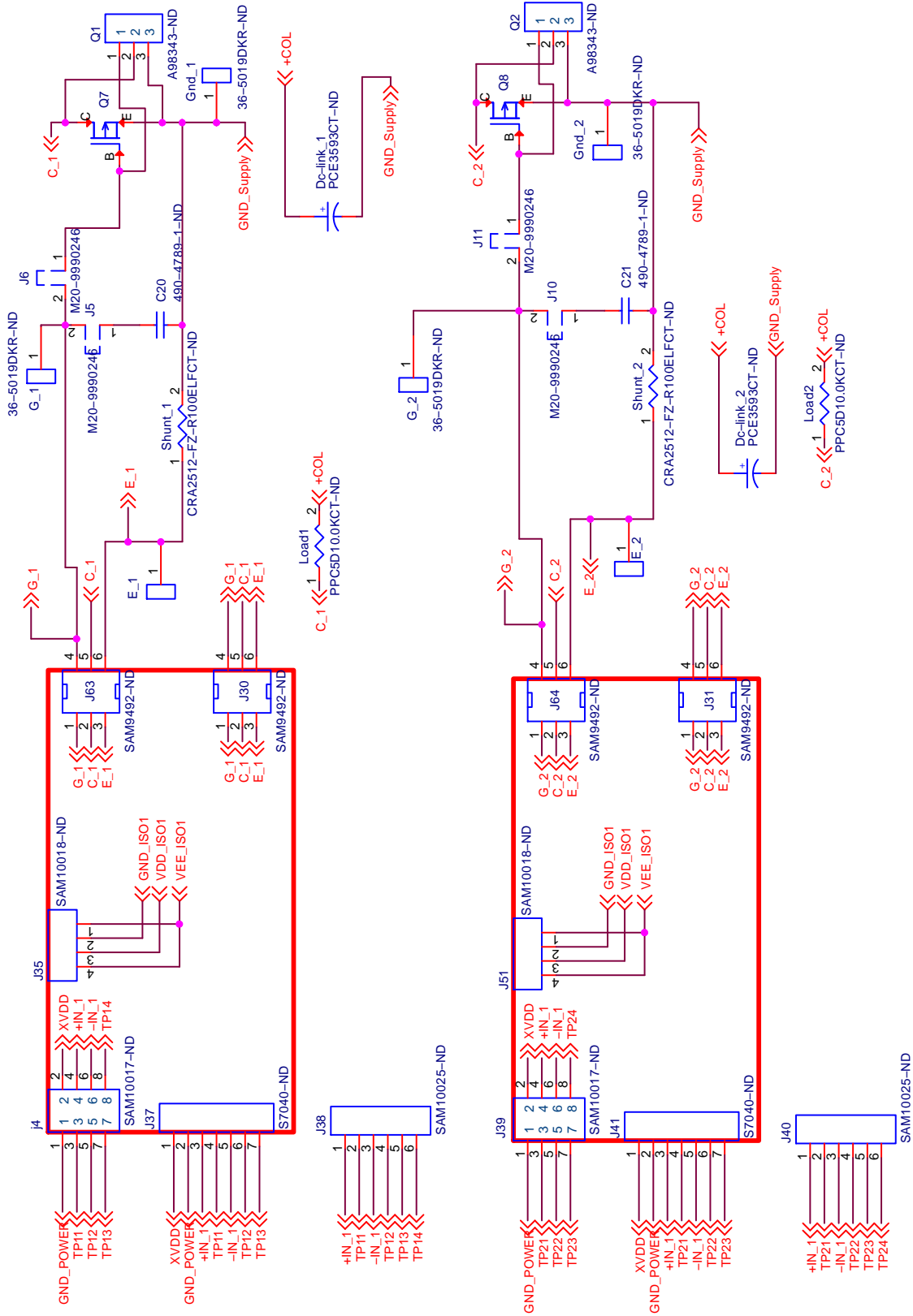

Figure 13. Channels 1 and 2 for Gate Drivers

SCHEMATICS (Continued)

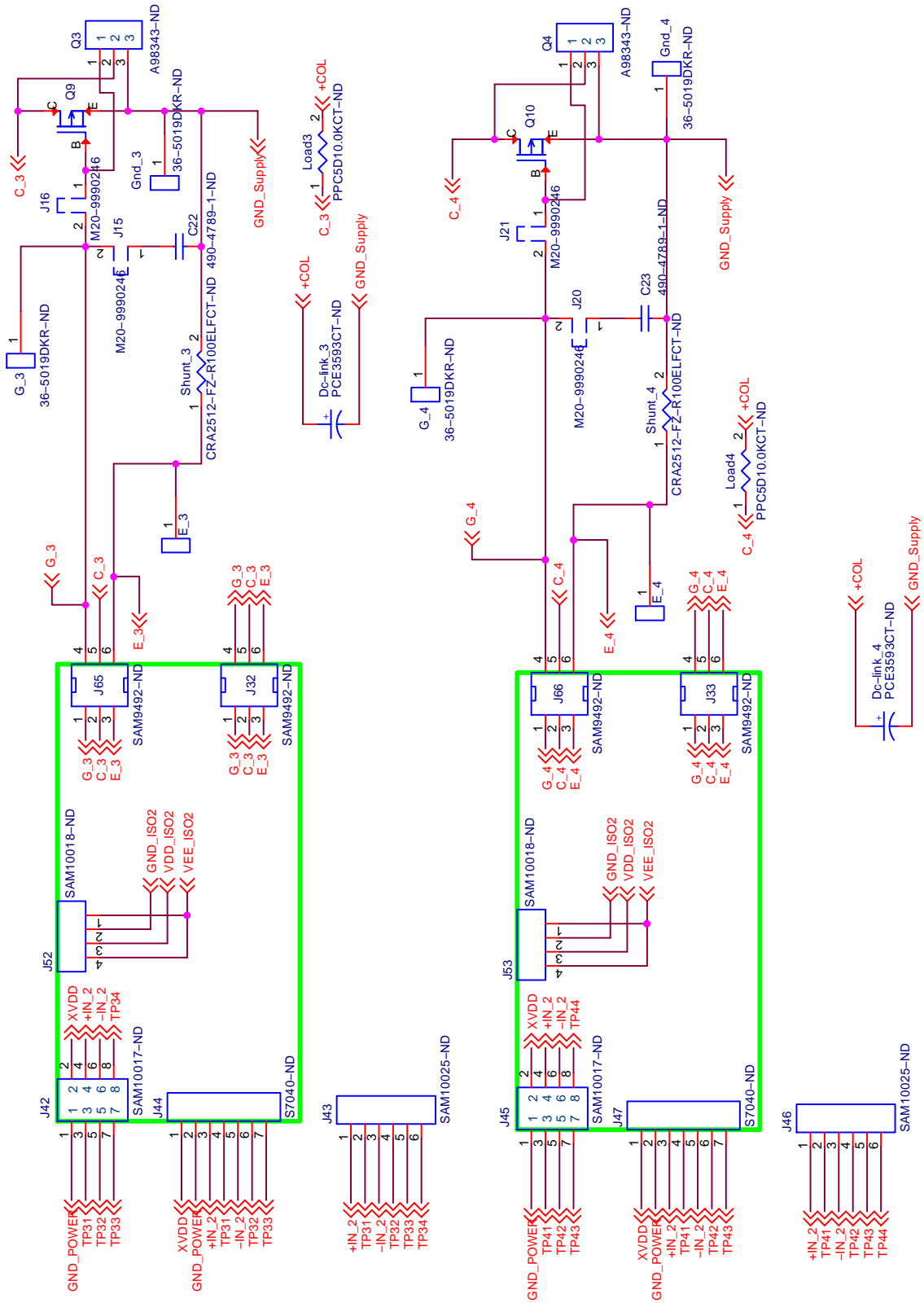

Figure 14. Channels 3 and 4 for Gate Drivers

ASSEMBLY

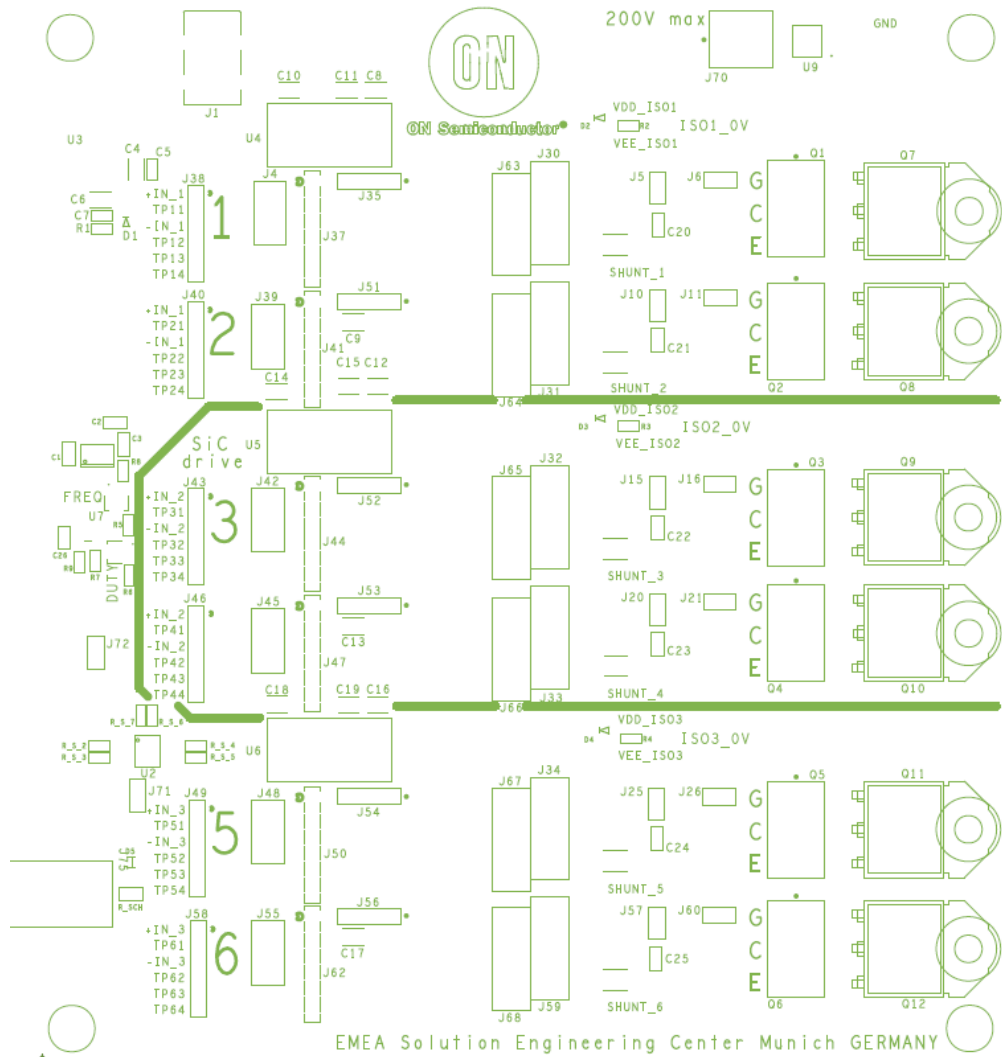

Figure 16. Top Side Assembly

EVBUM2702/D

ASSEMBLY (Continued)

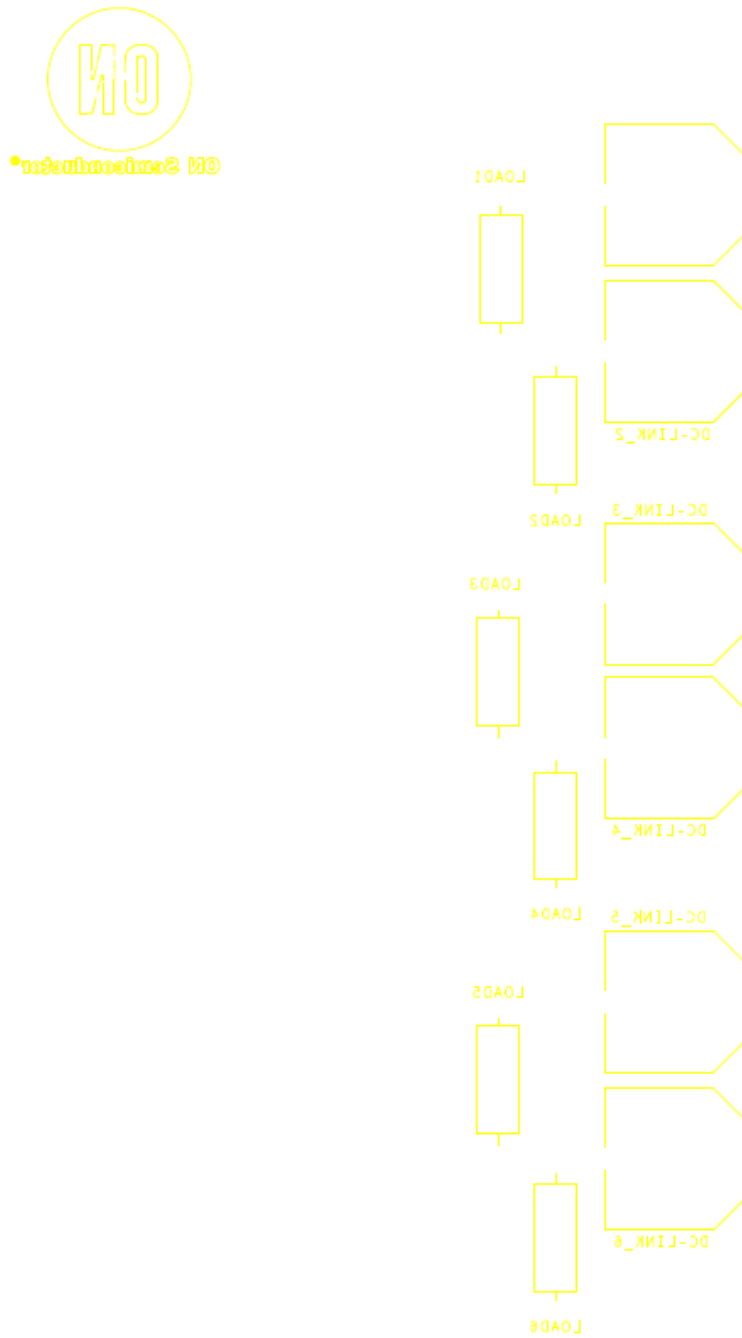

Figure 17. Bottom Side Assembly

EVBUM2702/D

BILL OF MATERIALS

Table 1. BILL OF MATERIALS

Item	Qty	Reference	Part	Manufacturer	Detailed Description	PCB Footprint
1	1	U1	NCV1455BDR2G	ON Semiconductor	IC OSC SINGLE TIMER 8SOIC	SOIC-8
2	1	U2	MC74AC14DTR2G	ON Semiconductor	IC INVERTER 6CH 6-INP 14TSSOP	TSSOP-14
3	1	U3	NCP1117DT50G	ON Semiconductor	Linear Voltage Regulator IC Positive Fixed 1 Output 5 V 1 A D ² PAK	DPAK
4	1	U7	TLV271SN2T1G	ON Semiconductor	IC OPAMP GP 1 CIRCUIT 5TSOP	SOT23-5
5	1	U9	MB4S	ON Semiconductor	Full bridge rectification, 400 V, 0.5 A	SOIC254P695X242-4N
6	34	Xvdd1, Vee_Iso1, Vdd_Iso1, Pwr-in1, Gnd_power1, Gnd_Iso1, Gnd_1, G_1, E_1, Vee_Iso2, Vdd_Iso2, Gnd_Iso2, Gnd_2, G_2, E_2, Vee_Iso3, Vdd_Iso3, Gnd_Iso3, Gnd_3, G_3, E_3, Gnd_4, G_4, E_4, Gnd_5, G_5, E_5, Gnd_6, G_6, E_6, GND, +Col, Pwm_out1, Pwm_Gnd	5019		TEST POINT MINI SMD	36-5019DKR-ND
7	3	C1, C2, C26	GCM188R71H104KA57D		CAP CER 0.1 μ F 50 V X7R 0603	sm_c_0805
8	1	C3	GCJ188R71H473KA12D		1 M Ω \pm 1% 0,1 W, Chip-Widerstand 0603	sm_c_0805
9	14	C4, C6, C8, C9, C10, C11, C12, C13, C14, C15, C16, C17, C18, C19	C3225X7R1H106M250AC		10 μ F \pm 20% 50 V Ceramic Capacitor X7R 1210 (3225 Metric)	1210
10	2	C5, C7	GCM188R71H104KA57D		0.1 μ F \pm 10% 50 V Ceramic Capacitor X7R 0603 (1608 Metric)	sm_c_0603
11	6	C20, C21, C22, C23, C24, C25	C0805C472K5RACTU		4.7 nF \pm 10% 50 V Ceramic Capacitor X7R 0805 (2012 Metric)	sm_c_0805
12	6	Dc-link_1, Dc-link_2, Dc-link_3, Dc-link_4, Dc-link_5, Dc-link_6	EEV-EB2V100SM		CAP ALUM 10 μ F 20% 350 V SMD	CAPAE1710X1650N
13	1	Duty	PVG3A503C01R00		TRIMMER 50 k Ω 0.25 W J LEAD TOP	TRIM_PVG3A200C01R00
14	4	D1, D2, D3, D4	HSMA-C191		Amber 592 nm LED Indication - Discrete 1.9 V 0603 (1608 Metric)	603
15	1	D5	MM3Z5V6B		DIODE ZENER 5.6 V 200 MW SOD323F	sod-323f
16	1	Freq	PVG3A102C01R00		TRIMMER 1 k Ω 0.25 W J LEAD TOP	TRIM_PVG3A200C01R00
17	1	J1	694106106102		Power connector jack	69410X106102

EVBUM2702/D

Table 1. BILL OF MATERIALS (continued)

Item	Qty	Reference	Part	Manufacturer	Detailed Description	PCB Footprint
18	14	J5, J6, J10, J11, J15, J16, J20, J21, J25, J26, J57, J60, J71, J72	M20-9990246		CONN HEADER VERT 2POS 2.54 MM	SAMTEC_TS-102-G-A
19	12	J30, J31, J32, J33, J34, J59, J63, J64, J65, J66, J67, J68	HPF-03-01-T-S		CONN RCPT 3POS 0.2 TIN PCB	SAM9492-ND
20	6	J35, J51, J52, J53, J54, J56	SSW-104-01-F-S		CONN RCPT 4POS 0.1 GOLD PCB	TE_826629-4
21	6	J37, J41, J44, J47, J50, J62	PPPC071LFBN-RC		CONN HDR 7POS 0.1 GOLD PCB	SAMTEC_SSQ-107-01-T-S
22	6	J38, J40, J43, J46, J49, J58	SSW-106-01-F-S		CONN RCPT 6POS 0.1 GOLD PCB	SAMTEC_TLW-106-05-G-S
23	6	J4, J39, J42, J45, J48, J55	SSW-104-01-F-D		CONN RCPT 8POS 0.1 GOLD PCB	SAMTEC_TD-104-G-A
24	1	J70	282841-2		Terminal block, wire to board	TE_282841-2
25	1	J75	5-16345-3-1		BNC LOW PROFILE ELBOW SOCKET 50 Ω	TE_5-1634513-1
26	6	Load1, Load2, Load3, Load4, Load5, Load6	PAC500001002FAC000		RES 10 kΩ 5 W 1% AXIAL	res_2w
27	6	Q1, Q2, Q3, Q4, Q5, Q6	282841-3		TERM BLK 3P SIDE ENT 5.08 MM PCB	TE_282841-3
28	6	Q7, Q8, Q9, Q10, Q11, Q12			No component, only footprint	SOT93
29	1	R_SCH	RMCF0805FT300R		RES 300 Ω 1% 1/8 W 0805	sm_r_0805
30	4	R1, R2, R3, R4	RMCF0603FT300R		300 Ω ±1% 0.1 W, 1/10 W Chip Resistor 0603 (1608 Metric) Automotive AEC-Q200 Thick Film	sm_r_0603
31	2	R5, R6	ERJ-3EKF3902V		39 kΩ ±1% 0.1 W, Chip-Widerstand 0603	sm_r_0603
32	2	R7, R8	ERJ-3EKF22R0V		22 Ω ±1% 0.1 W, Chip-Widerstand 0603	sm_r_0603
33	1	R9	ERJ-3EKF1001V		1 MΩ ±1% 0.1 W, Chip-Widerstand 0603	sm_r_0603
34	6	Shunt_1, Shunt_2, Shunt_3, Shunt_4, Shunt_5, Shunt_6	CRA2512-FZ-R100ELF		RES 0.1 Ω 1% 3 W 2512	SM_R_2512_bourns_cra
35	2	U4, U6	MGJ2D151509SC		Isolated Module DC DC Converter 2 Output 15 V -8.7 V 80 mA, 40 mA 13.5 V-16.5 V Input	SIP-7
36	1	U5	MGJ2D152005SC		DC/DC isolated converter 15 Vin, +20/-4 V output	SIP-7
37	6	R_S_2, R_S_3, R_S_4, R_S_5, R_S_6, R_S_7	RC0603JR-070RL		0 Ω SMD Resistor 0603	sm_r_0603
38	8	J5, J10, J15, J20, J25, J57, J71	QPC02SXGN-RC		CONN JUMPER SHORTING .100" GOLD	no footprint

ON Semiconductor and the ON Semiconductor logo are trademarks of Semiconductor Components Industries, LLC dba ON Semiconductor or its subsidiaries in the United States and/or other countries. ON Semiconductor owns the rights to a number of patents, trademarks, copyrights, trade secrets, and other intellectual property. A listing of ON Semiconductor's product/patent coverage may be accessed at www.onsemi.com/site/pdf/Patent-Marking.pdf. ON Semiconductor is an Equal Opportunity/Affirmative Action Employer. This literature is subject to all applicable copyright laws and is not for resale in any manner.

The evaluation board/kit (research and development board/kit) (hereinafter the "board") is not a finished product and is as such not available for sale to consumers. The board is only intended for research, development, demonstration and evaluation purposes and should as such only be used in laboratory/development areas by persons with an engineering/technical training and familiar with the risks associated with handling electrical/mechanical components, systems and subsystems. This person assumes full responsibility/liability for proper and safe handling. Any other use, resale or redistribution for any other purpose is strictly prohibited.

The board is delivered "AS IS" and without warranty of any kind including, but not limited to, that the board is production-worthy, that the functions contained in the board will meet your requirements, or that the operation of the board will be uninterrupted or error free. ON Semiconductor expressly disclaims all warranties, express, implied or otherwise, including without limitation, warranties of fitness for a particular purpose and non-infringement of intellectual property rights.

ON Semiconductor reserves the right to make changes without further notice to any board.

You are responsible for determining whether the board will be suitable for your intended use or application or will achieve your intended results. Prior to using or distributing any systems that have been evaluated, designed or tested using the board, you agree to test and validate your design to confirm the functionality for your application. Any technical, applications or design information or advice, quality characterization, reliability data or other services provided by ON Semiconductor shall not constitute any representation or warranty by ON Semiconductor, and no additional obligations or liabilities shall arise from ON Semiconductor having provided such information or services.

The boards are not designed, intended, or authorized for use in life support systems, or any FDA Class 3 medical devices or medical devices with a similar or equivalent classification in a foreign jurisdiction, or any devices intended for implantation in the human body. Should you purchase or use the board for any such unintended or unauthorized application, you shall indemnify and hold ON Semiconductor and its officers, employees, subsidiaries, affiliates, and distributors harmless against all claims, costs, damages, and expenses, and reasonable attorney fees arising out of, directly or indirectly, any claim of personal injury or death associated with such unintended or unauthorized use, even if such claim alleges that ON Semiconductor was negligent regarding the design or manufacture of the board.

This evaluation board/kit does not fall within the scope of the European Union directives regarding electromagnetic compatibility, restricted substances (RoHS), recycling (WEEE), FCC, CE or UL, and may not meet the technical requirements of these or other related directives.

FCC WARNING – This evaluation board/kit is intended for use for engineering development, demonstration, or evaluation purposes only and is not considered by ON Semiconductor to be a finished end product fit for general consumer use. It may generate, use, or radiate radio frequency energy and has not been tested for compliance with the limits of computing devices pursuant to part 15 of FCC rules, which are designed to provide reasonable protection against radio frequency interference. Operation of this equipment may cause interference with radio communications, in which case the user shall be responsible, at its expense, to take whatever measures may be required to correct this interference.

ON Semiconductor does not convey any license under its patent rights nor the rights of others.

LIMITATIONS OF LIABILITY: ON Semiconductor shall not be liable for any special, consequential, incidental, indirect or punitive damages, including, but not limited to the costs of requalification, delay, loss of profits or goodwill, arising out of or in connection with the board, even if ON Semiconductor is advised of the possibility of such damages. In no event shall ON Semiconductor's aggregate liability from any obligation arising out of or in connection with the board, under any theory of liability, exceed the purchase price paid for the board, if any.

For more information and documentation, please visit www.onsemi.com.

PUBLICATION ORDERING INFORMATION

LITERATURE FULFILLMENT:

Email Requests to: orderlit@onsemi.com

ON Semiconductor Website: www.onsemi.com

TECHNICAL SUPPORT

North American Technical Support:

Voice Mail: 1 800-282-9855 Toll Free USA/Canada

Phone: 011 421 33 790 2910

Europe, Middle East and Africa Technical Support:

Phone: 00421 33 790 2910

For additional information, please contact your local Sales Representative