

Getting started with ST25R3916-DISCO

Introduction

ST25R3916-DISCO is a ready-to-use development kit to evaluate the features and functionality in reader/writer, peer-to-peer and card emulation modes of the high-performance NFC universal device ST25R3916 for contactless applications.

The kit is composed of two boards:

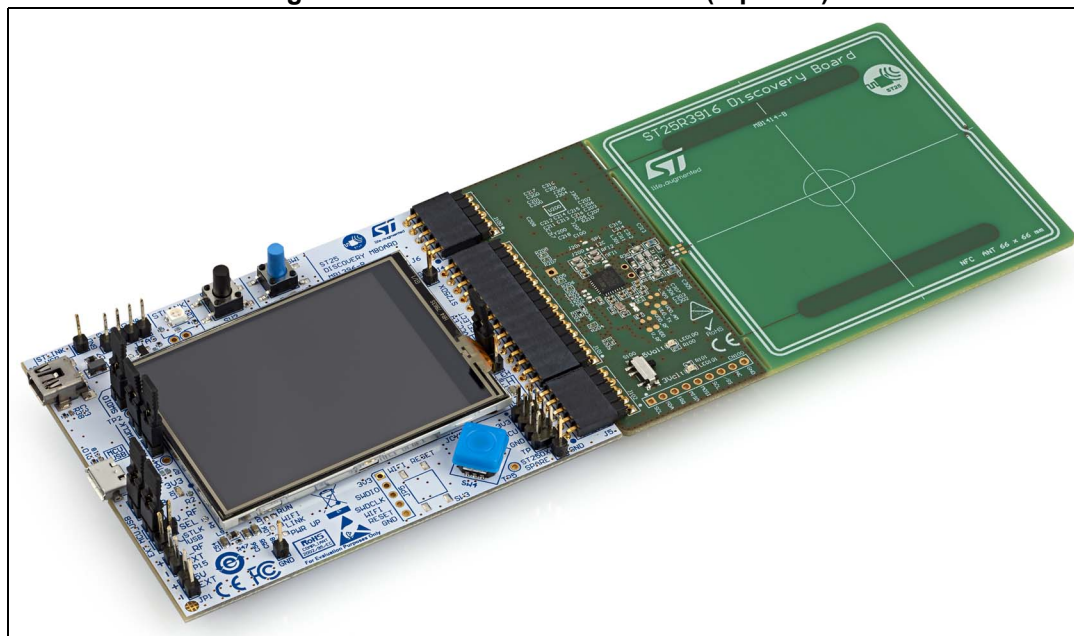
- MB1396 (ST25_Discovery_Mboard): a microprocessor motherboard, which includes a complement of hardware and software tools enabling the use the full STM32 Nucleo ecosystem. The board is powered through USB connectors.
- MB1414 (ST25R3916_Discovery_DB): a daughter board, which embeds the ST25R3916 device and an antenna etched on the PCB with its tuning circuit.

The communication link between the two boards is the SPI bus and the processor card provides the power. Specific data lines complete the pin connector assignment shared between cards.

A variety of demonstrations can be performed with this kit, which allows the users to develop and test their applications.

The MB1396 and the MB1414 boards schematics, BOM, Gerber files, drivers and firmware are available on the STMicroelectronics website www.st.com.

Figure 1. ST25R3916-DISCO board (top view)



Contents

- 1 Features 5**
- 2 Description 6**
- 3 Quick start 7**
 - 3.1 Getting started in standalone mode 7
 - 3.2 Getting started with USB mode 7
 - 3.3 System requirements 7
- 4 MB1396 hardware 8**
 - 4.1 MB1396 board layout 8
 - 4.2 MB1396 jumper default configuration 10
 - 4.3 MB1396 software development configuration 11
- 5 MB1414 hardware 12**
 - 5.1 ST25R3916 12
 - 5.2 Antenna and matching network components 12
 - 5.3 Board layout 13
- 6 Schematics 15**
- 7 Federal Communications Commission (FCC) and
Industry Canada (IC) compliance statements 29**
 - 7.1 FCC Compliance Statement 29
 - 7.1.1 Part 15.19 29
 - 7.1.2 Part 15.21 29
 - 7.1.3 FCC ID 29
 - 7.2 Formal notices required by the Industry Canada (“IC”) 29
 - 7.2.1 Compliance Statement 29
 - 7.2.2 Déclaration de Conformité 29
 - 7.2.3 IC ID 29
- 8 Revision history 30**

List of tables

Table 1.	Powering options	9
Table 2.	Jumpers configuration	10
Table 3.	Document revision history	30

List of figures

Figure 1.	ST25R3916-DISCO board (top view)	1
Figure 2.	Hardware connections	6
Figure 3.	MB1396 board (top view)	8
Figure 4.	MB1396 board (bottom view)	9
Figure 5.	MB1396 default configuration	10
Figure 6.	MB1396 SW development configuration	11
Figure 7.	MB1414 board (top view)	13
Figure 8.	MB1414 board (bottom view)	14
Figure 9.	MB1396 - Overview	16
Figure 10.	MB1396 - Power	17
Figure 11.	MB1396 - MCU	18
Figure 12.	MB1396 - Energy harvesting measurement	19
Figure 13.	MB1396 - ST Link - JTAG.	20
Figure 14.	MB1396 - LCD	21
Figure 15.	MB1396 - BLE and WiFi® modules	22
Figure 16.	MB1396 - Connectors	23
Figure 17.	MB1396 - USB	24
Figure 18.	MB1396 - Epaper connector	25
Figure 19.	MB1414 - Connectors	26
Figure 20.	MB1414 - ST25R3916	27
Figure 21.	MB1414 - Antenna and external load	28

1 Features

- ISO 18092 (NFCIP-1) active and passive initiator and target modes
- NFC Forum NFC-A, NFC-B, NFC-F and NFC-V reader
- ISO 14443A, ISO 14443B and ISO15693 reader
- FeliCa™ reader
- Support of all five NFC Forum Tag types in reader mode
- NFC Forum Type 3 tag (NFC-F) host card emulation
- NFC Forum Type 4A tag (NFC-A) host card emulation
- Stream modes to implement other standard and custom protocols
- Integrated capacitive sensing system for low power detection of tag presence
- Integrated inductive sensing system for low power detection of tag presence using phase or amplitude measurement
- High output power
- User selectable and automatic gain control
- Serial peripheral interface (SPI) up to 10 Mb/s
- I2C with up to 400 kbit/s in Fast-mode, 1 Mb/s in Fast-mode Plus
- Automatic antenna tuning (AAT) via variable capacitor

2 Description

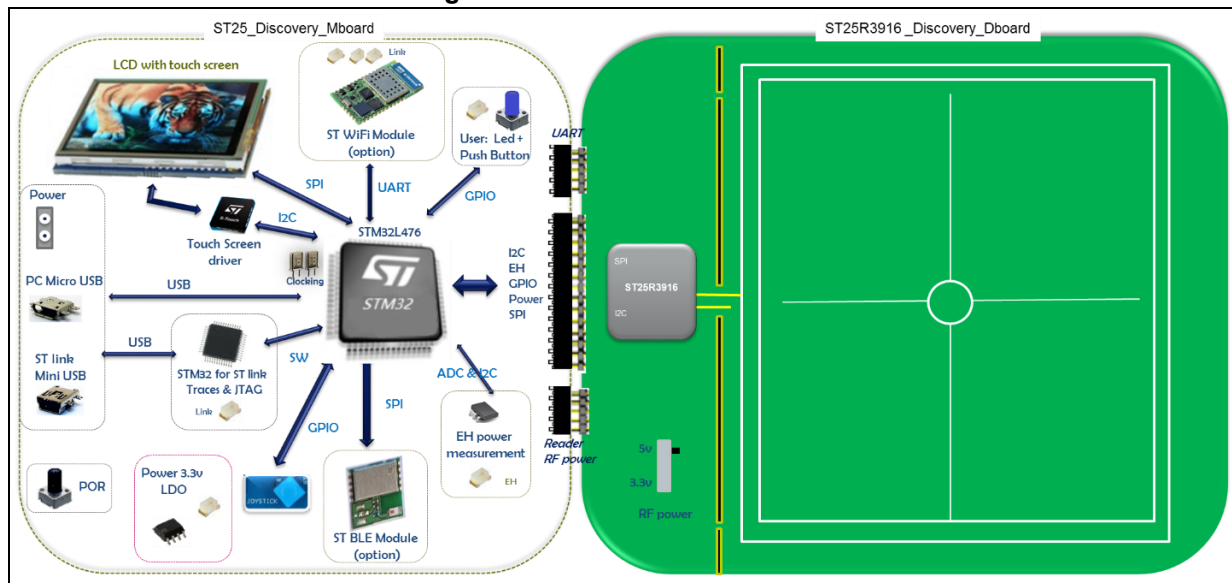
The ST25R3916-DISCO kit allows the user to evaluate the features and capabilities of the ST25R devices, a series of high performance HF readers.

The kit comes with application notes, software applications, drivers, BOM (bill of materials), board schematics, Gerber files and firmware schematics. All these documents can be downloaded from www.st.com, they help the user to reduce the design efforts.

The kit is composed of two boards:

1. The MB1396 (ST25_Discovery_Mboard) is a microprocessor motherboard embedding a 32-bit microcontroller of the STM32L476 line, based on Arm^{®(a)} Cortex[®]-M4 high-performance CPU with FPU.
The MB1396 is powered through the USB bus. It includes:
 - an ST-LINK in-circuit debugger and programmer for STM32 microcontrollers
 - a 2.4" TFT LCD with touch screen capability
 - LEDs
 - push buttons (reset and user)
 - a mini USB debug connector
 - a user-dedicated micro USB connector.
 - features for ST NFC TAG
2. The MB1414 (ST25R3916_Discovery_DB) daughter board, which embeds the ST25R3916, an antenna etched on the PCB and its tuning circuit. A switch allows the user to select 3.3 V or 5 V RF powering.

Figure 2. Hardware connections



arm

a. Arm is a registered trademark of Arm Limited (or its subsidiaries) in the US and/or elsewhere.

3 Quick start

3.1 Getting started in standalone mode

The motherboard and the daughter board must be connected together.

The jumper configuration when the kit is delivered is the default one.

The ST25R3916-DISCO kit is powered (like a PC) by the micro USB bus via a cable connected to the power source.

The unit must be supplied by a safety extra low voltage (SELV) limited power source through the USB port, the source must not exceed 60 V_{DC} / 8A / 100VA

When powered up, the microcontroller starts the firmware, which is already downloaded in the Flash memory.

This makes it possible to demonstrate the different capabilities of the ST25R3916.

- Reader and writer
- Card emulation
- Peer to peer
- Automatic antenna tuning
- USB mode (see [Section 3.2](#))

There is no need for modifications or configurations to run the demonstration. Refer to the firmware's user manual available on STMicroelectronics website to get more details.

3.2 Getting started with USB mode

Connect the discovery kit to a PC using a micro USB cable. The USB port of the PC must be capable of delivering at least 250 mA at 5 Volt.

To control the board, download the software from the dedicated page on www.st.com and install it. Further information on how to operate the software and the GUI that can be used to control the control the board can be found in UM2511 "ST25R3916-DISCO kit user manual", available on www.st.com.

3.3 System requirements

- Micro USB cable
- USB port, capable of delivering at least 250 mA at 5 V (1.25 W)
- Unit must be supplied by a safety extra low voltage (SELV) limited power source through the USB port
- For embedded ST link and STM32 Nucleo ecosystem development usage a mini USB cable is required

4 MB1396 hardware

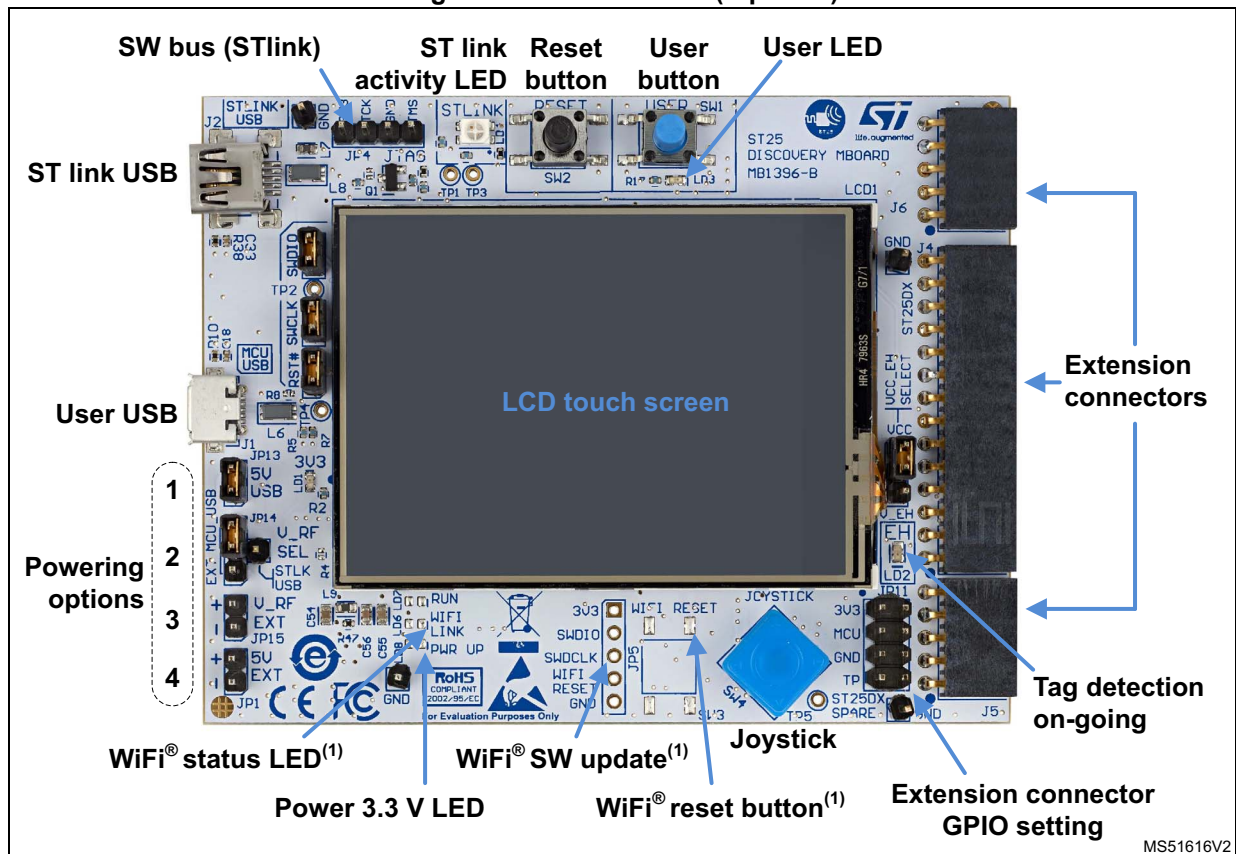
The PCB (printed circuit board) of the motherboard is usually connected via USB to the PC. The embedded firmware controls the STM32 MCU that operates the ST25R3916 via the extension connectors.

Both boards are powered by the 5 V supply of the USB bus. An LDO converts this voltage down to 3.3 V to supply the microcontroller and the ST25R3916. The extension board is provided with both 3.3 and 5 V supplies, it is possible to select one of them.

A green LED close to the motherboard micro USB plug indicates when the board is powered.

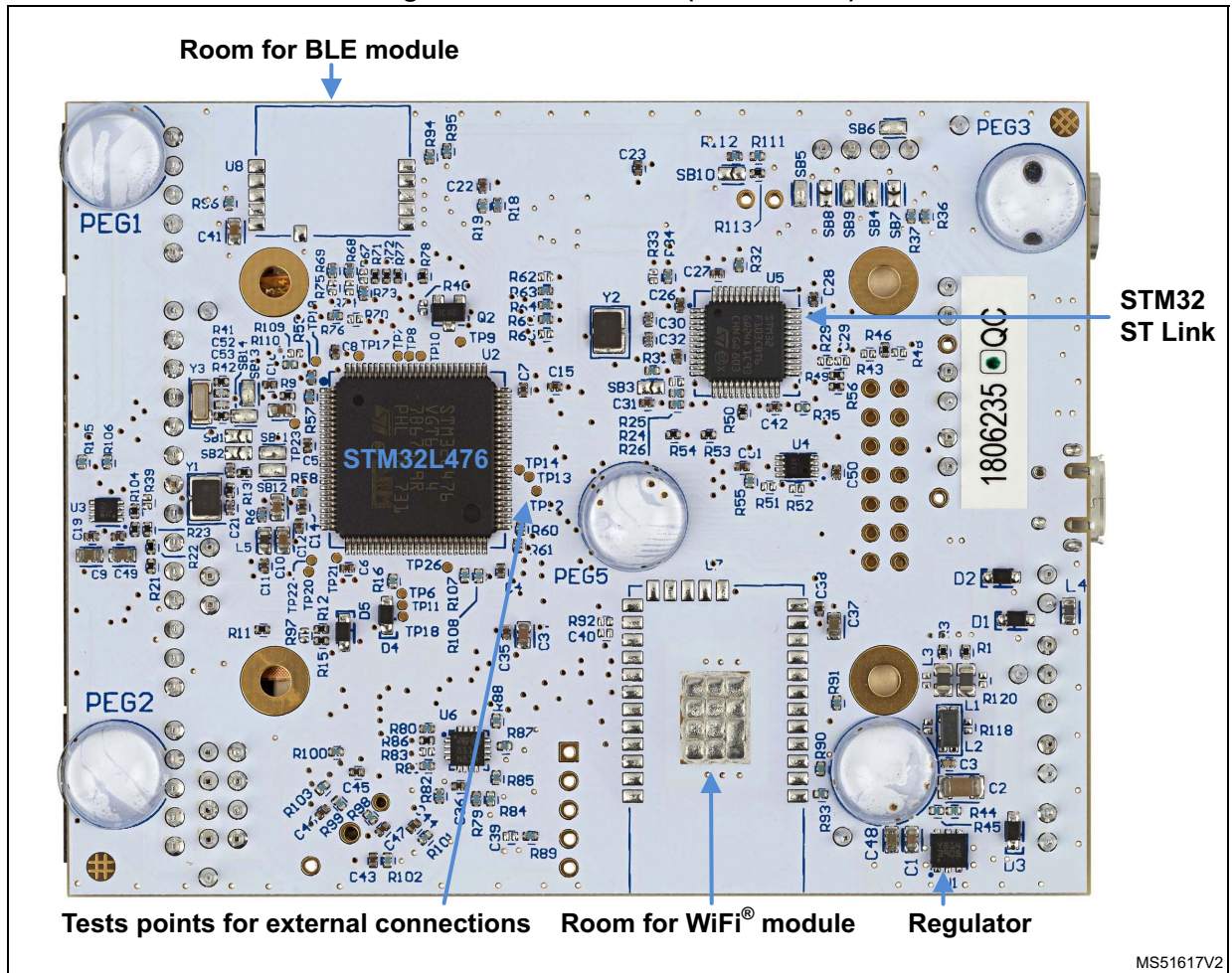
4.1 MB1396 board layout

Figure 3. MB1396 board (top view)



1. Available only on demonstration edition.

Figure 4. MB1396 board (bottom view)



MS51617V2

Table 1. Powering options

Reference	Connector	Position	Description
1	JP13	Closed 1-2	Card powered by USB
2	JP14	Closed 2-3	Card powered by micro USB
3	JP15	Open	ST25R3916 board powering, special feature
4	JP16	Open	Card powered by an external source

4.2 MB1396 jumper default configuration

This section details the MB1396 jumpers default configuration (recommended setting), set at kit delivery. With these parameters the USB micro connector provides the kit powering.

Figure 5. MB1396 default configuration

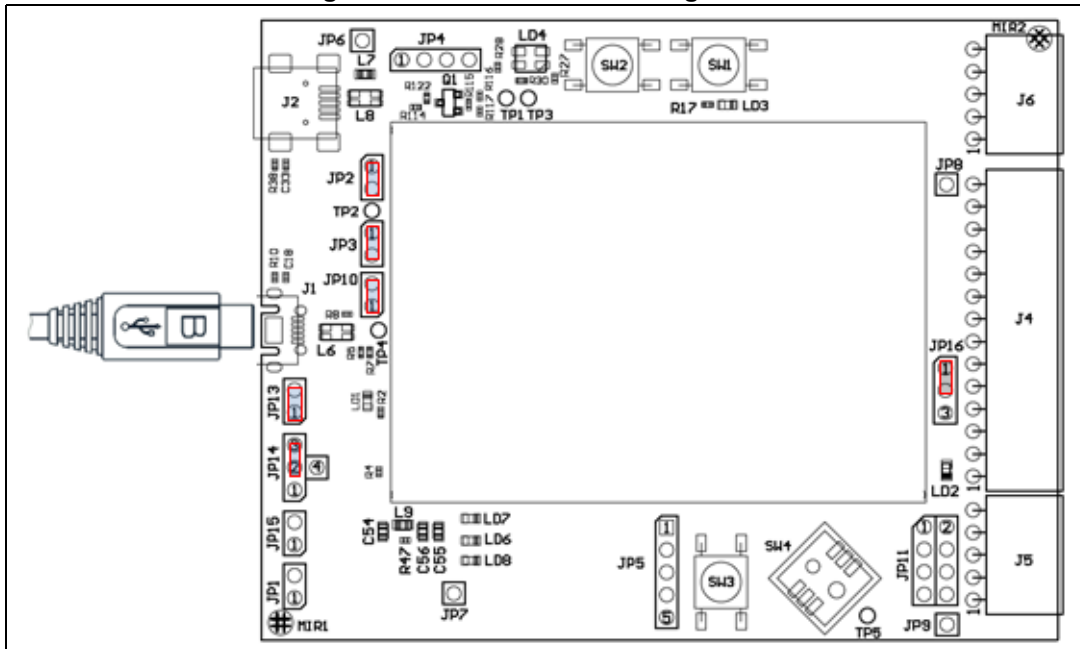


Table 2. Jumpers configuration

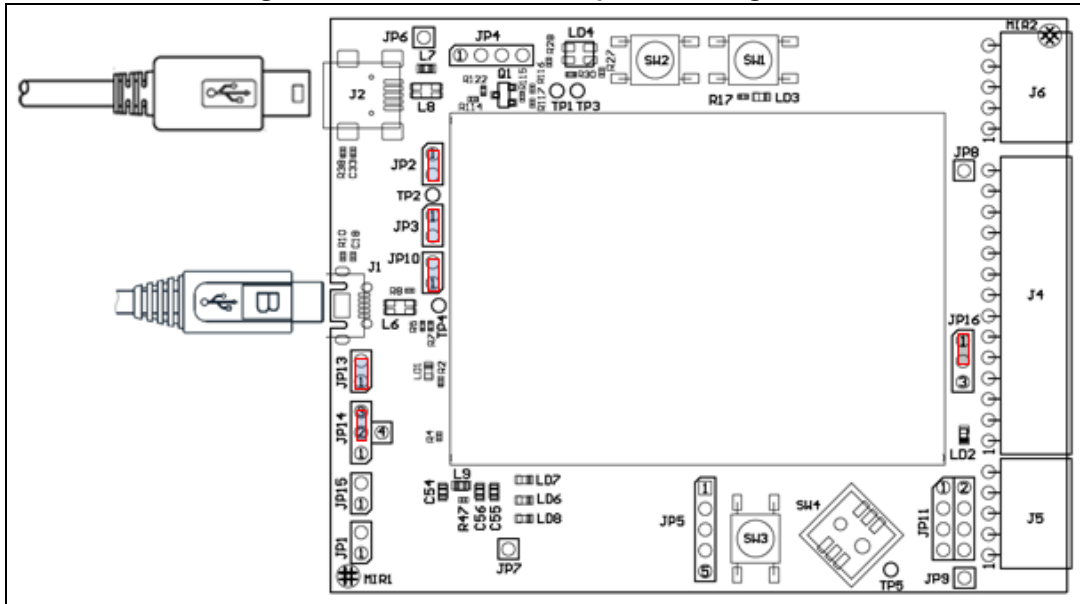
Connector	Position	Description
JP2	Closed 1-2	ST link UART debug features
JP3		
JP10		
JP13		
JP14	Closed 2-3	Card Powered by micro USB
JP16	Closed 1-2	Board powering special feature

4.3 MB1396 software development configuration

This section describes the MB1396 software development configuration and the USB connection when the embedded ST link is used.

The J1 USB micro connector provides the ST23R3916 powering, the J2 USB mini provides the link for the data exchange between the board and the computer.

Figure 6. MB1396 SW development configuration



5 MB1414 hardware

5.1 ST25R3916

The ST25R3916 is directly connected to the filtered 5 V USB supply. There are additional supply filtering components placed close to the NFC/HF reader IC.

During layout all decoupling capacitors have been placed as close as possible to the ST25R3916 chip.

To demonstrate the capacitive wake-up feature, two capacitive sensing electrodes are placed on the PCB.

For SPI cross-connecting another reader PCB, serial resistors can be removed and CN100 used.

By default, the SPI is the firmware and hardware access bus. The I2C bus can be used instead by changing J200, J201, J202, J203, J204 and J205.

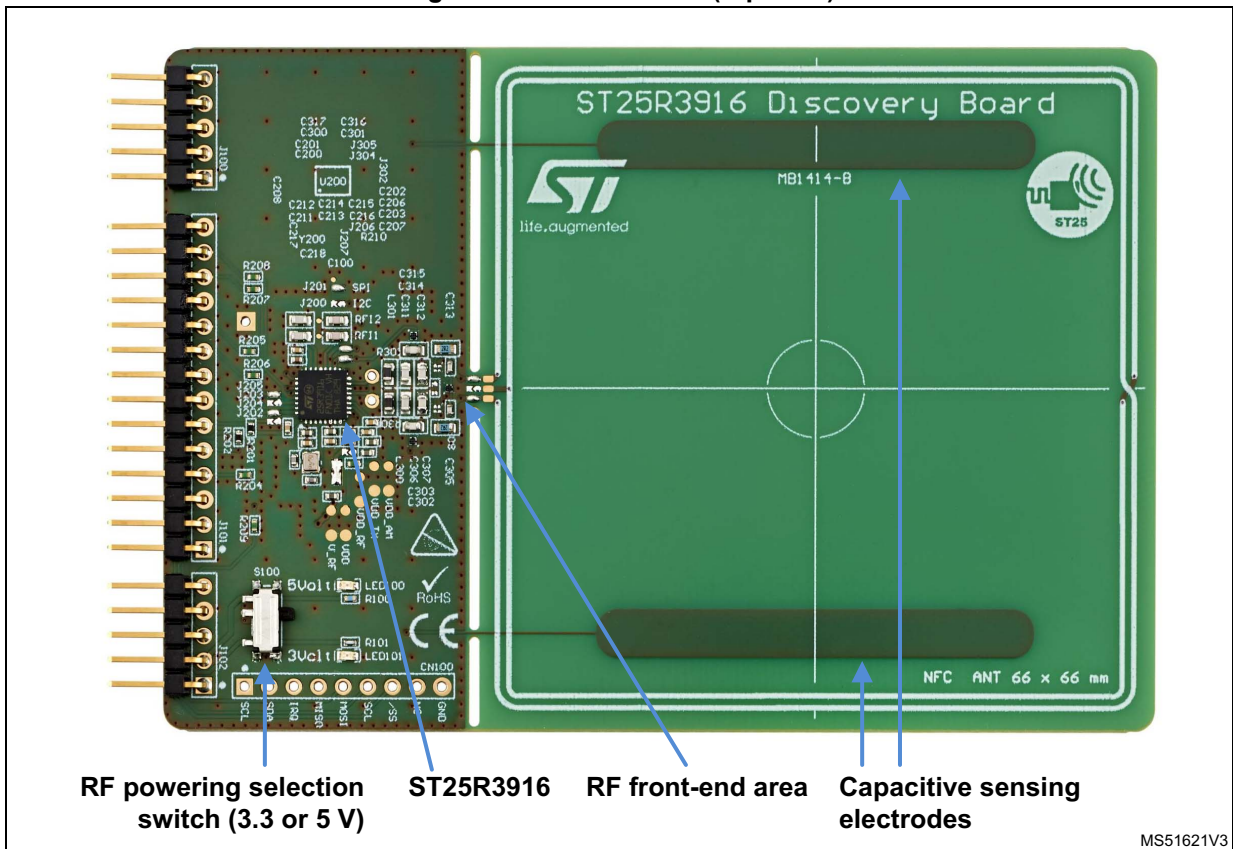
J206 makes it possible to bypass the internal V_{DD_RF} / V_{DD_AM} regulators when an output current higher than 350 mA needs to be supported.

5.2 Antenna and matching network components

This board contains the matching network and the automatic antenna tuning capacitors based on varicap.

5.3 Board layout

Figure 7. MB1414 board (top view)



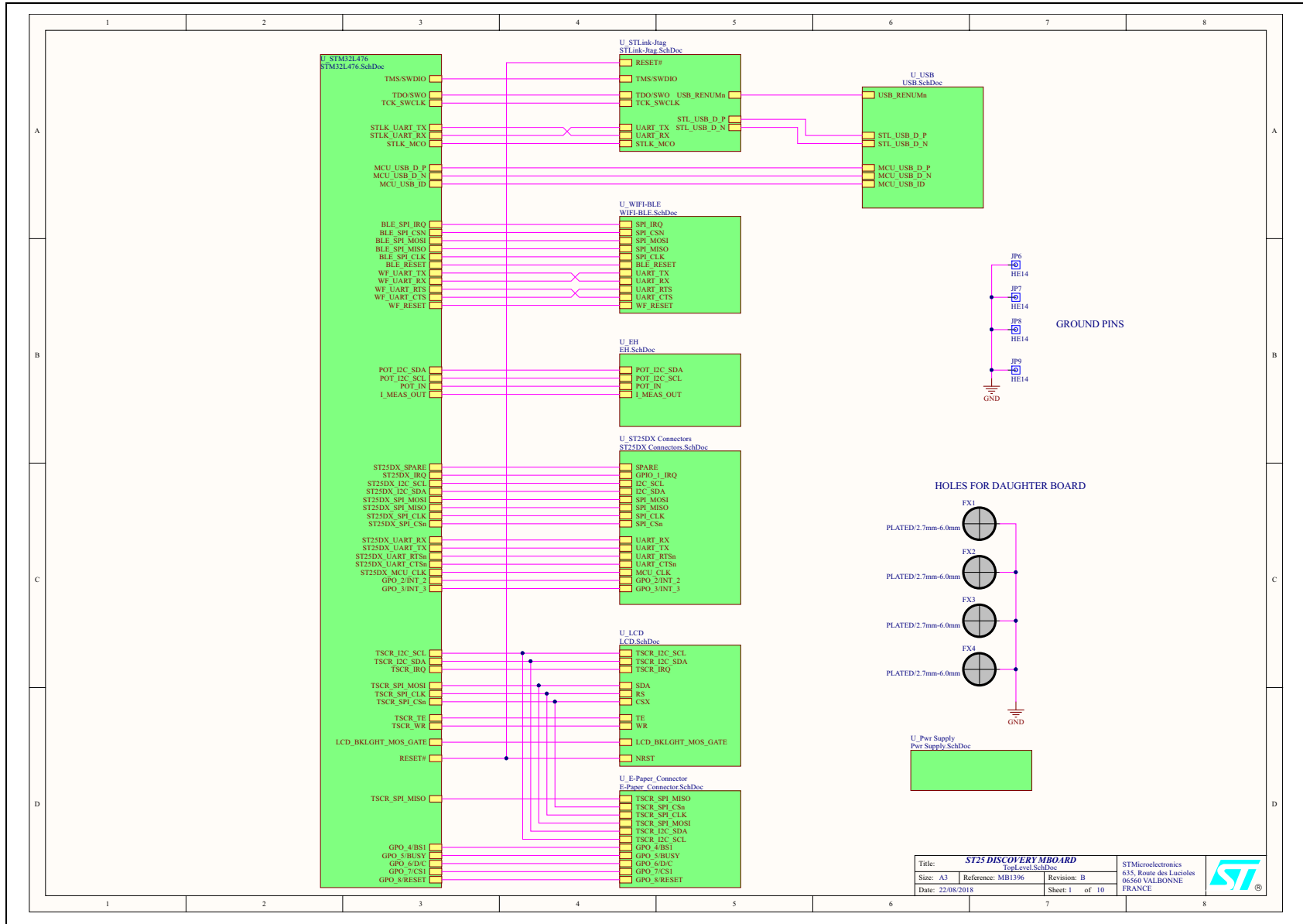
6 Schematics

This section contains the schematics for the two boards:

- those for the MB1396 MCU motherboard (figures 9 to 18) include the microcontroller needed to operate the NFC reader IC
- the MB1414 ST25R3916 daughter board (figures 19 to 21) is connected to the ST25_Discovery_Mboard motherboard.

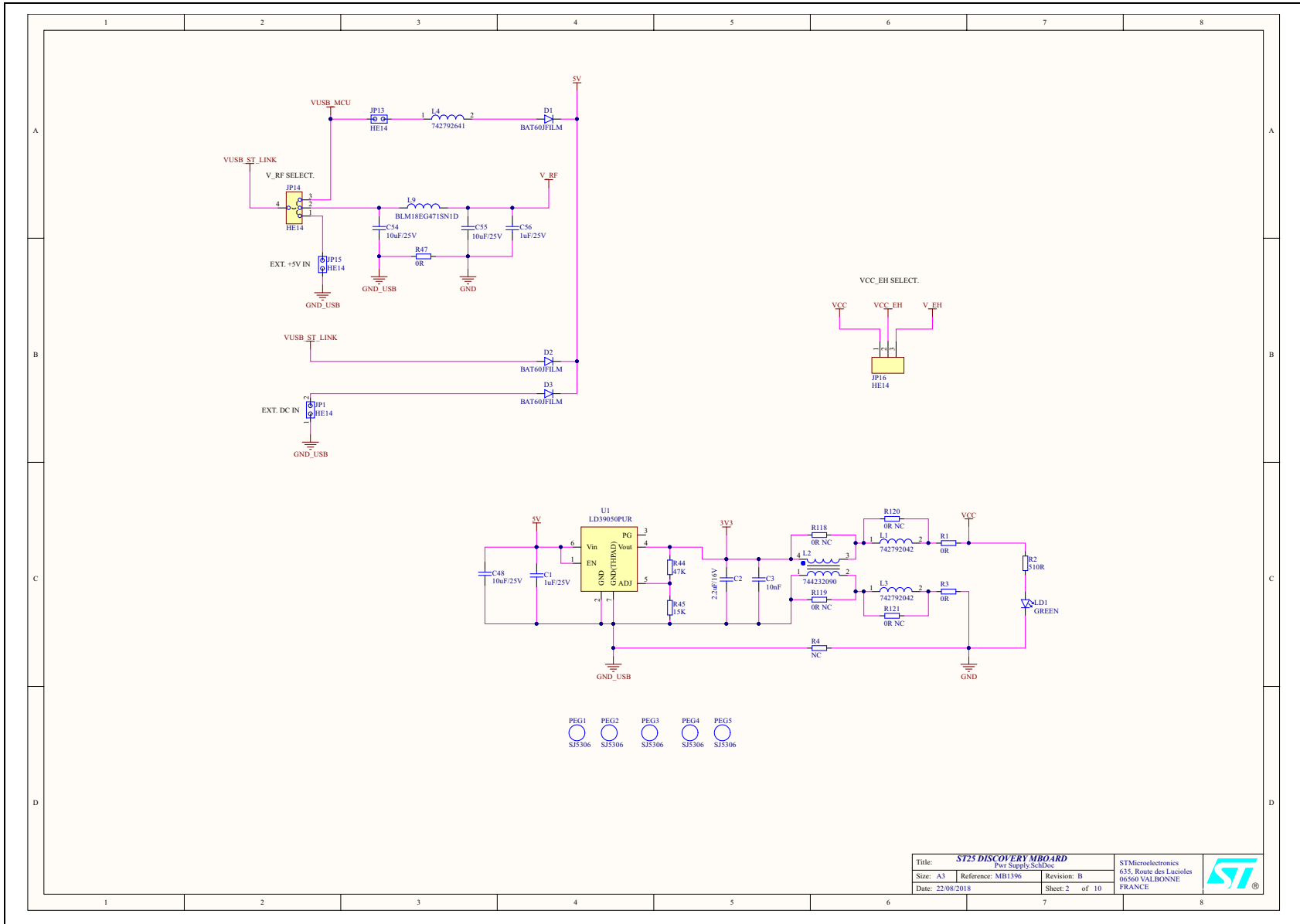


Figure 9. MB1396 - Overview



Title: ST25 DISCOVERY MBOARD TopLevel.SchDoc			
Size: A3	Reference: MB1396	Revision: B	
Date: 22/08/2018	Sheet: 1 of 10		
STMicroelectronics 635, Route des Lucioles 06560 VALBONNE FRANCE			

Figure 10. MB1396 - Power

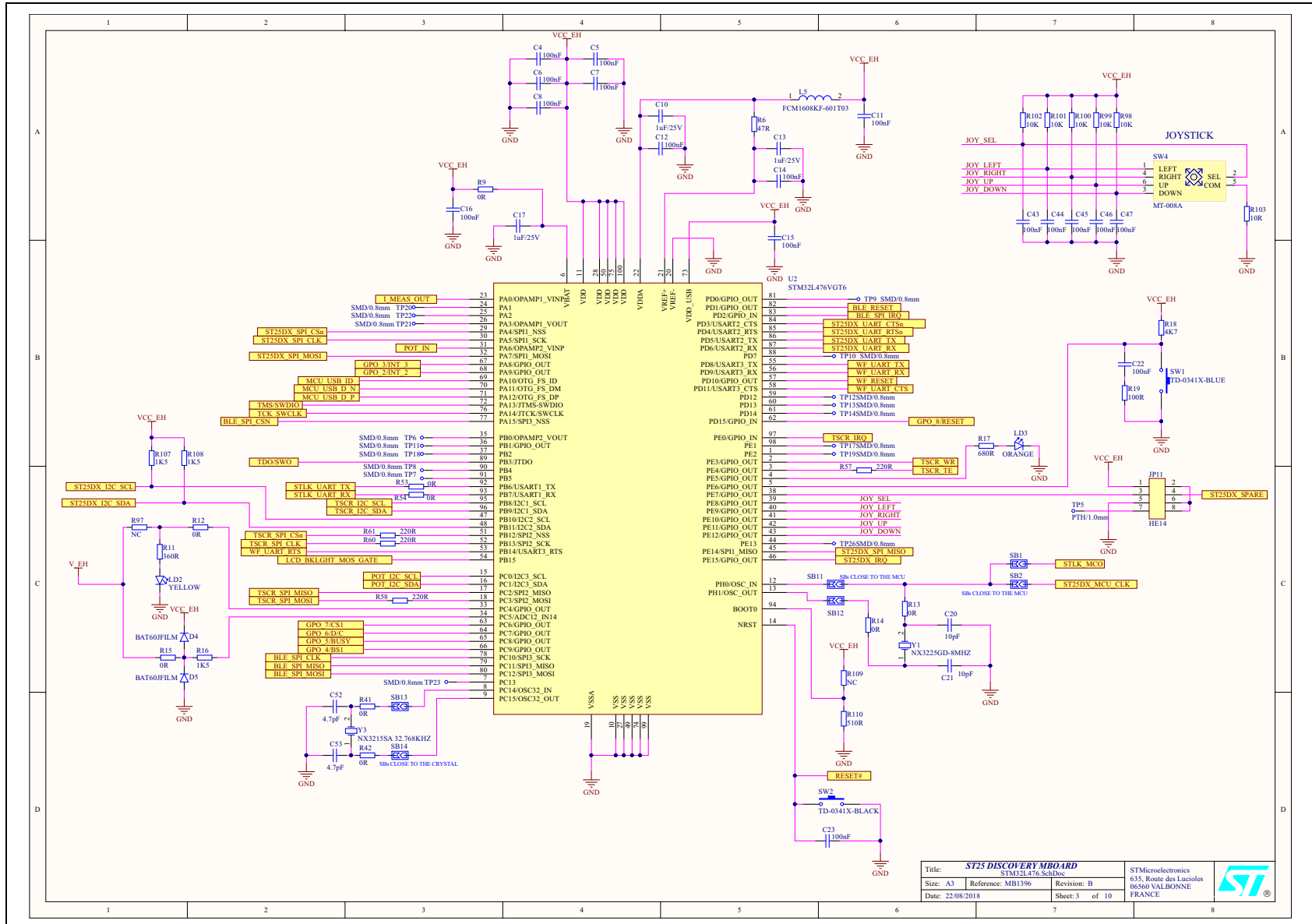


Title: ST25 DISCOVERY MBOARD Pwr Supply SchDoc		STMicroelectronics 635, Route des Lucioles 06560 VALBONNE FRANCE	
Size: A3	Reference: MB1396	Revision: B	Sheet: 2 of 10
Date: 22/08/2018			





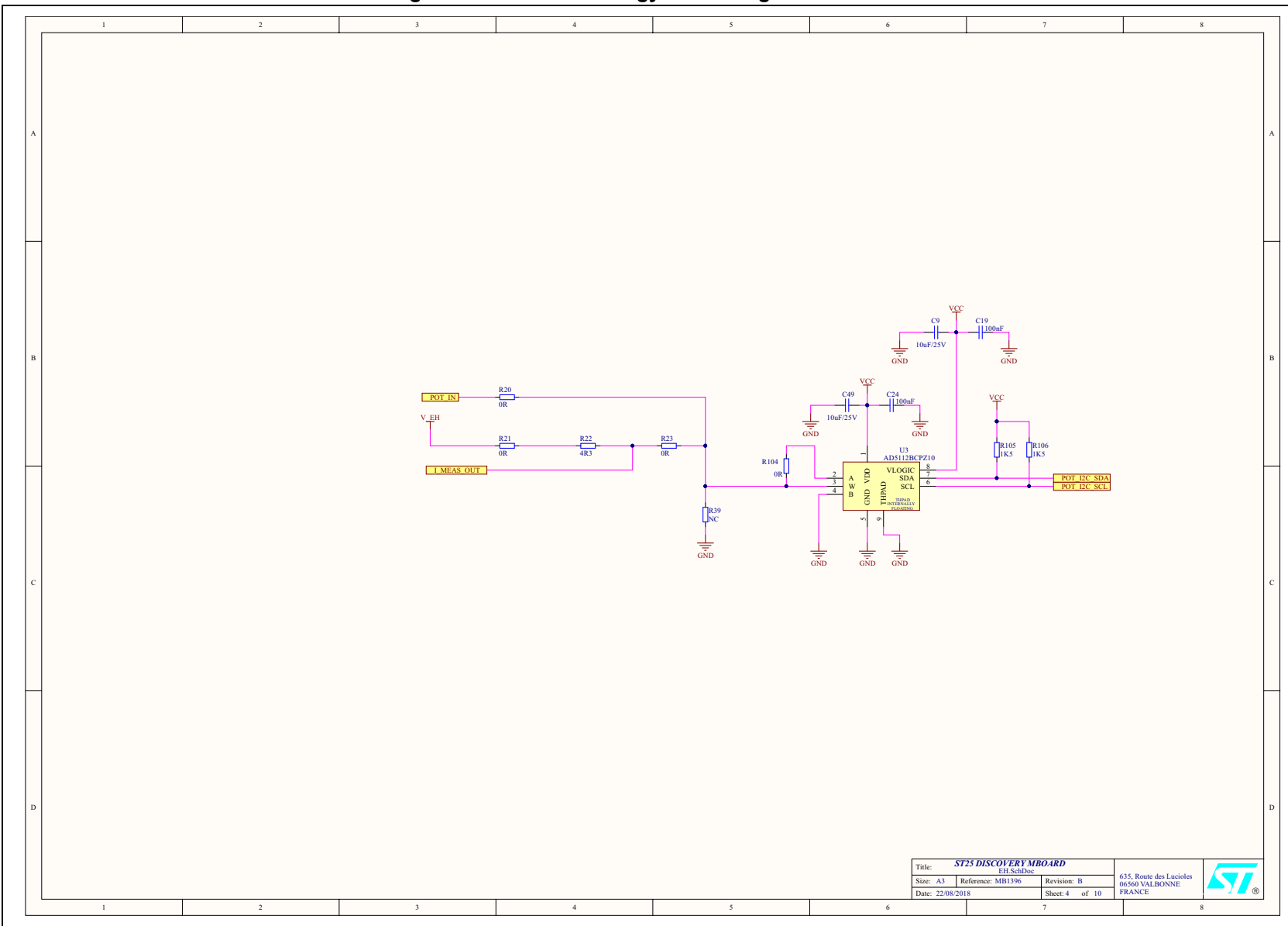
Figure 11. MB1396 - MCU



Title: ST25 DISCOVERY MBOARD		STMicroelectronics	
Reference: MB1396		635, Route des Lucioles	
Date: 22/08/2018	Revision: B	06560 VALBONNE	
	Sheet: 3 of 10	FRANCE	



Figure 12. MB1396 - Energy harvesting measurement

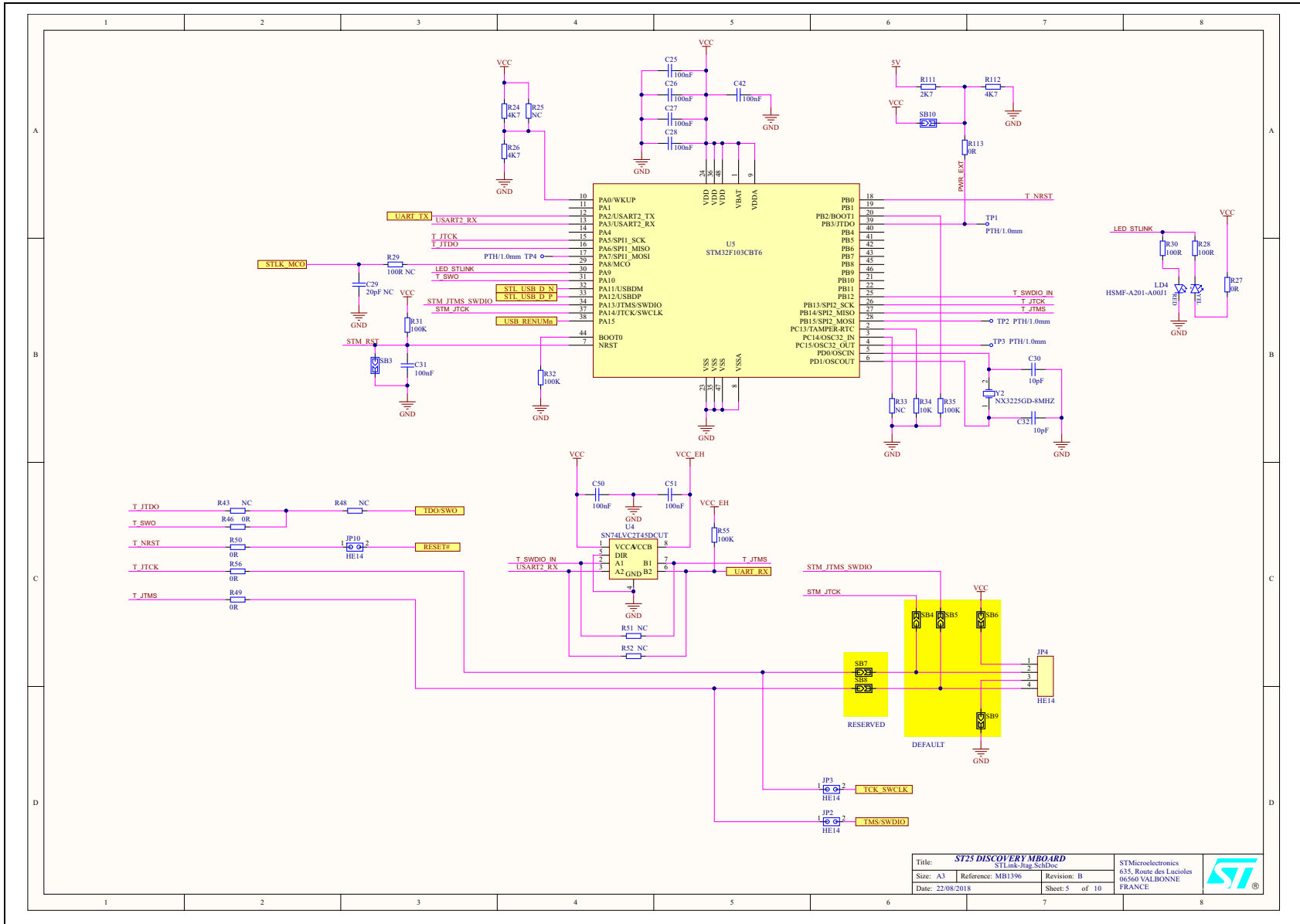


Title: ST25 DISCOVERY MBOARD		
EH_SchDoc		
Size: A3	Reference: MB1396	Revision: B
Date: 22/08/2018		Sheet: 4 of 10

 635, Route des Lucioles
 06560 VALBONNE
 FRANCE

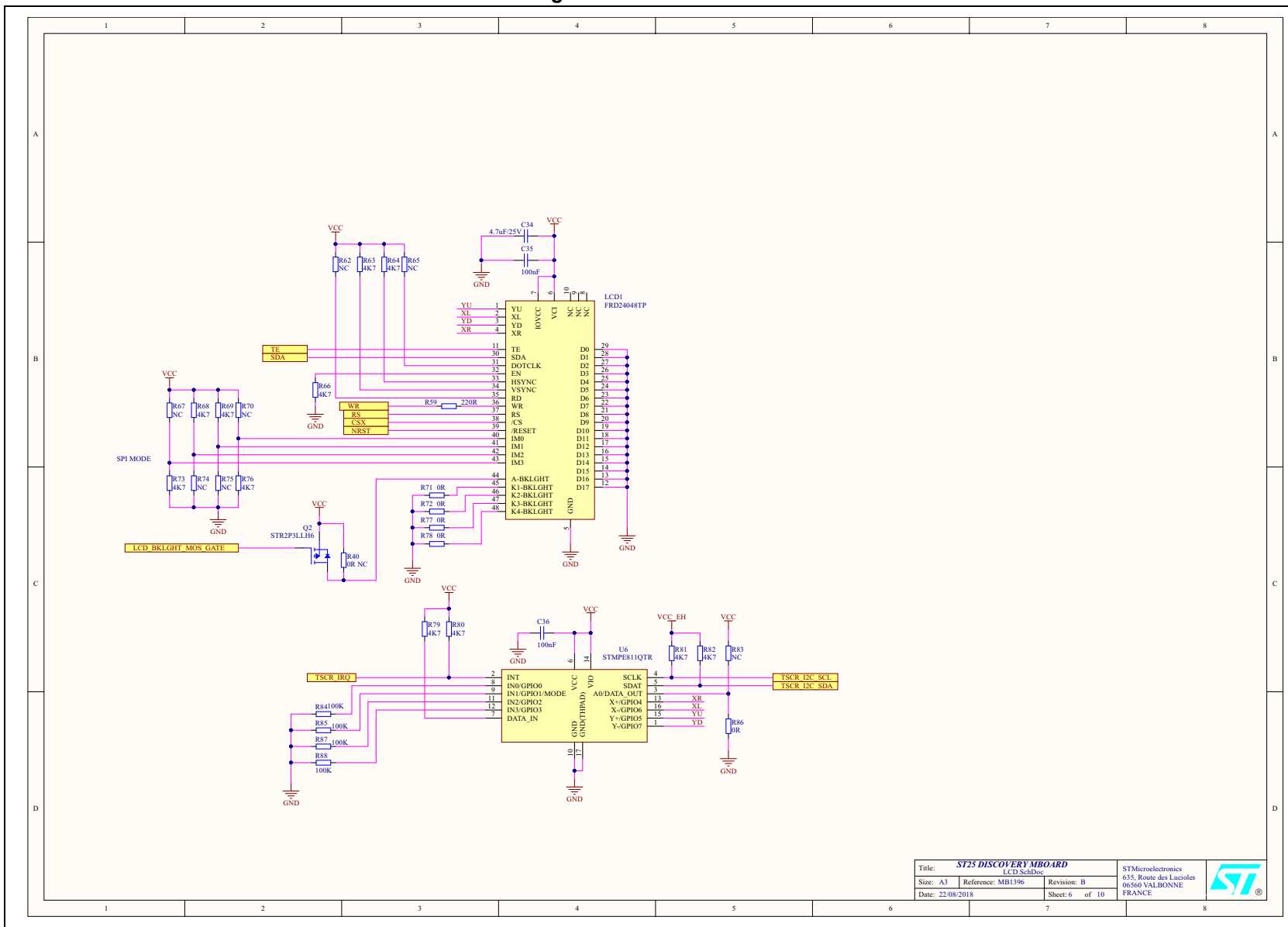



Figure 13. MB1396 - ST Link - JTAG



Title: ST25 DISCOVERY MBOARD			
STLink-Flag_SchDoc			
Size: A3	Reference: MB1396		Revision: B
Date: 22/08/2018	Sheet: 5 of 10		STMicroelectronics 635, Route des Lucioles 06560 VALBONNE FRANCE

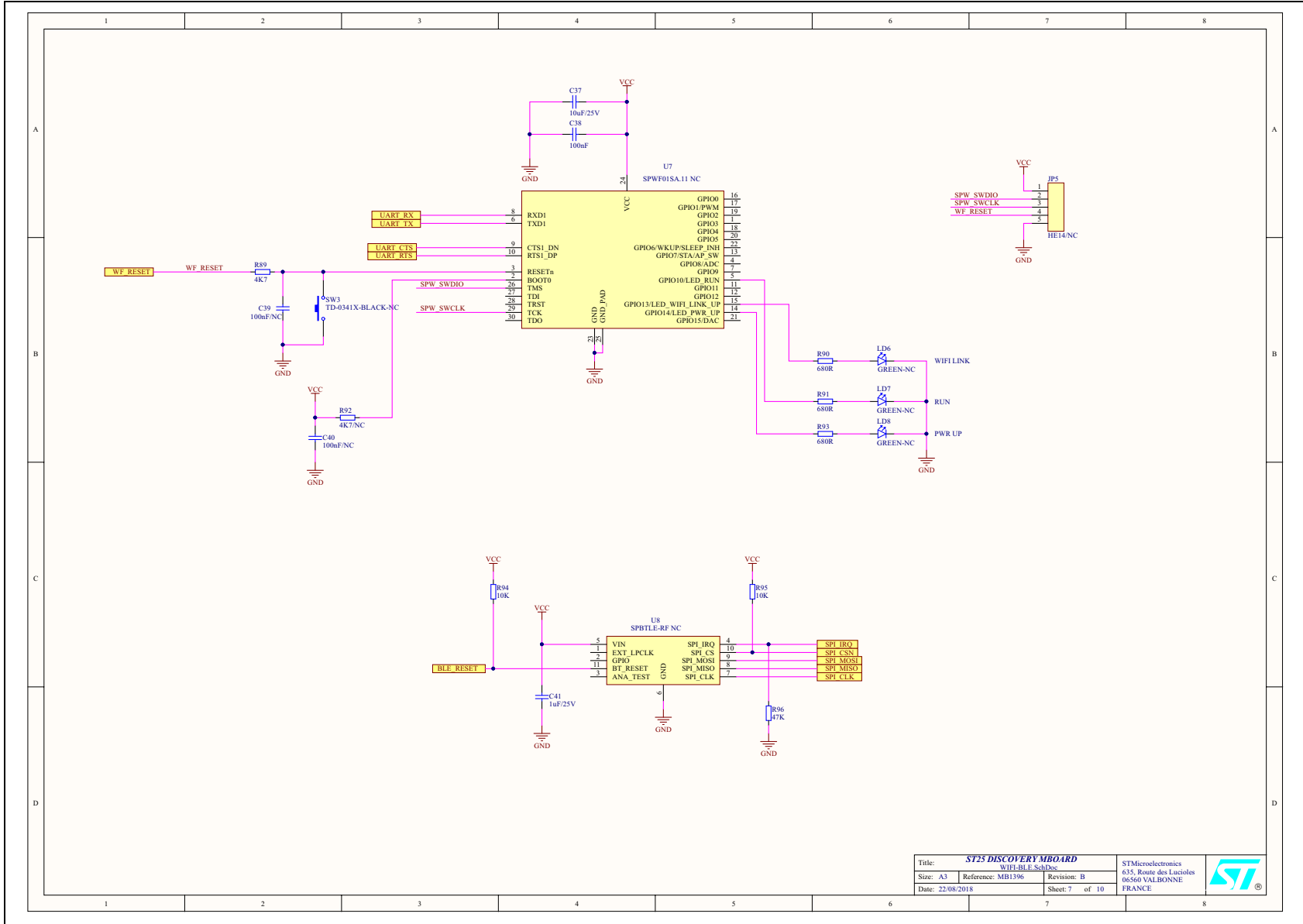
Figure 14. MB1396 - LCD



Title: ST25 DISCOVERY MBOARD		STMicroelectronics		
LCD.SchDoc		635, Route des Lucioles		
Size: A3	Reference: MB1396	Revision: B	06560 VALBONNE	
Date: 22/08/2018		Sheet: 6 of 10	FRANCE	

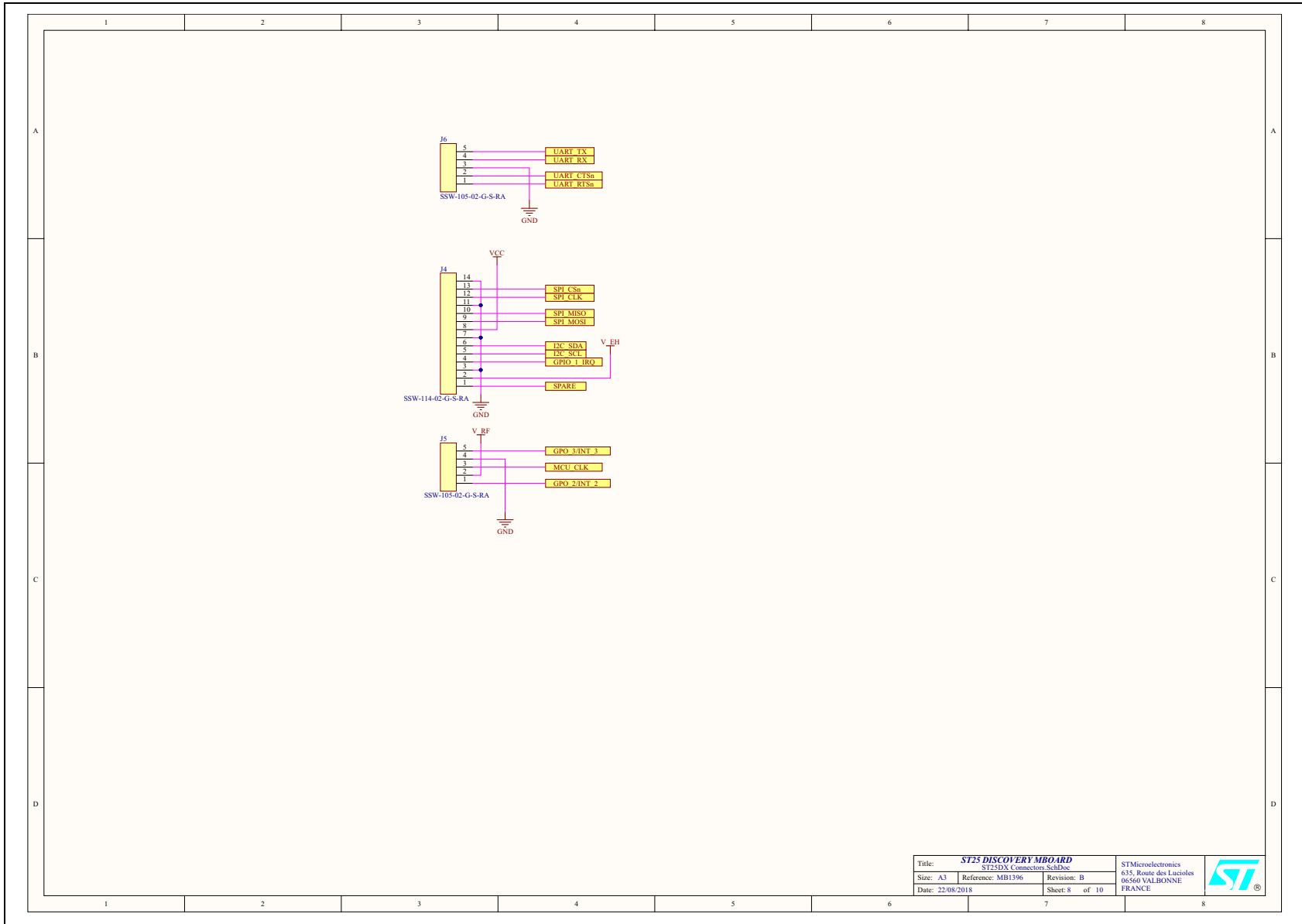


Figure 15. MB1396 - BLE and WiFi® modules



Title: ST25 DISCOVERY MBOARD			STMicroelectronics 635, Route des Lucioles 06560 VALBONNE FRANCE	
Size: A3	Reference: MB1396	Revision: B		
Date: 22/08/2018		Sheet: 7 of 10		

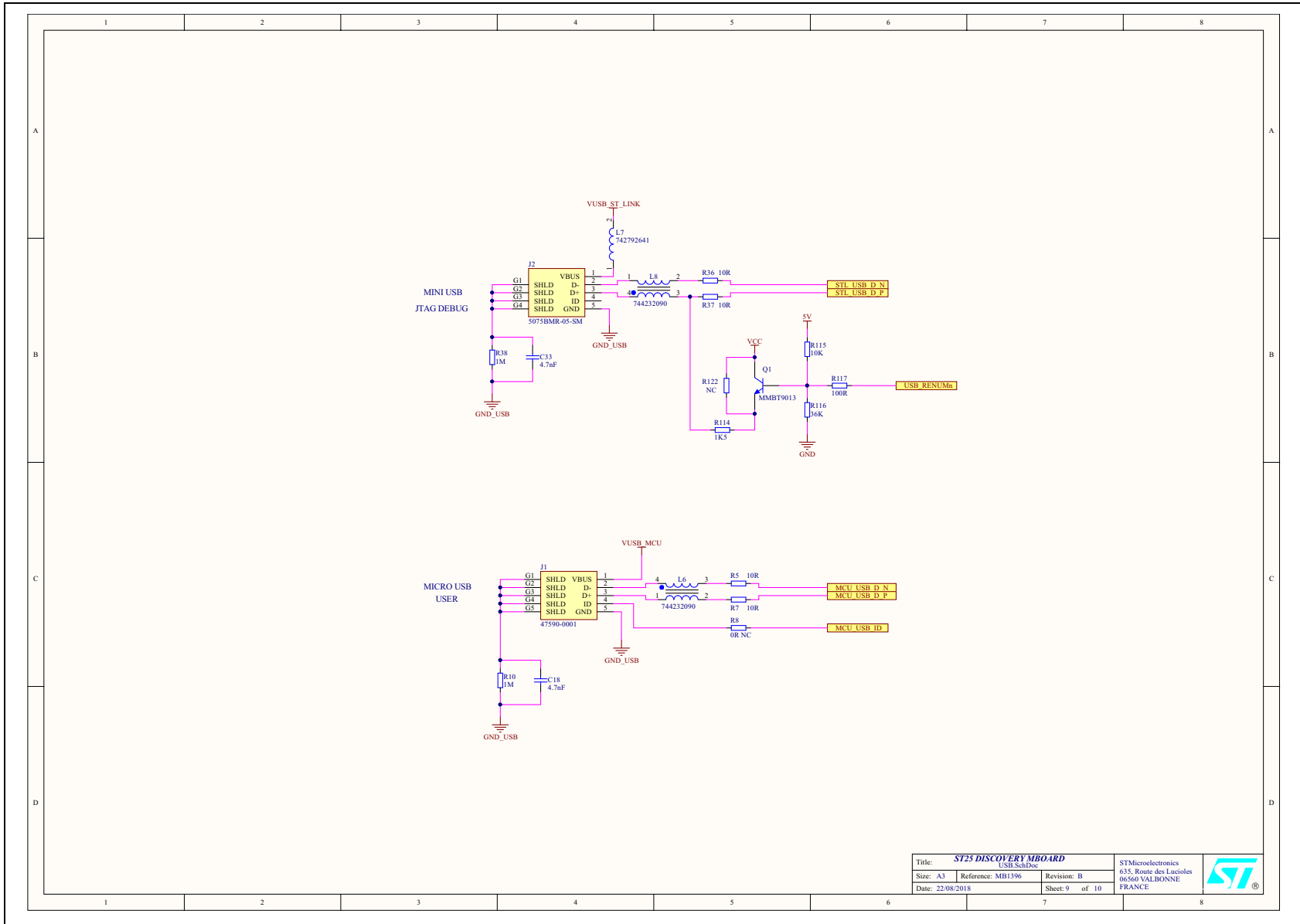
Figure 16. MB1396 - Connectors



Title: ST25 DISCOVERY MBOARD		STMicroelectronics		
Size: A3		Reference: MB1396	Revision: B	
Date: 22/08/2018	Sheet: 8 of 10		635, Route des Lucioles 06560 VALBONNE FRANCE	



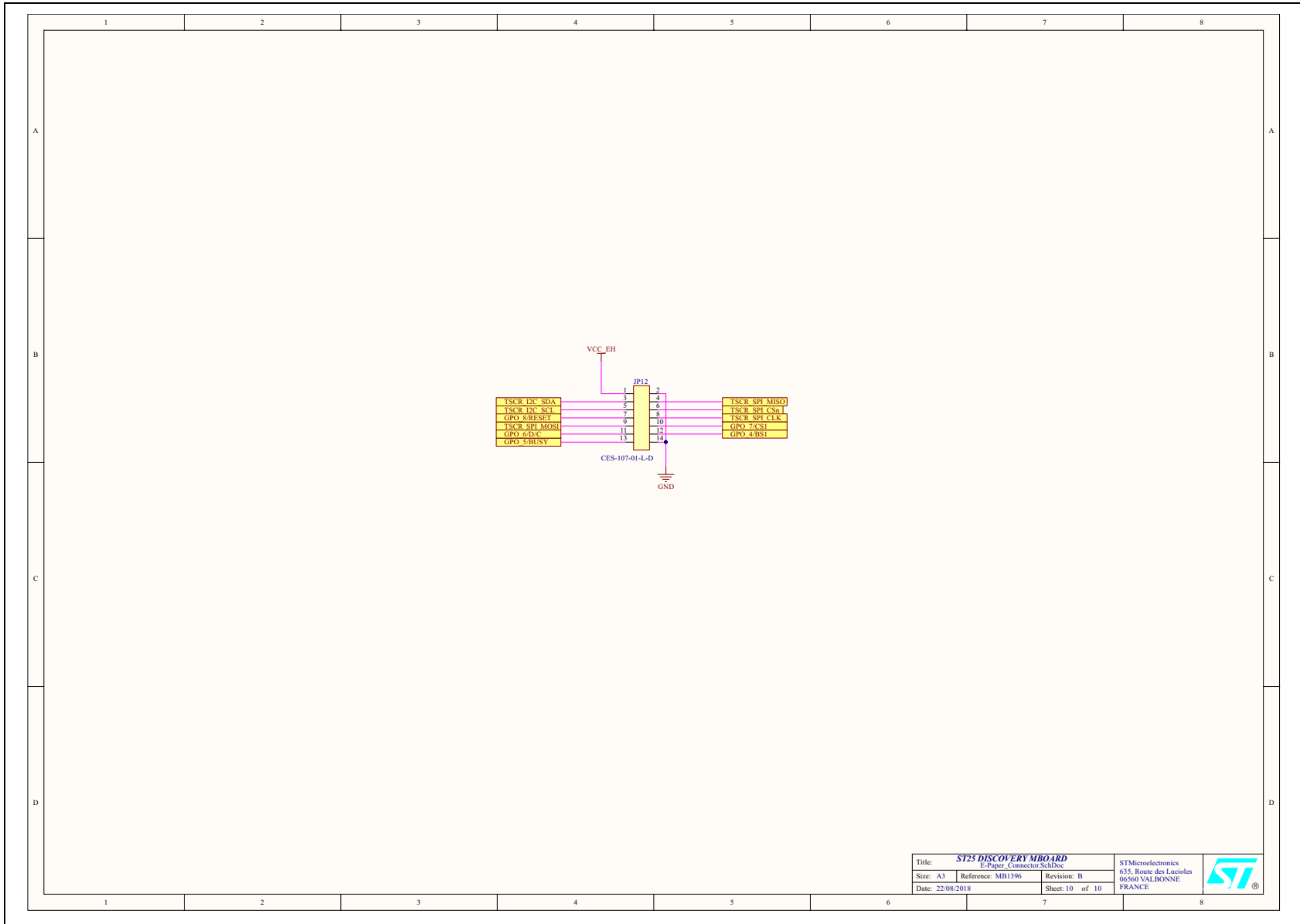
Figure 17. MB1396 - USB



Title: ST25 DISCOVERY MBOARD		USB_SchDoc		STMicroelectronics	
Size: A3	Reference: MB1396	Revision: B	635, Route des Lucioles		
Date: 22/08/2018	Sheet: 9 of 10		06560 VALBONNE		
				FRANCE	



Figure 18. MB1396 - Epaper connector



Title: ST25 DISCOVERY MBOARD E-Paper Connector SchDoc		STMicroelectronics 635, Route des Lucioles 06560 VALBONNE FRANCE		
Size: A3	Reference: MB1396	Revision: B		
Date: 22/08/2018	Sheet: 10 of 10			



Figure 19. MB1414 - Connectors

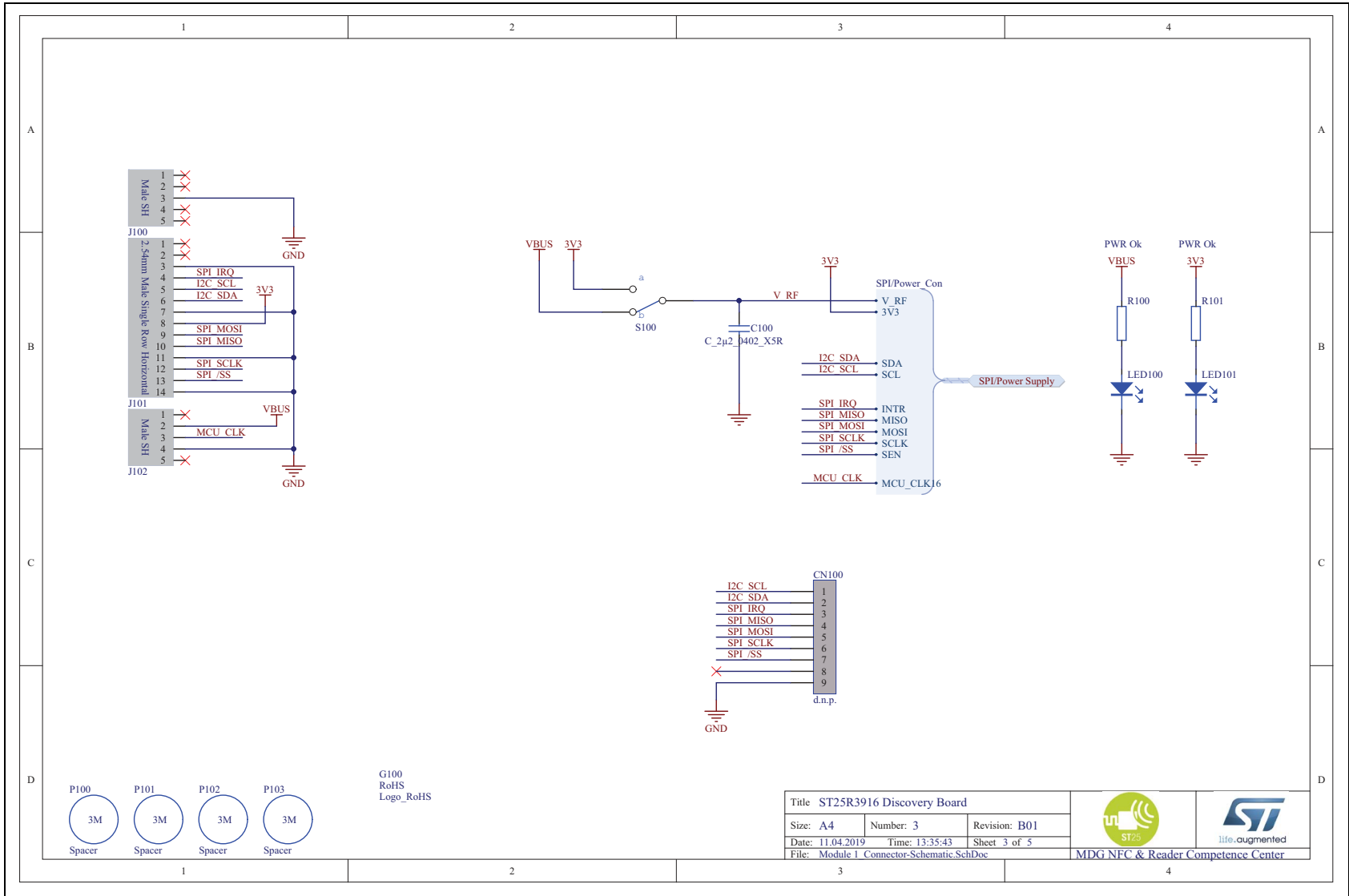
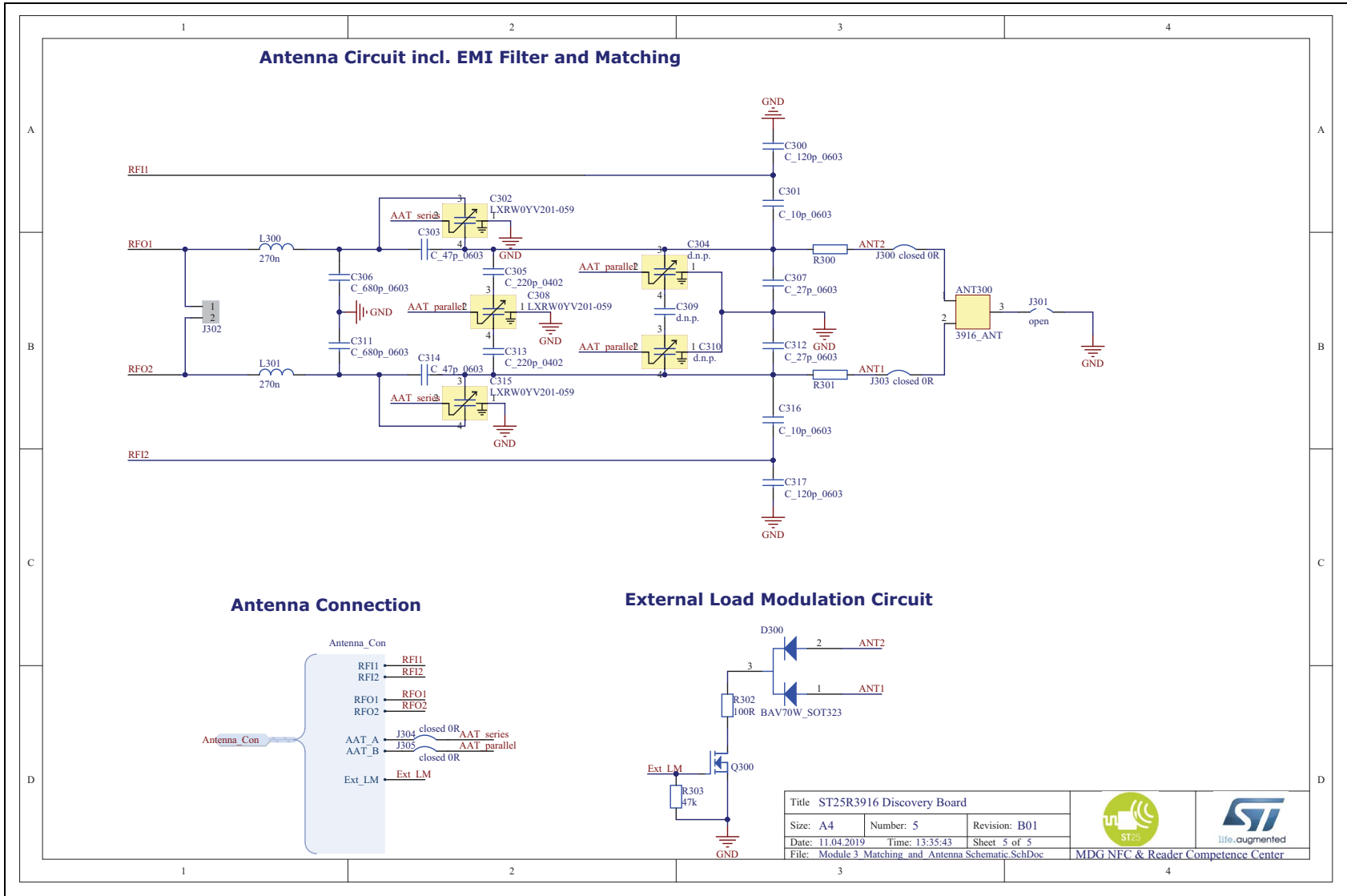




Figure 21. MB1414 - Antenna and external load



7 Federal Communications Commission (FCC) and Industry Canada (IC) compliance statements

7.1 FCC Compliance Statement

7.1.1 Part 15.19

This device complies with Part 15 of the FCC Rules. Operation is subject to the following two conditions: (1) this device may not cause harmful interference, and (2) this device must accept any interference received, including interference that may cause undesired operation.

7.1.2 Part 15.21

Any changes or modifications to this equipment not expressly approved by STMicroelectronics may cause harmful interference and void the user's authority to operate this equipment.

7.1.3 FCC ID

FCC ID: YCPR3916DB1

7.2 Formal notices required by the Industry Canada ("IC")

7.2.1 Compliance Statement

This device complies with Industry Canada licence-exempt RSS standard(s). Operation is subject to the following two conditions: (1) this device may not cause interference, and (2) this device must accept any interference, including interference that may cause undesired operation.

7.2.2 Déclaration de Conformité

Le présent appareil est conforme aux CNR d'Industrie Canada applicables aux appareils radio exempts de licence. L'exploitation est autorisée aux deux conditions suivantes: (1) l'appareil ne doit pas produire de brouillage, et (2) l'utilisateur de l'appareil doit accepter tout brouillage radioélectrique subi, même si le brouillage est susceptible d'en compromettre le fonctionnement.

7.2.3 IC ID

IC ID: 8976A-R3916DB1

8 Revision history

Table 3. Document revision history

Date	Revision	Changes
07-Dec-2018	1	Initial release.
14-May-2019	2	Changed document classification, from ST restricted to public. Updated Figure 1: ST25R3916-DISCO board (top view) , Figure 7: MB1414 board (top view) , Figure 8: MB1414 board (bottom view) , Figure 19: MB1414 - Connectors , Figure 20: MB1414 - ST25R3916 and Figure 21: MB1414 - Antenna and external load .
19-Nov-2019	3	Updated Section 7.2.3: IC ID .
02-Dec-2019	4	Updated Section 7.2.3: IC ID . Updated Figure 8: MB1414 board (bottom view) .

IMPORTANT NOTICE – PLEASE READ CAREFULLY

STMicroelectronics NV and its subsidiaries (“ST”) reserve the right to make changes, corrections, enhancements, modifications, and improvements to ST products and/or to this document at any time without notice. Purchasers should obtain the latest relevant information on ST products before placing orders. ST products are sold pursuant to ST’s terms and conditions of sale in place at the time of order acknowledgement.

Purchasers are solely responsible for the choice, selection, and use of ST products and ST assumes no liability for application assistance or the design of Purchasers’ products.

No license, express or implied, to any intellectual property right is granted by ST herein.

Resale of ST products with provisions different from the information set forth herein shall void any warranty granted by ST for such product.

ST and the ST logo are trademarks of ST. For additional information about ST trademarks, please refer to www.st.com/trademarks. All other product or service names are the property of their respective owners.

Information in this document supersedes and replaces information previously supplied in any prior versions of this document.

© 2019 STMicroelectronics – All rights reserved