

## ***AFE5803EVM (Revision E ) Evaluation Module***

This document assists users in evaluating the AFE5803 highly integrated analog front-end devices through the use of the AFE5803EVM Evaluation Module. Included are setup instructions, printed-circuit board art, bill of materials, and schematics.

### **Contents**

|            |  |    |
|------------|--|----|
| 1          | Overview .....   | 2  |
| 2          | Default Configuration .....                                | 2  |
| 3          | Software Installation and Operation .....                  | 3  |
| 4          | Test Setup .....   | 4  |
| 5          | Power Up AFE5803 .....                                     | 5  |
| 6          | Launch AFE5803 GUI .....                                   | 6  |
| 7          | Launch TSW1400 GUI .....                                   | 7  |
| 8          | Test AFE5803 .....   | 8  |
|            | 8.1 Step 1: Time Domain .....                              | 8  |
|            | 8.2 Step 2: Single Tone FFT .....                          | 11 |
| 9          | External ADC Sampling Clock .....                          | 12 |
| 10         | External Vcntl .....                                       | 14 |
| 11         | Board Configuration .....                                  | 15 |
|            | 11.1 Input/Output, Power Supply, and USB .....             | 15 |
|            | 11.2 ADC Clock .....                                       | 16 |
|            | 11.3 Vcntl Control Input .....                             | 17 |
|            | 11.4 LEDs .....  | 18 |
|            | 11.5 Miscellaneous Test Points .....                       | 19 |
| 12         | EVM Printed-Circuit Board Layouts and Schematics .....     | 20 |
|            | 12.1 Schematics .....                                      | 26 |
| 13         | Bill of Materials .....                                    | 35 |
| Appendix A | High Speed Data Converter Pro (HSDCPro) Installation ..... | 39 |

### **List of Figures**

|    |   |    |
|----|---|----|
| 1  | AFE5803EVM Basic Configuration .....                          | 3  |
| 2  | HW Setup With Connection Between TSW1400EVM and AFE5803 ..... | 4  |
| 3  | Default Conditions Screen .....                               | 6  |
| 4  | User Interface: Single FFT Format .....                       | 11 |
| 5  | External ADC Sampling Clock Configuration .....               | 12 |
| 6  | External Vcntl Configuration .....                            | 14 |
| 7  | I/O, PWR, and USB Connector .....                             | 15 |
| 8  | AFE5803EVM Jumper Locations .....                             | 16 |
| 9  | Vcntl .....   | 17 |
| 10 | AFE5803EVM LED Location .....                                 | 18 |
| 11 | AFE5803EVM Test Point Locations .....                         | 19 |
| 12 | Top Layer - Signal .....                                      | 20 |
| 13 | Second Layer - Ground .....                                   | 21 |
| 14 | Third Layer - Power .....                                     | 22 |
| 15 | Fourth Layer - Signal .....                                   | 23 |

|    |  |    |
|----|--|----|
| 16 | Fifth Layer - Ground .....                         | 24 |
| 17 | Bottom Layer - Signal.....                         | 25 |
| 18 | Schematic 1 of 9 .....                             | 26 |
| 19 | Schematic 2 of 9 .....                             | 27 |
| 20 | Schematic 3 of 9 .....                             | 28 |
| 21 | Schematic 4 of 9 (Not applicable to AFE5803) ..... | 29 |
| 22 | Schematic 5 of 9 .....                             | 30 |
| 23 | Schematic 6 of 9(Not applicable to AFE5803) .....  | 31 |
| 24 | Schematic 7 of 9 .....                             | 32 |
| 25 | Schematic 8 of 9(Not applicable to AFE5803) .....  | 33 |
| 26 | Schematic 9 of 9 .....                             | 34 |
| 27 | HSDCPro Install (Begin).....                       | 39 |
| 28 | HSDCPro Install (Install Directory).....           | 40 |
| 29 | HSDCPro Install (TI License Agreement) .....       | 41 |
| 30 | HSDCPro Install (NI License Agreement).....        | 42 |
| 31 | HSDCPro Install (Start Installation) .....         | 43 |
| 32 | HSDCPro Install (Installation Progress) .....      | 44 |
| 33 | HSDCPro Install (Installation Complete) .....      | 45 |
| 34 | HSDCPro Install (h) .....                          | 46 |
| 35 | HSDCPro Install .....                              | 46 |

#### List of Tables

|   |                                    |    |
|---|------------------------------------|----|
| 1 | Input/Output, Power, and USB ..... | 15 |
| 2 | PGATestMode, ADC Clock .....       | 16 |
| 3 | Vcntl.....                         | 17 |
| 4 | LED Indicators .....               | 18 |
| 5 | Test Points .....                  | 19 |
| 6 | Bill of Materials .....            | 35 |

## 1 Overview

This document is intended to guide users step-by-step through the AFE5803EVM Evaluation Module (EVM) setup and test . The EVM is shipped with a default configuration from the manufacturer. With this configuration, the onboard CMOS clock is used for a analog-to-digital converter sampling clock. No external clock generator is required. Users need to provide the input signal for measurement from a signal generator.

Detail explanation regarding the jumpers, connectors, and test points appear in [Section 11](#). The graphical user interface (GUI) can be downloaded from the TI Web site.

## 2 Default Configuration

[Figure 1](#) shows the default configuration of the EVM from the factory. The accompanying list identifies the basic components on the EVM board.

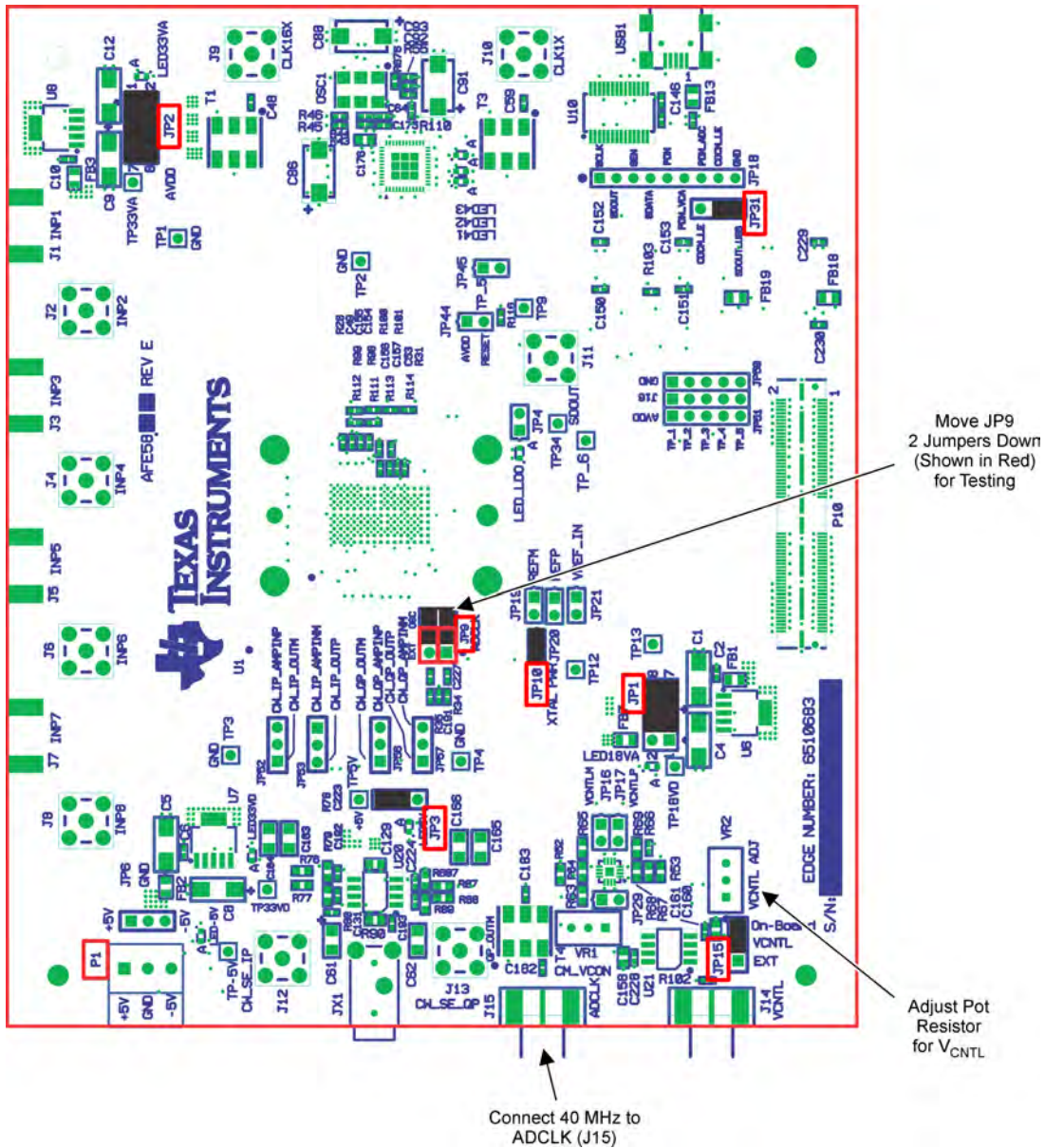

Figure 1. AFE5803EVM Basic Configuration

1. P1 – Power supplies connector.
2. JP1, JP2, and JP3 are set to enable 3.3-V, 1.8-V, and 5-V power supplies to device.
3. JP9: enables onboard CMOS clock.
4. JP10: Power supply for onboard CMOS clock oscillator.
5. JP15: Enables onboard VCNTL.
6. JP31 always set as Figure 1.

### 3 Software Installation and Operation

The AFE5803EVM GUI ([SLOC260](#)) can be downloaded from the TI Web site. Follow the directions in ReadMeFirst.pdf file to install GUI and device driver

## 4 Test Setup

Two EVMs are required to evaluate the AFE5803 device. The following illustration shows the exact setup of these two boards and external connectors. For the default configuration as shown in [Figure 1](#), it is unnecessary to have an external sampling clock and external Vcntl supply. The onboard CMOS clock and onboard Vcntl are used.

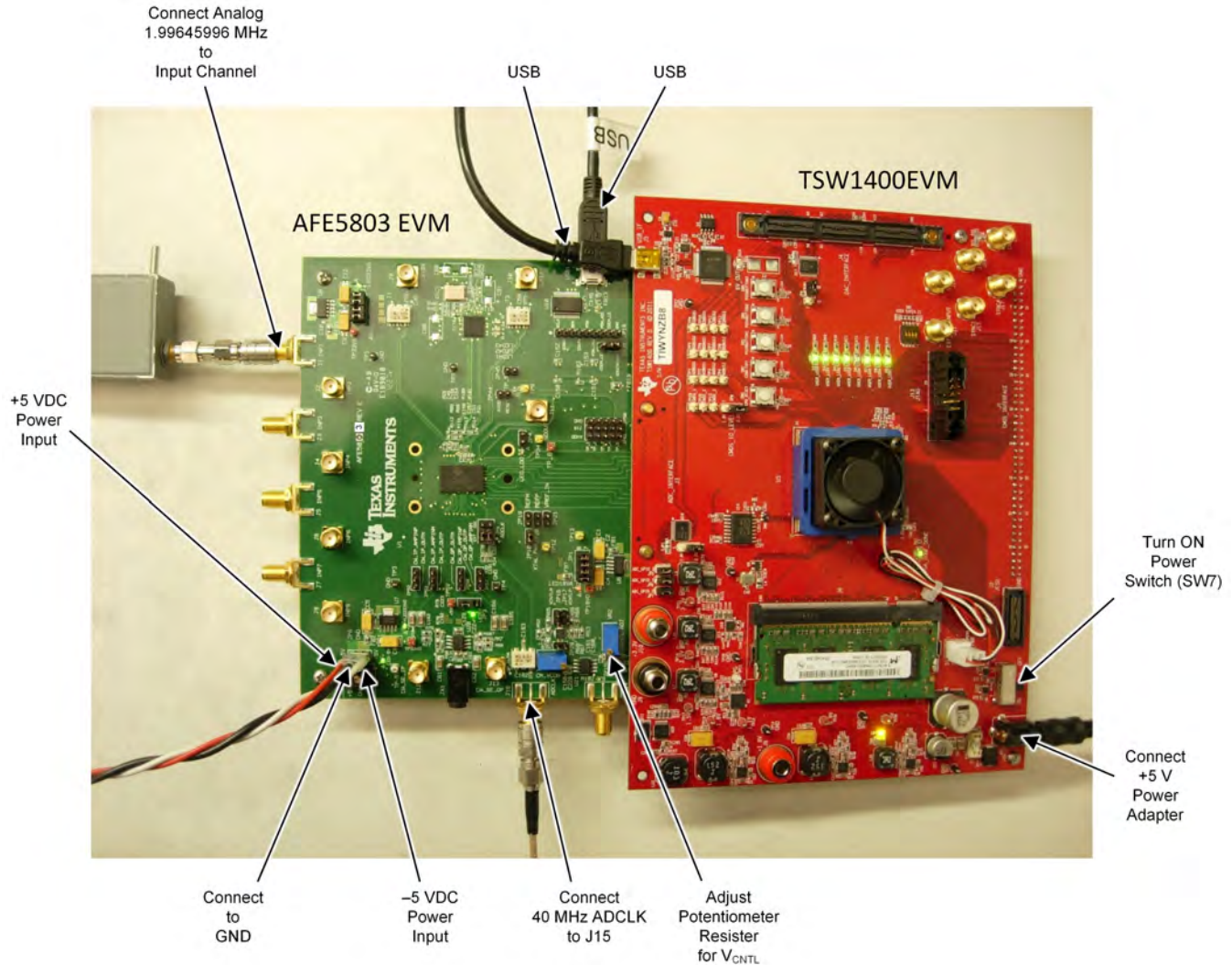

**Figure 2. HW Setup With Connection Between TSW1400EVM and AFE5803**

## 5 Power Up AFE5803

Power up the AFE5803EVM by applying +5 V and -5 V to the P1 connector. After power up is complete, four green LEDs and two red LEDs are turned on as shown in the following illustration.

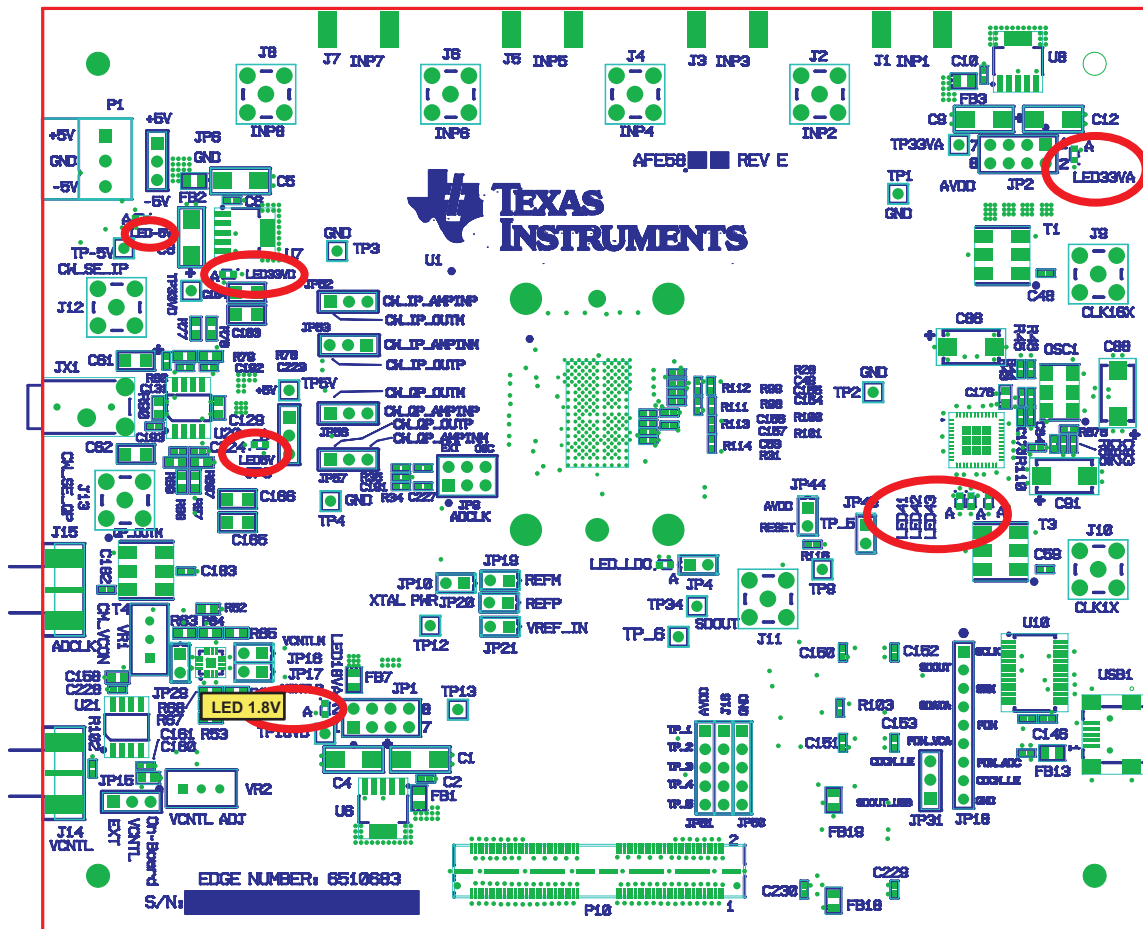

## 6 Launch AFE5803 GUI

Launch the AFE5803 graphic user interface (GUI), select the ADC page to observe the default condition.

Figure 3 shows the default conditions on the ADC page.

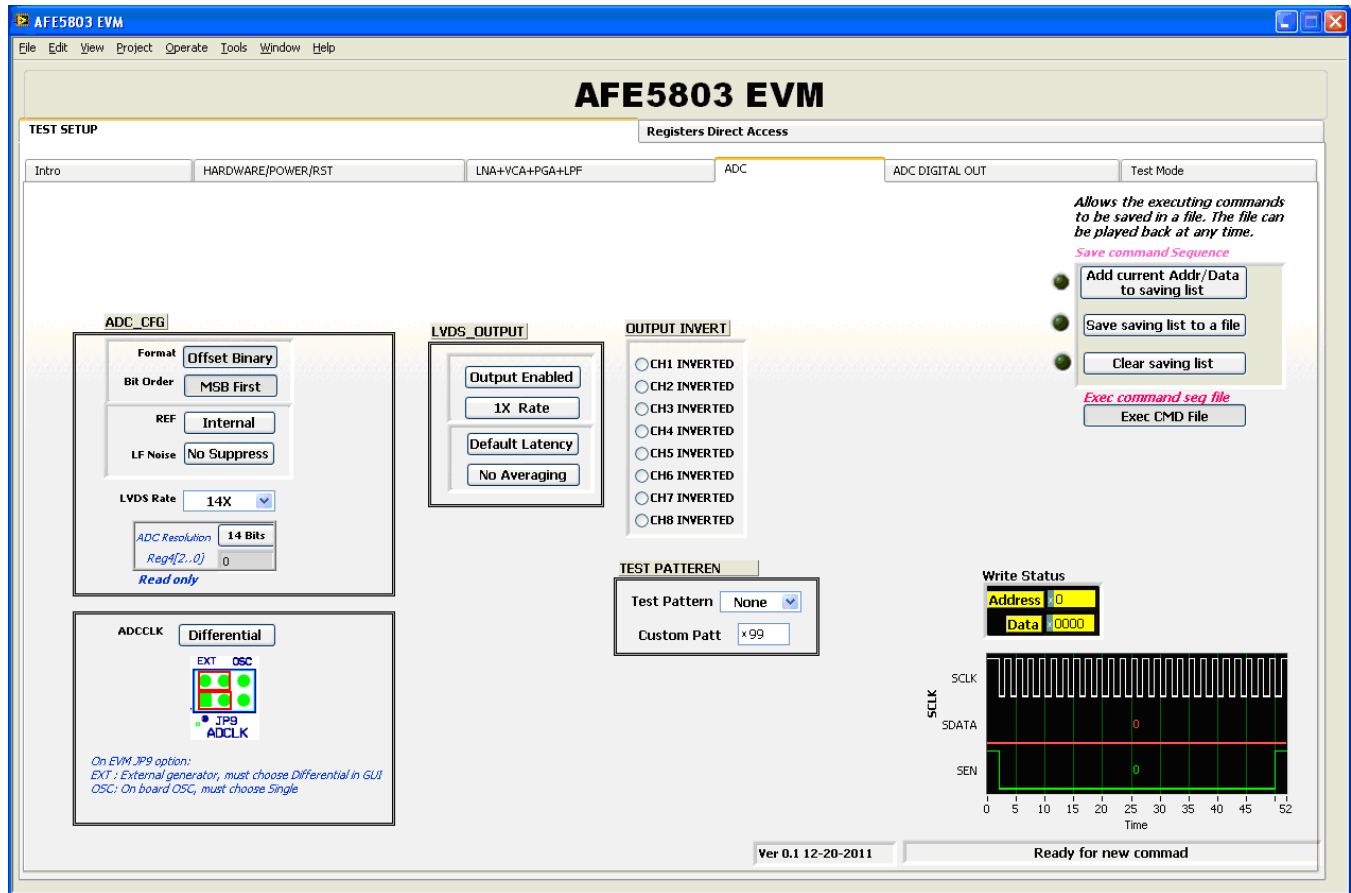

Figure 3. Default Conditions Screen

## 7 Launch TSW1400 GUI

Launch the TSW1400 GUI. For information on how to download this GUI see . The Message window displays the following message to indicate that the setup of the TSW1400EVM and AFE5803EVM is working properly. If a different message or an error message appears, contact TI FAE.

Select **AFE5803, 14 bits, MSB first** from the GUI.

**ADC Sampling Rate** is fixed at 40 MHz; this is the onboard CMOS clock frequency.

**ADC Input Frequency** – enter 2M, and the GUI calculates the real coherent frequency to 2.00439453M.

Select AFE5803\_14X



ADC Input Frequency  
=> Enter 2 MHz

ADC Sampling Rate =>  
Enter 40 MHz

Select 65536

## 8 Test AFE5803

### 8.1 Step 1: Time Domain

- Select the Time Domain page from the TSW1400 GUI.

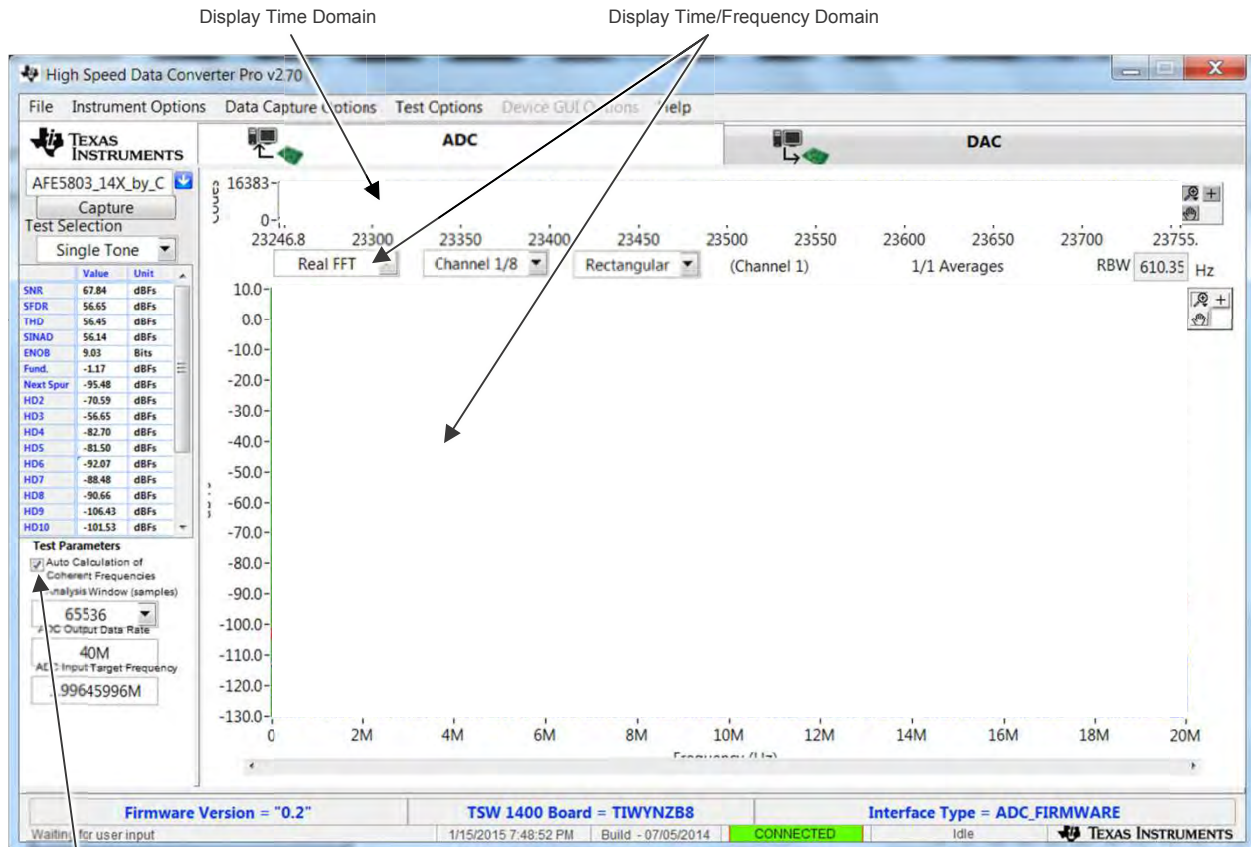

Make sure to check

- From the AFE5803 GUI, go to the **ADC** page, and then select **Ramp**.

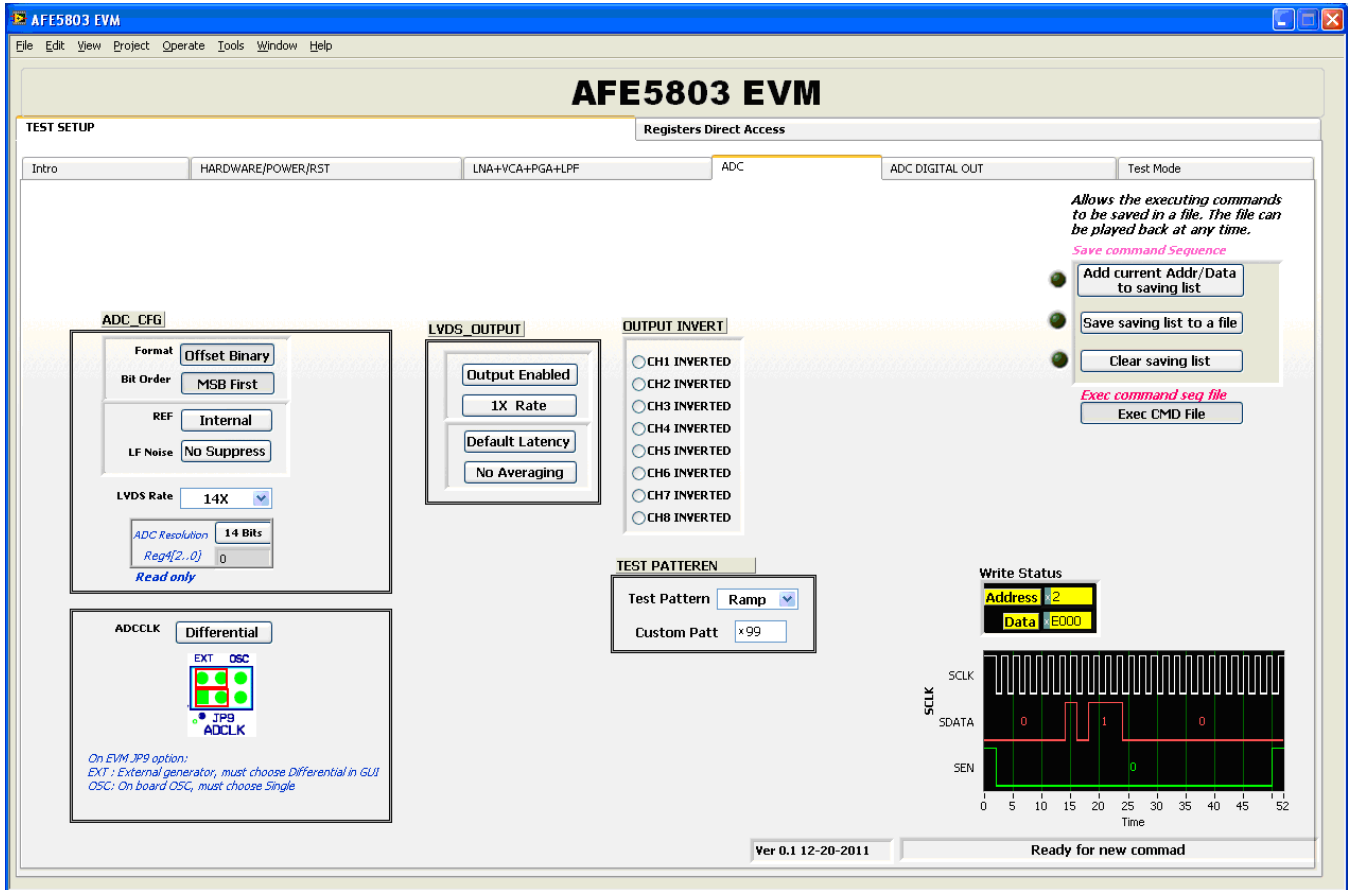

- Press the Capture button on the TSW1400 GUI. This displays a ramping waveform on the TSW1400 GUI display area as shown in the following illustration.



- Repeat for Channel 2 and Channel 8.
- **If each channel has the output as shown in the following illustration, proceed with the next step; otherwise, contact the TI FAE to troubleshoot the problem.**
- On the AFE5803 GUI, change Test Pattern from **Ramp** to **None** for the next step.

### 8.2 Step 2: Single Tone FFT

- Select the **Single Tone FFT** page at the TSW1400 GUI.
- Connect Channel 1 of the AFE5803EVM to a signal generator through an **LP filter**. If an LP filter is not present, the result will not be good.
- Set the amplitude of the signal generator to **-25dBm**.
- Set the frequency of the signal generator to **2.00439453M** to match the GUI.
- Change the window option to **Hanning**. This is because the input signal and the onboard CMOS clock are noncoherent.
- Press the Capture button to get the test result.
- Repeat for Channel 2 through Channel 8.

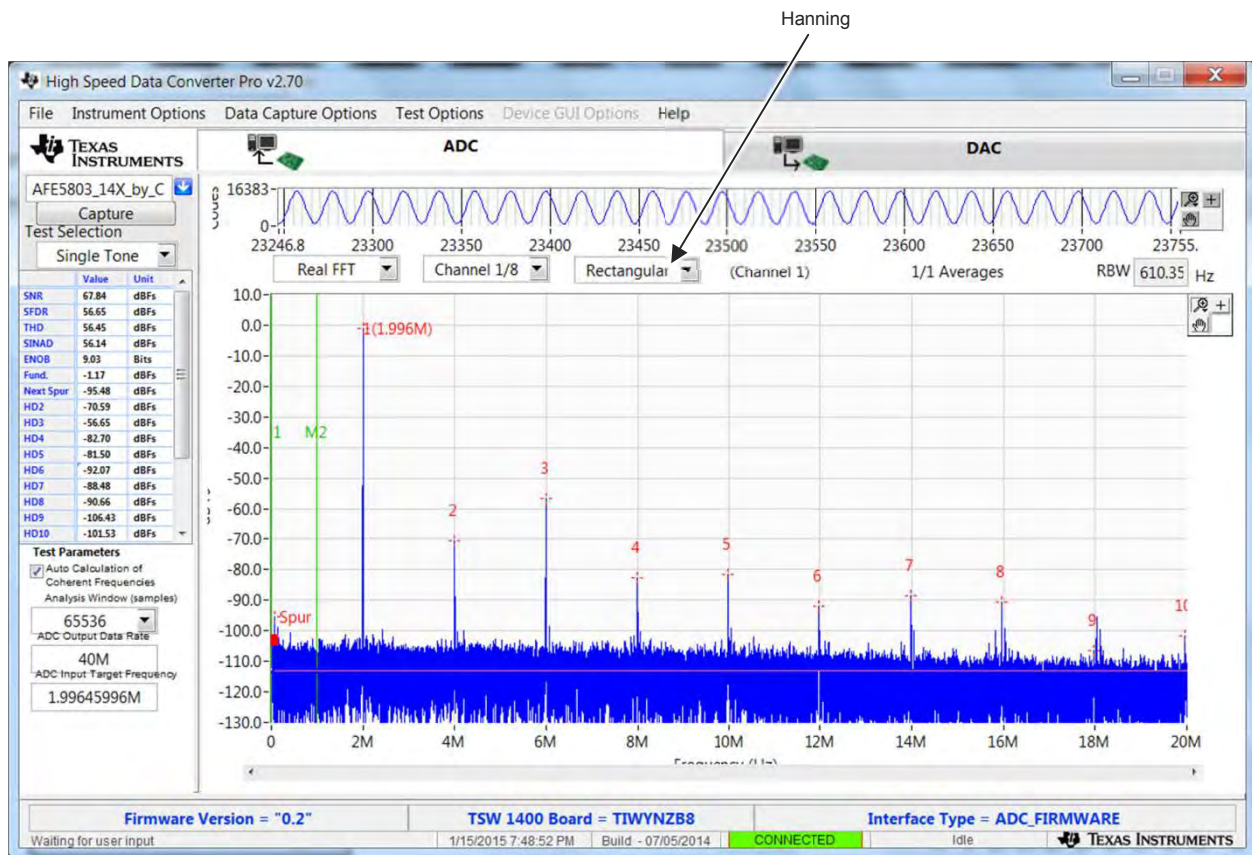

Figure 4. User Interface: Single FFT Format

## 9 External ADC Sampling Clock

To use the external clock generator to test the AFE5803, perform the following steps.

1. Reconfigure JP9 as shown in the following illustration. The rest of the jumpers remain the same.
2. Connect the external generator as shown in Figure 5.
3. Set the generator output to 40 MHz, 13 dBm.

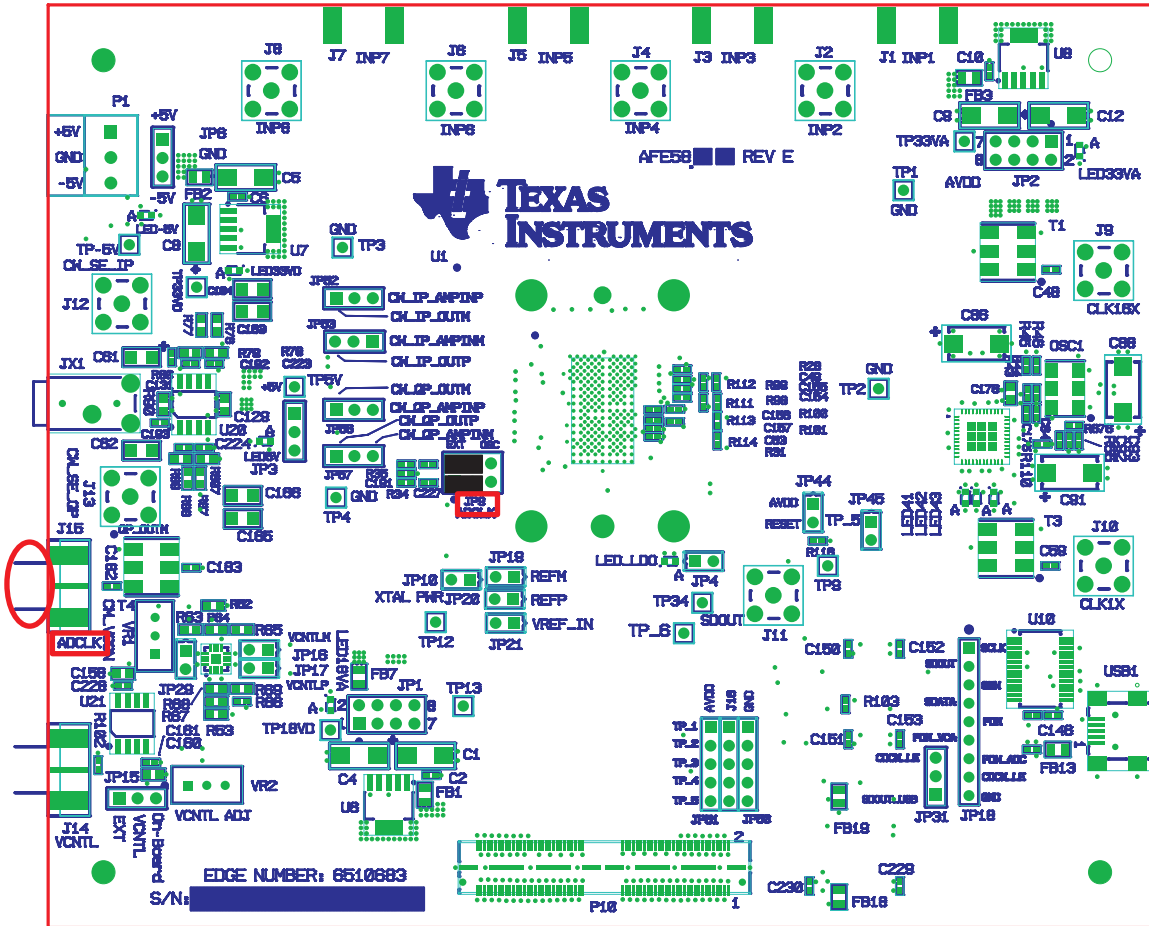
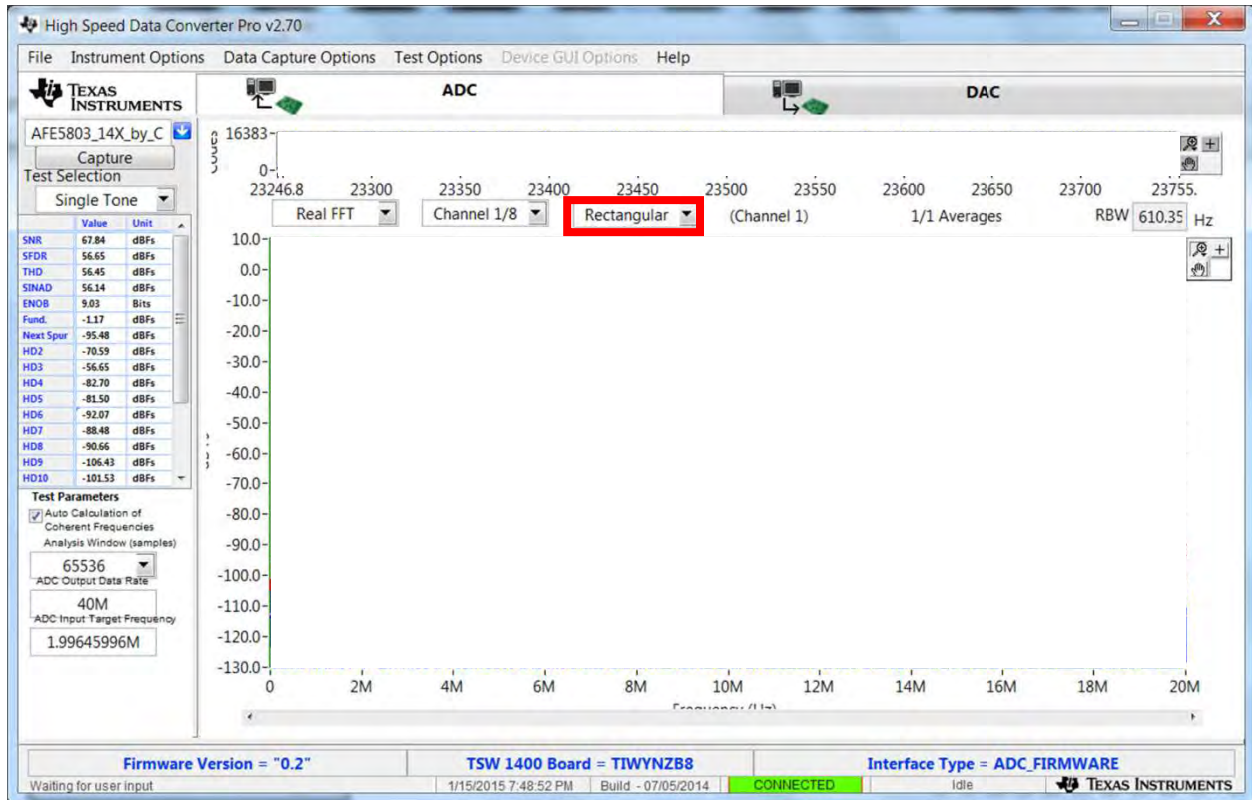

Figure 5. External ADC Sampling Clock Configuration

4. If the generators for the ADC clock and input signal are synchronous, then choose *Rectangular* as the Windowing option; otherwise, use *Hanning* or *Hamming*.



5. The test procedure is the same for the CMOS ADC clock.

## 10 External Vcntl

- JP15 needs to be reconfigured to short the leftmost two pins.
- A power supply is required to be connected as shown in Figure 6.

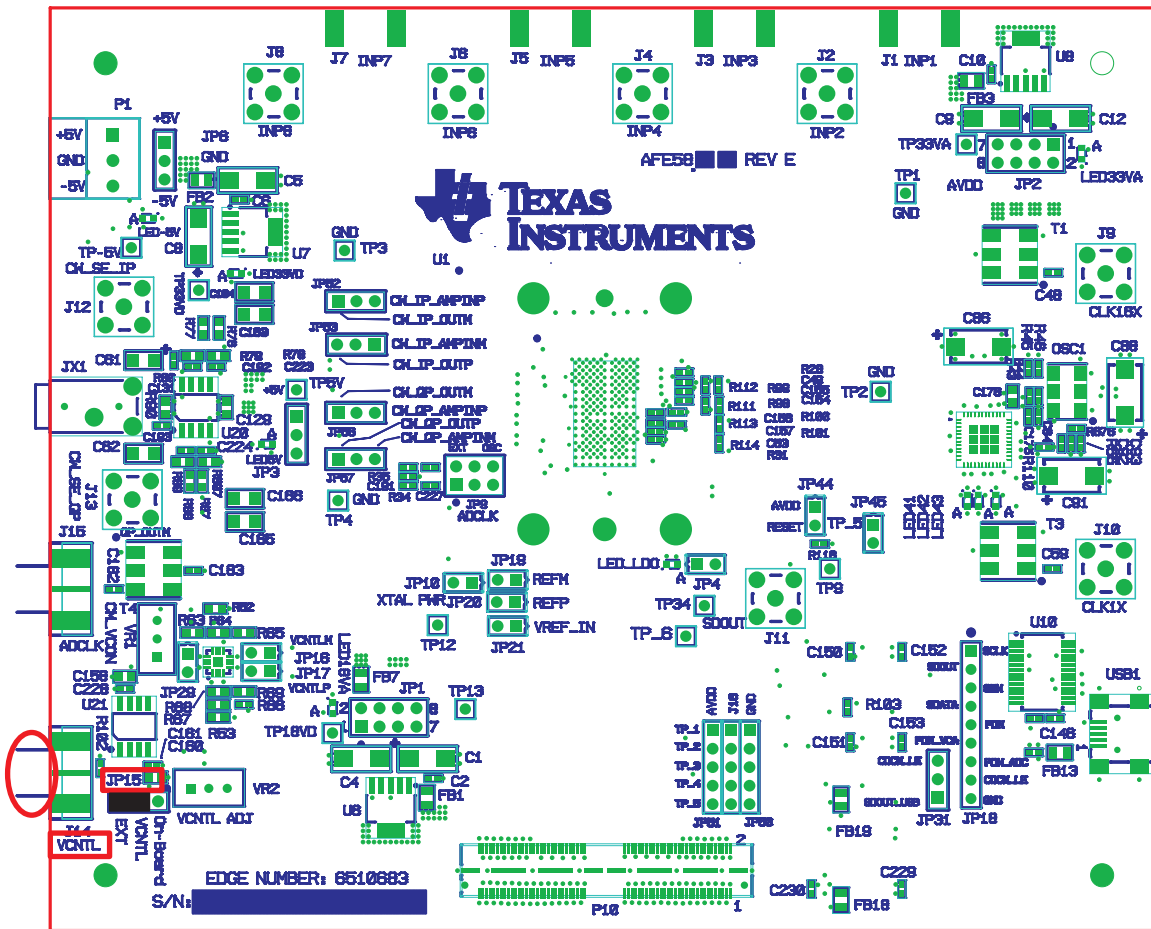

Figure 6. External Vcntl Configuration

## 11 Board Configuration

### 11.1 Input/Output, Power Supply, and USB

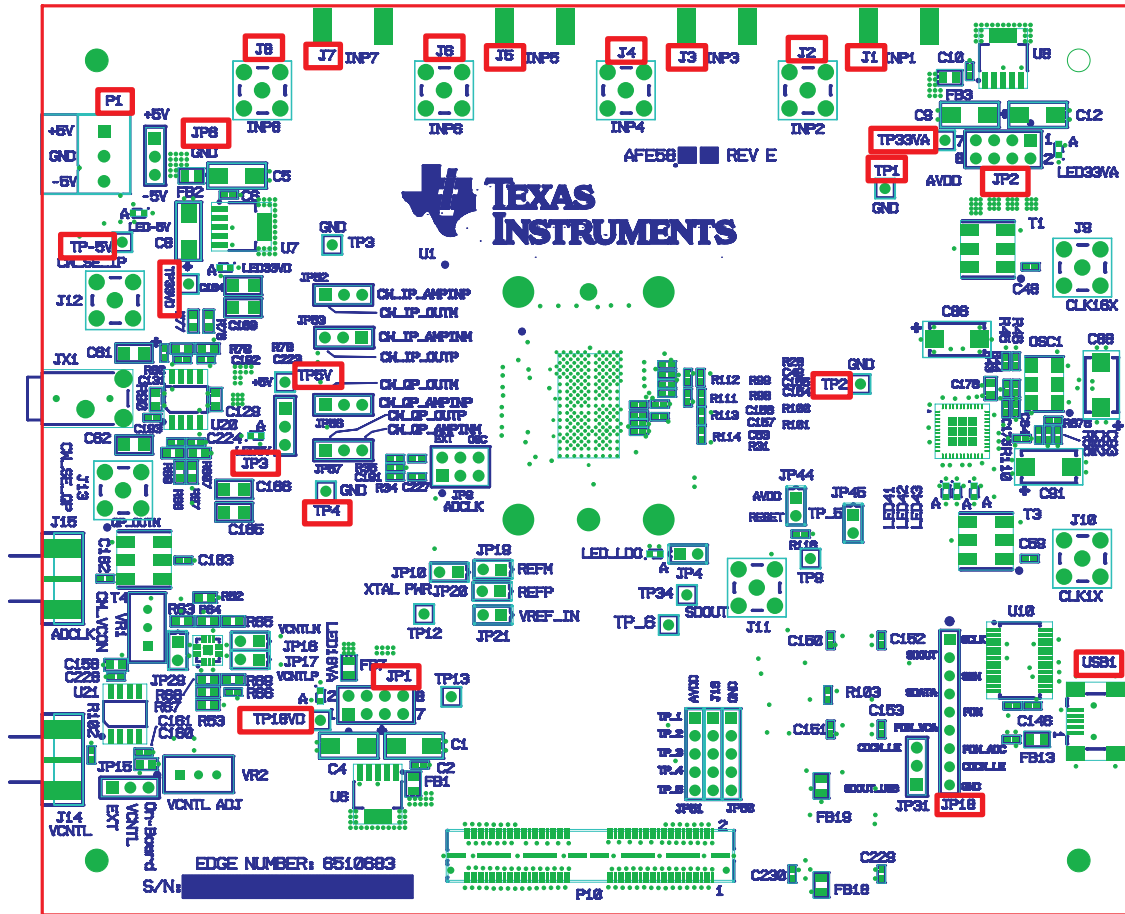

Figure 7. I/O, PWR, and USB Connector

Table 1. Input/Output, Power, and USB

| Connector       | Description   |
|-----------------|---|
| J1 through J8   | Analog Input signals for Ch1 through Ch8. Connect to a signal generator. A bandpass filter must be applied between the generator and the SMA to get a better result. (See <a href="#">Figure 1</a> .) |
| P1/JP6          | P1 is the +5-V and -5-V power supply connector. JP6 is the test point for +5-V/-5-V power supply.   |
| JP3             | Onboard 5-V enable. Set up as <a href="#">Figure 2</a> is a must to use onboard 5-V supply.   |
| XP-5V           | -5-V supply test point.   |
| TP5V            | +5-V supply test point.   |
| JP1             | Onboard +1.8-V enable. Set up as shown in <a href="#">Figure 2</a> ; required to use the onboard +1.8 V.  |
| JP2             | Onboard 3.3-VA enable. Set up as shown in <a href="#">Figure 2</a> ; required to use the onboard 3.3 V.   |
| TP18VD          | +1.8-VD supply test point.  |
| TP33VD          | +3.3-VD supply test point.  |
| TP33VA          | +3.3-VA supply test point.  |
| TP1 through TP4 | Ground test points.   |
| USB1            | USB interface connector   |
| JP18            | Test points for USB data bus: From pin 1 to pin 9 the signals are: D0, D4, D2, D1, D7, D5, D6, and D3   |

## 11.2 ADC Clock

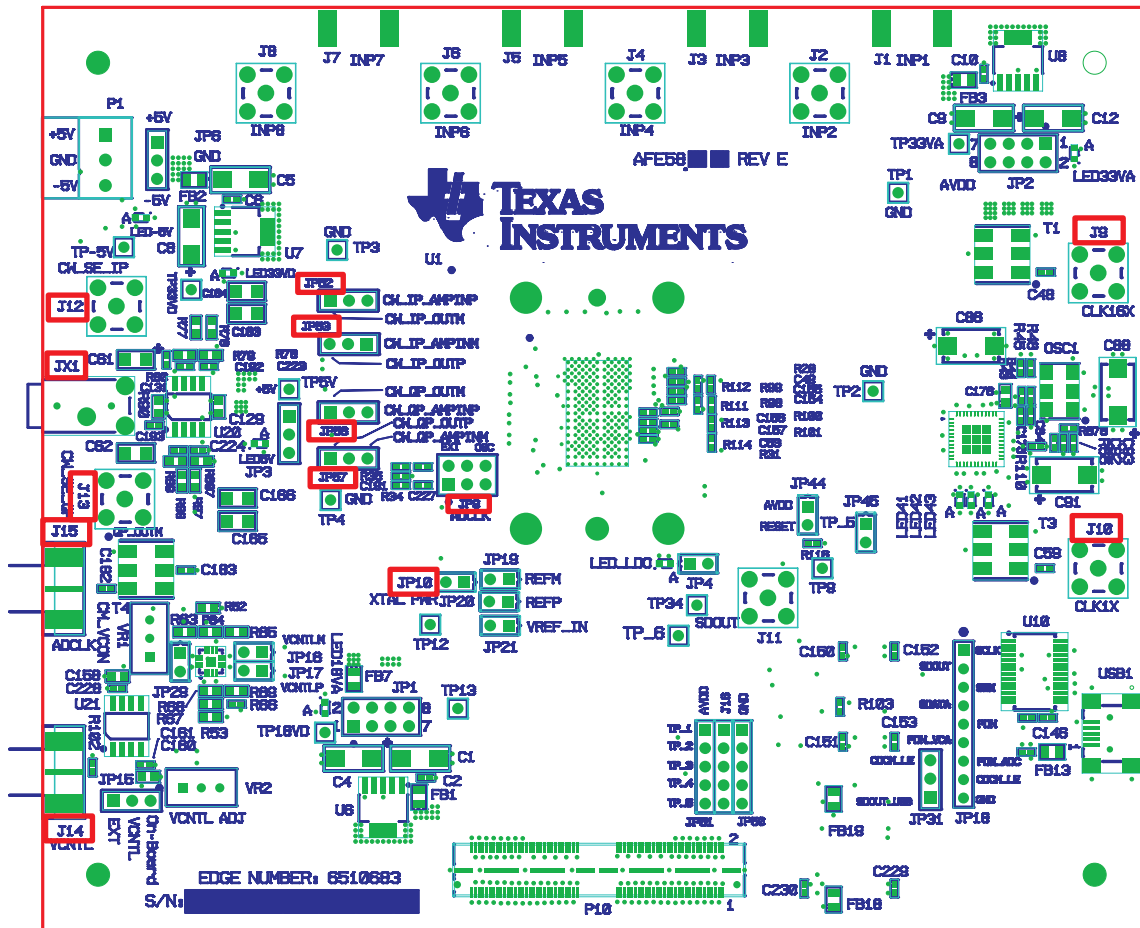

Figure 8. AFE5803EVM Jumper Locations

Table 2. PGATestMode, ADC Clock

| Clock Type | Reference Designator | Description   |
|------------|----------------------|---|
| PGA Test   | J9/J10/J12/J13       | N/A   |
|            | JP52/JP53/JP56/JP57  | Test points for PGA test mode.  |
| ADC        | JP9/JP10             | JP9 selects on_board_ADC CMOS clock or external clock from J14. Default setup uses onboard CMOS clock. Set it to the other side to use the external clock source. |
|            | J14                  | External ADC clock Input.   |



### 11.4 LEDs

The AFE5803EVM has seven LEDs. Their locations are shown in Figure 10. Their ON/OFF states demonstrate the normal operation of the power supplies and the PLL status of the clock buffer.

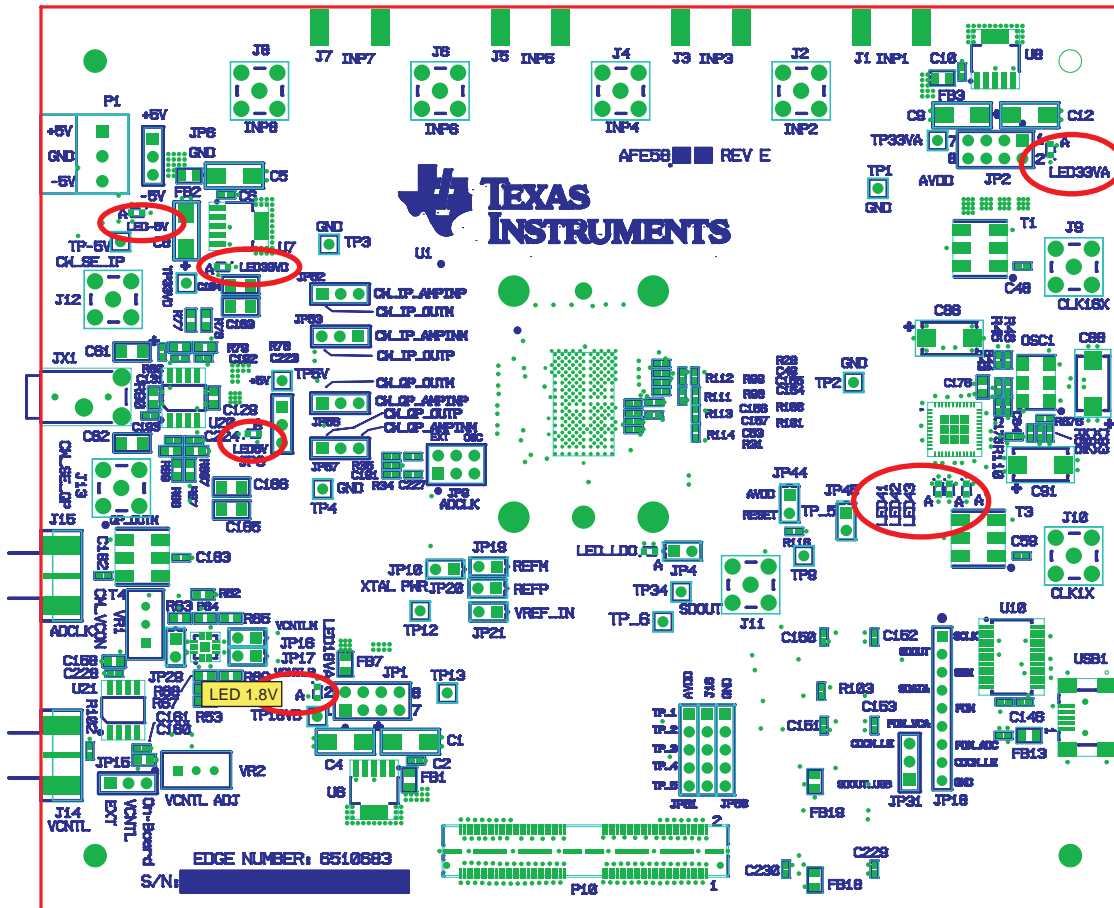

Figure 10. AFE5803EVM LED Location

Table 4. LED Indicators

| Reference Designator | Power Supply                  | Color  |
|----------------------|-------------------------------|--------|
| LED-5V               | -5 V                          | Green  |
| LED5V                | +5 V                          | Green  |
| LED3.3VD             | +3.3 VD                       | Orange |
| LED3.3VA             | +3.3 VA                       | Green  |
| LED1.8V              | +1.8 VV                       | Green  |
| LED41                | Clock Buffer Status Indicator | Red    |
| LED42                |                               | Red    |

### 11.5 Miscellaneous Test Points

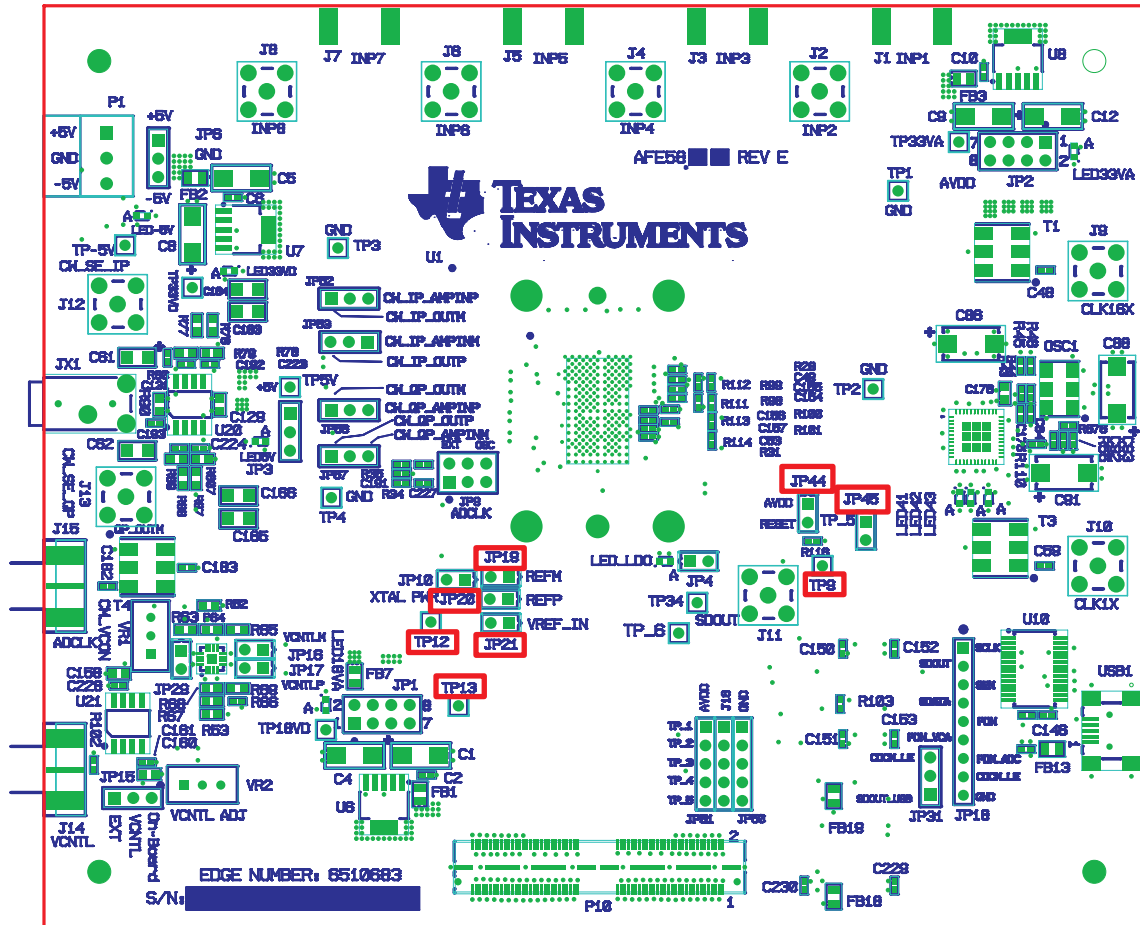

Figure 11. AFE5803EVM Test Point Locations

Table 5. Test Points

| Reference Designator  | Description                                |
|-----------------------|--|
| TP9, TP12, TP13, TP34 | AFE5803 device test pin M8, L5, M5, and M9 |
| JP19                  | REFM voltage input                         |
| JP31                  | SDOUT read enable                          |
| JP44                  | RESET input. Short to reset AFE5803.       |
| JP45                  | TP_5 control enable                        |
| JP20                  | REFP voltage input                         |
| JP21                  | REF_IN voltage input                       |

## 12 EVM Printed-Circuit Board Layouts and Schematics

The following illustrations show the six layers of the AFE5803EVM board.

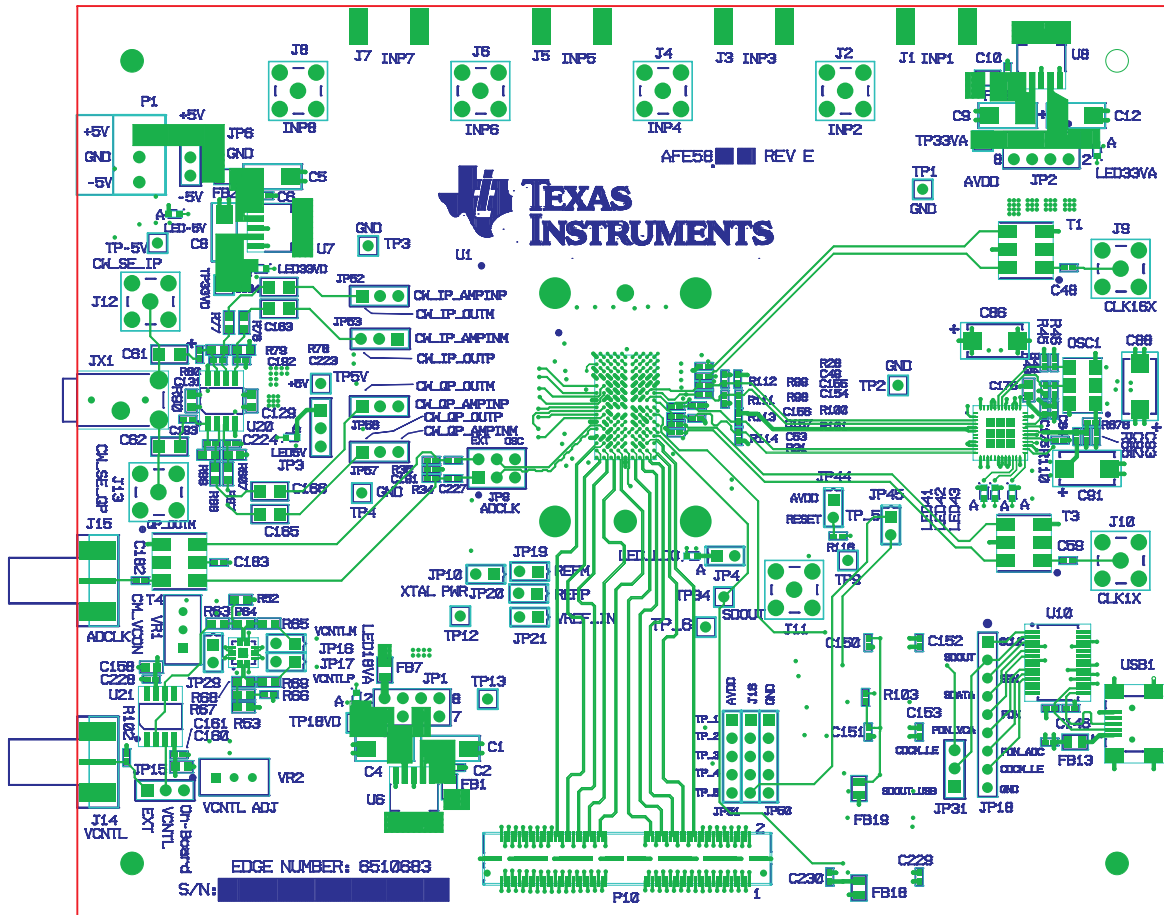
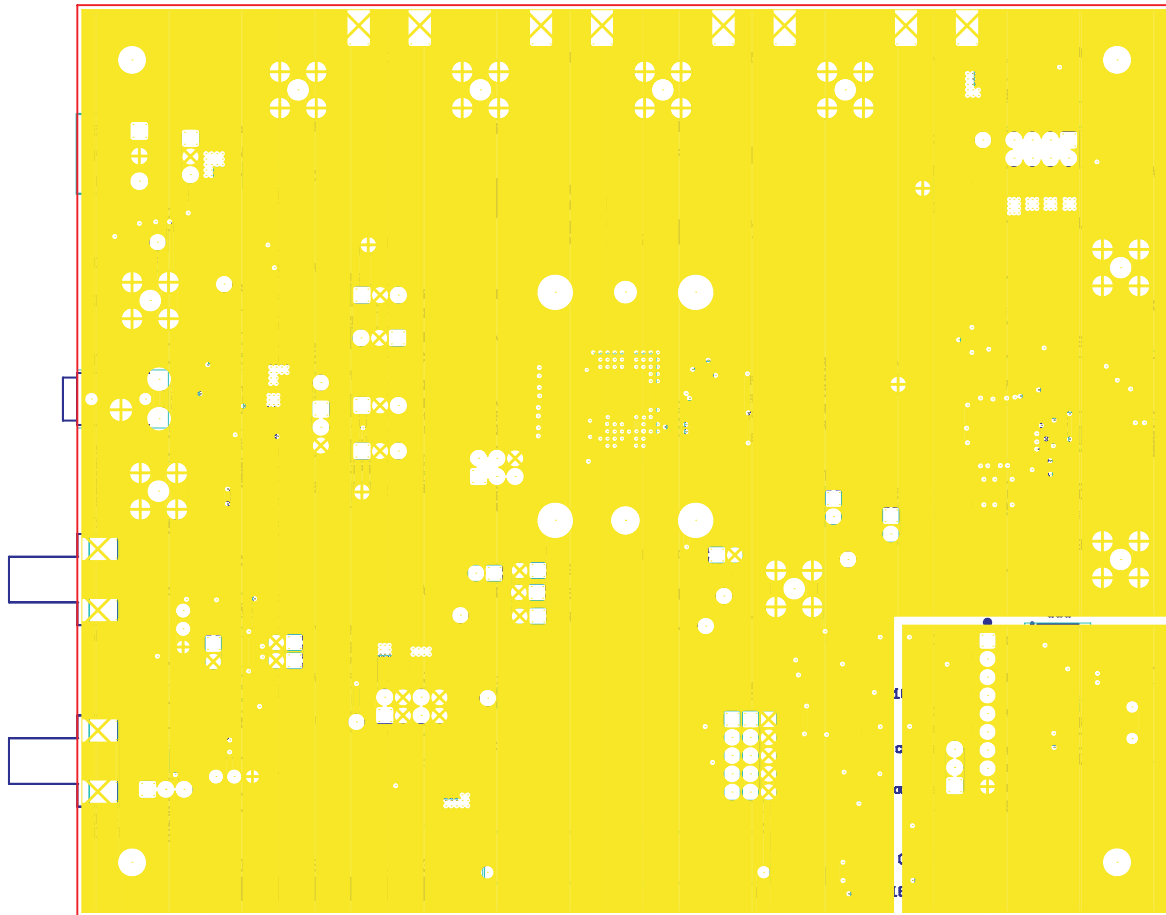
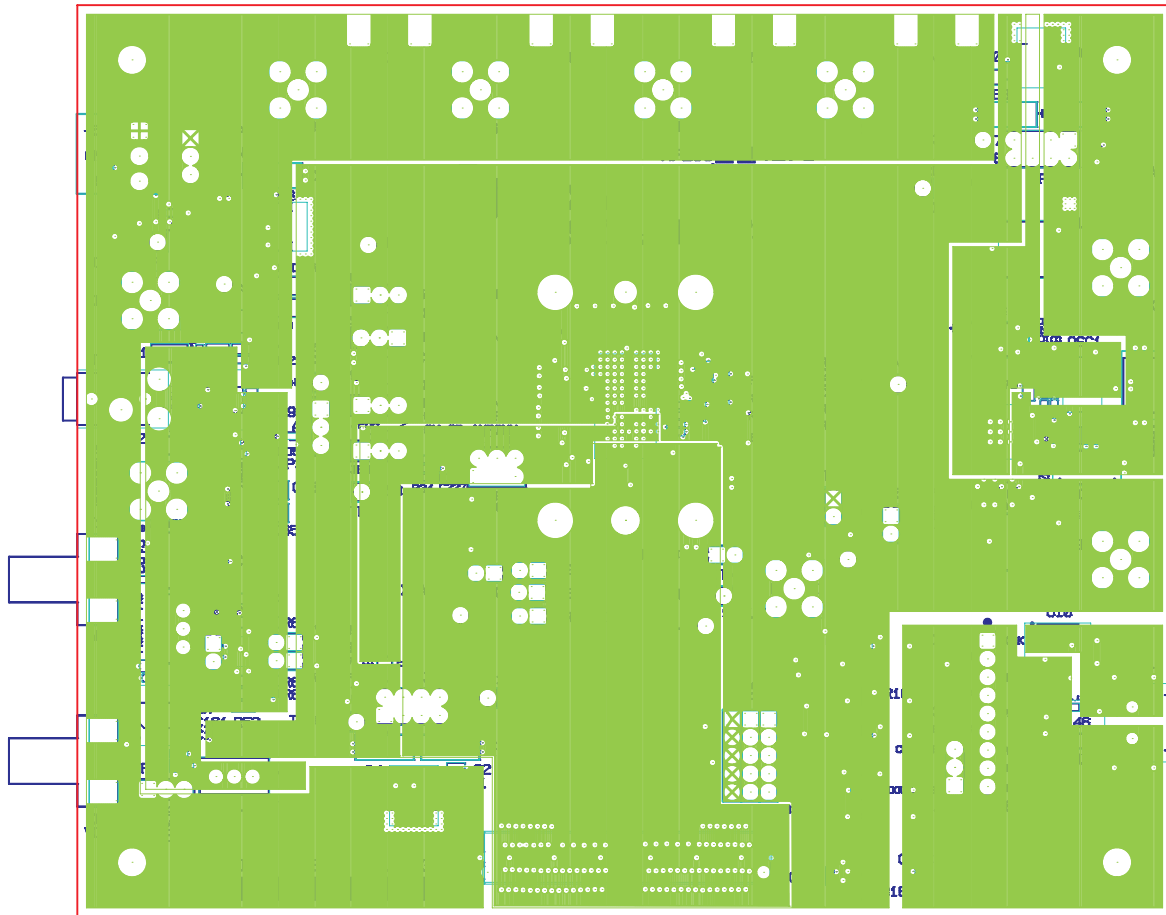

Figure 12. Top Layer - Signal



**Figure 13. Second Layer - Ground**



**Figure 14. Third Layer - Power**

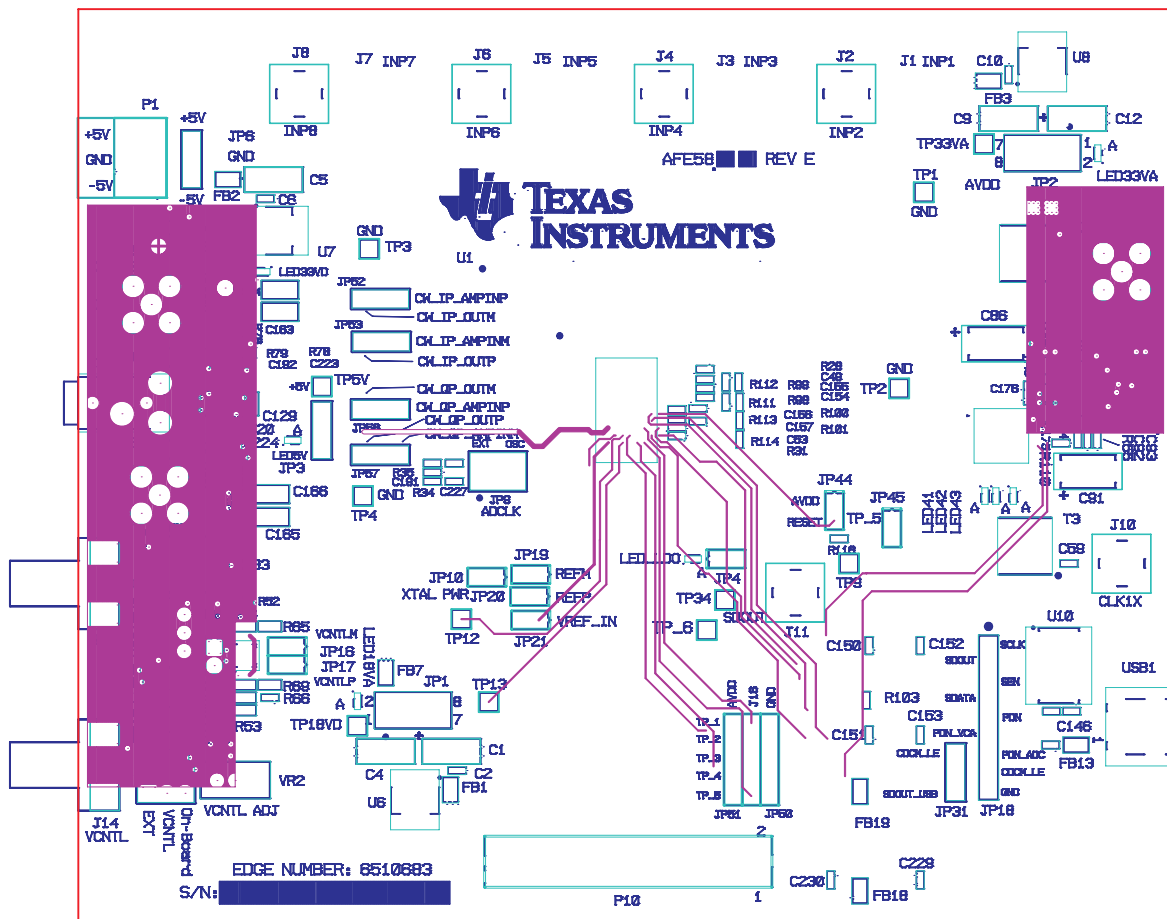
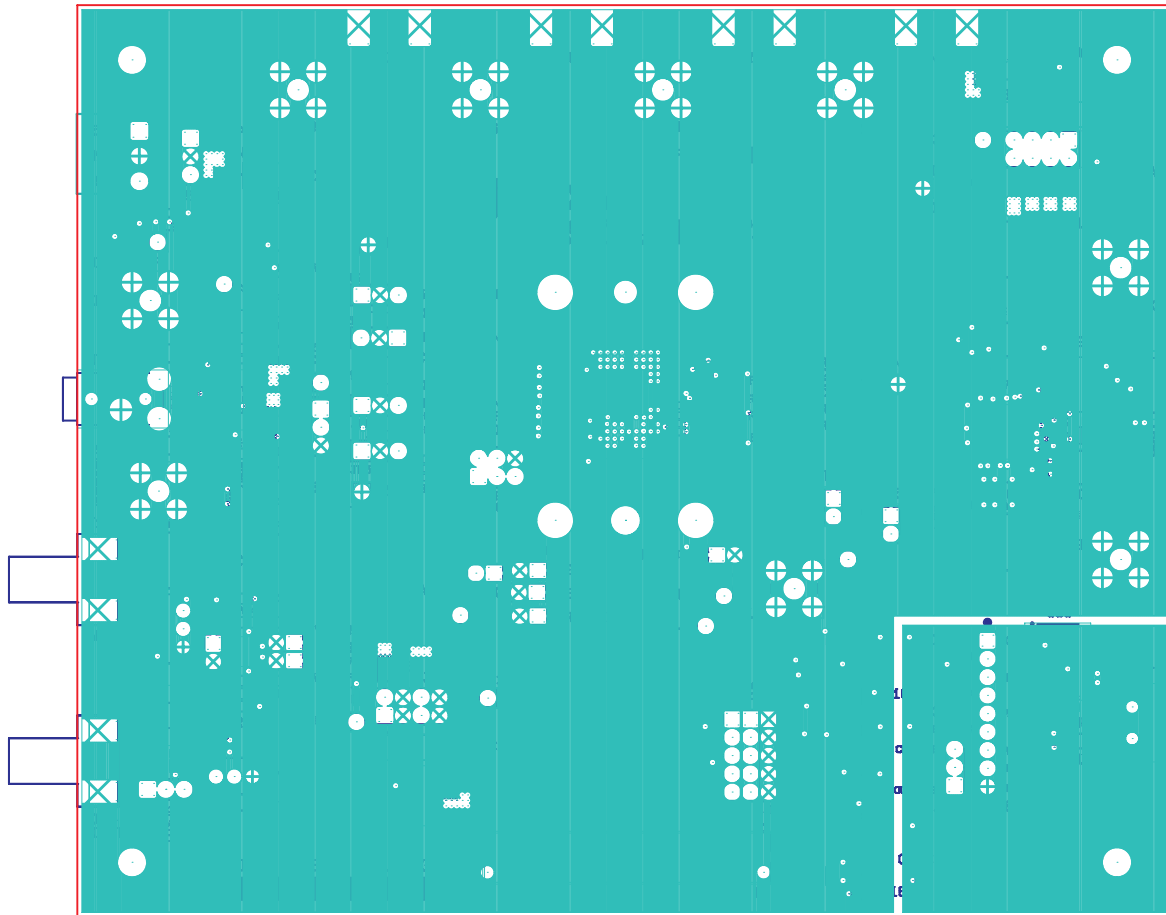

Figure 15. Fourth Layer - Signal



**Figure 16. Fifth Layer - Ground**







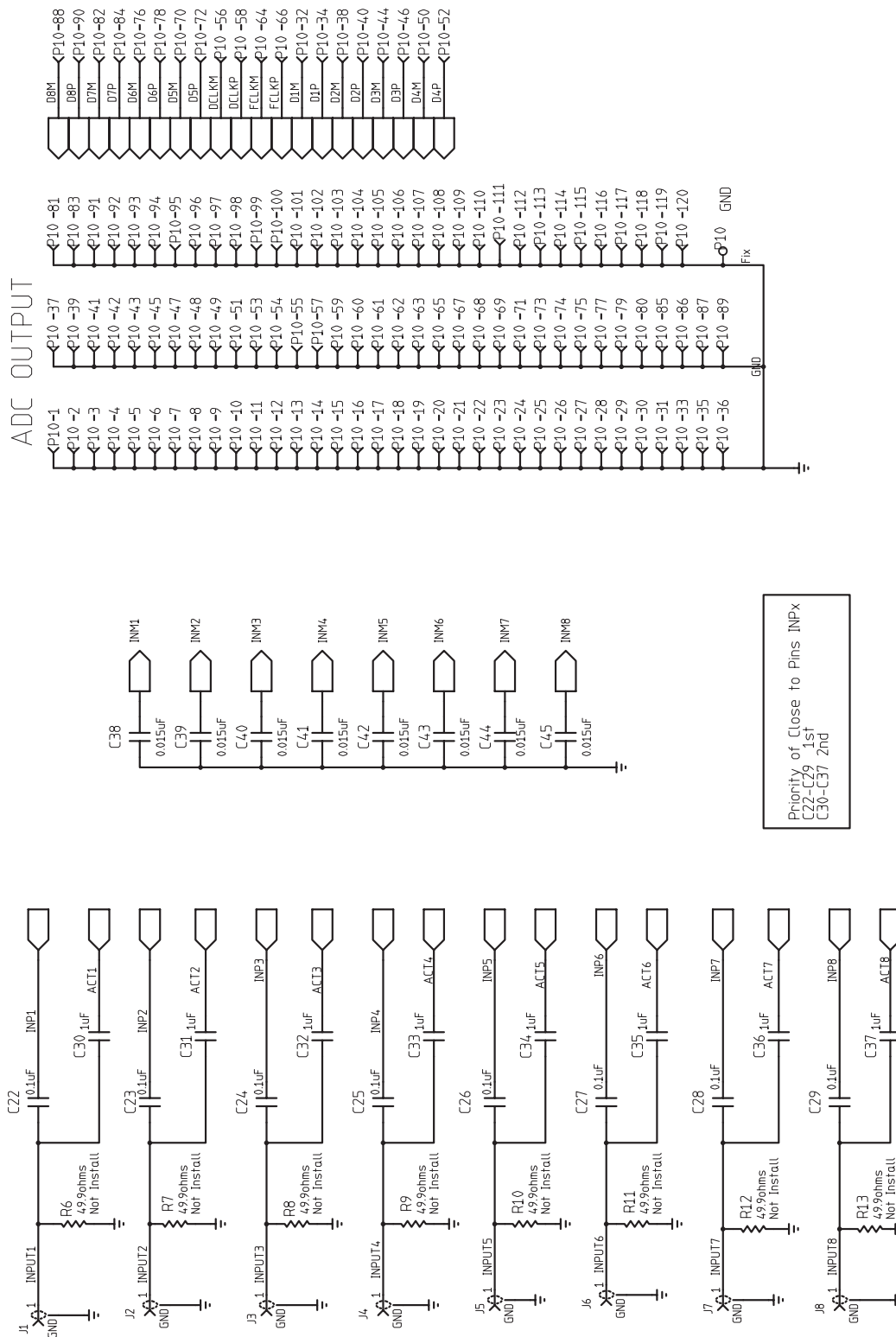

Figure 20. Schematic 3 of 9

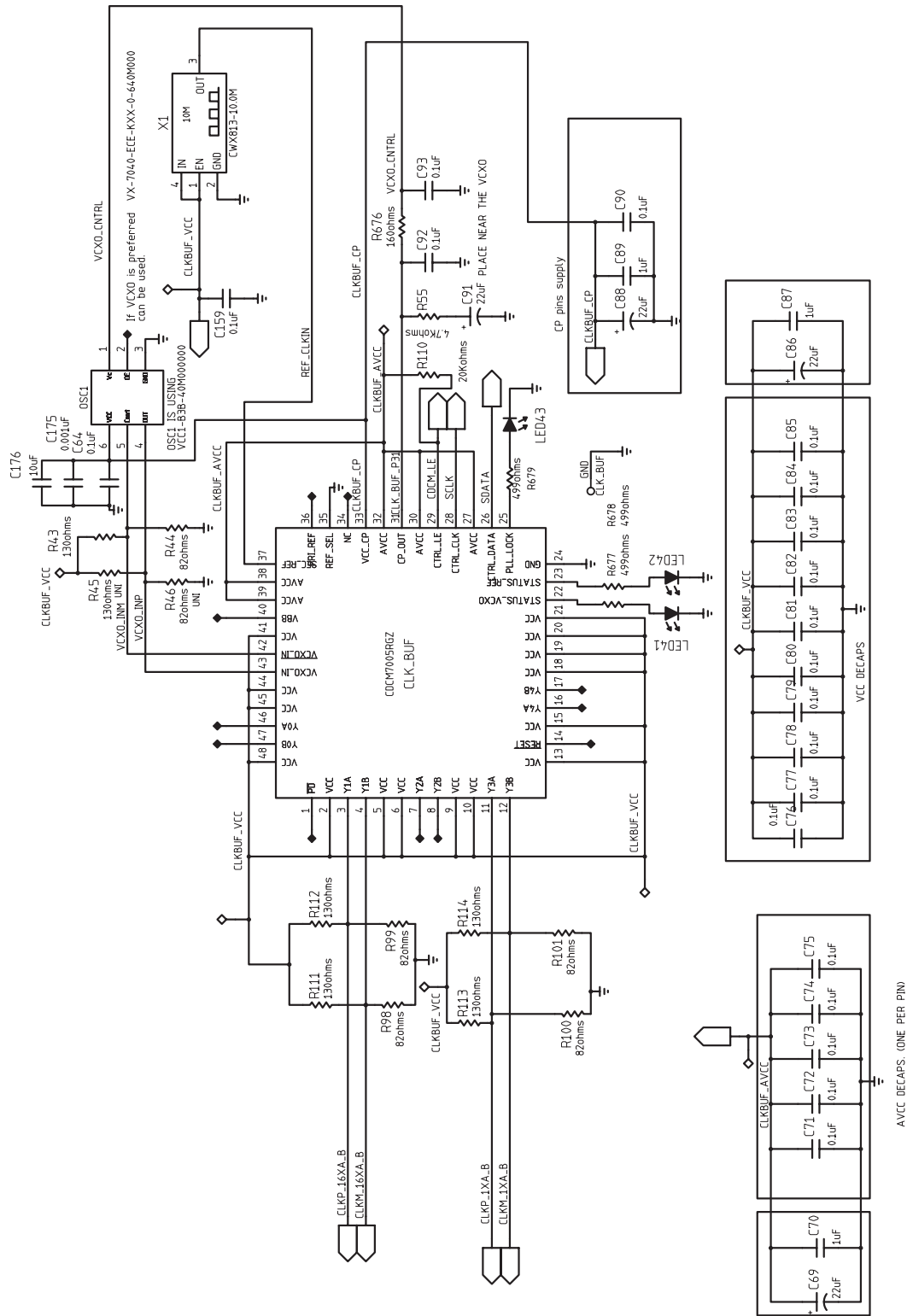

Figure 21. Schematic 4 of 9 (Not applicable to AFE5803)

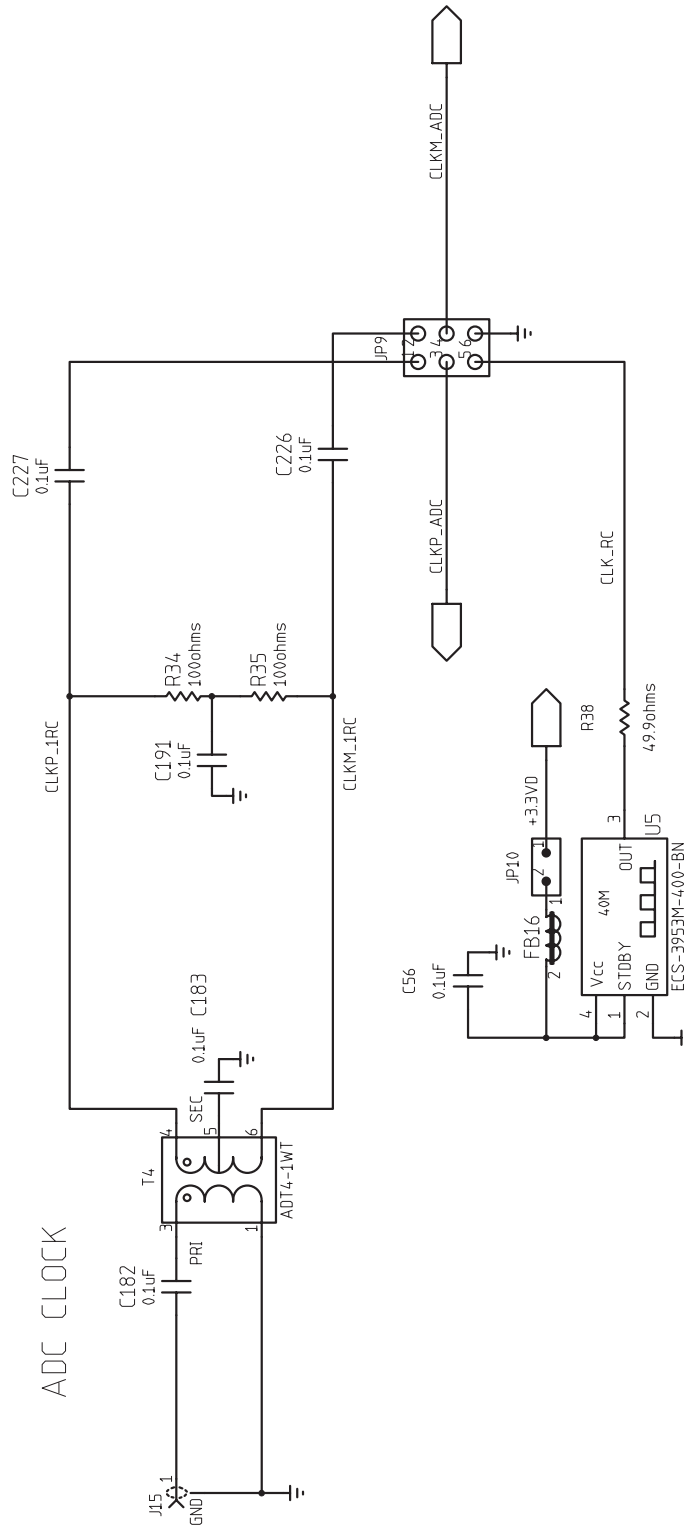

Figure 22. Schematic 5 of 9

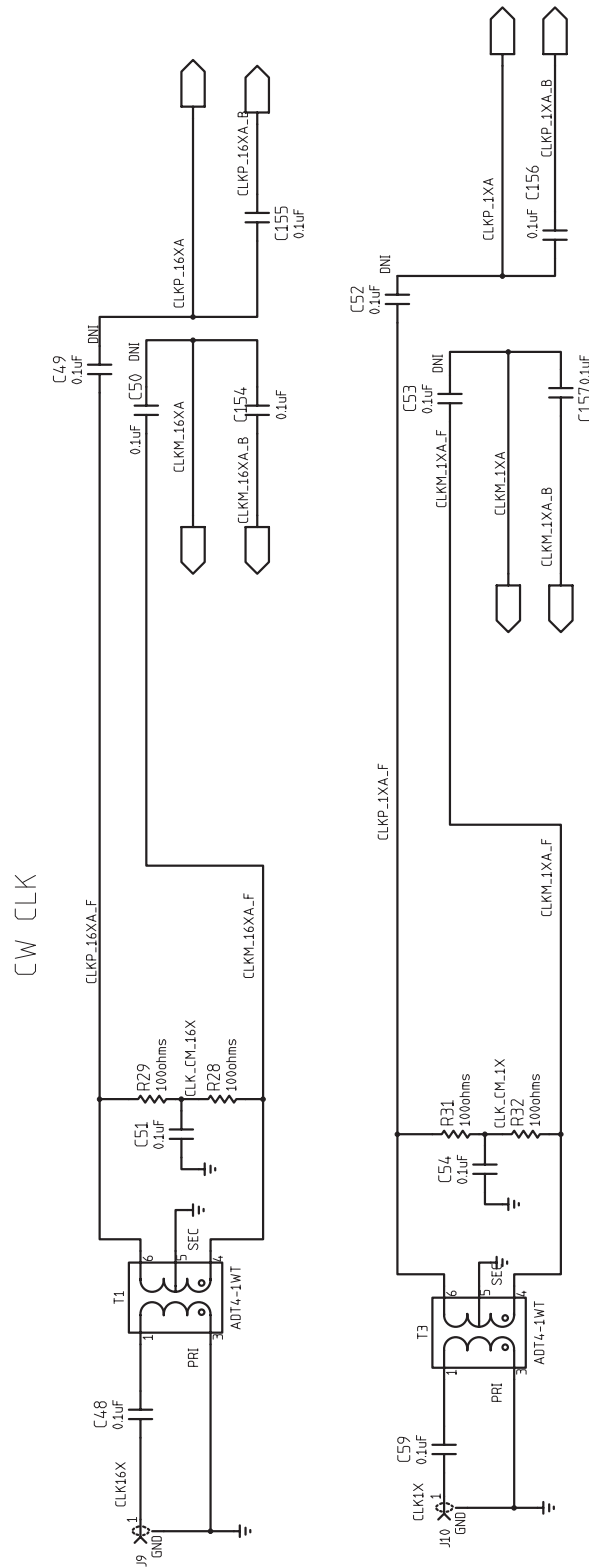

Figure 23. Schematic 6 of 9(Not applicable to AFE5803)



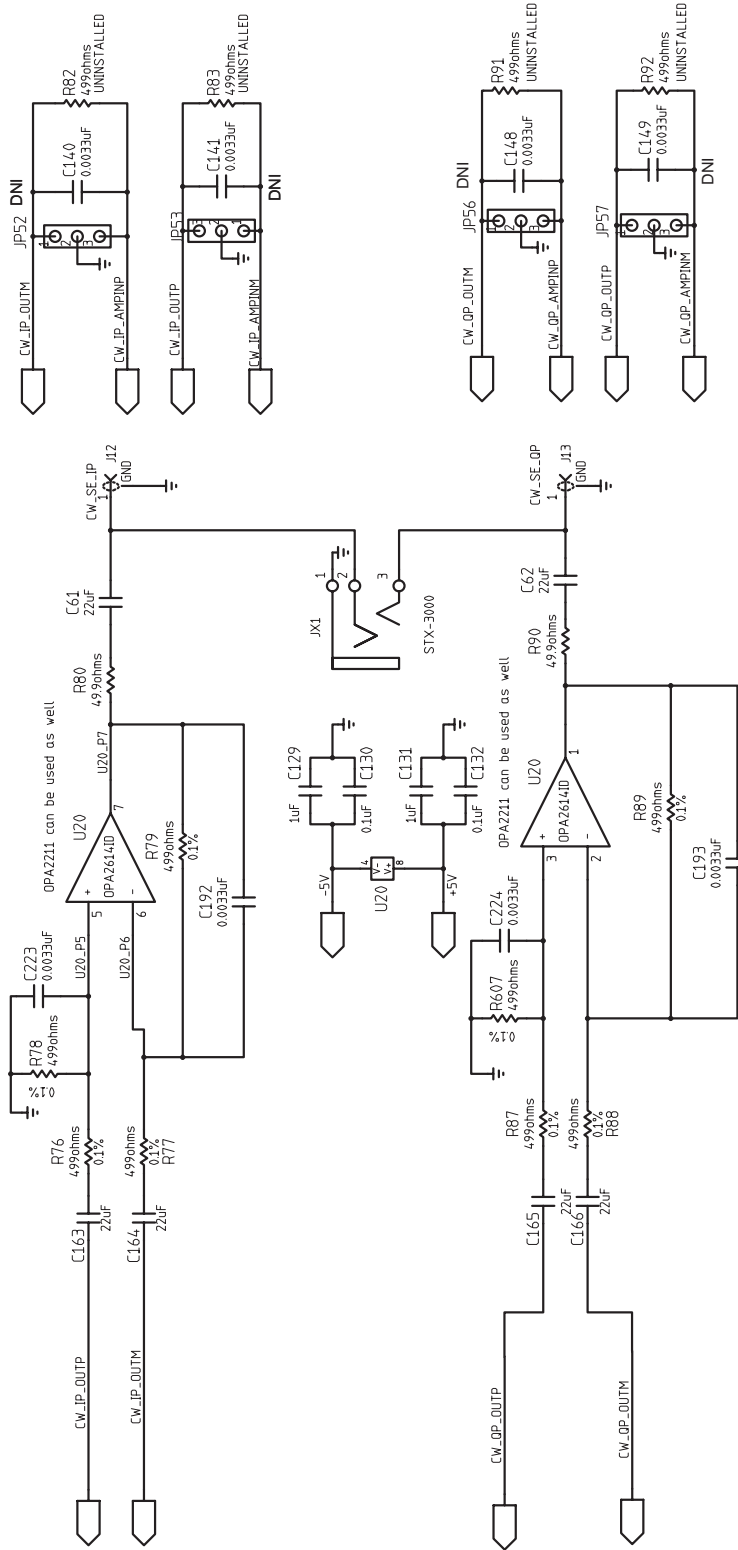

Figure 25. Schematic 8 of 9(Not applicable to AFE5803)

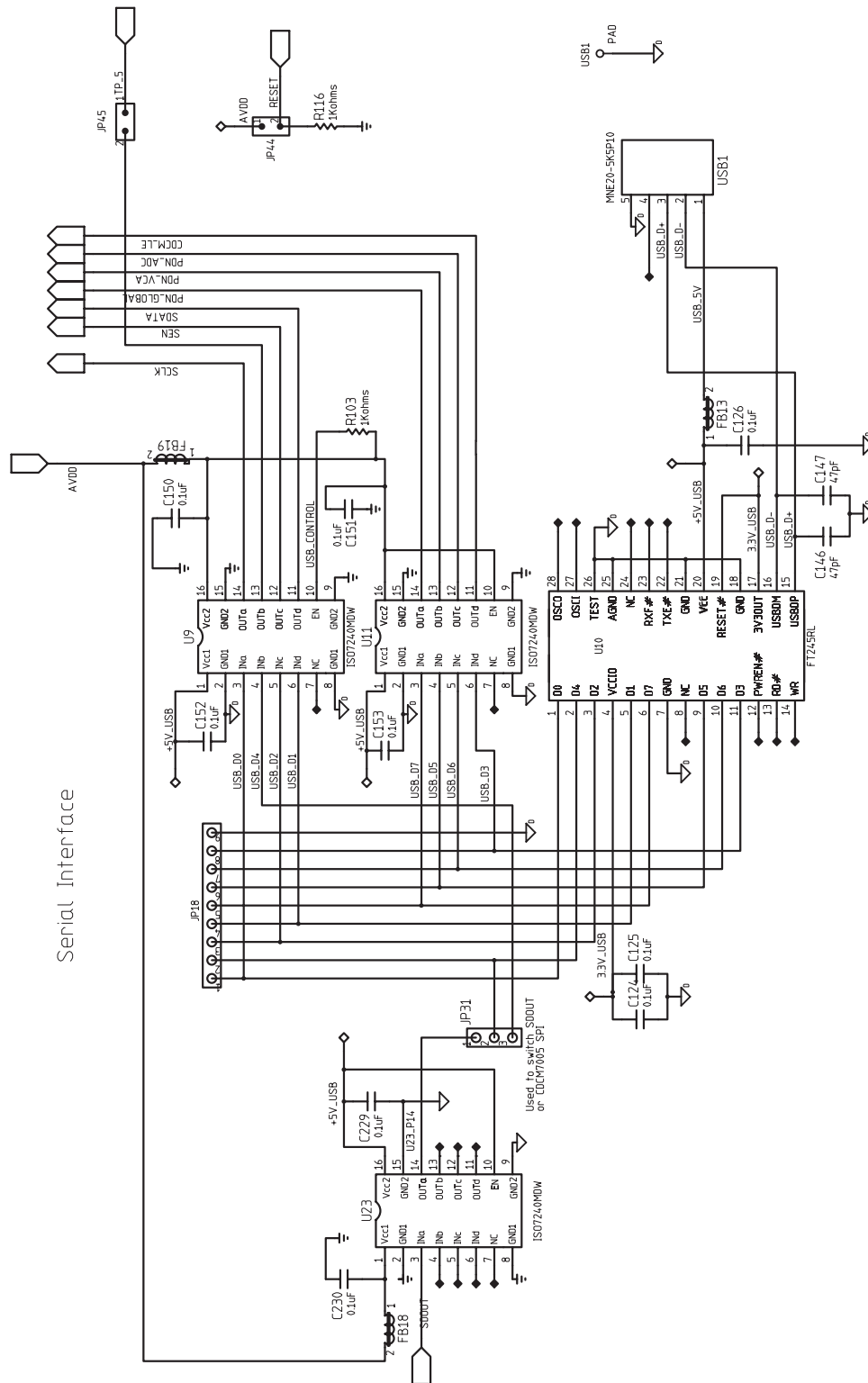

Figure 26. Schematic 9 of 9

### 13 Bill of Materials

**Table 6. Bill of Materials**

| QTY | MFG                | MFG Part#                  | REF DES   | Description        | Value or Function   | Distributor         | Distributor Part # |
|-----|--------------------|----------------------------|---|--------------------|---|---------------------|--------------------|
| 81  | AVX                | 0402YC104KAT2A             | C21, C22, C23, C24, C25, C26, C27, C28, C29, C48, C51, C54, C59, C64, C71, C72, C73, C74, C75, C76, C77, C78, C79, C80, C81, C82, C83, C84, C85, C90, C95, C96, C97, C98, C99, C100, C101, C102, C103, C104, C105, C106, C107, C108, C109, C112, C115, C118, C119, C120, C122, C123, C124, C125, C126, C130, C132, C150, C151, C152, C153, C154, C155, C156, C157, C159, C161, C182, C183, C191, C226, C227, C228, C229, C230 | CAP,SMT,0402       | CAPACITOR,SMT,0402,CER,16V,10%,0.1uF  | Digikey             | 445-4952-1-ND      |
| 4   | AVX                | 0402YC332KAT2A             | C192, C193, C223, C224  | CAP,SMT,0402       | CAPACITOR,SMT,0402,CER,16V,10%,3300pF   | Digikey             | 0402YC332KAT2A-ND  |
| 9   | KEMET              | C0402C104K8PAC             | C2, C3, C6, C7, C10, C11, C14, C18, C56   | CAP,SMT,0402       | CAPACITOR,SMT,0402,CER,0.1uF,10V,10%,X5R                                      | Digikey             | 445-4952-1-ND      |
| 4   | ANY                | C0402_PAD020X020_040LS(UN) | C113, C114, C231, C232  | CAP,SMT,0402       | <b>CAPACITOR,0402,ALTERNAT FOOTPRINT,PAD 020x020,040LS (Uninstalled Part)</b> |                     |                    |
| 8   | PANASONIC          | ECJ-0EB1C153K              | C38, C39, C40, C41, C42, C43, C44, C45  | CAP,SMT,0402       | CAPACITOR,SMT,0402,CERAMIC,0.015uF,16V,10%,X7R                                | Digi-Key            | PCC1701CT-ND       |
| 1   | PANASONIC          | ECJ-0EB1H102K              | C175  | CAP,SMT,0402       | CAPACITOR,SMT,0402,CER,1000pF,50V,10%,X7R                                     | Digi-Key            | 445-1256-2-ND      |
| 4   | PANASONIC          | ECJ-0EB1H332K              | C140, C141, C148, C149  | CAP,SMT,0402       | <b>CAPACITOR,SMT,0402,CER,3300pF,50V,10%,X7R DO NOT INSTALL</b>               | Digi-Key            | PCC1727CT-ND       |
| 2   | PANASONIC          | ECJ-0EC1H470J              | C146, C147  | CAP,SMT,0402       | CAPACITOR,SMT,0402,CER,47pF,50V,5%,NPO  | Digi-Key            | 490-1287-2-ND      |
| 2   | TAIYO YUDEN        | LMK105F104ZV               | C92, C93  | CAP,SMT,0402       | <b>CAPACITOR,SMT,0402,CERAMIC,10V,Y5V,0.1uF,20% DO NOT INSTALL</b>            |                     |                    |
| 2   | PANASONIC          | ECJ-0EB1A105M              | C110, C111  | CAP,SMT,0402       | CAPACITOR,SMT,0402,CERAMIC,1.0uF,10V,20%,X5R                                  | Digi-Key            | 587-1454-2-ND      |
| 5   | AVX                | 0603YD105KAT2A             | C121, C129, C131, C158, C160  | CAP,SMT,0603       | CAPACITOR,SMT,0603,CERAMIC,1.0uF,16V,10%,X5R                                  | Digi-Key            | 587-1241-2-ND      |
| 4   | PANASONIC          | ECJ-1VB1C105K              | C20, C70, C87, C89  | CAP,SMT,0603       | CAPACITOR,SMT,0603,CERAMIC,1.0uF,16V,10%,X5R                                  | Digi-Key            | 587-1241-2-ND      |
| 1   | TAIYO YUDEN        | JMK107BJ106MA-T            | C176  | CAP,SMT,0603       | CAPACITOR,SMT,0603,CERAMIC,10uF,6.3V,20%,X5R                                  | Digi-Key            | 445-4112-2-ND      |
| 6   | KEMET              | C1206C226K8PAC             | C61, C62, C163, C164, C165, C166  | CAP,SMT,1206       | CAPACITOR,SMT,1206,CERAMIC,22uF,10V,10%,X5R                                   | Digi-Key            | 399-4940-1-ND      |
| 5   | VISHAY SPRAGE      | 293D226X9016D2T            | C19, C69, C86, C88, C91   | CAP,SMT,7343       | <b>CAP,TAN,SMT, 22uF,16V,+/-10%,-55-85C DO NOT INSTALL C91</b>                | Digi-Key            | T495D226K035ATE300 |
| 8   | AVX                | TPSC226K016R0375           | C1, C4, C5, C8, C9, C12, C13, C17   | CAPACITOR,SMT,TANT | 10%, 16V, 22uF  | Digi-Key            | 718-1327-1-ND      |
| 1   | ADVANCED CONNECTEK | MNE20-5K5P10               | USB1  | CONN,SMT,5P        | MINI-AB USB OTG RECEPTACLE R/A SMT TYPE                                       | Samtec              | MUSB-05-S-AB-SM-A  |
| 6   | EFJOHNSON          | 142-0721-891               | J1, J3, J5, J7, J14, J15  | CONN,THU,SMA JACK  | SMA JACK END LAUNCH, 0.080 PCB THICK  | Heilind Electronics | 142-0701-801       |
| 9   | AMPHENOL           | 901-144-8                  | J2, J4, J6, J8, J9, J10, J11, J12, J13  | CONNECTOR,SMA      | SMA COAX STRAIGHT PCB CURRENT P/N IS 901-144-8RFX                             | Digi-key            | ARFX1231-ND        |
| 1   | TEXAS INSTRUMENTS  | AFE5803                    | U1  | CUSTOMER PROVIDE   | AFE5803   | Texas Instruments   | AFE5803            |

**Table 6. Bill of Materials (continued)**

| QTY | MFG                           | MFG Part#          | REF DES   | Description           | Value or Function  | Distributor | Distributor Part # |
|-----|-------------------------------|--------------------|---|-----------------------|--|-------------|--------------------|
| 1   | MURATA                        | BLM15BD102SN1D     | FB16  | FERRITE BEAD,SMT,0402 | FERRITE BEAD,SMT,0402,1K OHM,200mA                             | Digi-Key    | 490-1010-1-ND      |
| 16  | STEWART                       | HI0805R800R-00     | FB1, FB2, FB3, FB4, FB5, FB6, FB7, FB8, FB9, FB10, FB11, FB13, FB14, FB17, FB18, FB19 | FERRITE BEAD,SMT,2P   | FERRITE,SMT,0805,80 OHM@100MHz,5A                              | Digi-Key    | 240-2395-2-ND      |
| 1   | MOLEX                         | 39357-0003         | P1  | HEADER, THRU, 3P      | HEADER, THRU, POWER, 3P,3.5MM, EUROSTYLE                       | Digi-Key    | WM7878-ND          |
| 1   | SAMTEC                        | QTH-060-01-L-D-A   | P10   | HEADER,SMT,120P       | HEADER,SMT,120P,0.5mm,FEM,2BANK,RECEPTACLE,168/19 8H           | Digi-Key    | SAM8189-ND         |
| 1   | SAMTEC                        | TSW-103-07-G-D     | JP9   | HEADER,THU            | HEADER,THU,6P,2X3,MALE,DUAL ROW,100LS,100TL                    | Digi-Key    | HTSW-103-07-G-D-ND |
| 2   | SAMTEC                        | TSW-104-07-G-D     | JP1, JP2  | HEADER,THU            | HEADER,THU,8P,2X4,MALE,DUAL ROW,100LS,100TL                    | Digi-Key    | HTSW-104-07-G-D-ND |
| 3   | TYCO ELECTRONICS              | 4-103239-0X5       | J16, JP50, JP51   | HEADER,THU,5P         | HEADER, 1X5 .1CTRS   | Digi-Key    | A26512-05-ND       |
| 1   | SPC TECH                      | 8431-1x9           | JP18  | HEADER,THU,9P         | HEADER,THU,MALE,0.1LS,9P,1X9,335H,120TL                        | Samtec      | HTSW-150-07-G-S    |
| 10  | TYCO ELECTRONICS              | 4-103239-0x2       | JP4, JP10, JP16, JP17, JP19, JP20, JP21, JP29, JP44, JP45                             | HEADER,THU,JUMPER     | MALE,2PIN,,100CC MAKE FROM 4-103239-0x2                        | Digi-Key    | A26512-02-ND       |
| 8   | TYCO ELECTRONICS              | 4-103239-0x3       | JP3, JP6, JP15, JP31, JP52, JP53, JP56, JP57  | HEADER,THU,JUMPER     | MAKE FROM 4-103239-0   | Digi-Key    | A26512-03-ND       |
| 1   | TI                            | THS4520RGT         | VCON_OPAMP  | IC,SMT,QFN-16EP       | WIDEBAND,LOW NOISE/DISTORTION FULLY DIFFERENTIAL AMPLIFIER     | Digi-Key    | 296-20774-1-ND     |
| 1   | TEXAS INSTRUMENTS             | CDCM7005RGZ        | CLK_BUF   | IC,SMT,QFN-48         | 3.3-V HIGH PERFORMANCE CLOCK SYNTHESIZER AND JITTER CLEANER    | Digi-Key    | 296-18208-1-ND     |
| 3   | TI                            | ISO7240MDW         | U9, U11, U23  | IC,SMT,SOIC-16W       | QUAD DIGITAL ISOLATORS   | Digi-Key    | 296-22629-5-ND     |
| 1   | TI / BURR-BROWN               | OPA211AID          | U21   | IC,SMT,SOIC-8         | 1.1nV/Hz NOISE LOW POWER PRECISION OPERATIONAL AMPLIFIER       | Digi-Key    | 296-22634-1-ND     |
| 1   | TI                            | OPA2614ID          | U20   | IC,SMT,SOIC-8         | DUAL HI GAIN BWIDTH HI OUTPUT CURRENT OPAMP WITH CURRENT LIMIT | Digi-Key    | 296-17127-5-ND     |
| 1   | TI                            | TPS79618DCQR       | U6  | IC,SMT,SOT223-6       | ULTRALOW-NOISE HI PSRR FAST RF 1-A LDO LINEAR REGULATOR,1.8V   | Digi-Key    | 296-13762-1-ND     |
| 2   | TI                            | TPS79633DCQR       | U7, U8  | IC,SMT,SOT223-6       | ULTRALOW-NOISE HI PSRR FAST RF 1-A LDO LINEAR REGULATOR,3.3V   | Digikey     | 296-13766-1-ND     |
| 1   | FUTURE TECHNOLOGY DEVICE INT. | FT245RL            | U10   | IC,SMT,SSOP-28        | USB FIFO IC INCORPORATE FTDICHIP-ID SECURITY DONGLE            | Digikey     | 768-1011-1-ND      |
| 3   | PANASONIC                     | LNJ208R82RA        | LED41, LED42, LED43   | LED,SMT,0603          | LED,SMT,0603,ULTRA BRIGHT RED,1.92V                            | Digi-Key    | P11486CT-ND        |
| 5   | PANASONIC                     | LNJ308G8PRA        | LED-5V, LED33VA, LED33VD, LED5V, LED_LDO  | LED,SMT,0603          | LED,SMT,0603,PURE GREEN,2.03V                                  | Digi-Key    | 160-1443-2-ND      |
| 1   | PANASONIC                     | LNJ808R8ERA        | LED18VA   | LED,SMT,0603          | LED,SMT,0603,ORANGE,1.8V                                       | Digi-Key    | P523CT-ND          |
| 1   | CONNOR WINFIELD               | CWX813-10.0M       | X1  | OSC,SMT,4P            | OSCILLATOR,SMT,4P,3.3V,+/-25ppm,-20~70C,10.000 MHz             | Digi-Key    | CW516CT-ND         |
| 1   | OSC,SMT,4P                    | VCC1-B3B-40M000000 | OSC1  | OSC,SMT,4P            | OSCILLATOR,SMT,4P,7.5 X 5MM CRYSTAL TRISTATE                   |             |                    |
| 1   | ECS                           | ECS-3953M-400-BN   | U5  | OSCILLATOR,SMT,4P     | OSC,SMT,3.3V,50ppm,-40~85C,5nS,40.000 MHz                      | Digi-Key    | XC341CT-ND         |
| 1   | VENKEL                        | CR0402-16W-000T    | R70   | RES,SMT,0402          | RESISTOR,SMT,0402,0 OHM,1/16W,ZERO JUMPER                      | Digi-Key    | 311-0.0JRTR-ND     |
| 1   | VISHAY                        | CRCW0402000Z(UN)   | R115  | RES,SMT,0402          | ( UNINSTALLED PART )   |             |                    |
| 2   | VISHAY                        | CRCW04021001F100   | R103, R116  | RES,SMT,0402          | RESISTOR,SMT,0402,1K,1/16W,1%,100ppm                           | Digi-Key    | 541-1.00KLTR-ND    |
| 1   | VISHAY                        | CRCW04021002F100   | R62   | RES,SMT,0402          | RESISTOR,SMT,0402,10K,1/16W,1%,100ppm                          | Digi-Key    | RHM10.0KLTR-ND     |
| 2   | VISHAY                        | CRCW04022002F100   | R71, R110   | RES,SMT,0402          | RESISTOR,SMT,0402,20K,1/16W,1%,100ppm                          | Digi-Key    | ERJ-2RKF2002X      |

**Table 6. Bill of Materials (continued)**

| QTY | MFG                  | MFG Part#        | REF DES                                 | Description                      | Value or Function   | Distributor   | Distributor Part # |
|-----|----------------------|------------------|---|----------------------------------|---|---------------|--------------------|
| 1   | VISHAY               | CRCW04024701F100 | R55                                     | RES,SMT,0402                     | RESISTOR,SMT,0402,4.7K,1/16W,1%,100ppm DO NOT INSTALL         |               |                    |
| 3   | VISHAY               | CRCW04024990F100 | R677, R678, R679                        | RES,SMT,0402                     | RESISTOR,SMT,0402,499 OHM,1/16W,1%,100ppm                     | Digi-Key      | 541-499LTR-ND      |
| 1   | VISHAY               | CRCW04025110F100 | R5                                      | RES,SMT,0402                     | RESISTOR,SMT,0402,511 OHM,1/16W,1%,100ppm                     | Digi-Key      | P511LTR-ND         |
| 1   | PANASONIC            | ERJ-2GE0R00X     | R66                                     | RES,SMT,0402                     | RESISTOR/JUMPER,SMT,0402,0 OHM,5%,1/16W                       | Digi-Key      | 311-0.0JRTR-ND     |
| 1   | PANASONIC            | ERJ-2GEJ131      | R45                                     | RES,SMT,0402                     | RESISTOR,SMT,0402,THICK FILM,5%,1/16W,130 DO NOT INSTALL ,R45 |               |                    |
| 5   | PANASONIC            | ERJ-2GEJ131      | R43, R111, R112, R113, R114             | RES,SMT,0402                     | RESISTOR,SMT,0402,THICK FILM,5%,1/16W,130 ,R45                | Digi-Key      | 541-130LTR-ND      |
| 1   | PANASONIC            | ERJ-2GEJ161      | R676                                    | RES,SMT,0402                     | RESISTOR,SMT,0402,THICK FILM,5%,1/16W,160 DO NOT INSTALL      |               |                    |
| 4   | PANASONIC            | ERJ-2GEJ499      | R82, R83, R91, R92                      | RES,SMT,0402                     | RESISTOR,SMT,0402,THICK FILM,5%,1/16W,499 DO NOT INSTALL      |               |                    |
| 8   | PANASONIC            | ERJ-2GEJ49R9(U)  | R6, R7, R8, R9, R10, R11, R12, R13      | RES,SMT,0402                     | ( UNINSTALLED PART )  |               |                    |
| 1   | PANASONIC            | ERJ-2GEJ820      | R46                                     | RES,SMT,0402                     | RESISTOR,SMT,0402,THICK FILM,5%,1/16W,82 DO NOT INSTALL R46   |               |                    |
| 5   | PANASONIC            | ERJ-2GEJ820      | R44, R98, R99, R100, R101               | RES,SMT,0402                     | RESISTOR,SMT,0402,THICK FILM,5%,1/16W,82 R46                  | Digi-Key      | P82.0LTR-ND        |
| 8   | PANASONIC            | ERJ-2RKF1000X    | R4, R28, R29, R31, R32, R34, R35, R93   | RES,SMT,0402                     | RESISTOR,SMT,0402,100 OHM,1%,1/10W                            | Digi-Key      | 311-100LRTR-ND     |
| 3   | PANASONIC            | ERJ-2RKF3320X    | R1, R2, R3                              | RES,SMT,0402                     | RESISTOR,SMT,0402,332 OHM,1%,1/16W                            | Digi-Key      | 541-332LTR-ND      |
| 5   | PANASONIC            | ERJ-2RKF49R9X    | R38, R56, R80, R90, R102                | RES,SMT,0402                     | RESISTOR,SMT,0402,49.9 OHM,1%,1/16W                           | Digi-Key      | 311-49.9LRTR-ND    |
| 2   | VISHAY               | CRCW0603200F     | R65, R69                                | RES,SMT,0603                     | RESISTOR,SMT,0603,1%,1/10W,200 OHM                            | Digi-Key      | P200HTR-ND         |
| 2   | VISHAY               | CRCW0603487F     | R63, R67                                | RES,SMT,0603                     | RESISTOR,SMT,0603,1%,1/10W,487 OHM                            | Digi-Key      | P487HTR-ND         |
| 2   | VISHAY               | CRCW0603511F     | R52, R53                                | RES,SMT,0603                     | RESISTOR,SMT,0603,1%,1/10W,511 OHM                            | Digi-Key      | 311-511HRTR-ND     |
| 2   | PANASONIC            | ERJ-3GSYJ499     | R64, R68                                | RES,SMT,0603                     | RESISTOR,SMT,0603,1%,1/10W,499                                | Digi-Key      | P499HTR-ND         |
| 8   | VISHAY               | TNPW06034990BT9  | R76, R77, R78, R79, R87, R88, R89, R607 | RES,SMT,0603                     | RESISTOR,SMT,0603,THIN FILM,499 OHM 0.1%,1/10W,25ppm          | Digi-Key      | RG16P499BCT-ND     |
| 1   | KYCON                | STX-3000         | JX1                                     | STEREO PHONE JACK,THU,3 PIN      | STEREO PHONE JACK,THU,3 PIN,3.5mm                             | Mouser        | 806-STX-3000       |
| 5   | KEYSTONE ELECTRONICS | 5000             | TP_6, TP18VD, TP33VA, TP33VD, TP5V      | TESTPOINT,THU,1P                 | TESTPOINT,THU,MINIATURE,0.1LS,120TL, RED                      | Digi-Key      | 5000K-ND           |
| 4   | KEYSTONE ELECTRONICS | 5001             | TP1, TP2, TP3, TP4                      | TESTPOINT,THU,1P                 | TESTPOINT,THU,MINIATURE,0.1LS,120TL, BLACK                    | Digi-Key      | 5001K-ND           |
| 1   | KEYSTONE ELECTRONICS | 5002             | TP-5V                                   | TESTPOINT,THU,1P                 | TESTPOINT,THU,MINIATURE,0.1LS,120TL, WHITE                    | Digi-Key      | 5002K-ND           |
| 4   | KEYSTONE ELECTRONICS | 5004             | TP9, TP12, TP13, TP34                   | TESTPOINT,THU,1P                 | TESTPOINT,THU,MINIATURE,0.1LS,120TL, YELLOW                   | Digi-Key      | 5002K-ND           |
| 3   | MINI-CIRCUITS        | ADT4-1WT         | T1, T3, T4                              | TRANSF,SMT,6P                    | RF TRANSFORMER WIDEBAND, 2-775 MHz, 50 OHM                    | Mini Circuits | ADT4-1WT+          |
| 1   | BOURNS               | 3296W-1-103      | VR2                                     | TRIMPOT,THU,3P                   | TRIMPOT,THU,10K,10%,0.5W,100ppm,25T                           | Digi-Key      | 3296W-103LF-ND     |
| 1   | BOURNS               | 3296W-1-103      | VR1                                     | TRIMPOT,THU,3P                   | TRIMPOT,THU,10K,10%,0.5W,100ppm,25T                           | Digi-Key      | 3296W-103LF-ND     |
| 4   | KEYSTONE ELECTRONICS | 2029             |   | STANDOFF RND 4-40THR .750"L ALUM | "Round, Threaded, Female/Female                               | Digi-Key      | 2029K-ND           |
| 4   | KEYSTONE ELECTRONICS | H703-ND          |   | Machine Screw, 4-40              | SCREW MACHINE PHIL 4-40X1/4 SS                                | Digi-Key      | H703-ND            |

**Table 6. Bill of Materials (continued)**

| QTY | MFG             | MFG Part#      | REF DES                                   | Description  | Value or Function                              | Distributor | Distributor Part # |
|-----|-----------------|----------------|---|--------------|--|-------------|--------------------|
| 8   | TDK Corporation | C1005X5R0J105M | C30, C31, C32, C33,<br>C34, C35, C36, C37 | CAP,SMT,0402 | CAP CER 1.0UF 6.3V X5R 20% 0402                | Digi-Key    | 445-1415-1-ND      |
|     |                 |                | C49,C50,C116,C117,<br>C52,C53             |              | <b>DO NOT INSTALL C49,C50,C116,C117C52,C53</b> |             |                    |

**NOTE:** ASTERISK(\*) NEXT TO PART MANUFACTURER'S NAME DENOTES POSSIBLE LONG LEAD TIME ITEM.  
 RoHs note : all parts should comply with RoHs and Lead free, as well as the PCBs.

## High Speed Data Converter Pro (HSDCPro) Installation

Download the HSDCPro GUI Installer using this link: [HSDCPro GUI](#)

- Unzip the saved folder and run the installer executable to obtain the pop-up shown in [Figure 27](#).
- Click the *Install* button.

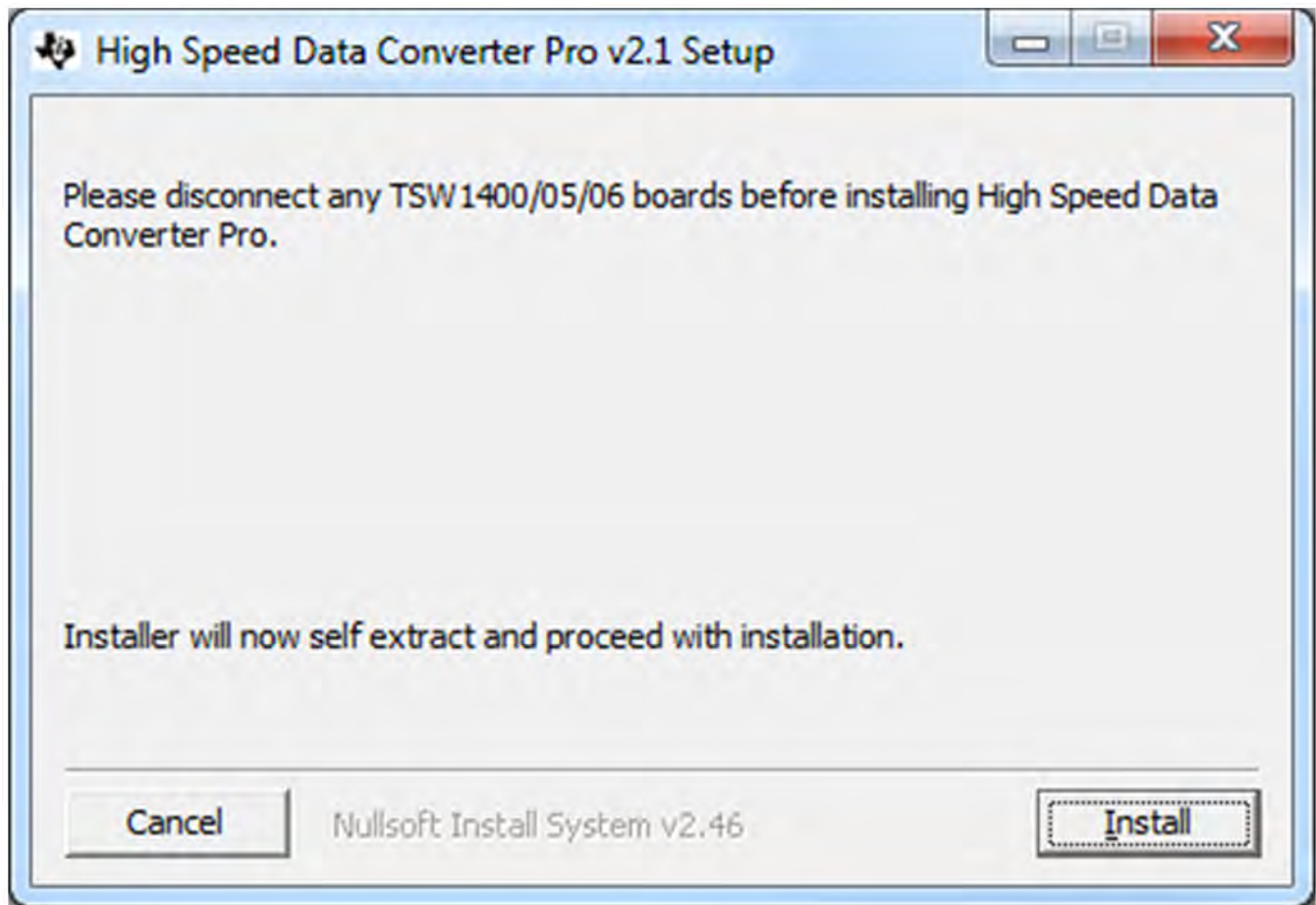

**Figure 27. HSDCPro Install (Begin)**

- Leave the destination directories as the default location, for the TSW1400GUI installation and press the NEXT button as shown in [Figure 28](#).

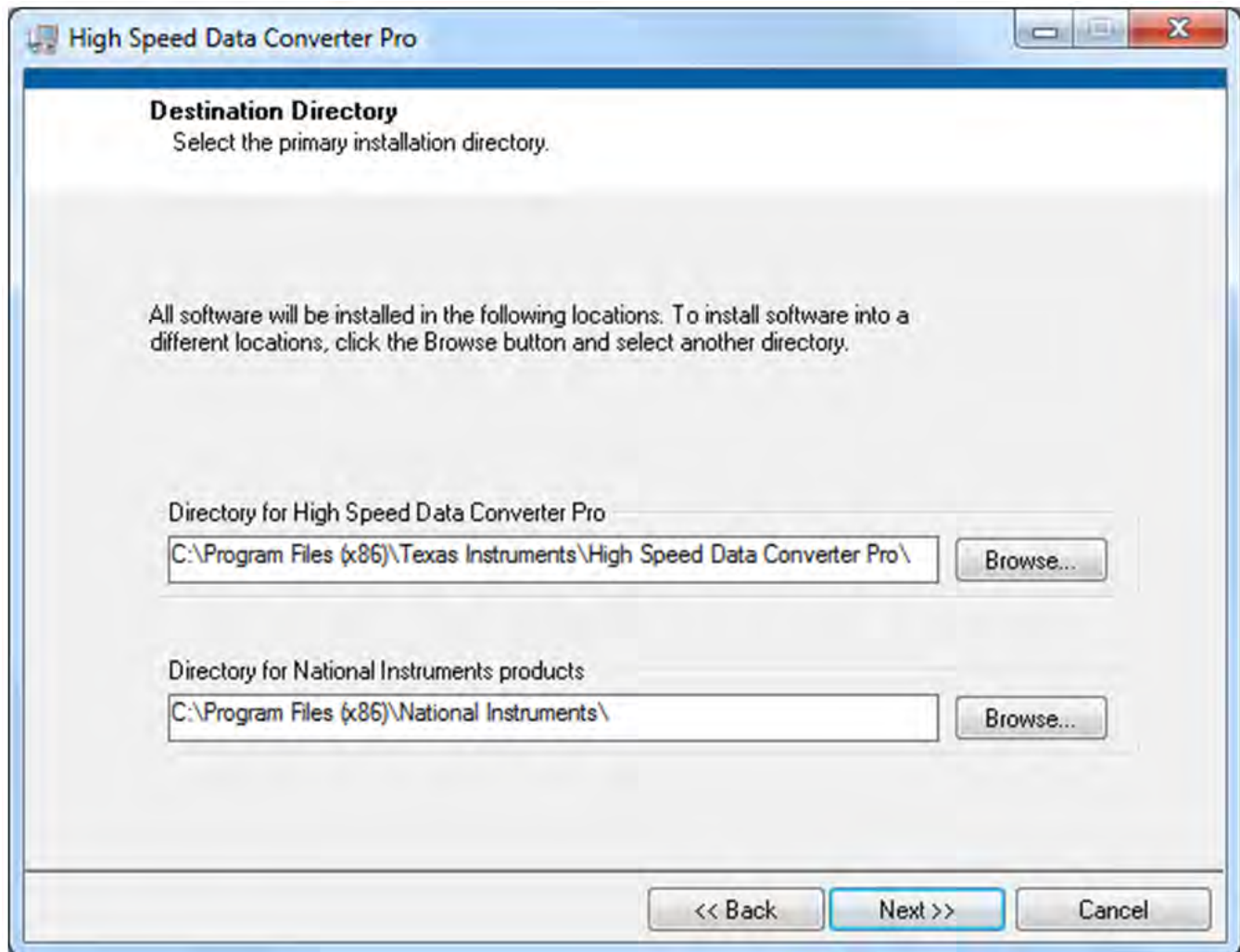

**Figure 28. HSDCPro Install (Install Directory)**

- Read the License Agreement from Texas Instruments and select *I accept the License Agreement* and press the *Next* button as shown in [Figure 29](#).

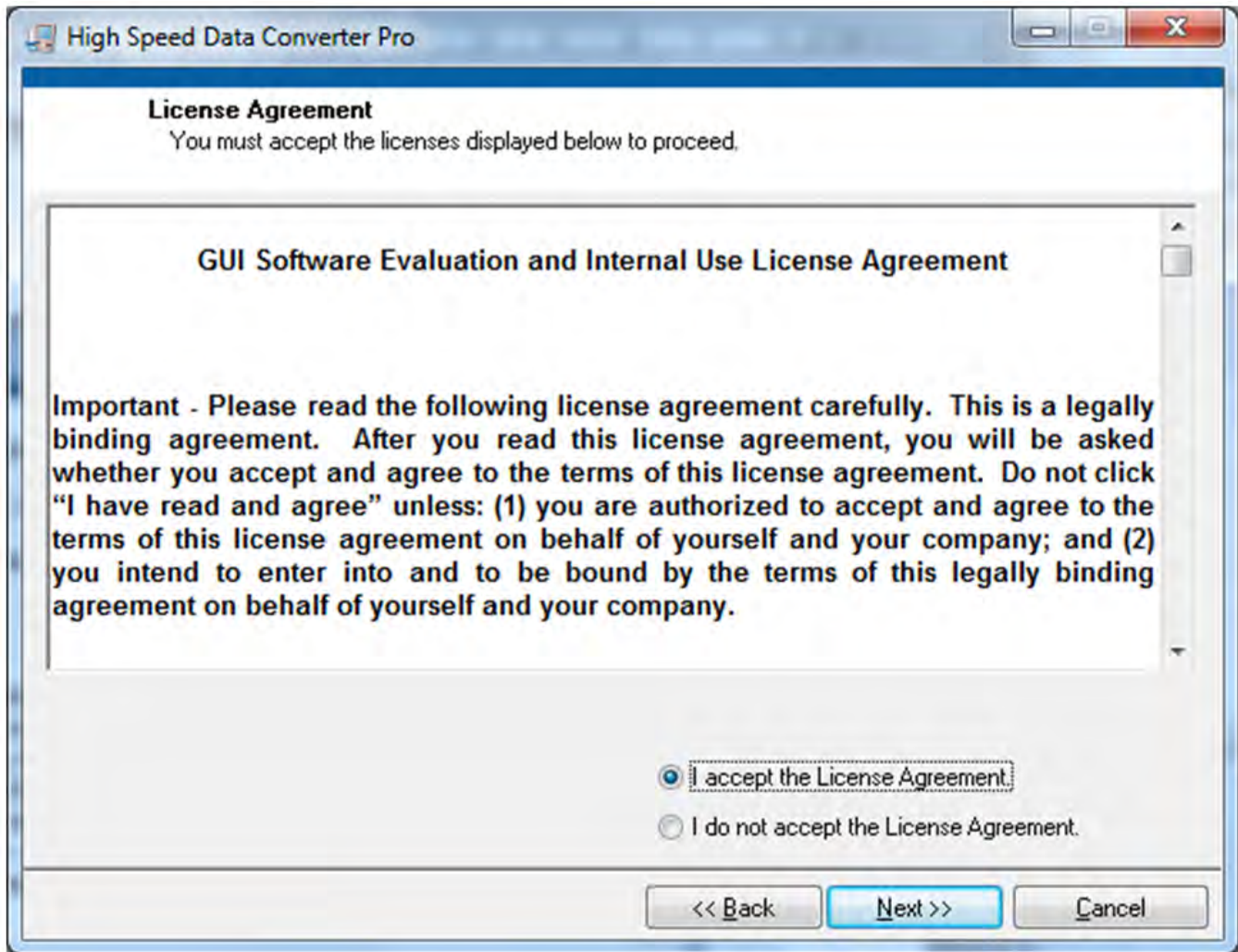

**Figure 29. HSDCPro Install (TI License Agreement)**

- Read the License Agreement from National Instruments and select *I accept the License Agreement* and press the *Next* button as shown in [Figure 30](#).

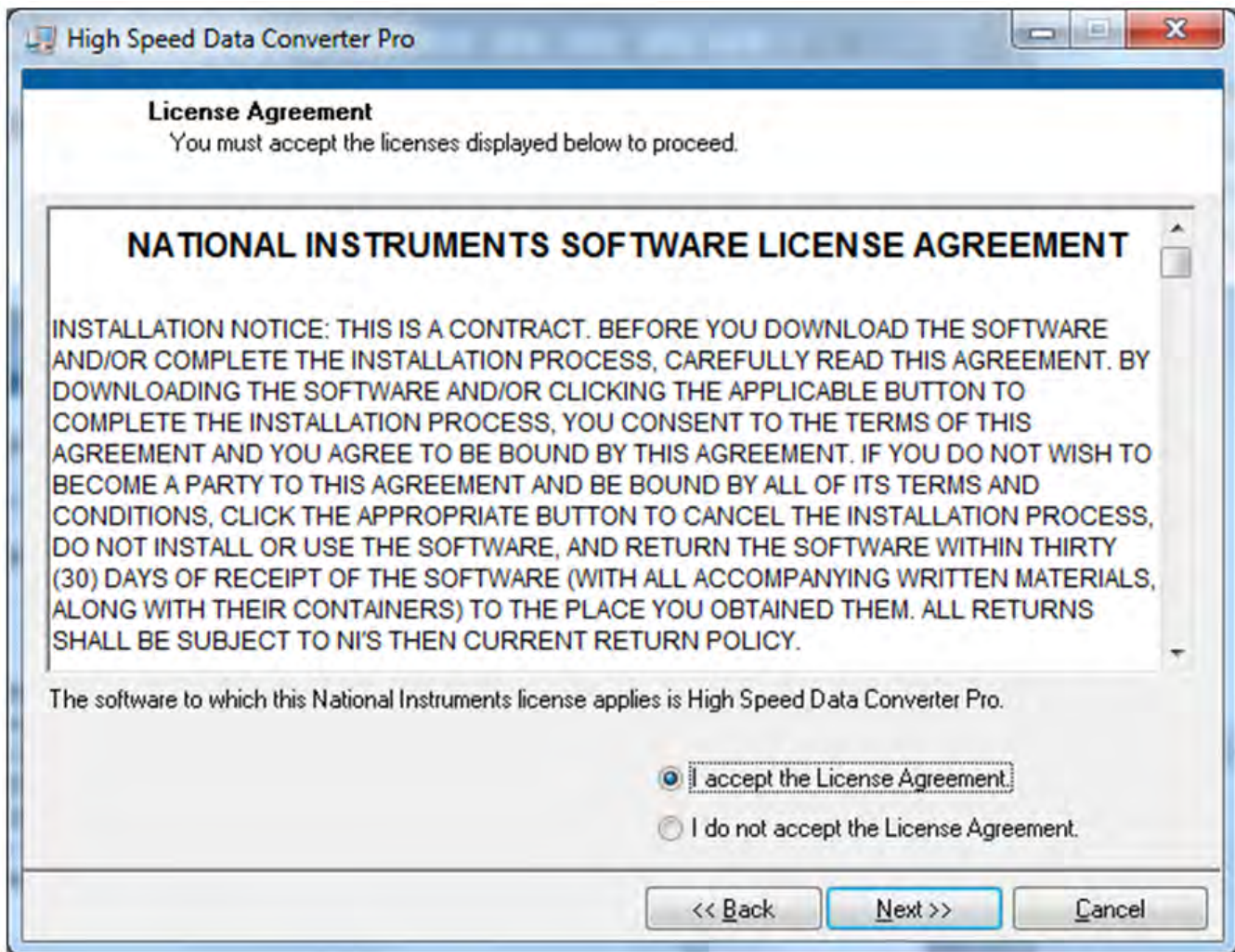

**Figure 30. HSDCPro Install (NI License Agreement)**

- Press the *Next* button as shown in [Figure 31](#).

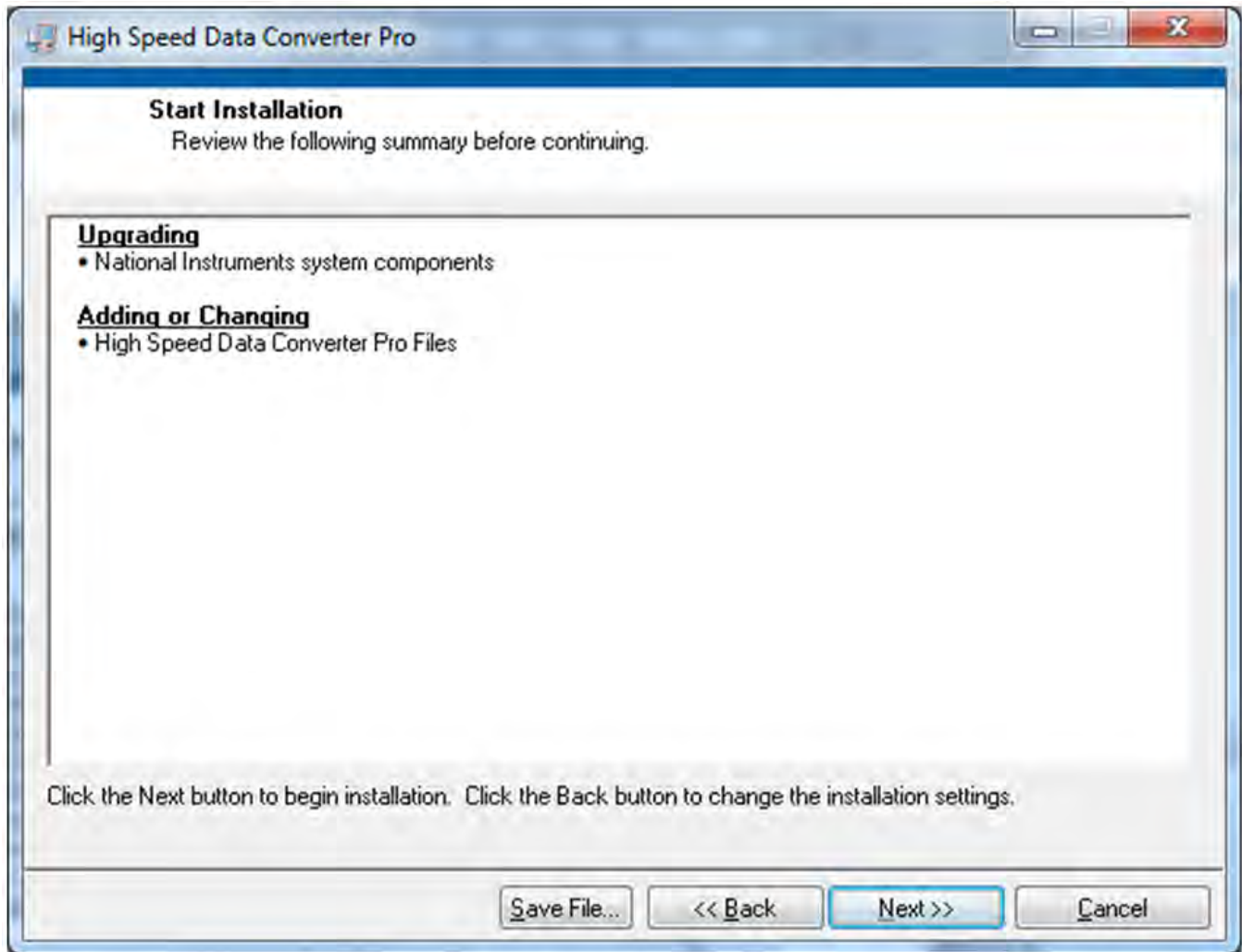

**Figure 31. HSDCPro Install (Start Installation)**

- The window shown in [Figure 32](#) should appear indicating that the installation is in progress.

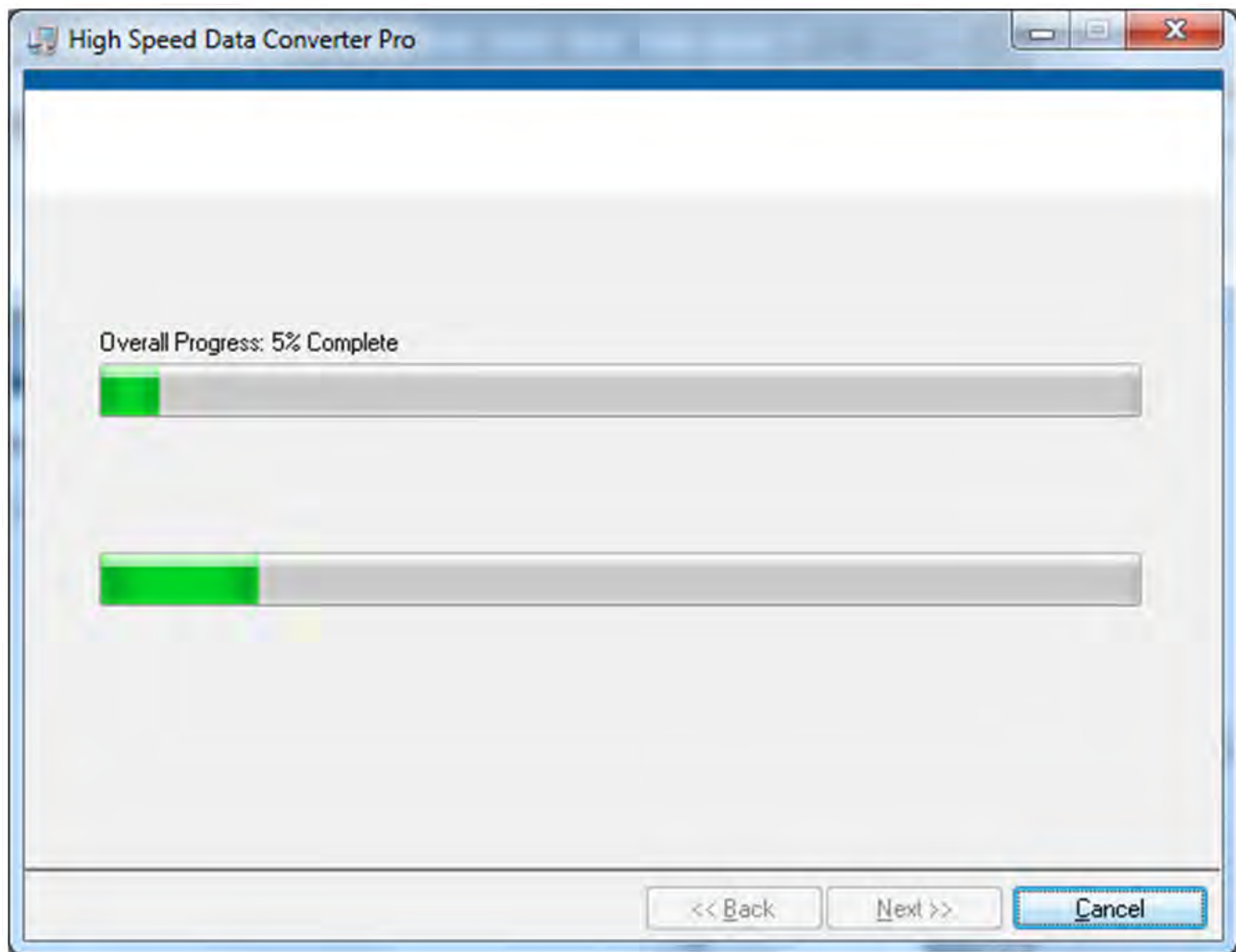

**Figure 32. HSDCPro Install (Installation Progress)**

- The window shown in [Figure 33](#) appears indicating *Installation Complete*. Press the *Next* button.

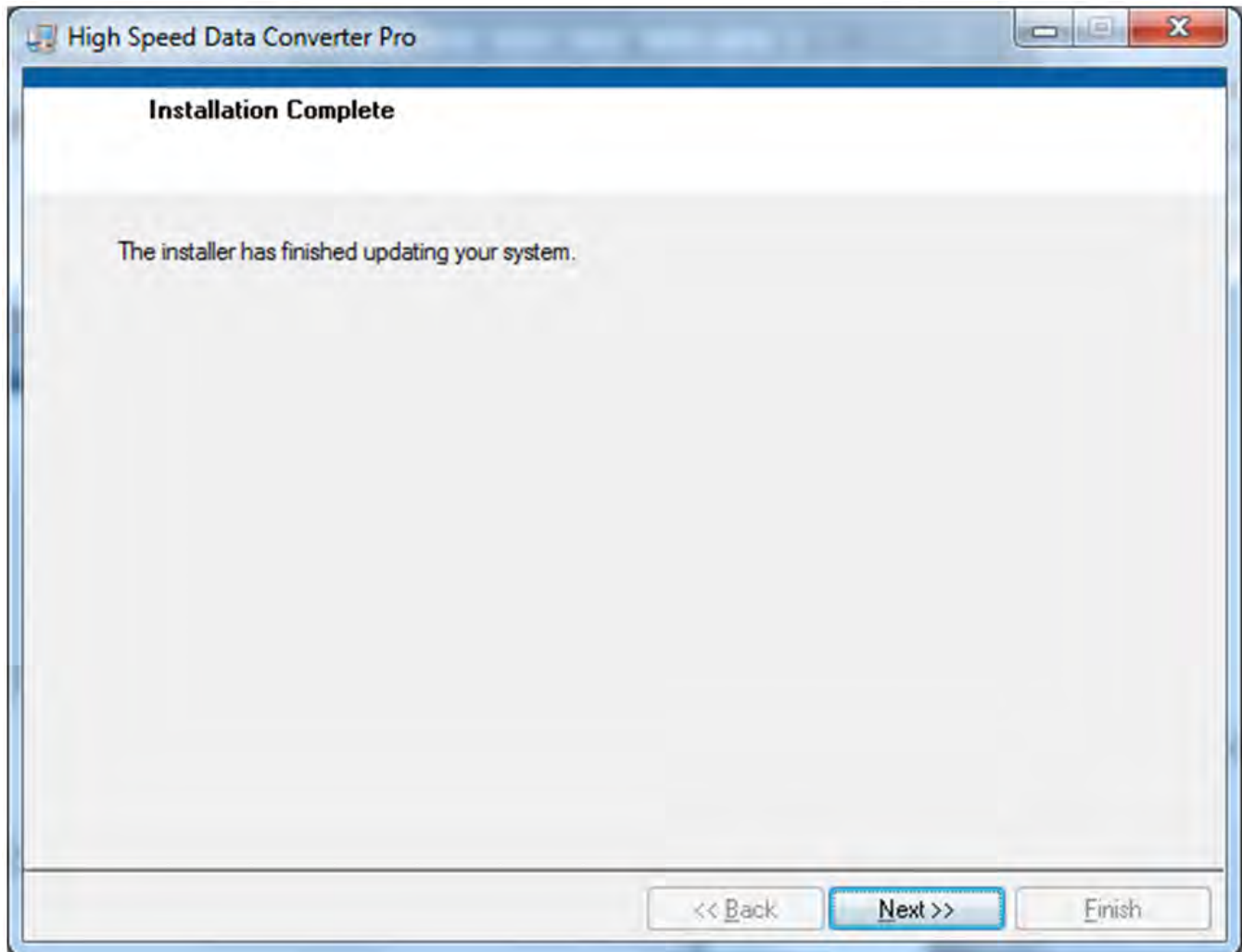

**Figure 33. HSDCPro Install (Installation Complete)**

- The window shown in [Figure 34](#) appears briefly to complete the process.

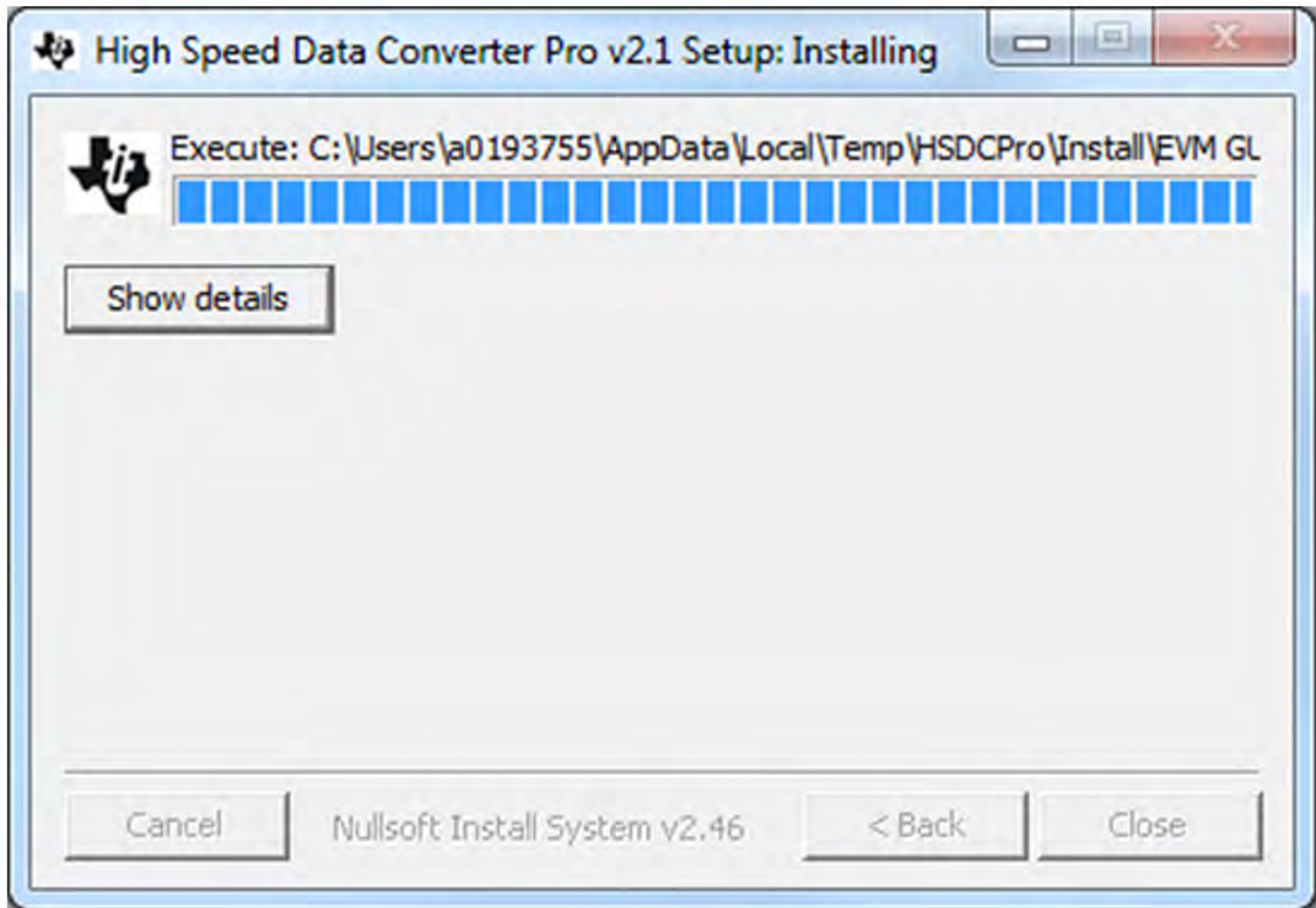

Figure 34. HSDCPro Install (h)

- As shown in Figure 35 a restart might be requested depending on whether or not the PC already had the National Instruments MCR Installer. If requested, hit the *Restart* button to complete the installation.

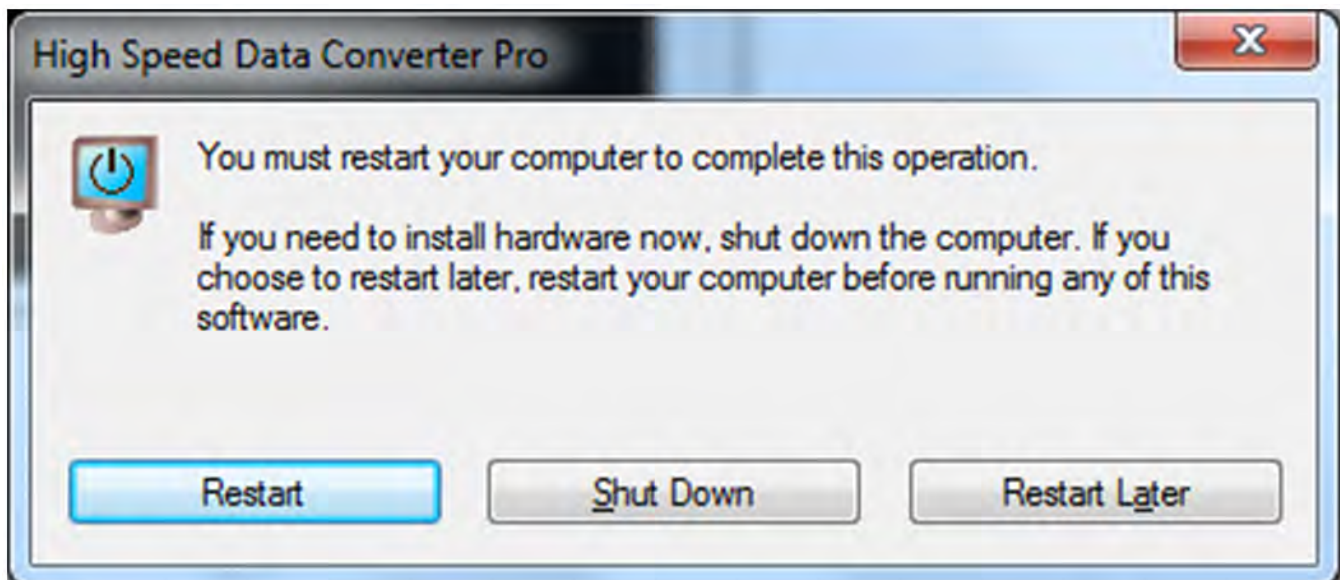

Figure 35. HSDCPro Install

## Revision History

| <b>Changes from A Revision (January 2012) to B Revision</b>  | <b>Page</b> |
|--|-------------|
| • Changed labels and markings on <i>AFE5803EVM Basic Configuration</i> image, board unchanged. ....                        | 3           |
| • Changed labels and markings and board photo on <i>HW Setup With Connection Between TSW1400EVM and AFE5803</i> image..... | 4           |
| • Changed software GUI image in the <i>Launch TSW1400 GUI</i> section. ....  | 7           |
| • Changed software GUI image in the <i>Test AFE5803</i> section. ....  | 8           |
| • Changed software GUI image.....  | 10          |
| • Changed software GUI image illustrating <i>Hanning</i> selection.....  | 11          |
| • Changed software GUI image on step 4 in the <i>External ADC Sampling Clock</i> section. ....                             | 13          |

NOTE: Page numbers for previous revisions may differ from page numbers in the current version.

## STANDARD TERMS AND CONDITIONS FOR EVALUATION MODULES

1. *Delivery:* TI delivers TI evaluation boards, kits, or modules, including any accompanying demonstration software, components, or documentation (collectively, an "EVM" or "EVMs") to the User ("User") in accordance with the terms and conditions set forth herein. Acceptance of the EVM is expressly subject to the following terms and conditions.
  - 1.1 EVMs are intended solely for product or software developers for use in a research and development setting to facilitate feasibility evaluation, experimentation, or scientific analysis of TI semiconductor products. EVMs have no direct function and are not finished products. EVMs shall not be directly or indirectly assembled as a part or subassembly in any finished product. For clarification, any software or software tools provided with the EVM ("Software") shall not be subject to the terms and conditions set forth herein but rather shall be subject to the applicable terms and conditions that accompany such Software
  - 1.2 EVMs are not intended for consumer or household use. EVMs may not be sold, sublicensed, leased, rented, loaned, assigned, or otherwise distributed for commercial purposes by Users, in whole or in part, or used in any finished product or production system.
2. *Limited Warranty and Related Remedies/Disclaimers:*
  - 2.1 These terms and conditions do not apply to Software. The warranty, if any, for Software is covered in the applicable Software License Agreement.
  - 2.2 TI warrants that the TI EVM will conform to TI's published specifications for ninety (90) days after the date TI delivers such EVM to User. Notwithstanding the foregoing, TI shall not be liable for any defects that are caused by neglect, misuse or mistreatment by an entity other than TI, including improper installation or testing, or for any EVMs that have been altered or modified in any way by an entity other than TI. Moreover, TI shall not be liable for any defects that result from User's design, specifications or instructions for such EVMs. Testing and other quality control techniques are used to the extent TI deems necessary or as mandated by government requirements. TI does not test all parameters of each EVM.
  - 2.3 If any EVM fails to conform to the warranty set forth above, TI's sole liability shall be at its option to repair or replace such EVM, or credit User's account for such EVM. TI's liability under this warranty shall be limited to EVMs that are returned during the warranty period to the address designated by TI and that are determined by TI not to conform to such warranty. If TI elects to repair or replace such EVM, TI shall have a reasonable time to repair such EVM or provide replacements. Repaired EVMs shall be warranted for the remainder of the original warranty period. Replaced EVMs shall be warranted for a new full ninety (90) day warranty period.
3. *Regulatory Notices:*
  - 3.1 *United States*
    - 3.1.1 *Notice applicable to EVMs not FCC-Approved:*

This kit is designed to allow product developers to evaluate electronic components, circuitry, or software associated with the kit to determine whether to incorporate such items in a finished product and software developers to write software applications for use with the end product. This kit is not a finished product and when assembled may not be resold or otherwise marketed unless all required FCC equipment authorizations are first obtained. Operation is subject to the condition that this product not cause harmful interference to licensed radio stations and that this product accept harmful interference. Unless the assembled kit is designed to operate under part 15, part 18 or part 95 of this chapter, the operator of the kit must operate under the authority of an FCC license holder or must secure an experimental authorization under part 5 of this chapter.
    - 3.1.2 *For EVMs annotated as FCC – FEDERAL COMMUNICATIONS COMMISSION Part 15 Compliant:*

### CAUTION

This device complies with part 15 of the FCC Rules. Operation is subject to the following two conditions: (1) This device may not cause harmful interference, and (2) this device must accept any interference received, including interference that may cause undesired operation.

Changes or modifications not expressly approved by the party responsible for compliance could void the user's authority to operate the equipment.

### FCC Interference Statement for Class A EVM devices

*NOTE: This equipment has been tested and found to comply with the limits for a Class A digital device, pursuant to part 15 of the FCC Rules. These limits are designed to provide reasonable protection against harmful interference when the equipment is operated in a commercial environment. This equipment generates, uses, and can radiate radio frequency energy and, if not installed and used in accordance with the instruction manual, may cause harmful interference to radio communications. Operation of this equipment in a residential area is likely to cause harmful interference in which case the user will be required to correct the interference at his own expense.*

## **FCC Interference Statement for Class B EVM devices**

*NOTE: This equipment has been tested and found to comply with the limits for a Class B digital device, pursuant to part 15 of the FCC Rules. These limits are designed to provide reasonable protection against harmful interference in a residential installation. This equipment generates, uses and can radiate radio frequency energy and, if not installed and used in accordance with the instructions, may cause harmful interference to radio communications. However, there is no guarantee that interference will not occur in a particular installation. If this equipment does cause harmful interference to radio or television reception, which can be determined by turning the equipment off and on, the user is encouraged to try to correct the interference by one or more of the following measures:*

- Reorient or relocate the receiving antenna.
- Increase the separation between the equipment and receiver.
- Connect the equipment into an outlet on a circuit different from that to which the receiver is connected.
- Consult the dealer or an experienced radio/TV technician for help.

### 3.2 Canada

3.2.1 For EVMs issued with an Industry Canada Certificate of Conformance to RSS-210

#### **Concerning EVMs Including Radio Transmitters:**

This device complies with Industry Canada license-exempt RSS standard(s). Operation is subject to the following two conditions: (1) this device may not cause interference, and (2) this device must accept any interference, including interference that may cause undesired operation of the device.

#### **Concernant les EVMs avec appareils radio:**

Le présent appareil est conforme aux CNR d'Industrie Canada applicables aux appareils radio exempts de licence. L'exploitation est autorisée aux deux conditions suivantes: (1) l'appareil ne doit pas produire de brouillage, et (2) l'utilisateur de l'appareil doit accepter tout brouillage radioélectrique subi, même si le brouillage est susceptible d'en compromettre le fonctionnement.

#### **Concerning EVMs Including Detachable Antennas:**

Under Industry Canada regulations, this radio transmitter may only operate using an antenna of a type and maximum (or lesser) gain approved for the transmitter by Industry Canada. To reduce potential radio interference to other users, the antenna type and its gain should be so chosen that the equivalent isotropically radiated power (e.i.r.p.) is not more than that necessary for successful communication. This radio transmitter has been approved by Industry Canada to operate with the antenna types listed in the user guide with the maximum permissible gain and required antenna impedance for each antenna type indicated. Antenna types not included in this list, having a gain greater than the maximum gain indicated for that type, are strictly prohibited for use with this device.

#### **Concernant les EVMs avec antennes détachables**

Conformément à la réglementation d'Industrie Canada, le présent émetteur radio peut fonctionner avec une antenne d'un type et d'un gain maximal (ou inférieur) approuvé pour l'émetteur par Industrie Canada. Dans le but de réduire les risques de brouillage radioélectrique à l'intention des autres utilisateurs, il faut choisir le type d'antenne et son gain de sorte que la puissance isotrope rayonnée équivalente (p.i.r.e.) ne dépasse pas l'intensité nécessaire à l'établissement d'une communication satisfaisante. Le présent émetteur radio a été approuvé par Industrie Canada pour fonctionner avec les types d'antenne énumérés dans le manuel d'usage et ayant un gain admissible maximal et l'impédance requise pour chaque type d'antenne. Les types d'antenne non inclus dans cette liste, ou dont le gain est supérieur au gain maximal indiqué, sont strictement interdits pour l'exploitation de l'émetteur.

### 3.3 Japan

3.3.1 *Notice for EVMs delivered in Japan:* Please see [http://www.tij.co.jp/lstds/ti\\_ja/general/eStore/notice\\_01.page](http://www.tij.co.jp/lstds/ti_ja/general/eStore/notice_01.page) 日本国内に輸入される評価用キット、ボードについては、次のところをご覧ください。  
[http://www.tij.co.jp/lstds/ti\\_ja/general/eStore/notice\\_01.page](http://www.tij.co.jp/lstds/ti_ja/general/eStore/notice_01.page)

3.3.2 *Notice for Users of EVMs Considered "Radio Frequency Products" in Japan:* EVMs entering Japan are NOT certified by TI as conforming to Technical Regulations of Radio Law of Japan.

If User uses EVMs in Japan, User is required by Radio Law of Japan to follow the instructions below with respect to EVMs:

1. Use EVMs in a shielded room or any other test facility as defined in the notification #173 issued by Ministry of Internal Affairs and Communications on March 28, 2006, based on Sub-section 1.1 of Article 6 of the Ministry's Rule for Enforcement of Radio Law of Japan,
2. Use EVMs only after User obtains the license of Test Radio Station as provided in Radio Law of Japan with respect to EVMs, or
3. Use of EVMs only after User obtains the Technical Regulations Conformity Certification as provided in Radio Law of Japan with respect to EVMs. Also, do not transfer EVMs, unless User gives the same notice above to the transferee. Please note that if User does not follow the instructions above, User will be subject to penalties of Radio Law of Japan.

**【無線電波を送信する製品の開発キットをお使いになる際の注意事項】**

本開発キットは技術基準適合証明を受けておりません。

本製品のご使用に際しては、電波法遵守のため、以下のいずれかの措置を取っていただく必要がありますのでご注意ください。

1. 電波法施行規則第6条第1項第1号に基づく平成18年3月28日総務省告示第173号で定められた電波暗室等の試験設備でご使用いただく。
2. 実験局の免許を取得後ご使用いただく。
3. 技術基準適合証明を取得後ご使用いただく。

なお、本製品は、上記の「ご使用にあたっての注意」を譲渡先、移転先に通知しない限り、譲渡、移転できないものとします。

上記を遵守頂けない場合は、電波法の罰則が適用される可能性があることをご留意ください。

日本テキサス・インスツルメンツ株式会社

東京都新宿区西新宿 6 丁目 2 4 番 1 号

西新宿三井ビル

3.3.3 *Notice for EVMs for Power Line Communication:* Please see [http://www.tij.co.jp/llds/ti\\_ja/general/eStore/notice\\_02.page](http://www.tij.co.jp/llds/ti_ja/general/eStore/notice_02.page)

電力線搬送波通信についての開発キットをお使いになる際の注意事項については、次のところをご覧ください。[http://www.tij.co.jp/llds/ti\\_ja/general/eStore/notice\\_02.page](http://www.tij.co.jp/llds/ti_ja/general/eStore/notice_02.page)

4 *EVM Use Restrictions and Warnings:*

4.1 EVMS ARE NOT FOR USE IN FUNCTIONAL SAFETY AND/OR SAFETY CRITICAL EVALUATIONS, INCLUDING BUT NOT LIMITED TO EVALUATIONS OF LIFE SUPPORT APPLICATIONS.

4.2 User must read and apply the user guide and other available documentation provided by TI regarding the EVM prior to handling or using the EVM, including without limitation any warning or restriction notices. The notices contain important safety information related to, for example, temperatures and voltages.

4.3 *Safety-Related Warnings and Restrictions:*

4.3.1 User shall operate the EVM within TI's recommended specifications and environmental considerations stated in the user guide, other available documentation provided by TI, and any other applicable requirements and employ reasonable and customary safeguards. Exceeding the specified performance ratings and specifications (including but not limited to input and output voltage, current, power, and environmental ranges) for the EVM may cause personal injury or death, or property damage. If there are questions concerning performance ratings and specifications, User should contact a TI field representative prior to connecting interface electronics including input power and intended loads. Any loads applied outside of the specified output range may also result in unintended and/or inaccurate operation and/or possible permanent damage to the EVM and/or interface electronics. Please consult the EVM user guide prior to connecting any load to the EVM output. If there is uncertainty as to the load specification, please contact a TI field representative. During normal operation, even with the inputs and outputs kept within the specified allowable ranges, some circuit components may have elevated case temperatures. These components include but are not limited to linear regulators, switching transistors, pass transistors, current sense resistors, and heat sinks, which can be identified using the information in the associated documentation. When working with the EVM, please be aware that the EVM may become very warm.

4.3.2 EVMs are intended solely for use by technically qualified, professional electronics experts who are familiar with the dangers and application risks associated with handling electrical mechanical components, systems, and subsystems. User assumes all responsibility and liability for proper and safe handling and use of the EVM by User or its employees, affiliates, contractors or designees. User assumes all responsibility and liability to ensure that any interfaces (electronic and/or mechanical) between the EVM and any human body are designed with suitable isolation and means to safely limit accessible leakage currents to minimize the risk of electrical shock hazard. User assumes all responsibility and liability for any improper or unsafe handling or use of the EVM by User or its employees, affiliates, contractors or designees.

4.4 User assumes all responsibility and liability to determine whether the EVM is subject to any applicable international, federal, state, or local laws and regulations related to User's handling and use of the EVM and, if applicable, User assumes all responsibility and liability for compliance in all respects with such laws and regulations. User assumes all responsibility and liability for proper disposal and recycling of the EVM consistent with all applicable international, federal, state, and local requirements.

5. *Accuracy of Information:* To the extent TI provides information on the availability and function of EVMs, TI attempts to be as accurate as possible. However, TI does not warrant the accuracy of EVM descriptions, EVM availability or other information on its websites as accurate, complete, reliable, current, or error-free.

6. *Disclaimers:*

6.1 EXCEPT AS SET FORTH ABOVE, EVMS AND ANY WRITTEN DESIGN MATERIALS PROVIDED WITH THE EVM (AND THE DESIGN OF THE EVM ITSELF) ARE PROVIDED "AS IS" AND "WITH ALL FAULTS." TI DISCLAIMS ALL OTHER WARRANTIES, EXPRESS OR IMPLIED, REGARDING SUCH ITEMS, INCLUDING BUT NOT LIMITED TO ANY IMPLIED WARRANTIES OF MERCHANTABILITY OR FITNESS FOR A PARTICULAR PURPOSE OR NON-INFRINGEMENT OF ANY THIRD PARTY PATENTS, COPYRIGHTS, TRADE SECRETS OR OTHER INTELLECTUAL PROPERTY RIGHTS.

6.2 EXCEPT FOR THE LIMITED RIGHT TO USE THE EVM SET FORTH HEREIN, NOTHING IN THESE TERMS AND CONDITIONS SHALL BE CONSTRUED AS GRANTING OR CONFERRING ANY RIGHTS BY LICENSE, PATENT, OR ANY OTHER INDUSTRIAL OR INTELLECTUAL PROPERTY RIGHT OF TI, ITS SUPPLIERS/LICENSORS OR ANY OTHER THIRD PARTY, TO USE THE EVM IN ANY FINISHED END-USER OR READY-TO-USE FINAL PRODUCT, OR FOR ANY INVENTION, DISCOVERY OR IMPROVEMENT MADE, CONCEIVED OR ACQUIRED PRIOR TO OR AFTER DELIVERY OF THE EVM.

7. *USER'S INDEMNITY OBLIGATIONS AND REPRESENTATIONS.* USER WILL DEFEND, INDEMNIFY AND HOLD TI, ITS LICENSORS AND THEIR REPRESENTATIVES HARMLESS FROM AND AGAINST ANY AND ALL CLAIMS, DAMAGES, LOSSES, EXPENSES, COSTS AND LIABILITIES (COLLECTIVELY, "CLAIMS") ARISING OUT OF OR IN CONNECTION WITH ANY HANDLING OR USE OF THE EVM THAT IS NOT IN ACCORDANCE WITH THESE TERMS AND CONDITIONS. THIS OBLIGATION SHALL APPLY WHETHER CLAIMS ARISE UNDER STATUTE, REGULATION, OR THE LAW OF TORT, CONTRACT OR ANY OTHER LEGAL THEORY, AND EVEN IF THE EVM FAILS TO PERFORM AS DESCRIBED OR EXPECTED.

8. *Limitations on Damages and Liability:*

8.1 *General Limitations.* IN NO EVENT SHALL TI BE LIABLE FOR ANY SPECIAL, COLLATERAL, INDIRECT, PUNITIVE, INCIDENTAL, CONSEQUENTIAL, OR EXEMPLARY DAMAGES IN CONNECTION WITH OR ARISING OUT OF THESE TERMS AND CONDITIONS OR THE USE OF THE EVMS PROVIDED HEREUNDER, REGARDLESS OF WHETHER TI HAS BEEN ADVISED OF THE POSSIBILITY OF SUCH DAMAGES. EXCLUDED DAMAGES INCLUDE, BUT ARE NOT LIMITED TO, COST OF REMOVAL OR REINSTALLATION, ANCILLARY COSTS TO THE PROCUREMENT OF SUBSTITUTE GOODS OR SERVICES, RETESTING, OUTSIDE COMPUTER TIME, LABOR COSTS, LOSS OF GOODWILL, LOSS OF PROFITS, LOSS OF SAVINGS, LOSS OF USE, LOSS OF DATA, OR BUSINESS INTERRUPTION. NO CLAIM, SUIT OR ACTION SHALL BE BROUGHT AGAINST TI MORE THAN ONE YEAR AFTER THE RELATED CAUSE OF ACTION HAS OCCURRED.

8.2 *Specific Limitations.* IN NO EVENT SHALL TI'S AGGREGATE LIABILITY FROM ANY WARRANTY OR OTHER OBLIGATION ARISING OUT OF OR IN CONNECTION WITH THESE TERMS AND CONDITIONS, OR ANY USE OF ANY TI EVM PROVIDED HEREUNDER, EXCEED THE TOTAL AMOUNT PAID TO TI FOR THE PARTICULAR UNITS SOLD UNDER THESE TERMS AND CONDITIONS WITH RESPECT TO WHICH LOSSES OR DAMAGES ARE CLAIMED. THE EXISTENCE OF MORE THAN ONE CLAIM AGAINST THE PARTICULAR UNITS SOLD TO USER UNDER THESE TERMS AND CONDITIONS SHALL NOT ENLARGE OR EXTEND THIS LIMIT.

9. *Return Policy.* Except as otherwise provided, TI does not offer any refunds, returns, or exchanges. Furthermore, no return of EVM(s) will be accepted if the package has been opened and no return of the EVM(s) will be accepted if they are damaged or otherwise not in a resalable condition. If User feels it has been incorrectly charged for the EVM(s) it ordered or that delivery violates the applicable order, User should contact TI. All refunds will be made in full within thirty (30) working days from the return of the components(s), excluding any postage or packaging costs.

10. *Governing Law:* These terms and conditions shall be governed by and interpreted in accordance with the laws of the State of Texas, without reference to conflict-of-laws principles. User agrees that non-exclusive jurisdiction for any dispute arising out of or relating to these terms and conditions lies within courts located in the State of Texas and consents to venue in Dallas County, Texas. Notwithstanding the foregoing, any judgment may be enforced in any United States or foreign court, and TI may seek injunctive relief in any United States or foreign court.

## IMPORTANT NOTICE

Texas Instruments Incorporated and its subsidiaries (TI) reserve the right to make corrections, enhancements, improvements and other changes to its semiconductor products and services per JESD46, latest issue, and to discontinue any product or service per JESD48, latest issue. Buyers should obtain the latest relevant information before placing orders and should verify that such information is current and complete. All semiconductor products (also referred to herein as "components") are sold subject to TI's terms and conditions of sale supplied at the time of order acknowledgment.

TI warrants performance of its components to the specifications applicable at the time of sale, in accordance with the warranty in TI's terms and conditions of sale of semiconductor products. Testing and other quality control techniques are used to the extent TI deems necessary to support this warranty. Except where mandated by applicable law, testing of all parameters of each component is not necessarily performed.

TI assumes no liability for applications assistance or the design of Buyers' products. Buyers are responsible for their products and applications using TI components. To minimize the risks associated with Buyers' products and applications, Buyers should provide adequate design and operating safeguards.

TI does not warrant or represent that any license, either express or implied, is granted under any patent right, copyright, mask work right, or other intellectual property right relating to any combination, machine, or process in which TI components or services are used. Information published by TI regarding third-party products or services does not constitute a license to use such products or services or a warranty or endorsement thereof. Use of such information may require a license from a third party under the patents or other intellectual property of the third party, or a license from TI under the patents or other intellectual property of TI.

Reproduction of significant portions of TI information in TI data books or data sheets is permissible only if reproduction is without alteration and is accompanied by all associated warranties, conditions, limitations, and notices. TI is not responsible or liable for such altered documentation. Information of third parties may be subject to additional restrictions.

Resale of TI components or services with statements different from or beyond the parameters stated by TI for that component or service voids all express and any implied warranties for the associated TI component or service and is an unfair and deceptive business practice. TI is not responsible or liable for any such statements.

Buyer acknowledges and agrees that it is solely responsible for compliance with all legal, regulatory and safety-related requirements concerning its products, and any use of TI components in its applications, notwithstanding any applications-related information or support that may be provided by TI. Buyer represents and agrees that it has all the necessary expertise to create and implement safeguards which anticipate dangerous consequences of failures, monitor failures and their consequences, lessen the likelihood of failures that might cause harm and take appropriate remedial actions. Buyer will fully indemnify TI and its representatives against any damages arising out of the use of any TI components in safety-critical applications.

In some cases, TI components may be promoted specifically to facilitate safety-related applications. With such components, TI's goal is to help enable customers to design and create their own end-product solutions that meet applicable functional safety standards and requirements. Nonetheless, such components are subject to these terms.

No TI components are authorized for use in FDA Class III (or similar life-critical medical equipment) unless authorized officers of the parties have executed a special agreement specifically governing such use.

Only those TI components which TI has specifically designated as military grade or "enhanced plastic" are designed and intended for use in military/aerospace applications or environments. Buyer acknowledges and agrees that any military or aerospace use of TI components which have **not** been so designated is solely at the Buyer's risk, and that Buyer is solely responsible for compliance with all legal and regulatory requirements in connection with such use.

TI has specifically designated certain components as meeting ISO/TS16949 requirements, mainly for automotive use. In any case of use of non-designated products, TI will not be responsible for any failure to meet ISO/TS16949.

### Products

|                              |  |
|------------------------------|--|
| Audio                        | <a href="http://www.ti.com/audio">www.ti.com/audio</a>                               |
| Amplifiers                   | <a href="http://amplifier.ti.com">amplifier.ti.com</a>                               |
| Data Converters              | <a href="http://dataconverter.ti.com">dataconverter.ti.com</a>                       |
| DLP® Products                | <a href="http://www.dlp.com">www.dlp.com</a>   |
| DSP                          | <a href="http://dsp.ti.com">dsp.ti.com</a>   |
| Clocks and Timers            | <a href="http://www.ti.com/clocks">www.ti.com/clocks</a>                             |
| Interface                    | <a href="http://interface.ti.com">interface.ti.com</a>                               |
| Logic                        | <a href="http://logic.ti.com">logic.ti.com</a>                                       |
| Power Mgmt                   | <a href="http://power.ti.com">power.ti.com</a>                                       |
| Microcontrollers             | <a href="http://microcontroller.ti.com">microcontroller.ti.com</a>                   |
| RFID                         | <a href="http://www.ti-rfid.com">www.ti-rfid.com</a>                                 |
| OMAP Applications Processors | <a href="http://www.ti.com/omap">www.ti.com/omap</a>                                 |
| Wireless Connectivity        | <a href="http://www.ti.com/wirelessconnectivity">www.ti.com/wirelessconnectivity</a> |

### Applications

|                               |  |
|-------------------------------|--|
| Automotive and Transportation | <a href="http://www.ti.com/automotive">www.ti.com/automotive</a>                         |
| Communications and Telecom    | <a href="http://www.ti.com/communications">www.ti.com/communications</a>                 |
| Computers and Peripherals     | <a href="http://www.ti.com/computers">www.ti.com/computers</a>                           |
| Consumer Electronics          | <a href="http://www.ti.com/consumer-apps">www.ti.com/consumer-apps</a>                   |
| Energy and Lighting           | <a href="http://www.ti.com/energy">www.ti.com/energy</a>                                 |
| Industrial                    | <a href="http://www.ti.com/industrial">www.ti.com/industrial</a>                         |
| Medical                       | <a href="http://www.ti.com/medical">www.ti.com/medical</a>                               |
| Security                      | <a href="http://www.ti.com/security">www.ti.com/security</a>                             |
| Space, Avionics and Defense   | <a href="http://www.ti.com/space-avionics-defense">www.ti.com/space-avionics-defense</a> |
| Video and Imaging             | <a href="http://www.ti.com/video">www.ti.com/video</a>                                   |

### TI E2E Community

[e2e.ti.com](http://e2e.ti.com)