

Introduction

The SPC560P-DISP Discovery kit helps you to discover SPC56 P line Power Architecture[®] Microcontrollers.

The discovery board is based on SPC560P50L5, 64 MHz, single issue, 32-bit CPU core complex (e200z0h) CPU core with 574KB flash in an LQFP144 package.

The numerous interfaces including GPI/O's, peripherals such as CAN, JTAG, K-Line, LIN, FlexCAN and GPIOs make the SPC560P-DISP an excellent starter kit for customer quick evaluation and project development.

Dedicated connectors allow plugging Arduino shields (Arduino-compatible).

The SPC560 P line is designed to address cost sensitive chassis, airbag, electrical hydraulic power steering (EHPS), electric power steering (EPS), and electrical motor control applications.

Free ready-to-run application firmware examples are available inside SPC5Studio (www.st.com/spc5studio) to support quick evaluation and development.

Contents

- 1 SPC560P-DISP Discovery+ board 5**
 - 1.1 Debug interface 5
 - 1.2 I/O interface and connectors 5

- 2 Hardware overview 6**
 - 2.1 Power Supply section 6
 - 2.1.1 5 VDC power supply 7
 - 2.1.2 3.3 VDC power supply 8
 - 2.1.3 Power supply using USB connection 8
 - 2.1.4 Automatic DC source selector 9
 - 2.2 Crystal oscillator 9
 - 2.3 Reset section 10
 - 2.4 User LEDs 10
 - 2.5 ADC reference 10
 - 2.6 Integrated USB programmer/debugger11
 - 2.7 JTAG connectors 13
 - 2.8 FlexCAN interface and Safety Port 15
 - 2.9 FlexRay interface 15
 - 2.10 LINFlex communication (Serial Communication Interface module) 16
 - 2.11 Connectors Arduino-compatible 17
 - 2.12 I/O header 18

- 3 PCB layout 21**

- Appendix A General handling precautions 22**

- Revision history 23**



List of tables

Table 1.	PSU Section - LEDs	7
Table 2.	User LEDs	10
Table 3.	JTAG connector (X1 and X2)	14
Table 4.	I/O header (Schematic diagram).....	19
Table 5.	Document revision history	23

List of figures

Figure 1.	SPC560P-DISP Discovery+ board	5
Figure 2.	SPC560P-DISP - hw overview	6
Figure 3.	PSU section (PCB top side)	6
Figure 4.	PSU section (PCB bottom side)	7
Figure 5.	PSU section (Vout: 5.0 V _{DC})	8
Figure 6.	PSU section (Vout: 3.3 V _{DC})	8
Figure 7.	USB connection - 3.3 V _{DC}	8
Figure 8.	Automatic DC source selector	9
Figure 9.	Crystal oscillator	9
Figure 10.	Reset section	10
Figure 11.	User LEDs	10
Figure 12.	ADC reference	11
Figure 13.	Integrated debugger – USB input	12
Figure 14.	Integrated debugger – EEPROM	12
Figure 15.	Integrated debugger - Level Shifters	13
Figure 16.	Integrated debugger - LEDs	13
Figure 17.	JTAG connectors	14
Figure 18.	FlexCAN - jumpers configuration	15
Figure 19.	High Speed CAN and FlexRay	15
Figure 20.	FlexRay – jumper configuration	16
Figure 21.	FlexRay transceiver and connector	16
Figure 22.	LINFlex communication (I)	17
Figure 23.	LINFlex communication (I)	17
Figure 24.	Connectors Arduino-compatible (I)	17
Figure 25.	Connectors Arduino-compatible (II)	18
Figure 26.	Connectors Arduino-compatible (III)	18
Figure 27.	Connectors Arduino-compatible (IV)	18
Figure 28.	I/O header (Schematic diagram)	19
Figure 29.	PCB layout	21

1 SPC560P-DISP Discovery+ board

Figure 1. SPC560P-DISP Discovery+ board

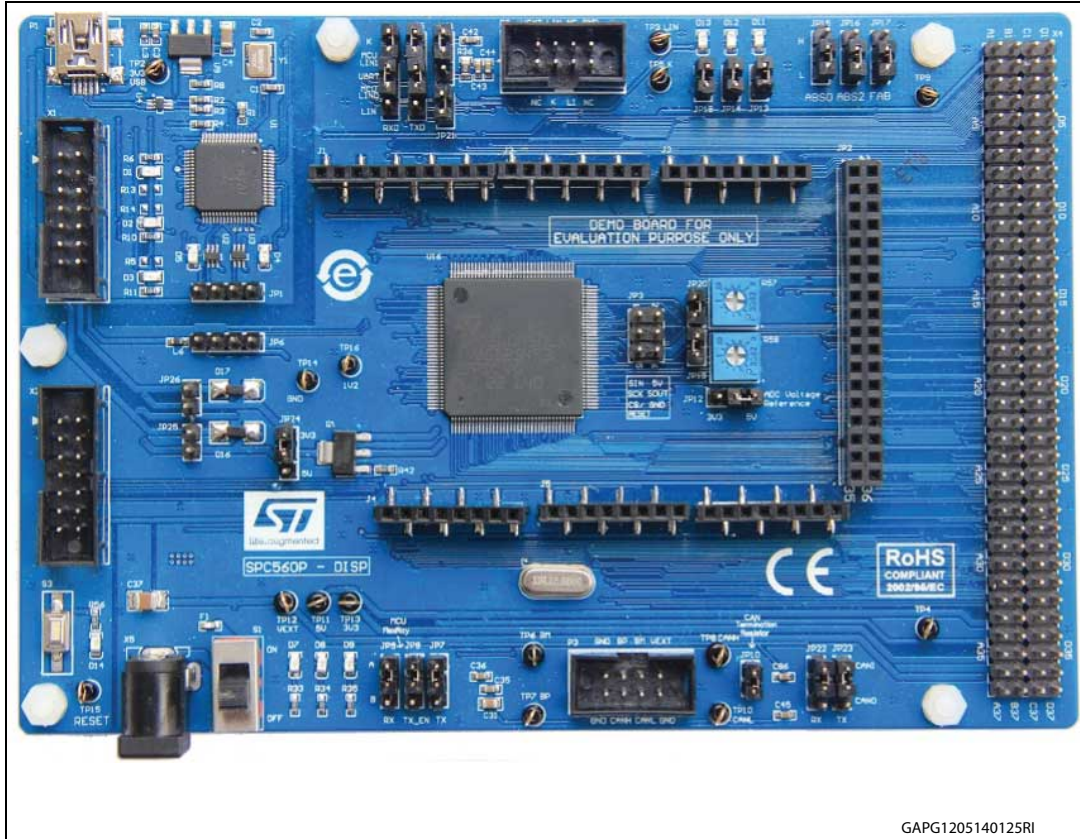

GAPG1205140125RI

The PCB, the components and all HW parts assembled in the board meet requirements of the applicable RoHS directives.

1.1 Debug interface

- Double 2x7-pin JTAG interfaces
- USB mini B and integrated programmer/debugger

1.2 I/O interface and connectors

- PSU plug (+12V)
- FlexCAN interface
- FlexRay
- K-Line
- LINFlex
- Arduino connectors (Arduino compatibility)
- 4x37 headers

2 Hardware overview

Figure 2. SPC560P-DISP - hw overview

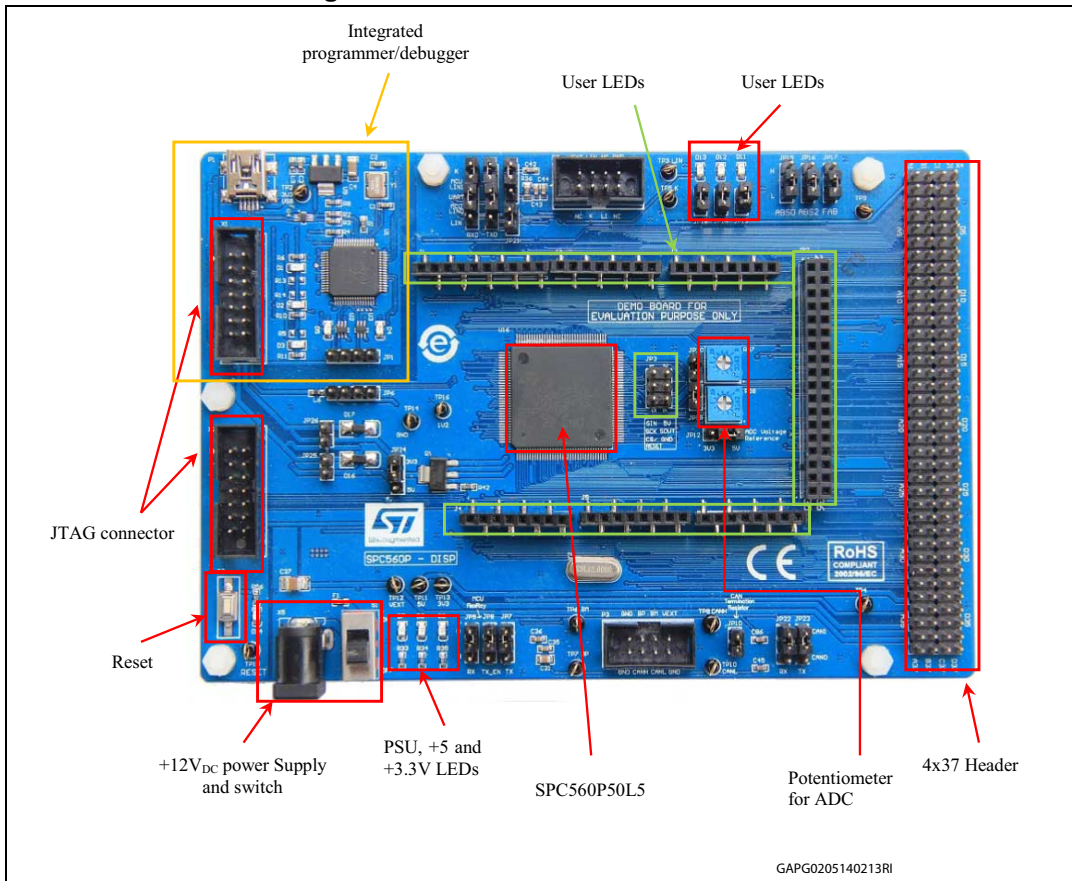

2.1 Power Supply section

Figure 3. PSU section (PCB top side)

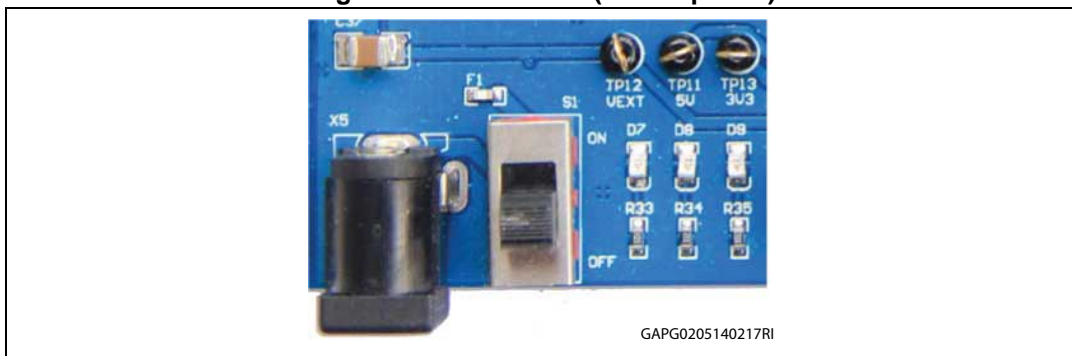

Figure 4. PSU section (PCB bottom side)

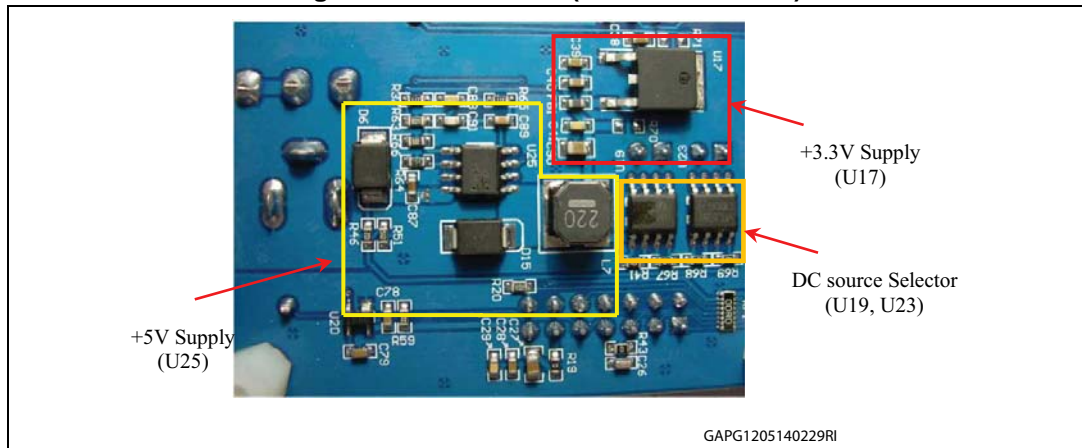

Table 1. PSU Section - LEDs

Item	Color	Function
D7	Green	Vext (+12V)
D8	Green	5V
D9	Green	3.3V
D3	Green	VCIO

2.1.1 5 V_{DC} power supply

This section is only used when an external 12V PSU is connected to the X5 DC port^(a) (X5). The diode D6 is used to protect the board against reverse polarity and AC source. The fuse F1 protects the board when an accidental short circuit occurs.

The LED D7 is switched on when the board is correctly powered and the switch S1 is set to ON position.

The 5V generator is based on the ST device A7985; [Figure 5](#) shows the circuit diagram.

a. The external 12V PSU adapter is not included in the evaluation kit

Figure 5. PSU section (Vout: 5.0 V_{DC})

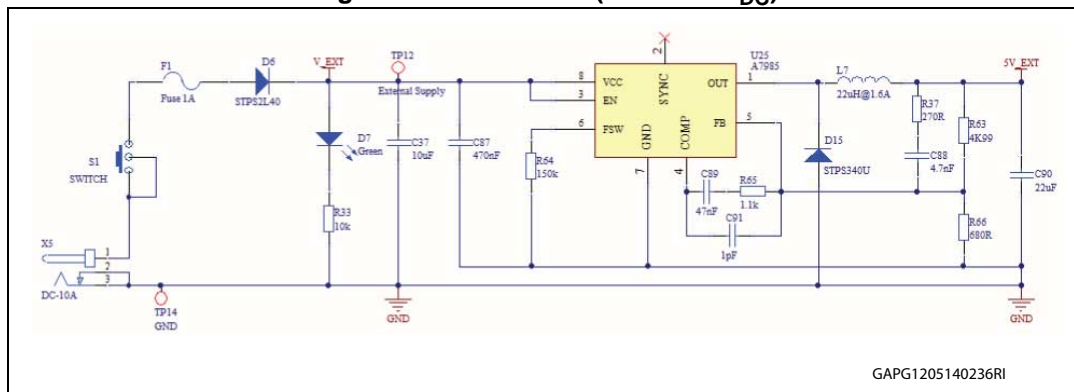

2.1.2 3.3 V_{DC} power supply

The liner regulator LD1117-3V3 is used to generate the 3.3 V supply voltage; *Figure 6* shows the schematic diagram.

Figure 6. PSU section (Vout: 3.3 V_{DC})

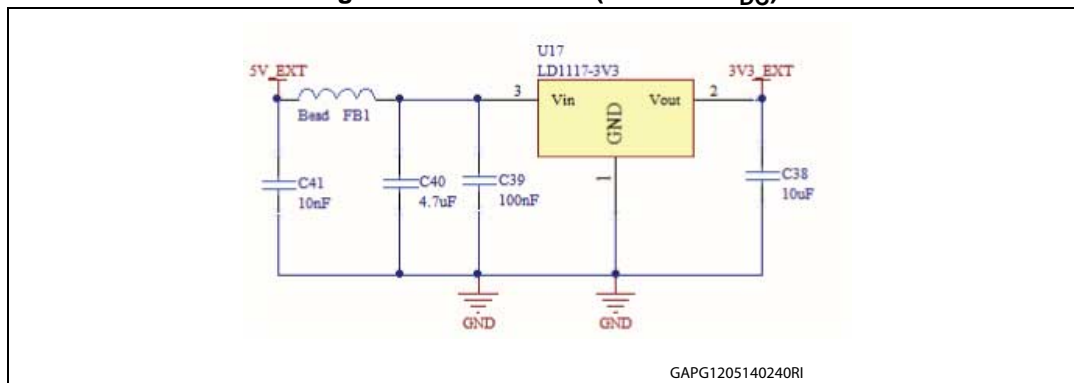

2.1.3 Power supply using USB connection

The board can be supplied by the USB cable when the internal programmer/debugger is used; in this working condition 3.3 V is generated using a liner regulator (*Figure 7*).

Figure 7. USB connection - 3.3 V_{DC}

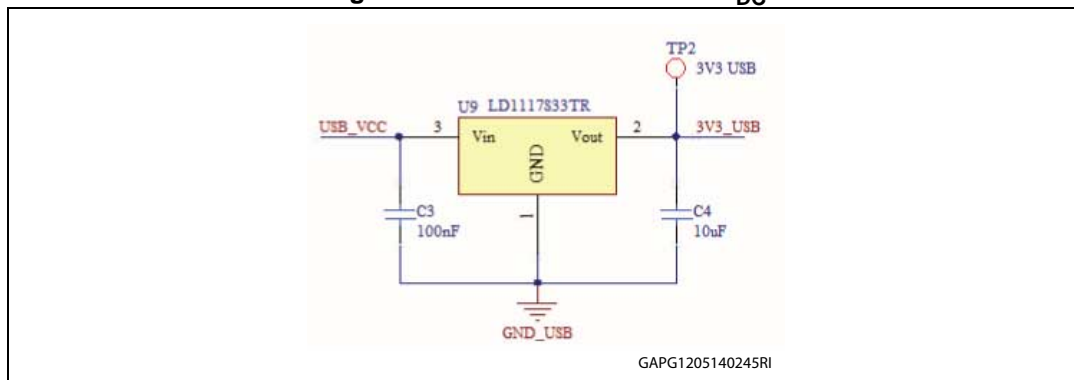

2.1.4 Automatic DC source selector

The circuit in *Figure 8* switches 5 V and 3.3 V automatically when the board is supplied by an external PSU or by 5V from the PC/USB cable. The voltage divider made by R46 and R51 is used to sense the presence of an external PSU (5V is sensed) and it drives U19 and U23 properly.

Figure 8. Automatic DC source selector

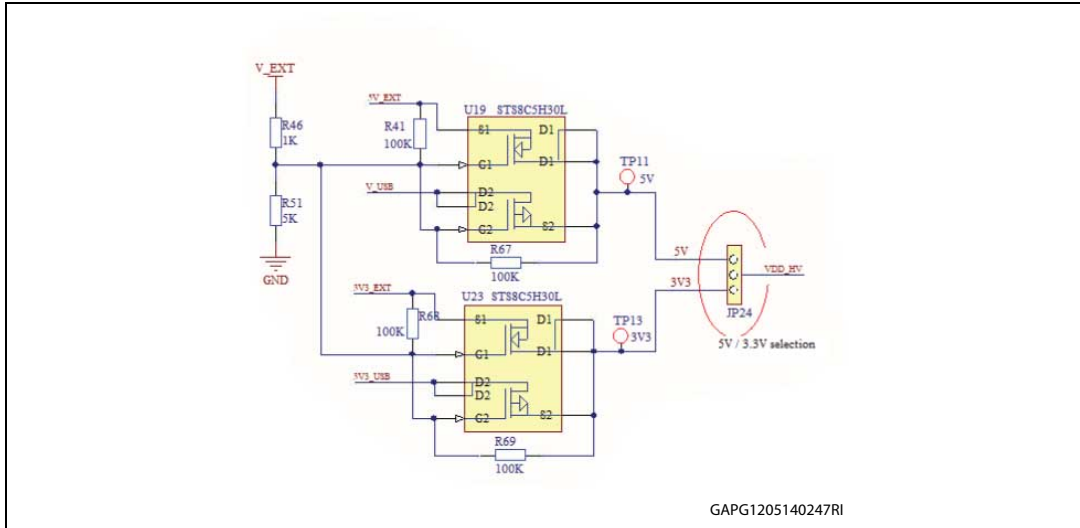

The jumper JP24 allows selecting the VDD_HV level: 3.3 V or 5 V.

2.2 Crystal oscillator

The SPC560P-DISP board is populated with 16 MHz crystal to clock the SPC560P50L5.

Figure 9. Crystal oscillator

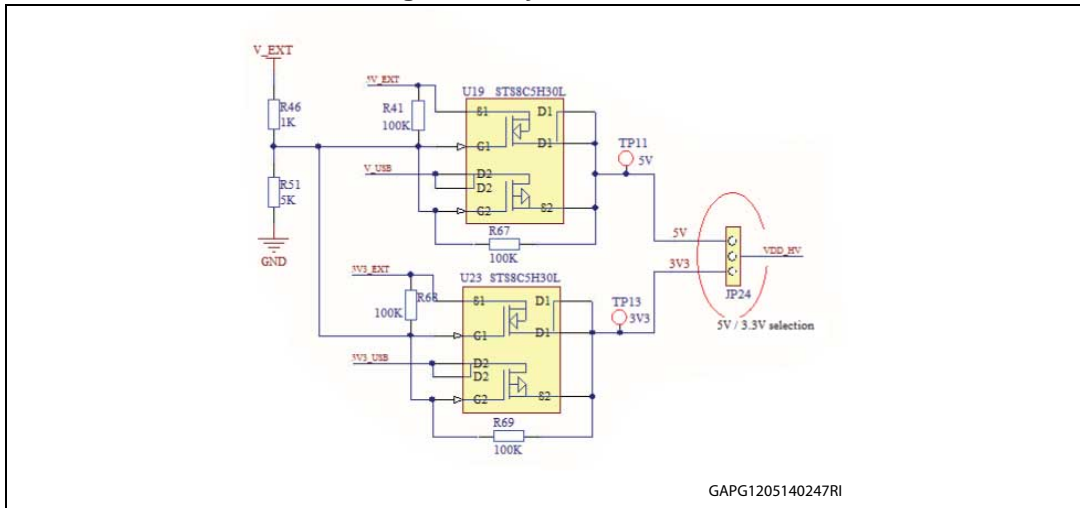

2.3 Reset section

The reset circuit (see *Figure 10*) generates a sharp signal to reset the microcontroller. The core of the circuit is the device STM6315RB-2.63 V; it produces the reset pulse when the S3 button is pushed: D14 is turned on on when the reset pulse is generated.

Figure 10. Reset section

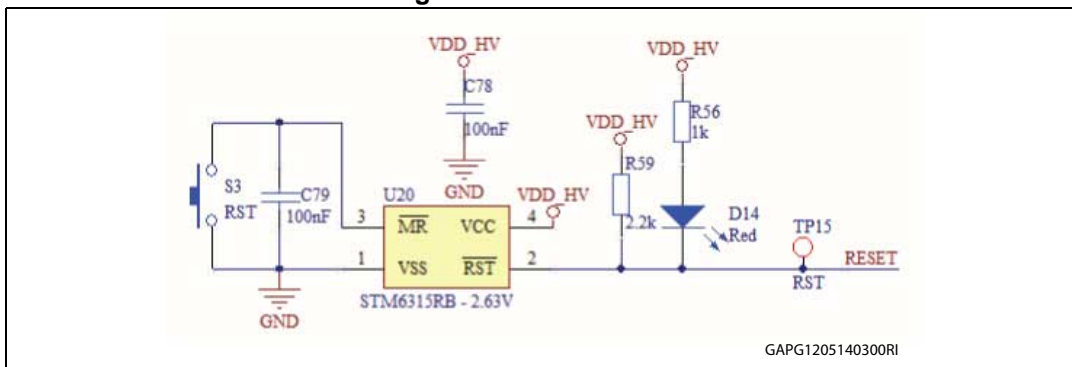

2.4 User LEDs

On the board are present three USER LEDs connected as shown in *Figure 11*. The jumpers JP13, JP14 and JP18 allow disconnecting the LED cathodes and used the GPIO to a different purpose.

Figure 11. User LEDs

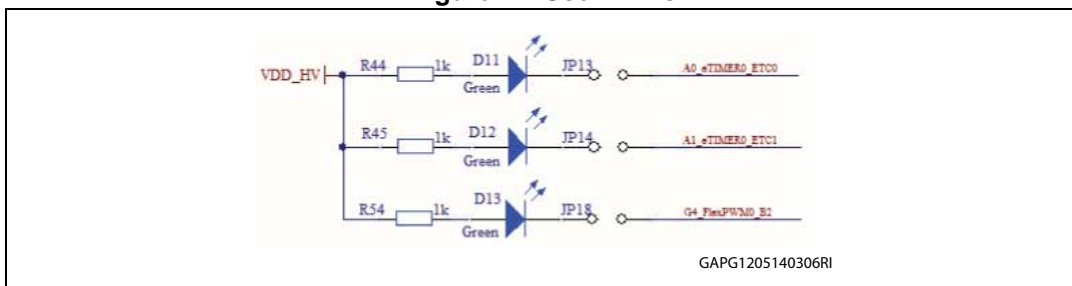

Table 2. User LEDs

Item	Color	µC Pin - function
D11	Green	A0_eTIMER0_ETC0
D12	Green	A1_eTIMER0_ETC1
D13	Green	G4_FlexPWM0_B2

2.5 ADC reference

Jumper JP 12 allows setting the ADC reference level: 5 V or 3.3 V.

Figure 12. ADC reference

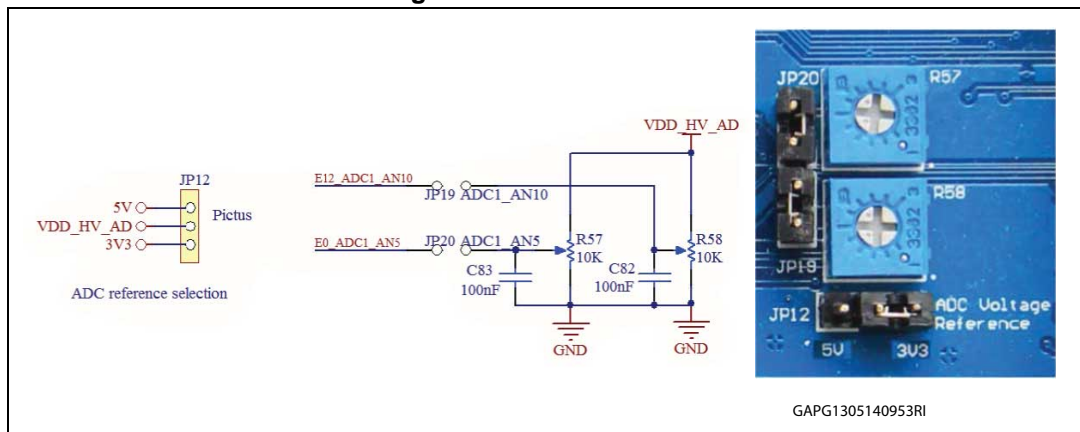

Two potentiometers (R56 and R57) and the jumpers JP19 and JP20 allow the user to quickly evaluate the performance of ADC: the analog voltage can be adjusted in the range is $0 \div VDD_HV_ADC$.

Removing the jumper the pin E0 and E12 can be used to support a different application.

2.6 Integrated USB programmer/debugger

The integrated debugger, based on the device FTDI2232H and UDE PLS software, allows the user to build, run and debug the software applications.

The integrated debugger can be configured to operate as standalone unit and used to program and debug another SPC5xx application or an evaluation boards. The board is configured to operate using the integrated debugger.

The SPC560P-DISP discovery board includes a full-featured, perpetual code-limited (128 Kbytes) PLS software license. The debugger serial number is reported on a label applied on the board.

To download the debugger software and to activate license go to the PLS website.

The integrated debugger is accessible via ST's free integrated development environment, SPC5Studio (www.st.com/spc5studio).

Figure 13. Integrated debugger – USB input

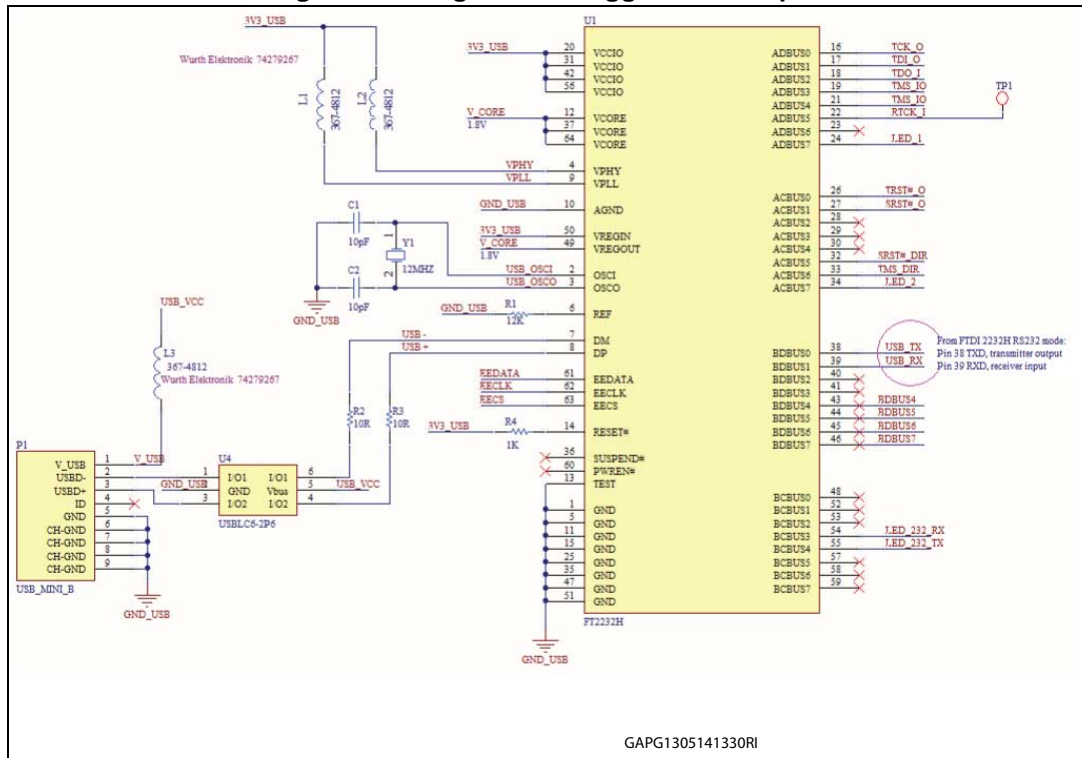

Figure 14. Integrated debugger – EEPROM

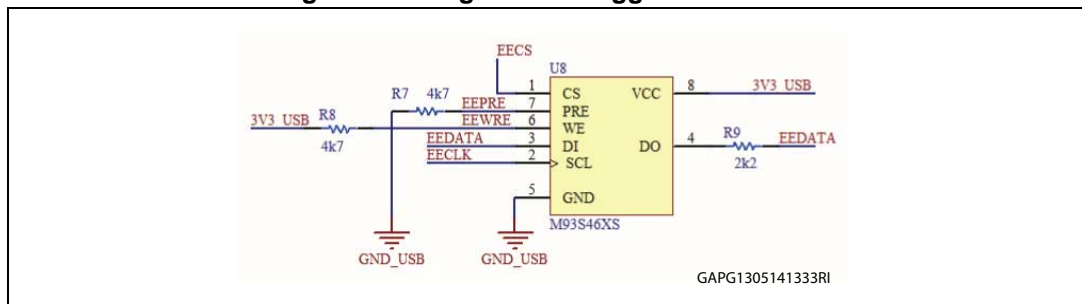

Figure 15. Integrated debugger - Level Shifters

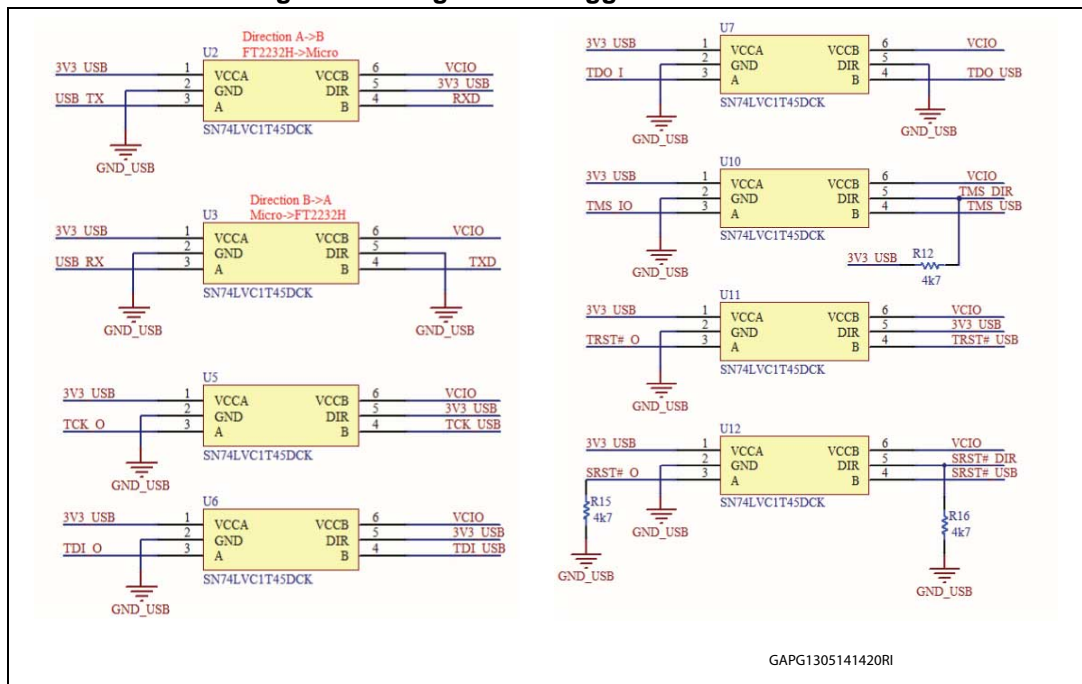
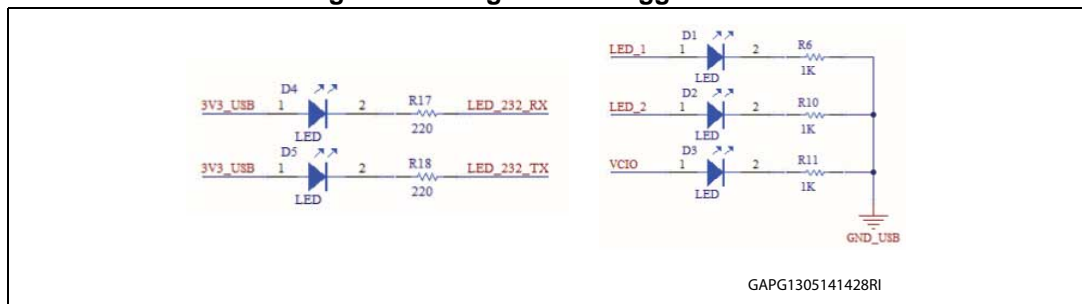

Figure 16. Integrated debugger - LEDs



2.7 JTAG connectors

The integrated debugger can also be used as standalone debugger. To make possible this functionality, two HW options are possible:

1. Remove the debugger for the main board cutting small portions of PCB where is located the debugger; (cuttable PCB).
2. Let the integrated PLS adapter on the board and electrically disconnect the adapter to the microcontroller

The first option consists to remove the portion of PCB where is assembled the debugger cutting small portion of PCB. Both the debugger and the discovery board do not need HW modification to work properly^(b). A JTAG connector (X1) present in the detached debugger/programmer allows connecting the board to a target application. Level shifters are

b. Removing the integrated adapter the discovery board must be supplied using a PSU

present to equalize the I/O levels. The discovery board can be programmed using an external programmer connected to the JTAG X2.

The second solution does not need to remove the debugger because it can be disconnected electrically removing the array resistor RP1. The two JTAG connectors allow connecting the programmer to the target application. The discovery board must be supplied using a PSU and a programmer must be connected to the JTAG port to program the microcontroller.

Figure 17. JTAG connectors

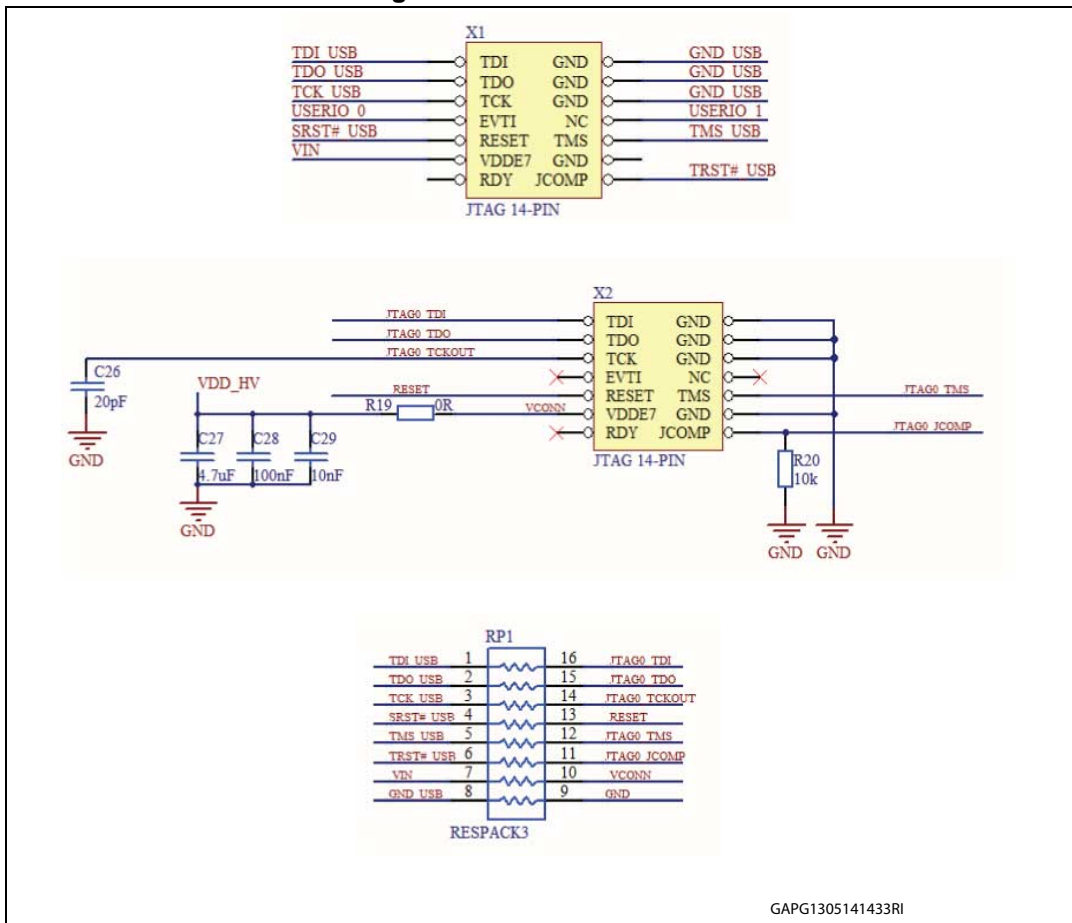

GAPG1305141433RI

Table 3. JTAG connector (X1 and X2)

Pin	Signal	Pin	Signal
1	TDI	2	GND
3	TDO	4	GND
5	TCK	6	GND
7	EVTI	8	NC
9	RESET	10	TMS
11	VDDE7	12	GND
13	RDY	14	JCOMP

2.8 FlexCAN interface and Safety Port

SPC560P50L5 includes a FlexCAN interface controller (version 2.0B), the transceiver and a connector.

The controller also includes a second CAN controller synthesized to run at high bit rates to be used as a safety port. It can be used as a second independent CAN module.

JP22 and JP23 allow selecting the CAN channel connected to the transceiver; see [Figure 18](#). JP10 connects the 120 Ω termination resistor (the resistor is connected when the jumper is present).

Figure 18. FlexCAN - jumpers configuration



The CAN output signals are available in a single 2x8 pin male connector (see U24 in [Figure 19](#)); the FlexCAN output signals are connected to the even pins of the connector.

Figure 19. High Speed CAN and FlexRay

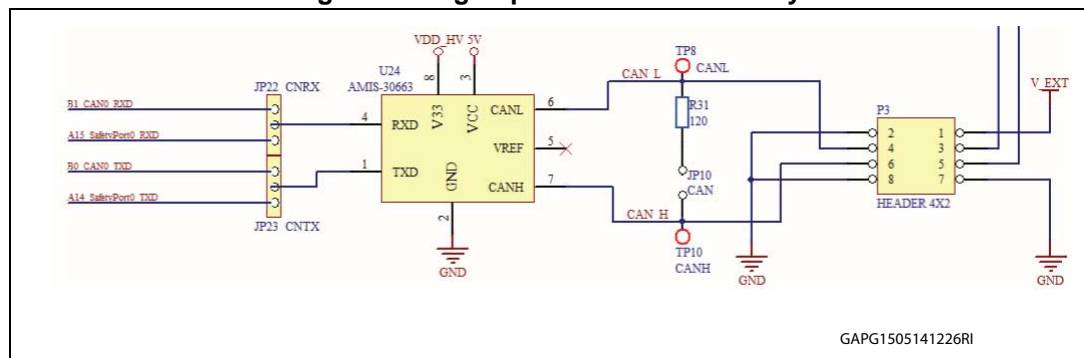

2.9 FlexRay interface

The FlexRay module implements the Protocol Specification 2.1 with selectable single or dual channel support. The transceiver used is TJA1080 (U15); JP7, JP8 and JP9 allow configuring the FlexRay signals connected to the transceiver. The output signals are located in the same connector used for the FlexCAN, the odd pins are used.

Figure 20. FlexRay – jumper configuration



Figure 21. FlexRay transceiver and connector

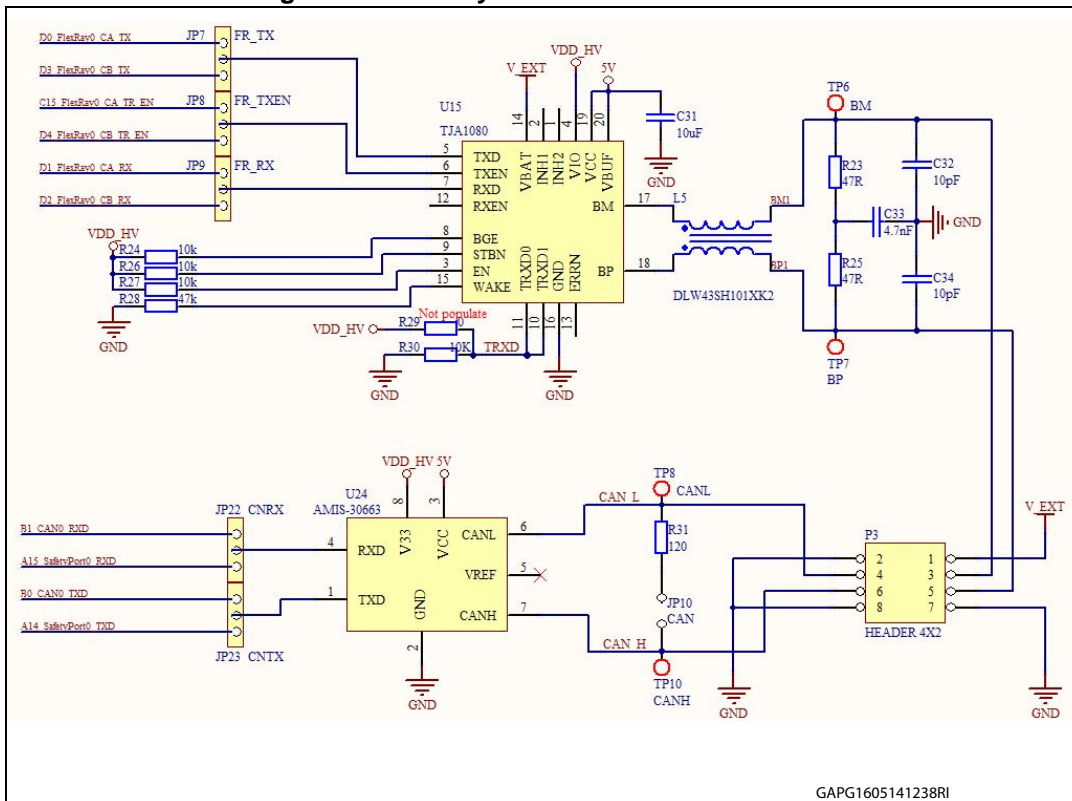

2.10 LINFlex communication (Serial Communication Interface module)

The LINFlex supports LIN Master mode, LIN Slave mode and UART mode. LIN state machine is compliant to LIN1.3, 2.0, and 2.1 specifications.

Figure 22 and Figure 23 show the hardware implemented for the UART/LIN: U18 and U14 are the LIN and the K-Line transceivers respectively.

JP4 and JP5 configure UART or LIN; the RX and SX signals are available on the connector JP6.

Figure 22. LINFlex communication (I)

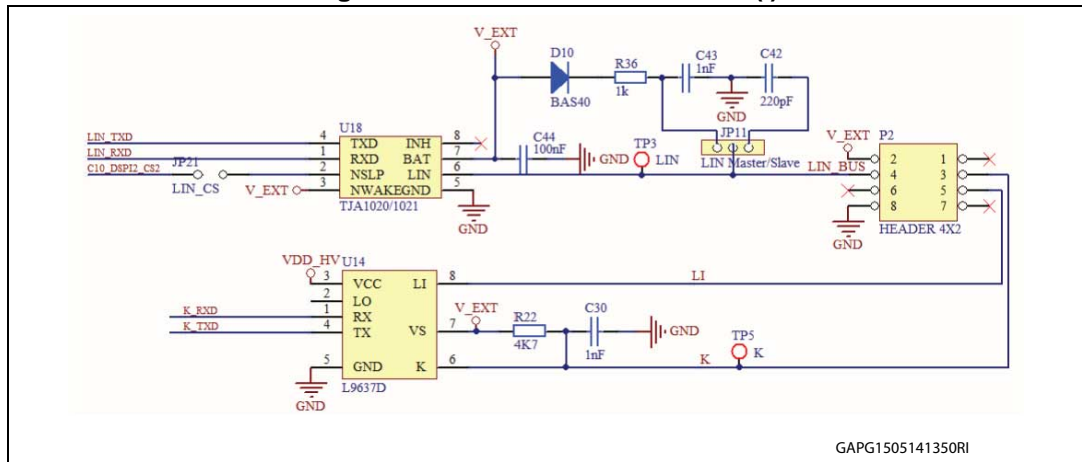

GAPG1505141350RI

Figure 23. LINFlex communication (II)

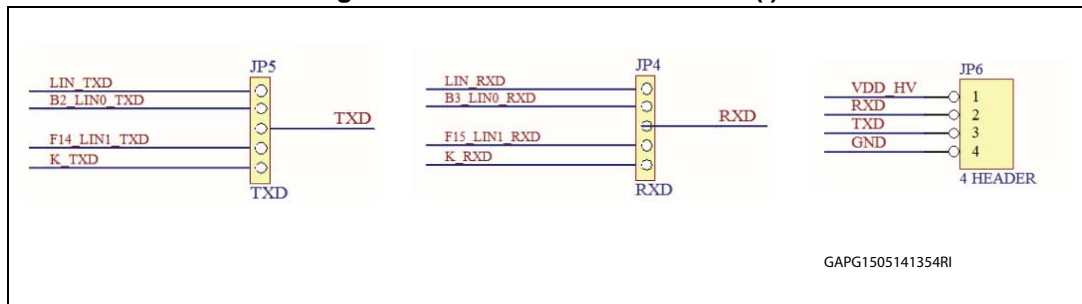

GAPG1505141354RI

2.11 Connectors Arduino-compatible

In this discovery board are present Arduino compatible: the connectors J1 J2, J4 and J5 are compatible with the Arduino-UNO shields and the J5, J6, and JP2 are compatible with Arduino-Mega shields.

The figures here below are showing the connections of the microcontroller pins and the Arduino connectors.

Figure 24. Connectors Arduino-compatible (I)

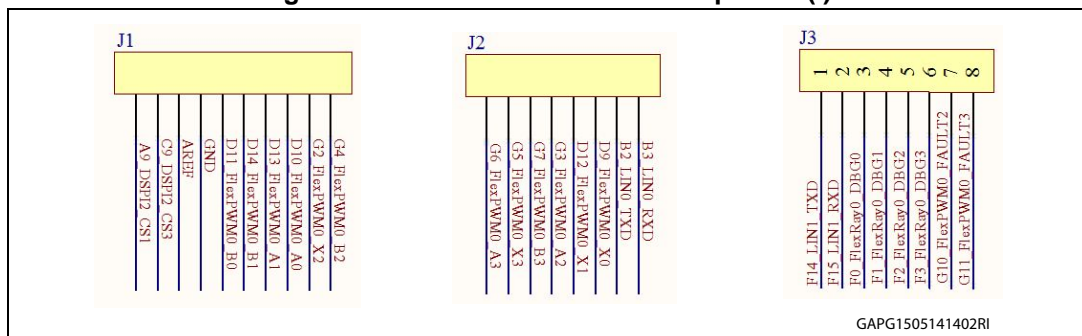

GAPG1505141402RI

Figure 25. Connectors Arduino-compatible (II)

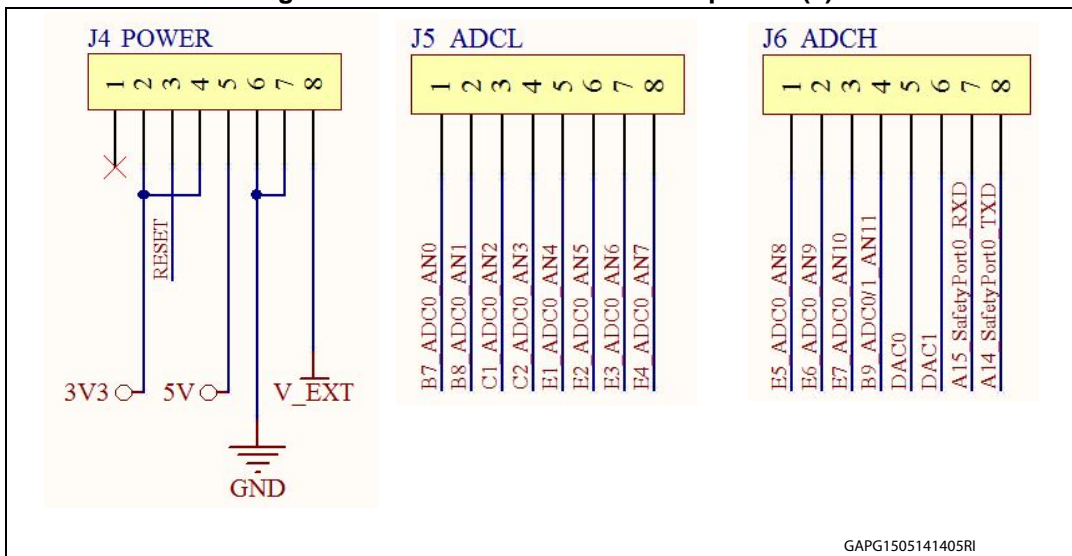

Figure 26. Connectors Arduino-compatible (III)

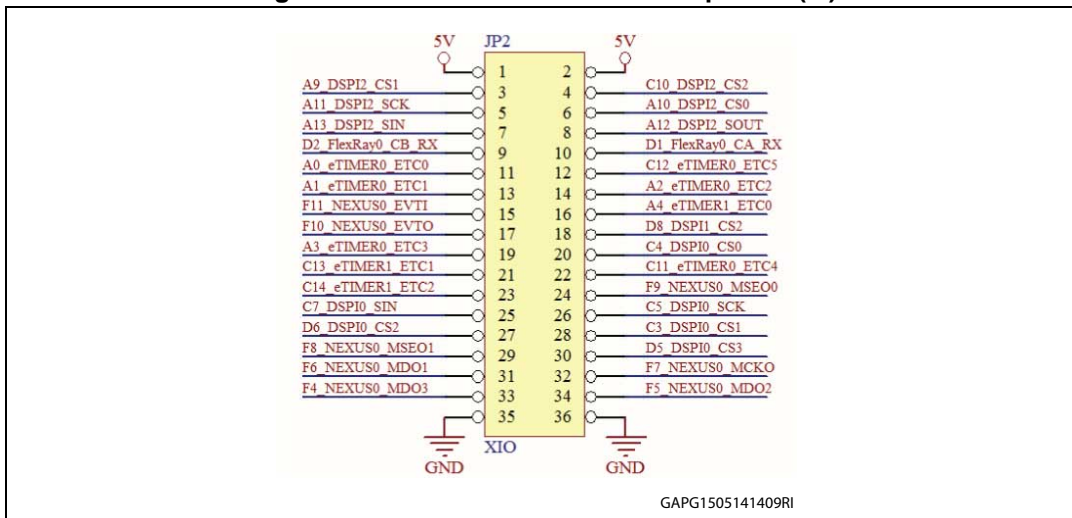
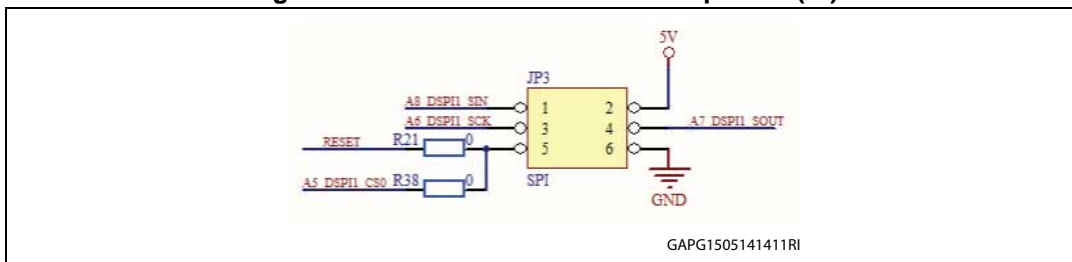

Figure 27. Connectors Arduino-compatible (IV)



2.12 I/O header

All of the MCU GPIOs and communication channels can be accessed through a 4x37 I/O headers. Here below the I/O header pin mapping summarized in .

Figure 28. I/O header (Schematic diagram)

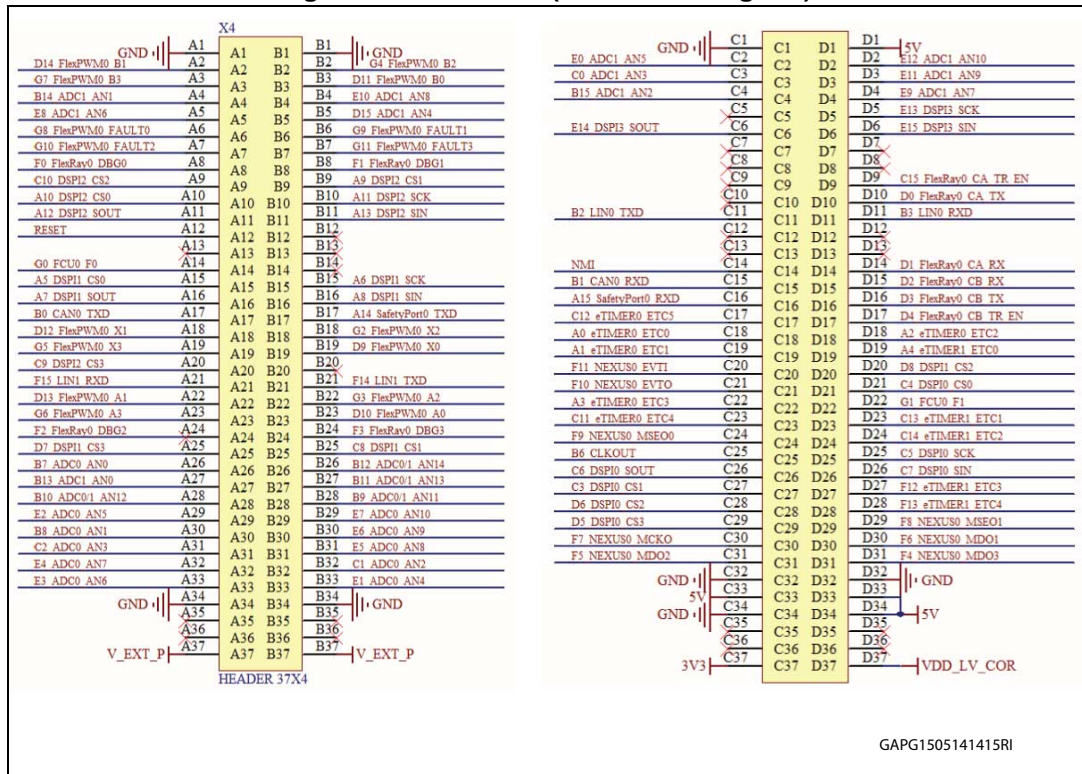

Table 4. I/O header (Schematic diagram)

Pin number	A	B	C	D
1	GND	GND	GND	+5V
2	D14_FlexPWM0_B1	G4_FlexPWM0_B2	E0_ADC1_AN5	E12_ADC1_AN10
3	G7_FlexPWM0_B3	D11_FlexPWM0_B0	C0_ADC1_AN3	E11_ADC1_AN9
4	B14_ADC1_AN1	E10_ADC1_AN8	B15_ADC1_AN2	E9_ADC1_AN7
5	E8_ADC1_AN6	D15_ADC1_AN4	--	E13_DSPI3_SCK
6	G8_FlexPWM0_FAU LT0	G9_FlexPWM0_FAU LT1	E14_DSPI3_SOU T	E15_DSPI3_SIN
7	G10_FlexPWM0_FA ULT2	G11_FlexPWM0_FA ULT3	--	--
8	F0_FlexRay0_DBG0	F1_FlexRay0_DBG1	--	--
9	C10_DSPI2_CS2	A9_DSPI2_CS1	--	C15_FlexRay0_CA_T R_EN
10	A10_DSPI2_CS0	A11_DSPI2_SCK	--	D0_FlexRay0_CA_TX
11	A12_DSPI2_SOUT	A13_DSPI2_SIN	B2_LIN0_TXD	B3_LIN0_RXD
12	RESET	--	--	--
13	--	--	--	--
14	G0_FCU0_F0	--	NMI	D1_FlexRay0_CA_RX

Table 4. I/O header (Schematic diagram) (continued)

Pin number	A	B	C	D
15	A5_DSPI1_CS0	A6_DSPI1_SCK	B1_CAN0_RXD	D2_FlexRay0_CB_RX
16	A7_DSPI1_SOUT	A8_DSPI1_SIN	A15_SafetyPort0_RXD	D3_FlexRay0_CB_TX
17	B0_CAN0_TXD	A14_SafetyPort0_TXD	C12_eTIMER0_ETC5	D4_FlexRay0_CB_TR_EN
18	D12_FlexPWM0_X1	G2_FlexPWM0_X2	A0_eTIMER0_ETC0	A2_eTIMER0_ETC2
19	G5_FlexPWM0_X3	D9_FlexPWM0_X0	A1_eTIMER0_ETC1	A4_eTIMER1_ETC0
20	C9_DSPI2_CS3	--	F11_NEXUS0_EV TI	D8_DSPI1_CS2
21	F15_LIN1_RXD	F14_LIN1_TXD	F10_NEXUS0_EV TO	C4_DSPIO_CS0
22	D13_FlexPWM0_A1	G3_FlexPWM0_A2	A3_eTIMER0_ETC3	G1_FCU0_F1
23	G6_FlexPWM0_A3	D10_FlexPWM0_A0	C11_eTIMER0_ETC4	C13_eTIMER1_ETC1
24	F2_FlexRay0_DBG2	F3_FlexRay0_DBG3	F9_NEXUS0_MSE00	C14_eTIMER1_ETC2
25	D7_DSPI1_CS3	C8_DSPI1_CS1	B6_CLKOUT	C5_DSPIO_SCK
26	B7_ADC0_AN0	B12_ADC0/1_AN14	C6_DSPIO_SOUT	C7_DSPIO_SIN
27	B13_ADC1_AN0	B11_ADC0/1_AN13	C3_DSPIO_CS1	F12_eTIMER1_ETC3
28	B10_ADC0/1_AN12	B9_ADC0/1_AN11	D6_DSPIO_CS2	F13_eTIMER1_ETC4
29	E2_ADC0_AN5	E7_ADC0_AN10	D5_DSPIO_CS3	F8_NEXUS0_MSE01
30	B8_ADC0_AN1	E6_ADC0_AN9	F7_NEXUS0_MCKO	F6_NEXUS0_MDO1
31	C2_ADC0_AN3	E5_ADC0_AN8	F5_NEXUS0_MDO2	F4_NEXUS0_MDO3
32	E4_ADC0_AN7	C1_ADC0_AN2	GND	GND
33	E3_ADC0_AN6	E1_ADC0_AN4	+5V	5V
34	GND	GND	GND	5V
35	--	--	--	--
36	--	--	--	--
37	V_EXT_P	V_EXT_P	3v3	VDD_LV_COR

3 PCB layout

Figure 29. PCB layout

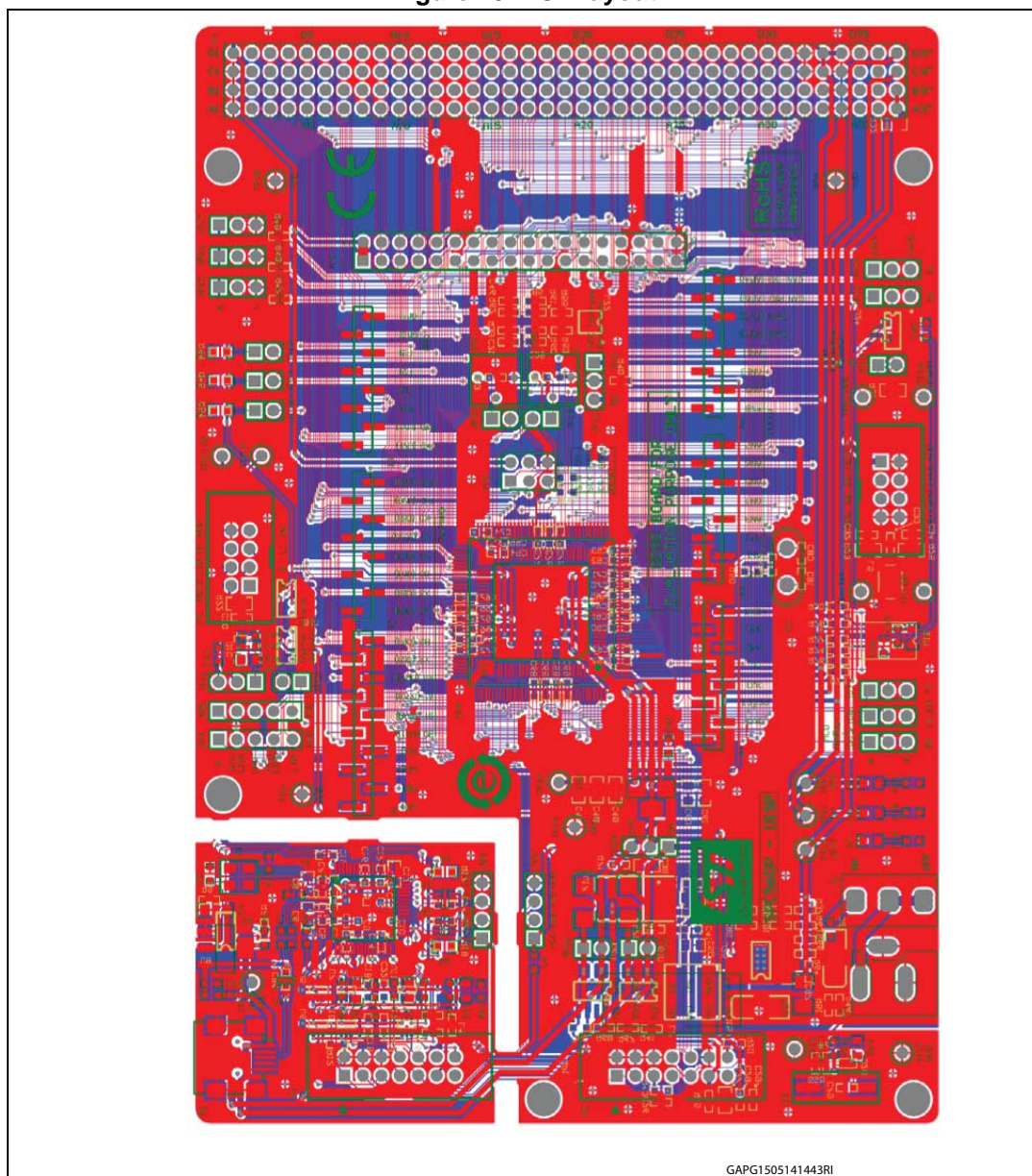

GAPG1505141443RI

Appendix A General handling precautions

The following precautions are recommended when using the SPC560P-DISP:

- Do not modify or manipulate the board when the USB or DC supply is connected to the board.
- Do not supply the board with a DC source higher than +12V.
- Any equipment or tool used for any manipulation of the semiconductor devices or board modification should be shielded and connected to ground.
- The connectors and cables should be plugged and removed when the board is off.
- It is suggested recommended to use antistatic tools.

Revision history

Table 5. Document revision history

Date	Revision	Changes
20-May-2014	1	Initial release.

Please Read Carefully:

Information in this document is provided solely in connection with ST products. STMicroelectronics NV and its subsidiaries ("ST") reserve the right to make changes, corrections, modifications or improvements, to this document, and the products and services described herein at any time, without notice.

All ST products are sold pursuant to ST's terms and conditions of sale.

Purchasers are solely responsible for the choice, selection and use of the ST products and services described herein, and ST assumes no liability whatsoever relating to the choice, selection or use of the ST products and services described herein.

No license, express or implied, by estoppel or otherwise, to any intellectual property rights is granted under this document. If any part of this document refers to any third party products or services it shall not be deemed a license grant by ST for the use of such third party products or services, or any intellectual property contained therein or considered as a warranty covering the use in any manner whatsoever of such third party products or services or any intellectual property contained therein.

UNLESS OTHERWISE SET FORTH IN ST'S TERMS AND CONDITIONS OF SALE ST DISCLAIMS ANY EXPRESS OR IMPLIED WARRANTY WITH RESPECT TO THE USE AND/OR SALE OF ST PRODUCTS INCLUDING WITHOUT LIMITATION IMPLIED WARRANTIES OF MERCHANTABILITY, FITNESS FOR A PARTICULAR PURPOSE (AND THEIR EQUIVALENTS UNDER THE LAWS OF ANY JURISDICTION), OR INFRINGEMENT OF ANY PATENT, COPYRIGHT OR OTHER INTELLECTUAL PROPERTY RIGHT.

ST PRODUCTS ARE NOT DESIGNED OR AUTHORIZED FOR USE IN: (A) SAFETY CRITICAL APPLICATIONS SUCH AS LIFE SUPPORTING, ACTIVE IMPLANTED DEVICES OR SYSTEMS WITH PRODUCT FUNCTIONAL SAFETY REQUIREMENTS; (B) AERONAUTIC APPLICATIONS; (C) AUTOMOTIVE APPLICATIONS OR ENVIRONMENTS, AND/OR (D) AEROSPACE APPLICATIONS OR ENVIRONMENTS. WHERE ST PRODUCTS ARE NOT DESIGNED FOR SUCH USE, THE PURCHASER SHALL USE PRODUCTS AT PURCHASER'S SOLE RISK, EVEN IF ST HAS BEEN INFORMED IN WRITING OF SUCH USAGE, UNLESS A PRODUCT IS EXPRESSLY DESIGNATED BY ST AS BEING INTENDED FOR "AUTOMOTIVE, AUTOMOTIVE SAFETY OR MEDICAL" INDUSTRY DOMAINS ACCORDING TO ST PRODUCT DESIGN SPECIFICATIONS. PRODUCTS FORMALLY ESCC, QML OR JAN QUALIFIED ARE DEEMED SUITABLE FOR USE IN AEROSPACE BY THE CORRESPONDING GOVERNMENTAL AGENCY.

Resale of ST products with provisions different from the statements and/or technical features set forth in this document shall immediately void any warranty granted by ST for the ST product or service described herein and shall not create or extend in any manner whatsoever, any liability of ST.

ST and the ST logo are trademarks or registered trademarks of ST in various countries.

Information in this document supersedes and replaces all information previously supplied.

The ST logo is a registered trademark of STMicroelectronics. All other names are the property of their respective owners.

© 2014 STMicroelectronics - All rights reserved

STMicroelectronics group of companies

Australia - Belgium - Brazil - Canada - China - Czech Republic - Finland - France - Germany - Hong Kong - India - Israel - Italy - Japan - Malaysia - Malta - Morocco - Philippines - Singapore - Spain - Sweden - Switzerland - United Kingdom - United States of America

www.st.com