

TPS6612x Integrated Sink with VBUS LDO Regulator

1 Features

- Integrated 22 m Ω (typical), 32-V tolerant NFET 4-V to 22-V sink path, up to 5 A
- Built-in soft-start to limit in-rush currents
- Integrated high voltage VBUS LDO regulator (3.3-V or 5.0-V per device type)
- Optional VBUS overvoltage protection via pin configuration.
- System supply and VBUS undervoltage protection
- Overtemperature protection
- Reverse-current protection
- Fault pin with de-glitched fault reporting
- Small footprint WCSP packaging, no HDI required.

2 Applications

- [Desktop PC/motherboard](#)
- [Standard notebook PC](#)
- [Chromebook and WOA](#)
- [Docking station](#)
- [Port/cable adapters and dongles](#)

3 Description

The TPS6612x contains an integrated 4-V to 22-V Sink power path. The power path supports overtemperature and reverse current protection. VBUS has overvoltage protection with its level being set by an optional external resistor divider. If no overvoltage protection is desired, it may be disabled by grounding the OVP terminal. The TPS6612x supports a fault pin that indicates overtemperature events.

The TPS6612x series also supports a high voltage VBUS LDO regulator (3.3-V or 5-V per device type) useful for supplying power to the device and other system components when operating in dead battery conditions. The TPS66120 regulates to 3.3 V and the TPS66121 regulates to 5 V.

Device Information⁽¹⁾

PART NUMBER	PACKAGE	BODY SIZE (NOM)
TPS66120	WCSP (28)	1.606 mm x 2.806 mm
TPS66121		

(1) For all available packages, see the orderable addendum at the end of the data sheet.

Function Table

EN0	Device State
0	Sink path disabled
1	Sink path enabled

TPS6612x Block Diagram

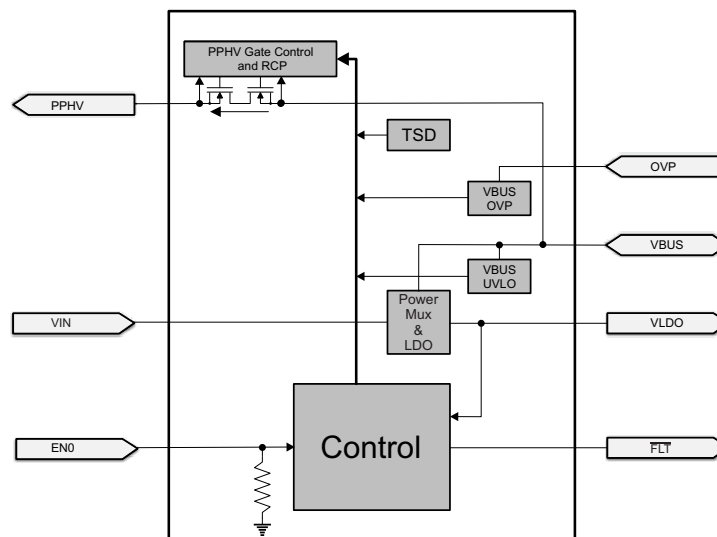

Table of Contents

1 Features	1	7.1 Overview	10
2 Applications	1	7.2 Functional Block Diagram	10
3 Description	1	7.3 Feature Description	10
4 Revision History	2	7.4 Device Functional Modes	17
5 Pin Configuration and Functions	3	8 Application and Implementation	20
6 Specifications	4	8.1 Application Information	20
6.1 Absolute Maximum Ratings	4	8.2 Typical Application	20
6.2 ESD Ratings	4	9 Power Supply Recommendations	23
6.3 Recommended Operating Conditions	4	10 Layout	24
6.4 Recommended Supply Load Capacitance	5	10.1 Layout Guidelines	24
6.5 Thermal Information	5	10.2 Layout Example	24
6.6 PPHV Power Switch Characteristics	5	11 Device and Documentation Support	25
6.7 Power Path Supervisory	6	11.1 Related Links	25
6.8 VBUS LDO Characteristics	6	11.2 Receiving Notification of Documentation Updates	25
6.9 Thermal Shutdown Characteristics	7	11.3 Support Resources	25
6.10 Input-output (I/O) Characteristics	7	11.4 Trademarks	25
6.11 Power Consumption Characteristics	8	11.5 Electrostatic Discharge Caution	25
6.12 Typical Characteristics	9	11.6 Glossary	25
7 Detailed Description	10	12 Mechanical, Packaging, and Orderable Information	25

4 Revision History

Changes from Revision A (September 2019) to Revision B	Page
• Changed from Advance Information to Production Data	1

Changes from Original (August 2019) to Revision A	Page
• Updated Applications section with links	1
• Added Typical Characteristics section	9
• Added Application Curves section	22

5 Pin Configuration and Functions

TPS6612x YBG Package
28-Pin WCSP
Top View

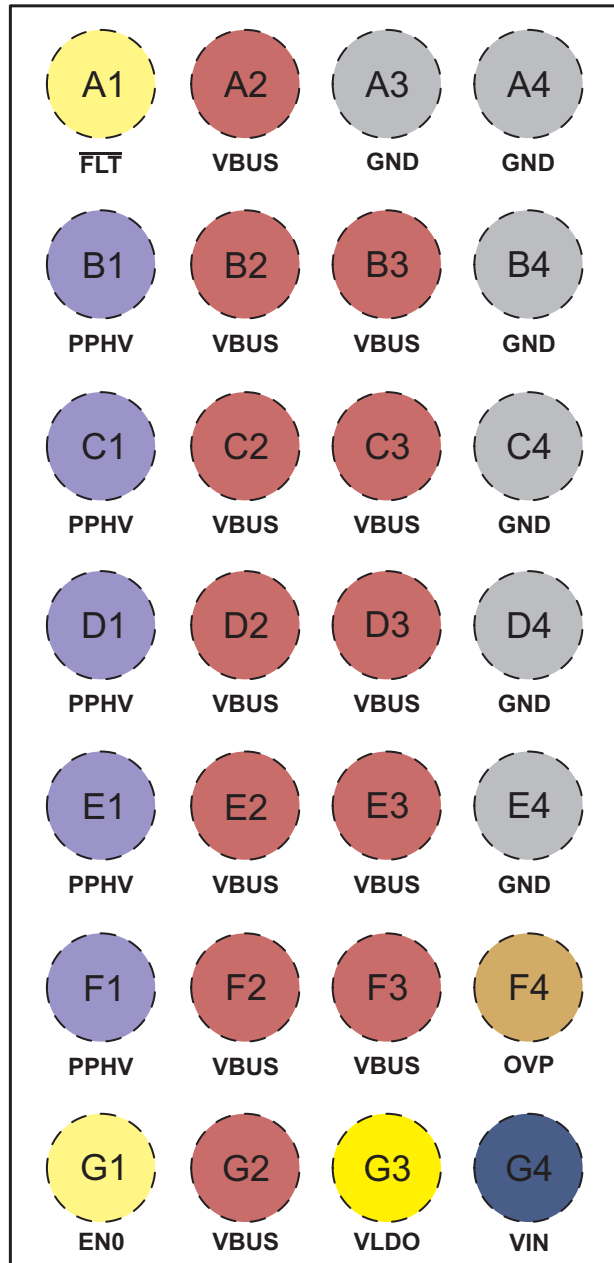

Pin Functions

Pin		I/O	Reset State	Description
Name	No.			
PPHV	B1, C1, D1, E1, F1	Power	Off	HV System Supply from VBUS. Bypass with capacitance CPPHV to GND.
VBUS	A2, B2, B3, C2, C3, D2, D3, E2, E3, F2, F3, G2	Power	-	4V to 20V nominal input supply to PPHV. Bypass with capacitance CVBUS to GND.

Pin Functions (continued)

Pin		I/O	Reset State	Description
Name	No.			
VIN	G4	Power	-	Device input supply. Bypass with capacitance CVIN to GND.
VLDO	G3	Power	-	VIN supply or VBUS LDO regulated supply output from power multiplexer. Bypass with capacitance CVLDO to GND.
GND	A3, A4, B4, C4, D4, E4	Ground	-	Ground. Connect all pins to ground plane.
OVP	F4	Analog	-	Selects VBUS OVP. Tie pin to VBUS resistor divider output to set desired VBUS OVP level. Tie pin to GND to remove VBUS OVP function.
EN0	G1	Digital Input	Pull-down	Enable PPHV sink path. Internal pull-down.
$\overline{\text{FLT}}$	A1	Digital Output	Hi-Z	Fault Output Indicator. Active low. This pin is a true open-drain (no PMOS). Float pin when unused.

6 Specifications

6.1 Absolute Maximum Ratings

over operating free-air temperature range (unless otherwise noted)⁽¹⁾

PARAMETER		MIN	MAX	UNIT
Terminal voltage range ⁽²⁾	EN0 ⁽³⁾ , $\overline{\text{FLT}}$, VIN, VLDO	-0.3	6.2	V
Terminal voltage range ⁽²⁾	OVP	-0.3	VBUS	V
Terminal voltage range ⁽²⁾	VBUS, power path disabled (stand off voltage)	-0.5	32	V
Terminal voltage range ⁽²⁾	VBUS, power path enabled ⁽⁴⁾	-0.5	26	V
Terminal voltage range ⁽²⁾	PPHV	-0.3	26	V
Terminal positive source current	VLDO sourced from VBUS VLDO	Internally limited		mA
	VLDO sourced from VIN			50
Storage temperature		-55	150	°C

- (1) Stresses beyond those listed under *Absolute Maximum Ratings* may cause permanent damage to the device. These are stress ratings only, which do not imply functional operation of the device at these or any other conditions beyond those indicated under *Recommended Operating Conditions*. Exposure to absolute-maximum-rated conditions for extended periods may affect device reliability.
- (2) All voltage values are with respect to network GND. All GND pins must be connected directly to the GND plane of the board.
- (3) EN0 has an internal voltage clamp and may be driven above the absolute maximum voltage rating up to EN_CLAMP maximum specification if current is limited to less than 100 μ A.
- (4) For VBUS, a TVS protection with a break down voltage falling between the Recommended and Absolute maximum ratings is recommended, such as the TVS2200.

6.2 ESD Ratings

			VALUE	UNIT
V _(ESD)	Electrostatic discharge	Human-body model (HBM), per ANSI/ESDA/JEDEC JS-001 ⁽¹⁾	±1000	V
		Charged-device model (CDM), per JEDEC specification JESD22-C101 ⁽²⁾	±500	

- (1) JEDEC document JEP155 states that 500-V HBM allows safe manufacturing with a standard ESD control process.
- (2) JEDEC document JEP157 states that 250-V CDM allows safe manufacturing with a standard ESD control process.

6.3 Recommended Operating Conditions

over operating free-air temperature range (unless otherwise noted)⁽¹⁾

			MIN	MAX	UNIT
V _{VIN}	Input voltage range ⁽¹⁾	VIN, TPS66120 only.	2.85	3.6	V
		VIN, TPS66121 only.	4.5	5.5	V
V _{PPHV}	Output voltage range ⁽¹⁾	PPHV	0	22	V
V _{VBUS}	Input voltage range ⁽¹⁾	VBUS when sinking	4	22	V
V _{EN}	Input voltage range ⁽¹⁾	EN0	0	5.5	V
V _{$\overline{\text{FLT}}$}	Output voltage range ⁽¹⁾	$\overline{\text{FLT}}$	0	5.5	V

- (1) All voltage values are with respect to network GND. All GND pins must be connected directly to the ground plane of the board.

Recommended Operating Conditions (continued)

over operating free-air temperature range (unless otherwise noted)⁽¹⁾

			MIN	MAX	UNIT
I _{O_PPHV}	Continuous current from VBUS to PPHV	T _J = 105°C		4	A
		T _J = 100°C		5	A
I _{O_VLDO}	Output current from VBUS LDO			30	mA
R _{IREF}	External resistor current limit reference	75kΩ ±1% overall tolerance	74.25	75.75	kΩ
T _J	Operating junction temperature		-10	125	°C
RR_PPHV	Maximum ramp rate on PPHV input supply		-2	2	V/μs
RR_VBUS	Maximum ramp rate on VBUS input supply		-2	2	V/μs
RR_VIN	Maximum ramp rate on VIN input supply			30	mV/μs

6.4 Recommended Supply Load Capacitance

over operating free-air temperature range (unless otherwise noted)

PARAMETER ⁽¹⁾		MIN	TYP	MAX	UNIT
CVIN	Capacitance on VIN	1			μF
CVLDO	Capacitance on VLDO	2.5	4.7	10	μF
CVBUS	Capacitance on VBUS	1		10	μF
CPPHV	Capacitance present on PPHV ⁽²⁾	1	47	100	μF

- Capacitance values do not include any derating factors. For example, if 5.0 μF is required and the external capacitor value reduces by 50% at the required operating voltage, then the required external capacitor value would be 10 μF.
- This capacitance represents the system side load capacitance that may be seen by the device e.g. from a typical battery charging system. Discrete capacitance is not required for proper operation.

6.5 Thermal Information

THERMAL METRIC ⁽¹⁾		TPS6612x	UNIT
		YBG (WCSP)	
		28 PINS	
R _{θJA,EFF}	Effective Junction-to-ambient thermal resistance ⁽²⁾	44.3	°C/W
R _{θJA}	Junction-to-ambient thermal resistance	62.7	°C/W
R _{θJC(top)}	Junction-to-case (top) thermal resistance	0.4	°C/W
R _{θJB}	Junction-to-board thermal resistance	13.8	°C/W
ψ _{JT}	Junction-to-top characterization parameter	0.2	°C/W
ψ _{JB}	Junction-to-board characterization parameter	13.7	°C/W
ψ _{JB,EFF}	Effective Junction-to-board characterization parameter ⁽²⁾	14.5	°C/W

- For more information about traditional and new thermal metrics, see the [Semiconductor and IC Package Thermal Metrics](#) application report.
- Models based on typical application layout.

6.6 PPHV Power Switch Characteristics

Operating under these conditions unless otherwise noted: -10 °C ≤ T_J ≤ 125 °C, 2.85V ≤ V_{VIN} ≤ 5.5V

PARAMETER		TEST CONDITIONS	MIN	TYP	MAX	UNIT
R _{PPHV}	Resistance from PPHV to VBUS	I _{LOAD} = 1 A, T _J = 25 °C, SNK state.		22	26	mΩ
		I _{LOAD} = 1 A, -10 °C ≤ T _J ≤ 125 °C, SNK state.		22	45	mΩ
V _{PPHV_RCP}	Maximum voltage due to reverse current during RCP response.	SNK state, V _{VBUS} = 5.5V, ramp V _{PPHV} from 5.5V to 21V at 100 V/ms, C _{VBUS} = 10μF, measure V _{VBUS}			5.8	V
V _{PPHV_OVP}	Maximum voltage rise due to reverse current during VBUS OVP response.	SNK state, V _{VBUS} = 5.5V, set V _{OVP} = 6V, ramp V _{VBUS} from 5.5V to 21V at 100 V/ms, C _{PPHV} = 4.7μF, measure V _{PPHV}			6.2	V

PPHV Power Switch Characteristics (continued)

 Operating under these conditions unless otherwise noted: $-10\text{ }^{\circ}\text{C} \leq T_J \leq 125\text{ }^{\circ}\text{C}$, $2.85\text{V} \leq V_{VIN} \leq 5.5\text{V}$

PARAMETER		TEST CONDITIONS	MIN	TYP	MAX	UNIT
$V_{RCP_THRES_PPHV}$	Reverse current blocking voltage threshold for PPHV switch		2	6	10	mV
SS	Soft-start slew rate	Transition from DISABLED state to SNK state, $V_{VBUS} = 5\text{V}$, $C_{PPHV} = 100\mu\text{F}$. Measure slew rate on PPHV.	0.2		0.6	V/ms
t_{ON_PPHV}	PPHV enable time including Soft-start.	$R_{PPHV} = 100\Omega$, $V_{VBUS} = 5\text{V}$, $C_{PPHV} = 100\mu\text{F}$. Transition from DISABLED state to SNK state, V_{PPHV} at 90% of final value.	9	15	29	ms
t_{OFF_PPHV}	PPHV disable time.	$R_{PPHV} = 100\Omega$, $V_{VBUS} = 5\text{V}$, $C_{PPHV} = 4.7\mu\text{F}$. Transition from SNK state to DISABLED state, V_{PPHV} falls to 4.5V.	0.9	2.2	4.3	ms

6.7 Power Path Supervisory

 Operating under these conditions unless otherwise noted: $-10\text{ }^{\circ}\text{C} \leq T_J \leq 125\text{ }^{\circ}\text{C}$, $2.85\text{V} \leq V_{VIN} \leq 5.5\text{V}$, $R_{IREF} = 75\text{ k}\Omega \pm 1\%$ overall tolerance

PARAMETER		TEST CONDITIONS	MIN	TYP	MAX	UNIT
UV_VIN_R	Undervoltage threshold for VIN. VBUS LDO disables when threshold reached.	VIN rising, TPS66120 only.	2.45		2.75	V
		VIN rising, TPS66121 only.	3.89		4.40	V
UV_VIN_F	Undervoltage threshold for VIN. Device resets.	VIN falling, TPS66120 only.	2.35		2.65	V
		VIN falling, TPS66121 only.	3.79		4.30	V
UVH_VIN	Undervoltage hysteresis for VIN.		100		mV	
UV_VBUS_R	Undervoltage threshold for VBUS. PPHV switch disabled until threshold reached.	VBUS rising	3.35		3.75	V
UV_VBUS_F	Undervoltage threshold for VBUS. PPHV switch disables when threshold reached.	VBUS falling	3.15		3.55	V
UVH_VBUS	Undervoltage hysteresis for VBUS			200		mV
OVP_REF	OVP reference voltage.		0.93	1	1.07	V
VFWD_DROP_VIN	Forward voltage drop across VIN to VLDO switch	$I_{VLDO} = 35\text{ mA}$			90	mV
t_{VIN_STABLE}	When VIN is above UV_VIN_R for this duration, VIN is considered valid. If device is being powered by VBUS LDO, it will then switch to VIN supply and VBUS LDO will be disabled.		5		15	ms

6.8 VBUS LDO Characteristics

 Operating under these conditions unless otherwise noted: $-10\text{ }^{\circ}\text{C} \leq T_J \leq 125\text{ }^{\circ}\text{C}$, $2.85\text{V} \leq V_{VIN} \leq 5.5\text{V}$, $R_{IREF} = 75\text{ k}\Omega \pm 1\%$ overall tolerance

PARAMETER		TEST CONDITIONS	MIN	TYP	MAX	UNIT
$V_{VBUS_LDO_3V}$	Output voltage of VBUS LDO	For TPS66120: $V_{IN} = 0\text{V}$, $V_{BUS} \geq 3.8\text{V}$, $0 \leq I_{VBUS_LDO} \leq 30\text{mA}$	3.07	3.3	3.53	V
$V_{VBUS_LDO_5V}$	Output voltage of VBUS LDO	For TPS66121: $V_{IN} = 0\text{V}$, $V_{BUS} \geq 5.5\text{V}$, $0 \leq I_{VBUS_LDO} \leq 30\text{mA}$	4.65	5.0	5.35	V
VDO_VBUS_LDO_3V	Drop out voltage of VDD LDO	For TPS66120: $V_{IN} = 0\text{V}$, $V_{BUS} = 3.135\text{V}$, $I_{VBUS_LDO} = 30\text{ mA}$			0.5	V
VDO_VBUS_LDO_5V	Drop out voltage of VDD LDO	For TPS66121: $V_{IN} = 0\text{V}$, $V_{BUS} = 4.75\text{V}$, $I_{VBUS_LDO} = 30\text{ mA}$			0.5	V
ILIMIT_VBUS_LDO	Current limit VBUS LDO.	$V_{BUS} = 5.5\text{V}$, $V_{IN} = 0\text{V}$, $V_{LDO} = 0\text{V}$	50		100	mA

VBUS LDO Characteristics (continued)

Operating under these conditions unless otherwise noted: $-10\text{ }^{\circ}\text{C} \leq T_J \leq 125\text{ }^{\circ}\text{C}$, $2.85\text{V} \leq V_{\text{VIN}} \leq 5.5\text{V}$, $R_{\text{REF}} = 75\text{ k}\Omega \pm 1\%$ overall tolerance

PARAMETER		TEST CONDITIONS	MIN	TYP	MAX	UNIT
$t_{\text{EN_VBUS_LDO}}$	Turn-on time of VBUS LDO.	For TPS66120: $I_{\text{VBUS_LDO}} = 30\text{mA}$, $C_{\text{VLDO}} = 4.7\text{ }\mu\text{F}$, $V_{\text{IN}} = 0\text{V}$. Ramp V_{VBUS} from 0 to 5V at $\geq 50\text{V/ms}$. Measure from $V_{\text{BUS}} = 4.5\text{V}$ to $V_{\text{LDO}} = 3\text{V}$.			1.2	ms
		For TPS66121: $I_{\text{VBUS_LDO}} = 30\text{mA}$, $C_{\text{VLDO}} = 4.7\text{ }\mu\text{F}$, $V_{\text{IN}} = 0\text{V}$. Ramp V_{VBUS} from 0 to 7.5V at $\geq 50\text{V/ms}$. Measure from $V_{\text{BUS}} = 7\text{V}$ to $V_{\text{LDO}} = 4.5\text{V}$.			1.2	ms

6.9 Thermal Shutdown Characteristics

over operating free-air temperature range (unless otherwise noted)

PARAMETER		TEST CONDITIONS	MIN	TYP	MAX	UNIT
TSD_PPHV_R	Thermal Shutdown Temperature of the PPHV power path.	Temperature rising	128	150	172	$^{\circ}\text{C}$
TSD_PPHV_F	Thermal Shutdown Temperature of the PPHV power path.	Temperature falling	115	140	165	$^{\circ}\text{C}$
TSDH_PPHV	Thermal Shutdown hysteresis of the PPHV power path.			10		$^{\circ}\text{C}$
TSD_MAIN_R	Thermal Shutdown Temperature of the entire device.	Temperature rising	140	160	178	$^{\circ}\text{C}$
TSD_MAIN_F	Thermal Shutdown Temperature of the entire device.	Temperature falling	120	140	160	$^{\circ}\text{C}$
TSDH_MAIN	Thermal Shutdown hysteresis of the entire device.			20		$^{\circ}\text{C}$

6.10 Input-output (I/O) Characteristics

Operating under these conditions unless otherwise noted: $-10\text{ }^{\circ}\text{C} \leq T_J \leq 125\text{ }^{\circ}\text{C}$, $2.85\text{V} \leq V_{\text{VIN}} \leq 5.5\text{V}$, $R_{\text{REF}} = 75\text{ k}\Omega \pm 1\%$ overall tolerance

PARAMETER		TEST CONDITIONS	MIN	TYP	MAX	UNIT
EN_Vt+	Positive going input-threshold voltage, % of VLDO	$V_{\text{LDO}} = 2.85 - 5.5\text{V}$	40		70	%
EN_Vt-	Negative going input-threshold voltage, % of VLDO	$V_{\text{LDO}} = 2.85 - 5.5\text{V}$	30		60	%
EN_HYS	Input hysteresis voltage, % of VLDO	$V_{\text{LDO}} = 2.85 - 5.5\text{V}$		10		%
EN_RPD	Pull-down resistance EN pin.	Measured with pin voltage $V_{\text{EN}} = 3.3\text{V}$	500	650	800	$\text{k}\Omega$
EN_CLAMP	Voltage clamp on EN pin.	$I_{\text{EN}} = 100\text{ }\mu\text{A}$		6	7.1	V
FLT_VOL	Output Low Voltage, $\overline{\text{FLT}}$ pin	$I_{\text{OL}} = 2\text{mA}$, $\overline{\text{FLT}}$ driven low.			0.4	V
FLT_ILKG	Leakage Current, $\overline{\text{FLT}}$ pin	$\overline{\text{FLT}}$ not driven low.	-1		1	μA
$t_{\text{H_FLT}}$	Time $\overline{\text{FLT}}$ pin remains asserted low.		4	10	16	ms
$t_{\text{DG_EN}}$	Enable deglitch filter. Pulses on $\text{EN}0 < t_{\text{DG_EN(MIN)}}$ are not propagated to the control logic. Pulses on $\text{EN}0 > t_{\text{DG_EN(MAX)}}$ are propagated to the control logic. Pulses on $\text{EN}0 \geq t_{\text{DG_EN(MIN)}}$ and $\leq t_{\text{DG_EN(MAX)}}$ may or may not propagate to the control logic.		78		242	μs

6.11 Power Consumption Characteristics

Operating under these conditions unless otherwise noted: $-10\text{ }^{\circ}\text{C} \leq T_J \leq 85\text{ }^{\circ}\text{C}$, $2.85\text{V} \leq V_{VIN} \leq 5.5\text{V}$, $R_{IREF} = 75\text{ k}\Omega \pm 1\%$ overall tolerance

PARAMETER		TEST CONDITIONS		MIN	TYP	MAX	UNIT
$I_{VIN_DISABLE}$	Current consumed by $V_{IN}^{(1)}$	$V_{IN} = 3.3\text{V}$, $V_{BUS} = 0\text{V}$, $PPHV = 0\text{V}$, DISABLED state. Measure I_{VIN} . TPS66120 only.			19	27	μA
		$V_{IN} = 5\text{V}$, $V_{BUS} = 0\text{V}$, $PPHV = 0\text{V}$, DISABLED state. Measure I_{VIN} . TPS66121 only.			25	36	μA
I_{VIN_SNK}	Current consumed by $V_{IN}^{(1)}$	$V_{IN} = 3.3\text{V}$, SNK state. Measure I_{VIN} . TPS66120 only.	$V_{BUS} = 5.5\text{V}/22\text{V}$		130		μA
		$V_{IN} = 5\text{V}$, SNK state. Measure I_{VIN} . TPS66121 only.	$V_{BUS} = 5.5\text{V}/22\text{V}$		215		μA
I_{SD_VBUS}	Current consumed by $V_{BUS}^{(1)}$	$V_{IN} = 3.3\text{V}$, $PPHV = 0\text{V}$, DISABLED state. Measure I_{VBUS} . TPS66120 only.	$V_{BUS} = 5.5\text{V}$		12	26	μA
			$V_{BUS} = 22\text{V}$		34		μA
		$V_{IN} = 5\text{V}$, $PPHV = 0\text{V}$, DISABLED state. Measure I_{VBUS} . TPS66121 only.	$V_{BUS} = 5.5\text{V}$		8		μA
			$V_{BUS} = 22\text{V}$		30		μA
$I_{SD_VBUS_LDO}$	Current consumed by $V_{BUS}^{(1)}$	$V_{IN} = 0\text{V}$, $PPHV = 0\text{V}$, DISABLED state. Measure I_{VBUS} .	$V_{BUS} = 5.5\text{V}$		45		μA
			$V_{BUS} = 22\text{V}$		68		μA
$I_{SD_VBUS_LDO}$	Current consumed by $V_{BUS}^{(1)}$	$V_{IN} = 0\text{V}$, $PPHV = 0\text{V}$, DISABLED state. Measure I_{VBUS} .	$V_{BUS} = 5.5\text{V}$		45		μA
			$V_{BUS} = 22\text{V}$		69		μA
I_{ACT_VBUS}	Current consumed by $V_{BUS}^{(1)}$	$V_{IN} = 3.3\text{V}$, SNK state. Measure I_{VBUS} . TPS66120 only.	$V_{BUS} = 5.5\text{V}$		325		μA
			$V_{BUS} = 22\text{V}$		360		μA
		$V_{IN} = 5\text{V}$, SNK state. Measure I_{VBUS} . TPS66121 only.	$V_{BUS} = 5.5\text{V}$		342		μA
			$V_{BUS} = 22\text{V}$		377		μA
V_{OC_VBUS}	Open circuit voltage, V_{BUS}	$PPHV = 22\text{V}$, DISABLED state, no DC loading on V_{BUS} . Measure V_{VBUS} under steady state conditions.				0.8	V
V_{OC_PPHV}	Open circuit voltage, $PPHV$	$V_{BUS} = 22\text{V}$, DISABLED state, no DC loading on $PPHV$. Measure V_{PPHV} under steady state conditions.				0.8	V

(1) Measured with EN0 set to GND or VLDO levels as required for the respective state.

6.12 Typical Characteristics

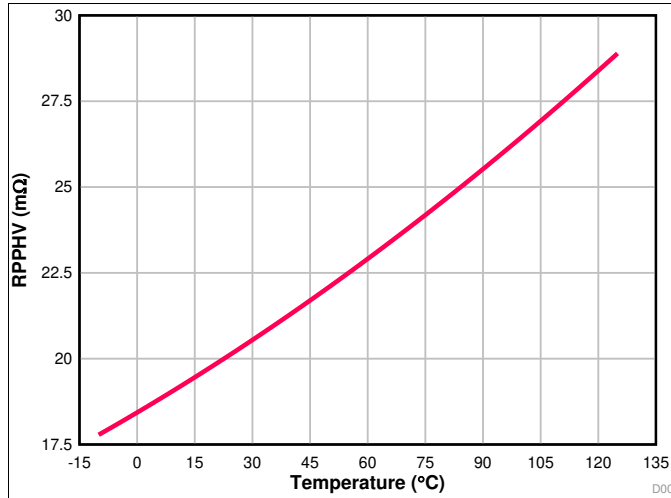

Figure 1. R_{PPHV} versus Temperature

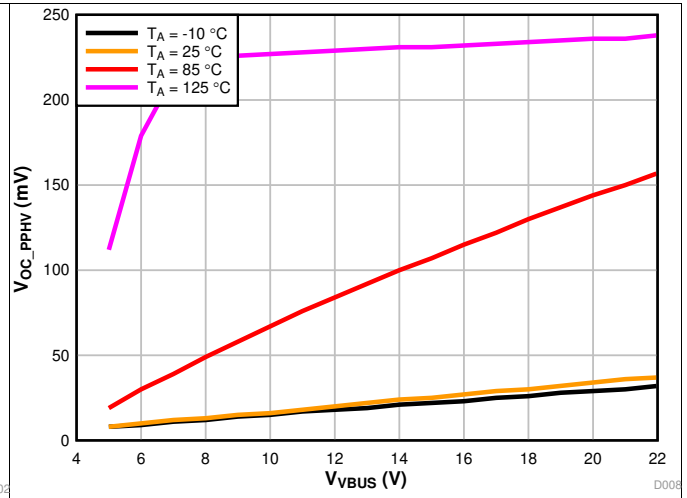

Figure 2. V_{OC_PPHV}, PPHV Open Circuit Voltage versus V_{BUS}

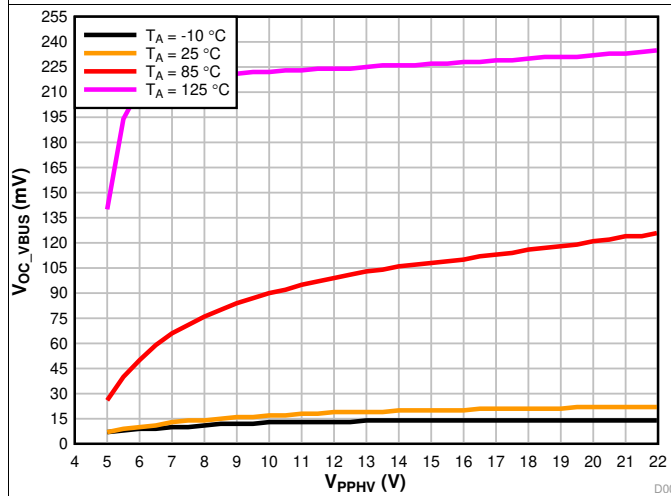

Figure 3. V_{OC_VBUS}, V_{BUS} Open Circuit Voltage versus V_{PPHV}

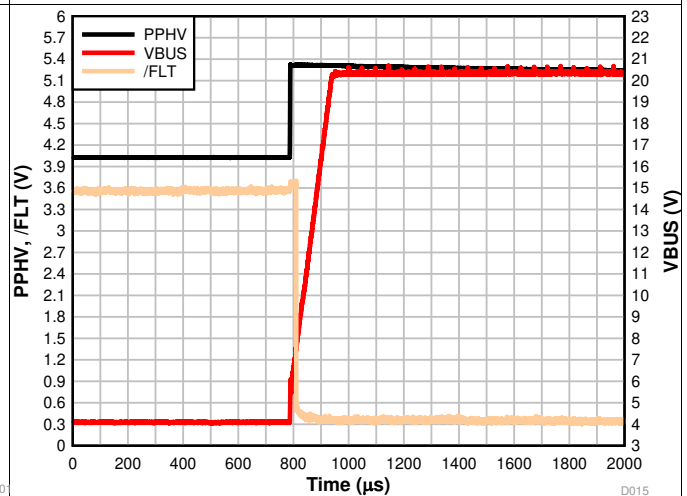

Figure 4. V_{BUS} OVP Response with 6-V Threshold

7 Detailed Description

7.1 Overview

The TPS6612x is a fully featured integrated Sink power path with a high voltage VBUS LDO voltage regulator. The Sink power path can support up to 5 A at 20 V controlled by a general-purpose I/O. The Sink power path includes soft-start to minimize in-rush currents, overtemperature protection, reverse-current protection, undervoltage protection, and an optional overvoltage protection configured in the application. See the [20-V Sink \(PPHV Power Path\)](#) section.

The VBUS low dropout voltage regulator may be used in systems that require power during dead battery conditions and can provide up to 30 mA to the system via the VLDO pin. Once VIN power is available, VLDO pin power is switched from the VBUS LDO regulator to the VIN pin. The TPS66120 devices VBUS LDO regulator nominally supplies 3.3 V where the TPS66121 device VBUS LDO regulator nominally supplies 5 V. See the [Power Management and Supervisory](#) section.

7.2 Functional Block Diagram

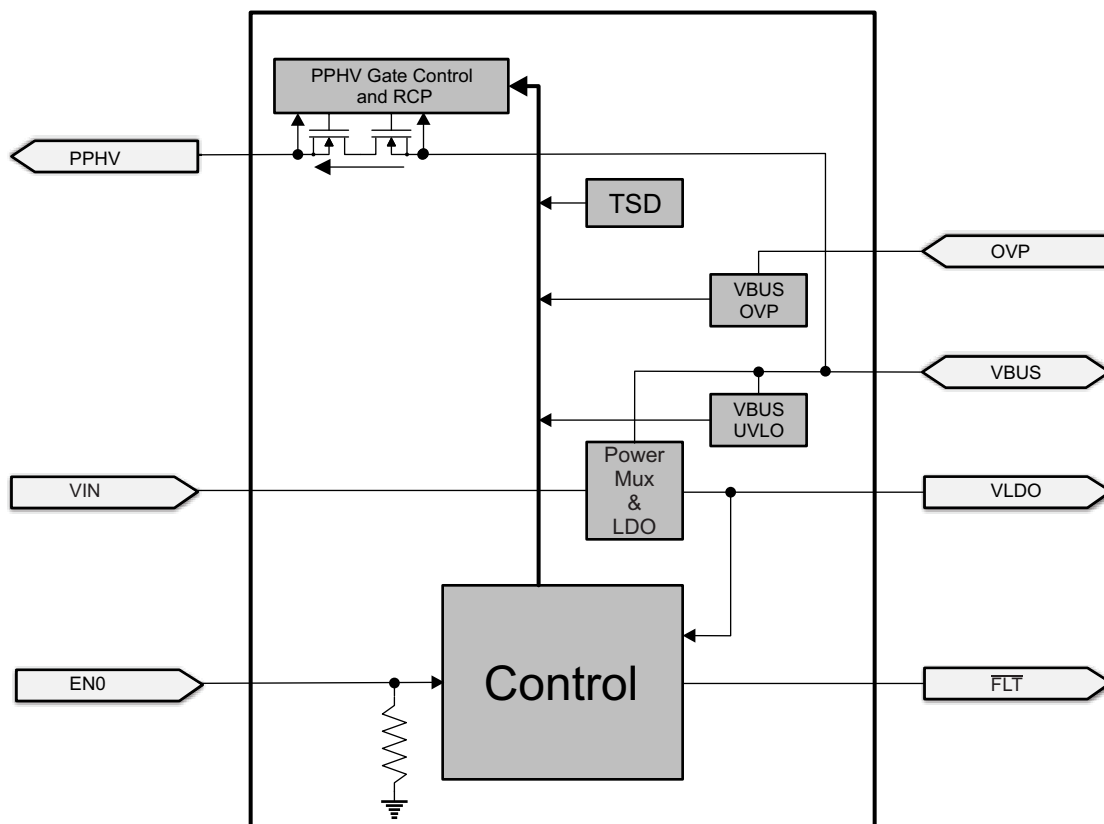

7.3 Feature Description

7.3.1 20-V Sink (PPHV Power Path)

The PPHV path is a Sink only path, providing power from the VBUS terminal to the PPHV terminal when enabled. The PPHV power path uses two back-to-back N-channel MOSFETs, and blocks current in both directions when the power path is disabled.

7.3.1.1 PPHV Soft Start

The TPS6612x PPHV power path has soft start circuitry to control in-rush current when the PPHV power path is enabled. DC loading should be minimized during soft start since the PPHV path may experience high power dissipation especially at higher VBUS voltages. This may lead to a PPHV overtemperature protection event.

Feature Description (continued)

7.3.1.2 PPHV Reverse Current Protection (RCP)

When the PPHV power path is enabled, the RCP circuitry monitors the voltage across the path. If the RCP monitor detects $V_{PPHV} - V_{VBUS} \geq V_{RCP_THRES_PPHV}$, the PPHV path will be disabled preventing additional current flow from PPHV to VBUS. The power path will be completely disabled and remain disabled as long as the RCP condition persists. After the RCP event, the PPHV path will automatically re-enable. FLT is not asserted when a reverse current protection event occurs on the PPHV path.

7.3.2 Overtemperature Protection

The PPHV power path has an integrated temperature sensor to protect it from excessive heating. When the sensor in the path detects an overtemperature condition, the PPHV path will be automatically disabled (if enabled) and cannot be enabled until the overtemperature condition has been removed. FLT is asserted when an overtemperature event occurs.

In addition, the device has an integrated main temperature sensor. When the sensor detects an overtemperature condition, the PPHV power path and the VBUS LDO of the device are completely disabled until the overtemperature condition has been removed.

7.3.3 VBUS Overvoltage Protection (OVP)

TPS6612x supports overvoltage protection on the VBUS terminal. When the voltage detected on OVP exceeds a set level, the PPHV power path will automatically be disabled (if enabled), and will remain disabled until the OVP event is removed. FLT is asserted when an overvoltage event occurs. The VBUS OVP threshold may be set using a resistor divider from VBUS to GND, whose divider output is connected to the OVP terminal as shown in Figure 5. Table 1 shows resistor divider settings for common USB Power Delivery fixed voltage supply contracts along with the resulting nominal OVP thresholds. These thresholds may be adjusted based on desired margins for a given application. If VBUS OVP is not required or needs to be disabled, the OVP terminal may be tied or driven to GND as shown in Figure 6. Lastly, as one example implementation, the OVP threshold may be controlled dynamically using outputs from a PD controller or microcontroller as shown in Figure 7. By selecting each output, different VBUS OVP threshold settings are possible.

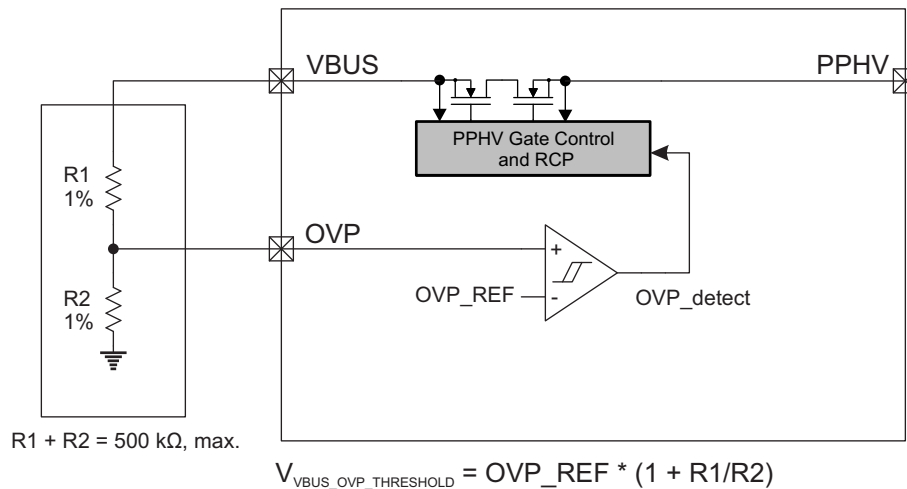

Figure 5. VBUS OVP Threshold Set by External Resistor Divider

Table 1. Typical External Resistor Divider Settings

PD Fixed Contract	R1, kΩ	R2, kΩ	Nominal VBUS OVP Threshold, V
5 V	102	20	6.1
9 V	182	20	10.1
15 V	309	20	16.5
20 V	432	20	22.6

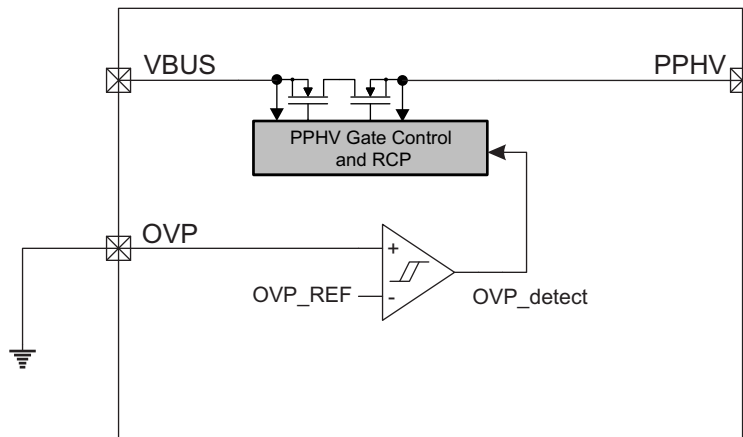

Figure 6. VBUS OVP Disabled

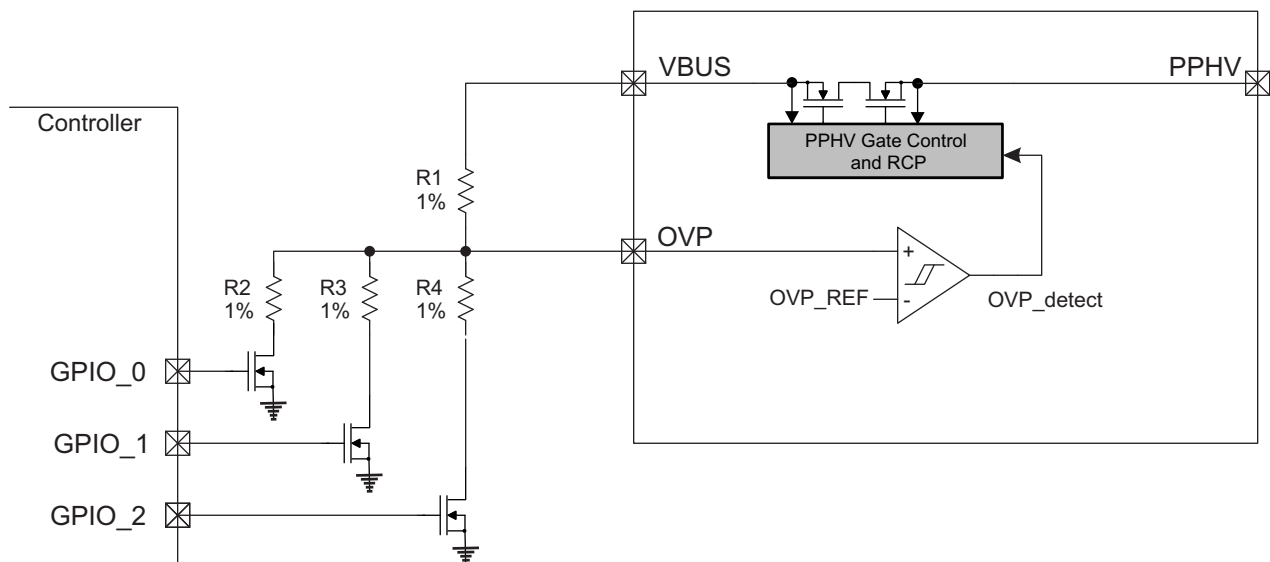

Figure 7. Selectable VBUS OVP Thresholds

7.3.4 Power Management and Supervisory

The TPS6612x Power Management block receives power from VIN or VBUS and generates voltages to provide power to the TPS6612x internal circuitry, as well as, provides power to VLDO. The power supply management and supervisory block is shown in [Figure 8](#).

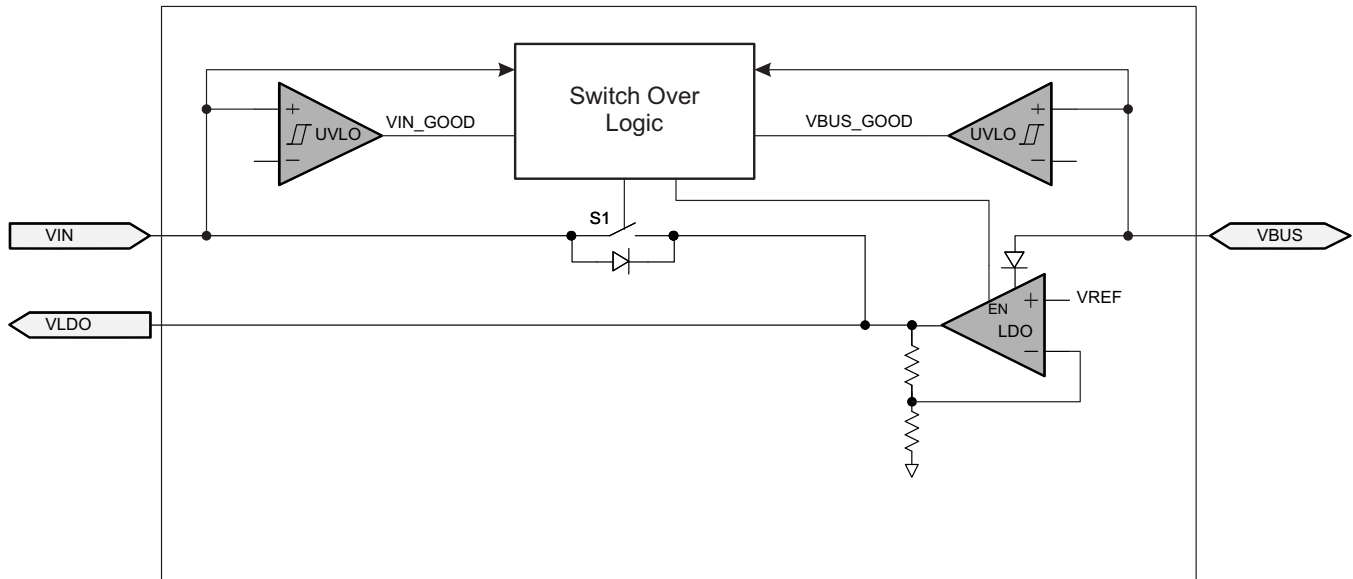

Figure 8. Power Management and Supervisory

The VLDO terminal may be powered from either VIN or VBUS. The normal power supply input is VIN. When VIN is present, S1 is closed and current flows from VIN to VLDO and the VBUS LDO is disabled. When VIN power is unavailable, as in a dead battery condition, the VBUS LDO will be automatically enabled when VBUS is present, and the VLDO terminal is powered by the VBUS LDO. The Switch Over Logic provides the decision making capability to choose VIN or VBUS power, depending on the state of these voltages (based on their respective UVLO comparators) and their relative levels to each other.

7.3.4.1 Supply Connections

Figure 9 shows the TPS66120 VIN being supplied from a 3.3-V supply. The VLDO output may or may not be used to supply other circuitry in the application, for example a PD Controller. During dead battery, the internal 3.3-V VBUS LDO provides power to the TPS66120 and the VLDO output. Once VIN input supply becomes available, the VBUS LDO is disabled and VIN provides power to the VLDO output.

Figure 10 shows the TPS66121 VIN being supplied from a 5-V supply. The VLDO output may or may not be used to supply power to external circuitry. During dead battery, the internal 5-V VBUS LDO provides power to the TPS66121 and the VLDO output. Once VIN input supply becomes available, the VBUS LDO is disabled and VIN provides power to the VLDO output.

Another option is to power the TPS66120 from the VBUS LDO only as shown in Figure 11. Since VIN is tied to GND, power to the TPS66120 is provided by the 3.3-V VBUS LDO when VBUS power is present. The VLDO output may be used optionally to supply power to external circuitry.

Similarly, Figure 12 shows the TPS66121 being powered from the VBUS LDO only. Since VIN is tied to GND, power to the TPS66121 is provided by the 5-V VBUS LDO when VBUS power is present. The VLDO output may be used optionally to supply power to external circuitry.

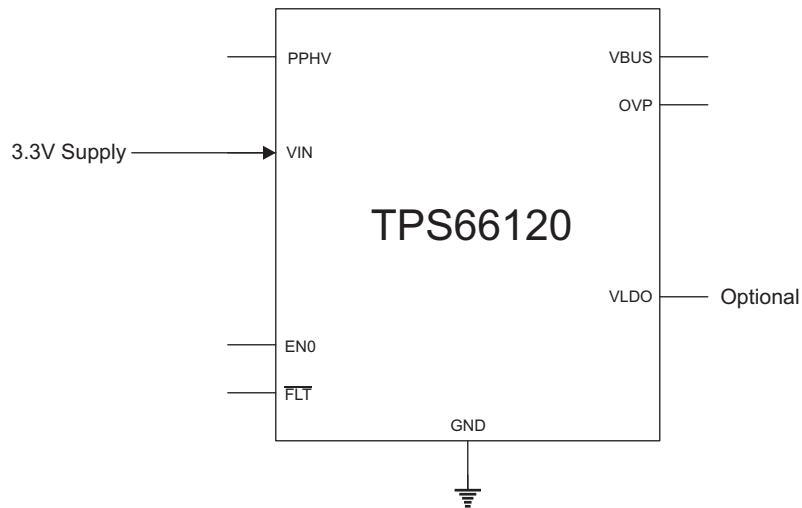

Figure 9. TPS66120 VIN 3.3-V Supply

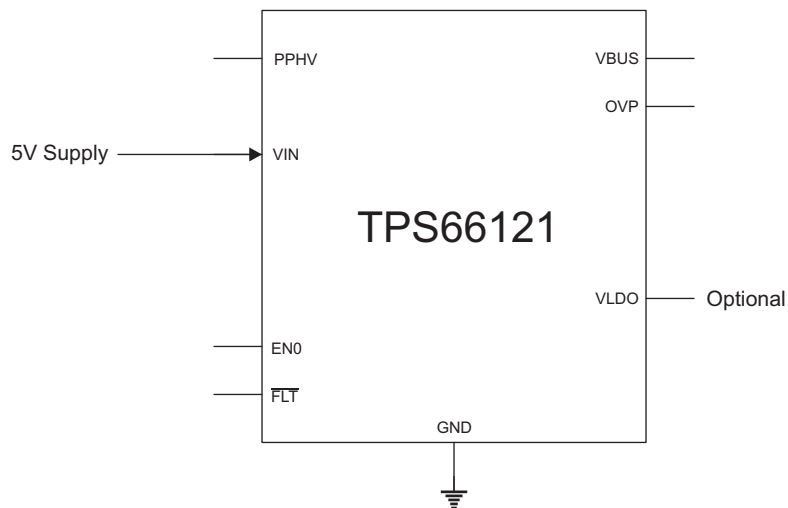

Figure 10. TPS66121 VIN 5-V Supply

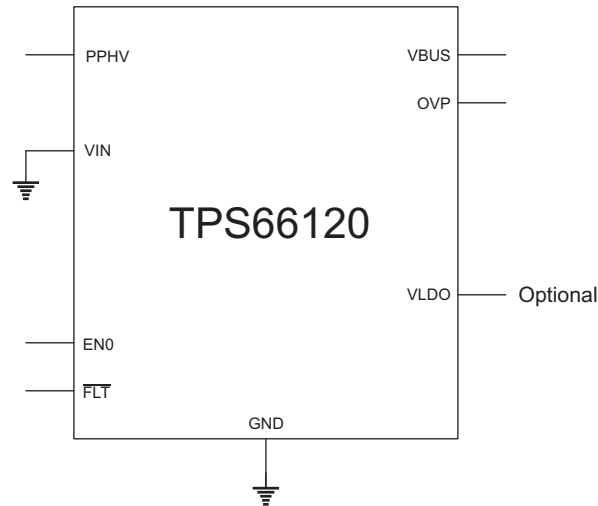

Figure 11. TPS66120 VBUS Powered

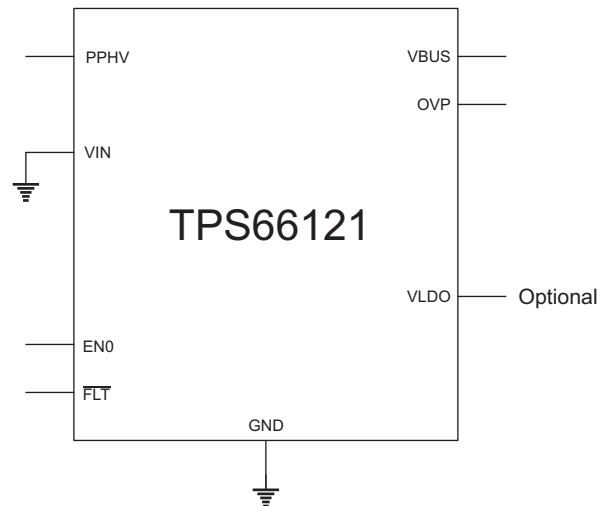

Figure 12. TPS66121 VBUS Powered

7.3.4.2 Power Up Sequences

7.3.4.2.1 Normal Power Up

Figure 13 shows a typical power up sequence. During normal power up, VIN supplies power to the TPS6612x. In this case, VBUS remains powered down. It is assumed a PD Controller is controlling the TPS6612x, and Sink operation is being requested.

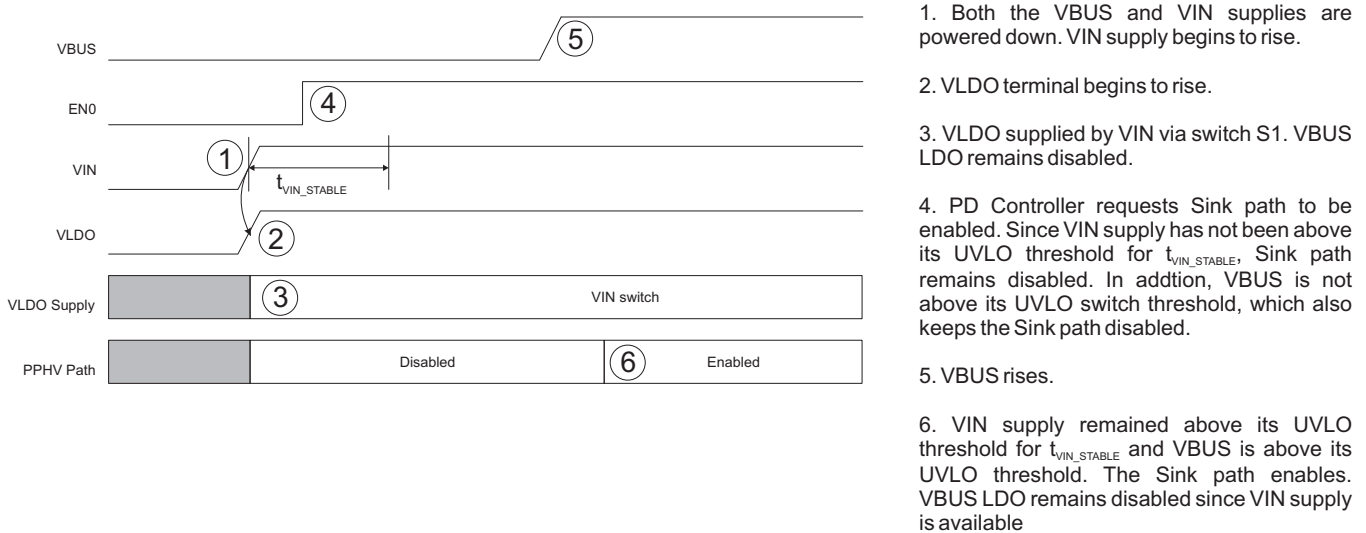

Figure 13. Normal Power Up Sequence

7.3.4.2.2 Dead Battery Operation

Figure 14 shows the typical power up sequence during a dead battery condition. During a dead battery condition, the TPS6612x is internally powered by the VBUS LDO. The VBUS LDO may be used to supply a limited amount of current for use in the system during dead battery, such as supplying power to a PD controller. In this case, it is assumed the VLDO terminal is providing power to a PD controller that is controlling the TPS6612x. Once VIN is stable, the VLDO terminal switches from being supplied by the VBUS LDO to being supplied by the VIN terminal, and the VBUS LDO is automatically disabled. The switch over process is completely seamless.

NOTE

Switching from VBUS LDO operation to VIN operation is seamless and no device reset will occur. When switching from VIN power to VBUS LDO operation, the switch over circuitry will attempt to switch over to the VBUS LDO, however it is not assured that the VLDO level will be maintained above the VLDO UVLO threshold. In this case, a device reset may or may not occur.

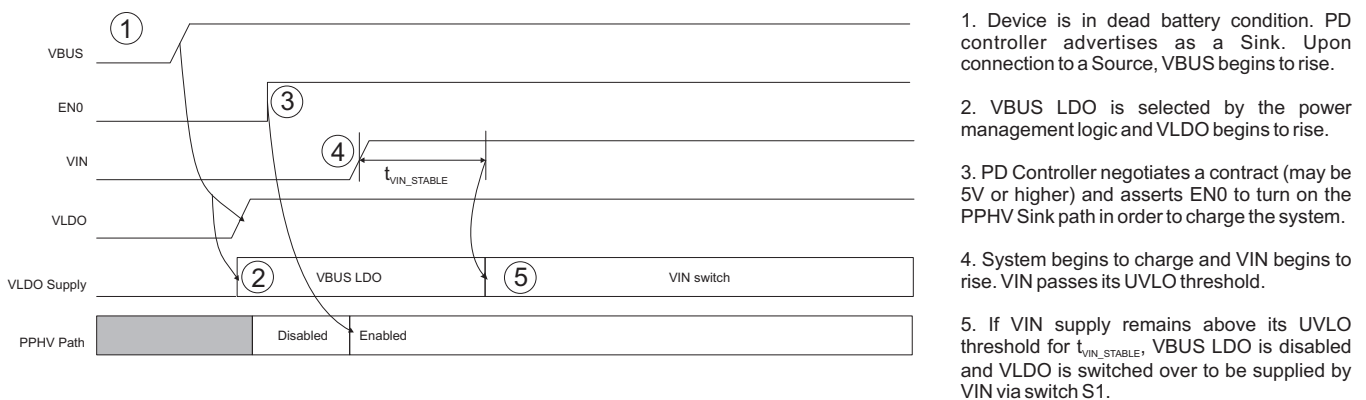

Figure 14. Dead Battery Power Up Sequence

7.4 Device Functional Modes

7.4.1 State Transitions

EN0 is used by the application to control the state of the device. Figure 15 shows the supported state transitions.

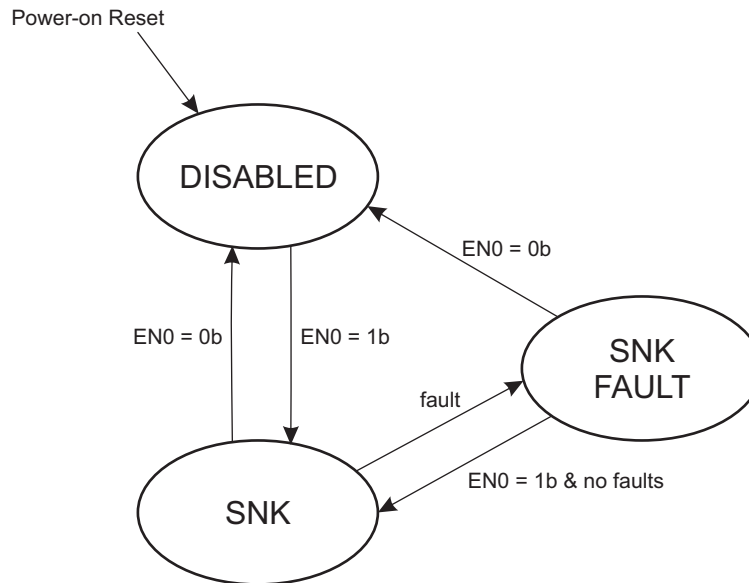

Figure 15. TPS6612x State Diagram

7.4.1.1 DISABLED State

In the DISABLED state, EN0 = 0. While in the DISABLED state:

- PPHV power path is disabled
- PPHV overtemperature, reverse-current, and VBUS overvoltage protections are disabled
- VIN and VBUS undervoltage lockout are enabled
- SNK state if (EN1 = 0) and (EN0 = 1) and (VBUS UVLO event not detected)

7.4.1.2 SNK State

In the SNK state, EN0 = 1. While in the SNK state:

- PPHV power path is enabled
- PPHV overtemperature, VBUS overvoltage (if OVP terminal not grounded) and reverse-current protections are enabled
- VIN and VBUS undervoltage lockout are enabled
- DISABLED state if:
 - (EN1 = 0) and (EN0 = 0)
- SNK FAULT state if:
 - VBUS OVP (if OVP terminal not grounded) event detected -or-
 - PPHV TSD event detected

7.4.2 SNK FAULT State

The SNK FAULT state is entered when any PPHV fault event is detected. Upon entering the SNK FAULT state, the PPHV power path is disabled. The following transitions are possible from the SNK FAULT state:

- DISABLED state if:
 - (EN0 = 0)
- SNK state if:
 - (EN0 = 1) -and-

Device Functional Modes (continued)

- PPHV TSD, VBUS OVP (if OVP terminal not grounded) events are not detected

7.4.3 Device Functional Mode Summary

Table 2 summarizes the functional modes for the TPS6612x family. As shown, the enabling and disabling of the Sink is dependent upon the voltage present on VBUS, as well as, the current device state.

Table 2. TPS6612x Device Functional Modes⁽¹⁾

ENO	VIN	V _{VBUS}	FLT	Device State	Sink Path
0	≥ UV_VIN	X	Hi-Z	DISABLED	Disabled Safety engaged.
1	≥ UV_VIN	≥ UV_VBUS	Hi-Z	SNK	Enabled RCP, OVT enabled
			Hi-Z	SNK FAULT	Enabled with Blocking RCP event.
			L	SNK FAULT	Disabled OVP ⁽²⁾ or OVT event.
		< UV_VBUS	Hi-Z	SNK FAULT	Disabled VBUS UVLO event.
X	< UV_VIN	< UV_VBUS	Hi-Z	DISABLED	Disabled Safety engaged.
0	< UV_VIN	≥ UV_VBUS	Hi-Z	DISABLED	Disabled Safety engaged.
1	< UV_VIN	≥ UV_VBUS ⁽³⁾	Hi-Z	SNK	Enabled RCP, OVT enabled
			Hi-Z	SNK FAULT	Enabled with Blocking RCP event.
			L	SNK FAULT	Disabled OVP ⁽²⁾ or OVT event.
		< UV_VBUS ⁽³⁾	Hi-Z	SNK FAULT	Disabled VBUS UVLO event.

(1) X: do-not-care.

(2) When OVP function used and VBUS exceeds OVP threshold, V_{VBUS_OVP_THRESHOLD}.

(3) If VIN supply is not available, then VIN may be tied to GND. In this case VLDO is supplying power to the device.

7.4.4 Enabling the PPHV Sink Path

The timing diagram of enabling the PPHV Sink path is shown in Figure 16.

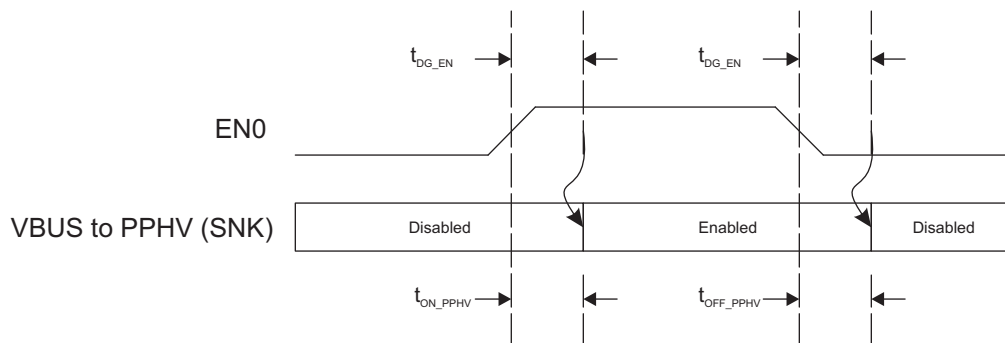

Figure 16. Enabling the PPHV Sink Path

7.4.5 Faults

The TPS6612x includes a fault pin, $\overline{\text{FLT}}$. The $\overline{\text{FLT}}$ pin is an open-drain output and requires an external pull-up resistor. If the $\overline{\text{FLT}}$ pin is not required, it may be tied to GND or left floating. The $\overline{\text{FLT}}$ pin will be asserted low only under certain conditions and not all fault conditions will assert the $\overline{\text{FLT}}$ pin, see Table 3. If the $\overline{\text{FLT}}$ pin is asserted, it will remain asserted for a minimum of $t_{\text{HOLD_FLT}}$ regardless if the fault condition is removed. After $t_{\text{HOLD_FLT}}$, if all fault conditions have surpassed, the $\overline{\text{FLT}}$ pin is released.

7.4.5.1 Fault Types

Table 3 summarizes the various fault types available and when the $\overline{\text{FLT}}$ shall be asserted.

Table 3. Fault Types

Fault Name	Fault	$\overline{\text{FLT}}$	Description
VBUS_UVLO	VBUS undervoltage Lockout	Hi-Z	If VBUS supply is below the VBUS UVLO threshold, the PPHV path is disabled automatically if enabled or remains disabled. If the SNK state is selected to be entered, the device will remain in the DISABLED state until the UVLO event is removed. If the SNK state has been entered successfully and a UVLO event occurs, the PPHV path is disabled automatically.
VBUS_OVP ⁽¹⁾	VBUS overvoltage Protection	Low	If the SNK state is selected to be entered or device currently is in the SNK state and the VBUS supply rises above the VBUS OVP threshold, the PPHV path is disabled automatically and the $\overline{\text{FLT}}$ pin will be asserted.
VBUS_RCP	VBUS Reverse-Current Protection	Hi-Z	If the SNK state is selected to be entered or device currently is in the SNK state and a reverse-current condition is detected, the PPHV path is disabled automatically, but the $\overline{\text{FLT}}$ is not asserted. If the reverse-current condition is removed, the PPHV path will automatically re-enable.
PPHV_OVT	PPHV overtemperature Protection	Low	If the SNK state is selected to be entered or device currently is in the SNK state and the local temperature of PPHV power path exceeds TSD_PPHV_R , the PPHV path is disabled automatically and the $\overline{\text{FLT}}$ pin will be asserted. PPHV power path will remain disabled until temperature falls below TSD_PPHV_F .

(1) OVP terminal is not connected to GND.

8 Application and Implementation

NOTE

Information in the following applications sections is not part of the TI component specification, and TI does not warrant its accuracy or completeness. TI's customers are responsible for determining suitability of components for their purposes. Customers should validate and test their design implementation to confirm system functionality.

8.1 Application Information

The typical applications of the TPS6612x include chargers, notebooks, tablets, ultra-books, dongles and any other product supporting USB Type-C and/or USB-PD as a power source or power sink. The typical applications outlined in the following sections detail a Fully-Featured USB Type-C using a single 5-V supply and another using a separate 3.3-V supply.

8.2 Typical Application

Figure 17 shows a USB Type-C single port design using a power delivery controller. For this system, a single 5-V supply in the system is used to supply power to the external load switch, as well as, the connector VCONN power. The VIN terminal of the TPS66121 is tied to GND and the TPS66121 is powered by the VBUS LDO once VBUS is present. In addition, the TPS66121 supplies power to the 5-V supply of the PD controller via the VLDO output. The PPHV integrated power path provides power to the system and battery charger from VBUS when the TPS66121 Sink path is enabled. An external 5-V load switch is shown to provide power to VBUS when system is configured as a Source.

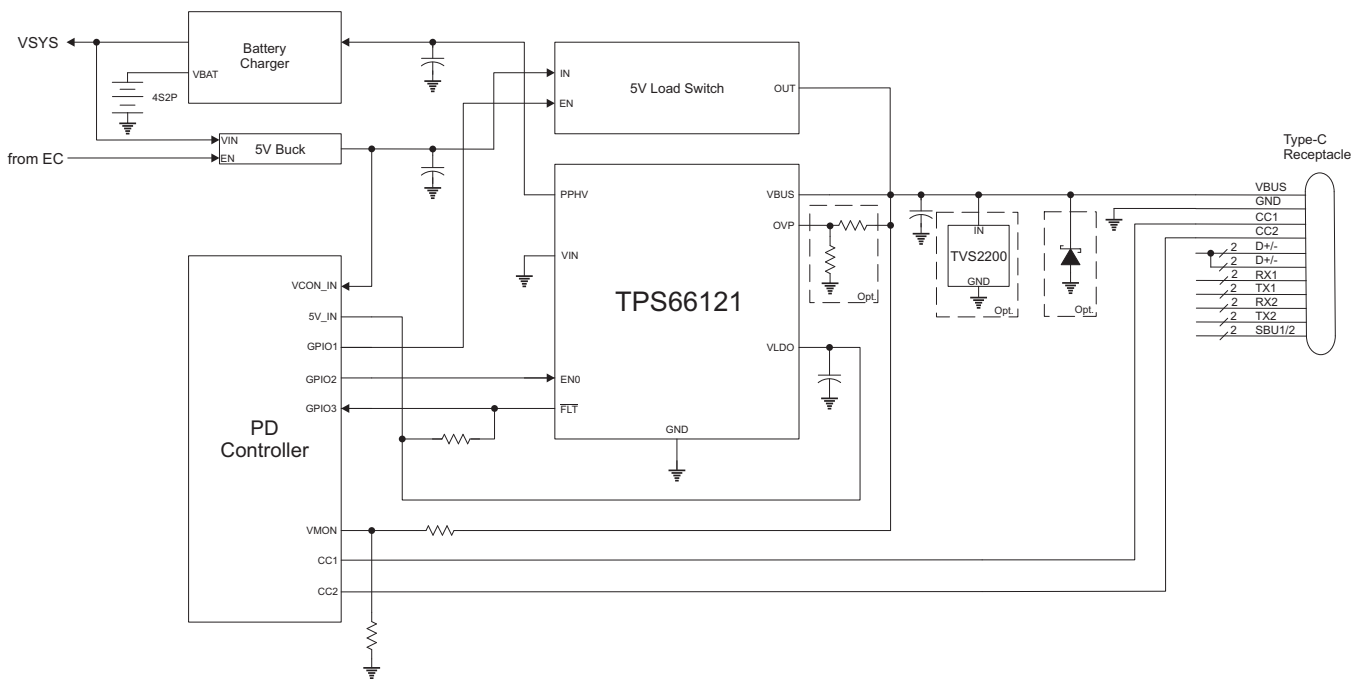

Figure 17. Single Port Type-C PD Port Using a 5-V Supply.

8.2.1 Design Requirements

For a single port notebook application, Table 4 lists the input voltage requirements and expected current capabilities.

Typical Application (continued)

Table 4. Single-Port Notebook Application Design Parameters

DESIGN PARAMETERS	EXAMPLE VALUE(S)	POWER PATH DIRECTION
5-V Load Switch Voltage and Current Capabilities	5V/3A	Source from 5-V load switch to VBUS
VCON_IN Input Voltage and Current Capabilities	5V/300mA (1.5W)	Source to VCONN
VBUS Input Voltage and Current Capabilities	5V/3A, 9V/3A, 15V/3A, 20V/3A	Sink from VBUS to PPHV
5V_IN Input Voltage and Current Capabilities	4.5-5.5V/30mA	5-V PD Controller Supply
3V_IN Input Voltage and Current Capabilities	3.0-3.6V/30mA	3.3-V PD Controller Supply

8.2.2 Detailed Design Procedure

8.2.2.1 External VLDO Capacitor (CVLDO)

For all capacitances, the DC operating voltage must be factored into the derating of ceramic capacitors. Generally, the effective capacitance is 35-50% of the nominal capacitance with voltage applied. Assuming VLDO = 5 V, and a minimum derated capacitance of 2.5 μ F, a 10-V rated 4.7- μ F capacitor is sufficient.

8.2.2.2 PPHV, VBUS Power Path Capacitance

The PPHV power path is a Sink. The capacitance on the PPHV shown in [Figure 17](#) represents capacitance of the charger sub-system. In a typical application, this capacitance can be in the range of 47 μ F up to 100 μ F, far exceeding the 1- μ F minimum specification for the TPS6612x, so no external capacitance is required to meet this requirement in most cases. As per the PD Specification, the total capacitance on VBUS should be maximum 10 μ F at connection.

The TPS6612x PPHV power path has soft start circuitry to control in-rush current when the PPHV power path is enabled. DC loading should be minimized during soft start since the PPHV path may experience high power dissipation especially at higher VBUS voltages. This in turn may lead to a PPHV overtemperature protection event.

8.2.2.3 VBUS TVS Protection (Optional)

It is recommended that each VBUS port in the system have TVS protection to protect the VBUS terminal. Inductive ringing during momentary disconnects and reconnects due to mechanical vibration or plug removal while sinking large current loads may cause large peak voltages to be present on the VBUS terminal that may exceed the absolute maximums of the TPS6612x. Under such events, the TVS2200 clamps the VBUS terminal and prevents VBUS from exceeding the maximum specification. The TVS trip point should be chosen to be safely above the normal operating ranges of the device. For this case, it is assumed VBUS voltage contracts are less than 22-V maximum which is below the minimum breakdown voltage of the TVS2200. The maximum clamping voltage of 28.3 V of the TVS2200 is sufficient to protect the VBUS terminal of the TPS6612x.

8.2.2.4 VBUS Schottky Diode Protection (Optional)

To prevent the possibility of large ground currents into the TPS6612x during sudden disconnects because of inductive effects in a cable, it is recommended that a Schottky diode be placed from VBUS to GND. The NSR20F30NXT5G or comparable device is recommended.

8.2.2.5 VBUS Overvoltage Protection (Optional)

VBUS Overvoltage Protection (OVP) is optional. If VBUS OVP is not required, then the OVP terminal should be tied to ground as shown in [Figure 6](#). VBUS OVP is used to detect voltages on VBUS that exceed a set threshold. Upon detection, the PPHV power path is disabled quickly to help protect components connected downstream of the PPHV terminal. It should be noted that VBUS OVP is not a replacement for VBUS TVS protection which is protecting the VBUS terminal itself.

The VBUS OVP threshold is set by a resistor divider from the VBUS terminal to ground as shown in [Figure 5](#). For this design, R1 and R2 are fixed values to provide VBUS OVP protection at the highest voltage contract level. Using R1 = 432-k Ω and R2 = 20-k Ω sets a nominal VBUS OVP threshold of 22.6 V. For some applications, it may be desirable to dynamically change the VBUS OVP level based on the negotiated power contract. One possible way is shown in [Figure 7](#). In this case, the PD controller via GPIO, selects the proper divider ratio to set the VBUS OVP threshold based on the negotiated voltage contract level.

8.2.2.6 Dead Battery Support

The TPS6612x integrates a high-voltage VBUS LDO that can be used to supply power to a PD Controller and other supporting circuitry when only VBUS power is available, such as in a dead battery condition. As shown in [Figure 17](#) the TPS66121 VLDO output supplies power to the PD Controller's 5V_IN supply. During a dead battery condition, the PD Controller presents its Type-C RPD pull-downs on the CC1 and CC2 lines. Upon connection to a Type-C/PD Source, 5 V is provided to VBUS from the Source partner which powers the TPS6612x. The 5-V VBUS LDO is enabled and provides power to the PD Controller. Once powered, the PD Controller can decide to enable the TPS6612x PPHV Sink path by asserting EN0 high and use the 5-V VBUS to charge the battery or it may choose to negotiate a higher voltage contract first. Either way, once the contract is negotiated, the PD Controller will enable the PPHV Sink path and charge the system. Once the system is sufficiently charged, the VIN terminal will rise and will exceed the VIN UVLO threshold. If VIN remains above the UVLO threshold for t_{VIN_STABLE} , VLDO will be supplied from VIN and the VBUS LDO will be disabled.

8.2.3 Application Curves

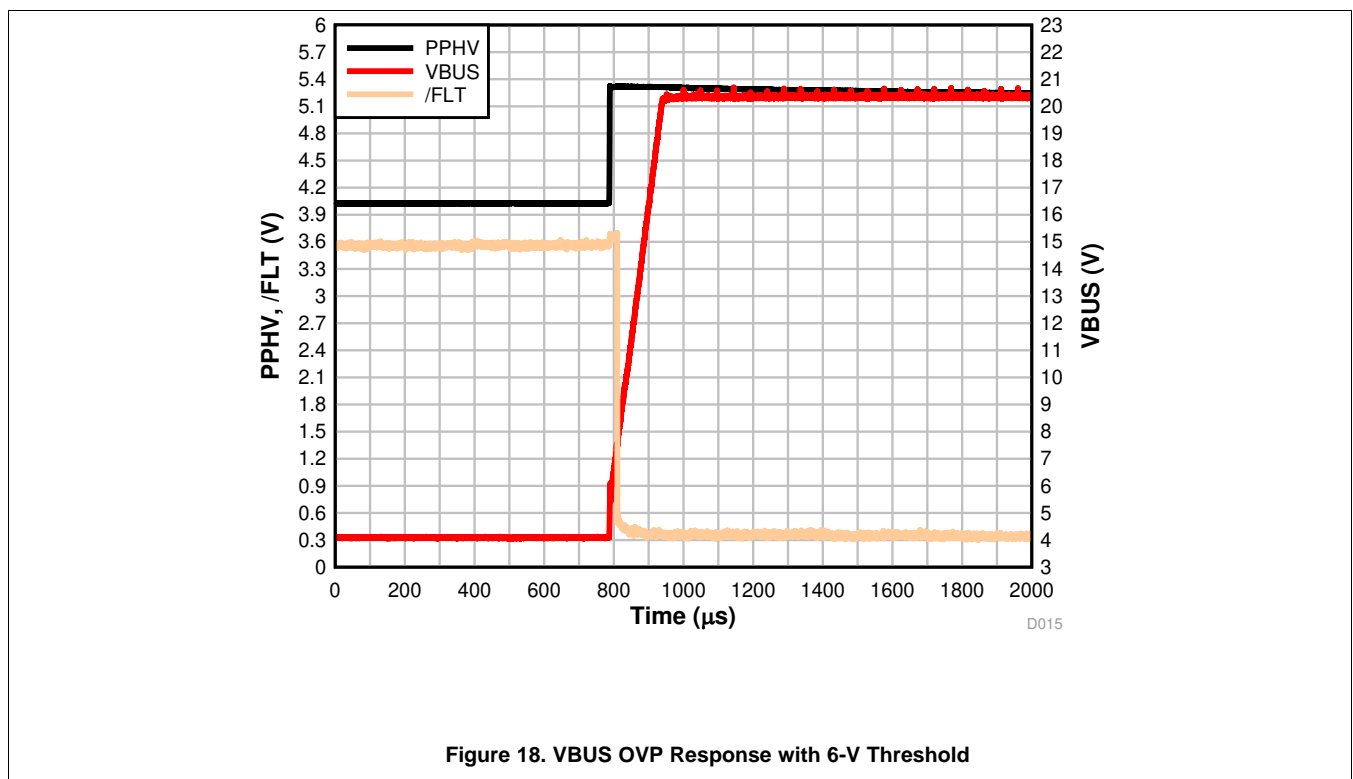

9 Power Supply Recommendations

The device has a single input supply, VIN. A 1- μ F or higher ceramic bypass capacitor between VIN and GND is recommended as close to the VIN as possible for local noise decoupling.

USB Specification Revisions 2.0 and 3.1 require VBUS voltage at the connector to be between 4.75 V to 5.5 V. Depending on layout and routing from supply to the connector the voltage droop on VBUS has to be tightly controlled. Locate the input supply close to the device. For all applications, a maximum 10- μ F ceramic bypass capacitor between VBUS and GND is recommended as close to the Type-C connector of the device as possible for local noise decoupling. The input power supply should be rated higher than the current limit set to avoid voltage droops during overcurrent and short-circuit conditions.

10 Layout

10.1 Layout Guidelines

1. PPHV and VBUS traces must be as short and wide as possible to accommodate for high currents.
2. A ceramic 4.7 uF (X7R/X5R) 10-V rated capacitor is placed as close as possible to the VLDO terminal of the TPS6612x.

10.2 Layout Example



Figure 19. Layout Example

11 Device and Documentation Support

11.1 Related Links

The table below lists quick access links. Categories include technical documents, support and community resources, tools and software, and quick access to order now.

Table 5. Related Links

PARTS	PRODUCT FOLDER	ORDER NOW	TECHNICAL DOCUMENTS	TOOLS & SOFTWARE	SUPPORT & COMMUNITY
TPS66120	Click here	Click here	Click here	Click here	Click here
TPS66121	Click here	Click here	Click here	Click here	Click here

11.2 Receiving Notification of Documentation Updates

To receive notification of documentation updates, navigate to the device product folder on ti.com. In the upper right corner, click on *Alert me* to register and receive a weekly digest of any product information that has changed. For change details, review the revision history included in any revised document.

11.3 Support Resources

[TI E2E™ support forums](#) are an engineer's go-to source for fast, verified answers and design help — straight from the experts. Search existing answers or ask your own question to get the quick design help you need.

Linked content is provided "AS IS" by the respective contributors. They do not constitute TI specifications and do not necessarily reflect TI's views; see TI's [Terms of Use](#).

11.4 Trademarks

E2E is a trademark of Texas Instruments.

All other trademarks are the property of their respective owners.

11.5 Electrostatic Discharge Caution



This integrated circuit can be damaged by ESD. Texas Instruments recommends that all integrated circuits be handled with appropriate precautions. Failure to observe proper handling and installation procedures can cause damage.

ESD damage can range from subtle performance degradation to complete device failure. Precision integrated circuits may be more susceptible to damage because very small parametric changes could cause the device not to meet its published specifications.

11.6 Glossary

[SLYZ022](#) — *TI Glossary*.

This glossary lists and explains terms, acronyms, and definitions.

12 Mechanical, Packaging, and Orderable Information

The following pages include mechanical, packaging, and orderable information. This information is the most current data available for the designated devices. This data is subject to change without notice and revision of this document. For browser-based versions of this data sheet, refer to the left-hand navigation.

PACKAGING INFORMATION

Orderable Device	Status (1)	Package Type	Package Drawing	Pins	Package Qty	Eco Plan (2)	Lead/Ball Finish (6)	MSL Peak Temp (3)	Op Temp (°C)	Device Marking (4/5)	Samples
TPS66120YBGR	ACTIVE	DSBGA	YBG	28	3000	Green (RoHS & no Sb/Br)	SNAGCU	Level-1-260C-UNLIM	-10 to 85	TPS66120	Samples
TPS66121YBGR	ACTIVE	DSBGA	YBG	28	3000	Green (RoHS & no Sb/Br)	SNAGCU	Level-1-260C-UNLIM	-10 to 85	TPS66121	Samples

(1) The marketing status values are defined as follows:

ACTIVE: Product device recommended for new designs.

LIFEBUY: TI has announced that the device will be discontinued, and a lifetime-buy period is in effect.

NRND: Not recommended for new designs. Device is in production to support existing customers, but TI does not recommend using this part in a new design.

PREVIEW: Device has been announced but is not in production. Samples may or may not be available.

OBSOLETE: TI has discontinued the production of the device.

(2) **RoHS:** TI defines "RoHS" to mean semiconductor products that are compliant with the current EU RoHS requirements for all 10 RoHS substances, including the requirement that RoHS substance do not exceed 0.1% by weight in homogeneous materials. Where designed to be soldered at high temperatures, "RoHS" products are suitable for use in specified lead-free processes. TI may reference these types of products as "Pb-Free".

RoHS Exempt: TI defines "RoHS Exempt" to mean products that contain lead but are compliant with EU RoHS pursuant to a specific EU RoHS exemption.

Green: TI defines "Green" to mean the content of Chlorine (Cl) and Bromine (Br) based flame retardants meet JS709B low halogen requirements of <=1000ppm threshold. Antimony trioxide based flame retardants must also meet the <=1000ppm threshold requirement.

(3) MSL, Peak Temp. - The Moisture Sensitivity Level rating according to the JEDEC industry standard classifications, and peak solder temperature.

(4) There may be additional marking, which relates to the logo, the lot trace code information, or the environmental category on the device.

(5) Multiple Device Markings will be inside parentheses. Only one Device Marking contained in parentheses and separated by a "~" will appear on a device. If a line is indented then it is a continuation of the previous line and the two combined represent the entire Device Marking for that device.

(6) Lead/Ball Finish - Orderable Devices may have multiple material finish options. Finish options are separated by a vertical ruled line. Lead/Ball Finish values may wrap to two lines if the finish value exceeds the maximum column width.

Important Information and Disclaimer:The information provided on this page represents TI's knowledge and belief as of the date that it is provided. TI bases its knowledge and belief on information provided by third parties, and makes no representation or warranty as to the accuracy of such information. Efforts are underway to better integrate information from third parties. TI has taken and continues to take reasonable steps to provide representative and accurate information but may not have conducted destructive testing or chemical analysis on incoming materials and chemicals. TI and TI suppliers consider certain information to be proprietary, and thus CAS numbers and other limited information may not be available for release.

In no event shall TI's liability arising out of such information exceed the total purchase price of the TI part(s) at issue in this document sold by TI to Customer on an annual basis.

TAPE AND REEL INFORMATION

QUADRANT ASSIGNMENTS FOR PIN 1 ORIENTATION IN TAPE

*All dimensions are nominal

Device	Package Type	Package Drawing	Pins	SPQ	Reel Diameter (mm)	Reel Width W1 (mm)	A0 (mm)	B0 (mm)	K0 (mm)	P1 (mm)	W (mm)	Pin1 Quadrant
TPS66120YBGR	DSBGA	YBG	28	3000	330.0	12.4	1.78	2.98	0.7	4.0	12.0	Q1
TPS66120YBGR	DSBGA	YBG	28	3000	330.0	12.4	1.78	2.98	0.6	4.0	12.0	Q1
TPS66121YBGR	DSBGA	YBG	28	3000	330.0	12.4	1.78	2.98	0.7	4.0	12.0	Q1
TPS66121YBGR	DSBGA	YBG	28	3000	330.0	12.4	1.78	2.98	0.6	4.0	12.0	Q1

TAPE AND REEL BOX DIMENSIONS

*All dimensions are nominal

Device	Package Type	Package Drawing	Pins	SPQ	Length (mm)	Width (mm)	Height (mm)
TPS66120YBGR	DSBGA	YBG	28	3000	367.0	367.0	35.0
TPS66120YBGR	DSBGA	YBG	28	3000	335.0	335.0	25.0
TPS66121YBGR	DSBGA	YBG	28	3000	367.0	367.0	35.0
TPS66121YBGR	DSBGA	YBG	28	3000	335.0	335.0	25.0

YBG0028

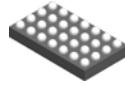

PACKAGE OUTLINE

DSBGA - 0.5 mm max height

DIE SIZE BALL GRID ARRAY

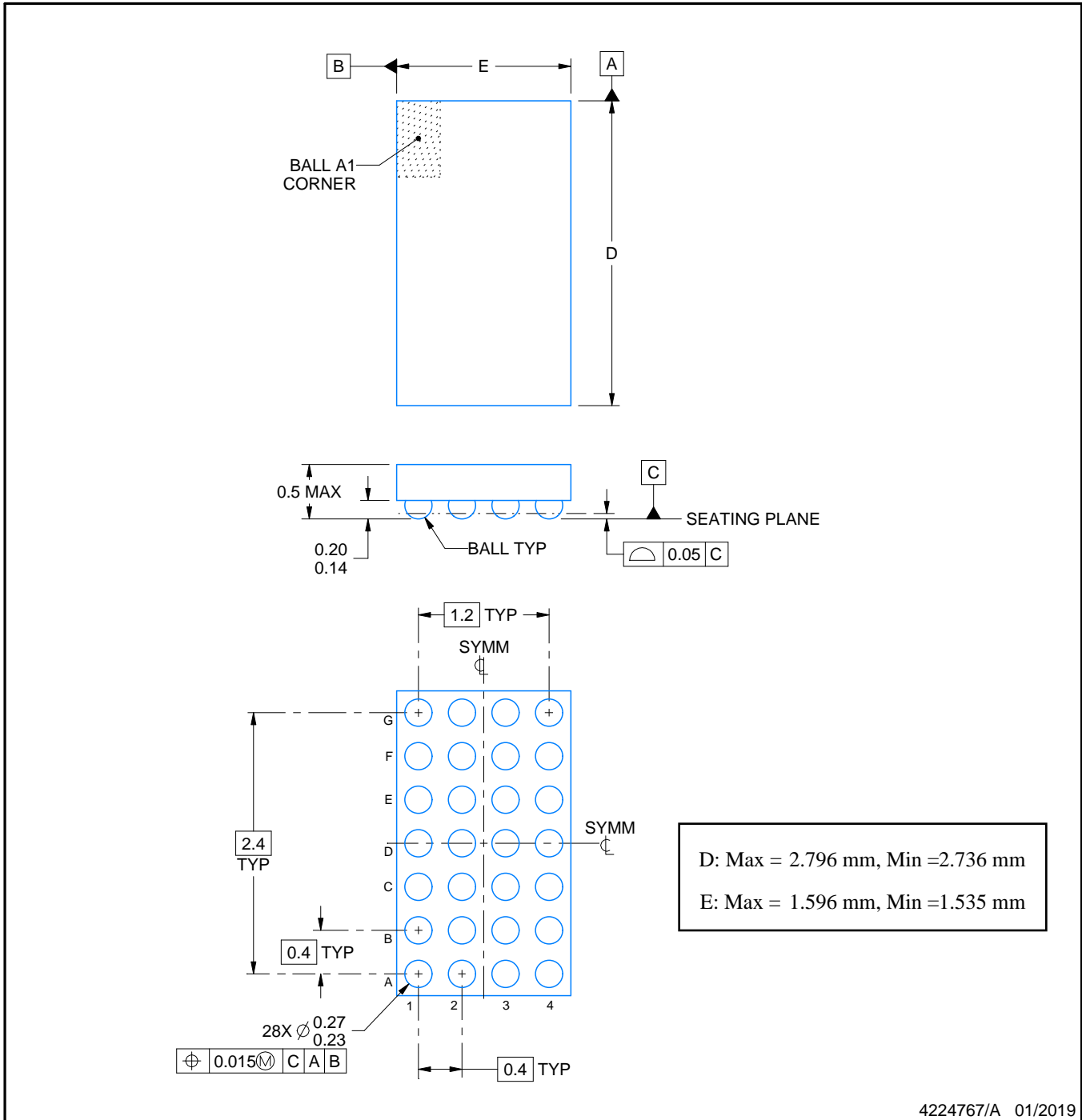

NOTES:

1. All linear dimensions are in millimeters. Any dimensions in parenthesis are for reference only. Dimensioning and tolerancing per ASME Y14.5M.
2. This drawing is subject to change without notice.

EXAMPLE BOARD LAYOUT

YBG0028

DSBGA - 0.5 mm max height

DIE SIZE BALL GRID ARRAY

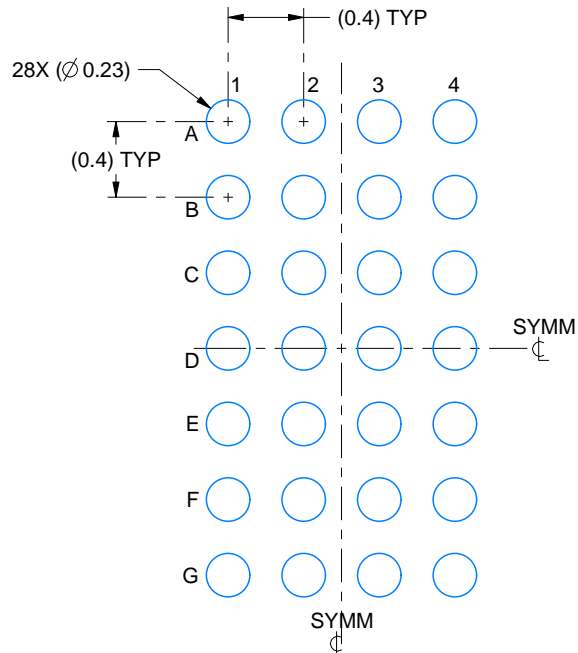

LAND PATTERN EXAMPLE
EXPOSED METAL SHOWN
SCALE: 25X

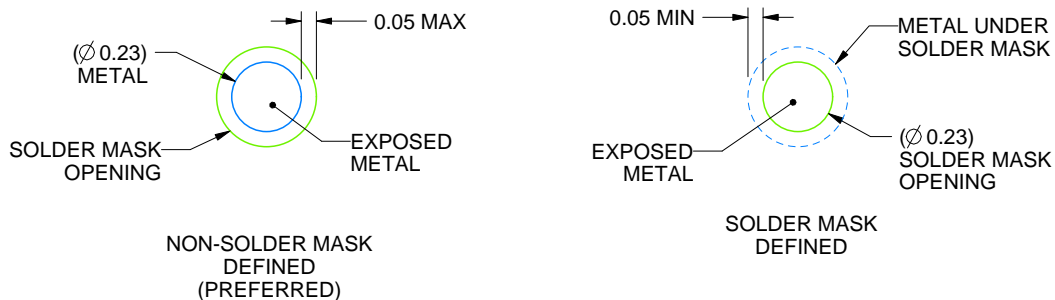

SOLDER MASK DETAILS
NOT TO SCALE

4224767/A 01/2019

NOTES: (continued)

- Final dimensions may vary due to manufacturing tolerance considerations and also routing constraints. See Texas Instruments Literature No. SNVA009 (www.ti.com/lit/snva009).

EXAMPLE STENCIL DESIGN

YBG0028

DSBGA - 0.5 mm max height

DIE SIZE BALL GRID ARRAY

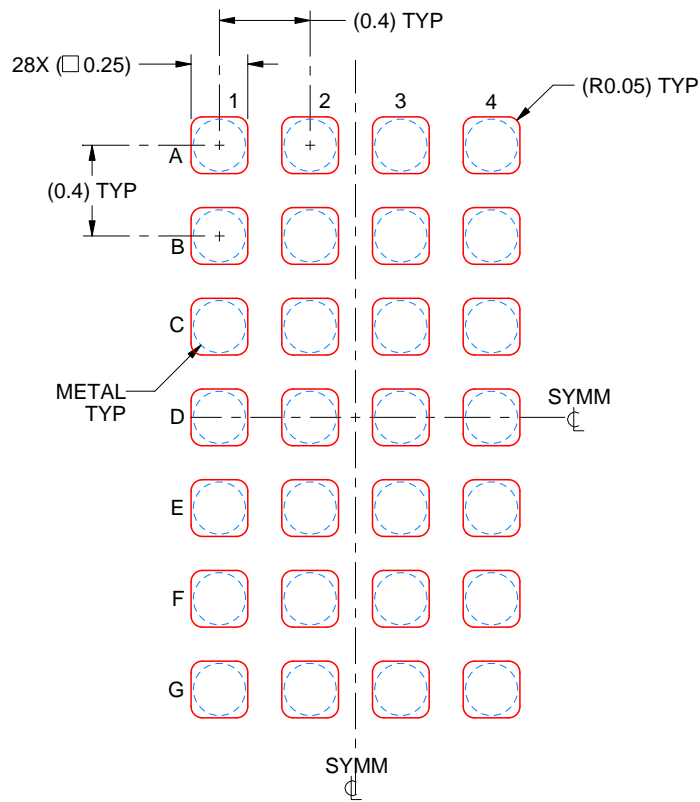

SOLDER PASTE EXAMPLE
BASED ON 0.1 mm THICK STENCIL
SCALE: 30X

4224767/A 01/2019

NOTES: (continued)

4. Laser cutting apertures with trapezoidal walls and rounded corners may offer better paste release.

IMPORTANT NOTICE AND DISCLAIMER

TI PROVIDES TECHNICAL AND RELIABILITY DATA (INCLUDING DATASHEETS), DESIGN RESOURCES (INCLUDING REFERENCE DESIGNS), APPLICATION OR OTHER DESIGN ADVICE, WEB TOOLS, SAFETY INFORMATION, AND OTHER RESOURCES "AS IS" AND WITH ALL FAULTS, AND DISCLAIMS ALL WARRANTIES, EXPRESS AND IMPLIED, INCLUDING WITHOUT LIMITATION ANY IMPLIED WARRANTIES OF MERCHANTABILITY, FITNESS FOR A PARTICULAR PURPOSE OR NON-INFRINGEMENT OF THIRD PARTY INTELLECTUAL PROPERTY RIGHTS.

These resources are intended for skilled developers designing with TI products. You are solely responsible for (1) selecting the appropriate TI products for your application, (2) designing, validating and testing your application, and (3) ensuring your application meets applicable standards, and any other safety, security, or other requirements. These resources are subject to change without notice. TI grants you permission to use these resources only for development of an application that uses the TI products described in the resource. Other reproduction and display of these resources is prohibited. No license is granted to any other TI intellectual property right or to any third party intellectual property right. TI disclaims responsibility for, and you will fully indemnify TI and its representatives against, any claims, damages, costs, losses, and liabilities arising out of your use of these resources.

TI's products are provided subject to TI's Terms of Sale (www.ti.com/legal/termsofsale.html) or other applicable terms available either on ti.com or provided in conjunction with such TI products. TI's provision of these resources does not expand or otherwise alter TI's applicable warranties or warranty disclaimers for TI products.

Mailing Address: Texas Instruments, Post Office Box 655303, Dallas, Texas 75265
Copyright © 2020, Texas Instruments Incorporated