

NLAS7222CMUGEVB

NLAS7222C High-Speed USB 2.0 (480 Mbps) DPDT Switch Evaluation Board User's Manual



ON Semiconductor®

<http://onsemi.com>

EVAL BOARD USER'S MANUAL

Introduction

This evaluation board has been designed for a quick evaluation of the NLAS7222C. The NLAS7222C is a 2-to-1 analog switch designed for USB 2.0 signals, as shown in the block diagram in Figure 1 on the right. Among its main characteristics, this evaluation board has been constructed to easily interface with a customer's systems and equipment through USB connectors. The evaluation board can be seen in Figure 2 below.

This manual provides a bill of materials, board schematic, and a layout overview of the evaluation board. The appropriate setup to evaluate the device is also provided.

This document must be used with the NLAS7222C datasheet available on www.onsemi.com. The datasheet contains full technical details about the specifications and operation of the device. When the intention is to evaluate the device considering the specifications given in the datasheet, it is important to take into account the additional circuitry which may include changes in the characteristic impedance matching.

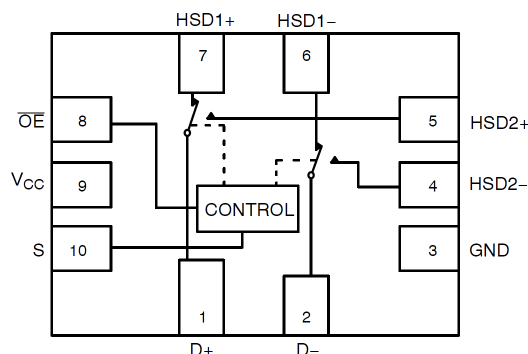

Figure 1. Block Diagram of NCN7222C

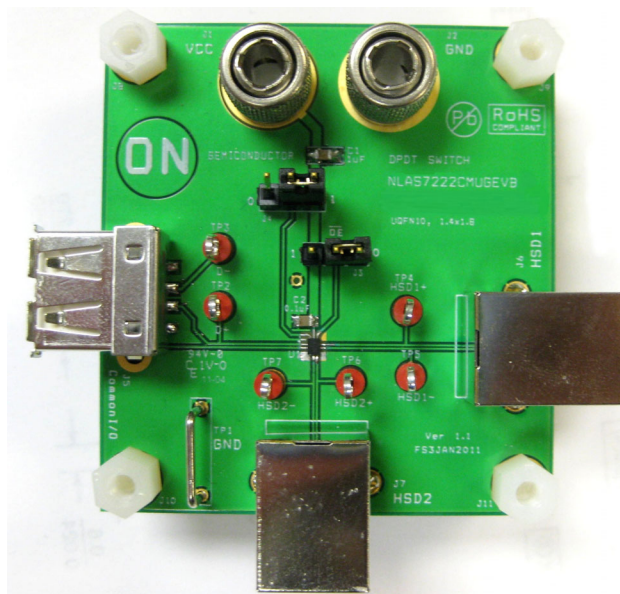

Figure 2. Evaluation Board

NLAS7222CMUGEVB

TEST PROCEDURE

Equipment

- DC Power Supply
- Two Banana Cables
- Computer with USB port
- USB Flash Drive
- USB Cable (Type A to Type B)

Procedure

1. Set the power supply to 3.3 V. Connect the power supply from **VCC** to **GND** using the banana cables. The supply current should be less than 1 μ A.
2. Connect the USB drive to the **Common I/O** USB port.

3. Select the desired output port (**HSD1** or **HSD2**) by moving the jumpers to the appropriate logic level for **S** and $\overline{\text{OE}}$, as shown in the function table in Table 1.
4. Connect the USB cable from the desired output port (**HSD1** or **HSD2**) to the computer's USB port. You will now be able to access the USB drive through the computer.

Table 1. FUNCTION TABLE

$\overline{\text{OE}}$	S	HSD1+, HSD1-	HSD2+, HSD2-
1	X	OFF	OFF
0	0	ON	OFF
0	1	OFF	ON

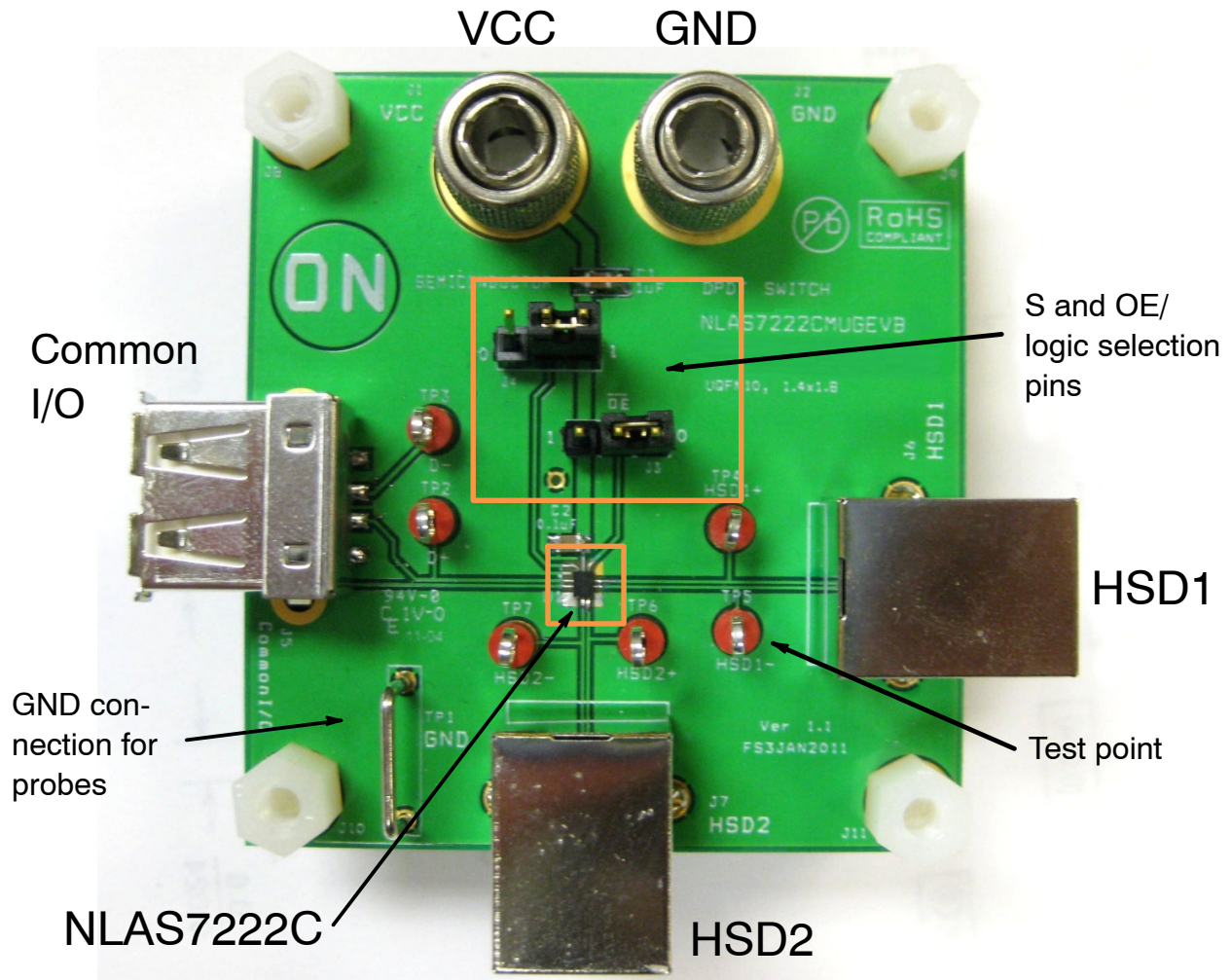

Figure 3. Evaluation Board Close-Up

NLAS7222CMUGEVB

SCHEMATIC

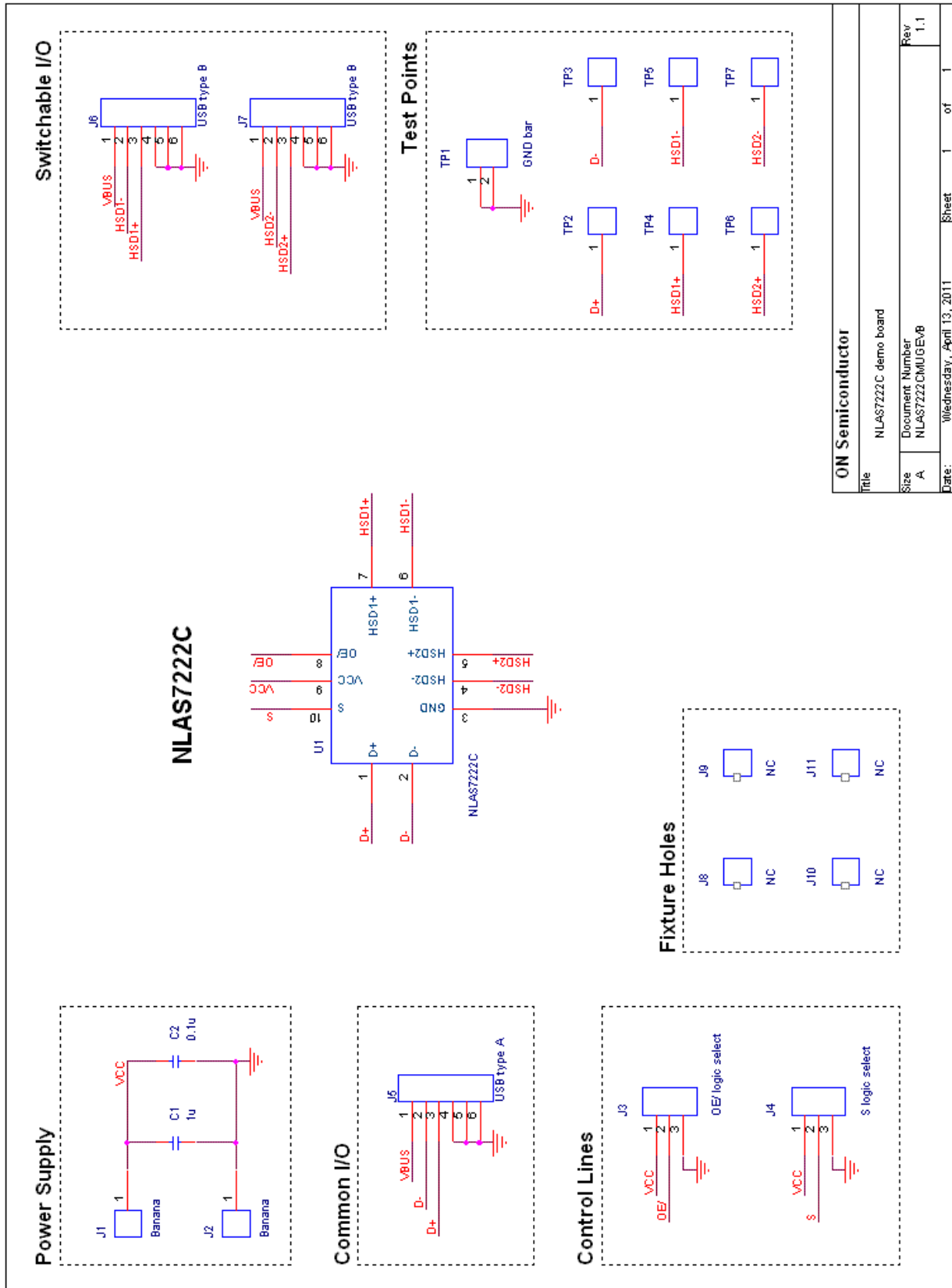

Figure 4. Evaluation Board Schematic

NLA7222CMUGEVB

Table 2. BILL OF MATERIALS

Designator	Qty	Description	Value	Tolerance	Footprint	Manufacturer	Manufacturer Part Number
C1	1	Ceramic Capacitor SMD	1 μ F	10%	0805	AVX	GRM155R60J105
C2	1	Ceramic Capacitor SMD	0.1 μ F	10%	0402	Yageo	CC0402ZRY5V7BB104
J1, J2	2	Banana Connector	n/a	n/a	7 mm Hole	Johnson Components	111-2223-001
J3, J4	2	3-Pin Header	n/a	n/a	Header3	Tyco Electronics	5-826629-0
J3, J4	2	2-Pin Jumper	n/a	n/a	n/a	Tyco Electronics	4-881545-2
J5	1	USB TypeA Connector	n/a	n/a	USB TypeA	Mill-Max	896-43-004-00-000000
J6, J7	2	USB TypeB Connector	n/a	n/a	USB TypeB	Adam Tech	USB-B-S-RA
J8, J9, J10, J11	4	Standoff Nut	n/a	n/a	n/a	Keystone Electronics	1903C
J8, J9, J10, J11	4	Standoff Screw	n/a	n/a	n/a	Keystone Electronics	4814K-ND
TP1	1	PCB Shorting Link	n/a	n/a	n/a	Harwin	D3082-46
TP2, TP3, TP4, TP5, TP6, TP7	6	Test Point PC Multi Purpose	n/a	n/a	1.6mm hole	Keystone Electronics	5010
U1	1	NLA7222C	n/a	n/a	UQFN10	ON Semiconductor	NLA7222CMUTBG

NLAS7222CMUGEVB

PCB LAYOUT

The PCB and components are made of lead-free and RoHS compliant materials. The layout is shown in Figure 5 below. The top layer traces are shown in magenta, and the

bottom layer traces are shown in cyan. Ground pours are present on the top and bottom layers for connectivity. PCB dimensions are 53 mm x 58 mm x 1 mm.

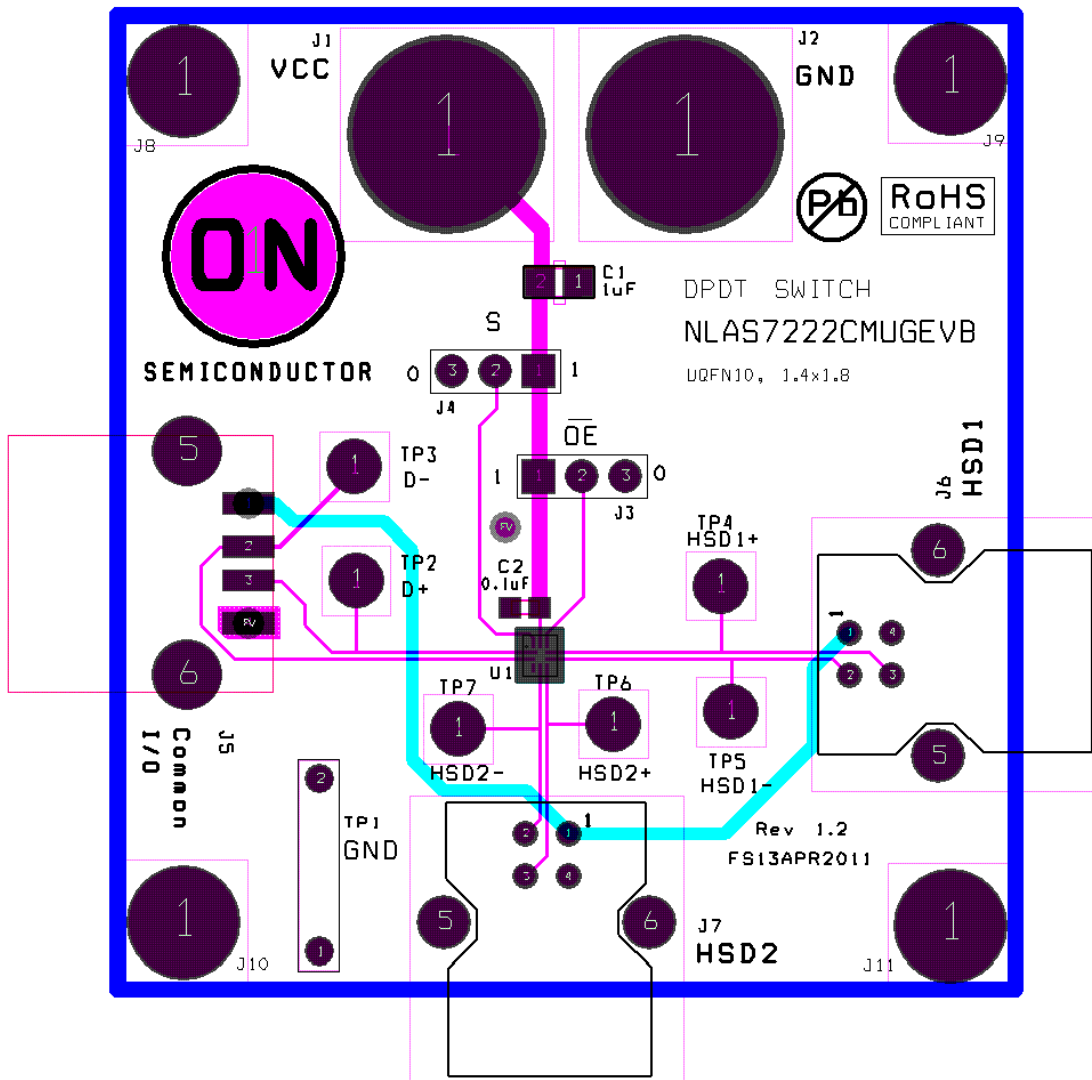

Figure 5. Evaluation Board Layout

PCB LAYOUT GUIDELINES

Implementing a high speed USB switch device requires paying attention on data lines and traces to preserve signal integrity. The demonstration board serves as layout example and can support the design engineers to preserve high speed performances.

Electrical layout guidelines are:

- ◆ The bypass capacitor must be placed as close as possible to the VCC input pin for noise immunity.
- ◆ The characteristics impedance of each switch segment must be 45 Ω.

- ◆ The ground plane of the PCB will be used to determine the characteristics impedance of each line.
- ◆ All corresponding D+/D- line segment pairs must be the same length.
- ◆ The use of vias to route these signals should be avoided when possible.
- ◆ The use of turns or bends to route these signal should be avoided when possible.

ON Semiconductor and the ON Semiconductor logo are trademarks of Semiconductor Components Industries, LLC dba ON Semiconductor or its subsidiaries in the United States and/or other countries. ON Semiconductor owns the rights to a number of patents, trademarks, copyrights, trade secrets, and other intellectual property. A listing of ON Semiconductor's product/patent coverage may be accessed at www.onsemi.com/site/pdf/Patent-Marking.pdf. ON Semiconductor is an Equal Opportunity/Affirmative Action Employer. This literature is subject to all applicable copyright laws and is not for resale in any manner.

The evaluation board/kit (research and development board/kit) (hereinafter the "board") is not a finished product and is as such not available for sale to consumers. The board is only intended for research, development, demonstration and evaluation purposes and should as such only be used in laboratory/development areas by persons with an engineering/technical training and familiar with the risks associated with handling electrical/mechanical components, systems and subsystems. This person assumes full responsibility/liability for proper and safe handling. Any other use, resale or redistribution for any other purpose is strictly prohibited.

The board is delivered "AS IS" and without warranty of any kind including, but not limited to, that the board is production-worthy, that the functions contained in the board will meet your requirements, or that the operation of the board will be uninterrupted or error free. ON Semiconductor expressly disclaims all warranties, express, implied or otherwise, including without limitation, warranties of fitness for a particular purpose and non-infringement of intellectual property rights.

ON Semiconductor reserves the right to make changes without further notice to any board.

You are responsible for determining whether the board will be suitable for your intended use or application or will achieve your intended results. Prior to using or distributing any systems that have been evaluated, designed or tested using the board, you agree to test and validate your design to confirm the functionality for your application. Any technical, applications or design information or advice, quality characterization, reliability data or other services provided by ON Semiconductor shall not constitute any representation or warranty by ON Semiconductor, and no additional obligations or liabilities shall arise from ON Semiconductor having provided such information or services.

The boards are not designed, intended, or authorized for use in life support systems, or any FDA Class 3 medical devices or medical devices with a similar or equivalent classification in a foreign jurisdiction, or any devices intended for implantation in the human body. Should you purchase or use the board for any such unintended or unauthorized application, you shall indemnify and hold ON Semiconductor and its officers, employees, subsidiaries, affiliates, and distributors harmless against all claims, costs, damages, and expenses, and reasonable attorney fees arising out of, directly or indirectly, any claim of personal injury or death associated with such unintended or unauthorized use, even if such claim alleges that ON Semiconductor was negligent regarding the design or manufacture of the board.

This evaluation board/kit does not fall within the scope of the European Union directives regarding electromagnetic compatibility, restricted substances (RoHS), recycling (WEEE), FCC, CE or UL, and may not meet the technical requirements of these or other related directives.

FCC WARNING – This evaluation board/kit is intended for use for engineering development, demonstration, or evaluation purposes only and is not considered by ON Semiconductor to be a finished end product fit for general consumer use. It may generate, use, or radiate radio frequency energy and has not been tested for compliance with the limits of computing devices pursuant to part 15 of FCC rules, which are designed to provide reasonable protection against radio frequency interference. Operation of this equipment may cause interference with radio communications, in which case the user shall be responsible, at its expense, to take whatever measures may be required to correct this interference.

ON Semiconductor does not convey any license under its patent rights nor the rights of others.

LIMITATIONS OF LIABILITY: ON Semiconductor shall not be liable for any special, consequential, incidental, indirect or punitive damages, including, but not limited to the costs of requalification, delay, loss of profits or goodwill, arising out of or in connection with the board, even if ON Semiconductor is advised of the possibility of such damages. In no event shall ON Semiconductor's aggregate liability from any obligation arising out of or in connection with the board, under any theory of liability, exceed the purchase price paid for the board, if any.

For more information and documentation, please visit www.onsemi.com.

PUBLICATION ORDERING INFORMATION

LITERATURE FULFILLMENT:

Email Requests to: orderlit@onsemi.com

ON Semiconductor Website: www.onsemi.com

TECHNICAL SUPPORT

North American Technical Support:

Voice Mail: 1 800-282-9855 Toll Free USA/Canada

Phone: 011 421 33 790 2910

Europe, Middle East and Africa Technical Support:

Phone: 00421 33 790 2910

For additional information, please contact your local Sales Representative