

DS280DF810 28 Gbps Multi-Rate 8-Channel Retimer

1 Features

- Octal-Channel Multi-Rate Retimer with Integrated Signal Conditioning
- All Channels Lock Independently from 20.2 Gbps to 28.4 Gbps (Including Sub-Rates Like 10.1376 Gbps, 10.3125 Gbps, 12.5 Gbps, and More)
- Ultra-Low Latency: <500 ps typical for 28.4 Gbps data rate
- Single Power Supply, No Low-Jitter Reference Clock Required, and Integrated AC Coupling Capacitors to Reduce Board Routing Complexity and BOM Cost
- Integrated 2x2 Cross Point
- Adaptive Continuous Time Linear Equalizer (CTLE)
- Adaptive Decision Feedback Equalizer (DFE)
- Low-Jitter Transmitter with 3-Tap FIR Filter
- Combined Equalization Supporting 35+ dB Channel Loss at 12.9 GHz; 30+ dB Channel Loss at 14 GHz
- Adjustable Transmit Amplitude: 205 mVppd to 1225 mVppd (typical)
- On-Chip Eye Opening Monitor (EOM), PRBS Pattern Checker/Generator
- Small 8 mm x 13 mm BGA Package with Easy Flow-Through Routing
- Unique Pinout Allows Routing High-Speed Signals Underneath the Package
- Pin-Compatible Repeater Available
- Extended Temperature Range: -40 °C to 85 °C

2 Applications

- [Backplane and Mid-plane Reach Extension](#)
- Jitter Cleaning for Front-Port Optical
- IEEE802.3bj 100GbE, Infiniband EDR, and OIF-CEI-25G-LR/MR/SR/VSR Electrical Interfaces
- SFP28, QSFP28, CFP2/CFP4, CDFP

3 Description

The DS280DF810 is an eight-channel multi-rate Retimer with integrated signal conditioning. It is used to extend the reach and robustness of long, lossy, crosstalk-impaired high-speed serial links while achieving a bit error rate (BER) of 10^{-15} or less.

Each channel of the DS280DF810 independently locks to serial data rates in a continuous range from 20.2 Gbps to 28.4 Gbps or to any supported sub-rate ($\div 2$ and $\div 4$), including key data rates such as 10.1376 Gbps, 10.3125 Gbps, and 12.5 Gbps, which allows the DS280DF810 to support individual lane Forward Error Correction (FEC) pass-through.

Device Information(1)

PART NUMBER	PACKAGE	BODY SIZE (NOM)
DS280DF810	135-pin fcBGA (135)	8.0 mm x 13.0 mm

(1) For all available packages, see the orderable addendum at the end of the data sheet.

Simplified Schematic

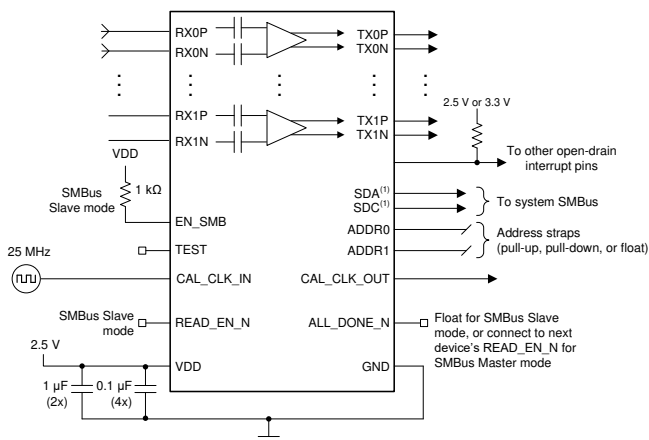

(1) SMBus signals need to be pulled up elsewhere in the system.



Table of Contents

1 Features	1	8 Detailed Description	16
2 Applications	1	8.1 Overview	16
3 Description	1	8.2 Functional Block Diagram	17
4 Revision History	2	8.3 Feature Description	18
5 Description (continued)	3	8.4 Device Functional Modes	29
6 Pin Configuration and Functions	4	8.5 Programming	30
7 Specifications	7	8.6 Register Maps	31
7.1 Absolute Maximum Ratings	7	9 Application and Implementation	32
7.2 ESD Ratings	7	9.1 Application Information	32
7.3 Recommended Operating Conditions	8	9.2 Typical Application	32
7.4 Thermal Information	8	10 Power Supply Recommendations	41
7.5 Electrical Characteristics	8	11 Layout	41
7.6 Timing Requirements, Retimer Jitter Specifications	12	11.1 Layout Guidelines	41
7.7 Timing Requirements, Retimer Specifications	13	11.2 Layout Example	41
7.8 Timing Requirements, Recommended Calibration Clock Specifications	14	12 Device and Documentation Support	43
7.9 Recommended SMBus Switching Characteristics (Slave Mode)	14	12.1 Documentation Support	43
7.10 Recommended SMBus Switching Characteristics (Master Mode)	14	12.2 Receiving Notification of Documentation Updates	43
7.11 Typical Characteristics	15	12.3 Support Resources	43
		12.4 Trademarks	43
		12.5 Electrostatic Discharge Caution	43
		12.6 Glossary	43

4 Revision History

Changes from Original (February 2019) to Revision A

Page

• Initial Public Release	1
--------------------------------	----------

5 Description (continued)

Integrated physical AC coupling capacitors (TX and RX) eliminate the need for external capacitors on the PCB. The DS280DF810 has a single power supply and minimal need for external components. These features reduce PCB routing complexity and BOM cost.

The advanced equalization features of the DS280DF810 include a low-jitter 3-tap transmit finite impulse response (FIR) filter, an adaptive continuous-time linear equalizer (CTLE), and an adaptive decision feedback equalizer (DFE). This enables reach extension for lossy interconnect and backplanes with multiple connectors and crosstalk. The integrated CDR function is ideal for front-port optical module applications to reset the jitter budget and retimer the high-speed serial data. The DS280DF810 implements 2x2 cross-point on each channel pair, providing the host with both lane crossing and fanout options.

The DS280DF810 can be configured either via the SMBus or through an external EEPROM. Up to 16 devices can share a single EEPROM. A non-disruptive on-chip eye monitor and a PRBS generator and checker allow for in-system diagnostics.

6 Pin Configuration and Functions

135-pin fcBGA, 0.8 mm BGA pin pitch
Top View

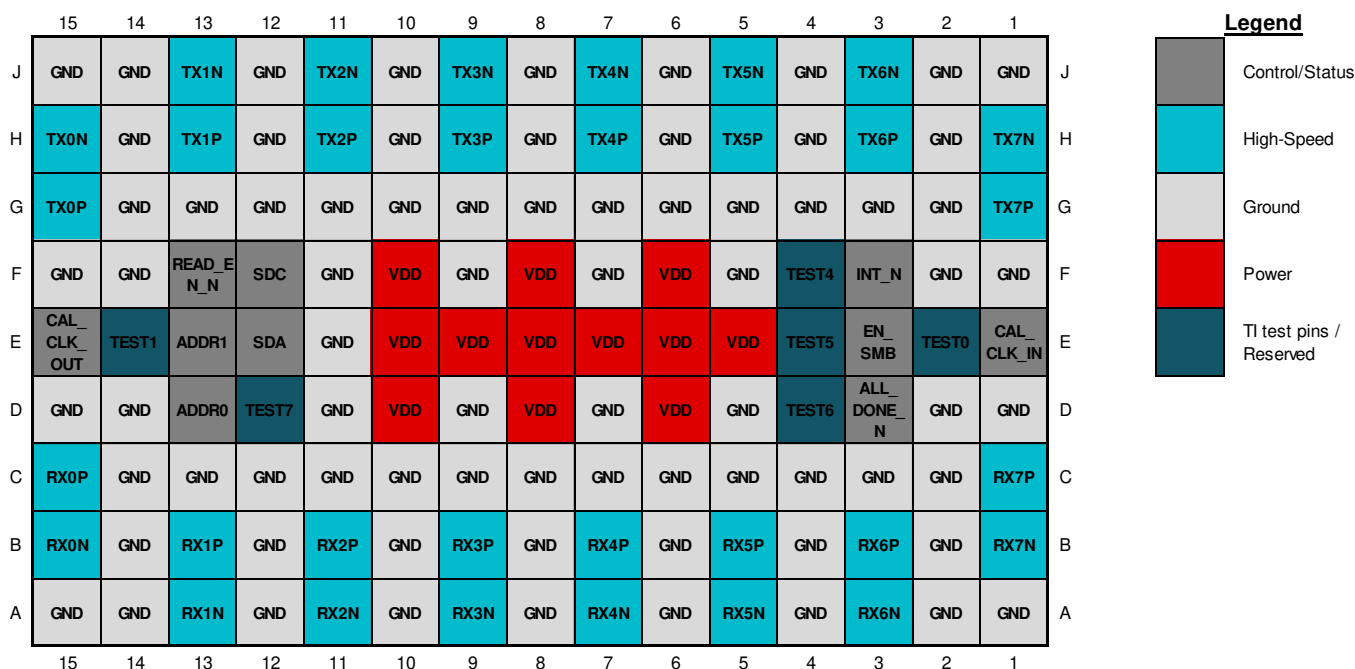

Pin Functions

PIN		TYPE	INTERNAL PULL-UP/ PULL-DOWN	DESCRIPTION
NAME	NO.			
HIGH SPEED DIFFERENTIAL I/Os				
RX0P	C15	Input	None	Inverting and non-inverting differential inputs to the equalizer. An on-chip 100-Ω termination resistor connects RXP to RXN. These inputs are AC coupled on-chip with physical 220 nF capacitors.
RX0N	B15	Input	None	
RX1P	B13	Input	None	Inverting and non-inverting differential inputs to the equalizer. An on-chip 100-Ω termination resistor connects RXP to RXN. These inputs are AC coupled on-chip with physical 220 nF capacitors.
RX1N	A13	Input	None	
RX2P	B11	Input	None	Inverting and non-inverting differential inputs to the equalizer. An on-chip 100-Ω termination resistor connects RXP to RXN. These inputs are AC coupled on-chip with physical 220 nF capacitors.
RX2N	A11	Input	None	
RX3P	B9	Input	None	Inverting and non-inverting differential inputs to the equalizer. An on-chip 100-Ω termination resistor connects RXP to RXN. These inputs are AC coupled on-chip with physical 220 nF capacitors.
RX3N	A9	Input	None	
RX4P	B7	Input	None	Inverting and non-inverting differential inputs to the equalizer. An on-chip 100-Ω termination resistor connects RXP to RXN. These inputs are AC coupled on-chip with physical 220 nF capacitors.
RX4N	A7	Input	None	
RX5P	B5	Input	None	Inverting and non-inverting differential inputs to the equalizer. An on-chip 100-Ω termination resistor connects RXP to RXN. These inputs are AC coupled on-chip with physical 220 nF capacitors.
RX5N	A5	Input	None	
RX6P	B3	Input	None	Inverting and non-inverting differential inputs to the equalizer. An on-chip 100-Ω termination resistor connects RXP to RXN. These inputs are AC coupled on-chip with physical 220 nF capacitors.
RX6N	A3	Input	None	
RX7P	C1	Input	None	Inverting and non-inverting differential inputs to the equalizer. An on-chip 100-Ω termination resistor connects RXP to RXN. These inputs are AC coupled on-chip with physical 220 nF capacitors.
RX7N	B1	Input	None	
TX0P	G15	Output	None	Inverting and non-inverting 50 Ω driver outputs. These outputs are AC coupled on-chip with physical 220 nF capacitors.
TX0N	H15	Output	None	

Pin Functions (continued)

PIN		TYPE	INTERNAL PULL-UP/ PULL-DOWN	DESCRIPTION
NAME	NO.			
TX1P	H13	Output	None	Inverting and non-inverting 50 Ω driver outputs. These outputs are AC coupled on-chip with physical 220 nF capacitors.
TX1N	J13	Output	None	
TX2P	H11	Output	None	Inverting and non-inverting 50 Ω driver outputs. These outputs are AC coupled on-chip with physical 220 nF capacitors.
TX2N	J11	Output	None	
TX3P	H9	Output	None	Inverting and non-inverting 50 Ω driver outputs. These outputs are AC coupled on-chip with physical 220 nF capacitors.
TX3N	J9	Output	None	
TX4P	H7	Output	None	Inverting and non-inverting 50 Ω driver outputs. These outputs are AC coupled on-chip with physical 220 nF capacitors.
TX4N	J7	Output	None	
TX5P	H5	Output	None	Inverting and non-inverting 50 Ω driver outputs. These outputs are AC coupled on-chip with physical 220 nF capacitors.
TX5N	J5	Output	None	
TX6P	H3	Output	None	Inverting and non-inverting 50 Ω driver outputs. These outputs are AC coupled on-chip with physical 220 nF capacitors.
TX6N	J3	Output	None	
TX7P	G1	Output	None	Inverting and non-inverting 50 Ω driver outputs. These outputs are AC coupled on-chip with physical 220 nF capacitors.
TX7N	H1	Output	None	
CALIBRATION CLOCK PINS				
CAL_CLK_IN	E1	Input, 2.5 V CMOS	Weak pull-down	25 MHz (±100 PPM) 2.5 V single-ended clock from external oscillator. No stringent phase noise or jitter requirements on this clock. Used to calibrate VCO frequency range. This clock is not used to recover data.
CAL_CLK_OUT	E15	Output, 2.5 V CMOS	None	2.5 V buffered replica of calibration clock input (pin E1) for connecting multiple devices in a daisy-chained fashion.
SYSTEM MANAGEMENT BUS (SMBUS) PINS				
ADDR0	D13	Input, 4-level	None	4-level strap pins used to set the SMBus address of the device. The pin state is read on power-up. The multi-level nature of these pins allows for 16 unique device addresses. The four strap options include: 0: 1 kΩ to GND R: 10 kΩ to GND F: Float 1: 1 kΩ to VDD Refer to Device SMBus Address for more information.
ADDR1	E13	Input, 4-level	None	
EN_SMB	E3	Input, 4-level	None	Four-level 2.5 V input used to select between SMBus master mode (float) and SMBus slave mode (high). The four defined levels are: 0: 1 kΩ to GND - RESERVED, T1 test mode. R: 10 kΩ to GND - RESERVED, T1 test mode F: Float - SMBus Master Mode 1: 1 kΩ to VDD - SMBus Slave Mode
SDA	E12	I/O, 3.3 V LVCMOS, Open Drain	None	SMBus data input and open drain output. External 2 kΩ to 5 kΩ pull-up resistor is required as per SMBus interface standard. This pin is 3.3 V LVCMOS tolerant.
SDC	F12	I/O, 3.3 V LVCMOS, Open Drain	None	SMBus clock input and open drain clock output. External 2 kΩ to 5 kΩ pull-up resistor is required as per SMBus interface standard. This pin is 3.3 V LVCMOS tolerant.

Pin Functions (continued)

PIN		TYPE	INTERNAL PULL-UP/ PULL-DOWN	DESCRIPTION
NAME	NO.			
SMBUS MASTER MODE PINS				
READ_EN_N	F13	Input, 3.3 V LVC MOS	Weak pull-up	SMBus Master Mode (EN_SMB=Float): When asserted low, initiates the SMBus master mode EEPROM read function. Once EEPROM read is complete (indicated by assertion of ALL_DONE_N low), this pin can be held low for normal device operation. This pin is 3.3 V tolerant. SMBus Slave Mode (EN_SMB=1): When asserted low, this causes the device to be held in reset (I ² C state machine reset and register reset). This pin should be pulled high or left floating for normal operation in SMBus Slave Mode. This pin is 3.3 V tolerant.
ALL_DONE_N	D3	Output, LVC MOS	None	Indicates the completion of a valid EEPROM register load operation when in SMBus Master Mode (EN_SMB=Float): High = External EEPROM load failed or incomplete Low = External EEPROM load successful and complete When in SMBus slave mode (EN_SMB=1), this output reflects the status of READ_EN_N input..
MISCELLANEOUS PINS				
INT_N	F3	Output, LVC MOS, Open-Drain	None	Open-drain 3.3 V tolerant active-low interrupt output. It pulls low when an interrupt occurs. The events which trigger an interrupt are programmable through SMBus registers. This pin can be connected in a wired-OR fashion with other device's interrupt pin. A single pull-up resistor in the 2 kΩ to 5 kΩ range is adequate for the entire INT_N net.
TEST0	E2	Input, LVC MOS	Weak pull-up	Reserved TI test pins. During normal (non-test-mode) operation, these pins are configured as inputs and therefore they are not affected by the presence of a signal. These pins may be left floating, tied to GND, or connected to a 2.5-V (max) output.
TEST1	E14	Input, LVC MOS	Weak pull-up	
TEST4	F4	Input, LVC MOS	Weak pull-up	
TEST5	E4	Input, LVC MOS	Weak pull-up	
TEST6	D4	Input, LVC MOS	Weak pull-up	
TEST7	D12	Input, LVC MOS	Weak pull-up	
TEST7	D12	Input, LVC MOS	Weak pull-up	
POWER				
VDD	D6, D8, D10, E5, E6, E7, E8, E9, E10, F6, F8, F10	Power	None	Power supply, VDD = 2.5 V ±5%. TI recommends connecting at least six de-coupling capacitors between the Retimer's VDD plane and GND as close to the Retimer as possible. For example, four 0.1 μF capacitors and two 1 μF capacitors directly beneath the device or as close to the VDD pins as possible. The VDD pins on this device should be connected through a low-resistance path to the board VDD plane.

Pin Functions (continued)

PIN		TYPE	INTERNAL PULL-UP/ PULL-DOWN	DESCRIPTION
NAME	NO.			
GND	A1, A2, A4, A6, A8, A10, A12, A14, A15, B2, B4, B6, B8, B10, B12, B14, C2, C3, C4, C5, C6, C7, C8, C9, C10, C11, C12, C13, C14, D1, D2, D5, D7, D9, D11, D14, D15, E11, F1, F2, F5, F7, F9, F11, F14, F15, G2, G3, G4, G5, G6, G7, G8, G9, G10, G11, G12, G13, G14, H2, H4, H6, H8, H10, H12, H14, J1, J2, J4, J6, J8, J10, J12, J14, J15	Power	None	Ground reference. The GND pins on this device should be connected through a low-resistance path to the board GND plane.

7 Specifications

7.1 Absolute Maximum Ratings

Over operating free-air temperature range (unless otherwise noted). ⁽¹⁾

		MIN	MAX	UNIT
VDD _{ABSMAX}	Supply voltage (VDD)	-0.5	2.75	V
VIO _{2.5V,ABSMAX}	2.5 V I/O voltage (LVCMOS, CMOS and Analog)	-0.5	2.75	V
VIO _{3.3V,ABSMAX}	Open Drain Voltage (SDA, SDC, INT_N) and LVCMOS Input Voltage (READ_EN_N)	-0.5	4.0	V
VIN _{ABSMAX}	Signal input voltage (RXnP, RXnN)	-0.5	2.75	V
VOU _{ABSMAX}	Signal output voltage (TXnP, TXnN)	-0.5	2.75	V
TJ _{ABSMAX}	Junction temperature		150	°C
Tstg	Storage temperature	-40	150	°C

- (1) Stresses beyond those listed under *Absolute Maximum Ratings* may cause permanent damage to the device. These are stress ratings only, which do not imply functional operation of the device at these or any other conditions beyond those indicated under *Recommended Operating Conditions*. Exposure to absolute-maximum-rated conditions for extended periods may affect device reliability.

7.2 ESD Ratings

		VALUE	UNIT	
V _(ESD)	Electrostatic discharge	Human-body model (HBM), per ANSI/ESDA/JEDEC JS-001 ⁽¹⁾	±2,000	V
		Charged-device model (CDM), per JEDEC specification JESD22-C101 ⁽²⁾	±1,000	V

- (1) JEDEC document JEP155 states that 500-V HBM allows safe manufacturing with a standard ESD control process. Manufacturing with less than 500-V HBM is possible with the necessary precautions. Pins listed as ±2,000 V may actually have higher performance.
- (2) JEDEC document JEP157 states that 250-V CDM allows safe manufacturing with a standard ESD control process. Manufacturing with less than 250-V CDM is possible with the necessary precautions. Pins listed as ±1,000 V may actually have higher performance.

7.3 Recommended Operating Conditions

Over operating free-air temperature range (unless otherwise noted).

		MIN	MAX	UNIT
VDD	Supply voltage, VDD to GND. DC plus AC power should not exceed these limits.	2.375	2.625	V
NVDD	Supply noise, DC to < 50 Hz, sinusoidal ⁽¹⁾		250	mVpp
NVDD	Supply noise, 50 Hz to 10 MHz, sinusoidal ⁽¹⁾		20	mVpp
NVDD	Supply noise, >10 MHz, sinusoidal ⁽¹⁾		10	mVpp
T _{rampVDD}	VDD supply ramp time, from 0 V to 2.375 V	150		μs
T _J	Operating junction temperature	-40	110	°C
T _A	Operating ambient temperature	-40	85 ⁽²⁾	°C
VIO _{2.5V}	2.5 V I/O voltage (LVCMOS, CMOS and Analog)	2.375	2.625	V
VIO _{3.3V,INT_N}	Open Drain LVCMOS I/O voltage (INT_N)		3.6	V
VIO _{3.3V}	Open Drain LVCMOS I/O voltage (SDA, SDC)	2.375	3.6	V

- (1) Steps must be taken to ensure the combined AC plus DC supply noise meets the specified VDD supply voltage limits.
 (2) Steps must be taken to ensure the operating junction temperature range and ambient temperature stay-in-lock range (TEMP_{LOCK+}, TEMP_{LOCK-}) are met. Refer to [Timing Requirements](#), [Retimer Jitter Specifications](#) for more details concerning TEMP_{LOCK+} and TEMP_{LOCK-}.

7.4 Thermal Information

THERMAL METRIC ⁽¹⁾	CONDITIONS/ASSUMPTIONS ⁽²⁾	DS280DF810	UNIT
		FC/CSP (ABV)	
		135 PINS	
R _{θJA} Junction-to-ambient thermal resistance	4-Layer JEDEC Board	26.4	°C/W
	10-Layer 8-in x 6-in Board	9.3	
	20-Layer 8-in x 6-in Board	8.5	
	30-Layer 8-in x 6-in Board	8.2	
R _{θJC(top)} Junction-to-case (top) thermal resistance	4-Layer JEDEC Board	1.6	°C/W
R _{θJB} Junction-to-board thermal resistance	4-Layer JEDEC Board	9.3	°C/W
Ψ _{JT} Junction-to-top characterization parameter	4-Layer JEDEC Board	0.1	°C/W
	10-Layer 8-in x 6-in Board	0.1	
	20-Layer 8-in x 6-in Board	0.1	
	30-Layer 8-in x 6-in Board	0.1	
Ψ _{JB} Junction-to-board characterization parameter	4-Layer JEDEC Board	9.3	°C/W
	10-Layer 8-in x 6-in Board	5.0	
	20-Layer 8-in x 6-in Board	4.9	
	30-Layer 8-in x 6-in Board	4.6	

- (1) For more information about traditional and new thermal metrics, see the *Semiconductor and IC Package Thermal Metrics* application report, [SPRA953](#).
 (2) No heat sink or airflow was assumed for these estimations. Depending on the application, a heat sink, faster airflow, or reduced ambient temperature (<85 C) may be required in order to meet the maximum junction temperature specification per the [Recommended Operating Conditions](#).

7.5 Electrical Characteristics

Over operating free-air temperature range (unless otherwise noted).

PARAMETER		TEST CONDITIONS	MIN	TYP	MAX	UNIT
Rbaud	Input data rate	Full-rate	20.2		28.4	Gbps
		Half-rate	10.1		14.2	Gbps
		Quarter-rate	5.05		7.1	Gbps

Electrical Characteristics (continued)

Over operating free-air temperature range (unless otherwise noted).

PARAMETER		TEST CONDITIONS	MIN	TYP	MAX	UNIT
t_{EEPROM}	EEPROM configuration load time	Single device reading its configuration from an EEPROM. Common channel configuration. This time scales with the number of devices reading from the same EEPROM.			15 ⁽¹⁾	ms
t_{EEPROM}	EEPROM configuration load time	Single device reading its configuration from an EEPROM. Unique channel configuration. This time scales with the number of devices reading from the same EEPROM.			40 ⁽¹⁾	ms
t_{PoR}	Power-on reset assertion time	Internal power-on reset (PoR) stretch between stable power supply and de-assertion of internal PoR. The SMBus address is latched on the completion of the PoR stretch, and SMBus accesses are permitted.			50	ms
POWER SUPPLY						
W_{channel}	Power consumption per active channel	With CTLE, full DFE, Tx FIR, Driver, and Cross-point enabled. Idle power consumption is not included.		241	305	mW
		With CTLE, full DFE, Tx FIR, and Driver enabled; Cross-point disabled. Idle power consumption is not included.		233		mW
		With CTLE, partial DFE (taps 1-2 only), Tx FIR, and Driver enabled; Cross-point and DFE taps 3-5 disabled. Idle power consumption is not included.		220		mW
		With CTLE, Tx FIR, Driver, and Cross-point enabled; DFE disabled. Idle power consumption is not included.		211	290	mW
		Assuming CDR acquiring lock with CTLE, full DFE, Tx FIR, Driver, and Cross-point enabled. Idle power consumption is not included.		365	430	mW
		Assuming CDR acquiring lock with CTLE, Tx FIR, Driver, and Cross-point enabled; DFE disabled. Idle power consumption is not included.		318	393	mW
		PRBS checker power consumption only ⁽²⁾		220	302	mW
		PRBS generator power consumption only ⁽²⁾		230	315	mW
$W_{\text{static_total}}$	Total idle power consumption	Idle or static mode, power supplied, no high-speed data present at inputs, all channels automatically powered down.		658	1050	mW

(1) From low assertion of READ_EN_N to low assertion of ALL_DONE_N. Does not include Power-On Reset time.

(2) To ensure optimal performance, it is recommended to not enable more than two PRBS blocks (checker or generator) per channel quad.

Electrical Characteristics (continued)

Over operating free-air temperature range (unless otherwise noted).

PARAMETER		TEST CONDITIONS	MIN	TYP	MAX	UNIT
I_{total}	Active mode total device supply current consumption	With CTLE, full DFE, Tx FIR, Driver, and Cross-point enabled.		1036	1330	mA
		With CTLE, full DFE, Tx FIR, and Driver enabled; Cross-point disabled.		1010		mA
		With CTLE, partial DFE (taps 1-2 only), Tx FIR, and Driver enabled; Cross-point and DFE taps 3-5 disabled.		970		mA
		With CTLE, Tx FIR, Driver, and Cross-point enabled. DFE disabled.		940	1278	mA
I_{static_total}	Idle mode total device supply current consumption	Idle or static mode. Power supplied, no high-speed data present at inputs, all channels automatically powered down.		263	400	mA

LVC MOS DC SPECIFICATIONS

V_{IH}	Input high level voltage	2.5 V LVC MOS pins	1.75	VDD	V
		3.3 V LVC MOS pin (READ_EN_N)	1.75	3.6	V
V_{IL}	Input low level voltage	2.5 V LVC MOS pins	GND	0.7	V
		3.3 V LVC MOS pin (READ_EN_N)	GND	0.8	V
V_{TH}	High level (1) input voltage	4-level pins ADDR0, ADDR1, and EN_SMB		0.95 * VDD	V
	Float level input voltage	4-level pins ADDR0, ADDR1, and EN_SMB		0.67 * VDD	V
	10 K to GND input voltage	4-level pins ADDR0, ADDR1, and EN_SMB		0.33 * VDD	V
	Low level (0) input voltage	4-level pins ADDR0, ADDR1, and EN_SMB		0.1	V
V_{OH}	High level output voltage	IOH = 4 mA	2		V
V_{OL}	Low level output voltage	IOL = -4 mA		0.4	V
I_{IH}	Input high leakage current	Vinput = VDD, Open drain pins		70	μ A
I_{IH}	Input high leakage current	Vinput = VDD and CAL_CLK_IN pin		65	μ A
I_{IH}	Input high leakage current	Vinput = VDD, ADDR[1:0] and EN_SMB pins		120	μ A
I_{IH}	Input high leakage current	Vinput = VDD, READ_EN_N		75	μ A
I_{IL}	Input low leakage current	Vinput = 0 V, Open drain pins	-15		μ A
I_{IL}	Input low leakage current	Vinput = 0 V, CAL_CLK_IN pins	-45		μ A
I_{IL}	Input low leakage current	Vinput = 0 V, ADDR[1:0], READ_EN_N, and EN_SMB pins	-230		μ A

RECEIVER INPUTS (RXnP, RXnN)

V_{IDMax}	Maximum input differential voltage	For normal operation		1225	mVppd
RL_{SDD11}	Differential input return loss, SDD11	Between 50 MHz and 3.69 GHz		<-16	dB
RL_{SDD11}	Differential input return loss, SDD11	Between 3.69 GHz and 12.9 GHz		<-12	dB
RL_{SDC11}	Differential to common-mode input return loss, SDC11	Between 50 MHz and 12.9 GHz		<-23	dB
RL_{SCD11}	Differential to common-mode input return loss, SCD11	Between 50 MHz and 12.9 GHz		<-24	dB
RL_{SCC11}	Common-mode input return loss, SCC11	Between 150 MHz and 10 GHz		<-10	dB
RL_{SCC11}	Common-mode input return loss, SCC11	Between 10 GHz and 12.9 GHz		<-10	dB

Electrical Characteristics (continued)

Over operating free-air temperature range (unless otherwise noted).

PARAMETER		TEST CONDITIONS	MIN	TYP	MAX	UNIT
V_{SDAT}	AC signal detect assert (ON) threshold level	Minimum input peak-to-peak amplitude level at device pins required to assert signal detect. 25.78125 Gbps with PRBS7 pattern and 20 dB loss channel		196		mVppd
V_{SDDT}	AC signal detect de-assert (OFF) threshold level	Maximum input peak-to-peak amplitude level at device pins which causes signal detect to de-assert. 25.78125 Gbps with PRBS7 pattern and 20 dB loss channel		147		mVppd
TRANSMITTER OUTPUTS (TXnP, TXnN)						
VOD	Output differential voltage amplitude	Measured with c(0)=7 setting (Reg_0x3D[6:0]=0x07, Reg_0x3E[6:0]=0x40, REG_0x3F[6:0]=0x40). Differential measurement using an 8T pattern (eight 1 s followed by eight 0 s) at 25.78125 Gbps with TXPn and TXNn terminated by 50 Ω to GND.		525		mVppd
VOD	Output differential voltage amplitude	Measured with c(0)=31 setting (Reg_0x3D[6:0]=0x1F, Reg_0x3E[6:0]=0x40, REG_0x3F[6:0]=0x40). Differential measurement using an 8T pattern (eight 1 s followed by eight 0 s) at 25.78125 Gbps with TXPn and TXNn terminated by 50 Ω to GND.		1225		mVppd
V_{OD_idle}	Differential output amplitude with TX disabled			< 11		mVppd
V_{OD_res}	Output VOD resolution	Difference in VOD between two adjacent c(0) settings. Applies to VOD in the 525 mVppd to 1225 mVppd range [c(0)>4].		< 50		mVppd
$V_{cm-TX-AC}$	Common-mode AC output noise	With respect to signal ground. Measured with PRBS9 data pattern. Measured with a 33 GHz (-3 dB) low-pass filter.		6.5		mV, RMS
t_r, t_f	Output transition time	20%-to-80% rise time and 80%-to-20% fall time on a clock-like {11111 00000} data pattern at 25.78125 Gbps. Measured for ~800 mVppd output amplitude and no equalization: Reg_0x3D=+13, Reg_0x3E=0, REG_0x3F=0		17		ps
RL_{SDD22}	Differential output return loss, SDD22	Between 50 MHz and 5 GHz		<-12		dB
RL_{SDD22}	Differential output return loss, SDD22	Between 5 GHz and 12.9 GHz		<-9		dB
RL_{SCD22}	Common-mode to differential output return loss, SCD22	Between 50 MHz and 12.9 GHz		<-22		dB
RL_{SDC22}	Differential-to-common-mode output return loss, SDC22	Between 50 MHz and 12.9 GHz		<-22		dB
RL_{SCC22}	Common-mode output return loss, SCC22	Between 50 MHz and 10 GHz		<-9		dB
RL_{SCC22}	Common-mode output return loss, SCC22	Between 10 GHz and 12.9 GHz		<-9		dB
SMBus ELECTRICAL CHARACTERISTICS (SLAVE MODE)						
V_{IH}	Input high level voltage	SDA and SDC	1.75		3.6	V
V_{IL}	Input low level voltage	SDA and SDC	GND		0.8	V

Electrical Characteristics (continued)

Over operating free-air temperature range (unless otherwise noted).

PARAMETER		TEST CONDITIONS	MIN	TYP	MAX	UNIT
C_{IN}	Input pin capacitance			15		pF
V_{OL}	Low level output voltage	SDA or SDC, IOL = 1.25 mA			0.4	V
I_{IN}	Input current	SDA or SDC, VINPUL = VIN, VDD, GND	-15		15	μA
T_R	SDA rise time, read operation	Pull-up resistor = 1 kΩ, Cb = 50 pF		150		ns
T_F	SDA fall time, read operation	Pull-up resistor = 1 kΩ, Cb = 50 pF		4.5		ns

7.6 Timing Requirements, Retimer Jitter Specifications

Over operating free-air temperature range (unless otherwise noted).

PARAMETER		TEST CONDITIONS	MIN	TYP	MAX	UNIT
J_{TJ}	Output Total jitter (TJ)	Measured at 28.4 Gbps to a probability level of 1E-15 with PRBS9 data pattern an evaluation board traces de-embedded.		0.24		U _{Ipp} @ 1E-12
J_{RJ}	Output Random Jitter (RJ)	Measured at 28.4 Gbps to a probability level of 1E-15 with PRBS9 data pattern an evaluation board traces de-embedded		8		mUI RMS
J_{DCD}	Output Duty Cycle Distortion (DCD)	Measured at 28.4 Gbps to a probability level of 1E-15 with PRBS9 data pattern an evaluation board traces de-embedded		15		mUI _{pp}
J_{TJ}	Output Total jitter (TJ)	Measured at 25.78125 Gbps to a probability level of 1E-12 with PRBS11 data pattern an evaluation board traces de-embedded.		0.17		U _{Ipp} @ 1E-12
J_{RJ}	Output Random Jitter (RJ)	Measured at 25.78125 Gbps to a probability level of 1E-12 with PRBS11 data pattern an evaluation board traces de-embedded		6		mUI RMS
J_{DCD}	Output Duty Cycle Distortion (DCD)	Measured at 25.78125 Gbps to a probability level of 1E-12 with PRBS11 data pattern an evaluation board traces de-embedded		4		mUI _{pp}
J_{PEAK}	Jitter peaking	Measured at 10.3125 Gbps with PRBS7 data pattern. Peaking frequency in the range of 1 to 6 MHz.		0.8		dB
J_{PEAK}	Jitter peaking	Measured at 25.78125 Gbps with PRBS7 data pattern. Peaking frequency in the range of 1 to 17 MHz.		0.4		dB
J_{PEAK}	Jitter peaking	Measured at 28.4 Gbps with PRBS7 data pattern. Peaking frequency in the range of 1 to 17 MHz.		0.4		dB
BWPLL	PLL bandwidth	Data rate of 10.3125 Gbps with PRBS7 pattern		5		MHz
BWPLL	PLL bandwidth	Data rate of 25.78125 Gbps with PRBS7 pattern		5.5		MHz
BWPLL	PLL bandwidth	Data rate of 28.4 Gbps with PRBS7 pattern		5		MHz

Timing Requirements, Retimer Jitter Specifications (continued)

Over operating free-air temperature range (unless otherwise noted).

PARAMETER		TEST CONDITIONS	MIN	TYP	MAX	UNIT
J _{TOL}	Input jitter tolerance	Measured at 28.4 Gbps with SJ frequency > 10 MHz, 29 dB input channel loss, PRBS31 data pattern, 800 mVppd launch amplitude, and 0.078 UIpp total uncorrelated output jitter in addition to the applied SJ. BER < 1E-12.		0.32		UIpp
J _{TOL}	Input jitter tolerance	Measured at 25.78125 Gbps with SJ frequency = 190 KHz, 30 dB input channel loss, PRBS31 data pattern, 800 mVppd launch amplitude, and 0.078 UIpp total uncorrelated output jitter in addition to the applied SJ. BER < 1E-12.		9		UIpp
J _{TOL}	Input jitter tolerance	Measured at 25.78125 Gbps with SJ frequency = 940 KHz, 30 dB input channel loss, PRBS31 data pattern, 800 mVppd launch amplitude, and 0.078 UIpp total uncorrelated output jitter in addition to the applied SJ. BER < 1E-12.		1		UIpp
J _{TOL}	Input jitter tolerance	Measured at 25.78125 Gbps with SJ frequency > 10 MHz, 32 dB input channel loss, PRBS31 data pattern, 800 mVppd launch amplitude, and 0.078 UIpp total uncorrelated output jitter in addition to the applied SJ. BER < 1E-12.		0.38		UIpp
TEMP _{LOCK-}	CDR stay-in-lock ambient temperature range, negative ramp. Maximum temperature change below initial CDR lock acquisition temperature.	85 °C starting ambient temperature, ramp rate -3 °C/minute, 1.7 liters/sec airflow, 12 layer PCB.		115		°C
TEMP _{LOCK+}	CDR stay-in-lock ambient temperature range, positive ramp. Maximum temperature change above initial CDR lock acquisition temperature.	-40 °C starting ambient temperature, ramp rate +3 °C/minute, 1.7 liters/sec airflow, 12 layer PCB.		125		°C

7.7 Timing Requirements, Retimer Specifications

Over operating free-air temperature range (unless otherwise noted).

PARAMETER		TEST CONDITIONS	MIN	TYP	MAX	UNIT
t _D	Input-to-output latency (propagation delay) through a channel	No cross-point; CDR enabled and locked.		3.5UI + 125ps		ps
t _D	Input-to-output latency (propagation delay) through a channel	Cross-point enabled; CDR enabled and locked.		3.5UI + 145ps		ps
t _D	Input-to-output latency (propagation delay) through a channel	No cross-point; CDR in raw mode. 25.78125 Gbps data rate.		< 145		ps
t _{SK}	Channel-to-channel inter-pair skew	Latency difference between channels at full-rate. 25.78125 Gbps data rate		< 30		ps
t _{lock}	CDR lock acquisition time	Measured at 25.78125 Gbps, Adapt Mode = 1 (Reg_0x31[6:5]=0x1), EOM timer = 0x5 (Reg_0x2A[7:4]=0x5).		< 100		ms
t _{lock}	CDR lock acquisition time	Measured at 10.3125 Gbps, Adapt Mode = 1 (Reg_0x31[6:5]=0x1), EOM timer = 0x5 (Reg_0x2A[7:4]=0x5).		< 100		ms

7.8 Timing Requirements, Recommended Calibration Clock Specifications

Over operating free-air temperature range (unless otherwise noted).

PARAMETER		TEST CONDITIONS	MIN	TYP	MAX	UNIT
CLK _f	Calibration clock frequency			25		MHz
CLK _{PPM}	Calibration clock PPM tolerance		-100		100	PPM
CLK _{IDC}	Recommended/tolerable input duty cycle		40%	50%	60%	
CLK _{ODC}	Intrinsic calibration clock duty cycle distortion	Intrinsic duty cycle distortion of chip calibration clock output at the CAL_CLK_OUT pin, assuming 50% duty cycle on CAL_CLK_IN pin.	45%		55%	
CLK _{num}	Number of devices which can be cascaded from CAL_CLK_OUT to CAL_CLK_IN	Assumes worst-case 60% and 40% input duty cycle on the first device. CAL_CLK_OUT from first device connects to CAL_CLK_IN of second device, and so on until the last device.		20		N/A

7.9 Recommended SMBus Switching Characteristics (Slave Mode)

Over operating free-air temperature range (unless otherwise noted).

PARAMETER		TEST CONDITIONS	MIN	TYP	MAX	UNIT
f _{SDC}	SDC clock frequency		10	100	400	kHz
t _{HD-DAT}	Data hold time			0.75		ns
t _{SU-DAT}	Data setup time			100		ns

7.10 Recommended SMBus Switching Characteristics (Master Mode)

Over operating free-air temperature range (unless otherwise noted).

PARAMETER		TEST CONDITIONS	MIN	TYP	MAX	UNIT
f _{SDC}	SDC clock frequency		260	303	346	kHz
T _{LOW}	SDC low period		1.66	1.90	2.21	μs
T _{HIGH}	SDC high period		1.22	1.40	1.63	μs
T _{HD-STA}	Hold time start operation			0.6		μs
T _{SU-STA}	Setup time start operation			0.6		μs
T _{HD-DAT}	Data hold time			0.6		μs
T _{SD-DAT}	Data setup time			0.1		μs
T _{SU-STO}	Stop condition setup time			0.6		μs
T _{BUF}	Bus free time between Stop-Start			1.3		μs
T _R	SDC rise time	Pull-up resistor = 1 kΩ		300		ns
T _F	SDC fall time	Pull-up resistor = 1 kΩ		300		ns

7.11 Typical Characteristics

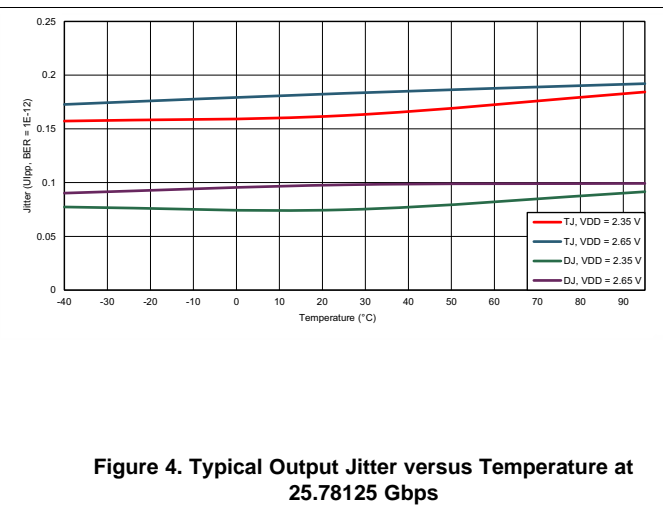
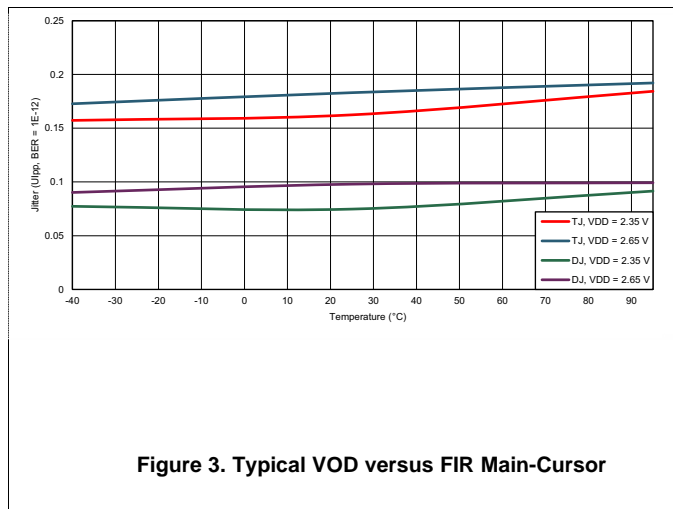
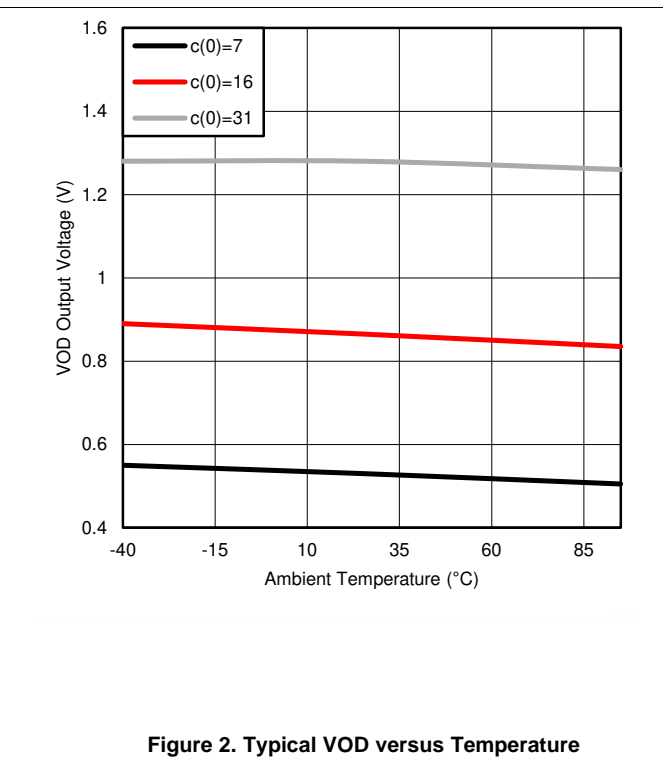
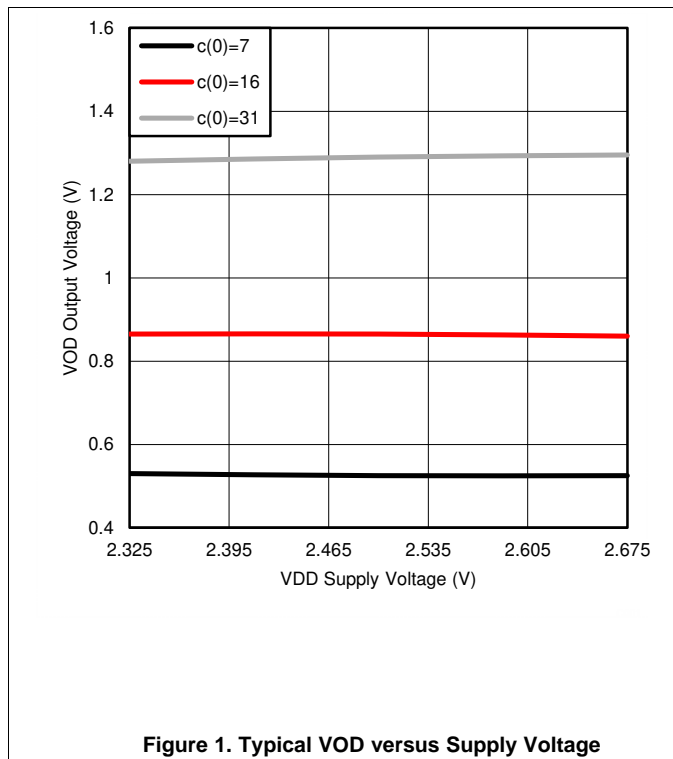

8 Detailed Description

8.1 Overview

The DS280DF810 is an eight-channel multi-rate retimer with integrated signal conditioning. Each of the eight channels operates independently. Each channel includes a continuous-time linear equalizer (CTLE) and a Decision Feedback Equalizer (DFE), which together compensate for the presence of a dispersive transmission channel between the source transmitter and the DS280DF810 receiver. The CTLE and DFE are self-adaptive.

Each channel includes an independent voltage-controlled oscillator (VCO) and phase-locked loop (PLL) which produce a clean clock that is frequency-locked to the clock embedded in the input data stream. The high-frequency jitter on the incoming data is attenuated by the PLL, producing a clean clock with substantially-reduced jitter. This clean clock is used to re-time the incoming data, removing high-frequency jitter from the data stream and reproducing the data on the output with significantly-reduced jitter.

Each channel of the DS280DF810 features an output driver with adjustable differential output voltage and output equalization in the form of a three-tap finite impulse response (FIR) filter. The output FIR compensates for dispersion in the transmission channel at the output of the DS280DF810.

All transmit and receive channels on the DS280DF810 are AC-coupled with physical AC-coupling capacitors (220 nF +/- 20%) on the package substrate. This ensures common mode voltage compatibility with all link partners and eliminates the need for AC coupling capacitors on the system PCB, thereby saving cost and greatly reducing PCB routing complexity.

Between each group of two adjacent channels (e.g. between channels 0–1, 2–3, 4–5, and 6–7) is a full 2x2 cross-point switch. This allows multiplexing and de-multiplexing and fanout applications for fail-over redundancy, as well as cross-over applications to aid PCB routing.

Each channel also includes diagnostic features such as a Pseudo Random Bit Sequence (PRBS) pattern generator and checker, as well as a non-destructive eye opening monitor (EOM). The EOM can be used to plot the post-equalized eye at the input to the decision slicer or simply to read the horizontal eye opening (HEO) and vertical eye opening (VEO).

The DS280DF810 is configurable through a single SMBus port. The DS280DF810 can also act as an SMBus master to configure itself from an EEPROM. Up to sixteen DS280DF810 devices can share a single SMBus.

The sections which follow describe the functionality of various circuits and features within the DS280DF810. For more information about how to program or operate these features, consult the DS280DF810 Programming Guide.

8.2 Functional Block Diagram

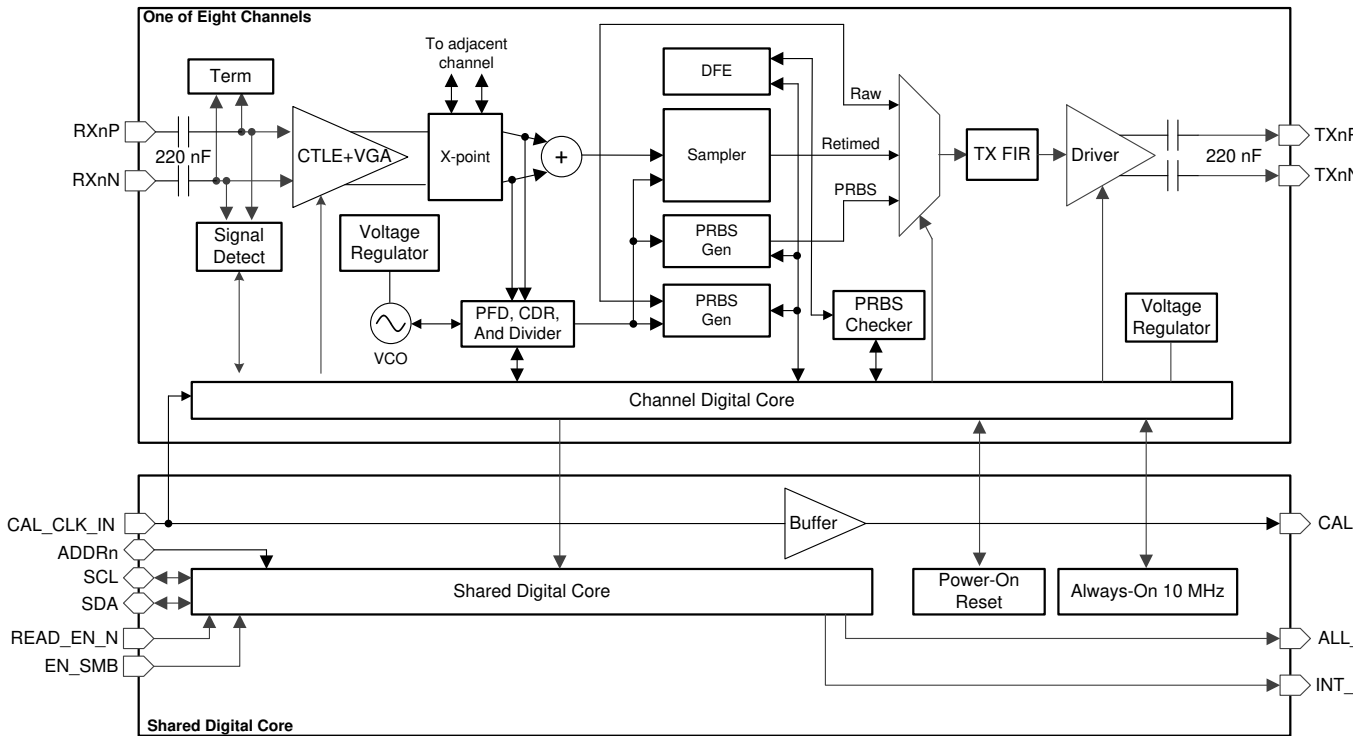

8.3 Feature Description

8.3.1 Device Data Path Operation

The DS280DF810 data path consists of several key blocks as shown in the functional block diagram. These key circuits are:

- [AC-Coupled Receiver and Transmitter](#)
- [Signal Detect](#)
- [Continuous Time Linear Equalizer \(CTLE\)](#)
- [Variable Gain Amplifier \(VGA\)](#)
- [2x2 Cross-point Switch](#)
- [Decision Feedback Equalizer \(DFE\)](#)
- [Clock and Data Recovery \(CDR\)](#)
- [Calibration Clock](#)
- [Differential Driver with FIR Filter](#)
- [Differential Driver with FIR Filter](#)

8.3.1.1 AC-Coupled Receiver and Transmitter

The differential receiver for each DS280DF810 channel contains on-package AC coupling capacitors. The differential transmitter for each DS280DF810 channel also implement on-package AC coupling capacitors. The AC coupling capacitors have a value of 220nF +/- 20%.

8.3.1.2 Signal Detect

The DS280DF810 receiver contains a signal detect circuit. The signal detect circuit monitors the energy level on the receiver inputs and powers on or off the rest of the high-speed data path if a signal is detected or not. By default, each channel allows the signal detect circuit to automatically power on or off the rest of the high speed data path depending on the presence of an input signal. The signal detect block can be manually controlled in the SMBus channel registers. This can be useful if it is desired to manually force channels to be disabled. For information on how to manually operate the signal detect circuit refer to the DS280DF810 Programming Guide.

8.3.1.3 Continuous Time Linear Equalizer (CTLE)

The CTLE in the DS280DF810 is a fully-adaptive equalizer. The CTLE adapts according to a Figure of Merit (FOM) calculation during the lock acquisition process. The FOM calculation is based upon the horizontal eye opening (HEO) and vertical eye opening (VEO). Once the CDR locks and the CTLE adapts, the CTLE boost level is frozen until a manual re-adapt command is issued or until the CDR re-enters the lock acquisition state. The CTLE can be re-adapted by resetting the CDR.

The CTLE consists of 4 stages, with each stage having 2-bit boost control. This allows for 256 different boost combinations. The CTLE adaption algorithm allows the CTLE to adapt through 16 of these boost combinations. These 16 boost combinations comprise the EQ Table in the channel registers. See channel registers 0x40 through 0x4F. This EQ Table can be reprogrammed to support up to 16 of the 256 boost settings.

The boost levels can be set between 8 dB and 25 dB (at 14 GHz).

8.3.1.4 Variable Gain Amplifier (VGA)

The DS280DF810 receiver implements a VGA. The VGA assists in the recovery of extremely small signals, working in conjunction with the CTLE to equalize and scale amplitude. The VGA has 1-bit control via Register 0x8E[0], and the VGA is enabled by default. In addition to the VGA, the CTLE implements its own gain control via register 0x13[5] to adjust the DC amplitude similar to the VGA. For more information on how to configure the VGA refer to the DS280DF810 Programming Guide.

8.3.1.5 2x2 Cross-point Switch

Between each group of two adjacent channels (i.e between channels 0–1, 2–3, 4–5, and 6–7) is a full 2x2 cross-point switch. The cross-point can be configured through SMBus registers to operate as follows:

- Straight-thru mode
- Multiplex two inputs to one output

Feature Description (continued)

- Fanout one input to two outputs
- Cross two inputs to two outputs

Figure 5 shows the four 2x2 cross-points available in the DS280DF810, and Figure 6 shows how each cross-point can be configured for straight-thru, multiplex, de-multiplex, or cross-over applications. Refer to the DS280DF810 Programming Guide for details on how to program the cross-point through SMBus registers.

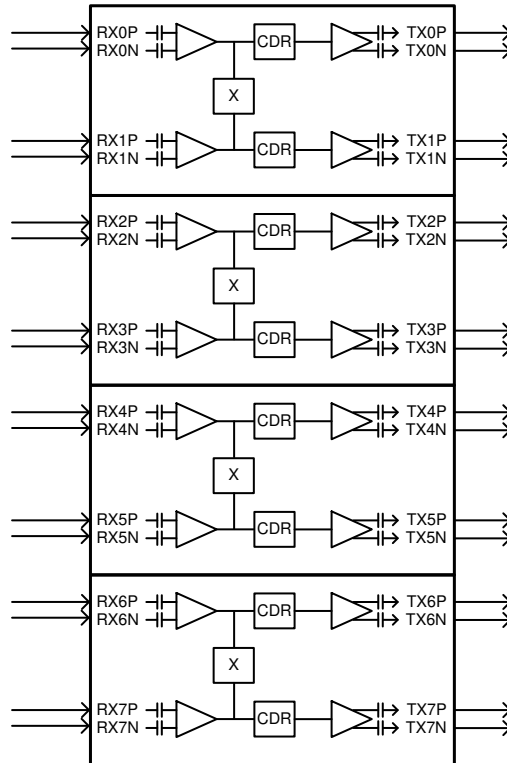

Figure 5. Block diagram showing all four 2x2 cross-points in the DS280DF810

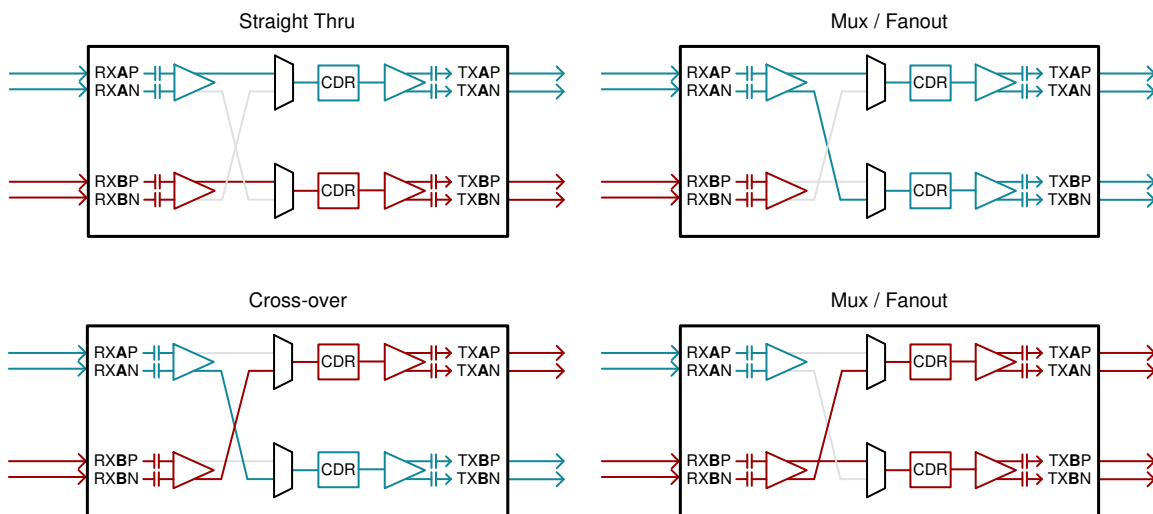

Figure 6. Signal distribution options available in each 2x2 cross-point (channel A can be 0, 2, 4, or 6; channel B can be 1, 3, 5, or 7)

Feature Description (continued)

8.3.1.6 Decision Feedback Equalizer (DFE)

A 5-tap DFE can be enabled within the data path of each channel to assist with reducing the effects of cross talk, reflections, or post cursor inter-symbol interference (ISI). The DFE must be manually enabled, regardless of the selected adapt mode. Once the DFE has been enabled it can be configured to adapt only during lock acquisition or to adapt continuously. The DFE can also be manually configured to specified tap polarities and tap weights. However, when the DFE is configured manually the DFE auto-adaptation should be disabled. For many applications with lower insertion loss (i.e. < 30 dB) lower crosstalk, or lower reflections, part or all of the DFE can be disabled to reduce power consumption. The DFE can either be fully enabled (taps 1-5), partially enabled (taps 1-2 only), or fully disabled (no taps).

The DFE taps are all feedback taps with 1 UI spacing. Each tap has a specified boost weight range and polarity bit.

Table 1. DFE Tap Weights

DFE PARAMETER	DECIMAL (REGISTER VALUE)	VALUE (mV) (TYP)
Tap 1 Weight Range	0 - 31	0 – 217
Tap 2-5 Weight Range	0 - 15	0 – 105
Tap Weight Step Size	NA	7
Polarity	0: (+) positive; feedback value creates a low-pass filter response, thus providing attenuation to correct for negative-sign post-cursor ISI 1: (-) negative; Feedback value creates a high-pass filter response, thus providing boost to correct for positive-sign post-cursor ISI.	

8.3.1.7 Clock and Data Recovery (CDR)

The CDR consists of a Phase Locked Loop (PLL), PPM counter, and Input and Output Data Multiplexers (mux) allowing for retimed data, un-retimed data, PRBS generator and output muted modes.

By default, the equalized data is fed into the CDR for clock and data recovery. The recovered data is then output to the FIR filter and differential driver together with the recovered clock which has been cleaned of any high-frequency jitter outside the bandwidth of the CDR clock recovery loop. The bandwidth of the CDR defaults to 5.5 MHz (typical) in full-rate (divide-by-1) mode and 5.3 MHz (typical) in sub-rate mode. The CDR bandwidth is adjustable. Refer to the DS280DF810 Programming Guide for more information on adjusting the CDR bandwidth. Users can configure the CDR data to route the recovered clock and data to the PRBS checker. Users also have the option of configuring the output of the CDR to send raw non-retimed data, or data from the pattern generator.

The CDR requires the following in order to be properly configured:

- 25 MHz calibration clock to run the PPM counter (CAL_CLK_IN).
- Expected data rates must be programmed into the CDR either through the rate table or entered manually with the corrected divider settings. Refer to the Programming Guide for more information on configuring the CDR for different data rates.

8.3.1.8 Calibration Clock

The calibration clock is not part of the CDR's PLL and thus is not used for clock and data recovery. The calibration clock is connected only to the PPM counter for each CDR. The PPM counter constrains the allowable lock ranges of the CDR according to the programmed values in the rate table or the manually entered data rates. The host should provide an input calibration clock signal of 25 MHz frequency. Because this clock is not used for clock and data recovery, there are no stringent jitter requirements placed on this 25 MHz calibration clock.

8.3.1.9 Differential Driver with FIR Filter

The DS280DF810 output driver has a three-tap finite impulse response (FIR) filter which allows for pre- and post-cursor equalization to compensate for a wide variety of output channel media. The filter consists of a weighted sum of three consecutive retimed bits as shown in the following diagram. C[0] can take on values in the range [-31, +31]. C[-1] and C[+1] can take on values in the range [-15, 15].

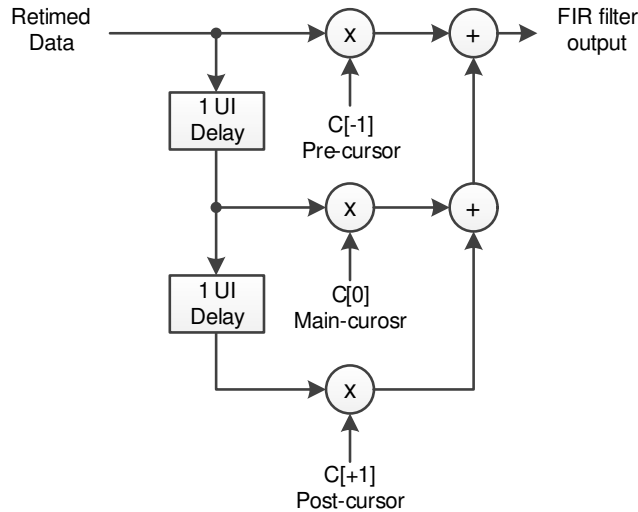

Figure 7. FIR filter functional model

When utilizing the FIR filter, it is important to abide by the following general rules:

- $|C[-1]| + |C[0]| + |C[+1]| \leq 31$; the FIR tap coefficients absolute sum must be less or equal to 31).
- $\text{sgn}(C[-1]) = \text{sgn}(C[+1]) \neq \text{sgn}(C[0])$, for high-pass filter effect; the sign for the pre-cursor or post-cursor tap must be different from main-cursor tap to realize boost effect.
- $\text{sgn}(C[-1]) = \text{sgn}(C[+1]) = \text{sgn}(C[0])$, for low-pass filter effect; the sign for the pre-cursor or post-cursor tap must be equal to the main-cursor tap to realize attenuation effect.

The FIR filter is used to pre-distort the transmitted waveform in order to compensate for frequency-dependant loss in the output channel. The most common way of pre-distorting the signal is to accentuate the transitions and de-emphasize the non-transitions. The bit before a transition is accentuated via the pre-cursor tap, and the bit after the transition is accentuated via the post-cursor tap. The figures below give a conceptual illustration of how the FIR filter affects the output waveform. The following characteristics can be derived from the example waveforms.

- $VOD_{pk-pk} = V_7 - V_8$
- $VOD_{low-frequency} = V_2 - V_5$
- $Rpre_{dB} = 20 * \log_{10} (v_3/v_2)$
- $Rpst_{dB} = 20 * \log_{10} (v_1/v_2)$

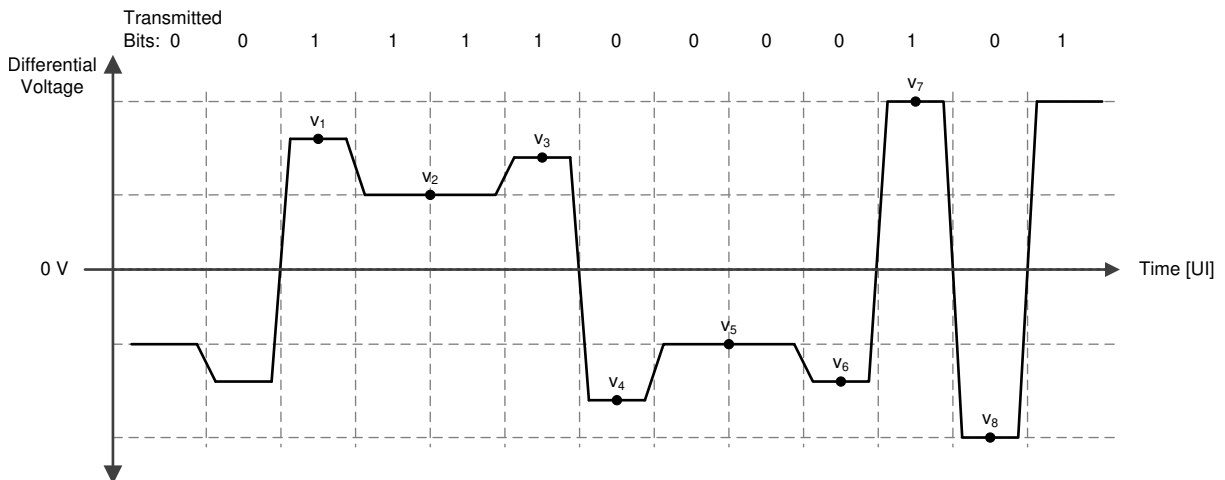

Figure 8. Conceptual FIR Waveform With Post-Cursor Only

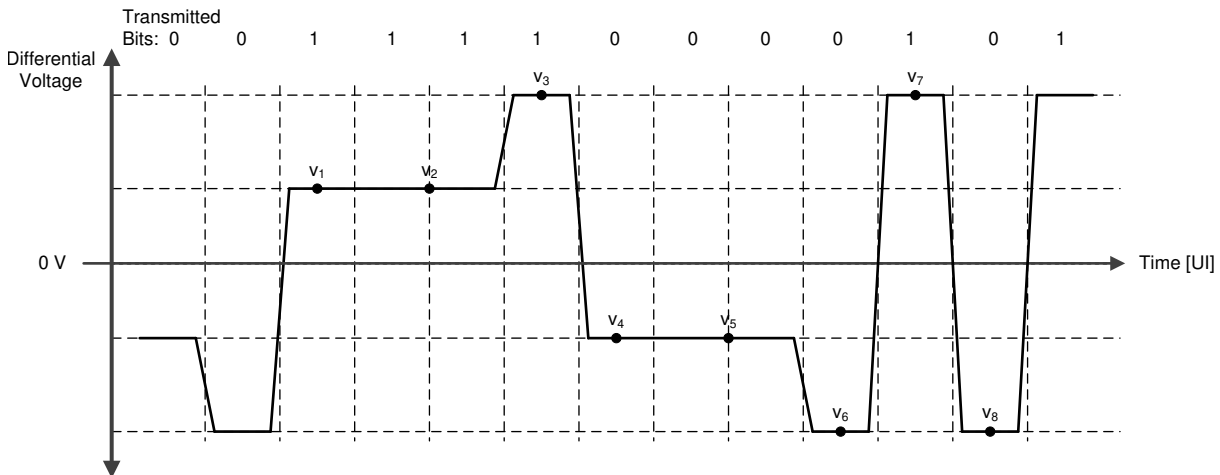

Figure 9. Conceptual FIR Waveform With Pre-Cursor Only

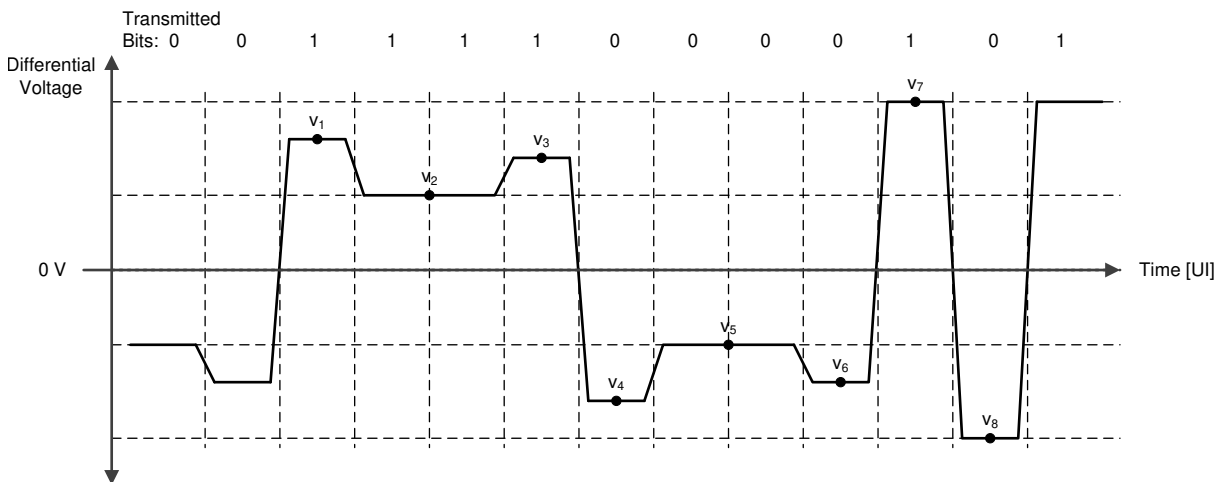

Figure 10. Conceptual FIR Waveform With Both Pre-Cursor and Post-Cursor

8.3.1.9.1 Setting the Output V_{OD} , Pre-Cursor, and Post-Cursor Equalization

The output differential voltage (V_{OD}) of the driver is controlled by manipulating the FIR tap settings. The main cursor tap is the primary knob for amplitude adjustment. The pre and post cursor FIR tap settings can then be adjusted to provide equalization. To maintain a constant peak-to-peak V_{OD} , the user should adjust the main cursor tap value relative to the pre tap or post tap changes so as to maintain a constant absolute sum of the FIR tap values. The table below shows various settings for V_{OD} settings ranging from 205 mVpp to 1225 mVpp (typical). Note that the output peak-to-peak amplitude is a function of the sum of the absolute values of the taps, whereas the low-frequency amplitude is purely a function of the main-cursor value.

Table 2. Typical V_{OD} and FIR Values

FIR SETTINGS			PEAK-TO PEAK $V_{OD}(V)$	RPRE(dB)	RPST(dB)
PRE-CURSOR: REG_0x3E[6:0]	MAIN-CURSOR: REG_0x3D[6:0]	POST-CURSOR: REG_0x3F[6:0]			
0	0	0	0.205	NA	NA
0	+1	0	0.260	NA	NA
0	+2	0	0.305	NA	NA
0	+3	0	0.355	NA	NA

Table 2. Typical VOD and FIR Values (continued)

FIR SETTINGS			PEAK-TO PEAK VOD(V)	RPRE(dB)	RPST(dB)
PRE-CURSOR: REG_0x3E[6:0]	MAIN-CURSOR: REG_0x3D[6:0]	POST-CURSOR: REG_0x3F[6:0]			
0	+4	0	0.395	NA	NA
0	+5	0	0.440	NA	NA
0	+6	0	0.490	NA	NA
0	+7	0	0.525	NA	NA
0	+8	0	0.565	NA	NA
0	+9	0	0.610	NA	NA
0	+10	0	0.650	NA	NA
0	+11	0	0.685	NA	NA
0	+12	0	0.720	NA	NA
0	+13	0	0.760	NA	NA
0	+14	0	0.790	NA	NA
0	+15	0	0.825	NA	NA
0	+16	0	0.860	NA	NA
0	+17	0	0.890	NA	NA
0	+18	0	0.925	NA	NA
0	+19	0	0.960	NA	NA
0	+20	0	0.985	NA	NA
0	+21	0	1.010	NA	NA
0	+22	0	1.040	NA	NA
0	+23	0	1.075	NA	NA
0	+24	0	1.095	NA	NA
0	+25	0	1.125	NA	NA
0	+26	0	1.150	NA	NA
0	+27	0	1.165	NA	NA
0	+28	0	1.190	NA	NA
0	+29	0	1.205	NA	NA
0	+30	0	1.220	NA	NA
0	+31	0	1.225	NA	NA
0	+18	-1	0.960	NA	2.1
0	+17	-2	0.960	NA	2.5
0	+16	-3	0.960	NA	3.1
0	+15	-4	0.960	NA	3.8
0	+14	-5	0.960	NA	4.7
0	+13	-6	0.960	NA	5.8
0	+12	-7	0.960	NA	7.2
0	+11	-8	0.960	NA	9.0
0	+10	-9	0.960	NA	11.6
-1	18	0	0.960	1.0	NA
-2	17	0	0.960	1.6	NA
-3	16	0	0.960	2.4	NA
-4	15	0	0.960	3.3	NA
0	26	-1	1.165	NA	1.1
0	25	-2	1.165	NA	1.3
0	24	-3	1.165	NA	1.8
0	23	-4	1.165	NA	2.2
0	22	-5	1.165	NA	2.7

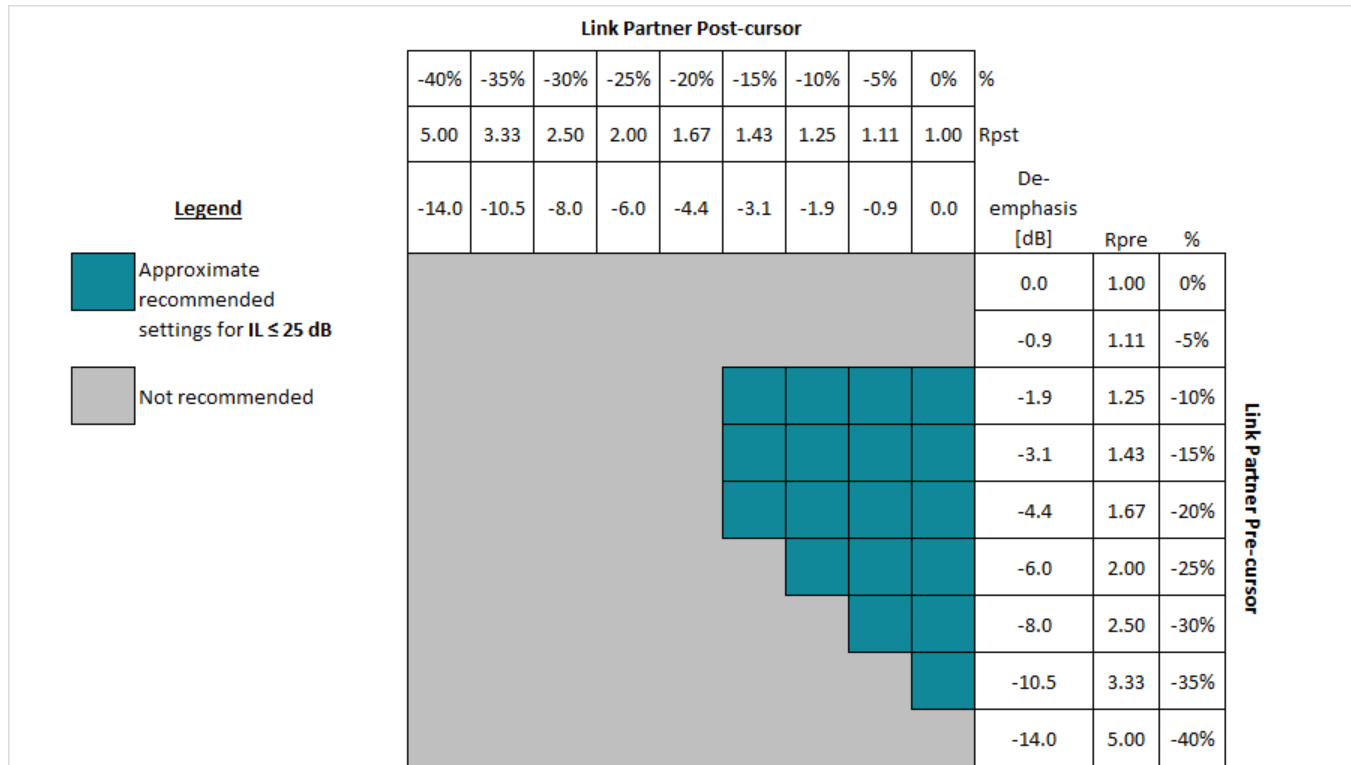

Figure 12. Guideline for Link partner FIR Settings When IL ≤ 25 dB

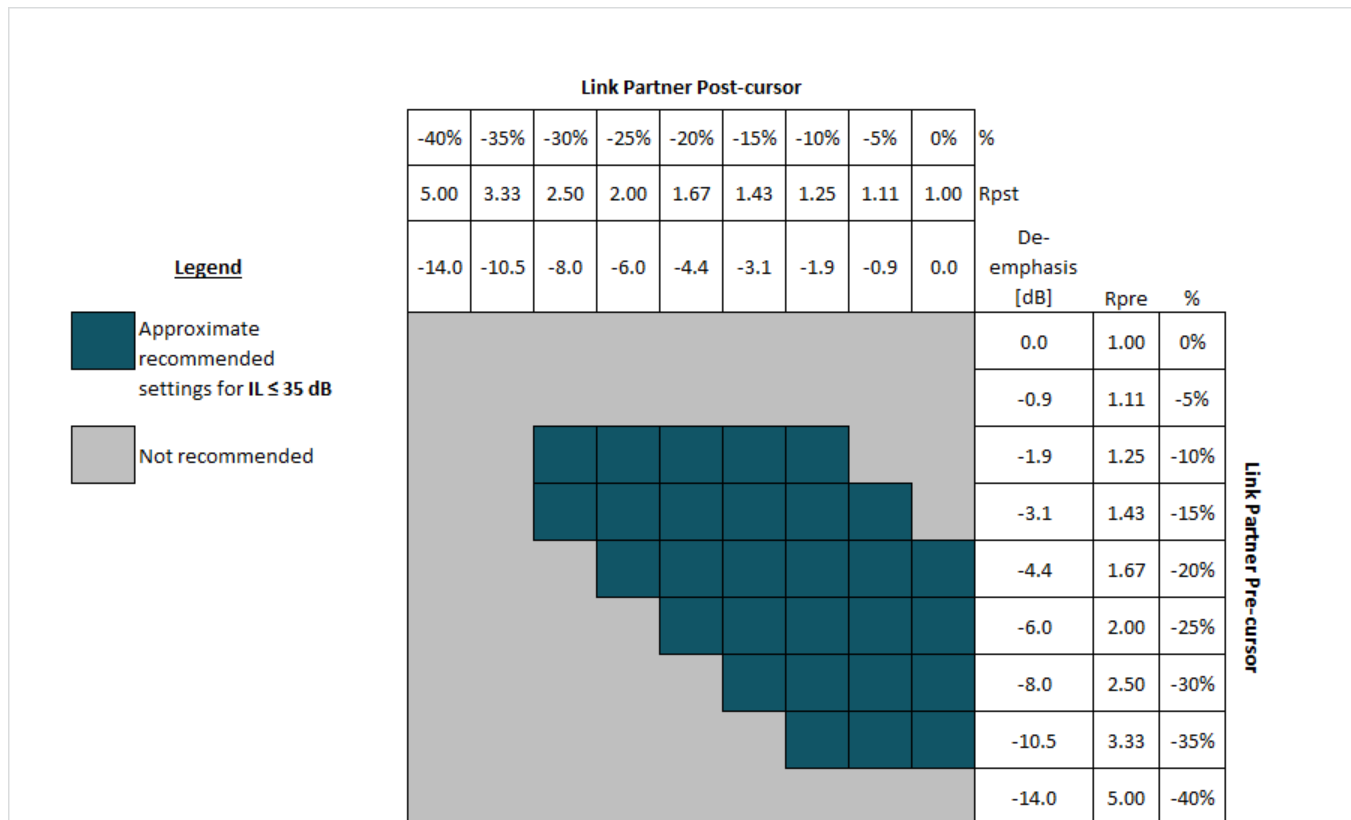

Figure 13. Guideline for Link partner FIR Settings When IL ≤ 35 dB

8.3.1.9.2 Output Driver Polarity Inversion

In some applications, it may be necessary to invert the polarity of the data transmitted from the retimer. To invert the polarity of the data, read back the FIR polarity settings for the pre-cursor, main-cursor, and post-cursor taps and then invert all of these polarities. Refer to the DS280DF810 Programming Guide for more details.

8.3.2 Debug Features

The DS280DF810 has multiple features to aid diagnostics, board manufacturing, and system debug. These key features are:

- [Pattern Generator](#)
- [Pattern Checker](#)
- [Eye Opening Monitor](#)
- [Interrupt Signals](#)

8.3.2.1 Pattern Generator

Each channel in the DS280DF810 can be configured to generate a 16-bit user-defined data pattern or a pseudo random bit sequence (PRBS). The user defined pattern can also be set to automatically invert every other 16-bit symbol for DC balancing purposes. The DS280DF810 pattern generator supports the following PRBS sequences:

- PRBS – $2^7 - 1$
- PRBS – $2^9 - 1$
- PRBS – $2^{11} - 1$
- PRBS – $2^{15} - 1$
- PRBS – $2^{23} - 1$
- PRBS – $2^{31} - 1$
- PRBS – $2^{58} - 1$
- PRBS – $2^{63} - 1$

8.3.2.2 Pattern Checker

The pattern checker can be manually set to look for specific PRBS sequences and polarities or it can be set to automatically detect the incoming pattern and polarity. The PRBS checker supports the same set of PRBS patterns as the PRBS generator.

The pattern checker consists of an 11-bit error counter. The pattern checker uses 32-bit words, but every bit in the word is checked for error, so the error count represents the count of single bit errors.

In order to read out the bit and error counters, the pattern checker must first be frozen. Continuous operation with simultaneous read out of the bit and error counters is not supported in this implementation. Once the bit and error counter is read, they can be un-frozen to continue counting.

8.3.2.3 Eye Opening Monitor

The DS280DF810's Eye Opening Monitor (EOM) measures the internal data eye at the input of the decision slicer and can be used for 2 functions:

1. Horizontal Eye Opening (HEO) and Vertical Eye Opening (VEO) measurement
2. Full Eye Diagram Capture

The HEO measurement is made at the 0 V crossing and is read in channel register 0x27. The VEO measurement is made at the 0.5 UI mark and is read in channel register 0x28. The HEO and VEO registers can be read from channel registers 0x27 and 0x28 at any time while the CDR is locked. The following equations are used to convert the contents of channel registers 0x27 and 0x28 into their appropriate units:

- $\text{HEO [UI]} = \text{Reg_0x27} \div 32$
- $\text{VEO [mV]} = \text{Reg_0x28} \times 3.125$

A full eye diagram capture can be performed when the CDR is locked. The eye diagram is constructed within a 64 x 64 array, where each cell in the matrix consists of an 16-bit word representing the total number of hits recorded at that particular phase and voltage offset. Users can manually adjust the vertical scaling of the EOM or allow the state machine to control the scaling which is the default option. The horizontal scaling controlled by the state machine and is always directly proportional to the data rate.

When a full eye diagram plot is captured, the retimer will shift out four 16-bit words of junk data that should be discarded followed by 4096 16-bit words that make up the 64 x 64 eye plot. The first actual word of the eye plot from the retimer is for (X, Y) position (0,0), which is the earliest position in time and the most negative position in voltage. Each time the eye plot data is read out the voltage position is incremented. Once the voltage position has incremented to position 63 (the most positive voltage), the next read will cause the voltage position to reset to 0 (the most negative voltage) and the phase position to increment. This process will continue until the entire 64 x 64 matrix is read out. Figure 14 below shows the EOM read out sequence overlaid on top of a simple eye opening plot. In this plot any hits are shown in green. This type of plot is helpful for quickly visualizing the HEO and VEO. Users can apply different algorithms to the output data to plot density or color gradients to the output data.

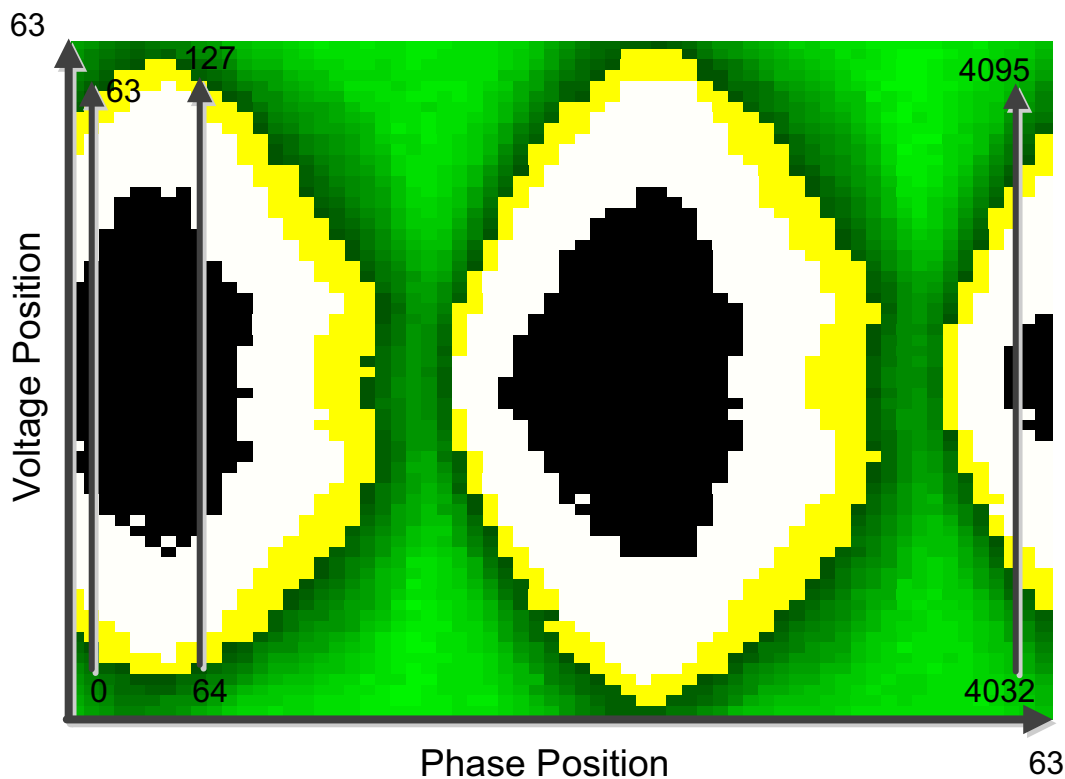

Figure 14. EOM Full Eye Capture Readout

To manually control the EOM vertical range, remove scaling control from the state machine then select the desired range:

Channel Reg 0x2C[6] → 0 (see Table 3).

Table 3. Eye Opening Monitor Vertical Range Settings

CH REG 0x11[7:6] VALUE	EOM VERTICAL RANGE [mV]
2'b00	±100
2'b01	±200
2'b10	±300
2'b11	±400

The EOM operates as an under-sampled circuit. This allows the EOM to be useful in identifying over equalization, ringing and other gross signal conditioning issues. However, the EOM cannot be correlated to a bit error rate.

The EOM can be accessed in two ways to read out the entire eye plot:

- Multi-byte reads can be used such that data is repeatedly latched out from channel register 0x25.
- With single byte reads, the MSB are located in register 0x25 and the LSB are located in register 0x26. In this mode, the device must be addressed each time a new byte is read.

To perform a full eye capture with the EOM, follow these steps below within the desired channel register set:

Table 4. Eye Opening Monitor Full Eye Capture Instructions

STEP	REGISTER [bits]	OPERATION	VALUE	DESCRIPTION
1	0x67[5]	Write	0	Disable lock EOM lock monitoring
2	0x2C[6]	Write	0	Set the desired EOM vertical range
	0x11[7:6]	Write	2'b--	
3	0x11[5]	Write	0	Power on the EOM
4	0x24[7]	Write	1	Enable fast EOM
5	0x24[0] 0x25 0x26	Read	1	Begin read out of the 64 x 64 array, discard first 4 words Ch reg 0x24[0] is self-clearing.
				0x25 is the MSB of the 16-bit word
				0x26 is the LSB of the 16-bit word
6	0x25	Read		Continue reading information until the 64 x 64 array is complete.
	0x26			
7	0x67[5]	Write	1	Return the EOM to its original state. Undo steps 1-4
	0x2C[6]	Write	1	
	0x11[5]	Write	1	
	0x24[7]	Write	0	

8.3.2.4 Interrupt Signals

The DS280DF810 can be configured to report different events as interrupt signals. These interrupt signals do not impact the operation of the device, but merely report that the selected event has occurred. The interrupt bits in the register sets are all sticky bits. This means that when an event triggers an interrupt the status bit for that interrupt is set to logic HIGH. This interrupt status bit will remain at logic HIGH until the bit has been read. Once the bit has been read it will be automatically cleared, which allows for new interrupts to be detected. The DS280DF810 will report the occurrence of an interrupt through the INT_N pin. The INT_N pin is an open drain output that will pull the line low when an interrupt signal is triggered.

Note that all available interrupts are disabled by default. Users must activate the various interrupts before they can be used.

The interrupts available in the DS280DF810 are:

- CDR loss of lock
- CDR locked
- Signal detect loss
- Signal detected
- PRBS pattern checker bit error detected
- HEO/VEO threshold violation

When an interrupt occurs, share register 0x08 reports which channel generated the interrupt request. Users can then select the channels that generated the interrupt request and service the interrupt by reading the appropriate interrupt status bits in the corresponding channel registers. For more information on reading interrupt status, refer to the DS280DF810 Programming Guide.

8.4 Device Functional Modes

8.4.1 Supported Data Rates

The DS280DF810 supports a wide range of input data rates, including divide-by-2 and divide-by-4 sub-rates. The supported data rates are listed in [Table 5](#). Refer to the DS280DF810 Programming Guide for information on configuring the DS280DF810 for different data rates.

Table 5. Supported Data Rates

DATA RATE RANGE		DIVIDER	CDR MODE	COMMENT
MIN	MAX			
≥ 20.2 Gbps	≤ 28.4 Gbps	1	Enabled	
≥ 10.1 Gbps	≤ 14.2 Gbps	2	Enabled	
> 7.1 Gbps	< 10.1 Gbps	N/A	Disabled	Output jitter will be higher with CDR disabled.
≥ 5.05 Gbps	≤ 7.1 Gbps	4	Enabled	
≥ 1.25 Gbps	< 5.05 Gbps	N/A	Disabled	Output jitter will be higher with CDR disabled.

8.4.2 SMBus Master Mode

SMBus master mode allows the DS280DF810 to program itself by reading directly from an external EEPROM. When using the SMBus master mode, the DS280DF810 will read directly from specific location in the external EEPROM. When designing a system for using the external EEPROM, the user needs to follow these specific guidelines:

- Maximum EEPROM size is 2048 Bytes
- Minimum EEPROM size for a single DS280DF810 with individual channel configuration is 595 Bytes (3 base header bytes + 12 address map bytes + 8 x 72 channel register bytes + 2x2 share register bytes; bytes are defined to be 8-bits)
- Set ENSMB = Float, for SMBus master mode
- The external EEPROM device address byte must be 0xA0
- The external EEPROM device must support 400 kHz operation at 2.5 V or 3.3 V supply
- Set the SMBus address of the DS280DF810 by configuring the ADDR0 and ADDR1 pins

When loading multiple DS280DF810 devices from the same EEPROM, use these guidelines to configure the devices:

- Configure the SMBus addresses for each DS280DF810 to be sequential. The first device in the sequence must have an address of 0x30
- Daisy chain READ_EN_N and ALL_DONE_N from one device to the next device in the sequence so that they do not compete for the EEPROM at the same time.
- If all of the DS280DF810 devices share the same EEPROM channel and share register settings, configure the common channel bit in the base header to 1. With common channel configuration enabled, each DS280DF810 device will configure all 8 channels with the same settings.

When loading a single DS280DF810 from an EEPROM, use these guidelines to configure the device:

- Set the common channel bit to 0 to allow for individual channel configuration, or set the common channel bit to 1 to load the same configuration settings to all channels.
- When configuring individual channels, a 1024 Byte or 2048 Byte EEPROM must be used.
- If there are more than three DS280DF810 devices on a PCB that require individual channel configuration, then each device must have its own EEPROM.

8.4.3 Device SMBus Address

The DS280DF810's SMBus slave address is strapped at power up using the ADDR[1:0] pins. The pin state is read on power up, after the internal power-on reset signal is de-asserted. The ADDR[1:0] pins are four-level LVCMOS IOs, which provides for 16 unique SMBus addresses. The four levels are achieved by pin strap options as follows:

- 0: 1 kΩ to GND

- R: 10 kΩ to GND
- F: Float
- 1: 1 kΩ to VDD

Table 6. SMBus Address Map

8-BIT WRITE ADDRESS [HEX]	REQUIRED ADDRESS PIN STRAP VALUE	
	ADDR1	ADDR0
0x30	0	0
0x32	0	R
0x34	0	F
0x36	0	1
0x38	R	0
0x3A	R	R
0x3C	R	F
0x3E	R	1
0x40	F	0
0x42	F	R
0x44	F	F
0x46	F	1
0x48	1	0
0x4A	1	R
0x4C	1	F
0x4E	1	1

8.5 Programming

8.5.1 Bit Fields in the Register Set

Many of the registers in the DS280DF810 are divided into bit fields. This allows a single register to serve multiple purposes which may be unrelated. Often, configuring the DS280DF810 requires writing a bit field that makes up only part of a register value while leaving the remainder of the register value unchanged. The procedure for accomplishing this task is to read in the current value of the register to be written, modify only the desired bits in this value, and write the modified value back to the register. Of course, if the entire register is to be changed, rather than just a bit field within the register, it is not necessary to read in the current value of the register first. In all register configuration procedures described in the following sections, this procedure should be kept in mind. In some cases, the entire register is to be modified. When only a part of the register is to be changed, however, the procedure described above should be used.

Each bit or field within a register has one of the following access properties:

- **R**: Read-only
- **RW**: Read or Write
- **RWSC**: Read or Write, self-clearing

8.5.2 Writing to and Reading from the Global/Shared/Channel Registers

The DS280DF810 has 3 types of registers:

- 1) Global Registers – These registers can be accessed at any time and are used to select individual channel registers, the shared registers or to read back the TI ID and version information.
- 2) Shared Registers – These registers are used for device-level configuration, status read back or control.
- 3) Channel Registers – These registers are used to control and configure specific features for each individual channel. All channels have the same channel register set and can be configured independent of each other.

The global registers can be accessed at any time, regardless of whether the shared or channel register set is selected. The DS280DF810 global registers are located on addresses 0xEF-0xFF. The function of the global registers falls into the following categories:

Programming (continued)

- Channel selection and share enabling – Registers 0xFC and 0xFF
- Device and version information – Registers 0xEF-0xF3
- Reserved or unused registers – all other addresses

Register 0xFF[5:4] selects the share registers of either Quad 0 (channels 0-3) or Quad 1 (channels 4-7).

Register 0xFC is used to select the channel registers to be written to. To select a channel, write a 1 to its corresponding bit in register 0xFC. Note that more than one channel may be written to by setting multiple bits in register 0xFC. However, when performing an SMBus read transaction only one channel can be selected at a time. If multiple channels are selected when attempting to perform an SMBus read, the device will return 0xFF.

Register 0xFF bit 1 can be used to perform broadcast register writes to all channels. A single channel read-modify broadcast write type commands can be accomplished by setting register 0xFF to 0x03 and selecting a single channel in register 0xFC. This type of configuration allows for the reading of a single channel's register information and then writing to all channels with the modified value. Register 0xFF bit 0 is used to select the shared register page or the channel register page for the channels selected in register 0xFC.

TI repeaters and retimers have a vendor ID register (0xFE) which will always read back 0x03. In addition, there are three device ID registers (0xF0, 0xF1, and 0xF3). These are useful to verify that there is a good SMBus connection between the SMBus master and the DS280DF810.

8.6 Register Maps

Refer to the DS280DF810 Programming Guide (SNLU182) for the complete register map and example programming sequences.

The DS280DF810 has a vendor ID register (0xFE), which will always read back 0x03. In addition, there are four device ID registers (0xEF, 0xF0, 0xF1, and 0xF3). Reading these five registers and confirming the expected value is a good way to verify SMBus communications between the SMBus Master and the DS280DF810. In addition, writing a value to channel select Reg_0xFC and confirming the correct value is read back is a good way to verify SMBus write communications with the DS280DF810.

Table 7. Device and Vendor ID Registers

Global Register	Description
0xEF	TI device ID (Quad count). DS280DF810: 0x0C
0xF0	TI version ID. DS280DF810: 0x31
0xF1	TI device ID. DS280DF810: 0x13
0xF3	TI channel and share version ID. Contains 0x00.
0xFE	TI vendor ID. Contains 0x03.

9 Application and Implementation

NOTE

Information in the following applications sections is not part of the TI component specification, and TI does not warrant its accuracy or completeness. TI's customers are responsible for determining suitability of components for their purposes. Customers should validate and test their design implementation to confirm system functionality.

9.1 Application Information

The DS280DF810 is a high-speed retimer which extends the reach of differential channels and cleans jitter and other signal impairments in the process. It can be deployed in a variety of different systems from backplanes to front ports to active cable assemblies. The following sections outline typical applications and their associated design considerations.

9.2 Typical Application

The DS280DF810 is typically used in the following application scenarios:

1. [Backplane and Mid-Plane Reach Extension Application](#)
2. [Front-Port Jitter Cleaning Application](#)

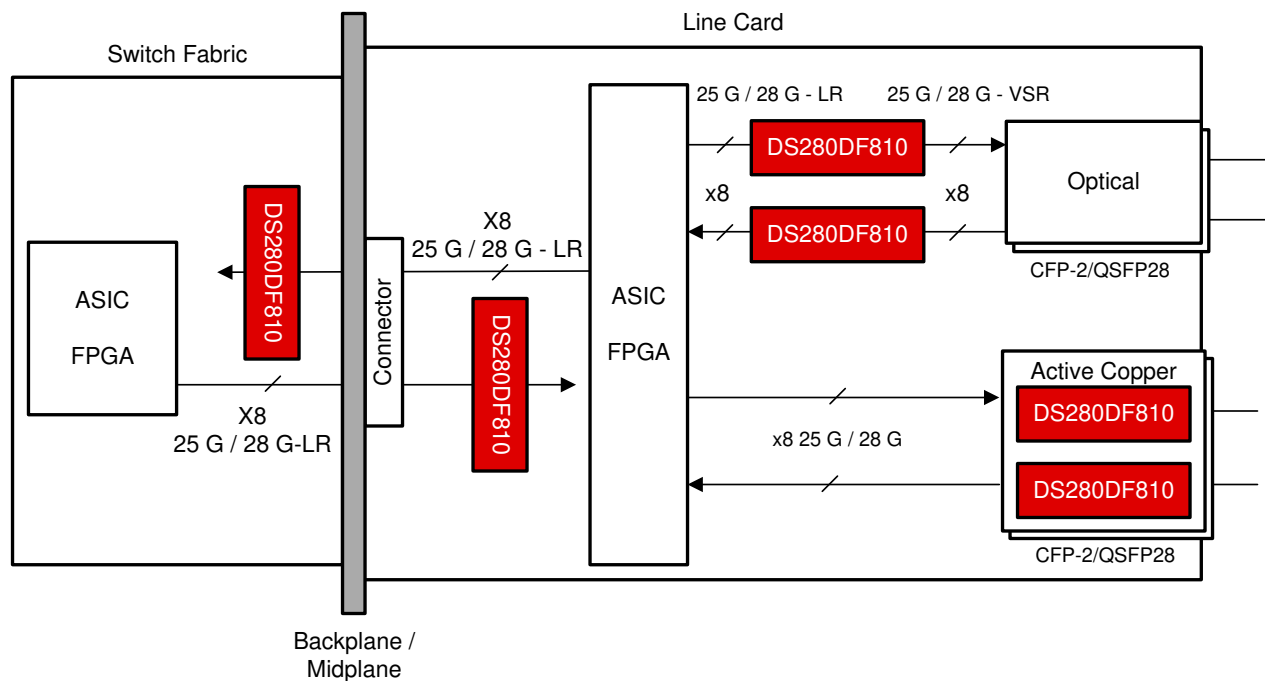

Figure 15. Typical uses for the DS280DF810 in a system

Typical Application (continued)

9.2.1 Backplane and Mid-Plane Reach Extension Application

The DS280DF810 has strong equalization capabilities that allow it to recover data over channels up to 35 dB insertion loss (at 12.9 GHz). As a result, the optimum placement for the DS280DF810 in a backplane and mid-plane application is with the higher-loss channel segment at the input and the lower-loss channel segment at the output. This reduces the equalization burden on the downstream ASIC/FPGA, as the DS280DF810 is equalizing a majority of the overall channel. This type of asymmetric placement is not a requirement, but when an asymmetric placement is required due to the presence of a passive backplane or mid-plane, then this becomes the recommended placement.

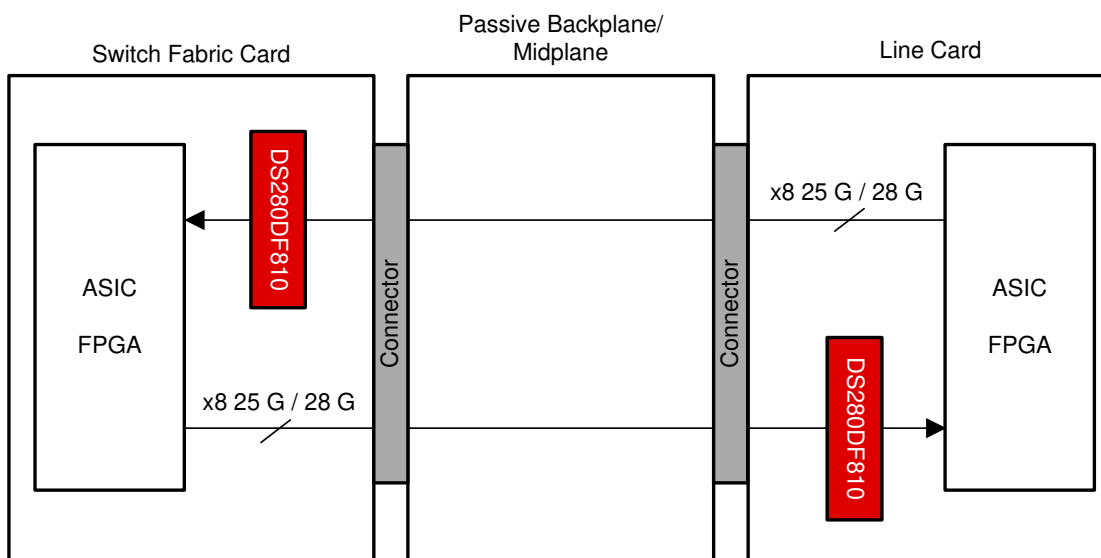
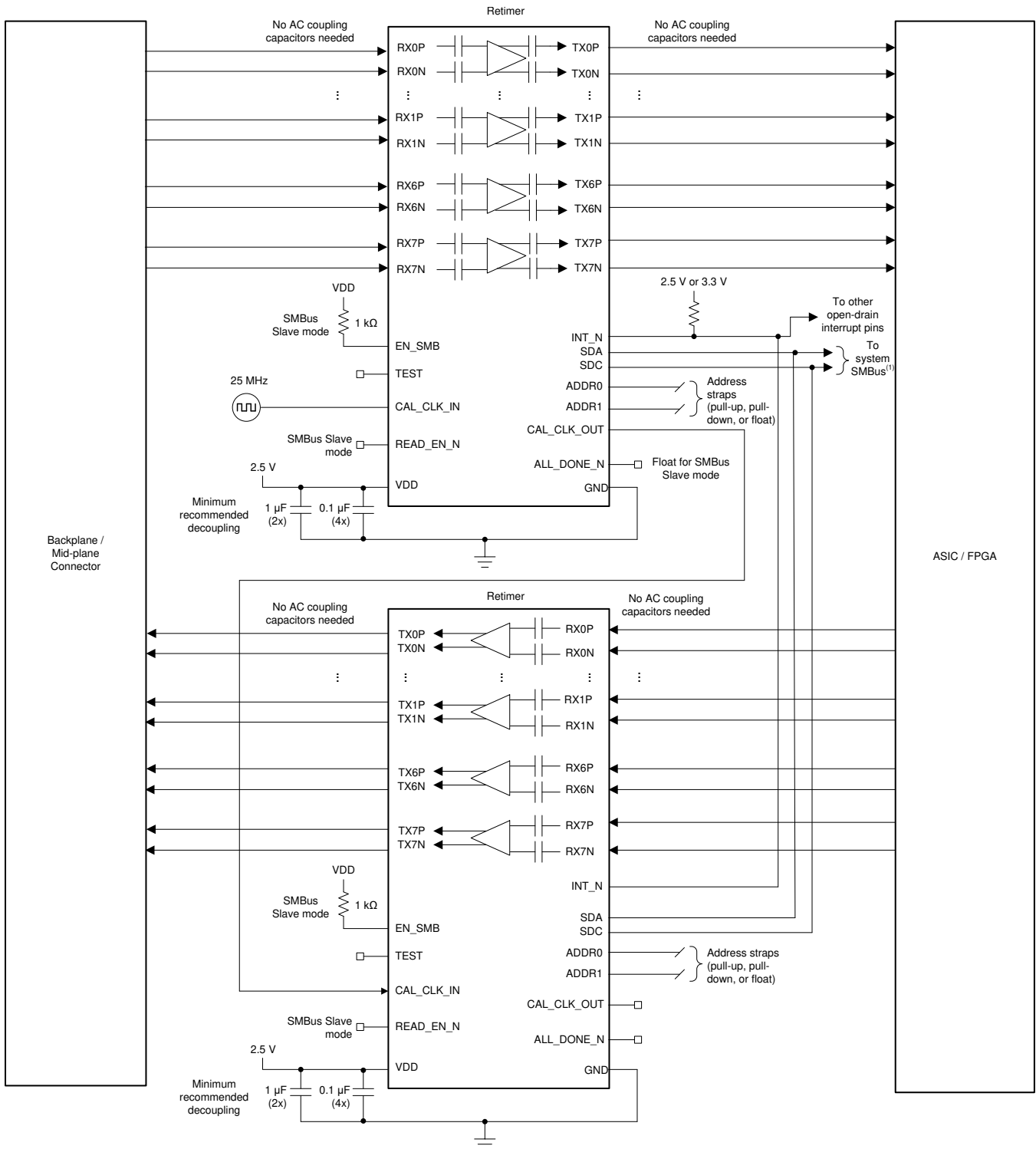

Figure 16. Backplane and Mid-Plane Application Block Diagram

Typical Application (continued)



(1) SMBus signals need to be pulled up elsewhere in the system.

Figure 17. Backplane and Mid-Plane Application Schematic

Typical Application (continued)

9.2.1.1 Design Requirements

For this design example, the following guidelines outlined in [Table 8](#) apply.

Table 8. Backplane and Mid-Plane Application Design Guidelines

DESIGN PARAMETER	REQUIREMENT
AC coupling capacitors	Not required. AC coupling capacitors are included in the device package.
Input channel insertion loss	≤ 35 dB at 25.78125 Gbps Nyquist frequency ≤ 30 dB at 28 Gbps Nyquist frequency
Output channel insertion loss	Depends on downstream ASIC and FPGA capabilities. The DS280DF810 has a low-jitter output driver with 3-tap FIR filter for equalizing a portion of the output channel.
Link partner TX launch amplitude	800 mVppd to 1200 mVppd
Link partner TX FIR filter	Depends on channel loss

9.2.1.2 Detailed Design Procedure

The design procedure for backplane and mid-plane applications is as follows:

- Determine the total number of channels on the board which require a DS280DF810 for signal conditioning. This will dictate the total number of DS280DF810 devices required for the board. It is generally recommended that channels with similar total insertion loss on the board be grouped together in the same DS280DF810 device. This will simplify the device settings, as similar loss channels generally utilize similar settings.
- Determine the maximum current draw required for all DS280DF810 retimers. This may impact the selection of the regulator for the 2.5 V supply rail. To calculate the maximum current draw, multiply the maximum transient power supply current by the total number of DS280DF810 devices.
- Determine the maximum operational power consumption for the purpose of thermal analysis. There are two ways to approach this calculation:
 - Maximum mission-mode operational power consumption is when all channels are locked and retransmitting the data which is received. PRBS pattern checkers and generators are not used in this mode since normal traffic cannot be checked with a PRBS checker. For this calculation, multiply the worst-case power consumption in mission mode by the total number of DS280DF810 devices.
 - Maximum debug-mode operational power consumption is when all channels are locked and retransmitting the data which is received. At the same time, some channels' PRBS checkers or generators may be enabled. For this calculation, multiply the worst-case power consumption in debug mode by the total number of DS280DF810 devices.
- Determine the SMBus address scheme needed to uniquely address each DS280DF810 device on the board. Each DS280DF810 can be strapped with one of 16 unique SMBus addresses. If there are more DS280DF810 devices on the board than the number of unique SMBus addresses which can be assigned, then use an I²C expander like the **TCA/PCA family of I²C/SMBus switches and multiplexers** to split up the SMBus into multiple busses.
- Determine if the device will be configured from EEPROM (SMBus Master Mode) or from the system I²C bus (SMBus Slave Mode).
 - If SMBus Master Mode will be used, provisions should be made for an EEPROM on the board with 8-bit SMBus address 0xA0.
 - If SMBus Slave Mode will be used for all device configurations, an EEPROM is not needed.
- Make provisions in the schematic and layout for standard decoupling capacitors between the device VDD supply and GND. Refer to the pin function description in [Pin Configuration and Functions](#) for more details.

7. Make provisions in the schematic and layout for a 25 MHz (± 100 ppm) single-ended CMOS clock. Each DS280DF810 retimer buffers the clock on the CAL_CLK_IN pin and presents the buffered clock on the CAL_CLK_OUT pin. This allows multiple (up to 20) retimers' calibration clocks to be daisy chained to avoid the need for multiple oscillators on the board. If the oscillator used on the board has a 2.5 V CMOS output, then no AC coupling capacitor or resistor ladder is required at the input to CAL_CLK_IN. No AC coupling or resistor ladder is needed between one retimer's CAL_CLK_OUT output and the next retimer's CAL_CLK_IN input. The final retimer's CAL_CLK_OUT output can be left floating.
8. Connect the INT_N open-drain output to an FPGA or CPU if interrupt monitoring is desired. Note that multiple retimers' INT_N outputs can be connected together since this is an open-drain output. The common INT_N net should be pulled high.
9. If the application requires initial CDR lock acquisition at the ambient temperature extremes defined in [Timing Requirements, Retimer Jitter Specifications](#), then care should be taken to ensure the operating junction temperature is met as well as the CDR stay-in-lock ambient temperature range defined in [Timing Requirements, Retimer Jitter Specifications](#). For example, if initial CDR lock acquisition occurs at an ambient temperature of 85 °C, then maintaining CDR lock would require the ambient temperature surrounding the DS280DF810 to be kept above (85 °C - TEMP_{LOCK}-).

9.2.2 Front-Port Jitter Cleaning Application

The DS280DF810 has strong equalization capabilities that allow it to equalize insertion loss, reduce jitter, and extend the reach of front-port interfaces. A single DS280DF810 can be used to support all eight *egress* channels for a stacked QSFP cage. Another DS280DF810 can be used to support all eight *ingress* channels for the same stacked QSFP cage. Alternatively, a single DS280DF810 can be used to support all egress and ingress channels for a single QSFP port.

For applications which require IEEE802.3 100GBASE-CR4 or 25GBASE-CR auto-negotiation and link training, a linear repeater device such as the DS280BR820 (or similar) is recommended.

Figure 18 illustrates this configuration, and [Timing Requirements](#), [Retimer Jitter Specifications](#) shows an example simplified schematic for a typical front-port application.

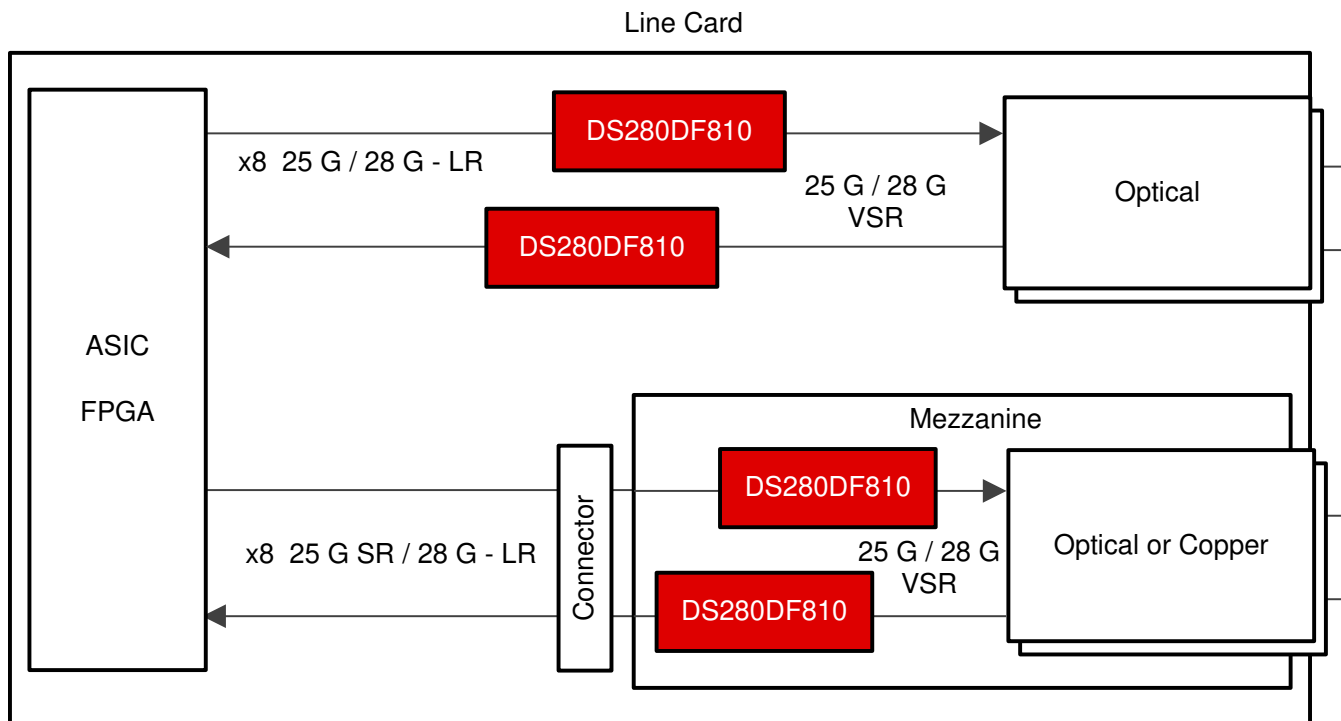
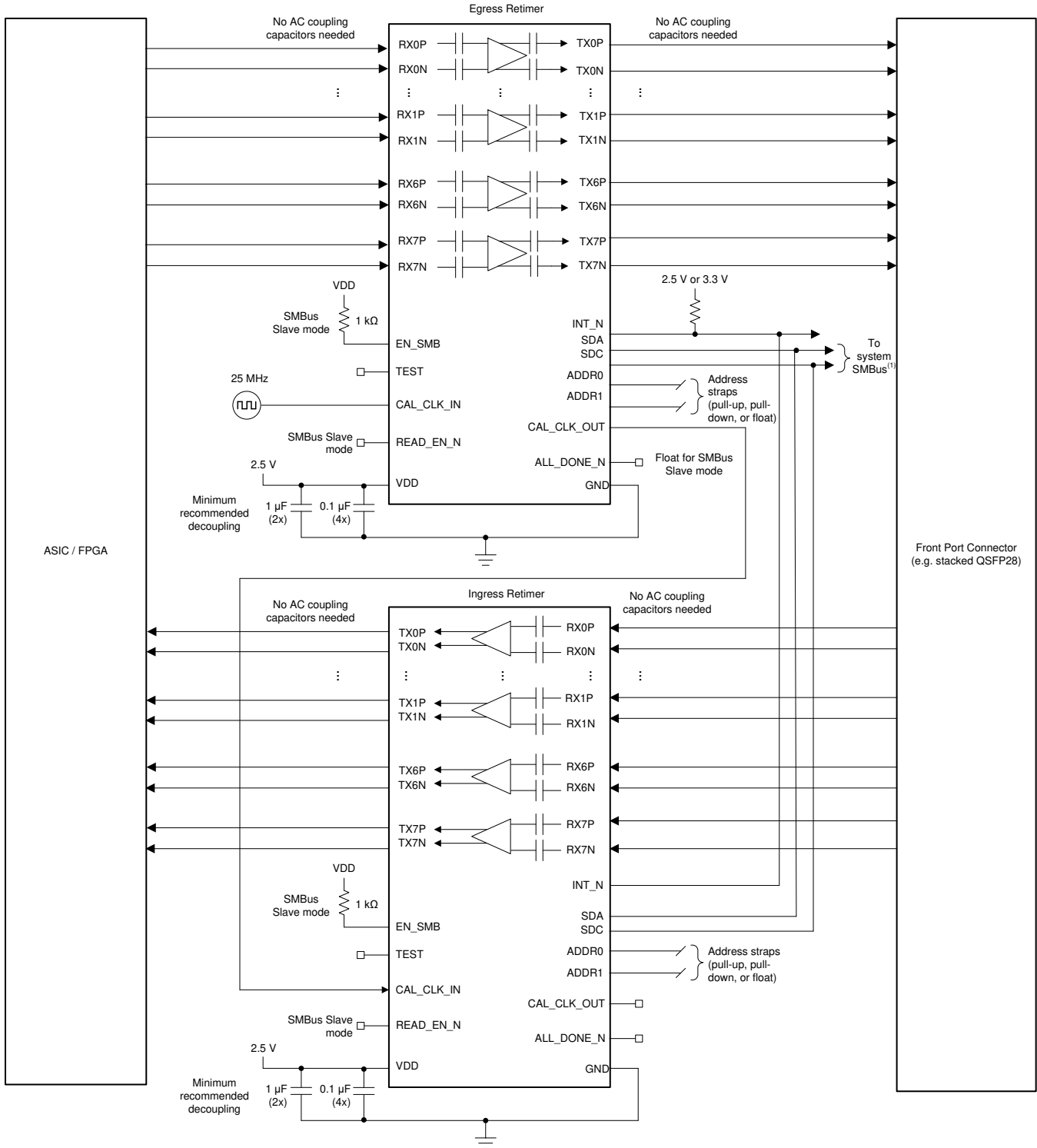

Figure 18. Front-Port Application Block Diagram



(1) SMBus signals need to be pulled up elsewhere in the system.

Figure 19. Front-Port Application Schematic

9.2.2.1 Design Requirements

For this design example, the following guidelines outlined in [Table 9](#) apply.

Table 9. Front-Port Application Design Guidelines

DESIGN PARAMETER	REQUIREMENT
AC coupling capacitors	Not required. AC coupling capacitors are included in the device package.
Input channel insertion loss	≤ 35 dB at 25.78125 Gbps Nyquist frequency. ≤ 30 dB at 28 Gbps Nyquist frequency.
Output channel insertion loss	<i>Egress (ASIC-to-module) direction:</i> Follow CAUI-4 / CEI-25G-VSR host channel requirements (approximately 7 dB at 12.9 GHz). <i>Ingress (module-to-ASIC) direction:</i> Depends on downstream ASIC and FPGA capabilities. The DS280DF810 has a low-jitter output driver with 3-tap FIR filter for equalizing a portion of the output channel.
Host ASIC TX launch amplitude	800 mVppd to 1200 mVppd
Host ASIC TX FIR filter	Depends on channel loss. Refer to Setting the Output V_{OD}, Pre-Cursor, and Post-Cursor Equalization .

9.2.2.2 Detailed Design Procedure

The design procedure for front-port applications is as follows:

- Determine the total number of channels on the board which require a DS280DF810 for signal conditioning. This will dictate the total number of DS280DF810 devices required for the board. It is generally recommended that channels with similar total insertion loss on the board be grouped together in the same DS280DF810 device. This will simplify the device settings, as similar loss channels generally utilize similar settings.
- Determine the maximum current draw required for all DS280DF810 retimers. This may impact the selection of the regulator for the 2.5 V supply rail. To calculate the maximum current draw, multiply the maximum transient power supply current by the total number of DS280DF810 devices.
- Determine the maximum operational power consumption for the purpose of thermal analysis. There are two ways to approach this calculation:
 - Maximum mission-mode operational power consumption is when all channels are locked and retransmitting the data which is received. PRBS pattern checkers and generators are not used in this mode since normal traffic cannot be checked with a PRBS checker. For this calculation, multiply the worst-case power consumption in mission mode by the total number of DS280DF810 devices.
 - Maximum debug-mode operational power consumption is when all channels are locked and retransmitting the data which is received. At the same time, some channels' PRBS checkers or generators may be enabled. For this calculation, multiply the worst-case power consumption in debug mode by the total number of DS280DF810 devices.
- Determine the SMBus address scheme needed to uniquely address each DS280DF810 device on the board. Each DS280DF810 can be strapped with one of 16 unique SMBus addresses. If there are more DS280DF810 devices on the board than the number of unique SMBus addresses which can be assigned, then use an I²C expander like the **TCA/PCA family of I²C/SMBus switches and multiplexers** to split up the SMBus into multiple busses.
- Determine if the device will be configured from EEPROM (SMBus Master Mode) or from the system I²C bus (SMBus Slave Mode).
 - If SMBus Master Mode will be used, provisions should be made for an EEPROM on the board with 8-bit SMBus address 0xA0.
 - If SMBus Slave Mode will be used for all device configurations, an EEPROM is not needed.
- Make provisions in the schematic and layout for standard decoupling capacitors between the device VDD supply and GND. Refer to the pin function description in [Pin Configuration and Functions](#) for more details.

7. Make provisions in the schematic and layout for a 25 MHz (± 100 ppm) single-ended CMOS clock. Each DS280DF810 retimer buffers the clock on the CAL_CLK_IN pin and presents the buffered clock on the CAL_CLK_OUT pin. This allows multiple (up to 20) retimers' calibration clocks to be daisy chained to avoid the need for multiple oscillators on the board. If the oscillator used on the board has a 2.5 V CMOS output, then no AC coupling capacitor or resistor ladder is required at the input to CAL_CLK_IN. No AC coupling or resistor ladder is needed between one retimer's CAL_CLK_OUT output and the next retimer's CAL_CLK_IN input. The final retimer's CAL_CLK_OUT output can be left floating.
8. Connect the INT_N open-drain output to an FPGA or CPU if interrupt monitoring is desired. Note that multiple retimers' INT_N outputs can be connected together since this is an open-drain output. The common INT_N net should be pulled high.
9. If the application requires initial CDR lock acquisition at the ambient temperature extremes defined in [Timing Requirements, Retimer Jitter Specifications](#), care should be taken to ensure the operating junction temperature is met as well as the CDR stay-in-lock ambient temperature range defined in [Timing Requirements, Retimer Jitter Specifications](#). For example, if initial CDR lock acquisition occurs at an ambient temperature of 85 °C, then maintaining CDR lock would require the ambient temperature surrounding the DS280DF810 to be kept above (85 °C - TEMP_{LOCK}-).

9.2.3 Application Curves

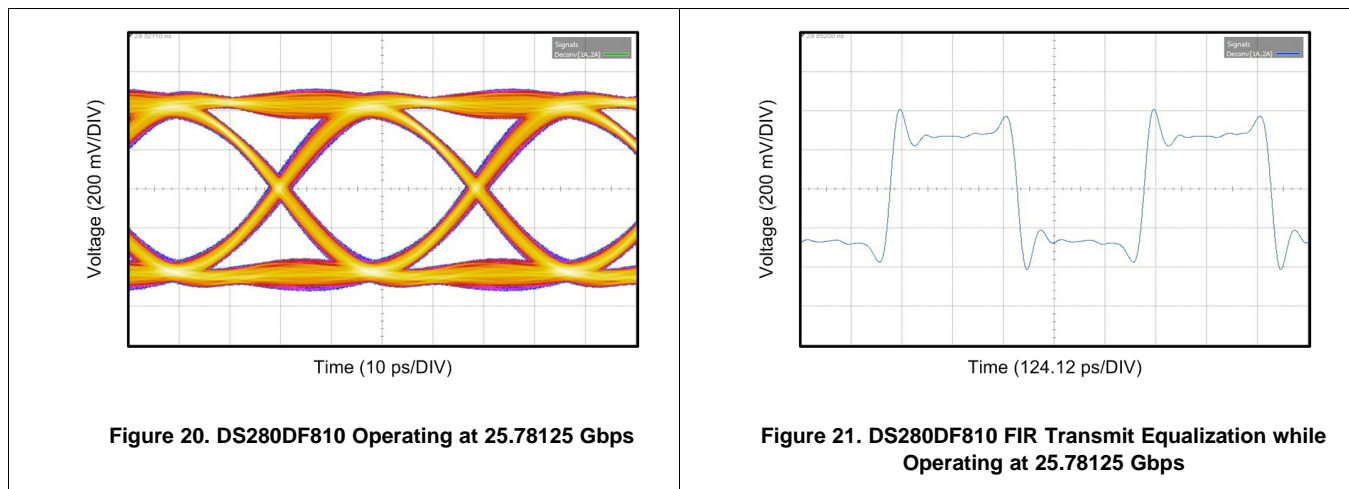

Figure 20. DS280DF810 Operating at 25.78125 Gbps

Figure 21. DS280DF810 FIR Transmit Equalization while Operating at 25.78125 Gbps

Figure 20 shows a typical output eye diagram for the DS280DF810 operating at 25.78125 Gbps with PRBS9 pattern using FIR main-cursor of +18, pre-cursor of -1 and post-cursor of +2. All other device settings are left at default.

Figure 21 shows an example of DS280DF810 FIR transmit equalization while operating at 25.78125 Gbps. In this example, the Tx FIR filter main-cursor is set to +15, post-cursor to -3 and pre-cursor to -3. An 8T pattern is used to evaluate the FIR filter, which consists of 0xFF00. All other device settings are left at default.

10 Power Supply Recommendations

Follow these general guidelines when designing the power supply:

1. The power supply should be designed to provide the recommended operating conditions outlined in [Specifications](#) in terms of DC voltage, AC noise, and start-up ramp time.
2. The maximum current draw for the DS280DF810 is provided in [Specifications](#). This figure can be used to calculate the maximum current the supply must provide. Typical mission-mode current draw can be inferred from the typical power consumption in [Specifications](#).
3. The DS280DF810 does not require any special power supply filtering (that is, ferrite bead) provided the recommended operating conditions are met. Only standard supply decoupling is required. Refer to [Pin Configuration and Functions](#) for details concerning the recommended supply decoupling.

11 Layout

11.1 Layout Guidelines

The following guidelines should be followed when designing the layout:

1. Decoupling capacitors should be placed as close to the VDD pins as possible. Placing them directly underneath the device is one option if the board design permits.
2. High-speed differential signals TXnP/TXnN and RXnP/RXnN should be tightly coupled, skew matched, and impedance controlled.
3. Vias should be avoided when possible on the high-speed differential signals. When vias must be used, care should be taken to minimize the via stub, either by transitioning through most or all layers, or by back drilling.
4. GND relief can be used beneath the high-speed differential signal pads to improve signal integrity by counteracting the pad capacitance.
5. GND vias should be placed directly beneath the device connecting the GND plane attached to the device to the GND planes on other layers. This has the added benefit of improving thermal conductivity from the device to the board.
6. BGA landing pads for a 0.8 mm pitch flip-chip BGA are typically 0.4 mm in diameter (exposed). The actual size of the copper pad will depend on whether solder-mask-defined (SMD) or non-solder-mask-defined solder land pads are used. For more information, refer to TI's Surface Mount Technology (SMT) References at <http://focus.ti.com/quality/docs> under the "Quality and Lead (Pb)-Free Data" menu.
7. If vias are used for the high-speed signals, ground via should be implemented adjacent to the signal via to provide return path and isolation. For differential pair, the typical via configuration is "ground-signal-signal-ground."

11.2 Layout Example

The following example layout demonstrates how all signals can be escaped from the BGA array using stripline routing on a generic 28-layer stackup. This example layout assumes the following:

- Trace width: 0.127 mm (5 mil)
- Trace edge-to-edge spacing: 0.152 mm (6 mil)
- VIA finished hole size (diameter): 0.203 mm (8 mil)
- VIA drilled hole size: 0.254 mm (10 mil)
- VIA-to-VIA spacing: 1.0 mm (39 mil), to enhance PCB manufacturability
- No VIA-in-pad used

Note that many other escape routing options exist using different trace width and spacing combinations. The optimum trace width and spacing will depend on the PCB material, PCB routing density, and other factors.

Layout Example (continued)

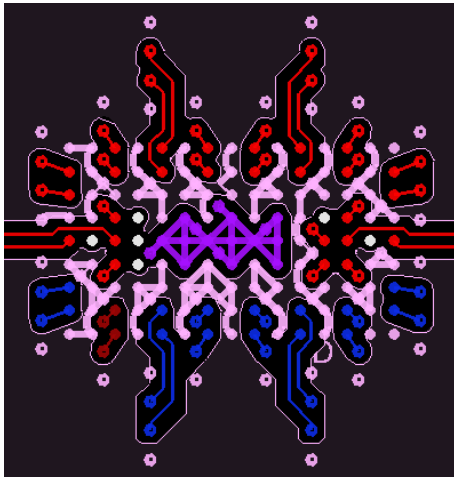

Figure 22. Top Layer

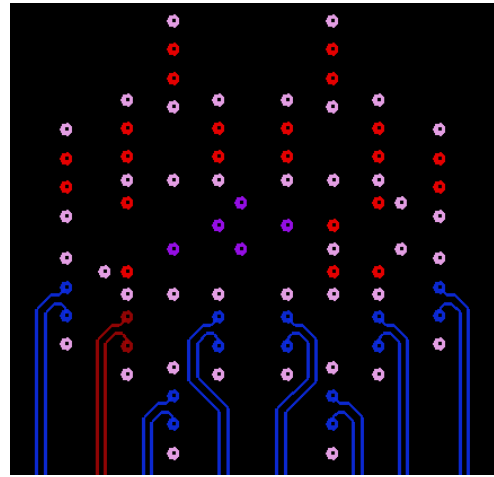

Figure 23. Internal Signal Layer 1

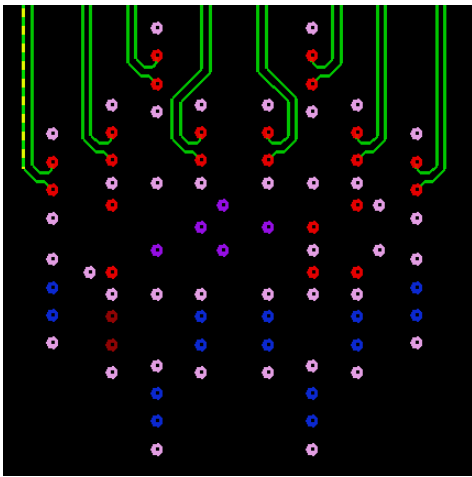

Figure 24. Internal Signal Layer 2

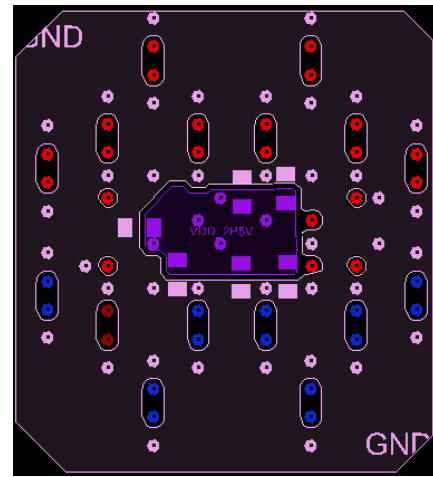

Figure 25. Bottom Layer

12 Device and Documentation Support

12.1 Documentation Support

12.1.1 Related Documentation

For related documentation see the following:

- Texas Instruments, [25G/28G Retimer Programmer's Guide](#)
- Texas Instruments, [DS280DF810EVM User's Guide](#)
- Texas Instruments, [Understanding EEPROM Programming for 25G and 28G Repeaters and Retimers Application Report](#)
- Texas Instruments, [Implementation of TI 25G/28G Retimers for CPRI-7 Applications Application Report](#)
- Texas Instruments, [DS2X0DF810 Adaption Parameters Optimization Proceed Application Report](#)
- Texas Instruments, [DS2X0DFX10 25Gbps/28Gbps Retimer Functional Guide Application Report](#)
- Texas Instruments, [25G/28G Retimer CDR Lock Optimization for Outlier Data Rate PPM Check Scenario Application Report](#)
- Texas Instruments, [Implementation of TI 25G/28G Retimers for OTU4 Applications Application Report](#)
- Texas Instruments, [Selection Guide for TI 25G and 28G Retimers and Repeaters Application Report](#)

Click [here](#) to request access the Programmers Guide in the DS280DF810 MySecure folder.

12.2 Receiving Notification of Documentation Updates

To receive notification of documentation updates, navigate to the device product folder on ti.com. In the upper right corner, click on *Alert me* to register and receive a weekly digest of any product information that has changed. For change details, review the revision history included in any revised document.

12.3 Support Resources

[TI E2E™ support forums](#) are an engineer's go-to source for fast, verified answers and design help — straight from the experts. Search existing answers or ask your own question to get the quick design help you need.

Linked content is provided "AS IS" by the respective contributors. They do not constitute TI specifications and do not necessarily reflect TI's views; see TI's [Terms of Use](#).

12.4 Trademarks

E2E is a trademark of Texas Instruments.

All other trademarks are the property of their respective owners.

12.5 Electrostatic Discharge Caution



This integrated circuit can be damaged by ESD. Texas Instruments recommends that all integrated circuits be handled with appropriate precautions. Failure to observe proper handling and installation procedures can cause damage.

ESD damage can range from subtle performance degradation to complete device failure. Precision integrated circuits may be more susceptible to damage because very small parametric changes could cause the device not to meet its published specifications.

12.6 Glossary

[SLYZ022](#) — *TI Glossary*.

This glossary lists and explains terms, acronyms, and definitions.

PACKAGING INFORMATION

Orderable Device	Status (1)	Package Type	Package Drawing	Pins	Package Qty	Eco Plan (2)	Lead/Ball Finish (6)	MSL Peak Temp (3)	Op Temp (°C)	Device Marking (4/5)	Samples
DS280DF810ABVR	ACTIVE	FCBGA	ABV	135	1000	Green (RoHS & no Sb/Br)	SNAGCU	Level-3-260C-168 HR	-40 to 85	DS280DF8	Samples
DS280DF810ABVT	ACTIVE	FCBGA	ABV	135	250	Green (RoHS & no Sb/Br)	SNAGCU	Level-3-260C-168 HR	-40 to 85	DS280DF8	Samples
DS280DF810ABWR	ACTIVE	FCBGA	ABW	135	1000	Green (RoHS & no Sb/Br)	SNAGCU	Level-3-260C-168 HR	-40 to 85	DS280DF8W	Samples
DS280DF810ABWT	ACTIVE	FCBGA	ABW	135	250	Green (RoHS & no Sb/Br)	SNAGCU	Level-3-260C-168 HR	-40 to 85	DS280DF8W	Samples

(1) The marketing status values are defined as follows:

ACTIVE: Product device recommended for new designs.

LIFEBUY: TI has announced that the device will be discontinued, and a lifetime-buy period is in effect.

NRND: Not recommended for new designs. Device is in production to support existing customers, but TI does not recommend using this part in a new design.

PREVIEW: Device has been announced but is not in production. Samples may or may not be available.

OBSOLETE: TI has discontinued the production of the device.

(2) **RoHS:** TI defines "RoHS" to mean semiconductor products that are compliant with the current EU RoHS requirements for all 10 RoHS substances, including the requirement that RoHS substance do not exceed 0.1% by weight in homogeneous materials. Where designed to be soldered at high temperatures, "RoHS" products are suitable for use in specified lead-free processes. TI may reference these types of products as "Pb-Free".

RoHS Exempt: TI defines "RoHS Exempt" to mean products that contain lead but are compliant with EU RoHS pursuant to a specific EU RoHS exemption.

Green: TI defines "Green" to mean the content of Chlorine (Cl) and Bromine (Br) based flame retardants meet JS709B low halogen requirements of <=1000ppm threshold. Antimony trioxide based flame retardants must also meet the <=1000ppm threshold requirement.

(3) MSL, Peak Temp. - The Moisture Sensitivity Level rating according to the JEDEC industry standard classifications, and peak solder temperature.

(4) There may be additional marking, which relates to the logo, the lot trace code information, or the environmental category on the device.

(5) Multiple Device Markings will be inside parentheses. Only one Device Marking contained in parentheses and separated by a "-" will appear on a device. If a line is indented then it is a continuation of the previous line and the two combined represent the entire Device Marking for that device.

(6) Lead/Ball Finish - Orderable Devices may have multiple material finish options. Finish options are separated by a vertical ruled line. Lead/Ball Finish values may wrap to two lines if the finish value exceeds the maximum column width.

Important Information and Disclaimer: The information provided on this page represents TI's knowledge and belief as of the date that it is provided. TI bases its knowledge and belief on information provided by third parties, and makes no representation or warranty as to the accuracy of such information. Efforts are underway to better integrate information from third parties. TI has taken and

continues to take reasonable steps to provide representative and accurate information but may not have conducted destructive testing or chemical analysis on incoming materials and chemicals. TI and TI suppliers consider certain information to be proprietary, and thus CAS numbers and other limited information may not be available for release.

In no event shall TI's liability arising out of such information exceed the total purchase price of the TI part(s) at issue in this document sold by TI to Customer on an annual basis.

TAPE AND REEL INFORMATION

QUADRANT ASSIGNMENTS FOR PIN 1 ORIENTATION IN TAPE

*All dimensions are nominal

Device	Package Type	Package Drawing	Pins	SPQ	Reel Diameter (mm)	Reel Width W1 (mm)	A0 (mm)	B0 (mm)	K0 (mm)	P1 (mm)	W (mm)	Pin1 Quadrant
DS280DF810ABVR	FCBGA	ABV	135	1000	330.0	24.4	8.4	13.4	3.0	12.0	24.0	Q2
DS280DF810ABVT	FCBGA	ABV	135	250	178.0	24.4	8.4	13.4	3.0	12.0	24.0	Q2
DS280DF810ABWR	FCBGA	ABW	135	1000	330.0	24.4	8.4	13.4	3.0	12.0	24.0	Q2
DS280DF810ABWT	FCBGA	ABW	135	250	178.0	24.4	8.4	13.4	3.0	12.0	24.0	Q2

TAPE AND REEL BOX DIMENSIONS

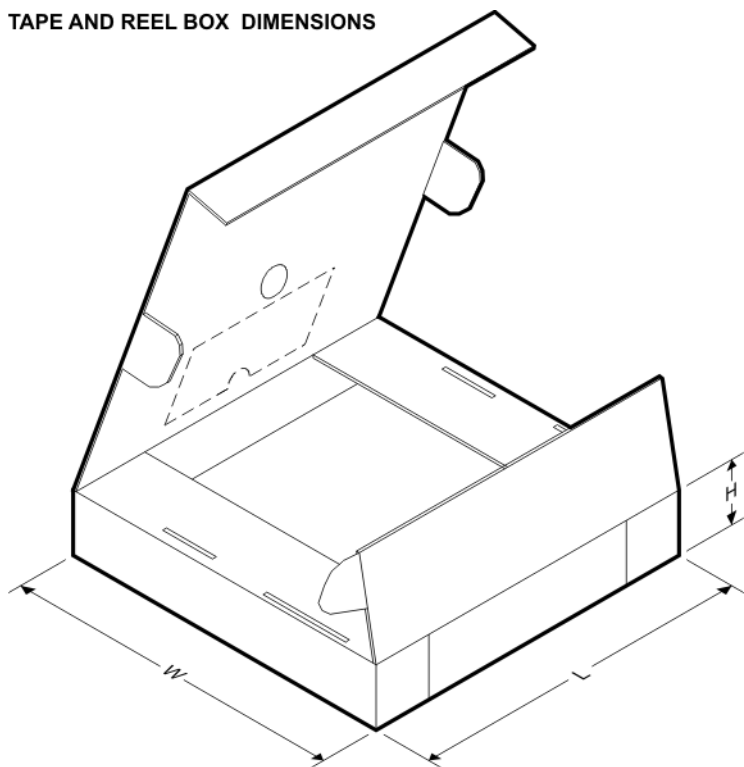

*All dimensions are nominal

Device	Package Type	Package Drawing	Pins	SPQ	Length (mm)	Width (mm)	Height (mm)
DS280DF810ABVR	FCBGA	ABV	135	1000	367.0	367.0	45.0
DS280DF810ABVT	FCBGA	ABV	135	250	213.0	191.0	55.0
DS280DF810ABWR	FCBGA	ABW	135	1000	367.0	367.0	45.0
DS280DF810ABWT	FCBGA	ABW	135	250	213.0	191.0	55.0

EXAMPLE BOARD LAYOUT

ABV0135A

FCBGA - 2.51 mm max height

BALL GRID ARRAY

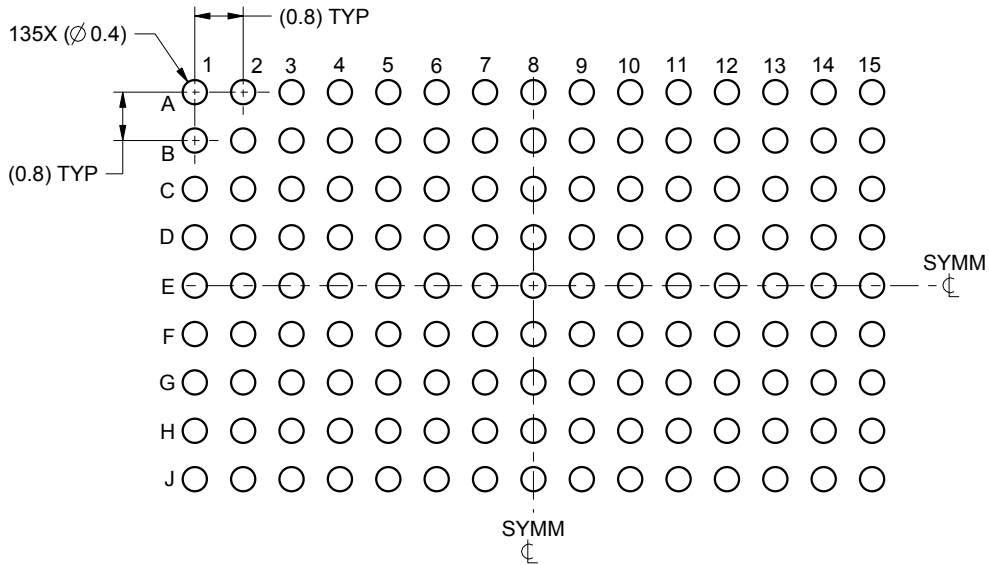

LAND PATTERN EXAMPLE
SCALE:8X

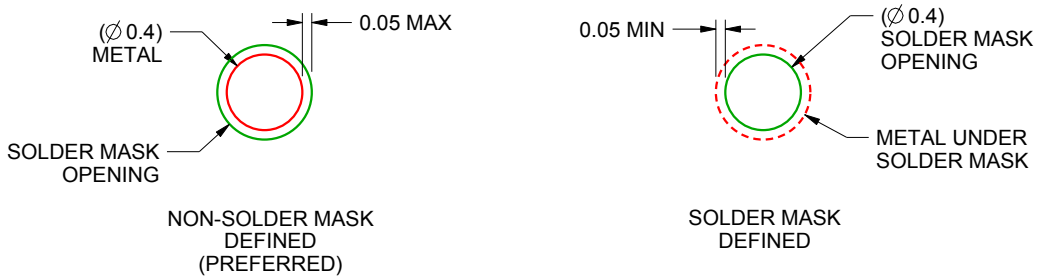

SOLDER MASK DETAILS
NOT TO SCALE

4221740/B 02/2016

NOTES: (continued)

- Final dimensions may vary due to manufacturing tolerance considerations and also routing constraints. For information, see Texas Instruments literature number SPRU811 (www.ti.com/lit/spru811).

EXAMPLE STENCIL DESIGN

ABV0135A

FCBGA - 2.51 mm max height

BALL GRID ARRAY

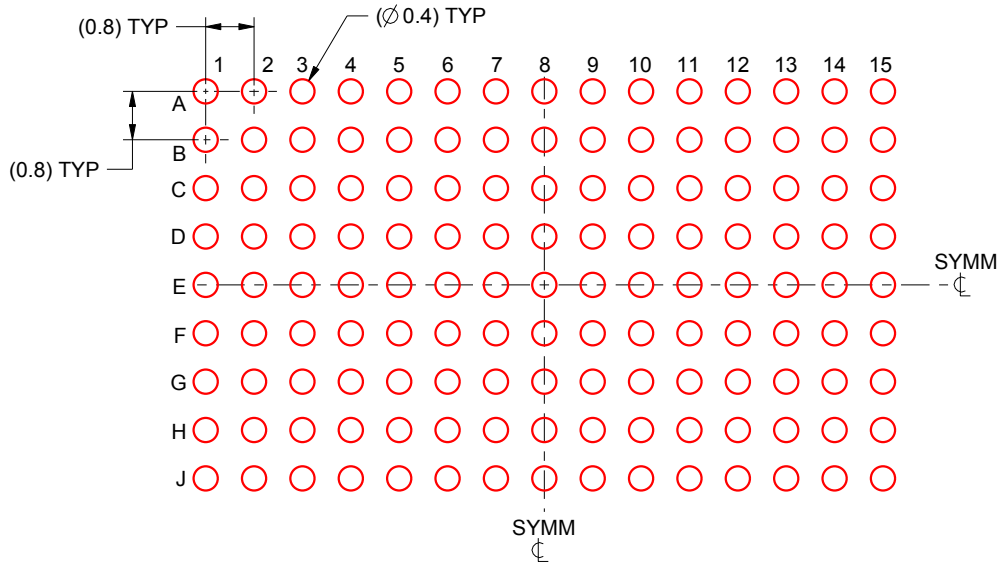

SOLDER PASTE EXAMPLE
BASED ON 0.15 mm THICK STENCIL
SCALE:8X

4221740/B 02/2016

NOTES: (continued)

4. Laser cutting apertures with trapezoidal walls and rounded corners may offer better paste release.

IMPORTANT NOTICE AND DISCLAIMER

TI PROVIDES TECHNICAL AND RELIABILITY DATA (INCLUDING DATASHEETS), DESIGN RESOURCES (INCLUDING REFERENCE DESIGNS), APPLICATION OR OTHER DESIGN ADVICE, WEB TOOLS, SAFETY INFORMATION, AND OTHER RESOURCES "AS IS" AND WITH ALL FAULTS, AND DISCLAIMS ALL WARRANTIES, EXPRESS AND IMPLIED, INCLUDING WITHOUT LIMITATION ANY IMPLIED WARRANTIES OF MERCHANTABILITY, FITNESS FOR A PARTICULAR PURPOSE OR NON-INFRINGEMENT OF THIRD PARTY INTELLECTUAL PROPERTY RIGHTS.

These resources are intended for skilled developers designing with TI products. You are solely responsible for (1) selecting the appropriate TI products for your application, (2) designing, validating and testing your application, and (3) ensuring your application meets applicable standards, and any other safety, security, or other requirements. These resources are subject to change without notice. TI grants you permission to use these resources only for development of an application that uses the TI products described in the resource. Other reproduction and display of these resources is prohibited. No license is granted to any other TI intellectual property right or to any third party intellectual property right. TI disclaims responsibility for, and you will fully indemnify TI and its representatives against, any claims, damages, costs, losses, and liabilities arising out of your use of these resources.

TI's products are provided subject to TI's Terms of Sale (www.ti.com/legal/termsofsale.html) or other applicable terms available either on ti.com or provided in conjunction with such TI products. TI's provision of these resources does not expand or otherwise alter TI's applicable warranties or warranty disclaimers for TI products.

Mailing Address: Texas Instruments, Post Office Box 655303, Dallas, Texas 75265
Copyright © 2020, Texas Instruments Incorporated