

## Getting started with the P-NUCLEO-IKA02A1 STM32 Nucleo pack for electrochemical toxic gas sensor expansion board with CO sensor

### Introduction

The P-NUCLEO-IKA02A1 evaluation pack provides a reference design for various electrochemical sensors.

The STM32 Nucleo gas expansion board interfaces electrochemical sensors with the MCU on the STM32 Nucleo development board. Two TSU111 operational amplifiers provide signal conditioning; they are ideal for electrochemical sensing thanks to their high precision and low power consumption. The expansion board includes an ultra-low current precision analog temperature sensor STLM20 used for compensation of gas readings.

STM32 Nucleo boards provide an affordable and flexible way for users to experiment with new ideas and build prototypes with any STM32 microcontroller line. The NUCLEO-L053R8 is designed for low power applications.

The design and componentry are optimized for battery operation and maximum battery life time.

Figure 1: P-NUCLEO-IKA02A1 evaluation pack

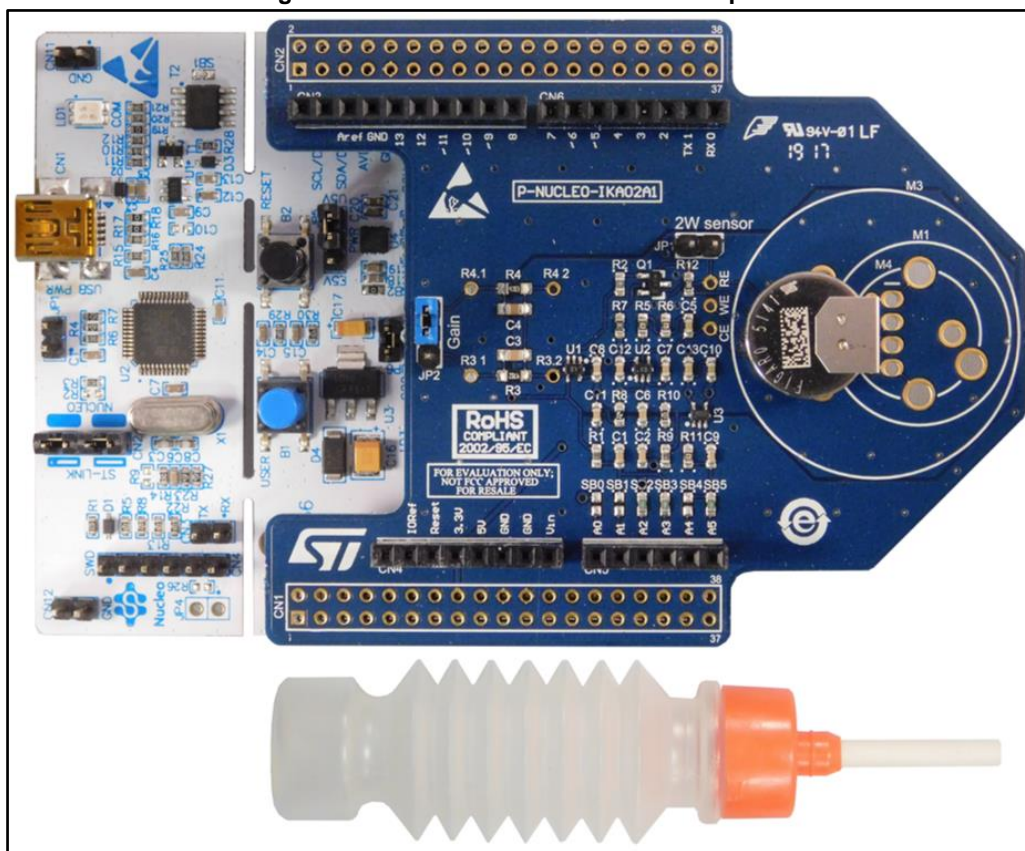

**Contents**

**1 Getting started ..... 5**

    1.1 Evaluation pack overview ..... 5

    1.2 Electrochemical gas sensors ..... 5

    1.3 P-NUCLEO-IKA02A1 expansion board ..... 6

        1.3.1 Jumper settings ..... 7

        1.3.2 Solder bridges ..... 7

**2 Gas signal conditioning ..... 9**

**3 Using the board ..... 10**

    3.1 Reading data ..... 10

    3.2 Carbon monoxide application ..... 11

    3.3 Unicleo application ..... 11

**4 Schematic diagrams ..... 13**

**5 Bill of materials ..... 14**

**6 Revision history ..... 17**

---

## List of tables

|   |    |
|---|----|
| Table 1: JP1 jumper settings .....                                | 7  |
| Table 2: JP2 jumper description .....                             | 7  |
| Table 3: Compatibility table .....                                | 8  |
| Table 4: P-NUCLEO-IKA02A1 expansion board bill of materials ..... | 14 |
| Table 5: Document revision history .....                          | 17 |

---

## List of figures

|   |    |
|---|----|
| Figure 1: P-NUCLEO-IKA02A1 evaluation pack .....  | 1  |
| Figure 2: Carbon monoxide electrochemical sensor .....  | 6  |
| Figure 3: Carbon monoxide electrochemical sensor .....  | 6  |
| Figure 4: Configuration of solder bridges.....  | 7  |
| Figure 5: P-NUCLEO-IKA02A1 expansion board: gas signal conditioning schematic diagram.....                    | 9  |
| Figure 6: P-NUCLEO-IKA02A1 expansion board connected to Tera Term: firmware output with no gas presence ..... | 10 |
| Figure 7: P-NUCLEO-IKA02A1 expansion board connected to Tera Term: sensitivity setup.....                     | 10 |
| Figure 8: P-NUCLEO-IKA02A1 expansion board: carbon monoxide extraction and application .....                  | 11 |
| Figure 9: Unicleo Custom Fields window.....   | 11 |
| Figure 10: P-NUCLEO-IKA02A1 expansion board schematic diagram .....   | 13 |

# 1 Getting started

## 1.1 Evaluation pack overview

The P-NUCLEO-IKA02A1 evaluation pack targets a segment of CO detectors for home alarm systems. It is designed to be easily customized and meets EN50291 requirements.

It features:

- STM32 Nucleo gas expansion board
  - compatible with most electrochemical sensors
  - four different footprints for sensors (PCD13,5, PCD17, Mini and TGS5141)
  - two-, three- and four-electrode sensors
  - signal conditioning with TSU111
  - STLM20 temperature sensor
  - changeable gain
- NUCLEO-L053R8
  - Ultra-low-power ARM® Cortex®-M0+ MCU (32 MHz max.) with 64 Kbytes Flash and 8 Kbytes of SRAM
- Carbon monoxide sensor
  - Figaro TGS5141
  - coin-cell sensor
  - expected life time > 10 yrs
  - can pass 5000 ppm EN50291
- Low power design for long battery life
- RoHS compliant

## 1.2 Electrochemical gas sensors

The P-NUCLEO-IKA02A1 expansion board interfaces electrochemical sensors with the MCU on the STM32 Nucleo development board.

Electrochemical gas sensors help detect toxic gases like CO, SO<sub>2</sub>, NO and CL<sub>2</sub>.

Specifically, the P-NUCLEO-IKA02A1 evaluation pack features the carbon monoxide sensor (Figaro TGS5141), which acts as a fuel cell.

It contains two or three electrodes, electrolyte and gas membrane: the detected gas is oxidized or reduced on the working electrode and a small amount of current is generated (from a few nA to hundreds of nA per ppm of gas concentration).

Depending on the process of oxidization or reduction, the generated current can be positive or negative. The sensors also require some bias voltage to be applied between the working electrode (WE) and the reference electrode (RE) (see [Section 2: "Gas signal conditioning"](#))<sup>a</sup>.

---

<sup>a</sup> For further details on sensors and signal conditioning refer to AN4348: "Signal conditioning for electrochemical sensors" on [www.st.com](http://www.st.com).

Figure 2: Carbon monoxide electrochemical sensor

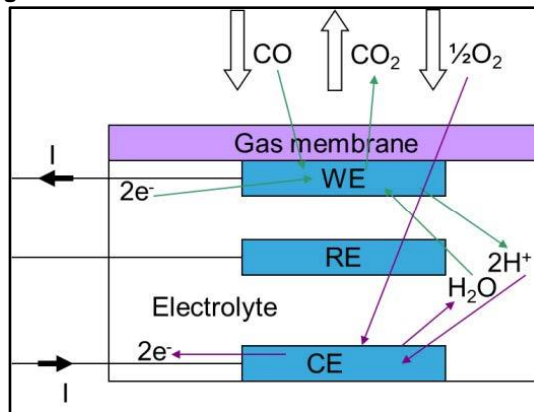

### 1.3 P-NUCLEO-IKA02A1 expansion board

The P-NUCLEO-IKA02A1 expansion board is compatible with the STM32 Nucleo board family thanks to the Arduino™ UNO R3 connectors. It is recommended to stack it on NUCLEO-L053R8, NUCLEO-F401RE or NUCLEO-L476RG boards.<sup>a</sup>

The expansion board is composed of three main blocks:

- Carbon monoxide sensor: Figaro TGS5141
- TSU111 operational amplifiers for signal conditioning
- STLM20 analog temperature precision sensor for temperature compensation

Figure 3: Carbon monoxide electrochemical sensor

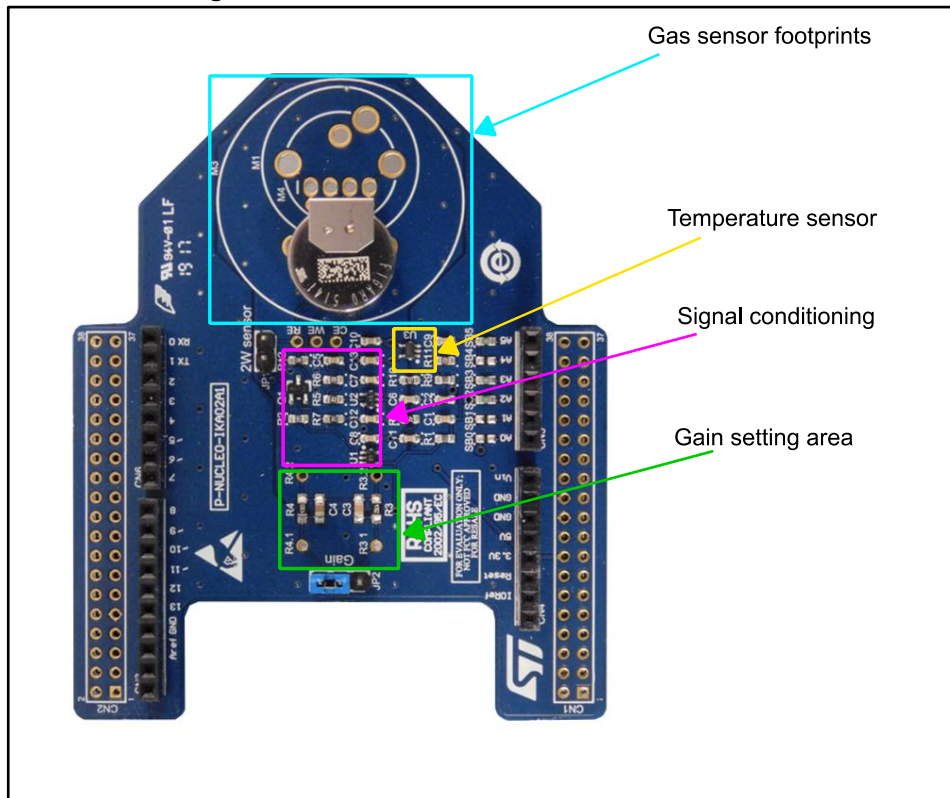

<sup>a</sup> More information can be found at <http://www.st.com/stm32nucleo>.

### 1.3.1 Jumper settings

The P-NUCLEO-IKA02A1 expansion board can use electrochemical sensors with 2, 3 or 4 wires.

To provide the right reference and bias value, set jumper JP1 as shown in the table below.

**Table 1: JP1 jumper settings**

| Sensor type  | JP1 jumper     |
|--------------|----------------|
| 2 wires      | Shorted        |
| 3 or 4 wires | Open           |
| TGS5141      | Doesn't matter |

Every electrochemical sensor produces a different amount of current. Therefore the expansion board embeds a gain setting area to change the gain through JP2 jumper.

The following table shows the default configuration.

**Table 2: JP2 jumper description**

| Position             | Gain  | Capacitor value | Max. sensor current |
|----------------------|-------|-----------------|---------------------|
| Pins 1 and 2 shorted | 47 k  | 100 n           | 60 $\mu$ A          |
| Pins 2 and 3 shorted | 470 k | 1 $\mu$         | 6 $\mu$ A           |

Additionally gain can be adjusted by replacing R4/C4 and R3/C3 with standard parts in a 0805 package.

It is also possible to place the THT resistor in R4.1/R4.2 and R3.1/R3.2 test points.

### 1.3.2 Solder bridges

The P-NUCLEO-IKA02A1 expansion board is compatible with most X-NUCLEO expansion boards. See the following figure and table for configuration and compatibility information, respectively.

**Figure 4: Configuration of solder bridges**

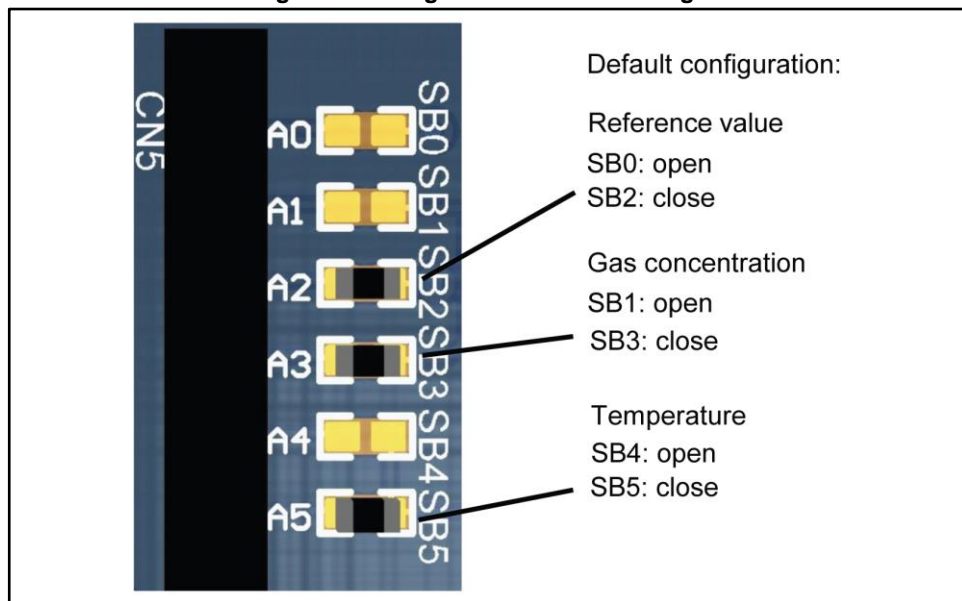

Table 3: Compatibility table

| Expansion board  | Reference              | Gas reading            | Temperature                     |
|------------------|------------------------|------------------------|---------------------------------|
| X-NUCLEO-IDB0xA1 | Default                | Default                | Default                         |
| X-NUCLEO-IDW01M1 | Default <sup>(1)</sup> | Default                | Default                         |
| X-NUCLEO-IDS01Ax | Default <sup>(2)</sup> | Default <sup>(2)</sup> | Default <sup>(2)</sup>          |
| X-NUCLEO-IKS01Ax | Default <sup>(3)</sup> | Default <sup>(3)</sup> | Not used/Default <sup>(3)</sup> |
| X-NUCLEO-IKA01A1 | Alternative            | Default                | Default                         |
| STEVAL-FKI868V1  | Default <sup>(4)</sup> | Default <sup>(4)</sup> | Default <sup>(4)</sup>          |

**Notes:**

<sup>(1)</sup>Alternative connection of GPIO13 of Wi-Fi module cannot be used

<sup>(2)</sup>Optional SPI connection and GPIO pins of SPSGRF module cannot be used

<sup>(3)</sup>Limited usage of INT on DIL24 and DRDY – see schematic pack and used alternative configuration. It is possible to use humidity sensor on board to provide temperature and humidity compensation

<sup>(4)</sup>S2-LP GPIO pins cannot be used; R14 and R15 must be removed.



## 2 Gas signal conditioning

The current generated by electrochemical sensors is transferred to the voltage by the U1 operational amplifier connected as a transimpedance amplifier. The gain of the amplifier is set by R4 and R3.

To prevent the operational amplifier U1 from being in low saturation (no presence of gas) the reference voltage is used:  $V_{REF}$  is 430 mV but can be altered by changing R8 and R10 resistors.

If  $V_{REF}$  is shifted close to  $V_{CC}$ , the electrochemical sensors with negative sensitivity (i.e.  $CL_2$  and  $NO_2$  sensors) can be used.

The sensors produce current in the order of nano amps and every leakage affects measurement. Therefore, the guarding ring connected to  $V_{REF}$  is made around the reference (RE) and working (WE) electrode; there is no current leakage as the potential difference among WE, RE and  $V_{REF}$  is 0 V.

The transimpedance amplifier is not able to keep sensors biased during power-off. Therefore, the Q1 transistor, which shorts the sensor during power-off, is added to protect the sensor against polarization.

**Figure 5: P-NUCLEO-IKA02A1 expansion board: gas signal conditioning schematic diagram**

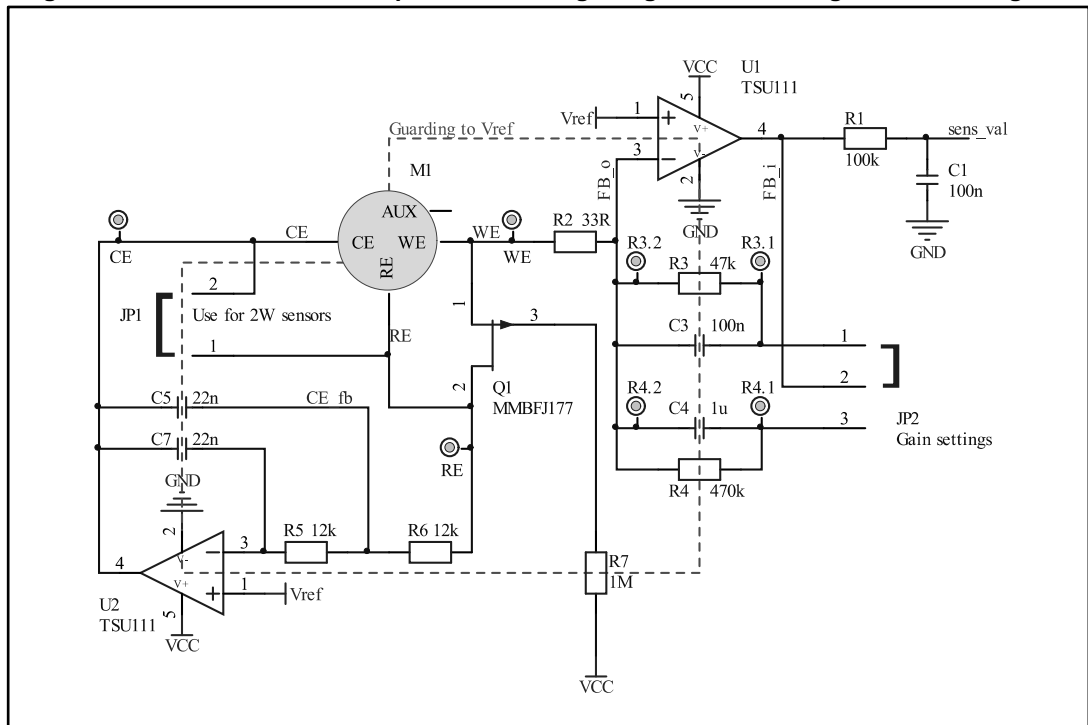

## 3 Using the board

### 3.1 Reading data

The P-NUCLEO-IKA02A1 expansion board is pre-programmed with basic firmware and calibration values stored in the Flash memory.

To read these data, you only have to connect the board to the PC with installed drivers for STM32 Nucleo boards ([STSW-LINK009](#)) and a terminal application.

Once the virtual COM port is detected, you can open it by setting up 115200 baud rate, 8 bits and no parity.

**Figure 6: P-NUCLEO-IKA02A1 expansion board connected to Tera Term: firmware output with no gas presence**

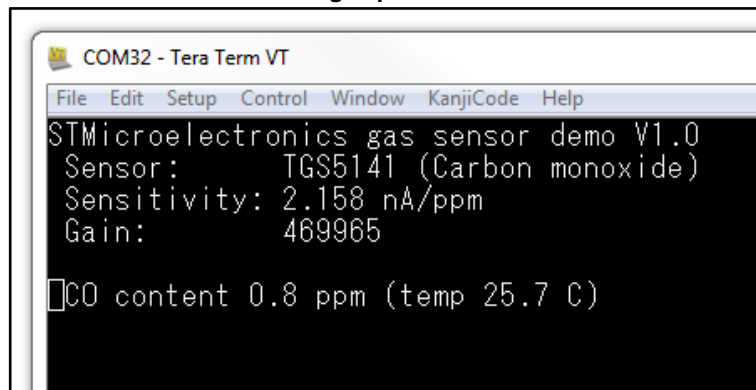

```

COM32 - Tera Term VT
File Edit Setup Control Window KanjiCode Help
STMicroelectronics gas sensor demo V1.0
Sensor:      TGS5141 (Carbon monoxide)
Sensitivity: 2.158 nA/ppm
Gain:        469965
[ ]CO content 0.8 ppm (temp 25.7 C)
  
```

The P-NUCLEO-IKA02A1 board can host different sensor types and the user can modify the gain.

The default application allows changing the sensitivity, gain and new value storage in the Flash memory.

The dialog can be invoked by sending “s” to adjust the sensitivity or “g” to adjust the gain.

**Figure 7: P-NUCLEO-IKA02A1 expansion board connected to Tera Term: sensitivity setup**

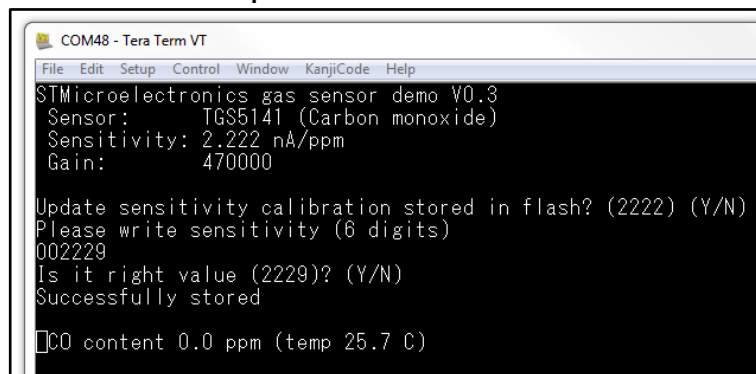

```

COM48 - Tera Term VT
File Edit Setup Control Window KanjiCode Help
STMicroelectronics gas sensor demo V0.3
Sensor:      TGS5141 (Carbon monoxide)
Sensitivity: 2.222 nA/ppm
Gain:        470000
Update sensitivity calibration stored in flash? (2222) (Y/N)
Please write sensitivity (6 digits)
002229
Is it right value (2229)? (Y/N)
Successfully stored
[ ]CO content 0.0 ppm (temp 25.7 C)
  
```

The source code for NUCLEO-L053R8, NUCLEO-F401RE and NUCLEO-L476RG boards is available in the X-CUBE-IKA02A1 software package as **Gas concentration reading** sample.

### 3.2 Carbon monoxide application

To test the P-NUCLEO-IKA02A1 expansion board with real carbon monoxide, the gas sampling pump is included in the P-NUCLEO-IKA02A1 expansion kit.

The easiest way to test functionality is to extract CO from the flame of a lighter using the pump with a ceramic nozzle and applying it to the sensor.



The nozzle has to be made of ceramic to be put directly into the flame otherwise no CO will be extracted.

Once the CO is applied to the sensor, the value shown in the terminal should rapidly rise.

Figure 8: P-NUCLEO-IKA02A1 expansion board: carbon monoxide extraction and application

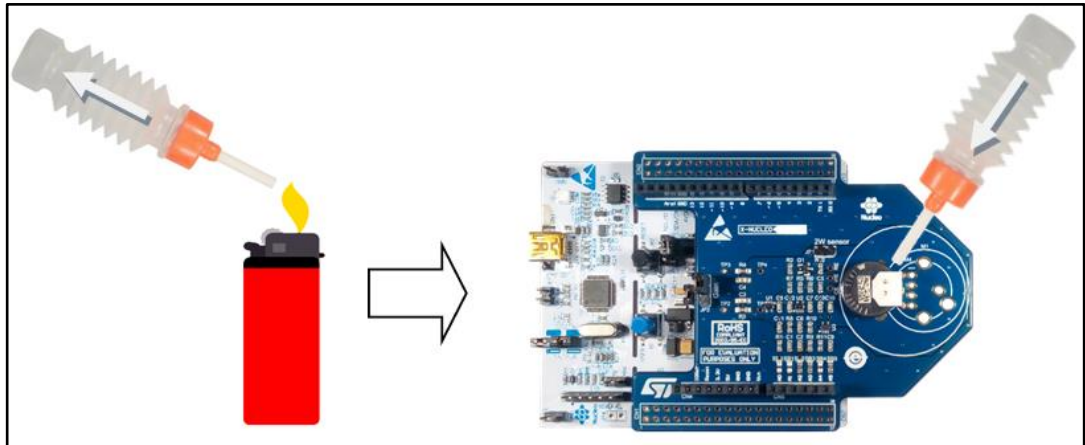

### 3.3 Unicleo application

The ST GUI application, Unicleo, available at [www.st.com](http://www.st.com), contains a **Custom Fields** window which fully supports the P-NUCLEO-IKA02A1 expansion board to show the measured values in a graph.

Figure 9: Unicleo Custom Fields window

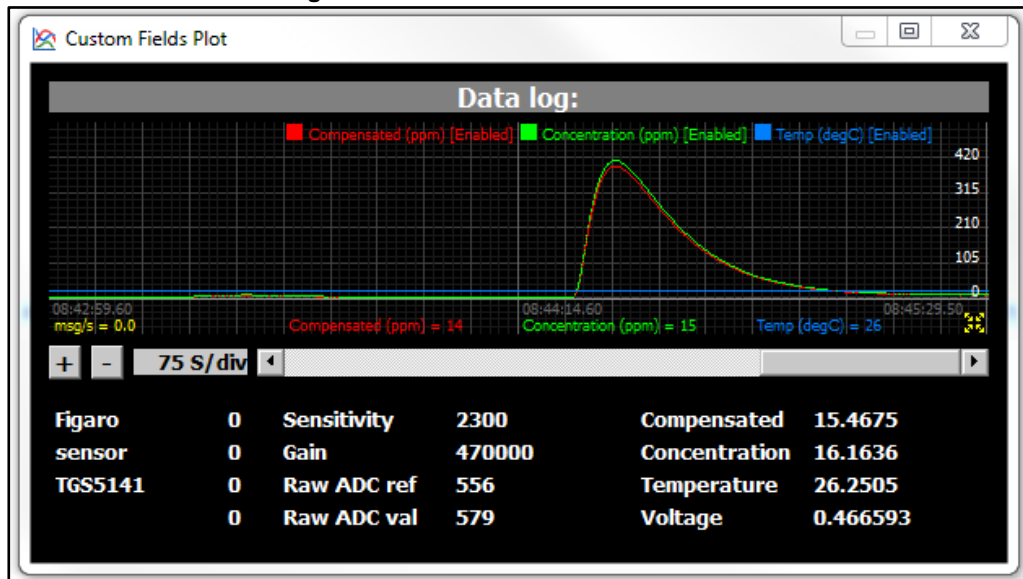

---

The source code for NUCLEO-L053R8, NUCLEO-F401RE and NUCLEO-L476RG boards is available in the X-CUBE-IKA02A1 software package as **DataLogCustomLite** sample.

# 4 Schematic diagrams

Figure 10: P-NUCLEO-IKA02A1 expansion board schematic diagram

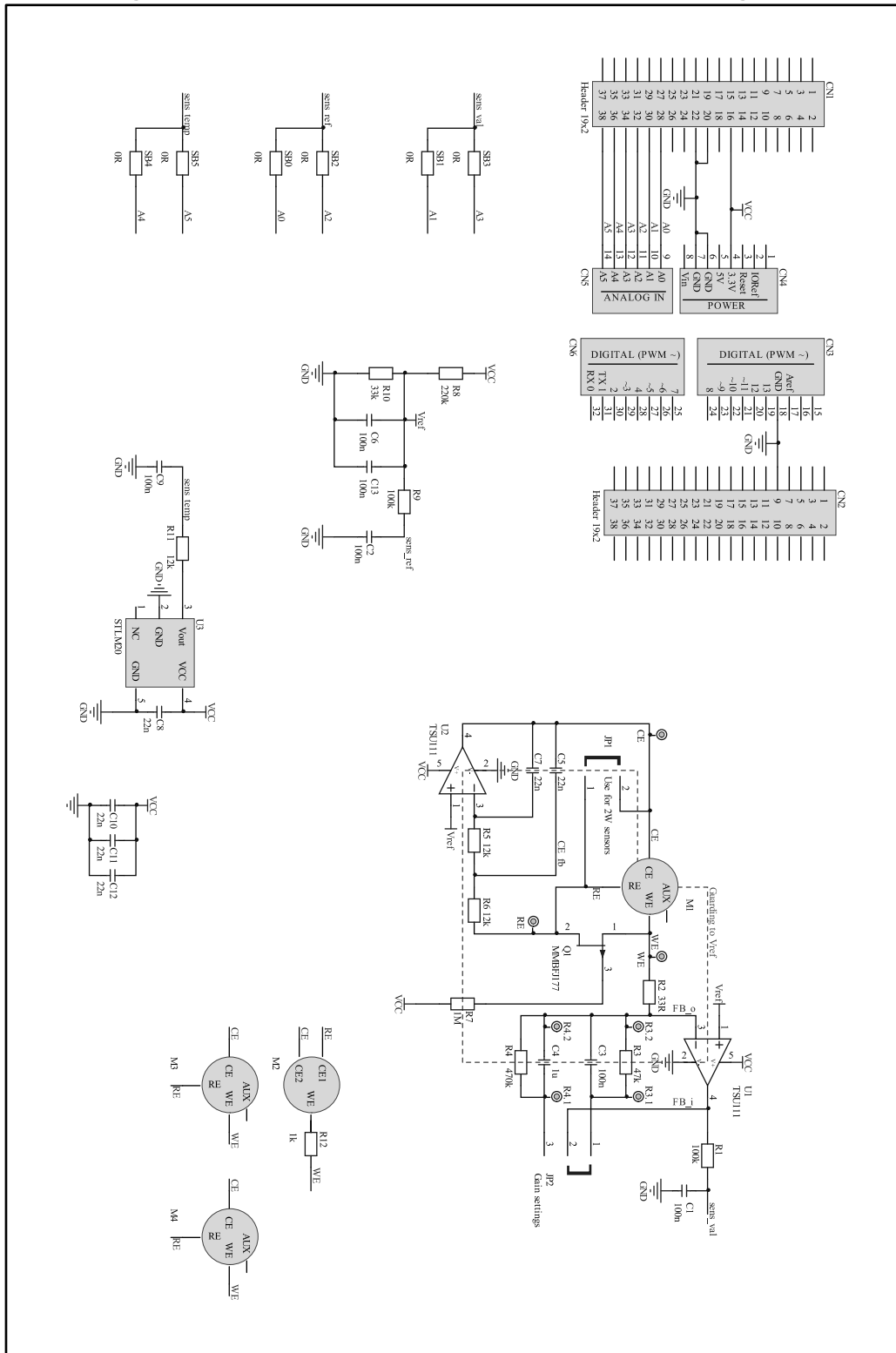

## 5 Bill of materials

Table 4: P-NUCLEO-IKA02A1 expansion board bill of materials

| Item | Q.ty | Ref.                            | Part/Value  | Description  | Manufacturer       | Order code     |
|------|------|---------------------------------|---|--|--------------------|----------------|
| 1    | 2    | U1,<br>U2                       | AOP-<br>5PINS,<br>SC-70-5,<br>SMD   | Operational amplifier                                    | ST                 | TSU111ICT      |
| 2    | 1    | U3                              | SC-70-5,<br>SMD   | Temperature sensor                                       | ST                 | STLM20W87F     |
| 3    | 1    | CN3                             | Socket<br>1x10, THT   | Arduino Uno Digi 2                                       | Samtec             | SSQ-110-03-F-S |
| 4    | 1    | CN4                             | Socket<br>1x8, THT  | Arduino Uno Power  | Samtec             | SSQ-108-03-F-S |
| 5    | 1    | CN6                             | Socket<br>1x8, THT  | Arduino Uno Digi 1                                       | Samtec             | SSQ-108-03-F-S |
| 6    | 1    | CN5                             | Socket<br>1x6, THT  | Arduino UNO Analog                                       | Samtec             | SSQ-106-03-G-S |
|      |      |                                 |   |  |                    | SQ-106-03-F-S  |
| 7    | 1    | Q1                              | SOT-23,<br>SMD  | P-channel silicon<br>junction field-effect<br>transistor | Fairchild          | MMBFJ177       |
| 8    | 1    | JP1                             | Header<br>1x2, THT  | Jumper   | TE<br>Connectivity | 77311-401-36LF |
| 9    | 1    | JP2                             | Header<br>1x3, THT  | Jumper   | TE<br>Connectivity | 77311-401-36LF |
| 10   | 3    | SB2,<br>SB3,<br>SB5             | 0 R, 50 V,<br>100 mW,<br>0603_SB,<br>SMD  | Resistors  |                    |                |
| 11   | 2    | R1,<br>R9                       | 50 V, 100<br>mW, 100<br>k, $\pm 1\%$ ,<br>$\pm 100$<br>ppm/K,<br>0603_R,<br>SMD | Resistors  |                    |                |
| 12   | 5    | C1,<br>C2,<br>C6,<br>C9,<br>C13 | 100 n, 50<br>V, X7R,<br>$\pm 10\%$ ,<br>0603_C,<br>SMD                          | Capacitors   |                    |                |
| 13   | 1    | C3                              | 100 n, 50<br>V, X7R,<br>$\pm 10\%$ ,<br>0805_C,<br>SMD                          | Capacitor  |                    |                |

| Item | Q.ty | Ref.                                     | Part/Value  | Description | Manufacturer | Order code |
|------|------|--|---|-------------|--------------|------------|
| 14   | 3    | R5,<br>R6,<br>R11                        | 12 k, 50 V,<br>100 mW,<br>±1%, ±100<br>ppm/K,<br>0603_R,<br>SMD     | Resistors   |              |            |
| 15   | 1    | R12                                      | 1 k, 50 V,<br>100 mW,<br>±1%, ±100<br>ppm/K,<br>0603_R,<br>SMD      | Resistor    |              |            |
| 16   | 1    | R7                                       | 1 M, 50 V,<br>100 mW,<br>±1%, ±100<br>ppm/K,<br>0603_R,<br>SMD      | Resistor    |              |            |
| 17   | 1    | C4                                       | 1 $\mu$ , 50 V,<br>X7R,<br>±10%,<br>0805_C,<br>SMD                  | Capacitor   |              |            |
| 18   | 1    | R8                                       | 220 k, 50<br>V, 100<br>mW, ±1%,<br>±100<br>ppm/K,<br>0603_R,<br>SMD | Resistor    |              |            |
| 19   | 6    | C5,<br>C7,<br>C8,<br>C10,<br>C11,<br>C12 | 22 n, 50 V,<br>X7R,<br>±10%,<br>0603_C,<br>SMD                      | Capacitors  |              |            |
| 20   | 1    | R10                                      | 33 k, 50 V,<br>100 mW,<br>±1%, ±100<br>ppm/K,<br>0603_R,<br>SMD     | Resistor    |              |            |
| 21   | 1    | R2                                       | 33 R, 50<br>V, 100<br>mW, ±1%,<br>±100<br>ppm/K,<br>0603_R,<br>SMD  | Resistor    |              |            |

| Item | Q.ty | Ref. | Part/Value  | Description         | Manufacturer        | Order code    |
|------|------|------|---|---------------------|---------------------|---------------|
| 22   | 1    | R4   | 470 k, 50 V, 100 mW, $\pm 1\%$ , $\pm 100$ ppm/K, 0805_R, SMD | Resistor            |                     |               |
| 23   | 1    | R3   | 47 k, 50 V, 100 mW, $\pm 1\%$ , $\pm 100$ ppm/K, 0805_R, SMD  | Resistor            |                     |               |
| 24   | 1    | M2   | THT   | CO sensor           | Figaro              | TGS541        |
| 25   | 1    |      |   | Gas collection tool | New Cosmos Electric | CZ-163 CO     |
| 26   | 1    |      |   | STM32 Nucleo board  | ST                  | NUCLEO-L053R8 |



## 6 Revision history

Table 5: Document revision history

| Date        | Version | Changes   |
|-------------|---------|---|
| 26-Jun-2017 | 1       | Initial release.  |
| 23-Oct-2017 | 2       | Updated <a href="#">Section 1.3: "P-NUCLEO-IKA02A1 expansion board"</a> , <a href="#">Section 1.3.1: "Jumper settings"</a> , <a href="#">Section 1.3.2: "Solder bridges"</a> .<br>Added <a href="#">Section 3.1: "Reading data"</a> , <a href="#">Section 3.2: "Carbon monoxide application"</a> and <a href="#">Section 3.3: "Unicleo application"</a> |

**IMPORTANT NOTICE – PLEASE READ CAREFULLY**

STMicroelectronics NV and its subsidiaries ("ST") reserve the right to make changes, corrections, enhancements, modifications, and improvements to ST products and/or to this document at any time without notice. Purchasers should obtain the latest relevant information on ST products before placing orders. ST products are sold pursuant to ST's terms and conditions of sale in place at the time of order acknowledgement.

Purchasers are solely responsible for the choice, selection, and use of ST products and ST assumes no liability for application assistance or the design of Purchasers' products.

No license, express or implied, to any intellectual property right is granted by ST herein.

Resale of ST products with provisions different from the information set forth herein shall void any warranty granted by ST for such product.

ST and the ST logo are trademarks of ST. All other product or service names are the property of their respective owners.

Information in this document supersedes and replaces information previously supplied in any prior versions of this document.

© 2017 STMicroelectronics – All rights reserved