

LP8733xEVM and LP8732xEVM Evaluation Modules User Guide

This user's guide describes the characteristics, operation, and use of the LP8733xEVM and LP8732xEVM evaluation modules (EVM). This user's guide includes a schematic diagram and bill of materials (BOM).

	Caution	<p>Caution Hot surface.</p> <p>Contact may cause burns.</p> <p>Do not touch</p>
---	----------------	--

Contents

1	Related Documentation from Texas Instruments.....	2
2	FCC Warning	2
3	If You Need Assistance	2
1	Introduction	3
2	Setup	4
	2.1 Input/Output Connector Description	4
	2.2 Software Installation	4
	2.3 Power Supply Setup	5
	2.4 Notes on Efficiency Measurement Procedure.....	6
3	GUI Overview	6
	3.1 Main Tab	7
	3.2 Other Tabs and Menus.....	7
	3.3 Console	7
4	Board Layout	7
5	Evaluation Board Schematic	9
6	Bill of Materials	12

List of Figures

1	LP8733xEVM and LP8732xEVM	3
2	Evaluation Software GUI When EVM is Connected to the PC using USB Cable.....	5
3	Evaluation Software GUI Showing Steps Needed to Power up the LP8733xEVM and LP8732xEVM.....	6
4	LP8733xEVM and LP8732xEVM Board Layout	8
5	EVM Schematic	9
6	EVM Connectors	10
7	EVM I2C Interface.....	11

Trademarks

Windows is a registered trademark of Microsoft Corporation.
All other trademarks are the property of their respective owners.

1 Related Documentation from Texas Instruments

[LP8732xx data sheet](#) and [LP8733xx data sheet](#)

2 FCC Warning

This equipment is intended for use in a laboratory test environment only. It generates, uses, and can radiate radio frequency energy and has not been tested for compliance with the limits of computing devices pursuant to subpart J of part 15 of FCC rules, which are designed to provide reasonable protection against radio frequency interference. Operation of this equipment in other environments may cause interference with radio communications, in which case the user, at their own expense, will be required to take whatever measures may be required to correct this interference.

3 If You Need Assistance

Contact your local TI sales representative.

Using the LP8733xEVM and LP8732xEVM Evaluation Modules

1 Introduction

The Texas Instruments LP8733xEVM and LP8732xEVM evaluation modules (EVM) help designers evaluate the operation and performance of the LP8732xx and LP8733xx devices. The LP8733xEVM and LP8732xEVM are designed to meet the power-management requirements of the latest processor and platform needs in automotive camera and radar applications. These devices contain two step-down DC-DC converters, two linear regulators, and a general-purpose digital-output signal. The device is controlled by an I²C-compatible serial interface.

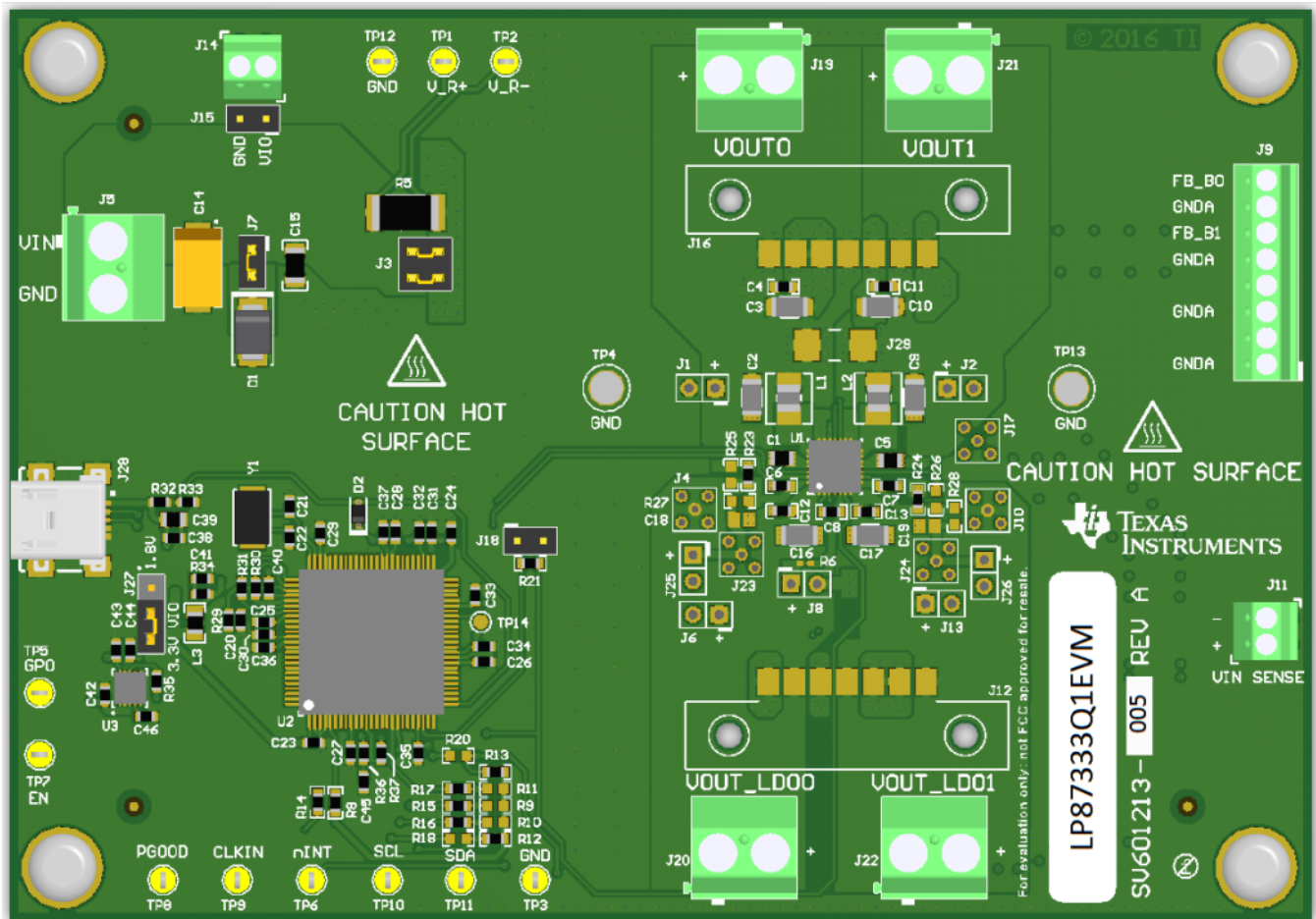

Figure 1. LP8733xEVM and LP8732xEVM

2 Setup

This section describes the jumpers and connectors on the EVMs as well and how to properly connect, set up, and use the LP8733xEVM and LP8732xEVM.

Many of the components on the LP8733xEVM and LP8732xEVM are susceptible to damage by electrostatic discharge (ESD). Customers are advised to observe proper ESD handling precautions when unpacking and handling the EVM, including the use of a grounded wrist strap at an approved ESD workstation.

On opening the LP8733xEVM or LP8732xEVM package, ensure that these items are included:

- LP8733xEVM or LP8732xEVM evaluation board
- USB cable

If any of the items are missing, contact the closest Texas Instruments Product Information Center to inquire about a replacement.

2.1 Input/Output Connector Description

The description of the main connectors on the EVM board are as follows:

- Connector J5 is the power input terminal for the EVM board. The terminal block provides a power (VIN) and ground (GND) connection to allow the user to attach the EVM to a cable harness.
- Connector J19 is the regulated output voltage of the first buck converter. The terminal block provides a power (+) and ground (–) connection to allow the user to attach the EVM to a cable harness for connecting a load.
- Connector J21 is the regulated output voltage of the second buck converter. The terminal block provides a power (+) and ground (–) connection to allow the user to attach the EVM to a cable harness for connecting a load.
- Connector J20 is the regulated output voltage of the first LDO. The terminal block provides a power (+) and ground (–) connection to allow the user to attach the EVM to a cable harness for connecting a load.
- Connector J22 is the regulated output voltage of the second LDO. The terminal block provides a power (+) and ground (–) connection to allow the user to attach the EVM to a cable harness for connecting a load.
- Use connector J9 to sense V_{OUT} from Buck0 and Buck1.
- Use connector J8 for sensing input voltage to all four regulators: Buck0, Buck1, LDO0, LDO1.
- Connector J28 is for connecting USB cable to EVM board. It is compatible with a Mini USB Type B receptacle.

2.2 Software Installation

The EVM is controlled through a graphical user interface (GUI) software. The software communicates with the EVM through an available USB port. The minimum hardware requirements for the EVM software are:

- IBM PC-compatible computer running a Microsoft Windows® XP or newer operating system
- Available USB port
- Mouse

The latest downloadable software is available at <http://www.ti.com/tool/LP87333Q1EVM>. Download the zip file onto your local hard drive, and then unzip this folder. Connect the EVM to the PC with the USB cable. Refer to [Figure 1](#).

1. With the power supply disconnected from the EVM unit, open the un-zipped folder and click on the LP8733_installer.exe file to start the software.
2. On the evaluation software window bottom left corner, you should see text “Hardware connected”. Refer to [Figure 2](#).

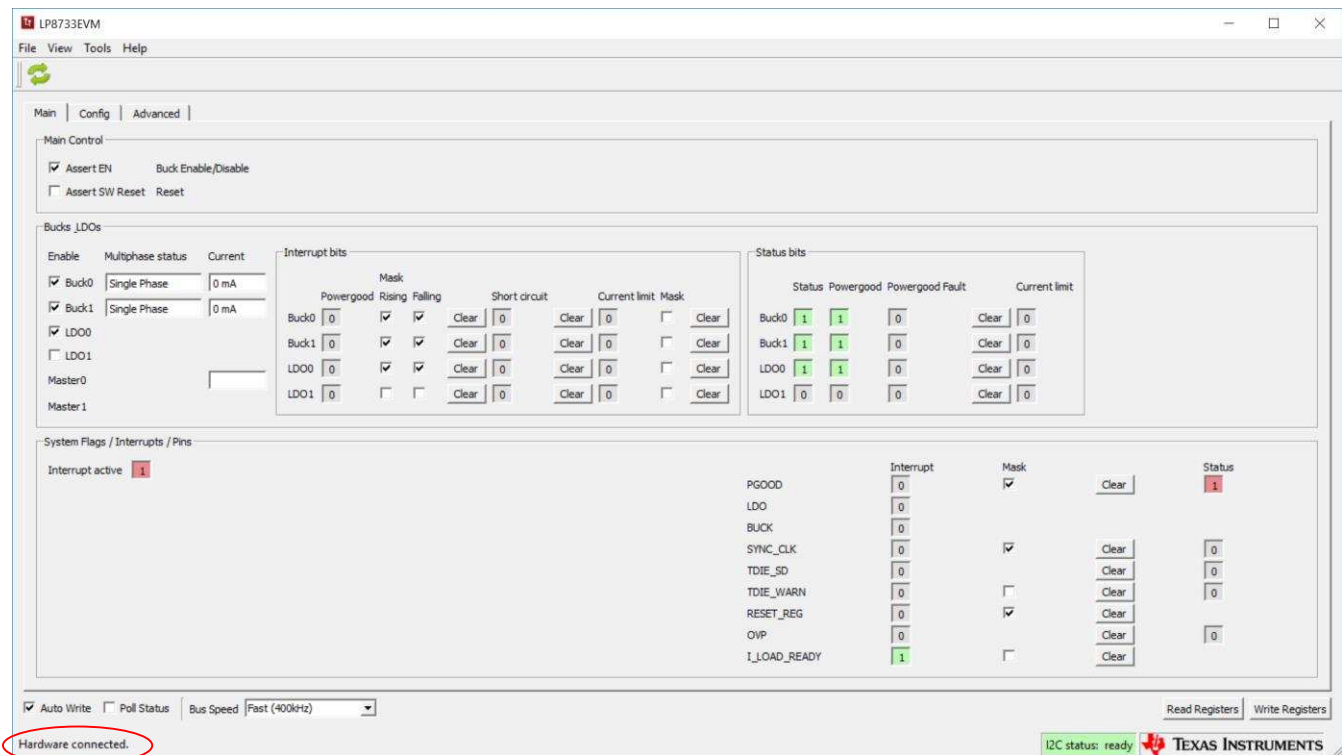

Figure 2. Evaluation Software GUI When EVM is Connected to the PC using USB Cable

2.3 Power Supply Setup

A bench-top DC power supply is needed to power up the EVM. For full-load testing of the LP8733xEVM or LP8732xEVM, a DC-power supply capable of at least 8 A and 4 V is required. 4 A is suggested as a practical minimum for partial load. The power supply is connected to the EVM using connector J5. The power supply and cabling must present low impedance to the UUT; the length of power supply cables must be minimized. Remote sense, using connector J11, can be used to compensate for voltage drops in the cabling.

With the power supply disconnected from the EVM, set the supply to 3.7-V DC and the current limit to 4 A, minimum. Set the power supply output OFF. Connect the positive terminal (+) of the power supply to VIN and negative terminal (–) to GND on the EVM (J5 power-in terminal block). Check that jumpers on the board are set as shown in (factory default jumper configuration).

Set power supply output ON, and then continue with the following steps:

1. Click on Assert EN check box. See marking 1 in [Figure 3](#).
2. Click on Read Registers button (marking 2 in [Figure 3](#)). User should see “I2C Status: ready” message on the green background next to the Read Registers button.

The EVM is now ready for testing with default register settings loaded.

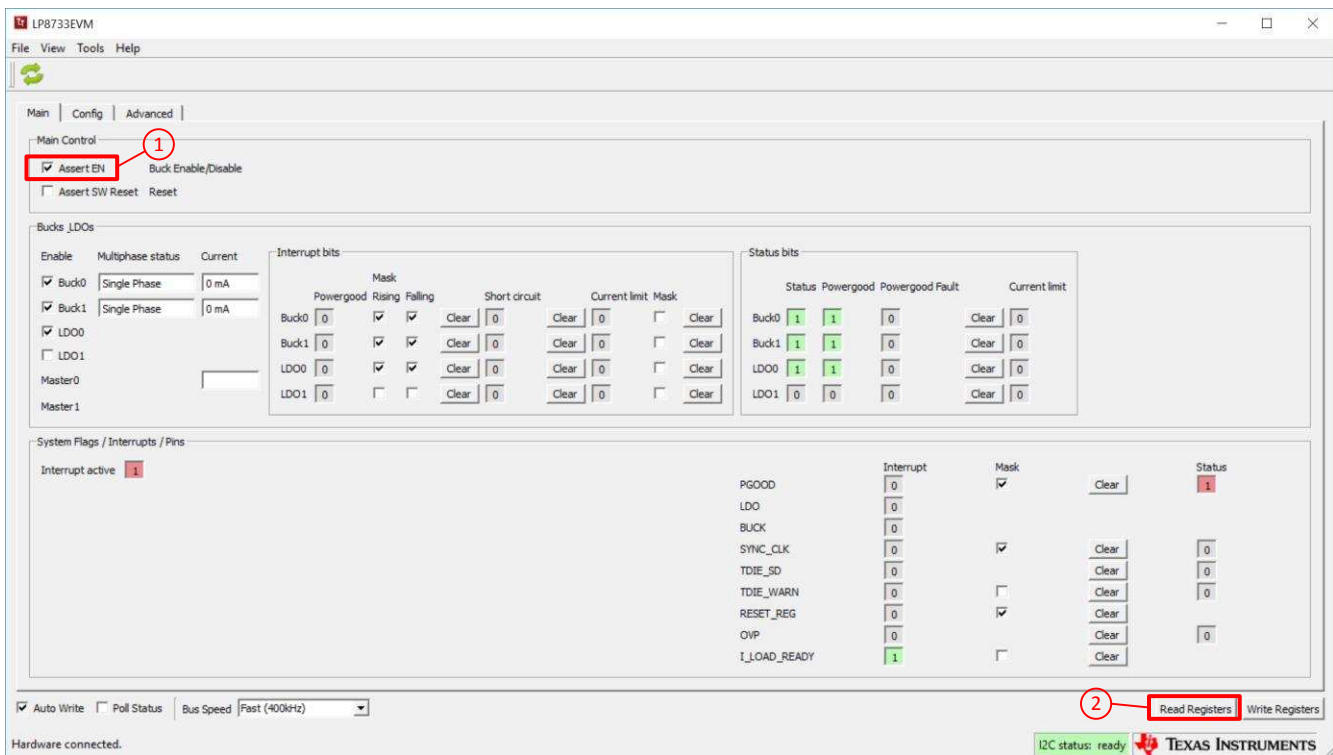

Figure 3. Evaluation Software GUI Showing Steps Needed to Power up the LP8733xEVM and LP8732xEVM

2.4 Notes on Efficiency Measurement Procedure

Output Connections: An appropriate electronic load or high-power system source meter instrument, specified for operation down to 700 mV, is desirable for loading the EVM. The maximum load current is specified as 8 A. Be sure to choose the correct wire size when attaching the electronic load. A wire resistance that is too high causes a voltage drop in the power distribution path, which becomes significant compared to the absolute value of the output voltage. Connect an electric load to J19 or J21. It is advised that, prior to connecting the load, it be set to sink 0 A to avoid power surges or possible shocks.

Voltage drop across the PCB traces yield inaccurate efficiency measurements. For the most accurate voltage measurement at the EVM, use J8 to measure the input voltage and J9 to measure the output voltage.

To measure the current flowing to/from the UUT, use the current meter of the DC power supply/electric load as long as it is accurate. Some power source ammeters may show offset of several milliamps and thus yields inaccurate efficiency measurements. In order to perform very accurate I_Q measurements on the EVM, disconnect input protective Zener diode D1 by removing the shunt J7 from the board. When connected, this diode will cause some leakage, especially at high VIN voltages.

3 GUI Overview

The evaluation software has the following tabs: Main, Config, and Advanced. The three tabs together provide the user access to the whole register map of the LP8732 and LP8733 devices.

3.1 Main Tab

The Main tab has the elemental controls for the EVM and provides a view of the chip status. Starting from top, the main controls are:

- Assert EN: This checkbox asserts logic high level voltage to LP8732 or LP8733 EN pin. Asserting EN may enable the Buck/LDO regulator(s) depending on the register settings.
- Assert SW Reset: To perform a complete SW reset to the chip, click this checkbox. See the LP8732x and LP8733x data sheets for explanation of various reset scenarios.

The "Bucks LDOs" section provides enable controls and status information for bucks and LDOs as follows:

- Enable check boxes provide enable/disable control for all bucks and LDOs.
- The "Current" field provides approximate level of load current on each buck.

The "System Flags / Interrupts / Pins" section as well as the "Interrupt bits" and the "Status bits" sections give data on system faults and warnings. If the interrupt is set for any reason the Interrupt field shall show '1' on red background. The flag causing the interrupt will also be set on the Main tab. Interrupts on LP8732 or LP8733 can only be cleared by writing '1' to associated registers. Any individual flag can be cleared by clicking the "Clear" button next to each flag. Some of the flags also have a mask bit. If "Mask" check-box of certain flag is checked, the interrupt is not generated. The "Status" bits will show the current status of the faults.

At the bottom of the GUI window is the "Auto Write" checkbox. If "Auto Write" is checked (default) any checking, un-checking or pull-down menu selections will immediately launch I2C writes to the chip register(s). If not checked, the user can update the chip registers to correspond the configuration selected on the GUI by clicking "Write Registers".

If "Poll Status" is selected the software sends a query to the LP8732 or LP8733 device at a fixed interval in order to detect the status of the chip, including operation mode and load current. If not selected, user can read the registers by clicking "Read Registers".

3.2 Other Tabs and Menus

The "Tools" pulldown menu hosts another way of accessing the LP8732 or LP8733 registers. The "Direct Register Access" tool can be used to read or write any register. When using direct register access, un-checking the "Poll Status" check-box is recommended. This way the GUI only does the reads and writes commanded from the direct access dialog.

The "Config" and "Advanced" tabs provide the user with pulldown menus and check-boxes for the part of the register space that is not covered by the Main tab, such as output voltage control. These controls are self-explanatory. Please refer to the LP8733/32 datasheet for explanation of the functions.

3.3 Console

To show or hide the console, toggle the option in the View pulldown menu. The console can be used to access any of the LP8732 or LP8733 registers. Registers can be read or written simply by referring to the logical registers by their name.

The console supports use of scripts. If a text file containing commands supported by the console is stored in the same folder as the evaluation software executable, then the script can be launched from the console by typing the text file name, like script.txt.

4 Board Layout

This section describes the board layout of the LP8733xEVM and LP8732xEVM. See LP8732xx or LP8733xx data sheet for specific PCB layout recommendations. The board is constructed on a 4-layer PCB. [Figure 4](#) shows the top view of the entire board. Routing is mostly done on top and bottom layers. Top layer contains the copper areas connecting the VOUT pads of the inductors and output capacitors together and to the load terminals. 2nd layer is the ground plane and 3rd layer contains the VIN copper area and copper areas for the VOUT nets. Also the bottom layer contains large copper area filled with ground. Input capacitors are placed as close as possible to the LP8732xx or LP8733xx device for keeping the critical VIN and GND traces short. Output capacitors and inductors are placed around the input capacitors.

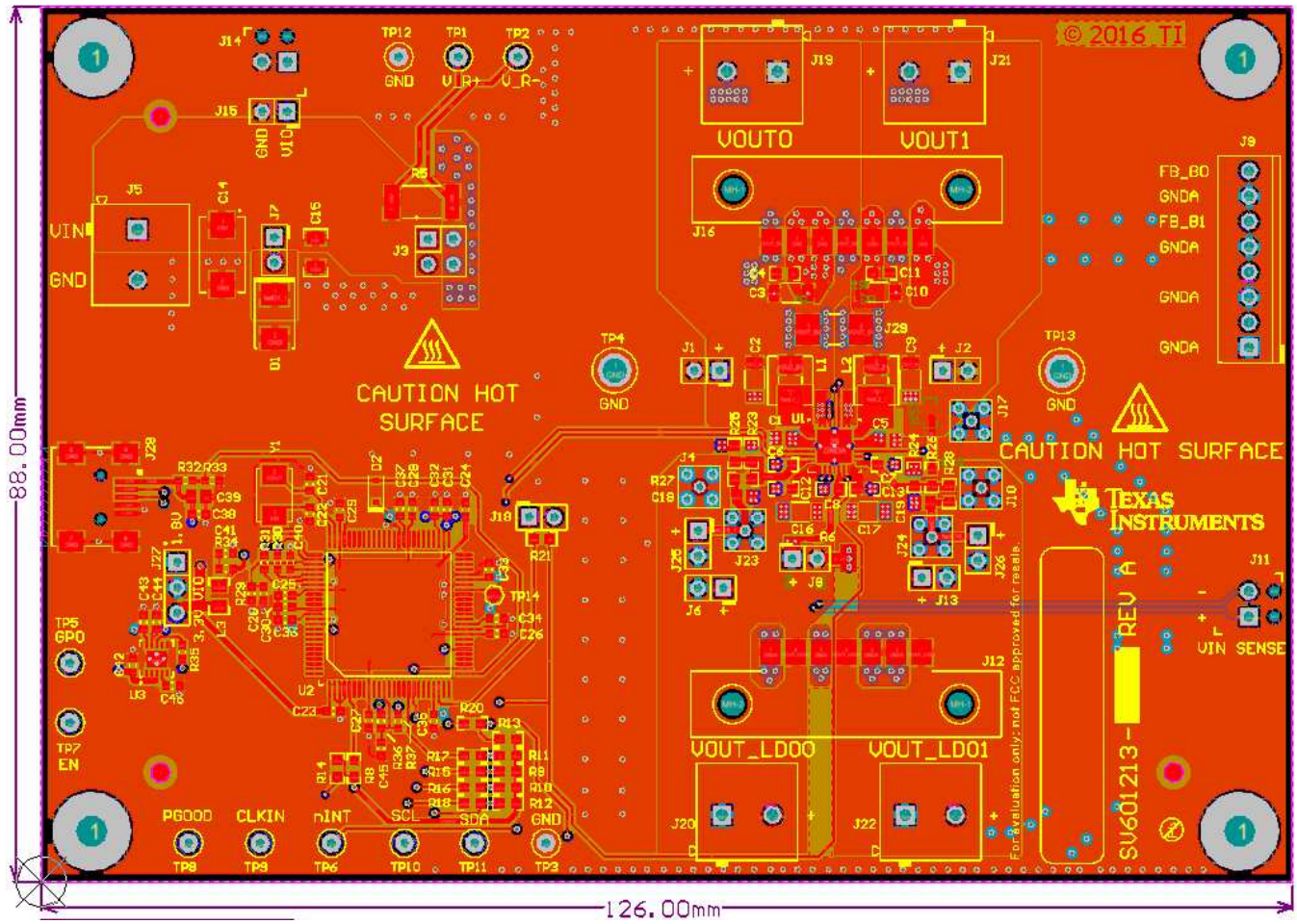
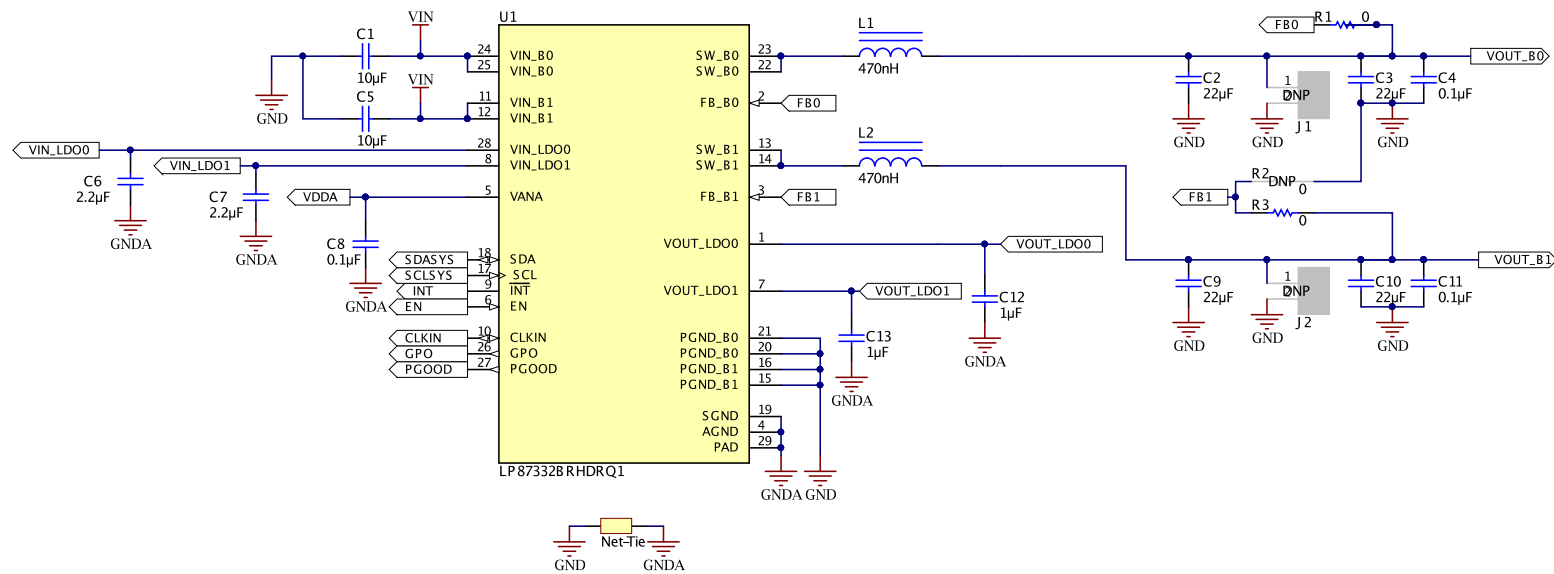

Figure 4. LP8733xEVM and LP8732xEVM Board Layout

5 Evaluation Board Schematic



Copyright © 2017, Texas Instruments Incorporated

Figure 5. EVM Schematic

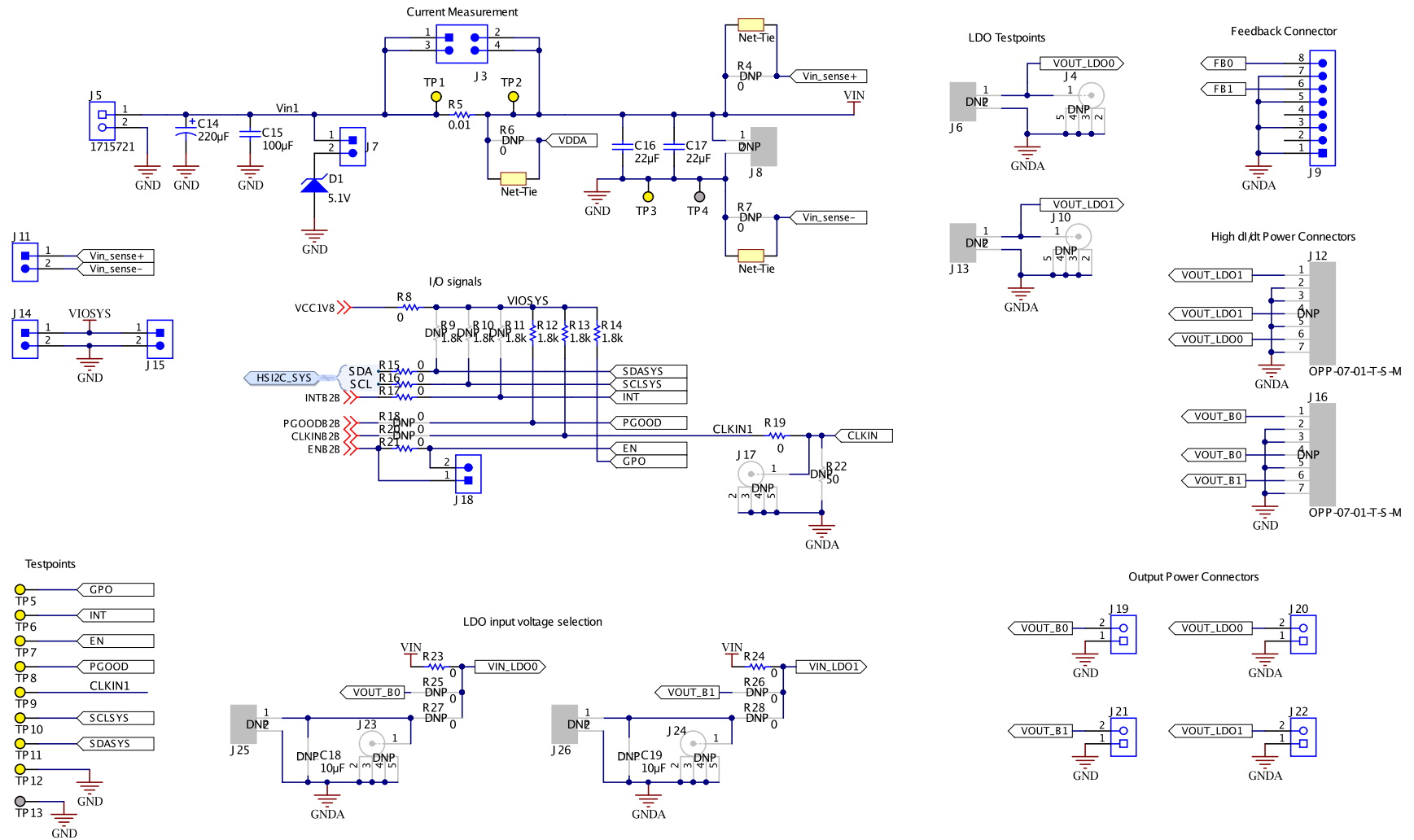

Copyright © 2017, Texas Instruments Incorporated

Figure 6. EVM Connectors

6 Bill of Materials

QTY	DESIGNATOR	DESCRIPTION	PART NUMBER	MANUFACTURER
1	!PCB1	Printed Circuit Board	SV601213	Any
2	C1, C5	CAP, CERM, 10 μ F, 10 V, +/- 10%, X7R, 0805	GCM21BR71A106KE22L	MuRata
6	C2, C3, C9, C10, C16, C17	CAP, CERM, 22 μ F, 10 V, +/- 10%, X7R, AEC-Q200 Grade 1, 1206	GCM31CR71A226KE02	MuRata
3	C4, C8, C11	CAP, CERM, 0.1 μ F, 16 V, +/- 10%, X7R, 0603	GRM188R71C104KA01D	MuRata
2	C6, C7	CAP, CERM, 2.2 μ F, 6.3 V, +/- 10%, X7R, AEC-Q200 Grade 1, 0603	GCM188R70J225KE22D	MuRata
2	C12, C13	CAP, CERM, 1 μ F, 16 V, +/- 10%, X7R, AEC-Q200 Grade 1, 0603	GCM188R71C105KA64D	MuRata
1	C14	CAP, TA, 220 μ F, 10 V, +/- 10%, 0.05 ohm, SMD	TPSD227K010R0050	AVX
1	C15	CAP, CERM, 100 μ F, 6.3 V, +/- 20%, X5R, 1206	GRM31CR60J107ME39L	MuRata
2	C20, C38	CAP, CERM, 10 pF, 50 V, +/- 5%, C0G/NP0, 0603	GRM1885C1H100JA01D	MuRata
2	C21, C22	CAP, CERM, 15 pF, 100 V, +/- 5%, C0G/NP0, 0603	GRM1885C2A150JA01D	MuRata
13	C23, C25, C26, C27, C28, C29, C30, C32, C34, C35, C36, C37, C40	CAP, CERM, 0.1 μ F, 25 V, +/- 10%, X7R, 0603	GRM188R71E104KA01D	MuRata
4	C24, C31, C33, C41	CAP, CERM, 10 μ F, 16 V, +/- 20%, X5R, 0603	EMK107BBJ106MA-T	Taiyo Yuden
1	C39	CAP, CERM, 10 μ F, 16 V, +/- 10%, X5R, 0805	EMK212BJ106KG-T	Taiyo Yuden
4	C42, C43, C44, C45	CAP, CERM, 1 μ F, 25 V, +/- 10%, X5R, 0603	GRM188R61E105KA12D	MuRata
1	C46	CAP, CERM, 0.01 μ F, 50 V, +/- 10%, X5R, 0603	GRM188R61H103KA01D	MuRata
1	D1	Diode, Zener, 5.1 V, 5 W, SMB	SMBJ5338B-TP	Micro Commercial Components
1	D2	Diode, Schottky, 30 V, 0.2 A, SOD-323	BAT42WS-7-F	Diodes Inc.
4	H1, H2, H3, H4	Machine Screw, Round, #4-40 x 1/4, Nylon, Philips panhead	NY PMS 440 0025 PH	B&F Fastener Supply
4	H5, H6, H7, H8	Standoff, Hex, 0.5"L #4-40 Nylon	1902C	Keystone
1	J3	Header, 100mil, 2x2, Gold, TH	TSW-102-07-G-D	Samtec
5	J5, J19, J20, J21, J22	Terminal Block, 5.08 mm, 2x1, TH	1715721	Phoenix Contact
3	J7, J15, J18	Header, 100mil, 2x1, Gold, TH	TSW-102-07-G-S	Samtec
1	J9	Terminal Block, 8x1, 2.54 mm, TH	1725711	Phoenix Contact
2	J11, J14	Terminal Block, 100mil, 2x1, 6A, 63V, TH	1725656	Phoenix Contact
1	J27	Header, 100mil, 3x1, Gold, TH	HTSW-103-07-G-S	Samtec
1	J28	Connector, Receptacle, Mini-USB Type B, R/A, Top Mount SMT	1734035-2	TE Connectivity
2	L1, L2	Inductor, Shielded, 470 nH, 4.7 A, 0.021 ohm, SMD	DFE252012PD-R47M	MuRata Toko
1	L3	Inductor, Wirewound, Ferrite, 10 μ H, 0.12 A, 0.5 ohm, SMD	LB2012T100KR	Taiyo Yuden
1	LBL1	Thermal Transfer Printable Labels, 1.250" W x 0.250" H - 10,000 per roll	THT-13-457-10	Brady
3	R1, R3, R19	RES, 0, 5%, 0.063 W, 0402	CRCW04020000Z0ED	Vishay-Dale
1	R5	RES, 0.01, 1%, 3 W, 2512	CRA2512-FZ-R010ELF	Bourns
5	R8, R15, R16, R17, R21	RES, 0, 5%, 0.1 W, 0603	CRCW06030000Z0EA	Vishay-Dale
3	R12, R13, R14	RES, 1.8 k, 5%, 0.1 W, 0603	CRCW06031K80JNEA	Vishay-Dale

2	R23, R24	RES, 0, 5%, 0.1 W, 0603	MCR03EZPJ000	Rohm
1	R29	RES, 6.80 k, 1%, 0.1 W, 0603	RC0603FR-076K8L	Yageo America
2	R30, R31	RES, 39.0, 1%, 0.1 W, 0603	RC0603FR-0739RL	Yageo America
1	R32	RES, 68.0 k, 1%, 0.1 W, 0603	RC0603FR-0768KL	Yageo America
1	R33	RES, 33.0 k, 1%, 0.1 W, 0603	RC0603FR-0733KL	Yageo America
1	R34	RES, 1.00, 1%, 0.1 W, 0603	RC0603FR-071RL	Yageo America
1	R35	RES, 470 k, 5%, 0.1 W, 0603	CRCW0603470KJNEA	Vishay-Dale
2	R36, R37	RES, 1.00 k, 1%, 0.1 W, 0603	CRCW06031K00FKEA	Vishay-Dale
4	SH-J1, SH-J2, SH-J3, SH-J4	Shunt, 100mil, Gold plated, Black	969102-0000-DA	3M
11	TP1, TP2, TP3, TP5, TP6, TP7, TP8, TP9, TP10, TP11, TP12	Test Point, Miniature, Yellow, TH	5004	Keystone
2	TP4, TP13	Terminal, Turret, TH, Double	1502-2	Keystone
1	U1	Dual High-Current Buck Converter and Dual Linear Regulator, RHD0028W (VQFN-28)	see Table 1	Texas Instruments
1	U2	AT91SAM ARM-based Flash MCU, LQFP100	ATSAM3U2CA-AU	Atmel
1	U3	Dual Linear Regulator with 300mA and 150mA Outputs and Power-On-Reset, 10-pin LLP, Pb-Free	LP3996SD-1833/NOPB	Texas Instruments
1	Y1	Crystal, 12MHz, 12pF, SMD	CX5032GB12000H0PESZZ	AVX
0	C18, C19	CAP, CERM, 10 µF, 10 V, +/- 10%, X7R, 0805	GCM21BR71A106KE22L	MuRata
0	FID1, FID2, FID3	Fiducial mark. There is nothing to buy or mount.	N/A	N/A
0	J1, J2, J6, J8, J13, J25, J26	Header, 100mil, 2x1, Gold, TH	TSW-102-07-G-S	Samtec
0	J4, J10, J17, J23, J24	Connector, MMCX, Vertical RCP 6GHz, 50Ohm, TH	135-9701-201	Emerson Network Power
0	J12, J16	Connector, 7 pos, 2.54mm, R/A, SMT	OPP-07-01-T-S-M	Samtec
0	J29	JUMPER TIN SMD	S1911-46R	Harwin
0	R2, R18, R20	RES, 0, 5%, 0.1 W, 0603	CRCW06030000Z0EA	Vishay-Dale
0	R4, R6, R7	RES, 0, 5%, 0.063 W, 0402	CRCW04020000Z0ED	Vishay-Dale
0	R9, R10, R11	RES, 1.8 k, 5%, 0.1 W, 0603	CRCW06031K80JNEA	Vishay-Dale
0	R22	RES, 50, 1%, 0.1 W, 0603	CRCW060350R0FKEA	Vishay-Dale
0	R25, R26, R27, R28	RES, 0, 5%, 0.1 W, 0603	MCR03EZPJ000	Rohm

Table 1. U1 Population Options

EVM Orderable Number	U1 Orderable Part Number
LP87321Q1EVM	LP87322ERHDRQ1
LP87322Q1EVM	LP873220RHDRQ1
LP87323Q1EVM	LP873222RHDRQ1
LP87331Q1EVM	LP87332ARHDRQ1
LP87332Q1EVM	LP87332DRHDRQ1
LP87333Q1EVM	LP87332BRHDRQ1

Revision History

NOTE: Page numbers for previous revisions may differ from page numbers in the current version.

Changes from Original (February 2017) to A Revision	Page
• Changed device number references "LP8733xEVM and LP8732xEVM" and data sheet references to LP8732xx or LP8733xx to reflect correct device nomenclature	1
• Added Table 1 for detail of orderable numbers	13

STANDARD TERMS FOR EVALUATION MODULES

1. *Delivery:* TI delivers TI evaluation boards, kits, or modules, including any accompanying demonstration software, components, and/or documentation which may be provided together or separately (collectively, an "EVM" or "EVMs") to the User ("User") in accordance with the terms set forth herein. User's acceptance of the EVM is expressly subject to the following terms.
 - 1.1 EVMs are intended solely for product or software developers for use in a research and development setting to facilitate feasibility evaluation, experimentation, or scientific analysis of TI semiconductor products. EVMs have no direct function and are not finished products. EVMs shall not be directly or indirectly assembled as a part or subassembly in any finished product. For clarification, any software or software tools provided with the EVM ("Software") shall not be subject to the terms and conditions set forth herein but rather shall be subject to the applicable terms that accompany such Software
 - 1.2 EVMs are not intended for consumer or household use. EVMs may not be sold, sublicensed, leased, rented, loaned, assigned, or otherwise distributed for commercial purposes by Users, in whole or in part, or used in any finished product or production system.
2. *Limited Warranty and Related Remedies/Disclaimers:*
 - 2.1 These terms do not apply to Software. The warranty, if any, for Software is covered in the applicable Software License Agreement.
 - 2.2 TI warrants that the TI EVM will conform to TI's published specifications for ninety (90) days after the date TI delivers such EVM to User. Notwithstanding the foregoing, TI shall not be liable for a nonconforming EVM if (a) the nonconformity was caused by neglect, misuse or mistreatment by an entity other than TI, including improper installation or testing, or for any EVMs that have been altered or modified in any way by an entity other than TI, (b) the nonconformity resulted from User's design, specifications or instructions for such EVMs or improper system design, or (c) User has not paid on time. Testing and other quality control techniques are used to the extent TI deems necessary. TI does not test all parameters of each EVM. User's claims against TI under this Section 2 are void if User fails to notify TI of any apparent defects in the EVMs within ten (10) business days after delivery, or of any hidden defects with ten (10) business days after the defect has been detected.
 - 2.3 TI's sole liability shall be at its option to repair or replace EVMs that fail to conform to the warranty set forth above, or credit User's account for such EVM. TI's liability under this warranty shall be limited to EVMs that are returned during the warranty period to the address designated by TI and that are determined by TI not to conform to such warranty. If TI elects to repair or replace such EVM, TI shall have a reasonable time to repair such EVM or provide replacements. Repaired EVMs shall be warranted for the remainder of the original warranty period. Replaced EVMs shall be warranted for a new full ninety (90) day warranty period.
3. *Regulatory Notices:*
 - 3.1 *United States*
 - 3.1.1 *Notice applicable to EVMs not FCC-Approved:*

FCC NOTICE: This kit is designed to allow product developers to evaluate electronic components, circuitry, or software associated with the kit to determine whether to incorporate such items in a finished product and software developers to write software applications for use with the end product. This kit is not a finished product and when assembled may not be resold or otherwise marketed unless all required FCC equipment authorizations are first obtained. Operation is subject to the condition that this product not cause harmful interference to licensed radio stations and that this product accept harmful interference. Unless the assembled kit is designed to operate under part 15, part 18 or part 95 of this chapter, the operator of the kit must operate under the authority of an FCC license holder or must secure an experimental authorization under part 5 of this chapter.
 - 3.1.2 *For EVMs annotated as FCC – FEDERAL COMMUNICATIONS COMMISSION Part 15 Compliant:*

CAUTION

This device complies with part 15 of the FCC Rules. Operation is subject to the following two conditions: (1) This device may not cause harmful interference, and (2) this device must accept any interference received, including interference that may cause undesired operation.

Changes or modifications not expressly approved by the party responsible for compliance could void the user's authority to operate the equipment.

FCC Interference Statement for Class A EVM devices

NOTE: This equipment has been tested and found to comply with the limits for a Class A digital device, pursuant to part 15 of the FCC Rules. These limits are designed to provide reasonable protection against harmful interference when the equipment is operated in a commercial environment. This equipment generates, uses, and can radiate radio frequency energy and, if not installed and used in accordance with the instruction manual, may cause harmful interference to radio communications. Operation of this equipment in a residential area is likely to cause harmful interference in which case the user will be required to correct the interference at his own expense.

FCC Interference Statement for Class B EVM devices

NOTE: This equipment has been tested and found to comply with the limits for a Class B digital device, pursuant to part 15 of the FCC Rules. These limits are designed to provide reasonable protection against harmful interference in a residential installation. This equipment generates, uses and can radiate radio frequency energy and, if not installed and used in accordance with the instructions, may cause harmful interference to radio communications. However, there is no guarantee that interference will not occur in a particular installation. If this equipment does cause harmful interference to radio or television reception, which can be determined by turning the equipment off and on, the user is encouraged to try to correct the interference by one or more of the following measures:

- Reorient or relocate the receiving antenna.
- Increase the separation between the equipment and receiver.
- Connect the equipment into an outlet on a circuit different from that to which the receiver is connected.
- Consult the dealer or an experienced radio/TV technician for help.

3.2 Canada

3.2.1 For EVMs issued with an Industry Canada Certificate of Conformance to RSS-210 or RSS-247

Concerning EVMs Including Radio Transmitters:

This device complies with Industry Canada license-exempt RSSs. Operation is subject to the following two conditions:

(1) this device may not cause interference, and (2) this device must accept any interference, including interference that may cause undesired operation of the device.

Concernant les EVMs avec appareils radio:

Le présent appareil est conforme aux CNR d'Industrie Canada applicables aux appareils radio exempts de licence. L'exploitation est autorisée aux deux conditions suivantes: (1) l'appareil ne doit pas produire de brouillage, et (2) l'utilisateur de l'appareil doit accepter tout brouillage radioélectrique subi, même si le brouillage est susceptible d'en compromettre le fonctionnement.

Concerning EVMs Including Detachable Antennas:

Under Industry Canada regulations, this radio transmitter may only operate using an antenna of a type and maximum (or lesser) gain approved for the transmitter by Industry Canada. To reduce potential radio interference to other users, the antenna type and its gain should be so chosen that the equivalent isotropically radiated power (e.i.r.p.) is not more than that necessary for successful communication. This radio transmitter has been approved by Industry Canada to operate with the antenna types listed in the user guide with the maximum permissible gain and required antenna impedance for each antenna type indicated. Antenna types not included in this list, having a gain greater than the maximum gain indicated for that type, are strictly prohibited for use with this device.

Concernant les EVMs avec antennes détachables

Conformément à la réglementation d'Industrie Canada, le présent émetteur radio peut fonctionner avec une antenne d'un type et d'un gain maximal (ou inférieur) approuvé pour l'émetteur par Industrie Canada. Dans le but de réduire les risques de brouillage radioélectrique à l'intention des autres utilisateurs, il faut choisir le type d'antenne et son gain de sorte que la puissance isotrope rayonnée équivalente (p.i.r.e.) ne dépasse pas l'intensité nécessaire à l'établissement d'une communication satisfaisante. Le présent émetteur radio a été approuvé par Industrie Canada pour fonctionner avec les types d'antenne énumérés dans le manuel d'usage et ayant un gain admissible maximal et l'impédance requise pour chaque type d'antenne. Les types d'antenne non inclus dans cette liste, ou dont le gain est supérieur au gain maximal indiqué, sont strictement interdits pour l'exploitation de l'émetteur.

3.3 Japan

3.3.1 *Notice for EVMs delivered in Japan:* Please see http://www.tij.co.jp/lstds/ti_ja/general/eStore/notice_01.page 日本国内に輸入される評価用キット、ボードについては、次のところをご覧ください。
http://www.tij.co.jp/lstds/ti_ja/general/eStore/notice_01.page

3.3.2 *Notice for Users of EVMs Considered "Radio Frequency Products" in Japan:* EVMs entering Japan may not be certified by TI as conforming to Technical Regulations of Radio Law of Japan.

If User uses EVMs in Japan, not certified to Technical Regulations of Radio Law of Japan, User is required to follow the instructions set forth by Radio Law of Japan, which includes, but is not limited to, the instructions below with respect to EVMs (which for the avoidance of doubt are stated strictly for convenience and should be verified by User):

1. Use EVMs in a shielded room or any other test facility as defined in the notification #173 issued by Ministry of Internal Affairs and Communications on March 28, 2006, based on Sub-section 1.1 of Article 6 of the Ministry's Rule for Enforcement of Radio Law of Japan,
2. Use EVMs only after User obtains the license of Test Radio Station as provided in Radio Law of Japan with respect to EVMs, or
3. Use of EVMs only after User obtains the Technical Regulations Conformity Certification as provided in Radio Law of Japan with respect to EVMs. Also, do not transfer EVMs, unless User gives the same notice above to the transferee. Please note that if User does not follow the instructions above, User will be subject to penalties of Radio Law of Japan.

【無線電波を送信する製品の開発キットをお使いになる際の注意事項】 開発キットの中には技術基準適合証明を受けていないものがあります。技術適合証明を受けていないものご使用に際しては、電波法遵守のため、以下のいずれかの措置を取っていただく必要がありますのでご注意ください。

1. 電波法施行規則第6条第1項第1号に基づく平成18年3月28日総務省告示第173号で定められた電波暗室等の試験設備でご使用いただく。
2. 実験局の免許を取得後ご使用いただく。
3. 技術基準適合証明を取得後ご使用いただく。

なお、本製品は、上記の「ご使用にあたっての注意」を譲渡先、移転先に通知しない限り、譲渡、移転できないものとします。

上記を遵守頂けない場合は、電波法の罰則が適用される可能性があることをご留意ください。日本テキサス・インスツルメンツ株式会社
東京都新宿区西新宿 6 丁目 2 4 番 1 号
西新宿三井ビル

3.3.3 *Notice for EVMs for Power Line Communication:* Please see http://www.tij.co.jp/llds/ti_ja/general/eStore/notice_02.page
電力線搬送波通信についての開発キットをお使いになる際の注意事項については、次のところをご覧ください。 http://www.tij.co.jp/llds/ti_ja/general/eStore/notice_02.page

3.4 *European Union*

3.4.1 *For EVMs subject to EU Directive 2014/30/EU (Electromagnetic Compatibility Directive):*

This is a class A product intended for use in environments other than domestic environments that are connected to a low-voltage power-supply network that supplies buildings used for domestic purposes. In a domestic environment this product may cause radio interference in which case the user may be required to take adequate measures.

4 *EVM Use Restrictions and Warnings:*

4.1 EVMS ARE NOT FOR USE IN FUNCTIONAL SAFETY AND/OR SAFETY CRITICAL EVALUATIONS, INCLUDING BUT NOT LIMITED TO EVALUATIONS OF LIFE SUPPORT APPLICATIONS.

4.2 User must read and apply the user guide and other available documentation provided by TI regarding the EVM prior to handling or using the EVM, including without limitation any warning or restriction notices. The notices contain important safety information related to, for example, temperatures and voltages.

4.3 *Safety-Related Warnings and Restrictions:*

4.3.1 User shall operate the EVM within TI's recommended specifications and environmental considerations stated in the user guide, other available documentation provided by TI, and any other applicable requirements and employ reasonable and customary safeguards. Exceeding the specified performance ratings and specifications (including but not limited to input and output voltage, current, power, and environmental ranges) for the EVM may cause personal injury or death, or property damage. If there are questions concerning performance ratings and specifications, User should contact a TI field representative prior to connecting interface electronics including input power and intended loads. Any loads applied outside of the specified output range may also result in unintended and/or inaccurate operation and/or possible permanent damage to the EVM and/or interface electronics. Please consult the EVM user guide prior to connecting any load to the EVM output. If there is uncertainty as to the load specification, please contact a TI field representative. During normal operation, even with the inputs and outputs kept within the specified allowable ranges, some circuit components may have elevated case temperatures. These components include but are not limited to linear regulators, switching transistors, pass transistors, current sense resistors, and heat sinks, which can be identified using the information in the associated documentation. When working with the EVM, please be aware that the EVM may become very warm.

4.3.2 EVMs are intended solely for use by technically qualified, professional electronics experts who are familiar with the dangers and application risks associated with handling electrical mechanical components, systems, and subsystems. User assumes all responsibility and liability for proper and safe handling and use of the EVM by User or its employees, affiliates, contractors or designees. User assumes all responsibility and liability to ensure that any interfaces (electronic and/or mechanical) between the EVM and any human body are designed with suitable isolation and means to safely limit accessible leakage currents to minimize the risk of electrical shock hazard. User assumes all responsibility and liability for any improper or unsafe handling or use of the EVM by User or its employees, affiliates, contractors or designees.

4.4 User assumes all responsibility and liability to determine whether the EVM is subject to any applicable international, federal, state, or local laws and regulations related to User's handling and use of the EVM and, if applicable, User assumes all responsibility and liability for compliance in all respects with such laws and regulations. User assumes all responsibility and liability for proper disposal and recycling of the EVM consistent with all applicable international, federal, state, and local requirements.

5. *Accuracy of Information:* To the extent TI provides information on the availability and function of EVMs, TI attempts to be as accurate as possible. However, TI does not warrant the accuracy of EVM descriptions, EVM availability or other information on its websites as accurate, complete, reliable, current, or error-free.

6. *Disclaimers:*

6.1 EXCEPT AS SET FORTH ABOVE, EVMS AND ANY MATERIALS PROVIDED WITH THE EVM (INCLUDING, BUT NOT LIMITED TO, REFERENCE DESIGNS AND THE DESIGN OF THE EVM ITSELF) ARE PROVIDED "AS IS" AND "WITH ALL FAULTS." TI DISCLAIMS ALL OTHER WARRANTIES, EXPRESS OR IMPLIED, REGARDING SUCH ITEMS, INCLUDING BUT NOT LIMITED TO ANY EPIDEMIC FAILURE WARRANTY OR IMPLIED WARRANTIES OF MERCHANTABILITY OR FITNESS FOR A PARTICULAR PURPOSE OR NON-INFRINGEMENT OF ANY THIRD PARTY PATENTS, COPYRIGHTS, TRADE SECRETS OR OTHER INTELLECTUAL PROPERTY RIGHTS.

6.2 EXCEPT FOR THE LIMITED RIGHT TO USE THE EVM SET FORTH HEREIN, NOTHING IN THESE TERMS SHALL BE CONSTRUED AS GRANTING OR CONFERRING ANY RIGHTS BY LICENSE, PATENT, OR ANY OTHER INDUSTRIAL OR INTELLECTUAL PROPERTY RIGHT OF TI, ITS SUPPLIERS/LICENSORS OR ANY OTHER THIRD PARTY, TO USE THE EVM IN ANY FINISHED END-USER OR READY-TO-USE FINAL PRODUCT, OR FOR ANY INVENTION, DISCOVERY OR IMPROVEMENT, REGARDLESS OF WHEN MADE, CONCEIVED OR ACQUIRED.

7. *USER'S INDEMNITY OBLIGATIONS AND REPRESENTATIONS.* USER WILL DEFEND, INDEMNIFY AND HOLD TI, ITS LICENSORS AND THEIR REPRESENTATIVES HARMLESS FROM AND AGAINST ANY AND ALL CLAIMS, DAMAGES, LOSSES, EXPENSES, COSTS AND LIABILITIES (COLLECTIVELY, "CLAIMS") ARISING OUT OF OR IN CONNECTION WITH ANY HANDLING OR USE OF THE EVM THAT IS NOT IN ACCORDANCE WITH THESE TERMS. THIS OBLIGATION SHALL APPLY WHETHER CLAIMS ARISE UNDER STATUTE, REGULATION, OR THE LAW OF TORT, CONTRACT OR ANY OTHER LEGAL THEORY, AND EVEN IF THE EVM FAILS TO PERFORM AS DESCRIBED OR EXPECTED.

8. *Limitations on Damages and Liability:*

8.1 *General Limitations.* IN NO EVENT SHALL TI BE LIABLE FOR ANY SPECIAL, COLLATERAL, INDIRECT, PUNITIVE, INCIDENTAL, CONSEQUENTIAL, OR EXEMPLARY DAMAGES IN CONNECTION WITH OR ARISING OUT OF THESE TERMS OR THE USE OF THE EVMS, REGARDLESS OF WHETHER TI HAS BEEN ADVISED OF THE POSSIBILITY OF SUCH DAMAGES. EXCLUDED DAMAGES INCLUDE, BUT ARE NOT LIMITED TO, COST OF REMOVAL OR REINSTALLATION, ANCILLARY COSTS TO THE PROCUREMENT OF SUBSTITUTE GOODS OR SERVICES, RETESTING, OUTSIDE COMPUTER TIME, LABOR COSTS, LOSS OF GOODWILL, LOSS OF PROFITS, LOSS OF SAVINGS, LOSS OF USE, LOSS OF DATA, OR BUSINESS INTERRUPTION. NO CLAIM, SUIT OR ACTION SHALL BE BROUGHT AGAINST TI MORE THAN TWELVE (12) MONTHS AFTER THE EVENT THAT GAVE RISE TO THE CAUSE OF ACTION HAS OCCURRED.

8.2 *Specific Limitations.* IN NO EVENT SHALL TI'S AGGREGATE LIABILITY FROM ANY USE OF AN EVM PROVIDED HEREUNDER, INCLUDING FROM ANY WARRANTY, INDEMNITY OR OTHER OBLIGATION ARISING OUT OF OR IN CONNECTION WITH THESE TERMS, EXCEED THE TOTAL AMOUNT PAID TO TI BY USER FOR THE PARTICULAR EVM(S) AT ISSUE DURING THE PRIOR TWELVE (12) MONTHS WITH RESPECT TO WHICH LOSSES OR DAMAGES ARE CLAIMED. THE EXISTENCE OF MORE THAN ONE CLAIM SHALL NOT ENLARGE OR EXTEND THIS LIMIT.

9. *Return Policy.* Except as otherwise provided, TI does not offer any refunds, returns, or exchanges. Furthermore, no return of EVM(s) will be accepted if the package has been opened and no return of the EVM(s) will be accepted if they are damaged or otherwise not in a resalable condition. If User feels it has been incorrectly charged for the EVM(s) it ordered or that delivery violates the applicable order, User should contact TI. All refunds will be made in full within thirty (30) working days from the return of the components(s), excluding any postage or packaging costs.

10. *Governing Law:* These terms and conditions shall be governed by and interpreted in accordance with the laws of the State of Texas, without reference to conflict-of-laws principles. User agrees that non-exclusive jurisdiction for any dispute arising out of or relating to these terms and conditions lies within courts located in the State of Texas and consents to venue in Dallas County, Texas. Notwithstanding the foregoing, any judgment may be enforced in any United States or foreign court, and TI may seek injunctive relief in any United States or foreign court.

IMPORTANT NOTICE FOR TI DESIGN INFORMATION AND RESOURCES

Texas Instruments Incorporated ("TI") technical, application or other design advice, services or information, including, but not limited to, reference designs and materials relating to evaluation modules, (collectively, "TI Resources") are intended to assist designers who are developing applications that incorporate TI products; by downloading, accessing or using any particular TI Resource in any way, you (individually or, if you are acting on behalf of a company, your company) agree to use it solely for this purpose and subject to the terms of this Notice.

TI's provision of TI Resources does not expand or otherwise alter TI's applicable published warranties or warranty disclaimers for TI products, and no additional obligations or liabilities arise from TI providing such TI Resources. TI reserves the right to make corrections, enhancements, improvements and other changes to its TI Resources.

You understand and agree that you remain responsible for using your independent analysis, evaluation and judgment in designing your applications and that you have full and exclusive responsibility to assure the safety of your applications and compliance of your applications (and of all TI products used in or for your applications) with all applicable regulations, laws and other applicable requirements. You represent that, with respect to your applications, you have all the necessary expertise to create and implement safeguards that (1) anticipate dangerous consequences of failures, (2) monitor failures and their consequences, and (3) lessen the likelihood of failures that might cause harm and take appropriate actions. You agree that prior to using or distributing any applications that include TI products, you will thoroughly test such applications and the functionality of such TI products as used in such applications. TI has not conducted any testing other than that specifically described in the published documentation for a particular TI Resource.

You are authorized to use, copy and modify any individual TI Resource only in connection with the development of applications that include the TI product(s) identified in such TI Resource. NO OTHER LICENSE, EXPRESS OR IMPLIED, BY ESTOPPEL OR OTHERWISE TO ANY OTHER TI INTELLECTUAL PROPERTY RIGHT, AND NO LICENSE TO ANY TECHNOLOGY OR INTELLECTUAL PROPERTY RIGHT OF TI OR ANY THIRD PARTY IS GRANTED HEREIN, including but not limited to any patent right, copyright, mask work right, or other intellectual property right relating to any combination, machine, or process in which TI products or services are used. Information regarding or referencing third-party products or services does not constitute a license to use such products or services, or a warranty or endorsement thereof. Use of TI Resources may require a license from a third party under the patents or other intellectual property of the third party, or a license from TI under the patents or other intellectual property of TI.

TI RESOURCES ARE PROVIDED "AS IS" AND WITH ALL FAULTS. TI DISCLAIMS ALL OTHER WARRANTIES OR REPRESENTATIONS, EXPRESS OR IMPLIED, REGARDING TI RESOURCES OR USE THEREOF, INCLUDING BUT NOT LIMITED TO ACCURACY OR COMPLETENESS, TITLE, ANY EPIDEMIC FAILURE WARRANTY AND ANY IMPLIED WARRANTIES OF MERCHANTABILITY, FITNESS FOR A PARTICULAR PURPOSE, AND NON-INFRINGEMENT OF ANY THIRD PARTY INTELLECTUAL PROPERTY RIGHTS.

TI SHALL NOT BE LIABLE FOR AND SHALL NOT DEFEND OR INDEMNIFY YOU AGAINST ANY CLAIM, INCLUDING BUT NOT LIMITED TO ANY INFRINGEMENT CLAIM THAT RELATES TO OR IS BASED ON ANY COMBINATION OF PRODUCTS EVEN IF DESCRIBED IN TI RESOURCES OR OTHERWISE. IN NO EVENT SHALL TI BE LIABLE FOR ANY ACTUAL, DIRECT, SPECIAL, COLLATERAL, INDIRECT, PUNITIVE, INCIDENTAL, CONSEQUENTIAL OR EXEMPLARY DAMAGES IN CONNECTION WITH OR ARISING OUT OF TI RESOURCES OR USE THEREOF, AND REGARDLESS OF WHETHER TI HAS BEEN ADVISED OF THE POSSIBILITY OF SUCH DAMAGES.

You agree to fully indemnify TI and its representatives against any damages, costs, losses, and/or liabilities arising out of your non-compliance with the terms and provisions of this Notice.

This Notice applies to TI Resources. Additional terms apply to the use and purchase of certain types of materials, TI products and services. These include; without limitation, TI's standard terms for semiconductor products (<http://www.ti.com/sc/docs/stdterms.htm>), [evaluation modules](#), and [samples](http://www.ti.com/sc/docs/sampterm.htm) (<http://www.ti.com/sc/docs/sampterm.htm>).

Mailing Address: Texas Instruments, Post Office Box 655303, Dallas, Texas 75265
Copyright © 2017, Texas Instruments Incorporated