

TOP VIEW

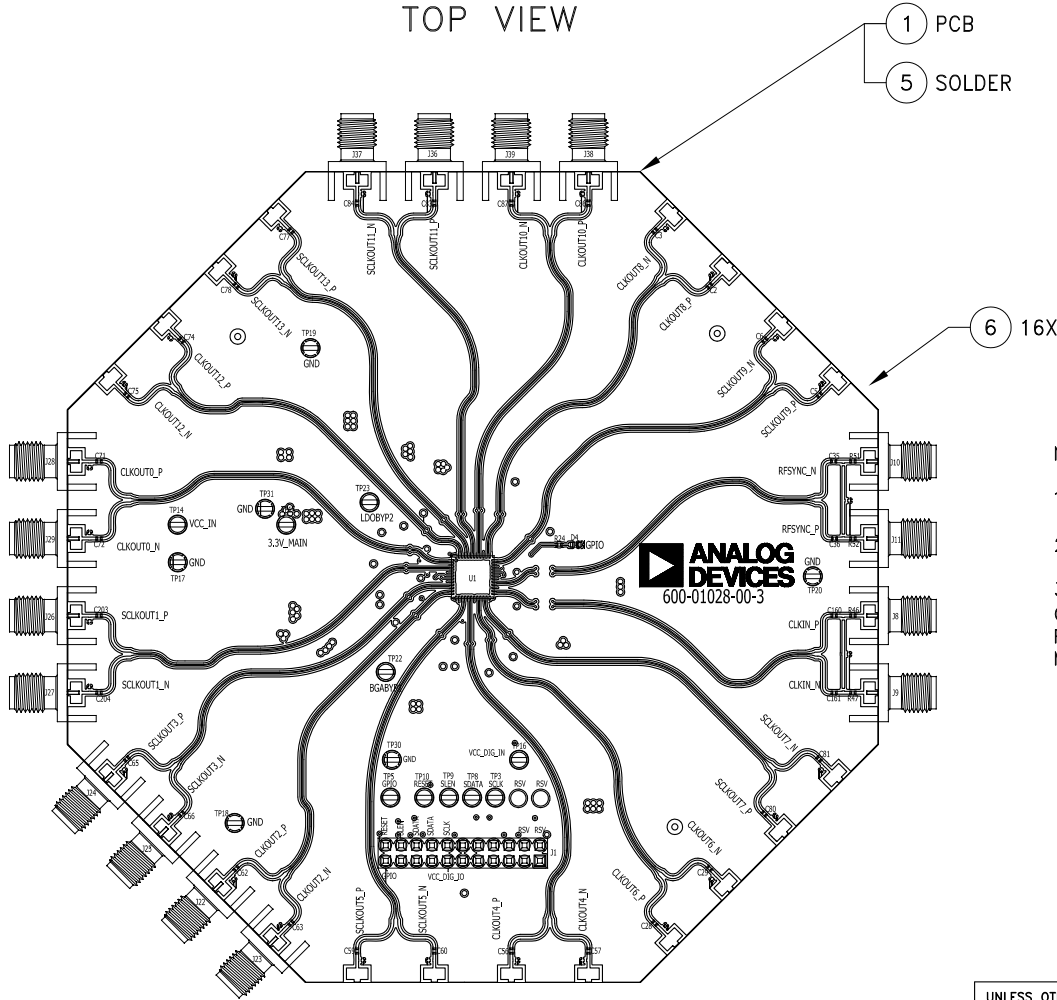

REVISION				
ZONE	LTR	DESCRIPTION	DATE	APPROVED
	A	PRODUCTION RELEASE PER CP151222	10/16/15	Y.AYDIN

NOTES:

1. SOLDER QUALITY TO IPC-A-610, CLASS 2.
2. MANUALLY DISPENSE SOLDER (ITEM 5) FOR ALL COMPONENTS.
3. J8-J11, J22-J29 AND J36-J39 ATTACH TO PCB WITH CENTER PIN ON TOPSIDE TRACE. MANUALLY DISPENSE SOLDER (ITEM 5) TO CENTER PIN AND GROUND LEADS, TOP AND BOTTOM. AFTER REFLOW, SOLDER MUST JOIN CONNECTOR AND PCB EDGE.



CAUTION!: THIS ASSEMBLY CONTAINS DEVICES THAT ARE CLASS 1A SENSITIVE TO ELECTROSTATIC DISCHARGE AND EXTREME CARE MUST BE EXERCISED. HANDLING SHALL BE PER ANSI/ESD S20.20

PROPRIETARY TO ANALOG DEVICES, INC.

UNLESS OTHERWISE SPECIFIED:	DRAWN BY Y.AYDIN	DATE DRN 08/05/15	ANALOG DEVICES 2 Elizabeth Drive Chelmsford, MA 01824 978-250-3343 Fax: 978-250-3373	
DIMENSIONS ARE IN INCHES [mm]	CHECKED BY		TITLE AD, EVAL02	
DRAWING PRACTICES PER ASME Y14.100	ENGINEER A.OZ		SIZE B	CODE ID NO. 1CN88
INTERPRET DIMENSIONS & TOLERANCES PER ASME Y14.5-2009	THIRD ANGLE PROJECTION		DWG NO. 115-01479-00	REV A
TOLERANCES: .XX ± .01 .XXX ± .005 .XXXX ± .0020 ANGLES ± .5 DEG.	DO NOT SCALE DRAWING		SCALE NTS	WT
NEXT ASSY	USED ON		SHEET	1 OF 2

