

Multi-megapixel reference designs for video surveillance



IP camera solutions enable quick product development at analog camera price points

Provided with TI's technology, several multiple highly-optimized reference designs based on DaVinci™ video processors are offered for the IP camera market that enable developers to speed through the design process as well as reducing overall bill of materials (BOM) costs.

These reference designs:

- Reduce development time by 90 percent
- Deliver higher quality, full HD video at >60 fps
- Decrease electronic bill of materials
- Empower customers to bring sub-\$100 HD IP cameras to the market
- Provide integrated auto white balance and auto exposure
- Provide software framework including input/output and media APIs, Codec Engine

Included at no additional cost:

- Complete schematics
- Gerber files

- Support for select Sony, Aptina, Panasonic, Altasens and Omnivision image sensors including drivers, camera module schematics and layout
- Complete Linux™-based IP camera application including free source code
- Royalty-free and production-ready codec
- ONVIF/PSIA standard support

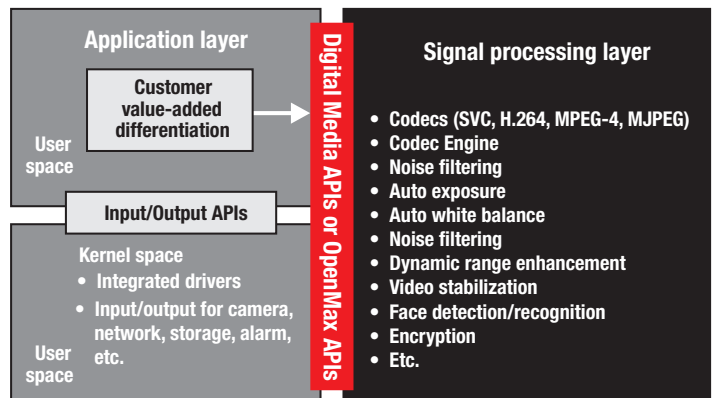

▲ TMS320DMxx-based IP Camera reference design software

Multiple IP camera reference designs available based on TI technology

- **Up to 10-Megapixel IP Camera Reference Design (TMSIPCAM385M34, TMSIPCAM8127J3):** Single platform solution provides SVC^T / H.264 4M 30 fps + SVC^T / H.264 D1 30 fps. Up to 750-MHz DSP on DM8127 processor for analytics
- **Smart Analytics IP Camera Reference Design (DMVA2IPNC-MT5):** Single-platform solution provides SVC^T / H.264 720p 30 fps + SVC^T / H.264 CIF 30 fps + smart analytics or 1080p at lower fps
- **DM36x IP Camera Reference Design (DM368IPNC-MT5, DM365IPNC-MT5):** Single-platform solution provides up to full HD (1080p30) SVC^T / H.264 30 fps encode with secondary channel
- **DM369 IP Camera Reference Design (TMSIPCAM369X104):** Single-platform solution brings best-in-class low-light performance together with 720p30 SVC^T / H.264 compression. Support for up to 1080p30 video compression performance

Order via www.ti.com/ipcamera

DM369 IP camera reference design with best-in-class low-light technology @ U.S. \$995

The DM369 IP camera reference design provides real-time Megapixel SVC^T / H.264 compression together with TI's third-generation noise filtering technology and can support 2 megapixels or higher resolution video along with advanced software for image signal-processing tuning, and encryption.

Hardware features

- TI's TMS320DM369 DaVinci™ video processor includes ARM926 @ 432 MHz and H.264 hardware video coprocessor, EMAC, RTC and integrated voice codec for BOM savings
- Board size: 65×50-mm, low power (3W)
- Power over Ethernet, audio, SD storage
- ONVIF/PSIA compliant

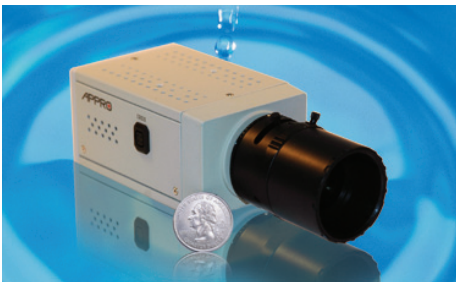

▲ TMSIPCAM369X104 IP Camera Reference Design available from Appro Photoelectron Inc.

Software features

- TI's third-generation noise filtering technology
- Encode up to H.264 high profile 720p at 30 fps together with noise filtering or 1080p at 30 fps. Higher megapixel resolutions supported at lower frame rates.
- Triple stream per channel (H.264, MPEG-4, MJPEG) and simultaneous base/main/high-profile encoding
- Ability to add video analytics with DaVinci TMS320DM643x DSP

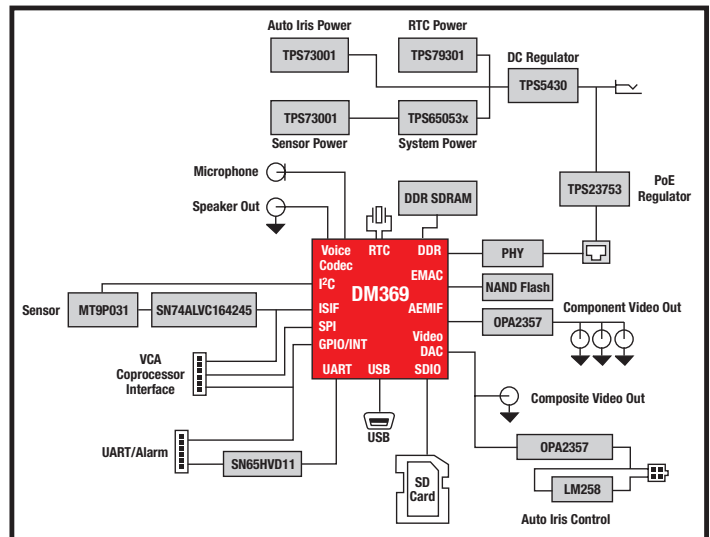

▲ IP camera reference design block diagram: TMSIPCAM369X104

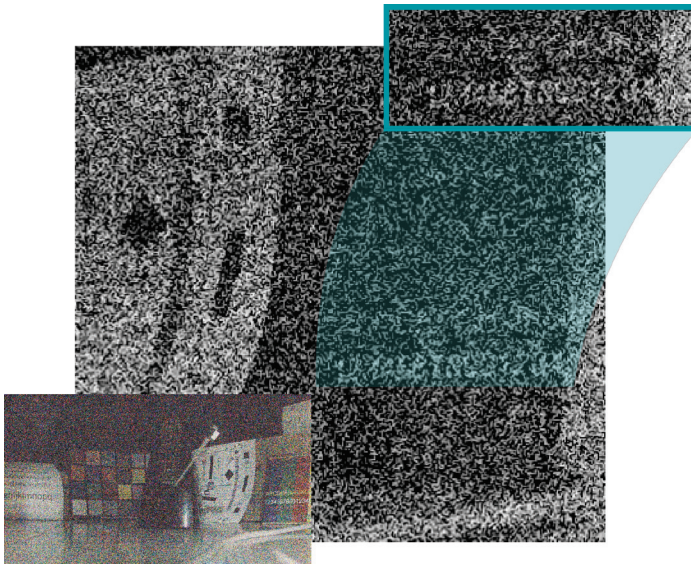

▲ Low-light scenes without noise filter

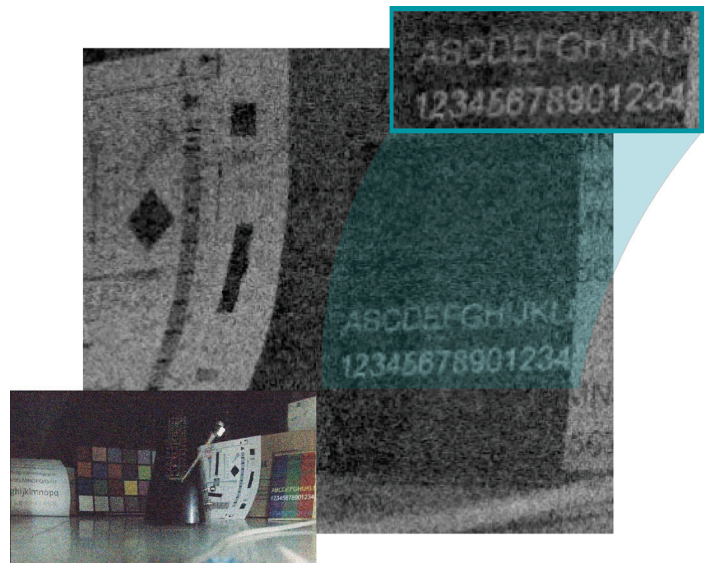

▲ Corresponding low-light scenes after TI's third-generation noise filter

DM385 IP camera reference design with H.264 high profile 4MP at 30 fps @ U.S. \$995

The DM385 IP camera reference design provides real-time 4 megapixel video, with support for 5, 6, 8, 10 and higher megapixel resolution video, advanced software for image signal processing tuning, and encryption.

Hardware features

- DM385 DaVinci™ video processor includes ARM® Cortex™-A8, SVC^T / H.264 / MJPEG video coprocessor, Gigabit EMAC, PCIe for BOM savings
- Power over Ethernet, audio, SD storage, along with WiFi™ and GPS extensibility

Software features

- TI's third-generation noise filtering engine
- Encode up to SVC^T, H.264 high profile or MJPEG 4-megapixel video at 30 fps or 1080p at 60 fps with secondary D1 channel at 30 fps



▲ TMSIPCAM385M34 Camera Reference Design available from Appro Photoelectron Inc.

- Triple stream per channel (SVC^T, H.264, MPEG-4, MJPEG)
- Software framework includes input/output and media APIs, Codec Engine
- Advanced features like face detection, video stabilization, fish eye correction

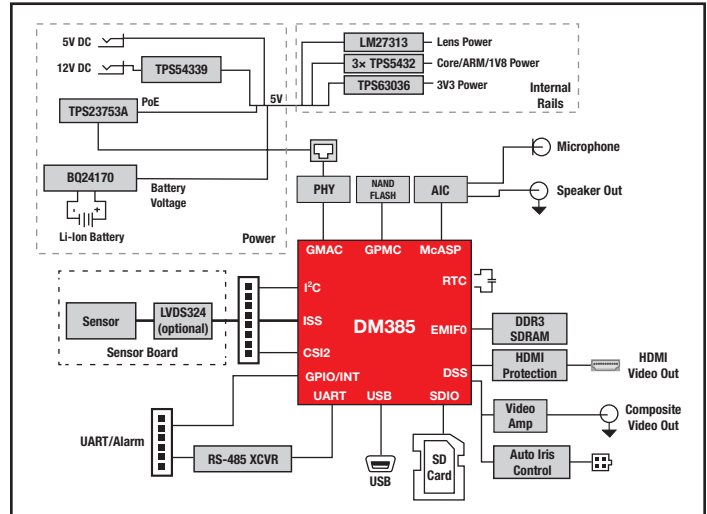

▲ DM385 IP camera reference design block diagram: TMSIPCAM385M34

DMVA2 IP camera reference design with integrated smart video analytics @ U.S. \$895

The DMVA2 IP camera reference design provides entry-level analytics including people counting, trip zone, intelligent motion detection, face detection and privacy masking, camera tamper detection, and streaming metadata.

Hardware features

- TMS320DMVA2 DaVinci video processor includes ARM926, vision coprocessor, H.264 video coprocessor, EMAC, RTC and integrated voice codec for BOM savings
- Board size: 65x50mm
- Power over Ethernet, audio, SD storage

Software features

- Smart analytics GUI for setup, control and management of each application



▲ DMVA2IPNC-MT5 IP Camera Reference Design available from Appro Photoelectron Inc.

- Encode up to H.264 high profile. Level 3.1 720p at 30 fps or 1080p at 10 fps including MPEG-4 and MJPEG support
- TI's second-generation advanced graphical user interface
- Ability to add additional video analytics with DaVinci TMS320DM643x DSP

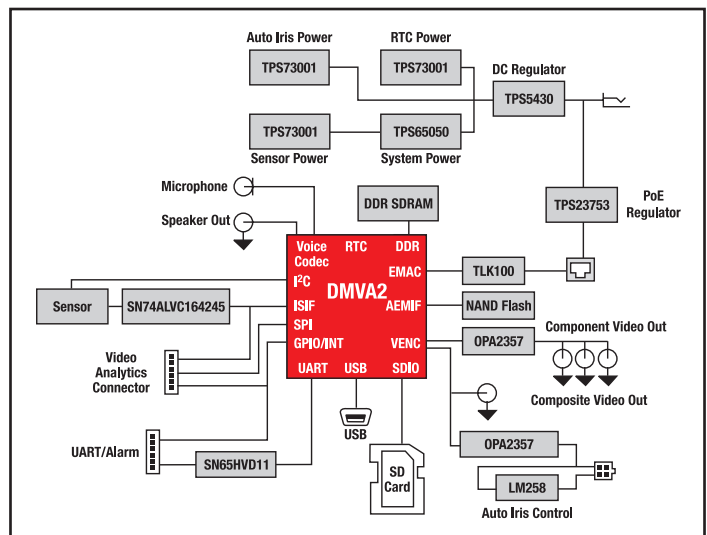

▲ DMVA2 IP camera reference design block diagram: DMVA2IPNC-MT5

DM365/DM368 IP camera reference design with H.264 high profile 1080p at 30 fps @ U.S. \$795/U.S. \$995

The DM368 IP camera reference design provides full HD video with 30 percent boost in host processing performance, advanced software for image signal processing tuning, and encryption. Offers scalable, lower cost solution with pin-to-pin compatible DM365 processor

Hardware features

- TI's TMS320DM368 DaVinci™ video processor includes ARM926 @ 486 MHz and H.264 hardware video co-processor, EMAC, RTC and integrated voice codec for BOM savings
- Board size: 65×50-mm, low power (3W)
- Power over Ethernet, audio, SD storage
- ONVIF/PSIA compliant

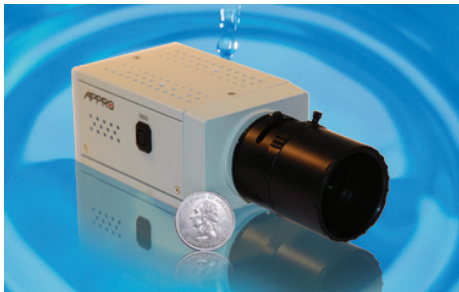

▲ DM368IPNC-MT5 IP Camera Reference Design available from Apro Photoelectron Inc.

Software features

- TI's second-generation advanced graphical user interface
- Encode up to H.264 high profile 1080p at 30 fps or 720p at 60 fps; MPEG-4 up to 720p at 60 fps; MJPEG at 5 megapixels at 15 fps
- Triple stream per channel (H.264, MPEG-4, MJPEG)
- Ability to add video analytics with DaVinci DM643x DSP

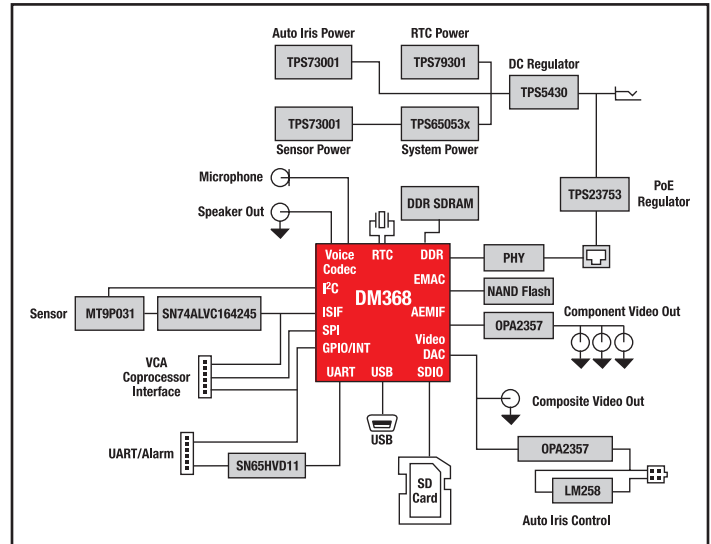

▲ IP camera reference design block diagram: DM368IPNC-MT5

DM8127 IP camera reference design with on-chip DSP video analytics @ U.S. \$995

The DM8127 IP camera reference design provides multi-megapixel video with 4× boost in host processing performance, built-in video analytics capability, advanced software for image signal processing tuning and encryption.

Hardware features

- DM8127 DaVinci™ video processor includes ARM® Cortex™-A8, C674x DSP, SVC^T/H.264/MJPEG video coprocessor, Gigabit EMAC, PCIe for BOM savings
- Board size: 100×60 mm
- Power over Ethernet, audio, SD storage, along with WiFi™ and GPS extensibility



▲ TMDXIPCAM8127J3 IP Camera Reference Design available from Apro Photoelectron Inc.

Software features

- TI's third-generation advanced graphical user interface
- Encode up to SVC^T, H.264 high profile or MJPEG 4-megapixel video at 30 fps or 1080p at 60 fps with secondary D1 channel at 30 fps
- Triple stream per channel (SVC^T, H.264, MPEG-4, MJPEG)
- Software framework includes input/output and media APIs, Codec Engine
- Onboard C674x DSP for analytics

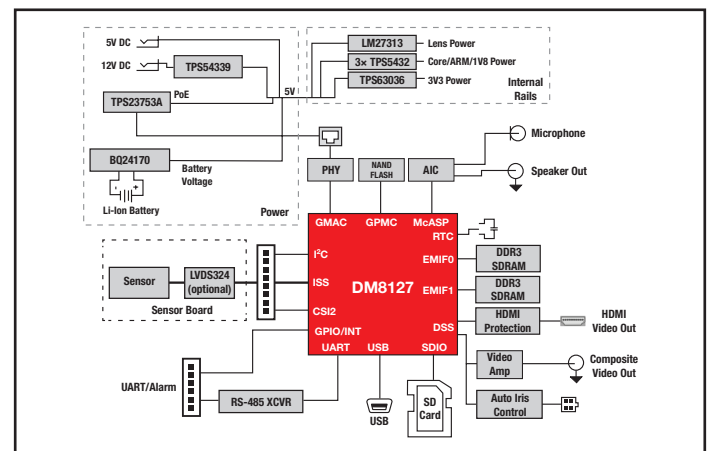

▲ DM8127 IP camera reference design block diagram: TMDXIPCAM8127J3

The platform bar and DaVinci are trademarks of Texas Instruments. All other trademarks are the property of their respective owners.

© 2013 Texas Instruments Incorporated
Printed in U.S.A. by (Printer, City, State)

IMPORTANT NOTICE

Texas Instruments Incorporated and its subsidiaries (TI) reserve the right to make corrections, enhancements, improvements and other changes to its semiconductor products and services per JESD46, latest issue, and to discontinue any product or service per JESD48, latest issue. Buyers should obtain the latest relevant information before placing orders and should verify that such information is current and complete. All semiconductor products (also referred to herein as "components") are sold subject to TI's terms and conditions of sale supplied at the time of order acknowledgment.

TI warrants performance of its components to the specifications applicable at the time of sale, in accordance with the warranty in TI's terms and conditions of sale of semiconductor products. Testing and other quality control techniques are used to the extent TI deems necessary to support this warranty. Except where mandated by applicable law, testing of all parameters of each component is not necessarily performed.

TI assumes no liability for applications assistance or the design of Buyers' products. Buyers are responsible for their products and applications using TI components. To minimize the risks associated with Buyers' products and applications, Buyers should provide adequate design and operating safeguards.

TI does not warrant or represent that any license, either express or implied, is granted under any patent right, copyright, mask work right, or other intellectual property right relating to any combination, machine, or process in which TI components or services are used. Information published by TI regarding third-party products or services does not constitute a license to use such products or services or a warranty or endorsement thereof. Use of such information may require a license from a third party under the patents or other intellectual property of the third party, or a license from TI under the patents or other intellectual property of TI.

Reproduction of significant portions of TI information in TI data books or data sheets is permissible only if reproduction is without alteration and is accompanied by all associated warranties, conditions, limitations, and notices. TI is not responsible or liable for such altered documentation. Information of third parties may be subject to additional restrictions.

Resale of TI components or services with statements different from or beyond the parameters stated by TI for that component or service voids all express and any implied warranties for the associated TI component or service and is an unfair and deceptive business practice. TI is not responsible or liable for any such statements.

Buyer acknowledges and agrees that it is solely responsible for compliance with all legal, regulatory and safety-related requirements concerning its products, and any use of TI components in its applications, notwithstanding any applications-related information or support that may be provided by TI. Buyer represents and agrees that it has all the necessary expertise to create and implement safeguards which anticipate dangerous consequences of failures, monitor failures and their consequences, lessen the likelihood of failures that might cause harm and take appropriate remedial actions. Buyer will fully indemnify TI and its representatives against any damages arising out of the use of any TI components in safety-critical applications.

In some cases, TI components may be promoted specifically to facilitate safety-related applications. With such components, TI's goal is to help enable customers to design and create their own end-product solutions that meet applicable functional safety standards and requirements. Nonetheless, such components are subject to these terms.

No TI components are authorized for use in FDA Class III (or similar life-critical medical equipment) unless authorized officers of the parties have executed a special agreement specifically governing such use.

Only those TI components which TI has specifically designated as military grade or "enhanced plastic" are designed and intended for use in military/aerospace applications or environments. Buyer acknowledges and agrees that any military or aerospace use of TI components which have **not** been so designated is solely at the Buyer's risk, and that Buyer is solely responsible for compliance with all legal and regulatory requirements in connection with such use.

TI has specifically designated certain components as meeting ISO/TS16949 requirements, mainly for automotive use. In any case of use of non-designated products, TI will not be responsible for any failure to meet ISO/TS16949.

Products

Audio	www.ti.com/audio
Amplifiers	amplifier.ti.com
Data Converters	dataconverter.ti.com
DLP® Products	www.dlp.com
DSP	dsp.ti.com
Clocks and Timers	www.ti.com/clocks
Interface	interface.ti.com
Logic	logic.ti.com
Power Mgmt	power.ti.com
Microcontrollers	microcontroller.ti.com
RFID	www.ti-rfid.com
OMAP Applications Processors	www.ti.com/omap
Wireless Connectivity	www.ti.com/wirelessconnectivity

Applications

Automotive and Transportation	www.ti.com/automotive
Communications and Telecom	www.ti.com/communications
Computers and Peripherals	www.ti.com/computers
Consumer Electronics	www.ti.com/consumer-apps
Energy and Lighting	www.ti.com/energy
Industrial	www.ti.com/industrial
Medical	www.ti.com/medical
Security	www.ti.com/security
Space, Avionics and Defense	www.ti.com/space-avionics-defense
Video and Imaging	www.ti.com/video

TI E2E Community

e2e.ti.com