



ON Semiconductor®

# FSA839 — Low-Voltage, 0.8Ω SPDT Analog Switch with Power-Off Isolation

## Features

- Power-Off Isolation ( $V_{CC}=0\text{ V}$ )
- 0.8 Ω Maximum On Resistance ( $R_{ON}$ ) for 4.5 V  $V_{CC}$
- 0.25 Ω Maximum  $R_{ON}$  Flatness for 4.5 V  $V_{CC}$
- Broad  $V_{CC}$  Operating Range: 1.65 V to 5.5 V
- Fast Turn-On and Turn-Off Times
- Control Input Switching Thresholds Independent of  $V_{CC}$
- Break-Before-Make Enable Circuitry
- 0.4 mm WLCSP Packaging
- ESD Performance
  - HBM per JESD22-A114, I/O to GND: 8 kV
  - CDM per JESD22-C101: 500 V
  - IEC61000-4-2 Contact / Air: 8 kV / 15 kV

## Description

The FSA839 is a high-performance Single-Pole / Double-Throw (SPDT) analog switch for audio applications driven by low-voltage (1.8 V) baseband processors or ASICs. The device features ultra-low  $R_{ON}$  of 0.8 Ω (maximum) at 4.5 V  $V_{CC}$  and operates over the wide  $V_{CC}$  range of 1.65 V to 5.5 V. The device is fabricated with sub-micron CMOS technology to achieve fast switching speeds and is designed for break-before-make operation.

The FSA839 interfaces between the low-voltage ASIC and regular audio amplifiers and CODECs operating up to a 5.5 V supply range. The control circuitry allows for 1.8 V (typical) signals on the control pin (Sel).

## Applications

- Cellular Phone
- Portable Media Player
- PDA

## Ordering Information

Part Number	Operating Temperature Range	Top Mark	Package	Packing Method
FSA839UCX	-40°C to +85°C	N3	6-Ball WLCSP, 0.4 mm Pitch	Tape and Reel

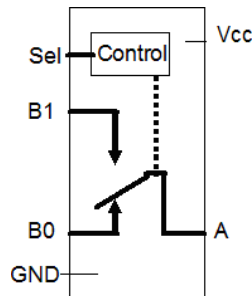
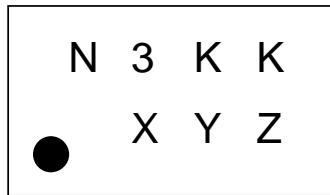

Figure 1. Analog Symbol

FSA839 — Low-Voltage, 0.8Ω SPDT Analog Switch with Power-Off Isolation

## Marking Information



KK = Lot Run Code  
 X = Year  
 Y = Work Week  
 Z = Assembly Site

Figure 2. Top Mark with Pin 1 Orientation

## Ball Configuration

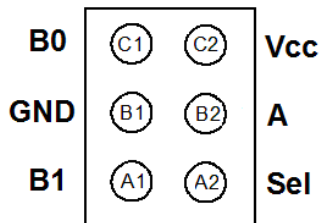

Figure 3. Pin Assignments (Bottom View)

## Ball Definitions

Ball	Name	Description
A1	B1	Data Port (Normally Open)
B1	GND	Ground
C1	B0	Data Ports (Normally Closed)
C2	V <sub>CC</sub>	Supply Voltage
B2	A	Common Data Port
A2	Sel	Control Input

## Truth Table

Control Input (Sel)	Function
LOW	B0 connected to A
HIGH	B1 connected to A

## Absolute Maximum Ratings

Stresses exceeding the absolute maximum ratings may damage the device. The device may not function or be operable above the recommended operating conditions and stressing the parts to these levels is not recommended. In addition, extended exposure to stresses above the recommended operating conditions may affect device reliability. The absolute maximum ratings are stress ratings only.

Symbol	Parameter		Min.	Max.	Unit
$V_{CC}$	Supply Voltage		-0.5	6.5	V
$V_{SW}$	Switch Voltage <sup>(1)</sup>		-0.5	$V_{CC} + 0.5$	V
$V_{IN}$	Input Voltage <sup>(1)</sup>		-0.5	6.5	V
$I_{IK}$	Input Diode Current			-50	mA
$I_{SW}$	Switch Current (Continuous)			200	mA
$I_{SWPEAK}$	Peak Switch Current (Pulsed at 1 ms Duration, <10% Duty Cycle)			400	mA
$P_D$	Power Dissipation at 85°C			180	mW
$T_{STG}$	Storage Temperature Range		-65	+150	°C
$T_J$	Maximum Junction Temperature			+150	°C
$T_L$	Lead Temperature (Soldering, 10 Seconds)			+260	°C
ESD	Human Body Model (JEDEC: JESD22-A114)	I/O to GND: A		8	kV
		All Pins		2	
	Charged Device Model (JEDEC: JESD22-C101)			500	V
	Machine Model (JEDEC: JESD22-A115)			100	V
	IEC6100-4-2 Discharge System Test Performed on ON Semiconductor's FSA859 Applications Testing Board	Contact		8	kV
		Air		15	

### Note:

- The input and output negative ratings may be exceeded if the input and output diode current ratings are observed.

## Recommended Operating Conditions

The Recommended Operating Conditions table defines the conditions for actual device operation. Recommended operating conditions are specified to ensure optimal performance to the datasheet specifications. ON Semiconductor does not recommend exceeding them or designing to Absolute Maximum Ratings.

Symbol	Parameter	Min.	Max.	Unit
$V_{CC}$	Supply Voltage	1.65	5.50	V
SEL	Control Input Voltage	0	1.95	V
$V_{SW}$	Switch Input Voltage	0	$V_{CC}$	V
$T_A$	Operating Temperature	-40	+85	°C
$\theta_{JA}$	Thermal Resistance, Still Air		350	°C/W

## DC Electrical Characteristics

All typical values are at 25°C unless otherwise specified.

Symbol	Parameter	V <sub>CC</sub> (V)	Conditions	T <sub>A</sub> =+25°C			T <sub>A</sub> =-40 to +85°C		Unit
				Min.	Typ.	Max.	Min.	Max.	
V <sub>IH</sub>	Input Voltage High	1.65 to 5.50					1.0		V
V <sub>IL</sub>	Input Voltage Low	1.65 to 5.50						0.57	V
I <sub>IN</sub>	Control Input Leakage	1.95 to 5.50	V <sub>SEL</sub> =0	-2		2	-20	20	nA
I <sub>NO(OFF)</sub> , I <sub>NC(OFF)</sub>	Off-Leakage Current of Port B0 and B1 <sup>(5)</sup>	5.50	A=1 V, 4.5 V B0 or B1=4.5, 1 V	-10		10	-50	50	nA
		3.60	A=1 V, 3.0V B0 or B1=3.0, 1V	-10		10	-50	50	
		2.70	A=0.5 V, 2.3 V B0 or B1=2.3, 0.5V	-10		10	-50	50	
		1.95	A=0.3 V, 1.65 V B0 or B1=1.65, 0.3 V	-5		5	-20	20	
I <sub>NO(ON)</sub> , I <sub>NC(ON)</sub>	On-Leakage Current of Port B0 and B1 <sup>(5)</sup>	5.50	A=Floating B0 or B1=4.5, 1V	-20		20	-100	100	nA
		3.60	A=Floating B0 or B1=3.0, 1 V	-10		10	-20	20	
		2.70	A=Floating B0 or B1=2.3, 0.5 V	-10		10	-20	20	
		1.95	A=Floating B0 or B1=1.65, 0.3 V	-5		5	-20	20	
I <sub>A(ON)</sub>	On Leakage Current of Port A <sup>(5)</sup>	5.50	A=1 V, 4.5 V; B0 or B1=1 V, 4.5 V, or Floating	-20		20	-100	100	nA
		3.60	A=1V, 3.0VB0 or B1=1V, 3.0V, or Floating	-10		10	-20	20	
		2.70	A=0.5 V, 2.3 V, B0 or B1=0.5 V, 2.3 V, or Floating	-10		10	-20	20	
		1.95	A=0.3 V, 1.65 V; B0 or B1=0.3 V, 1.65 V, or Floating	-5		5	-20	20	
I <sub>OFF</sub>	Power Off Leakage Current of Port A & Port B <sup>(5)</sup>	0	A=0 to 5.5 V B0 or B1=0 to 5.5 V	-1.00	0.01	1.00	-5.00	5.00	μA
R <sub>PD</sub>	Internal Pull-Down Resistor	1.65 to 1.95			2.0				MΩ
I <sub>CC</sub>	Quiescent Supply Current	5.50	V <sub>IN</sub> , V <sub>SEL</sub> =0 or V <sub>CC</sub> , I <sub>OUT</sub> =0			100		500	nA

		3.60	$V_{IN}, V_{SEL} = 0 \text{ or } V_{CC},$ $I_{OUT} = 0$			75		300	
		2.70	$V_{IN}, V_{SEL} = 0 \text{ or } V_{CC},$ $I_{OUT} = 0$			50		250	
		1.95	$V_{IN}, V_{SEL} = 0 \text{ or } V_{CC},$ $I_{OUT} = 0$			25		150	

*Continued on the following page...*

### DC Electrical Characteristics (Continued)

All typical values are at 25°C unless otherwise specified.

Symbol	Parameter	V <sub>CC</sub> (V)	Conditions	T <sub>A</sub> =+25°C			T <sub>A</sub> =-40 to +85°C		Unit
				Min.	Typ.	Max.	Min.	Max.	
I <sub>CC</sub> T	Increase in I <sub>CC</sub> per Control Input	5.50	V <sub>SEL</sub> = 1.8 V		26	40		50	μA
		3.60	V <sub>SEL</sub> = 1.8 V		5	15		20	
		2.70	V <sub>SEL</sub> = 1.8 V		1	5		10	
		1.95	V <sub>SEL</sub> = 1.8 V		0.01	1.00		3.00	
I <sub>CC</sub> Z	Supply Current Sleep	5.50	V <sub>IN</sub> , V <sub>SEL</sub> = Floating			0.5		1.0	μA
R <sub>ON</sub>	Switch On Resistance <sup>(2,5)</sup>	4.50	I <sub>OUT</sub> =-100 mA, B0 or B1=2.5 V		0.50	0.75		0.80	Ω
		3.00	I <sub>OUT</sub> =-100 mA, B0 or B1=2.0 V		0.75	0.90		1.20	
		2.25	I <sub>OUT</sub> =-100 mA, B0 or B1=1.8 V		1.0	1.3		1.6	
		1.65	I <sub>OUT</sub> =-100 mA, B0 or B1=1.2 V		2.5	5.0		7.0	
ΔR <sub>ON</sub>	On Resistance Matching Between Channels <sup>(3,5)</sup>	4.50	I <sub>OUT</sub> =-100 mA, B0 or B1=2.5 V		0.05	0.10		0.10	Ω
		3.00	I <sub>OUT</sub> =-100 mA, B0 or B1=2.0 V		0.10	0.15		0.15	
		2.25	I <sub>OUT</sub> =-100 mA, B0 or B1=1.8 V		0.15	0.20		0.20	
		1.65	I <sub>OUT</sub> =-100 mA, B0 or B1=1.2 V		0.15	0.40		0.40	
R <sub>FLAT(ON)</sub>	On Resistance Flatness <sup>(4,5)</sup>	4.50	I <sub>OUT</sub> =-100 mA, B0 or B1=1.0V, 1.5 V, 2.5 V		0.075	0.250		0.250	Ω
		3.00	I <sub>OUT</sub> =-100 mA, B0 or B1=0.8 V, 2.0 V		0.1	0.3		0.3	
		2.25	I <sub>OUT</sub> =-100 mA, B0 or B1=0.8 V, 1.8 V		0.25	0.50		0.60	
		1.65	I <sub>OUT</sub> =-100mA, B0 or B1=0.6 V, 1.2 V		3.5				

**Notes:**

2. On resistance is determined by the voltage drop between A and B pins at the indicated current through the switch.
3. ΔR<sub>ON</sub>=R<sub>ON</sub> maximum – R<sub>ON</sub> minimum; measured at identical V<sub>CC</sub>, temperature, and voltage.
4. Flatness is defined as the difference between the maximum and minimum value of on resistance over the specified range of conditions.
5. Guaranteed by characterization, not production tested for V<sub>CC</sub>=1.65 – 1.95 V.

## AC Electrical Characteristics

All typical values are at  $V_{CC}=1.8\text{ V}$ ,  $2.5\text{ V}$ ,  $3.0\text{ V}$ , and  $5.0\text{ V}$  at  $25^\circ\text{C}$  unless otherwise specified.

Symbol	Parameter	$V_{CC}$ (V)	Conditions	$T_A=+25^\circ\text{C}$			$T_A=-40$ to $+85^\circ\text{C}$		Unit	Figure
				Min.	Typ.	Max.	Min.	Max.		
$t_{ON}$	Turn-On Time <sup>(6)</sup>	4.50 to 5.50	$B0$ or $B1=V_{CC}$ , $R_L=50\ \Omega$ , $C_L=35\text{ pF}$	1.0	12.0	25.0	1.0	30.0	ns	Figure 4
		3.00 to 3.60		5.0	15.0	30.0	3.0	35.0		
		2.30 to 2.70		5.0	20.0	35.0	5.0	40.0		
		1.65 to 1.95		10.0	50.0	70.0	10.0	75.0		
$t_{OFF}$	Turn-Off Time <sup>(6)</sup>	4.50 to 5.50	$B0$ or $B1=V_{CC}$ , $R_L=50\ \Omega$ , $C_L=35\text{ pF}$	1.0	9.5	20.0	1.0	25.0	ns	Figure 4
		3.00 to 3.60		1.0	9.0	20.0	1.0	25.0		
		2.30 to 2.70		2.0	10.0	20.0	2.0	25.0		
		1.65 to 1.95		2.0	28.0	40.0	2.0	50.0		
$t_{BBM}$	Break-Before-Make Time <sup>(7)</sup>	4.50 to 5.50	$B0$ or $B1=V_{CC}/2$ , $R_L=50\ \Omega$ , $C_L=35\text{ pF}$	1.0	10.0	12.0	0.1	14.0	ns	Figure 5
		3.00 to 3.60		1.0	14.0	16.0	1.0	17.0		
		2.30 to 2.70		1.0	21.0	25.0	1.0	27.0		
		1.65 to 1.95			35.0		2.0	50.0		
Q	Charge Injection	5.50	$C_L=1.0\text{ nF}$ , $V_{GEN}=0\text{ V}$ , $R_{GEN}=0\ \Omega$		70				pC	Figure 7
		3.30			40					
		2.50			30					
		1.65			10					
OIRR	Off Isolation	1.8 to 5.0	$f=1\text{ MHz}$ , $R_L=50\ \Omega$		-55				dB	Figure 6
Xtalk	Crosstalk	1.8 to 5.0	$f=1\text{ MHz}$ , $R_L=50\ \Omega$		55				dB	Figure 6
BW	-3 db Bandwidth	5.50	$R_L=50\ \Omega$		60				MHz	Figure 9
		3.30			60					
		2.50			55					
		1.65			50					
THD	Total Harmonic Distortion	1.80	$R_L=600\ \Omega$ , $V_{IN}=0.5\text{ V}_{PP}$ , $f=20\text{ Hz}$ to $20\text{ kHz}$		.02				%	Figure 10
		5.00			.001					
PSRR	Power Supply Rejection Ratio	3.3	$f=217\text{ Hz}$ on $V_{CC}$ at $500\text{ mVpp}$		-23				dB	Figure 11

**Notes:**

6. Guaranteed by characterization, not production tested for  $V_{CC}=1.65 - 1.95\text{ V}$ .
7. Guaranteed by characterization, not production tested.

### Capacitance

Symbol	Parameter	V <sub>CC</sub> (V)	Conditions	T <sub>A</sub> =+25°C			Unit
				Min.	Typ.	Max.	
C <sub>IN</sub>	Control Pin Input Capacitance	0	f=1 MHz		3.2		pF
C <sub>OFF</sub>	B Port Off Capacitance	1.65 to 5.50	f=1 MHz		50		pF
C <sub>ON</sub>	A Port On Capacitance	1.65 to 5.50	f=1 MHz		150		pF

### Test Diagrams

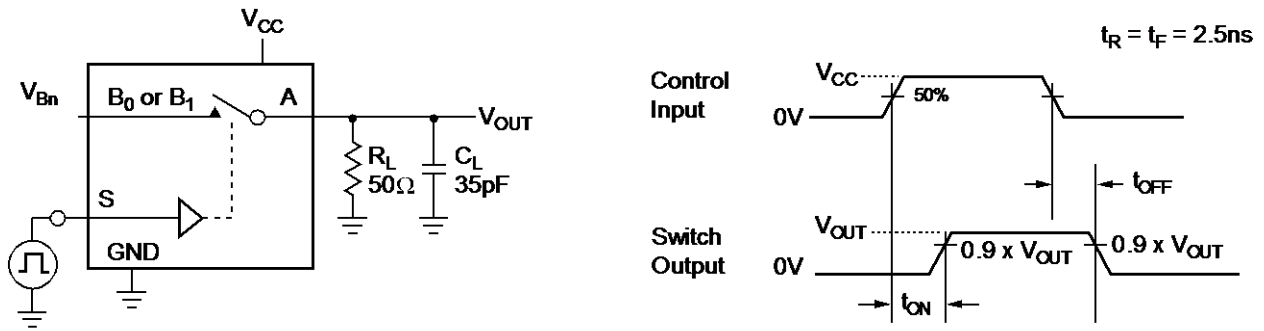

$C_L$  includes fixture and stray capacitance.

Logic input waveforms inverted for switches that have the opposite logic sense.

Figure 4. Turn On / Off Timing

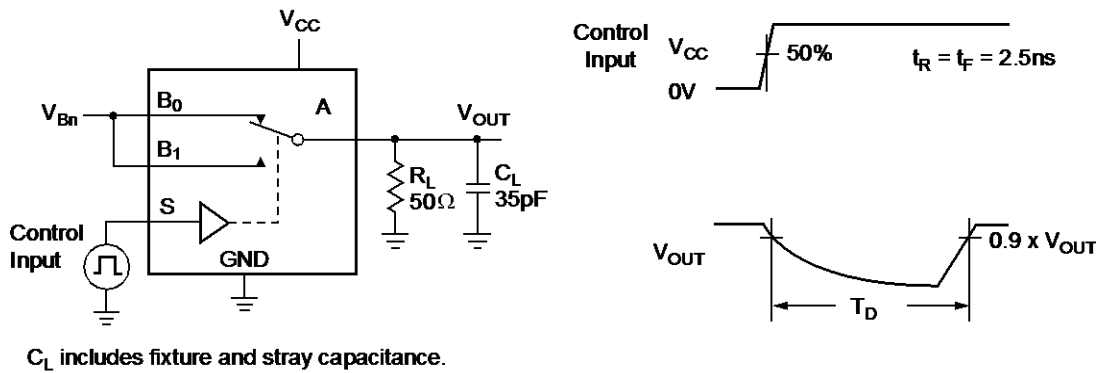

$C_L$  includes fixture and stray capacitance.

Figure 5. Break-Before-Make Timing

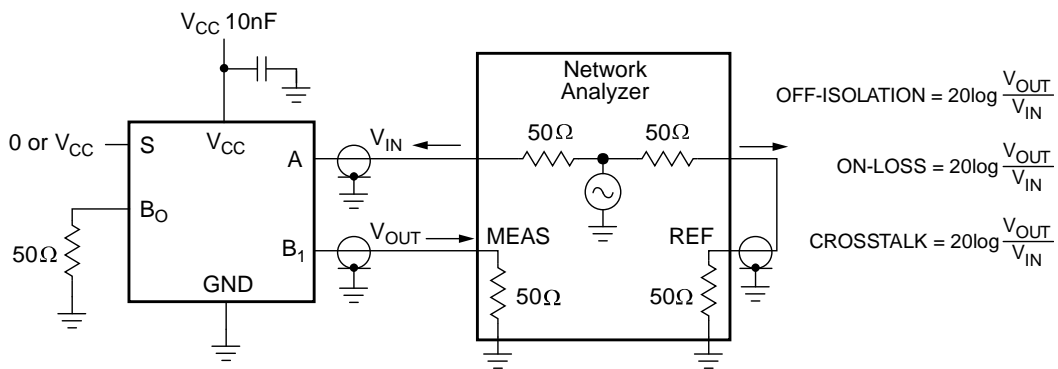

Figure 6. Off Isolation and Crosstalk

Test Diagrams (Continued)

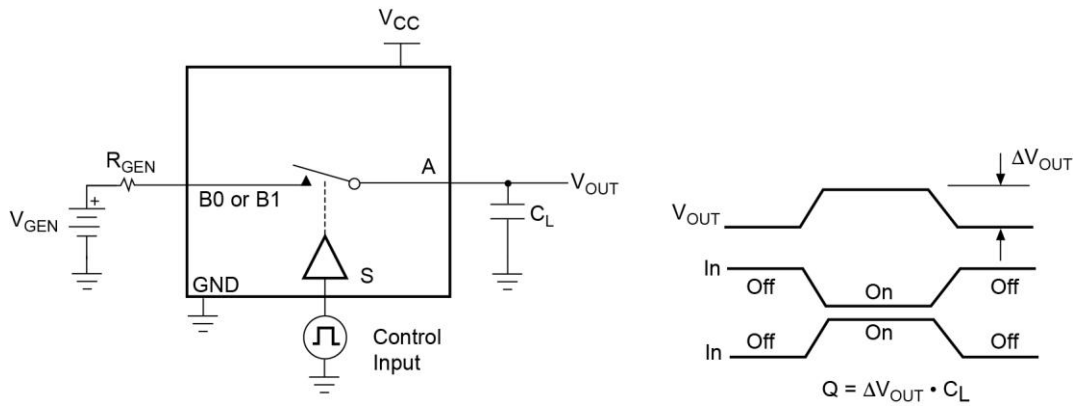

Figure 7. Charge Injection

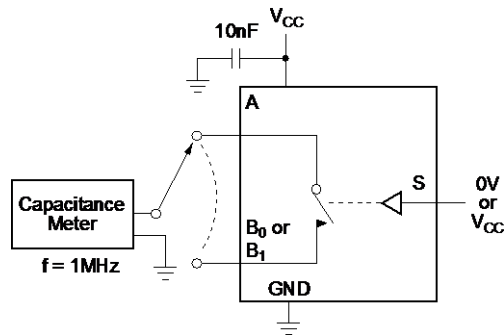

Figure 8. On / Off Capacitance Measurement Setup

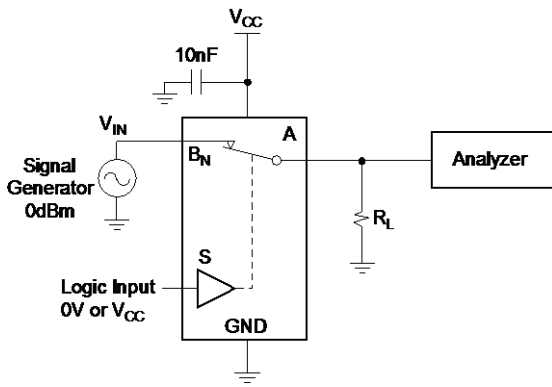

Figure 9. Bandwidth

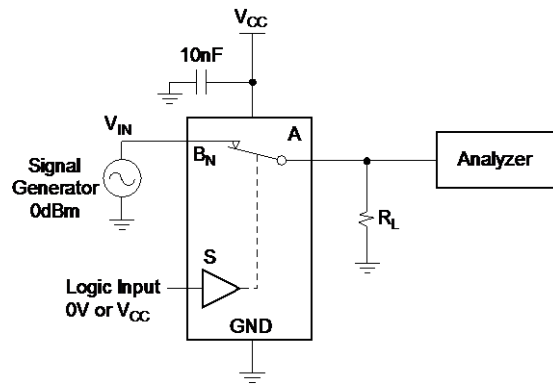

Figure 10. Harmonic Distortion

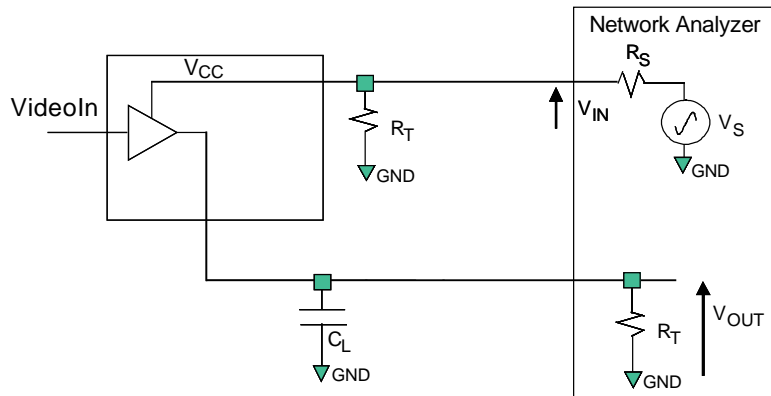
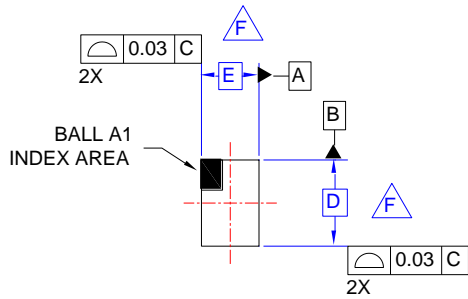

Figure 11. PSRR

### Product Specific Dimensions

Product	D	E	X	Y
FSA839UCX	1.160 ±.030	0.760 ±.030	0.180	0.180

### Physical Dimensions



TOP VIEW

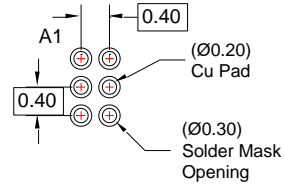

RECOMMENDED LAND PATTERN  
(NSMD PAD TYPE)

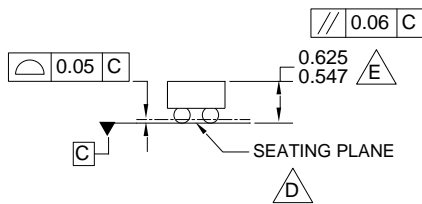

SIDE VIEWS

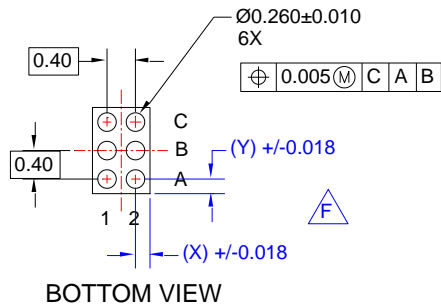
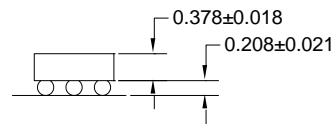

BOTTOM VIEW

#### NOTES:

- A. NO JEDEC REGISTRATION APPLIES.
- B. DIMENSIONS ARE IN MILLIMETERS.
- C. DIMENSIONS AND TOLERANCES PER ASMEY14.5M, 1994.
- D. DATUM C, THE SEATING PLANE IS DEFINED BY THE SPHERICAL CROWNS OF THE BALLS.
- E. PACKAGE TYPICAL HEIGHT IS 586 MICRONS ±39 MICRONS (547-625 MICRONS).
- F. FOR DIMENSIONS D, E, X, AND Y SEE PRODUCT DATASHEET.
- G. DRAWING FILENAME: UC006ACrev4.

Figure 12. 6-Ball, WLCSP 0.4 mm Pitch

ON Semiconductor and the ON Semiconductor logo are trademarks of Semiconductor Components Industries, LLC dba ON Semiconductor or its subsidiaries in the United States and/or other countries. ON Semiconductor owns the rights to a number of patents, trademarks, copyrights, trade secrets, and other intellectual property. A listing of ON Semiconductor's product/patent coverage may be accessed at [www.onsemi.com/site/pdf/Patent-Marking.pdf](http://www.onsemi.com/site/pdf/Patent-Marking.pdf). ON Semiconductor reserves the right to make changes without further notice to any products herein. ON Semiconductor makes no warranty, representation or guarantee regarding the suitability of its products for any particular purpose, nor does ON Semiconductor assume any liability arising out of the application or use of any product or circuit, and specifically disclaims any and all liability, including without limitation special, consequential or incidental damages. Buyer is responsible for its products and applications using ON Semiconductor products, including compliance with all laws, regulations and safety requirements or standards, regardless of any support or applications information provided by ON Semiconductor. "Typical" parameters which may be provided in ON Semiconductor data sheets and/or specifications can and do vary in different applications and actual performance may vary over time. All operating parameters, including "Typicals" must be validated for each customer application by customer's technical experts. ON Semiconductor does not convey any license under its patent rights nor the rights of others. ON Semiconductor products are not designed, intended, or authorized for use as a critical component in life support systems or any FDA Class 3 medical devices or medical devices with a same or similar classification in a foreign jurisdiction or any devices intended for implantation in the human body. Should Buyer purchase or use ON Semiconductor products for any such unintended or unauthorized application, Buyer shall indemnify and hold ON Semiconductor and its officers, employees, subsidiaries, affiliates, and distributors harmless against all claims, costs, damages, and expenses, and reasonable attorney fees arising out of, directly or indirectly, any claim of personal injury or death associated with such unintended or unauthorized use, even if such claim alleges that ON Semiconductor was negligent regarding the design or manufacture of the part. ON Semiconductor is an Equal Opportunity/Affirmative Action Employer. This literature is subject to all applicable copyright laws and is not for resale in any manner.

## PUBLICATION ORDERING INFORMATION

### LITERATURE FULFILLMENT:

Literature Distribution Center for ON Semiconductor  
19521 E. 32nd Pkwy, Aurora, Colorado 80011 USA

Phone: 303-675-2175 or 800-344-3860 Toll Free

USA/Canada

Fax: 303-675-2176 or 800-344-3867 Toll Free USA/Canada

Email: [orderlit@onsemi.com](mailto:orderlit@onsemi.com)

**N. American Technical Support:** 800-282-9855 Toll

Free

USA/Canada.

**Europe, Middle East and Africa Technical Support:**

Phone: 421 33 790 2910

**Japan Customer Focus Center**

Phone: 81-3-5817-1050

**ON Semiconductor Website:** [www.onsemi.com](http://www.onsemi.com)

**Order Literature:** <http://www.onsemi.com/orderlit>

For additional information, please contact your local  
Sales Representative