

UG123: SiOCXO1-EVB Evaluation Board User's Guide

The Silicon Labs SiOCXO1-EVB (kit) is used to help evaluate Silicon Labs Jitter Attenuator and Network Synchronization products for Stratum 3/3E, IEEE 1588 and G.8262 SyncE applications.

EVB FEATURES:

- Flexible Output Termination
- Power Supply Filtering
- Optional Output Buffer
- Optional OCXO Voltage Control Adjust

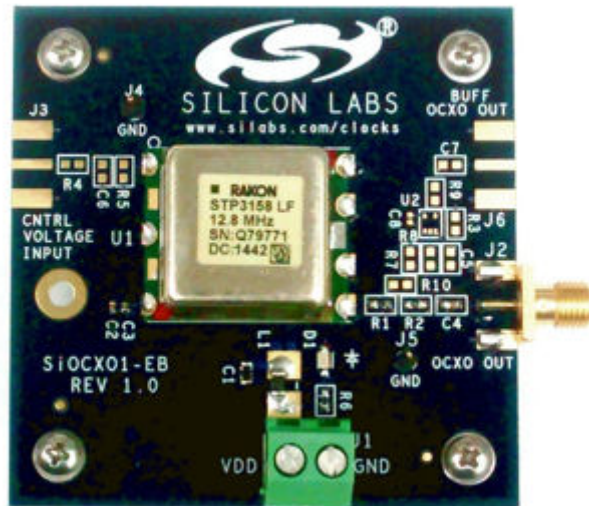

Figure .1. SiOCXO1-EB

1. Quick Start

Refer to [Figure 3.1 Functional Block Diagram on page 4](#), [Figure 3.2 SiOCXO1-EB Shown Populated with an OCXO on page 4](#), and [Figure 4.1 SiOCXO1-EB Configured with Si5348 EVB on page 6](#) to clarify the instructions below.

1. Connect power to J1, and note that start-up current could be on the order of 1 amp. Check the manufacturers warm-up time.
2. Connect SiOCXO1-EB output, J2, to the Si5348 REF clock input using the short SMA cable provided with the EVB kit.

2. Top Layer View of Board

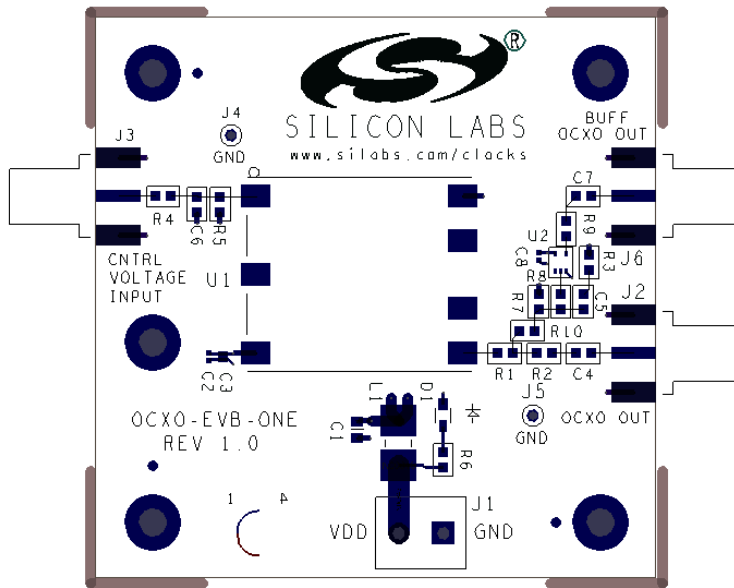

Figure 2.1. Top Layer View of Board

3. Functional Description

The SiOCXO1-EB is used in conjunction with Silicon Labs precision timing devices to facilitate characterization. The SiOCXO1-EB was designed to maximize output termination configurations as well as optional control voltage terminations. Resistors and capacitors are 0603, which makes it simple to remove and add various values. The SiOCXO1-EB bill of materials and PCB layouts are in Section 7. [Bill of Materials](#) and Section 6. [Schematic](#). The block diagram for the board is provided below:

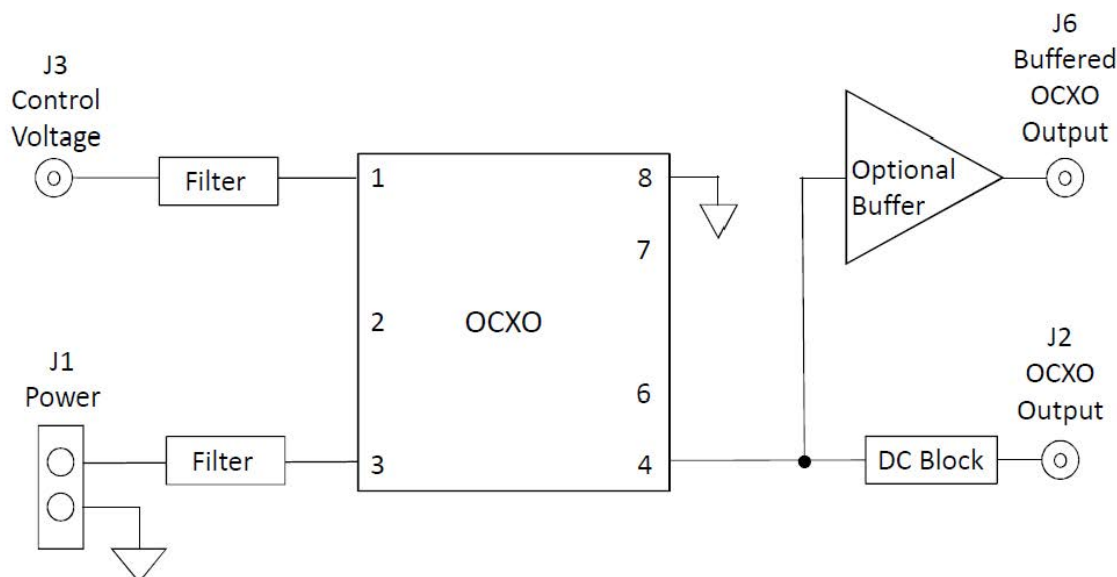

Figure 3.1. Functional Block Diagram

The SiOCXO1-EB is intended to be a general use board for a 7-pin OCXO with 22x25 nominal package size, such as the Rakon P/N STP3158 12.8 MHz pictured below. See Section 6. [Schematic](#) for example measurements carried out using this OCXO.

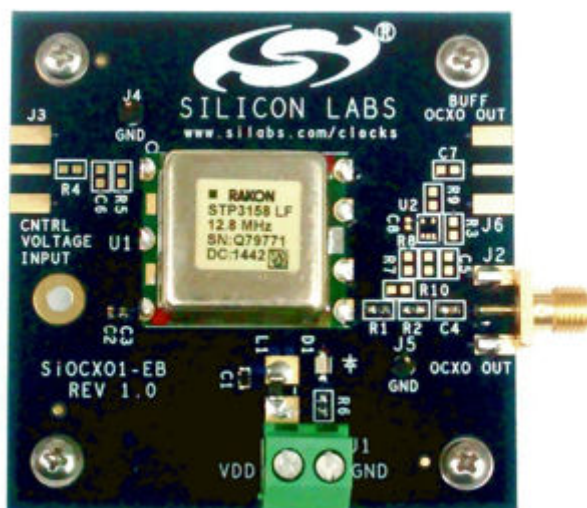

Figure 3.2. SiOCXO1-EB Shown Populated with an OCXO

3.1 Power Supply

The power supply voltage and current requirements are listed in the manufacturers data sheet. A 3.3 V $\pm 5\%$ supply is required. R6 may require modification if other voltages are used. Also, note the OCXO initial current can be on the order of 1A. Power supply filtering has been added to the evaluation board to minimize spurious response.

3.2 Output Termination and Optional Buffer

In most applications simple R C termination is used, as seen with R1 and C4 in [Figure 6.1 SiOCXO1-EB Schematic on page 8](#). This is a resistor to optimize impedance matching and a capacitor to block DC. Modifications can be made as required.

Optionally a buffer can be added to minimize loading on the OCXO's output, such as when driving cables. In this case U2, J6, C7, C8, R8, and R9 must be populated, while R2 can be depopulated.

3.3 Optional OCXO Frequency Adjust

Some OCXO's have an optional control voltage to adjust the output frequency, usually by a small amount such as 1 or 2 ppm. One example would be to discipline the OCXO to reduce the effects of OCXO aging. In this case, J3 and R4 must be populated as a minimum. C6 can be used for filtering or BW frequency limiting. Alternatively, R5 and C6 could be fixed or adjustable resistors to set a DC bias voltage.

4. Configuring the SiOCXO-EB

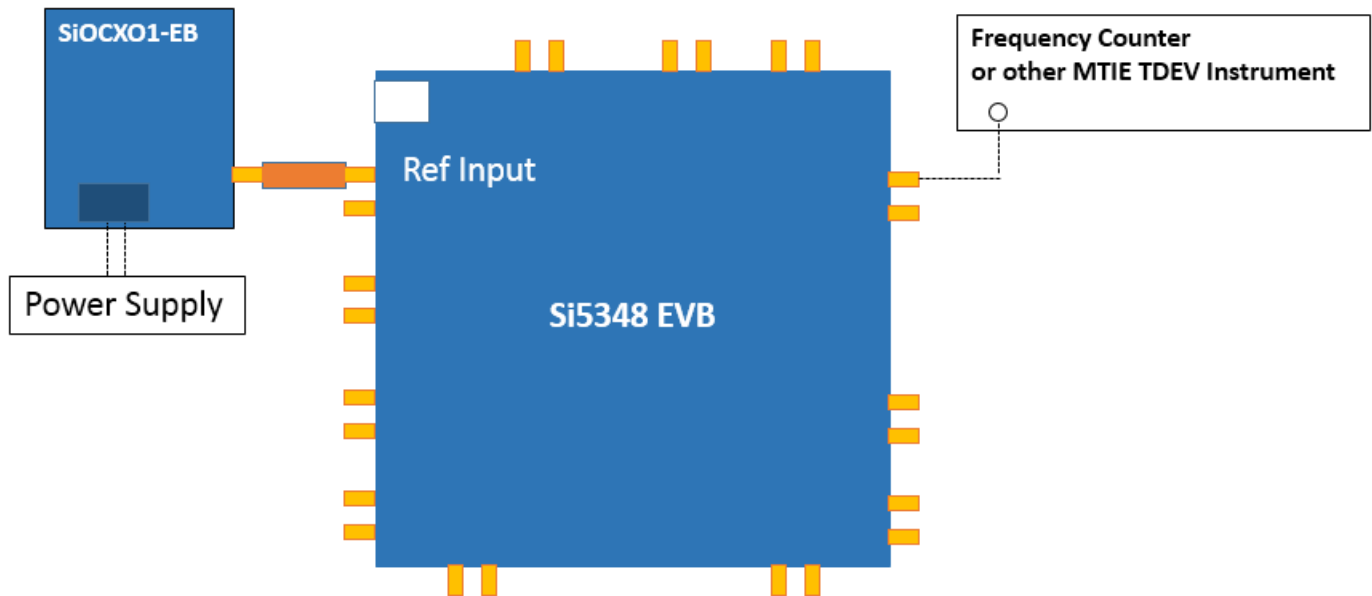

Figure 4.1. SiOCXO1-EB Configured with Si5348 EVB

The connection between the SiOCXO-EB and Si5348 EVB should be kept as short as possible. It is recommended to use a UPS Power Supply back-up for long term testing.

5. SiOCXO1-EB Functionality Test

1. Connect power to J1 (3.3 V).
2. Connect SiOCXO1-EB Output, J2, to an oscilloscope (terminate into 50 Ω).
3. Verify that the red LED is illuminated, the current draw matches closely to the specs, and the output matches the OCXO's data sheet.

5.1 Example Measurement Results Using STP3158LF 12.8 MHz OCXO from Rakon

Table 5.1. Current Specs for Rakon P/N STP3158 12.8 MHz at U1

Example Current Draw	Expected Value (Data Sheet)	Example Measured Value
Warm-up	≤ 0.9 A	0.72 A
Steady State	≤ 0.3 A	0.29 A

Notes on Current Settling:

1. The system (including the LED and OCXO) initially drew 0.72–0.74 A of current from the 3.3 V power supply. At one minute, the current draw slightly decreased by 0.02–0.04A (warm-up time). Around the minute mark the current decreased rapidly to 0.32–0.37A. Then, the system decreased slightly to its consistent steady state current of 0.30 A within 20 minutes.
2. The LED draws around 10 mA, so subtract this from the power supply (system) current to get the current draw of the OCXO alone. These are the values reflected in the table above.

Steady State Output Waveform for Rakon P/N STP3158 12.8 MHz at U1

Verify the output is a 12.8 MHz LVCMOS waveform. For example, measure with a Tektronix TDS 20245, 200 MHz oscilloscope terminated with 50 Ω BNC T connector.

6. Schematic

Notes on U1 Layout:

- 1) U1 should be located close to J2.
- 2) Do not route traces underneath U1.
- 3) Do not place planes (copper pours) underneath the U1.
- 4) R7, R8 and C5 should be placed as to minimize stubs on the Fout to J2 trace.
- 5) R5, C6 should be placed as to minimize stubs on the J3 to VC trace.

Normally Not Populated

Control Voltage Circuit: J3, R4, C6, R5
Output Buffer: R8, C8, U2, R9, C7, J6
Output Termination: R7, C5, R3

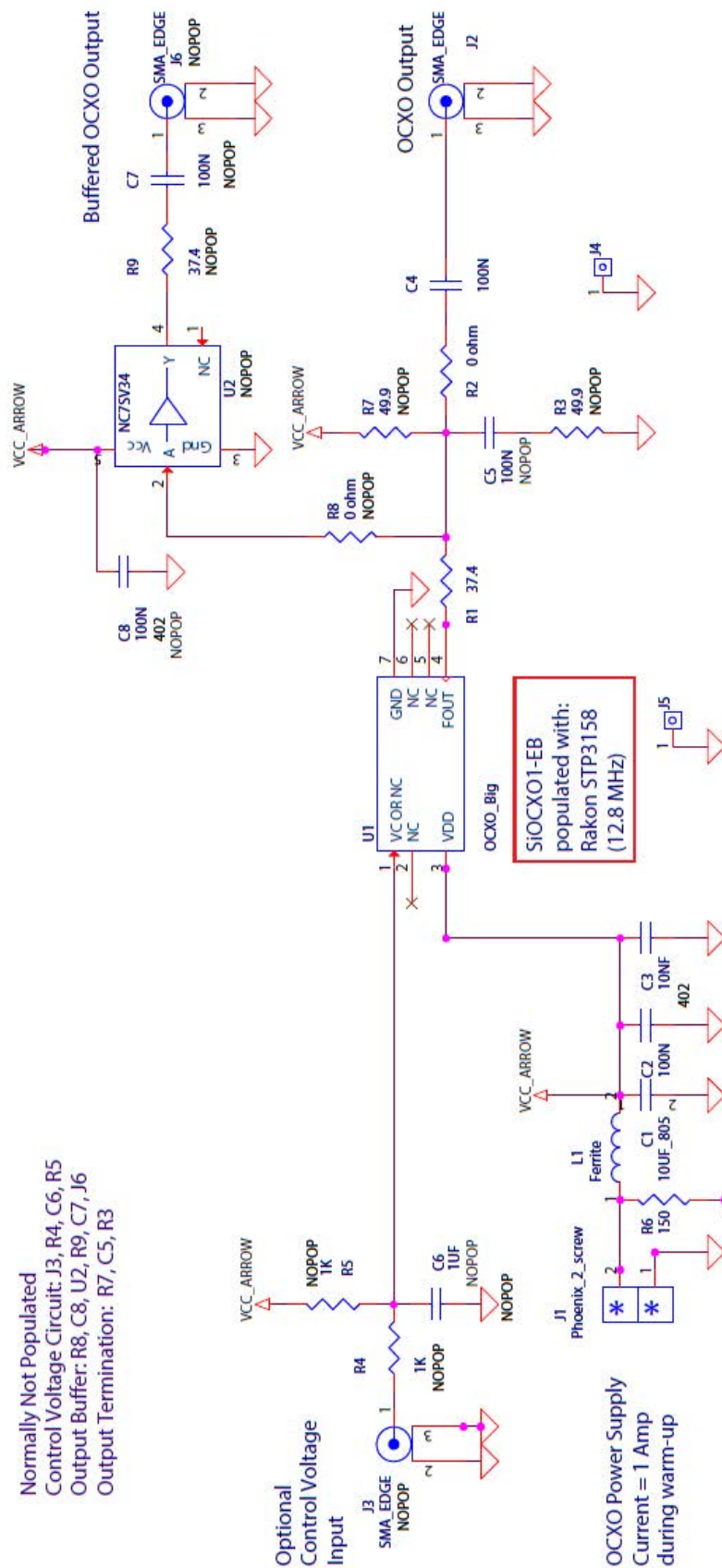

Figure 6.1. SiOCXO1-EB Schematic

7. Bill of Materials

Table 7.1. SiOCXO1-EB Bill of Materials

Item	Quantity	Reference	Part	Manufacturer	Manufacturer Part Number	BOM	Digikey	Footprint	Comment
1	1	C1	10UF_805	Venkel	C0805Y5V6R3106ZN			805	
2	2	C2,C8	100N	Venkel	C0402X7R6R3-104KNE			402	
3	1	C3	10NF	Venkel	LIC0204X6S6R3-103MNE			204	
4	2	C4,C5	100N	Venkel	C0603X7R160-104KNE			603	
7	1	D1	Red	Panasonic	LN1271RAL		P493CT-ND	LED_gull_flip	
8	5	H1,H2,H3,H4,H5	HOLE_NUM4					plated-Num4hole	
9	1	J1	Phoenix_2_screw	Phoenix	MKDSN1.5/2-5.08		277-1247-ND	Phoenix2pinM_p2pitch	
10	1	J2	SMA_EDGE	Johnson	142-0701-801		J502-ND	SMA_EDGE_p062	
12	2	J4,J5	Jmpr_1pin					1pin_p1pitch	
13	1	L1	Ferrite	Steward	HI1612X560R-10			1612	
14	1	R1	37.4	Venkel	CR0603-16W-37R4FT			603	
15	1	R2	0 ohm	Venkel	CR0603-16W-000T			603	
18	1	R6	150	Venkel	CR0603-16W-1500FT			603	
21	1	U1	12.8 MHz	Rakon	STP3158				Alternate = Connor Winfield OH300-50503CF-0 12.8M or AVX OO12.8000000M1 4070AT
5	1	C6	1UF	Venkel	C0603X7R6R3-105KNE	NO-POP		603	

Item	Quantity	Reference	Part	Manufacturer	Manufacturer Part Number	BOM	Digikey	Footprint	Comment
6	1	C7	100N	Venkel	C0603X7R160-104KNE	NO-POP		603	
11	2	J3,J6	SMA_EDGE	Johnson	142-0701-801	NO-POP	J502-ND	SMA_EDGE_p062	
16	2	R3,R7	49.9	Venkel	CR0603-16W-49R9FT	NO-POP		603	
17	2	R4,R5	1K	Venkel	CR0603-16W-1001FT	NO-POP		603	
19	2	R8,R10	0 ohm	Venkel	CR0603-16W-000T	NO-POP		603	
20	1	R9	37.4	Venkel	CR0603-16W-37R4FT	NO-POP		603	
22	1	U2	NC7SV34	Fairchild	NC7SV34P5X	NO-POP	NC7SV34P5X-ND	SC-70-5	Alternate = Fairchild NC7SZ126M5X

Note: The OCXO must be populated if it is not.

8. Layout

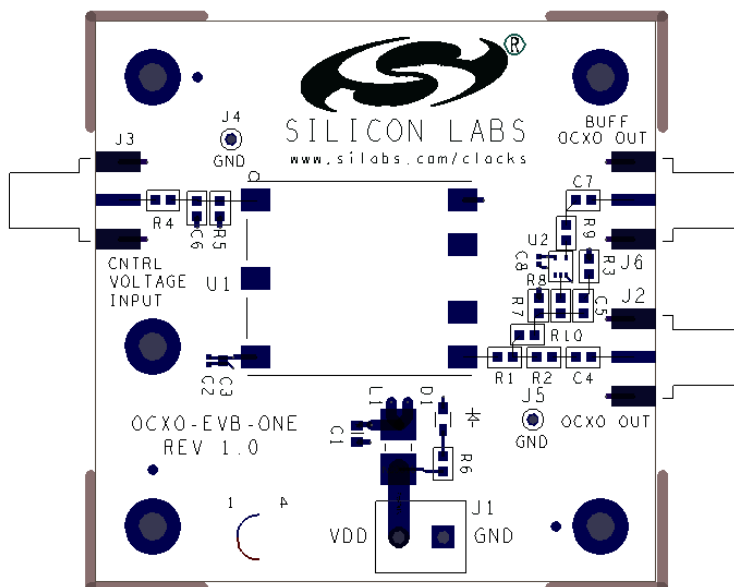

Figure 8.1. Layer 1: Primary Side

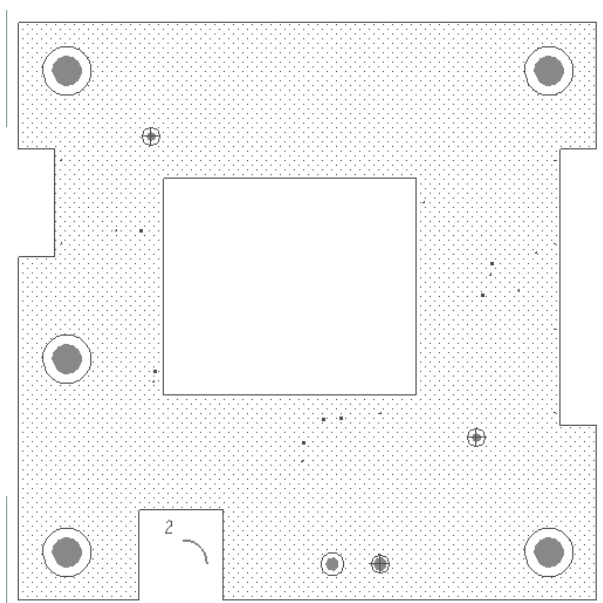

Figure 8.2. Layer 2: Ground

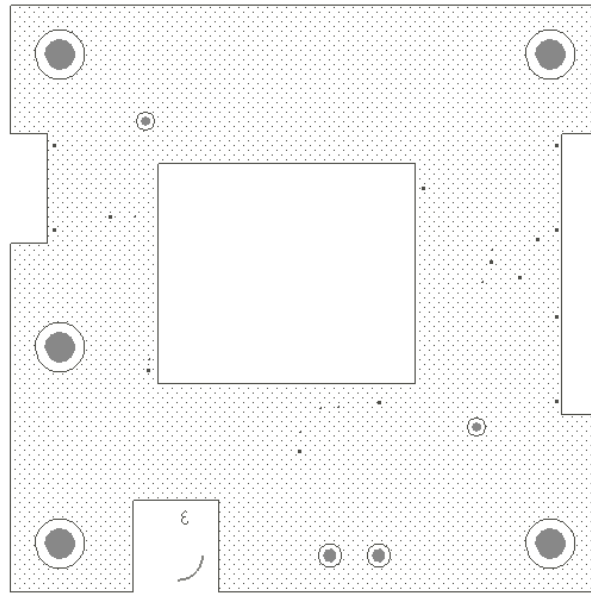

Figure 8.3. Layer 3: Power

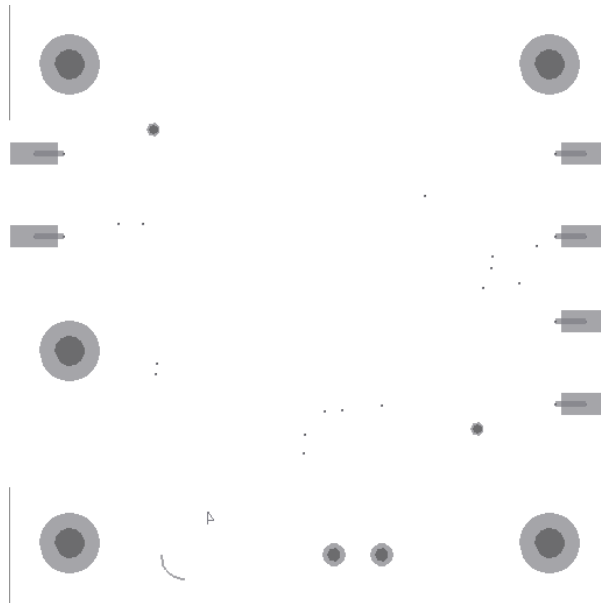

Figure 8.4. Layer 4: Secondary Side



ClockBuilder Pro

One-click access to Timing tools, documentation, software, source code libraries & more. Available for Windows and iOS (CBGo only).

www.silabs.com/CBPro



Timing Portfolio
www.silabs.com/timing



SW/HW
www.silabs.com/CBPro



Quality
www.silabs.com/quality



Support and Community
community.silabs.com

Disclaimer

Silicon Labs intends to provide customers with the latest, accurate, and in-depth documentation of all peripherals and modules available for system and software implementers using or intending to use the Silicon Labs products. Characterization data, available modules and peripherals, memory sizes and memory addresses refer to each specific device, and "Typical" parameters provided can and do vary in different applications. Application examples described herein are for illustrative purposes only. Silicon Labs reserves the right to make changes without further notice and limitation to product information, specifications, and descriptions herein, and does not give warranties as to the accuracy or completeness of the included information. Silicon Labs shall have no liability for the consequences of use of the information supplied herein. This document does not imply or express copyright licenses granted hereunder to design or fabricate any integrated circuits. The products are not designed or authorized to be used within any Life Support System without the specific written consent of Silicon Labs. A "Life Support System" is any product or system intended to support or sustain life and/or health, which, if it fails, can be reasonably expected to result in significant personal injury or death. Silicon Labs products are not designed or authorized for military applications. Silicon Labs products shall under no circumstances be used in weapons of mass destruction including (but not limited to) nuclear, biological or chemical weapons, or missiles capable of delivering such weapons.

Trademark Information

Silicon Laboratories Inc.®, Silicon Laboratories®, Silicon Labs®, SiLabs® and the Silicon Labs logo®, Bluegiga®, Bluegiga Logo®, Clockbuilder®, CMEMS®, DSPLL®, EFM®, EFM32®, EFR, Ember®, Energy Micro, Energy Micro logo and combinations thereof, "the world's most energy friendly microcontrollers", Ember®, EZLink®, EZRadio®, EZRadioPRO®, Gecko®, ISOModem®, Micrium, Precision32®, ProSLIC®, Simplicity Studio®, SiPHY®, Telegesis, the Telegesis Logo®, USBXpress®, Zentri, Z-Wave, and others are trademarks or registered trademarks of Silicon Labs. ARM, CORTEX, Cortex-M3 and THUMB are trademarks or registered trademarks of ARM Holdings. Keil is a registered trademark of ARM Limited. All other products or brand names mentioned herein are trademarks of their respective holders.



Silicon Laboratories Inc.
400 West Cesar Chavez
Austin, TX 78701
USA

<http://www.silabs.com>