

TPS61175 3-A High-Voltage Boost Converter With Soft Start and Programmable Switching Frequency

1 Features

- 2.9-V to 18-V Input voltage range
- 3-A, 40-V Internal switch
- High-efficiency power conversion: Up to 93%
- Frequency set by external resistor: 200 kHz to 2.2 MHz
- Synchronous external switching frequency
- User-defined soft start into full load
- Skip-switching cycle for output regulation at light load
- 14-Pin HTSSOP package with PowerPad™
- Create a custom design using the TPS61175 with the [WEBENCH Power Designer](#)

2 Applications

- 5-V to 12-V, 24-V Power conversion
- Supports SEPIC and flyback topologies
- ADSL modems
- TV tuners

3 Description

The TPS61175 device is a monolithic switching regulator with integrated 3-A, 40-V power switch. The device can be configured in several standard switching-regulator topologies, including boost, SEPIC, and flyback. The device has a wide input voltage range to support application with input voltage from multicell batteries or regulated 5-V, 12-V power rails.

The TPS61175 regulates the output voltage with current mode pulse width modulation (PWM) control. The switching frequency of PWM is set by either an external resistor or an external clock signal. The user can program the switching frequency from 200 kHz to 2.2 MHz.

The device features a programmable soft-start function to limit inrush current during start-up, and has other built-in protection features, such as pulse-by-pulse overcurrent limit and thermal shutdown. The TPS61175 is available in 14-pin HTSSOP package with PowerPad.

Device Information⁽¹⁾

PART NUMBER	PACKAGE	BODY SIZE (NOM)
TPS61175	HTSSOP (14)	5.00 mm x 4.40 mm

(1) For all available packages, see the orderable addendum at the end of the data sheet.

Simplified Schematic

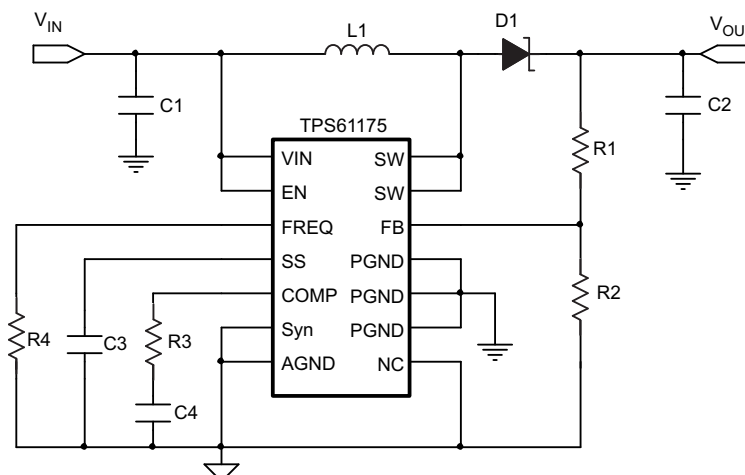

Copyright © 2016, Texas Instruments Incorporated



Table of Contents

1 Features	1	8 Application and Implementation	12
2 Applications	1	8.1 Application Information.....	12
3 Description	1	8.2 Typical Application	12
4 Revision History	2	9 Power Supply Recommendations	20
5 Pin Configuration and Functions	3	10 Layout	20
6 Specifications	4	10.1 Layout Guidelines	20
6.1 Absolute Maximum Ratings	4	10.2 Layout Example	20
6.2 ESD Ratings.....	4	10.3 Thermal Considerations	21
6.3 Recommended Operating Conditions.....	4	11 Device and Documentation Support	22
6.4 Thermal Information	5	11.1 Device Support.....	22
6.5 Electrical Characteristics.....	5	11.2 Development Support	22
6.6 Typical Characteristics.....	6	11.3 Receiving Notification of Documentation Updates	22
7 Detailed Description	8	11.4 Community Resources.....	22
7.1 Overview	8	11.5 Trademarks	22
7.2 Functional Block Diagram	8	11.6 Electrostatic Discharge Caution.....	22
7.3 Feature Description.....	9	11.7 Glossary	23
7.4 Device Functional Modes.....	11	12 Mechanical, Packaging, and Orderable Information	23

4 Revision History

Changes from Revision E (February 2019) to Revision F Page

- Changed Soft Start figure reference to point to the correct soft start waveform. 9
- Changed "≤" sign in [Equation 7](#) to "≥"

Changes from Revision D (April 2016) to Revision E Page

- Changed *Handling Ratings* table to [ESD Ratings](#); moved Storage Temperature to [Absolute Maximum Ratings](#)
- Updated symbols in [Thermal Information](#)
- Added the $I_{IN(MAX)}$ for the $I_{OUT(max)}$ calculation equation.

Changes from Revision C (August 2014) to Revision D Page

- Revised second paragraph of *Minimum ON Time and Pulse Skipping* section or clarity.

Changes from Revision B (February 2012) to Revision C Page

- Added *Handling Rating* table, *Feature Description* section, *Device Functional Modes*, *Application and Implementation* section, *Power Supply Recommendations* section, *Layout* section, *Device and Documentation Support* section, and *Mechanical, Packaging, and Orderable Information* section.....

Changes from Revision A (October 2010) to Revision B Page

- Replaced the Dissipation Ratings Table with the Thermal Information Table.....

Changes from Original (December 2008) to Revision A Page

- Changed the Ordering Information table - Part Number From: TPS61175 To: TPS61175PWP; Removed the Package Marking column

5 Pin Configuration and Functions

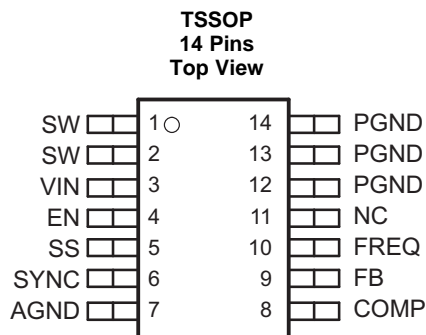

Pin Functions

PIN		I/O	DESCRIPTION
NAME	NO.		
AGND	7	I	Signal ground of the IC
COMP	8	O	Output of the internal transconductance error amplifier. An external RC network is connected to this pin to compensate the regulator.
EN	4	I	Enable pin. When the voltage of this pin falls below the enable threshold for more than 10ms, the IC turns off.
FB	9	I	Feedback pin for positive voltage regulation. Connect to the center tap of a resistor divider to program the output voltage.
FREQ	10	O	Switch frequency program pin. An external resistor is connected to this pin to set switch frequency. See application section for information on how to size the FREQ resistor.
NC	11	I	Reserved pin. Must connect this pin to ground.
PGND	12,13,14	I	Power ground of the IC. It is connected to the source of the PWM switch.
SS	5	O	Soft start programming pin. A capacitor between the SS pin and GND pin programs soft start timing. See Application and Implementation for information on how to size the SS capacitor.
SW	1,2	I	This is the switching node of the IC. Connect SW to the switched side of the inductor.
SYNC	6	I	Switch frequency synchronous pin. Customers can use an external signal to set the IC switch frequency between 200-kHz and 2.2-MHz. If not used, this pin should be tied to AGND as short as possible to avoid noise coupling.
Thermal Pad			The thermal pad should be soldered to the analog ground. If possible, use thermal via to connect to top and internal ground plane layers for ideal power dissipation.
VIN	3	I	The input supply pin for the IC. Connect VIN to a supply voltage between 2.9 V and 18 V. It is acceptable for the voltage on the pin to be different from the boost power stage input for applications requiring voltage beyond VIN range.

6 Specifications

6.1 Absolute Maximum Ratings

over operating free-air temperature range (unless otherwise noted)⁽¹⁾

	MIN	MAX	UNIT
Supply voltages on pin VIN ⁽²⁾	-0.3	20	V
Voltages on pins EN ⁽²⁾	-0.3	20	V
Voltage on pin FB, FREQ and COMP ⁽²⁾	-0.3	3	V
Voltage on pin SYNC, SS ⁽²⁾	-0.3	7	V
Voltage on pin SW ⁽²⁾	-0.3	40	V
Continuous power dissipation	See Thermal Information		
Operating junction temperature range	-40	150	°C
Storage temperature, T _{stg}	-65	150	°C

- (1) Stresses beyond those listed under *absolute maximum ratings* may cause permanent damage to the device. These are stress ratings only and functional operation of the device at these or any other conditions beyond those indicated under *recommended operating conditions* is not implied. Exposure to absolute-maximum-rated conditions for extended periods may affect device reliability.
- (2) All voltage values are with respect to network ground terminal.

6.2 ESD Ratings

			VALUE	UNIT
V _(ESD)	Electrostatic discharge	Human-body model (HBM), per ANSI/ESDA/JEDEC JS-001 ⁽¹⁾	±2000	V
		Charged-device model (CDM), per JEDEC specification JESD22-C101 ⁽²⁾	±500	

- (1) JEDEC document JEP155 states that 500-V HBM allows safe manufacturing with a standard ESD control process.
- (2) JEDEC document JEP157 states that 250-V CDM allows safe manufacturing with a standard ESD control process.

6.3 Recommended Operating Conditions

over operating free-air temperature range (unless otherwise noted)

		MIN	NOM	MAX	UNIT
V _{IN}	Input voltage	2.9		18	V
V _O	Output voltage	V _{IN}		38	V
L	Inductor ⁽¹⁾	4.7		47	μH
f _{SW}	Switching frequency	200		2200	kHz
C _I	Input capacitor	4.7			μF
C _O	Output capacitor	4.7			μF
V _{SYN}	External switching frequency logic			5	V
T _A	Operating ambient temperature	-40		85	°C
T _J	Operating junction temperature	-40		125	°C

- (1) The inductance value depends on the switching frequency and end application. While larger values may be used, values between 4.7-μH and 47-μH have been successfully tested in various applications. Refer to [Selecting the Inductor](#) for detail.

6.4 Thermal Information

THERMAL METRIC ⁽¹⁾		TPS61175	UNIT
		PWP (HTSSOP)	
		14 PINS	
R _{θJA}	Junction-to-ambient thermal resistance	45.2	°C/W
R _{θJC(top)}	Junction-to-case (top) thermal resistance	34.9	°C/W
R _{θJB}	Junction-to-board thermal resistance	30.1	°C/W
ψ _{JT}	Junction-to-top characterization parameter	1.5	°C/W
ψ _{JB}	Junction-to-board characterization parameter	29.9	°C/W
R _{θJC(bot)}	Junction-to-case (bottom) thermal resistance	5.8	°C/W

(1) For more information about traditional and new thermal metrics, see the *Semiconductor and IC Package Thermal Metrics* application report (SPRA953).

6.5 Electrical Characteristics

FSW = 1.2 MHz (R_{freq} = 80 kΩ), V_{IN} = 3.6 V, T_A = -40°C to +85°C, typical values are at T_A = 25°C (unless otherwise noted)

PARAMETER		TEST CONDITIONS	MIN	TYP	MAX	UNIT
SUPPLY CURRENT						
V _{IN}	Input voltage range		2.9		18	V
I _Q	Operating quiescent current into Vin	Device PWM switching without load			3.5	mA
I _{SD}	Shutdown current	EN=GND			1.5	μA
V _{UVLO}	Under-voltage lockout threshold			2.5	2.7	V
V _{hys}	Under-voltage lockout hysteresis			130		mV
ENABLE AND REFERENCE CONTROL						
V _{enh}	EN logic high voltage	V _{IN} = 2.9 V to 18 V	1.2			V
V _{enl}	EN logic low voltage	V _{IN} = 2.9 V to 18 V			0.4	V
V _{SYNh}	SYN logic high voltage		1.2			
V _{SYNl}	SYN logic low voltage				0.4	V
R _{en}	EN pull down resistor		400	800	1600	kΩ
T _{off}	Shutdown delay, SS discharge	EN high to low	10			ms
VOLTAGE AND CURRENT CONTROL						
V _{REF}	Voltage feedback regulation voltage		1.204	1.229	1.254	V
I _{FB}	Voltage feedback input bias current				200	nA
I _{sink}	Comp pin sink current	V _{FB} = V _{REF} + 200 mV, V _{COMP} = 1 V		50		μA
I _{source}	Comp pin source current	V _{FB} = V _{REF} - 200 mV, V _{COMP} = 1 V		130		μA
V _{CCLP}	Comp pin clamp voltage	High Clamp, V _{FB} = 1 V Low Clamp, V _{FB} = 1.5 V		3 0.75		V
V _{CTH}	Comp pin threshold	Duty cycle = 0%		0.95		V
G _{ea}	Error amplifier transconductance		240	340	440	μmho
R _{ea}	Error amplifier output resistance			10		MΩ
f _{ea}	Error amplifier crossover frequency			500		KHz

Electrical Characteristics (continued)

FSW = 1.2 MHz ($R_{freq} = 80\text{ k}\Omega$), $V_{IN} = 3.6\text{ V}$, $T_A = -40^\circ\text{C}$ to $+85^\circ\text{C}$, typical values are at $T_A = 25^\circ\text{C}$ (unless otherwise noted)

PARAMETER		TEST CONDITIONS	MIN	TYP	MAX	UNIT
FREQUENCY						
f_S	Oscillator frequency	$R_{freq} = 480\text{ k}\Omega$	0.16	0.21	0.26	MHz
		$R_{freq} = 80\text{ k}\Omega$	1.0	1.2	1.4	
		$R_{freq} = 40\text{ k}\Omega$	1.76	2.2	2.64	
D_{max}	Maximum duty cycle	$V_{FB} = 1\text{ V}$, $R_{freq} = 80\text{ k}\Omega$	89%	93%		
V_{FREQ}	FREQ pin voltage			1.229		V
T_{min_on}	Minimum on pulse width	$R_{freq} = 80\text{ k}\Omega$		60		ns
POWER SWITCH						
$R_{DS(ON)}$	N-channel MOSFET on-resistance	$V_{IN} = V_{GS} = 3.6\text{ V}$ $V_{IN} = V_{GS} = 3.0\text{ V}$		0.13 0.13	0.25 0.3	Ω
I_{LN_NFET}	N-channel leakage current	$V_{DS} = 40\text{ V}$, $T_A = 25^\circ\text{C}$			1	μA
OC, OVP AND SS						
I_{LIM}	N-Channel MOSFET current limit	$D = D_{max}$	3	3.8	5	A
I_{SS}	Soft start bias current	$V_{SS} = 0\text{ V}$		6		μA
THERMAL SHUTDOWN						
$T_{shutdown}$	Thermal shutdown threshold			160		$^\circ\text{C}$
$T_{hysteresis}$	Thermal shutdown threshold hysteresis			15		$^\circ\text{C}$

6.6 Typical Characteristics

Circuit of [Figure 1](#); $L1 = D104C2-10\mu\text{H}$; $D1 = SS3P6L-E3/86A$, $R4 = 80\text{ k}\Omega$, $R3 = 10\text{ k}\Omega$, $C4 = 22\text{ nF}$, $C2 = 10\mu\text{F}$; $V_{IN} = 5\text{ V}$, $V_{OUT} = 24\text{ V}$, $I_{OUT} = 200\text{ mA}$ (unless otherwise noted)

Table 1. Table Of Graphs

		FIGURE
Efficiency	$V_{IN} = 5\text{ V}$, $V_{OUT} = 12\text{ V}, 24\text{ V}, 35\text{ V}$	Figure 1
Efficiency	$V_{IN} = 5\text{ V}, 12\text{ V}$; $V_{OUT} = 24\text{ V}$	Figure 2
Error amplifier transconductance	vs Temperature	Figure 3
Switch current limit	vs Temperature	Figure 4
Switch current limit	vs Duty cycle	Figure 5
FB accuracy	vs Temperature	Figure 6
Line transient response	$V_{IN} = 4.5\text{ V}$ to 5 V	Figure 12
Load transient response	$I_{OUT} = 100\text{ mA}$ to 300 mA ; refer to 'compensating the control loop' for optimization	Figure 13
PWM Operation		Figure 14
Pulse skipping	No load	Figure 15
Start-up	$C3 = 47\text{ nF}$	Figure 16

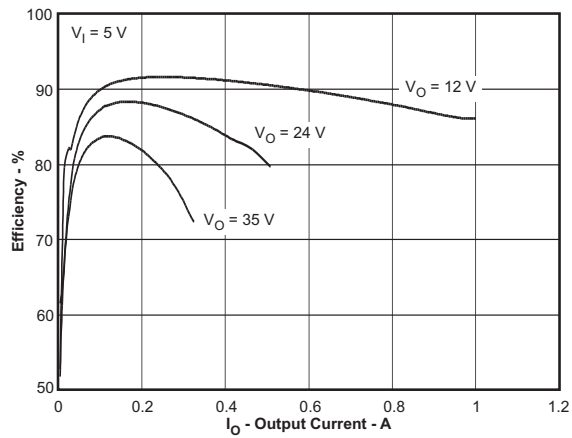

Figure 1. Efficiency vs Output Current

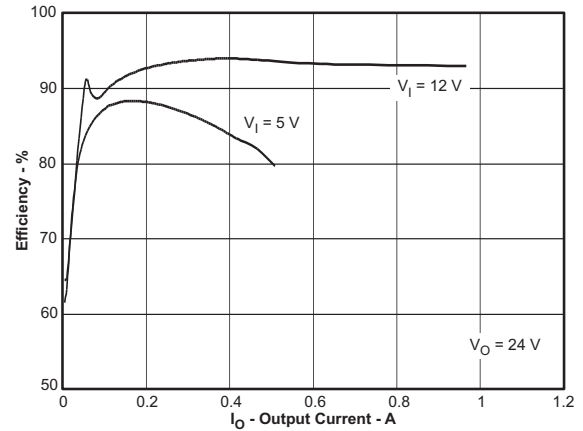

Figure 2. Efficiency vs Output Current

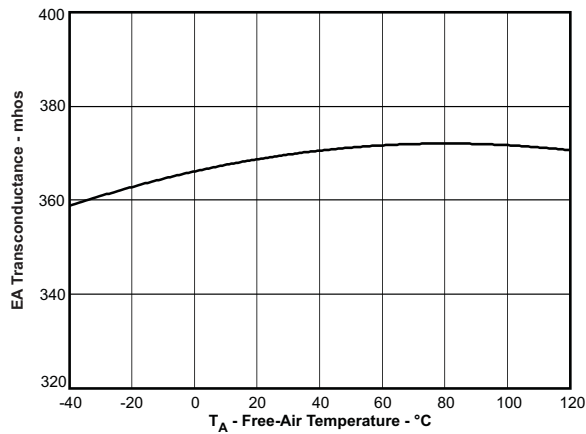

Figure 3. Error Amplifier Transconductance vs Free-Air Temperature

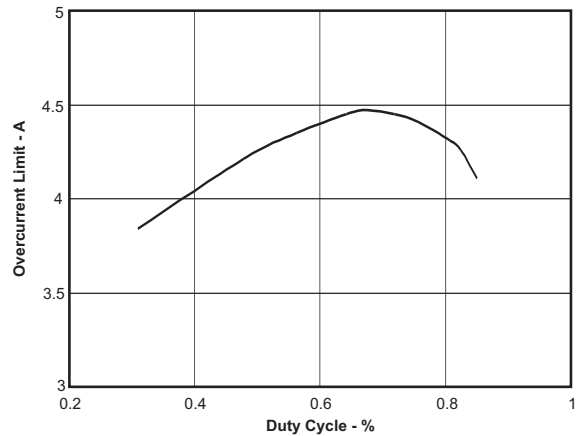

Figure 4. Overcurrent Limit vs Duty Cycle

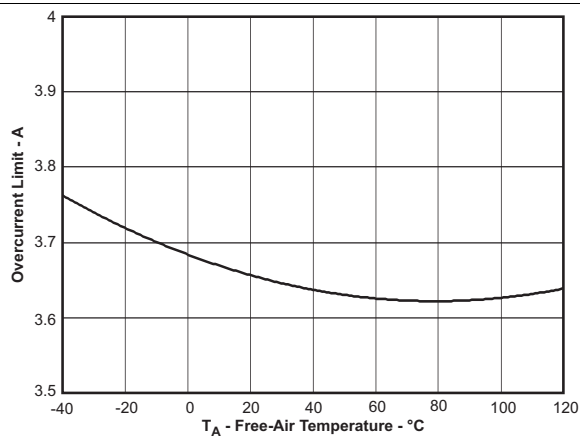

Figure 5. Overcurrent Limit vs Free-Air Temperature

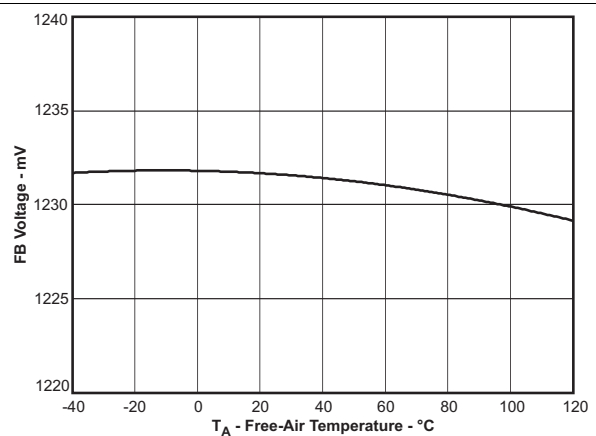

Figure 6. FB Voltage vs Free-Air Temperature

7 Detailed Description

7.1 Overview

The TPS61175 integrates a 40-V low-side switch FET for up to 38-V output. The device regulates the output with current mode pulse width modulation (PWM) control. The PWM control circuitry turns on the switch at the beginning of each switching cycle. The input voltage is applied across the inductor and stores the energy as inductor current ramps up. During this portion of the switching cycle, the load current is provided by the output capacitor. When the inductor current rises to the threshold set by the error amplifier output, the power switch turns off and the external Schottky diode is forward biased. The inductor transfers stored energy to replenish the output capacitor and supply the load current. This operation repeats each every switching cycle. As shown in [Functional Block Diagram](#), the duty cycle of the converter is determined by the PWM control comparator which compares the error amplifier output and the current signal. The switching frequency is programmed by the external resistor or synchronized to an external clock signal.

A ramp signal from the oscillator is added to the current ramp to provide slope compensation. Slope compensation is necessary to avoid subharmonic oscillation that is intrinsic to the current mode control at duty cycle higher than 50%. If the inductor value is lower than 4.7 μH , the slope compensation may not be adequate.

The feedback loop regulates the FB pin to a reference voltage through a transconductance error amplifier. The output of the error amplifier is connected to the COMP pin. An external RC compensation network is connected to the COMP pin to optimize the feedback loop for stability and transient response.

7.2 Functional Block Diagram

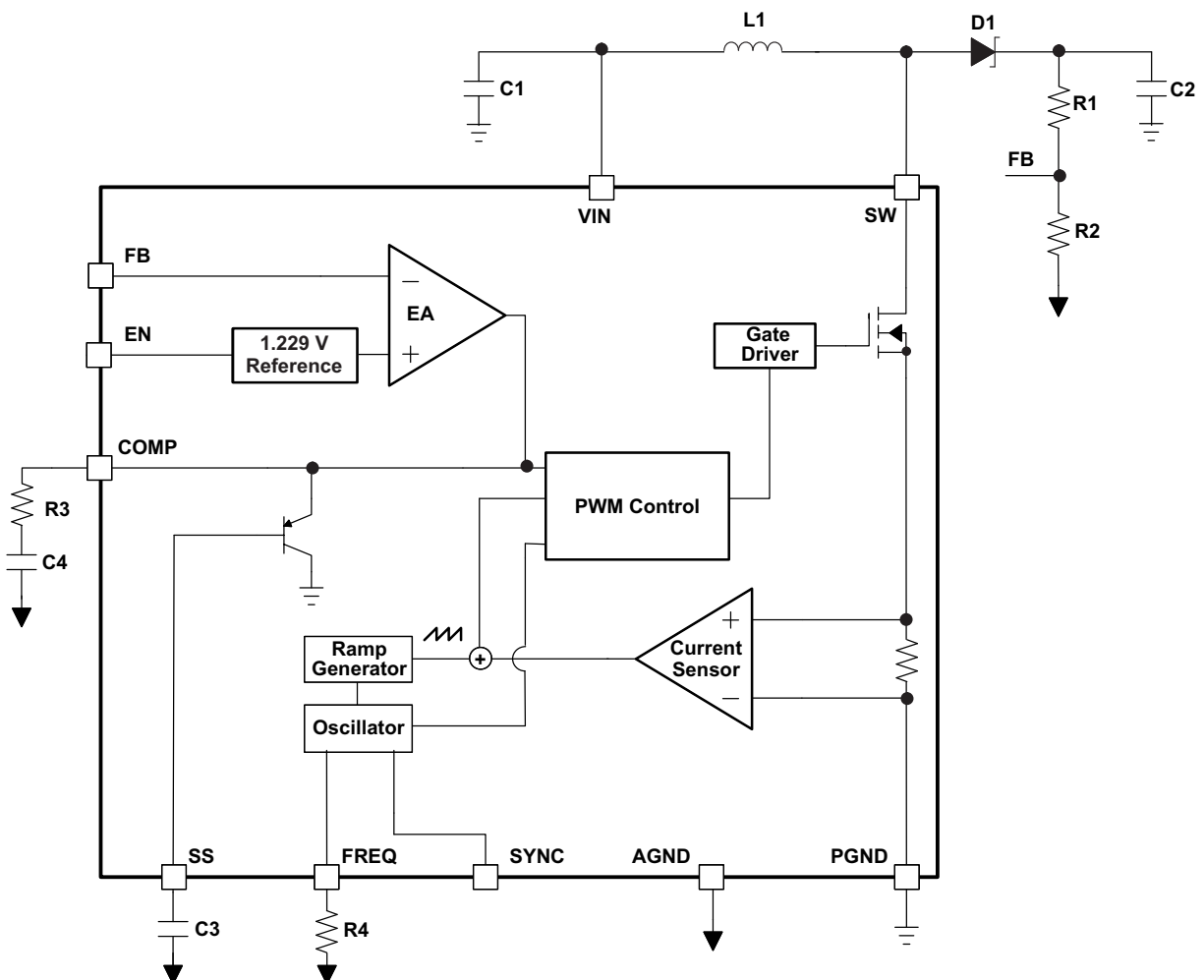

Copyright © 2016, Texas Instruments Incorporated

7.3 Feature Description

7.3.1 Switching Frequency

The switch frequency is set by a resistor (R4) connected to the FREQ pin of the TPS61175. Do not leave this pin open. A resistor must always be connected for proper operation. See [Table 2](#) and [Figure 7](#) for resistor values and corresponding frequencies.

Table 2. Switching Frequency vs External Resistor

R4 (kΩ)	f _{sw} (kHz)
443	240
256	400
176	600
80	1200
51	2000

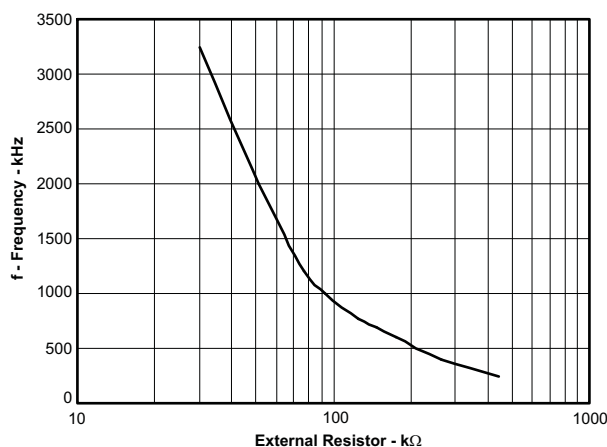

Figure 7. Switching Frequency vs External Resistor

Alternatively, the TPS61175 switching frequency will synchronize to an external clock signal that is applied to the SYNC pin. The logic level of the external clock is shown in the specification table. The duty cycle of the clock is recommended in the range of 10% to 90%. The resistor also must be connected to the FREQ pin when IC is switching by the external clock. The external clock frequency must be within $\pm 20\%$ of the corresponding frequency set by the resistor. For example, if the corresponding frequency as set by a resistor on the FREQ pin is 1.2-MHz, the external clock signal should be in the range of 0.96 MHz to 1.44 MHz.

If the external clock signal is higher than the frequency per the resistor on the FREQ pin, the maximum duty cycle specification (D_{MAX}) should be lowered by 2%. For instance, if the resistor set value is 2.5 MHz, and the external clock is 3 MHz, D_{MAX} is 87% instead of 89%.

7.3.2 Soft Start

The TPS61175 has a built-in soft start circuit which significantly reduces the start-up current spike and output voltage overshoot. When the IC is enabled, an internal bias current (6 μ A typically) charges a capacitor (C3) on the SS pin. The voltage at the capacitor clamps the output of the internal error amplifier that determines the duty cycle of PWM control, thereby the input inrush current is eliminated. Once the capacitor reaches 1.8 V, the soft start cycle is completed and the soft-start voltage no longer clamps the error amplifier output. Refer to [Figure 16](#) for the soft start waveform. See [Table 3](#) for C3 and corresponding soft start time. A 47-nF capacitor eliminates the output overshoot and reduces the peak inductor current for most applications.

Table 3. Soft-Start Time vs C3

V _{IN} (V)	V _{OUT} (V)	LOAD (A)	C _{OUT} (μF)	f _{sw} (MHz)	C3 (nF)	t _{ss} (ms)	OVERSHOT (mV)
5	24	0.4	10	1.2	47	4	none
					10	0.8	210
12	35	0.6	10	2	100	6.5	none
					10	0.4	300

When the EN is pulled low for 10 ms, the IC enters shutdown and the SS capacitor discharges through a 5-kΩ resistor for the next soft start.

7.3.3 Overcurrent Protection

The TPS61175 has a cycle-by-cycle overcurrent limit protection that turns off the power switch once the inductor current reaches the overcurrent limit threshold. The PWM circuitry resets itself at the beginning of the next switch cycle. During an overcurrent event, the output voltage begins to droop as a function of the load on the output. When the FB voltage drops lower than 0.9 V, the switching frequency is automatically reduced to 1/4 of the set value. The switching frequency does not reset until the overcurrent condition is removed. This feature is disabled during soft start.

7.3.4 Enable and Thermal Shutdown

The TPS61175 enters shutdown when the EN voltage is less than 0.4 V for more than 10 ms. In shutdown, the input supply current for the device is less than 1.5 μA (maximum). The EN pin has an internal 800-kΩ pulldown resistor to disable the device when it is floating.

An internal thermal shutdown turns off the device when the typical junction temperature of 160°C is exceeded. The IC restarts when the junction temperature drops by 15°C.

7.3.5 Undervoltage Lockout (UVLO)

An undervoltage lockout circuit prevents mis-operation of the device at input voltages below 2.5-V (typical). When the input voltage is below the undervoltage threshold, the device remains off, and the internal switch FET is turned off. The UVLO threshold is set below minimum operating voltage of 2.9 V to avoid any transient VIN dip triggering the UVLO and causing the device to reset. For the input voltages between UVLO threshold and 2.9 V, the device attempts to operate, but the specifications are not ensured.

7.4 Device Functional Modes

7.4.1 Minimum ON Time and Pulse Skipping

Once the PWM switch is turned on, the TPS61175 has minimum ON pulse width of 60 ns. This sets the limit of the minimum duty cycle of the PWM switch, and it is independent of the set switching frequency. When operating conditions result in the TPS61175 having a minimum ON pulse width less than 60 ns, the IC enters pulse-skipping mode. In this mode, the device keeps the power switch off for several switching cycles to keep the output voltage from rising above the regulated voltage. This operation typically occurs in light load condition when the PWM operates in discontinuous mode. Pulse skipping increases the output voltage ripple, see [Figure 15](#).

When setting switching frequency higher than 1.2 MHz, TI recommends using an external synchronous clock as switching frequency to ensure pulse-skipping function works at light load. When using the internal switching frequency above 1.2 MHz, the pulse-skipping operation may not function. When the pulse-skipping function does not work at light load, the TPS61175 always runs in PWM mode with minimum ON pulse width. To keep the output voltage in regulation, a minimum load is required. The minimum load is related to the input voltage, output voltage, switching frequency, external inductor value and the maximum value of the minimum ON pulse width. Use [Equation 1](#) and [Equation 2](#) to calculate the required minimum load at the worst case. The maximum t_{\min_ON} could be estimated to 80 ns. C_{SW} is the total parasite capacitance at the switching node SW pin. It could be estimated to 100 pF.

$$I_{(\min_load)} = \frac{1}{2} \times \frac{\left(V_{IN} \times t_{\min_ON} + (V_{OUT} + V_D - V_{IN}) \times \sqrt{L \times C_{SW}} \right)^2 \times f_{SW}}{L \times (V_{OUT} + V_D - V_{IN})} \quad \text{When } V_{OUT} + V_D - V_{IN} < V_{IN} \quad (1)$$

$$I_{(\min_load)} = \frac{1}{2} \times \frac{\left(V_{IN} \times t_{\min_ON} + V_{IN} \times \sqrt{L \times C_{SW}} \right)^2 \times f_{SW}}{L \times (V_{OUT} + V_D - V_{IN})} \quad \text{When } V_{OUT} + V_D - V_{IN} > V_{IN} \quad (2)$$

8 Application and Implementation

8.1 Application Information

The following section provides a step-by-step design approach for configuring the TPS61175 as a voltage regulating boost converter, as shown in Figure 8. When configured as SEPIC or flyback converter, a different design approach is required.

8.2 Typical Application

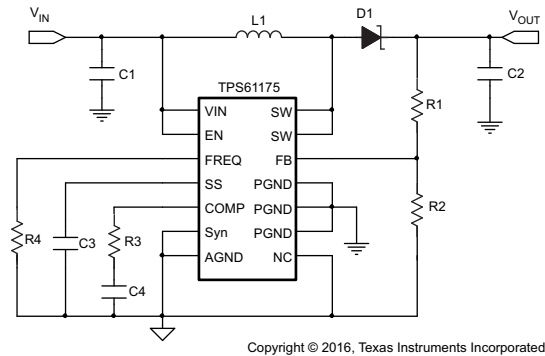

Figure 8. Boost Converter Configuration

8.2.1 Design Requirements

Table 4. Design Parameters

PARAMETERS	VALUES
Input voltage	5 V
Output voltage	24 V
Operating frequency	1.2 MHz

8.2.2 Detailed Design Procedure

8.2.2.1 Custom Design with WEBENCH Tools

Click [here](#) to create a custom design using the TPS61175 device with the WEBENCH® Power Designer.

1. Start by entering your V_{IN} , V_{OUT} and I_{OUT} requirements.
2. Optimize your design for key parameters like efficiency, footprint and cost using the optimizer dial and compare this design with other possible solutions from Texas Instruments.
3. WEBENCH Power Designer provides you with a customized schematic along with a list of materials with real time pricing and component availability.
4. In most cases, you will also be able to:
 - Run electrical simulations to see important waveforms and circuit performance,
 - Run thermal simulations to understand the thermal performance of your board,
 - Export your customized schematic and layout into popular CAD formats,
 - Print PDF reports for the design, and share your design with colleagues.
5. Get more information about WEBENCH tools at www.ti.com/webench.

8.2.2.2 Determining the Duty Cycle

The TPS61175 has a maximum worst case duty cycle of 89% and a minimum on time of 60 ns. These two constraints place limitations on the operating frequency that can be used for a given input to output conversion ratio. The duty cycle at which the converter operates is dependent on the mode in which the converter is running. If the converter is running in discontinuous conduction mode (DCM), where the inductor current ramps to zero at the end of each cycle, the duty cycle varies with changes to the load much more than it does when running in continuous conduction mode (CCM). In continuous conduction mode, where the inductor maintains a dc current, the duty cycle is related primarily to the input and output voltages as computed in [Equation 3](#):

$$D = \frac{V_{OUT} + V_D - V_{IN}}{V_{OUT} + V_D} \quad (3)$$

In discontinuous mode the duty cycle is a function of the load, input and output voltages, inductance and switching frequency as computed in [Equation 4](#):

$$D = \frac{2 \times (V_{OUT} + V_D) \times I_{OUT} \times L \times f_{SW}}{V_{IN}^2} \quad (4)$$

All converters using a diode as the freewheeling or catch component have a load current level at which they transition from discontinuous conduction to continuous conduction. This is the point where the inductor current just falls to zero. At higher load currents, the inductor current does not fall to zero but remains flowing in a positive direction and assumes a trapezoidal wave shape as opposed to a triangular wave shape. This load boundary between discontinuous conduction and continuous conduction can be found for a set of converter parameters in [Equation 5](#):

$$I_{OUT(crit)} = \frac{(V_{OUT} + V_D - V_{IN}) \times V_{IN}^2}{2 \times (V_{OUT} + V_D)^2 \times f_{SW} \times L} \quad (5)$$

For loads higher than the result of [Equation 5](#), the duty cycle is given by [Equation 3](#) and for loads less than the results of [Equation 4](#), the duty cycle is given [Equation 5](#). For [Equation 3](#) through [Equation 5](#), the variable definitions are as follows:

- V_{OUT} is the output voltage of the converter in V
- V_D is the forward conduction voltage drop across the rectifier or catch diode in V
- V_{IN} is the input voltage to the converter in V
- I_{OUT} is the output current of the converter in A
- L is the inductor value in H
- f_{SW} is the switching frequency in Hz

Unless otherwise stated, the design equations that follow assume that the converter is running in continuous mode.

8.2.2.3 Selecting the Inductor

The selection of the inductor affects steady state operation as well as transient behavior and loop stability. These factors make it the most important component in power regulator design. There are three important inductor specifications, inductor value, DC resistance and saturation current. Considering inductor value alone is not enough.

Inductor values can have $\pm 20\%$ tolerance with no current bias. When the inductor current approaches saturation level, its inductance can fall to some percentage of its 0-A value depending on how the inductor vendor defines saturation current. For CCM operation, the rule of thumb is to choose the inductor so that its inductor ripple current (ΔI_L) is no more than a certain percentage (RPL% = 20–40%) of its average DC value ($I_{IN(AVG)} = I_{L(AVG)}$).

$$\begin{aligned} \Delta I_L &= \frac{V_{IN} \times D}{L \times f_{SW}} = \frac{(V_{OUT} + V_D - V_{IN}) \times (1 - D)}{L \times f_{SW}} = \frac{1}{L \times f_{SW} \times \left(\frac{1}{V_{OUT} + V_D - V_{IN}} + \frac{1}{V_{IN}} \right)} \\ &\leq \text{RPL}\% \times \frac{P_{OUT}}{V_{IN} \times \eta_{est}} \end{aligned} \quad (6)$$

Rearranging and solving for L gives:

$$L \geq \frac{\eta_{est} \times V_{IN}}{\left[f_{SW} \left(\frac{1}{V_{OUT} + V_D - V_{IN}} + \frac{1}{V_{IN}} \right) \right]} \times RPL\% P_{OUT} \quad (7)$$

Choosing the inductor ripple current to closer to 20% of the average inductor current results in a larger inductance value, maximizes the converter's potential output current and minimizes EMI. Choosing the inductor ripple current closer to 40% of $I_{L(AVG)}$ results in a smaller inductance value, and a physically smaller inductor, improves transient response but results in potentially higher EMI and lower efficiency if the DCR of the smaller packaged inductor is significantly higher. Using an inductor with a smaller inductance value than computed above may result in the converter operating in DCM. This reduces the maximum output current of the boost converter, causes larger input voltage and output ripple, and typically reduces efficiency. [Table 5](#) lists the recommended inductor for the TPS61175.

Table 5. Recommended Inductors for TPS61175

PART NUMBER	L (μ H)	DCR MAX (m Ω)	SATURATION CURRENT (A)	SIZE (L x W x H mm)	VENDOR
D104C2	10	44	3.6	10.4 x 10.4 x 4.8	TOKO
VLF10040	15	42	3.1	10 x 9.7 x 4	TDK
CDRH105RNP	22	61	2.9	10.5 x 10.3 x 5.1	Sumida
MSS1038	15	50	3.8	10 x 10.2 x 3.8	Coilcraft

The device has built-in slope compensation to avoid subharmonic oscillation associated with current mode control. If the inductor value is lower than 4.7 μ H, the slope compensation may not be adequate, and the loop can be unstable. Applications requiring inductors above 47 μ H have not been evaluated. Therefore, the user is responsible for verifying operation if they select an inductor that is outside the 4.7- μ H to 47- μ H recommended range.

8.2.2.4 Computing the Maximum Output Current

The over-current limit for the integrated power FET limits the maximum input current and thus the maximum input power for a given input voltage. Maximum output power is less than maximum input power due to power conversion losses. Therefore, the current limit setting, input voltage, output voltage and efficiency can all change the maximum current output ($I_{OUT(MAX)}$). The current limit clamps the peak inductor current, therefore the ripple has to be subtracted to derive maximum DC current.

$$I_{OUT(max)} = \frac{V_{IN(max)} \times I_{IN(max)} \times \eta_{est}}{V_{OUT}} = \frac{V_{IN(max)} \times I_{LIM} \times (1 - \%RPL/2) \times \eta_{est}}{V_{OUT}}$$

where

- I_{LIM} = overcurrent limit
 - η_{est} = efficiency estimate based on similar applications or computed above
- (8)

For instance, when $V_{IN} = 12$ V is boosted to $V_{OUT} = 24$ V, the inductor is 10 μ H, the Schottky forward voltage is 0.4 V, and the switching frequency is 1.2 MHz; then the maximum output current is 1.2 A in typical condition, assuming 90% efficiency and a %RPL = 20%.

8.2.2.5 Setting Output Voltage

To set the output voltage in either DCM or CCM, select the values of R1 and R2 according to [Equation 9](#):

$$V_{out} = 1.229 \text{ V} \times \left(\frac{R1}{R2} + 1 \right)$$

$$R1 = R2 \times \left(\frac{V_{out}}{1.229\text{V}} - 1 \right) \quad (9)$$

Considering the leakage current through the resistor divider and noise decoupling into FB pin, an optimum value for R2 is around 10 k. The output voltage tolerance depends on the V_{FB} accuracy and the tolerance of R1 and R2.

8.2.2.6 Setting the Switching Frequency

Choose the appropriate resistor from the resistance versus frequency table [Table 2](#) or graph [Figure 7](#). A resistor must be placed from the FREQ pin to ground, even if an external oscillation is applied for synchronization.

Increasing switching frequency reduces the value of external capacitors and inductors, but also reduces the power conversion efficiency. The user should set the frequency for the minimum tolerable efficiency.

8.2.2.7 Setting the Soft-Start Time

Choose the appropriate capacitor from the soft-start table, [Table 3](#). Increasing the soft-start time reduces the overshoot during start-up.

8.2.2.8 Selecting the Schottky Diode

The high switching frequency of the TPS61175 demands a high-speed rectification for optimum efficiency. Ensure that the diode's average and peak current rating exceed the average output current and peak inductor current. In addition, the diode's reverse breakdown voltage must exceed the switch FET rating voltage of 40 V. So, the VISHAY SS3P6L-E3/86A is recommended for TPS61175. The power dissipation of the diode's package must be larger than $I_{OUT(max)} \times V_D$.

8.2.2.9 Selecting the Input and Output Capacitors

The output capacitor is mainly selected to meet the requirements for the output ripple and load transient. Then the loop is compensated for the output capacitor selected. The output ripple voltage is related to the capacitor's capacitance and its equivalent series resistance (ESR). Assuming a capacitor with zero ESR, the minimum capacitance needed for a given ripple can be calculated using [Equation 10](#):

$$C_{out} = \frac{(V_{OUT} - V_{IN})I_{out}}{V_{OUT} \times F_s \times V_{ripple}} \quad (10)$$

where V_{ripple} = peak to peak output ripple. The additional output ripple component caused by ESR is calculated using:

$$V_{ripple_ESR} = I \times R_{ESR}$$

Due to its low ESR, V_{ripple_ESR} can be neglected for ceramic capacitors, but must be considered if tantalum or electrolytic capacitors are used.

The minimum ceramic output capacitance needed to meet a load transient requirement can be estimated using [Equation 11](#):

$$C_{OUT} = \frac{\Delta I_{TRAN}}{2 \times \pi \times f_{LOOP-BW} \times \Delta V_{TRAN}}$$

where

- ΔI_{TRAN} is the transient load current step
- ΔV_{TRAN} is the allowed voltage dip for the load current step
- $f_{LOOP-BW}$ is the control loop bandwidth (that is, the frequency where the control loop gain crosses zero). (11)

Care must be taken when evaluating a ceramic capacitor's derating under DC bias, aging and AC signal. For example, larger form factor capacitors (in 1206 size) have their self resonant frequencies in the range of the switching frequency. So the effective capacitance is significantly lower. The DC bias can also significantly reduce capacitance. Ceramic capacitors can lose as much as 50% of its capacitance at its rated voltage. Therefore, one must add margin on the voltage rating to ensure adequate capacitance at the required output voltage.

For a typical boost converter implementation, at least 4.7 μ F of ceramic input and output capacitance is recommended. Additional input and output capacitance may be required to meet ripple and/or transient requirements.

The popular vendors for high value ceramic capacitors are:

TDK (<http://www.component.tdk.com/components.php>)

Murata (<http://www.murata.com/cap/index.html>)

8.2.2.10 Compensating the Small Signal Control Loop

All continuous mode boost converters have a right half plane zero (f_{RHPZ}) due to the inductor being removed from the output during charging. In a traditional voltage mode controlled boost converter, the inductor and output capacitor form a small signal double pole. For a negative feedback system to be stable, the feedback signal must have a gain less than 1 before having 180 degrees of phase shift. With its double pole and RHPZ all providing phase shift, voltage mode boost converters are a challenge to compensate. In a converter with current mode control, there are essentially two loops, an inner current feedback loop created by the inductor current information sensed across R_{SENSE} (40mΩ) and the output voltage feedback loop. The inner current loop allows the switch, inductor and modulator to be lumped together into a small signal variable current source controlled by the error amplifier, as shown in Figure 9.

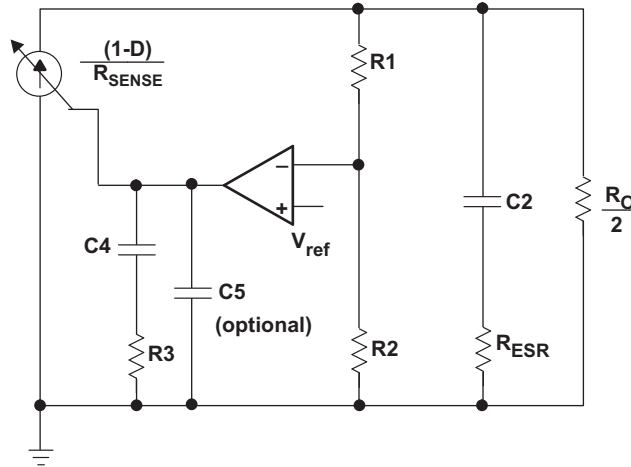

Figure 9. Small Signal Model of a Current Mode Boost in CCM

The new power stage, including the slope compensation, small signal model becomes:

$$G_{PS}(s) = \frac{R_{OUT} \times (1-D)}{2 \times R_{SENSE}} \times \frac{\left(1 + \frac{s}{2 \times \pi \times f_{ESR}}\right) \left(1 - \frac{s}{2 \times \pi \times f_{RHPZ}}\right)}{1 + \frac{s}{2 \times \pi \times f_P}} \times He(s) \quad (12)$$

Where

$$f_P = \frac{2}{2 \pi \times R_O \times C_2} \quad (13)$$

$$f_{ESR} \approx \frac{1}{2 \pi \times R_{ESR} \times C_2} \quad (14)$$

$$f_{RHPZ} = \frac{R_O}{2 \pi \times L} \times \left(\frac{V_{IN}}{V_{OUT}}\right)^2 \quad (15)$$

And

$$He(s) = \frac{1}{1 + \frac{s \times \left[\left(1 + \frac{S_e}{S_n}\right) \times (1-D) - 0.5\right]}{f_{SW}} + \frac{s^2}{(\pi \times f_{SW})^2}} \quad (16)$$

$He(s)$ models the inductor current sampling effect as well as the slope compensation effect on the small signal response. Note that if $S_n > S_e$, for example, when L is smaller than recommended, the converter operates as a voltage mode converter and the above model no longer holds.

The slope compensation in TPS61175 is shown as follows:

$$S_n = \frac{V_{OUT} + V_D - V_{IN}}{L} \times R_{SENSE} \quad (17)$$

$$S_e = \frac{0.32 \text{ V} / R_4}{16 \times (1-D) \times 6 \text{ pF}} + \frac{0.5 \text{ } \mu\text{A}}{6 \text{ pF}}$$

Where R4 is the frequency setting resistor

(18)

Figure 10 shows a Bode plot of a typical CCM boost converter power stage.

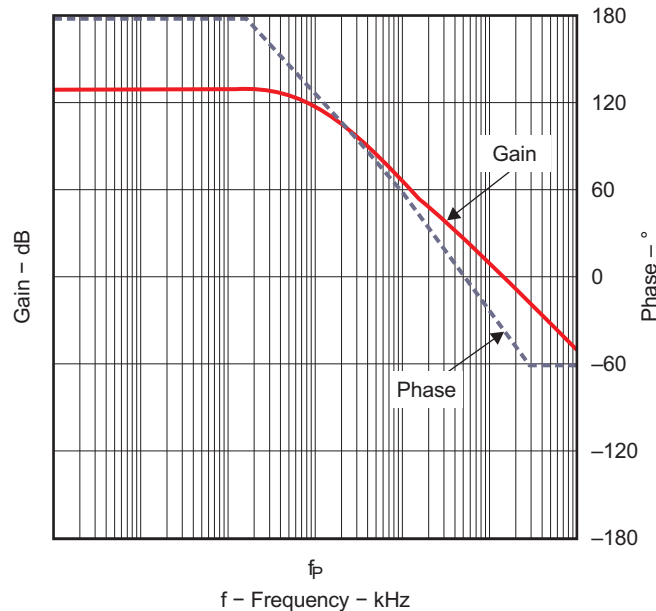

Figure 10. Bode Plot of Power Stage Gain and Phase

The TPS61175 COMP pin is the output of the internal trans-conductance amplifier. Equation 19 shows the equation for feedback resistor network and the error amplifier.

$$H_{EA} = G_{EA} \times R_{EA} \times \frac{R_2}{R_2 + R_1} \times \frac{1 + \frac{s}{2 \times \pi \times f_Z}}{\left(1 + \frac{s}{2 \times \pi \times f_{P1}}\right) \times \left(1 + \frac{s}{2 \times \pi \times f_{P2}}\right)}$$

where

- G_{EA} and R_{EA} are the amplifier's trans-conductance and output resistance located in the [Electrical Characteristics](#) table. (19)

$$f_{P1} = \frac{1}{2 \pi \times R_{EA} \times C_4} \quad (20)$$

$$f_{P2} = \frac{1}{2 \pi \times R_3 \times C_5} \text{ (optional)}$$

C5 is optional and can be modeled as 10 pF stray capacitance.

(21)

and

$$f_Z = \frac{1}{2 \pi \times R_3 \times C_4} \quad (22)$$

Figure 11 shows a typical bode plot for transfer function H(s).

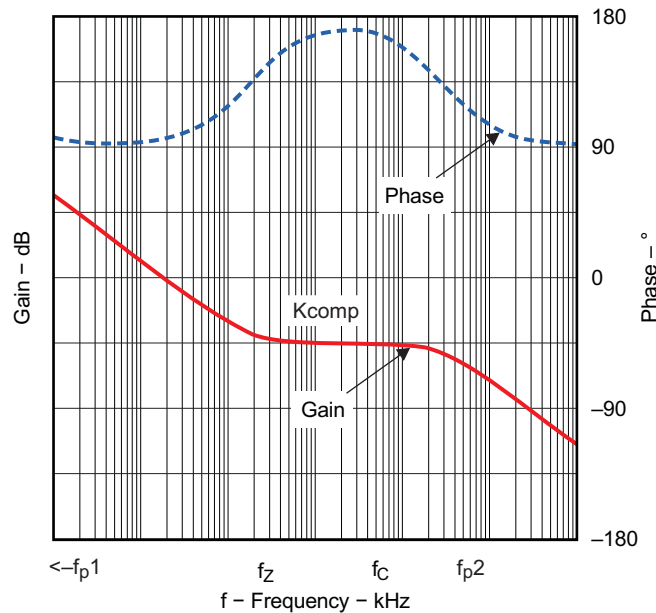

Figure 11. Bode Plot of Feedback Resistors and Compensated Amplifier Gain and Phase

The next step is to choose the loop crossover frequency, f_c . The higher in frequency that the loop gain stays above zero before crossing over, the faster the loop response will be and therefore the lower the output voltage will droop during a step load. It is generally accepted that the loop gain cross over no higher than the lower of either 1/5 of the switching frequency, f_{SW} , or 1/3 of the RHPZ frequency, f_{RHPZ} . To approximate a single pole roll-off up to f_{p2} , select R3 so that the compensation gain, K_{COMP} , at f_c on [Figure 11](#) is the reciprocal of the gain, K_{PW} , read at frequency f_c from the [Figure 10](#) bode plot, or more simply:

$$K_{COMP}(f_c) = 20 \times \log(G_{EA} \times R3 \times R2 / (R2 + R1)) = 1 / K_{PW}(f_c)$$

This makes the total loop gain, $T(s) = G_{PS}(s) \times H_{EA}(s)$, zero at the f_c . Then, select C4 so that $f_z \cong f_c / 10$ and optional $f_{p2} > f_c \times 10$. Following this method should lead to a loop with a phase margin near 45 degrees. Lowering R3 while keeping $f_z \cong f_c / 10$ increases the phase margin and therefore increases the time it takes for the output voltage to settle following a step load.

In the TPS61175, if the FB pin voltage changes suddenly due to a load step on the output voltage, the error amplifier increases its transconductance for 8-ms in an effort to speed up the IC's transient response and reduce output voltage droop due to the load step. For example, if the FB voltage decreases 10 mV due to load change, the error amplifier increases its source current through COMP by 5 times; if FB voltage increases 11 mV, the sink current through COMP is increased to 3.5 times normal value. This feature often results in saw tooth ringing on the output voltage, shown as [Figure 13](#). Designing the loop for greater than 45 degrees of phase margin and greater than 10-dB gain margin minimizes the amplitude of this ringing. This feature is disabled during soft start.

8.2.3 Application Curves

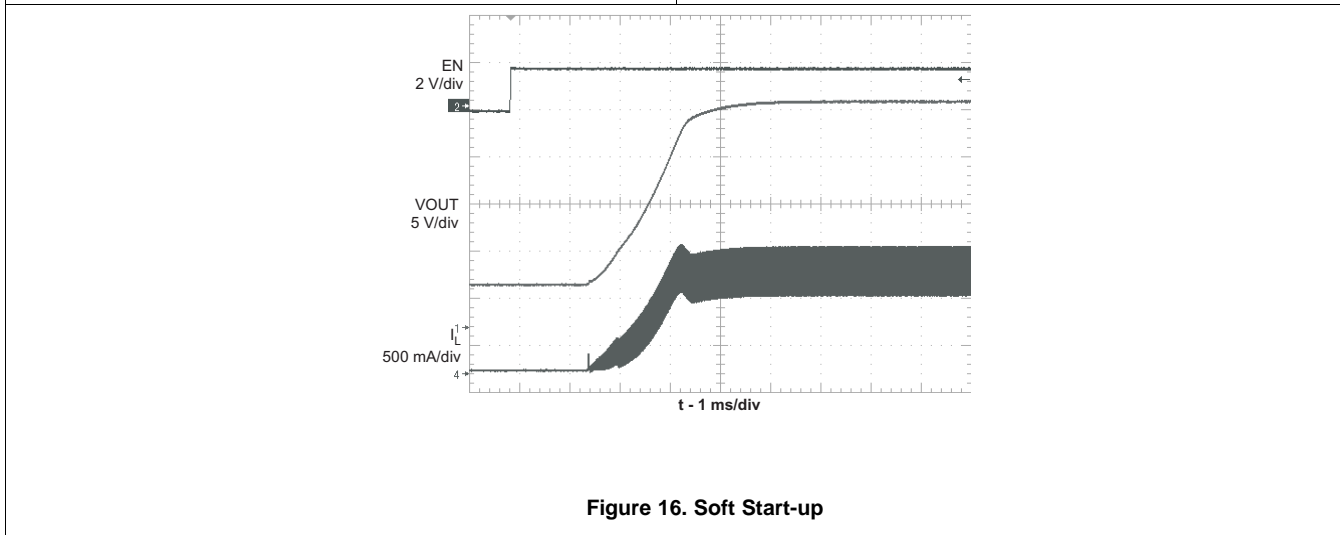
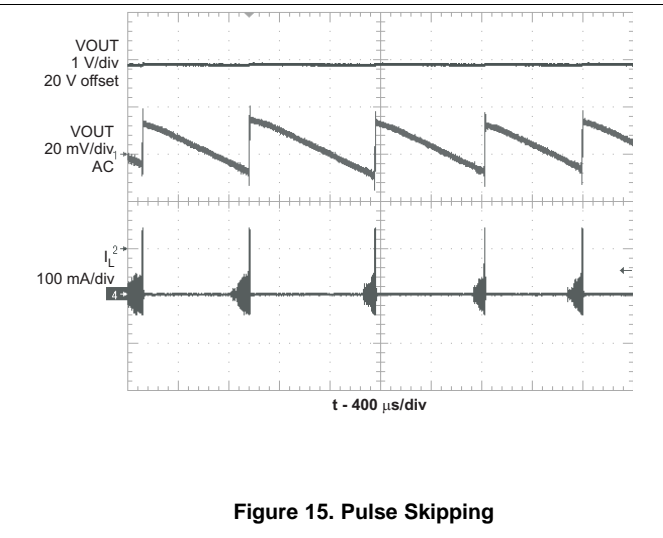
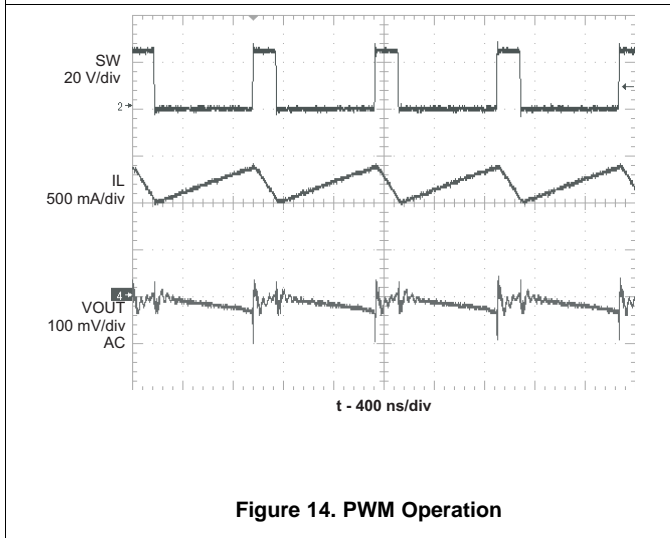
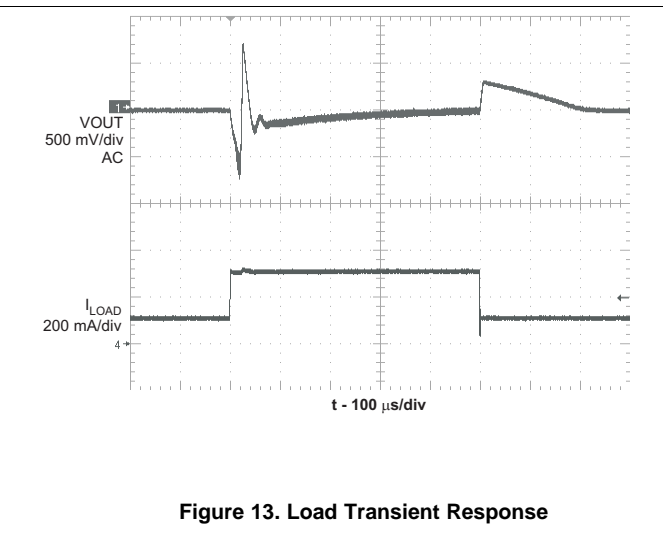
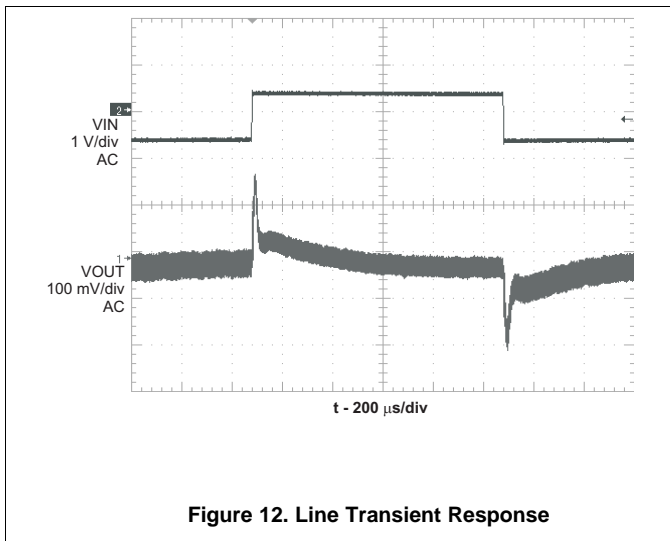

9 Power Supply Recommendations

The device is designed to operate from an input voltage supply range between 2.9 V and 18 V. The input power supply's output current must be rated according to the supply voltage, output voltage and output current of the TPS61175.

10 Layout

10.1 Layout Guidelines

- As for all switching power supplies, especially those running at high switching frequency and high currents, layout is an important design step. If layout is not carefully done, the regulator could suffer from instability as well as noise problems. To maximize efficiency, switch rise and fall times are very fast. To prevent radiation of high frequency noise (for example, EMI), proper layout of the high frequency switching path is essential.
- Minimize the length and area of all traces connected to the SW pin and always use a ground plane under the switching regulator to minimize interplane coupling.
- The high current path including the switch, Schottky diode, and output capacitor, contains nanosecond rise and fall times and must be kept as short as possible.
- The input capacitor must not only be close to the VIN pin, but also to the GND pin in order to reduce the input supply ripple.

10.2 Layout Example

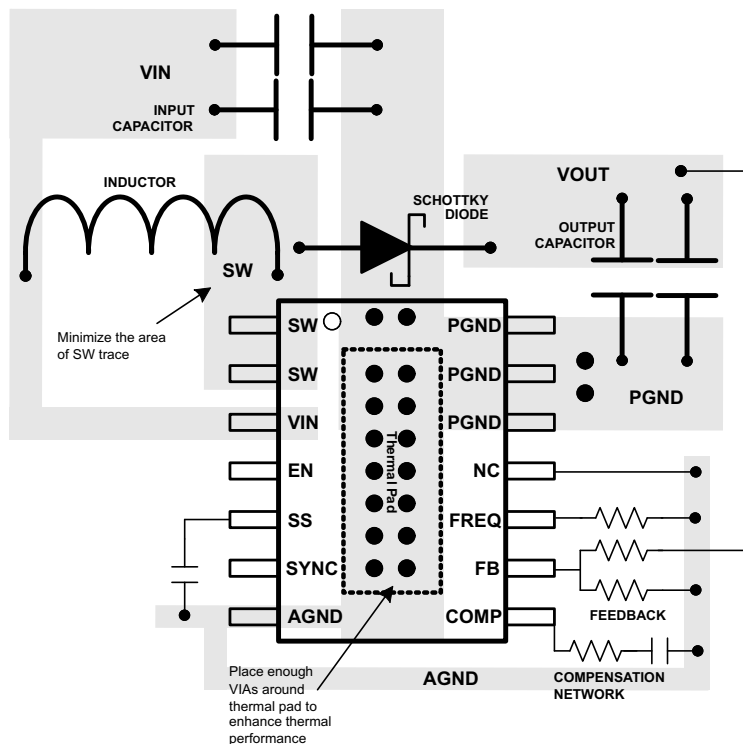

Figure 17. TPS61175 Layout

10.3 Thermal Considerations

Restrict the maximum IC junction temperature to 125°C under normal operating conditions. This restriction limits the power dissipation of the TPS61175. Calculate the maximum allowable dissipation, $P_{D(\text{maximum})}$, and keep the actual dissipation less than or equal to $P_{D(\text{maximum})}$. The maximum-power-dissipation limit is determined using [Equation 23](#):

$$P_{D(\text{max})} = \frac{125^{\circ}\text{C} - T_A}{R_{\theta JA}}$$

where

- T_A is the maximum ambient temperature for the application
- $R_{\theta JA}$ is the thermal resistance junction-to-ambient given in [Thermal Information](#). (23)

The TPS61175 comes in a thermally enhanced TSSOP package. This package includes a thermal pad that improves the thermal capabilities of the package. The $R_{\theta JA}$ of the TSSOP package greatly depends on the PCB layout and thermal pad connection. The thermal pad must be soldered to the analog ground on the PCB. Using thermal vias underneath the thermal pad.

11 Device and Documentation Support

11.1 Device Support

11.1.1 Third-Party Products Disclaimer

TI'S PUBLICATION OF INFORMATION REGARDING THIRD-PARTY PRODUCTS OR SERVICES DOES NOT CONSTITUTE AN ENDORSEMENT REGARDING THE SUITABILITY OF SUCH PRODUCTS OR SERVICES OR A WARRANTY, REPRESENTATION OR ENDORSEMENT OF SUCH PRODUCTS OR SERVICES, EITHER ALONE OR IN COMBINATION WITH ANY TI PRODUCT OR SERVICE.

11.2 Development Support

11.2.1 Custom Design with WEBENCH Tools

[Click here](#) to create a custom design using the TPS61175 device with the WEBENCH® Power Designer.

1. Start by entering your V_{IN} , V_{OUT} and I_{OUT} requirements.
2. Optimize your design for key parameters like efficiency, footprint and cost using the optimizer dial and compare this design with other possible solutions from Texas Instruments.
3. WEBENCH Power Designer provides you with a customized schematic along with a list of materials with real time pricing and component availability.
4. In most cases, you will also be able to:
 - Run electrical simulations to see important waveforms and circuit performance,
 - Run thermal simulations to understand the thermal performance of your board,
 - Export your customized schematic and layout into popular CAD formats,
 - Print PDF reports for the design, and share your design with colleagues.
5. Get more information about WEBENCH tools at www.ti.com/webench.

11.3 Receiving Notification of Documentation Updates

To receive notification of documentation updates, navigate to the device product folder on ti.com. In the upper right corner, click on *Alert me* to register and receive a weekly digest of any product information that has changed. For change details, review the revision history included in any revised document.

11.4 Community Resources

The following links connect to TI community resources. Linked contents are provided "AS IS" by the respective contributors. They do not constitute TI specifications and do not necessarily reflect TI's views; see TI's [Terms of Use](#).

TI E2E™ Online Community *TI's Engineer-to-Engineer (E2E) Community*. Created to foster collaboration among engineers. At e2e.ti.com, you can ask questions, share knowledge, explore ideas and help solve problems with fellow engineers.

Design Support *TI's Design Support* Quickly find helpful E2E forums along with design support tools and contact information for technical support.

11.5 Trademarks

PowerPad, E2E are trademarks of Texas Instruments.
WEBENCH is a registered trademark of Texas Instruments.
All other trademarks are the property of their respective owners.

11.6 Electrostatic Discharge Caution



These devices have limited built-in ESD protection. The leads should be shorted together or the device placed in conductive foam during storage or handling to prevent electrostatic damage to the MOS gates.

11.7 Glossary

[SLYZ022](#) — *TI Glossary*.

This glossary lists and explains terms, acronyms, and definitions.

12 Mechanical, Packaging, and Orderable Information

The following pages include mechanical, packaging, and orderable information. This information is the most current data available for the designated devices. This data is subject to change without notice and revision of this document. For browser-based versions of this data sheet, refer to the left-hand navigation.

PACKAGING INFORMATION

Orderable Device	Status (1)	Package Type	Package Drawing	Pins	Package Qty	Eco Plan (2)	Lead/Ball Finish (6)	MSL Peak Temp (3)	Op Temp (°C)	Device Marking (4/5)	Samples
TPS61175PWP	ACTIVE	HTSSOP	PWP	14	90	Green (RoHS & no Sb/Br)	NIPDAU	Level-2-260C-1 YEAR	-40 to 85	61175	Samples
TPS61175PWPR	ACTIVE	HTSSOP	PWP	14	2000	Green (RoHS & no Sb/Br)	NIPDAU	Level-2-260C-1 YEAR	-40 to 85	61175	Samples

(1) The marketing status values are defined as follows:

ACTIVE: Product device recommended for new designs.

LIFEBUY: TI has announced that the device will be discontinued, and a lifetime-buy period is in effect.

NRND: Not recommended for new designs. Device is in production to support existing customers, but TI does not recommend using this part in a new design.

PREVIEW: Device has been announced but is not in production. Samples may or may not be available.

OBsolete: TI has discontinued the production of the device.

(2) **RoHS:** TI defines "RoHS" to mean semiconductor products that are compliant with the current EU RoHS requirements for all 10 RoHS substances, including the requirement that RoHS substance do not exceed 0.1% by weight in homogeneous materials. Where designed to be soldered at high temperatures, "RoHS" products are suitable for use in specified lead-free processes. TI may reference these types of products as "Pb-Free".

RoHS Exempt: TI defines "RoHS Exempt" to mean products that contain lead but are compliant with EU RoHS pursuant to a specific EU RoHS exemption.

Green: TI defines "Green" to mean the content of Chlorine (Cl) and Bromine (Br) based flame retardants meet JS709B low halogen requirements of <=1000ppm threshold. Antimony trioxide based flame retardants must also meet the <=1000ppm threshold requirement.

(3) MSL, Peak Temp. - The Moisture Sensitivity Level rating according to the JEDEC industry standard classifications, and peak solder temperature.

(4) There may be additional marking, which relates to the logo, the lot trace code information, or the environmental category on the device.

(5) Multiple Device Markings will be inside parentheses. Only one Device Marking contained in parentheses and separated by a "~" will appear on a device. If a line is indented then it is a continuation of the previous line and the two combined represent the entire Device Marking for that device.

(6) Lead/Ball Finish - Orderable Devices may have multiple material finish options. Finish options are separated by a vertical ruled line. Lead/Ball Finish values may wrap to two lines if the finish value exceeds the maximum column width.

Important Information and Disclaimer:The information provided on this page represents TI's knowledge and belief as of the date that it is provided. TI bases its knowledge and belief on information provided by third parties, and makes no representation or warranty as to the accuracy of such information. Efforts are underway to better integrate information from third parties. TI has taken and continues to take reasonable steps to provide representative and accurate information but may not have conducted destructive testing or chemical analysis on incoming materials and chemicals. TI and TI suppliers consider certain information to be proprietary, and thus CAS numbers and other limited information may not be available for release.

In no event shall TI's liability arising out of such information exceed the total purchase price of the TI part(s) at issue in this document sold by TI to Customer on an annual basis.

OTHER QUALIFIED VERSIONS OF TPS61175 :

- Automotive: [TPS61175-Q1](#)

NOTE: Qualified Version Definitions:

- Automotive - Q100 devices qualified for high-reliability automotive applications targeting zero defects

TAPE AND REEL INFORMATION



QUADRANT ASSIGNMENTS FOR PIN 1 ORIENTATION IN TAPE



*All dimensions are nominal

Device	Package Type	Package Drawing	Pins	SPQ	Reel Diameter (mm)	Reel Width W1 (mm)	A0 (mm)	B0 (mm)	K0 (mm)	P1 (mm)	W (mm)	Pin1 Quadrant
TPS61175PWPR	HTSSOP	PWP	14	2000	330.0	12.4	6.9	5.6	1.6	8.0	12.0	Q1

TAPE AND REEL BOX DIMENSIONS



*All dimensions are nominal

Device	Package Type	Package Drawing	Pins	SPQ	Length (mm)	Width (mm)	Height (mm)
TPS61175PWPR	HTSSOP	PWP	14	2000	350.0	350.0	43.0

PWP (R-PDSO-G14)

PowerPAD™ PLASTIC SMALL OUTLINE



- NOTES:
- All linear dimensions are in millimeters.
 - This drawing is subject to change without notice.
 - Body dimensions do not include mold flash or protrusions. Mold flash and protrusion shall not exceed 0.15 per side.
 - This package is designed to be soldered to a thermal pad on the board. Refer to Technical Brief, PowerPad Thermally Enhanced Package, Texas Instruments Literature No. SLMA002 for information regarding recommended board layout. This document is available at www.ti.com <<http://www.ti.com>>.
 - See the additional figure in the Product Data Sheet for details regarding the exposed thermal pad features and dimensions.
 - Falls within JEDEC MO-153

PowerPAD is a trademark of Texas Instruments.

THERMAL PAD MECHANICAL DATA

PWP (R-PDSO-G14)

PowerPAD™ SMALL PLASTIC OUTLINE

THERMAL INFORMATION

This PowerPAD™ package incorporates an exposed thermal pad that is designed to be attached to a printed circuit board (PCB). The thermal pad must be soldered directly to the PCB. After soldering, the PCB can be used as a heatsink. In addition, through the use of thermal vias, the thermal pad can be attached directly to the appropriate copper plane shown in the electrical schematic for the device, or alternatively, can be attached to a special heatsink structure designed into the PCB. This design optimizes the heat transfer from the integrated circuit (IC).

For additional information on the PowerPAD package and how to take advantage of its heat dissipating abilities, refer to Technical Brief, PowerPAD Thermally Enhanced Package, Texas Instruments Literature No. SLMA002 and Application Brief, PowerPAD Made Easy, Texas Instruments Literature No. SLMA004. Both documents are available at www.ti.com.

The exposed thermal pad dimensions for this package are shown in the following illustration.

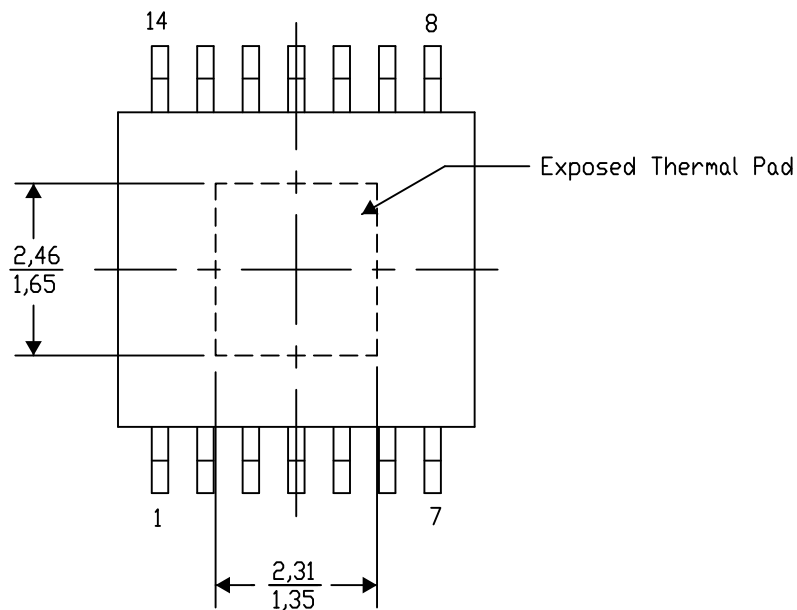

Top View

Exposed Thermal Pad Dimensions

4206332-2/AO 01/16

NOTE: A. All linear dimensions are in millimeters

PowerPAD is a trademark of Texas Instruments

PWP (R-PDSO-G14)

PowerPAD™ PLASTIC SMALL OUTLINE

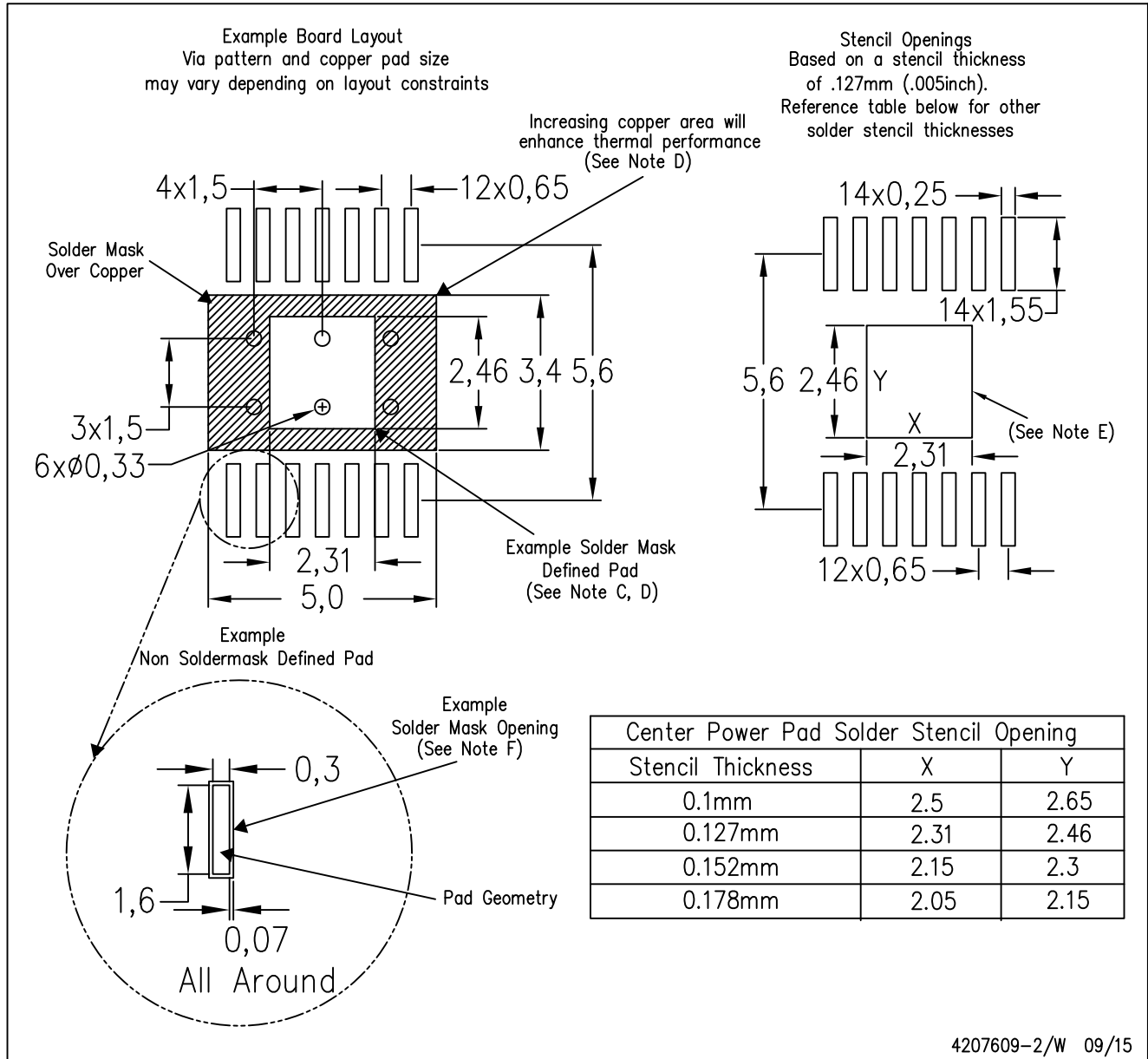

- NOTES:
- A. All linear dimensions are in millimeters.
 - B. This drawing is subject to change without notice.
 - C. Customers should place a note on the circuit board fabrication drawing not to alter the center solder mask defined pad.
 - D. This package is designed to be soldered to a thermal pad on the board. Refer to Technical Brief, PowerPAD Thermally Enhanced Package, Texas Instruments Literature No. SLMA002, SLMA004, and also the Product Data Sheets for specific thermal information, via requirements, and recommended board layout. These documents are available at www.ti.com <<http://www.ti.com>>. Publication IPC-7351 is recommended for alternate designs.
 - E. Laser cutting apertures with trapezoidal walls and also rounding corners will offer better paste release. Customers should contact their board assembly site for stencil design recommendations. Example stencil design based on a 50% volumetric metal load solder paste. Refer to IPC-7525 for other stencil recommendations.
 - F. Customers should contact their board fabrication site for solder mask tolerances between and around signal pads.

THERMAL PAD MECHANICAL DATA

PWP (R-PDSO-G14)

PowerPAD™ SMALL PLASTIC OUTLINE

THERMAL INFORMATION

This PowerPAD™ package incorporates an exposed thermal pad that is designed to be attached to a printed circuit board (PCB). The thermal pad must be soldered directly to the PCB. After soldering, the PCB can be used as a heatsink. In addition, through the use of thermal vias, the thermal pad can be attached directly to the appropriate copper plane shown in the electrical schematic for the device, or alternatively, can be attached to a special heatsink structure designed into the PCB. This design optimizes the heat transfer from the integrated circuit (IC).

For additional information on the PowerPAD package and how to take advantage of its heat dissipating abilities, refer to Technical Brief, PowerPAD Thermally Enhanced Package, Texas Instruments Literature No. SLMA002 and Application Brief, PowerPAD Made Easy, Texas Instruments Literature No. SLMA004. Both documents are available at www.ti.com.

The exposed thermal pad dimensions for this package are shown in the following illustration.

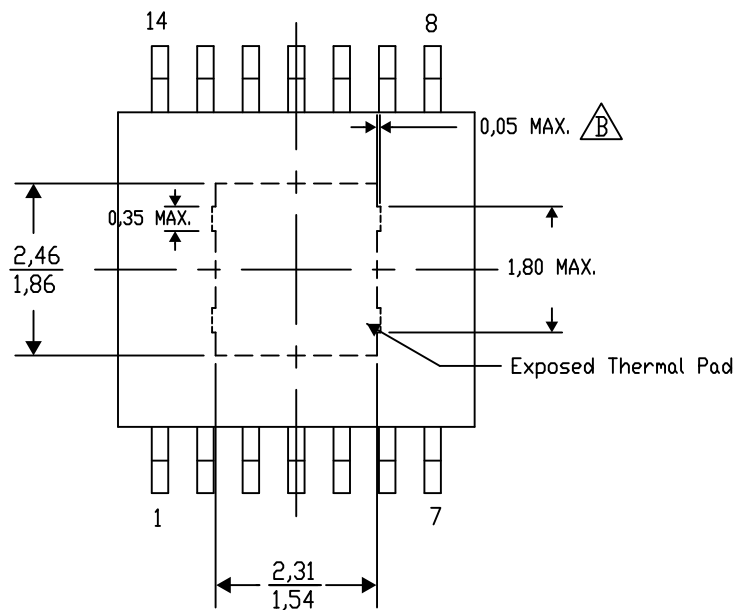

Top View

Exposed Thermal Pad Dimensions

4206332-44/AO 01/16

NOTE: A. All linear dimensions are in millimeters

$\triangle B$ Exposed tie strap features may not be present.

PowerPAD is a trademark of Texas Instruments

PWP (R-PDSO-G14)

PowerPAD™ PLASTIC SMALL OUTLINE

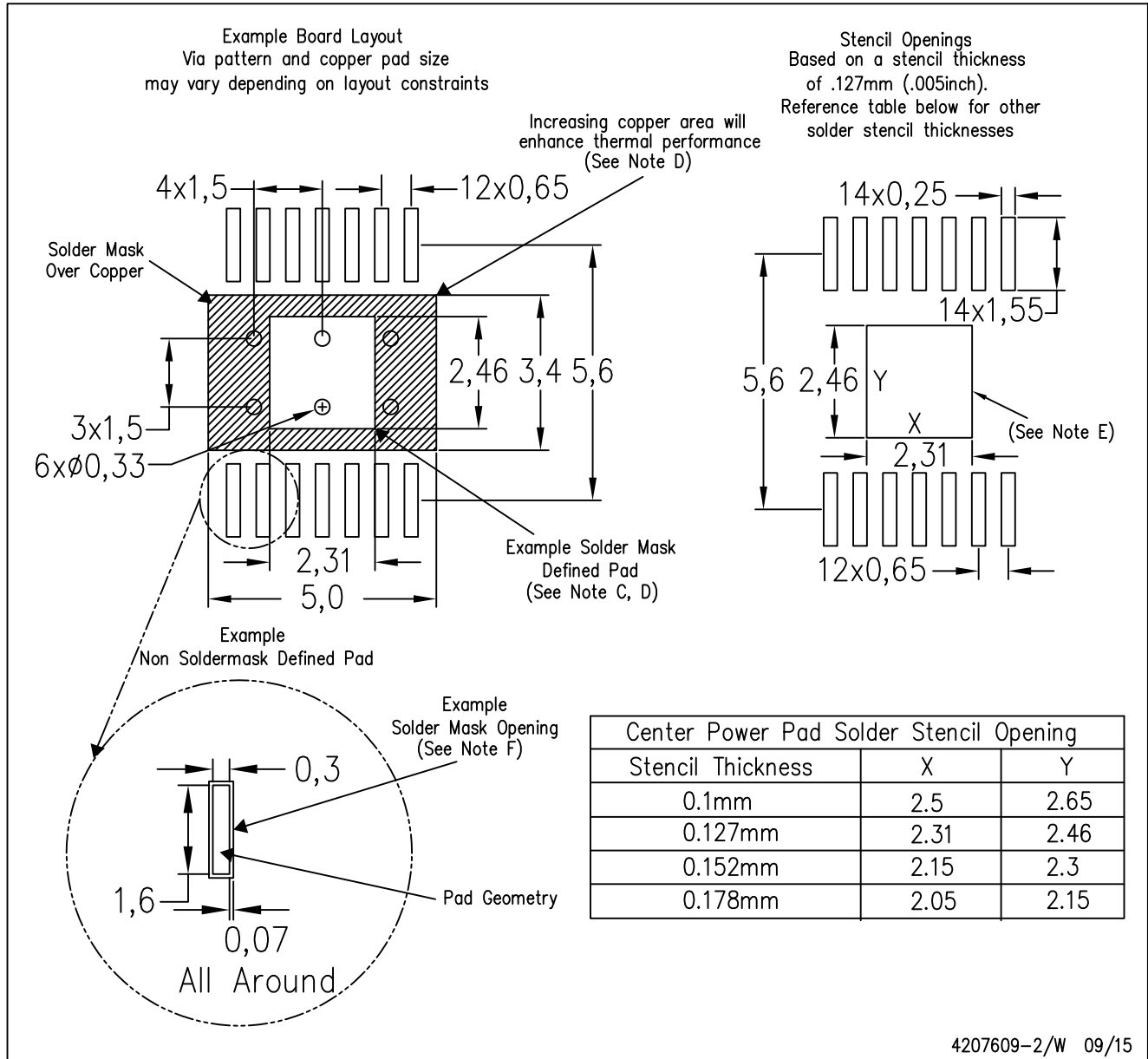

- NOTES:
- A. All linear dimensions are in millimeters.
 - B. This drawing is subject to change without notice.
 - C. Customers should place a note on the circuit board fabrication drawing not to alter the center solder mask defined pad.
 - D. This package is designed to be soldered to a thermal pad on the board. Refer to Technical Brief, PowerPAD Thermally Enhanced Package, Texas Instruments Literature No. SLMA002, SLMA004, and also the Product Data Sheets for specific thermal information, via requirements, and recommended board layout. These documents are available at www.ti.com <<http://www.ti.com>>. Publication IPC-7351 is recommended for alternate designs.
 - E. Laser cutting apertures with trapezoidal walls and also rounding corners will offer better paste release. Customers should contact their board assembly site for stencil design recommendations. Example stencil design based on a 50% volumetric metal load solder paste. Refer to IPC-7525 for other stencil recommendations.
 - F. Customers should contact their board fabrication site for solder mask tolerances between and around signal pads.

IMPORTANT NOTICE AND DISCLAIMER

TI PROVIDES TECHNICAL AND RELIABILITY DATA (INCLUDING DATASHEETS), DESIGN RESOURCES (INCLUDING REFERENCE DESIGNS), APPLICATION OR OTHER DESIGN ADVICE, WEB TOOLS, SAFETY INFORMATION, AND OTHER RESOURCES "AS IS" AND WITH ALL FAULTS, AND DISCLAIMS ALL WARRANTIES, EXPRESS AND IMPLIED, INCLUDING WITHOUT LIMITATION ANY IMPLIED WARRANTIES OF MERCHANTABILITY, FITNESS FOR A PARTICULAR PURPOSE OR NON-INFRINGEMENT OF THIRD PARTY INTELLECTUAL PROPERTY RIGHTS.

These resources are intended for skilled developers designing with TI products. You are solely responsible for (1) selecting the appropriate TI products for your application, (2) designing, validating and testing your application, and (3) ensuring your application meets applicable standards, and any other safety, security, or other requirements. These resources are subject to change without notice. TI grants you permission to use these resources only for development of an application that uses the TI products described in the resource. Other reproduction and display of these resources is prohibited. No license is granted to any other TI intellectual property right or to any third party intellectual property right. TI disclaims responsibility for, and you will fully indemnify TI and its representatives against, any claims, damages, costs, losses, and liabilities arising out of your use of these resources.

TI's products are provided subject to TI's Terms of Sale (www.ti.com/legal/termsofsale.html) or other applicable terms available either on ti.com or provided in conjunction with such TI products. TI's provision of these resources does not expand or otherwise alter TI's applicable warranties or warranty disclaimers for TI products.

Mailing Address: Texas Instruments, Post Office Box 655303, Dallas, Texas 75265
Copyright © 2020, Texas Instruments Incorporated