

Evaluation Board User's Guide for ADC12C170: 12-Bit, 170 MSPS Analog to Digital Converter

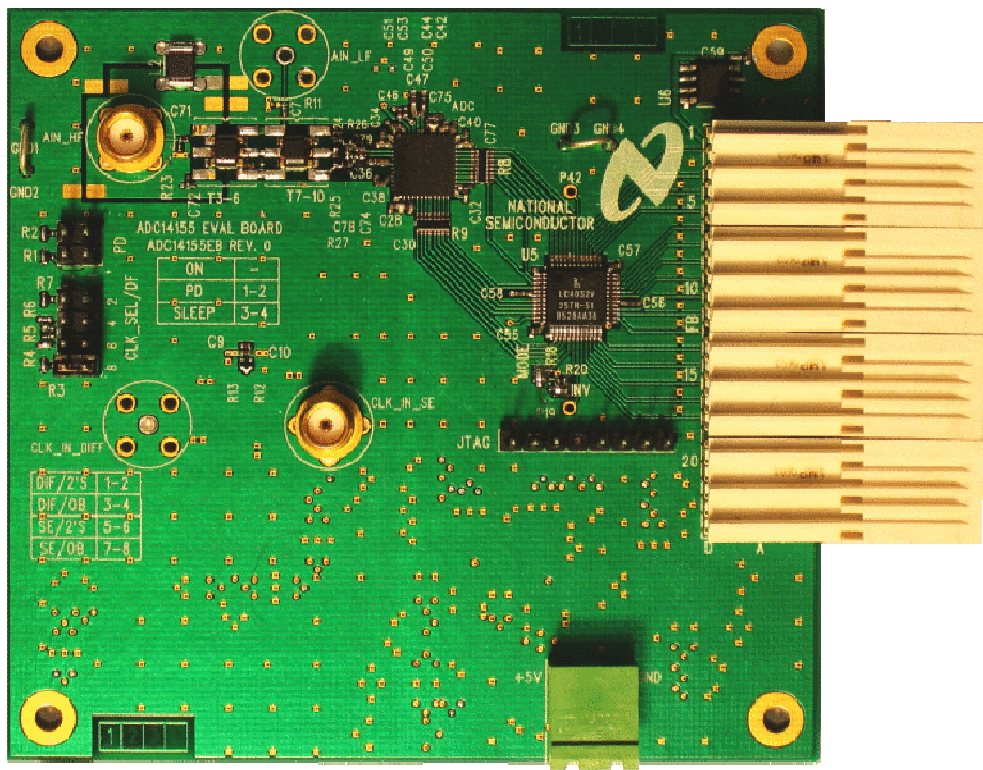

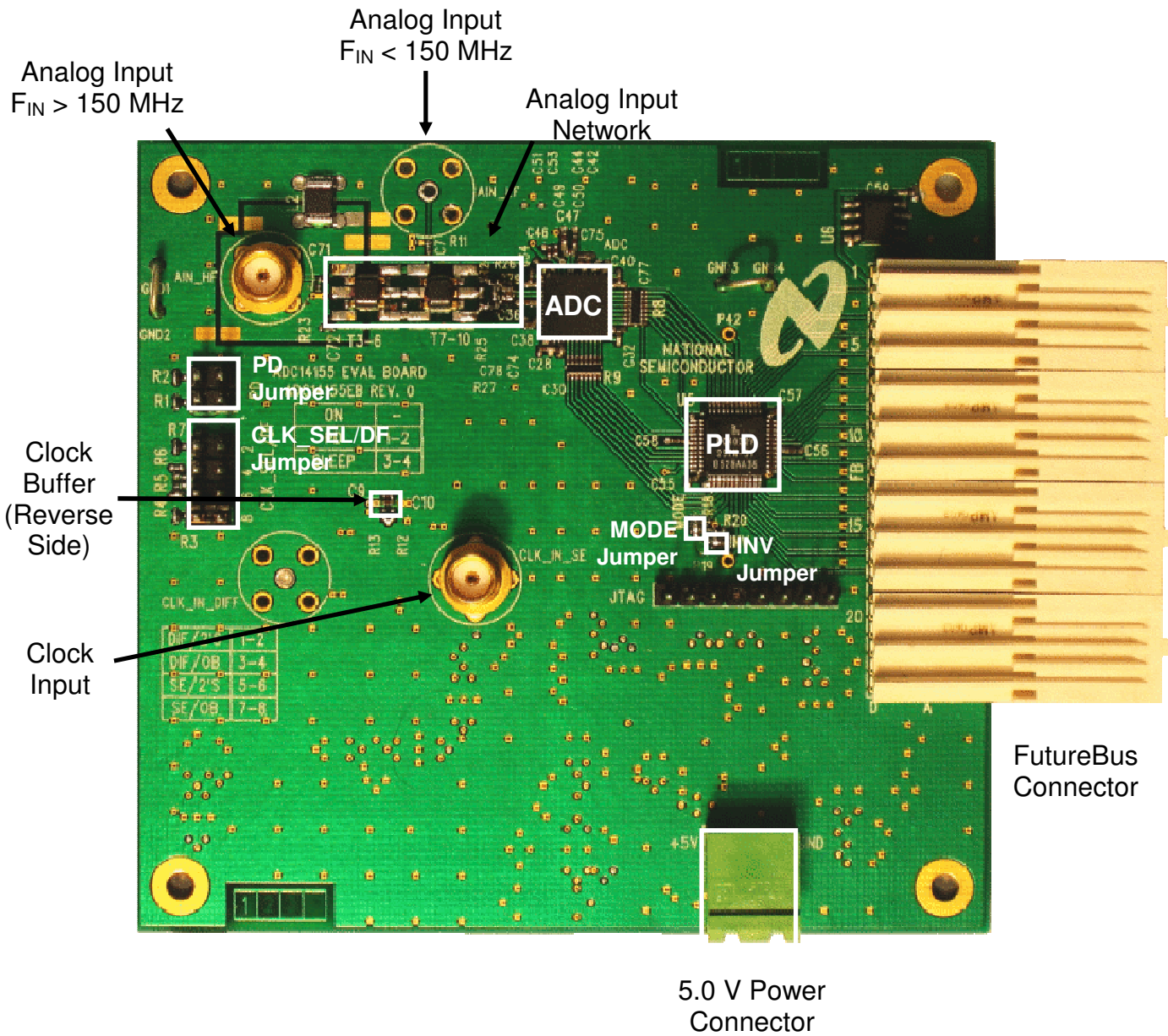

Figure 1. ADC12C170 Evaluation Board Connector and Jumper Locations

1.0 Introduction

The ADC12C170 Evaluation Board is designed to support the ADC12C170 12-bit 170 Mega Sample Per Second (MSPS) ADC.

The ADC12C170 Evaluation Board comes in two versions:

1. ADC12C170HFEB (high frequency version) for input frequencies greater than 150 MHz.
2. ADC12C170LFEB (low frequency version) for input frequencies less than 150 MHz.

The digital data from the ADC12C170 can be captured with a suitable instrument, such as a logic analyzer, connected through the FutureBus connector (schematic reference designator FB) on the ADC12C170XXEB (where XX = HF or LF) or with National Semiconductor's WaveVision 4.0 Digital Interface Board and associated WaveVision software package, which allows fast and easy data acquisition and analysis. The WaveVision hardware connects to a host PC via a USB cable and is fully configured and controlled by the latest WaveVision software. The WaveVision software and WaveVision 4.0 ADC evaluation hardware are available through the National Semiconductor website:

<http://www.national.com/appinfo/adc/wv4.html>.

2.0 Board Assembly

Each evaluation board is configured for single-ended clock operation and is populated with an analog input network which has been optimized for one of two analog input frequencies ranges:

1. ADC12C170HFEB (high frequency version) for input frequencies greater than 170 MHz.
2. ADC12C170LFEB (low frequency version) for input frequencies less than 170 MHz.

Please refer to the input circuit configurations described in the Analog Input Section (4.2) of this guide.

The location and description of the components on the ADC12C170 evaluation board can be found in Section 5.0 (Schematic) and Section 7.0 (Bill of Materials), respectively, of this user's guide.

3.0 Quick Start

The ADC12C170XXEB (where XX = HF or LF) enables easy set up for evaluating the performance of the ADC12C170.

If the WaveVision 4 data acquisition and data analysis system is to be used for capturing data from the

ADC12C170XXEB, please follow the Quick Start Guide in the WaveVision 4 User's Guide to install the required software and to connect the WaveVision 4.0 Digital Interface Board to the PC and to the ADC12C170XXEB.

3.1 Evaluation Board Jumper Positions

Please refer to Figure 1 for the exact jumper locations. The ADC12C170XXEB jumpers should be configured as follows:

1. J1 on the reverse of the board should be shorted.
2. MODE and INV jumpers on the front of the board should be shorted. See Section 4.4 for more detailed information regarding the function of the MODE and INV jumpers.
3. The PD jumper places the ADC12C170 into either powerdown or sleep mode. Table 1 below shows how to select between the power state.

PD Jumper Setting	Mode
Open	Normal Operation
1-2	Power-down
3-4	Sleep

Table 1. CLK_SEL/DF Selection Table

4. CLK_SEL/DF pin jumpers select the output data format (2's complement or offset binary) and clock mode (single-ended or differential). Table 2 below shows how to select between the clock modes and output data formats. Please note that the ADC12C170XXEB is delivered with the ADC12C170 clock input configured for single-ended operation.

CLK_SEL/DF Jumper Setting	Clock Mode	Output Data Format
1-2	Differential	2's Complement
3-4	Differential	Offset Binary
5-6	Single-Ended	2's Complement
7-8*	Single-Ended	Offset Binary

* As assembled from factory.

Table 2. CLK_SEL/DF Selection Table

3.2 Connecting Power and Signal Sources

1. To power the ADC12C170XXEB, connect a 5.0V power supply capable of supplying up to 600mA to the green power connector labeled "+5V" which is located along the bottom edge of the ADC12C170XXEB.
2. Use the FutureBus connector (FB) to connect the ADC12C170XXEB to the instrument being used to capture the data from the evaluation board. If the WaveVision 4.0 Digital Interface Board is being used for data capture, a 5.0V supply capable of supplying up to 400mA is needed. See the WaveVision 4 User's Guide for details on installing

and operating the WaveVision 4.0 hardware and software system.

3. Connect the clock and signal inputs to the CLK_IN_SE and AIN_XX (where XX = HF or LF) SMA connectors, respectively.

4.0 Functional Description

4.1 Clock Input

The clock used to sample the analog input should be applied to the CLK_IN_SE SMA connector (if using the single-ended clock mode).

To achieve the best noise performance (best SNR), a low jitter clock source with total additive jitter less than 150 fs should be used. A low jitter crystal oscillator is recommended, but a sinusoidal signal generator with low phase noise, such as the HP8644B, can also be used with a slight degradation in the noise performance. The noise performance of the ADC12C170 can be improved further by making the edge transitions of the clock signal entering the ADC clock input (pin 11, CLK+) very sharp. The ADC12C170XXEB is assembled with a high speed buffer gate (NC7WV125K8X, schematic reference designator U2) in the clock input path to provide a sharp clock edge to the clock inputs and improve the noise performance of the ADC.

Placing a bandpass filter between the clock source and the CLK_IN_SE SMA connector will further improve the noise performance of the ADC by filtering out the broadband noise of the clock source. All results in the

ADC12C170 datasheet are obtained with a tunable bandpass filter made by Trilithic, Inc. (Indianapolis, IN) in the clock signal path.

4.2 Analog Input

To obtain the best distortion results (best SFDR), the analog input network on the evaluation board must be optimized for the signal frequency being applied.

For analog input frequencies up to approximately 150 MHz, the circuit in Figure 2 is recommended. This is the configuration of the assembled ADC12C170LFEB as it is delivered from the factory. Frequencies above 150 MHz, the circuit in Figure 3 is recommended. This is the configuration of the assembled ADC12C170HFEB as it is delivered from the factory.

A low noise signal generator such as the HP8644B is recommended to drive the signal input of the ADC12C170XXEB. A low pass filter must be used to sufficiently suppress the harmonic distortion produced by the signal generator and to allow accurate measurement of the ADC12C170 distortion performance. In some cases, a second low pass filter may be necessary. Alternatively, a bandpass filter can be used to filter the distortion products of the signal generator. The bandpass filter will further improve the noise performance of the ADC by filtering the broadband noise of the signal generator. Data shown in the ADC12C170 datasheet was taken with a tunable bandpass filter made by Trilithic (Indianapolis, IN) in the analog signal path.

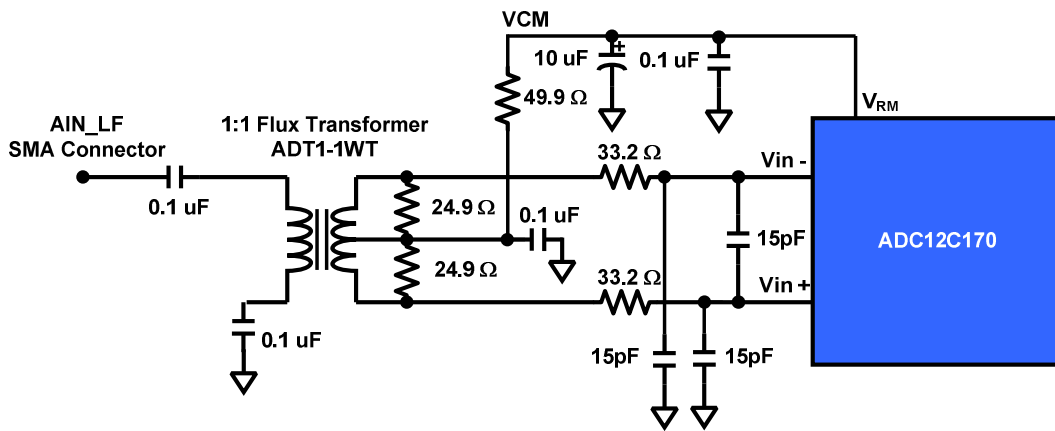

Figure 2. Analog Input Network of ADC12C170LFEB: $F_{IN} < 150$ MHz

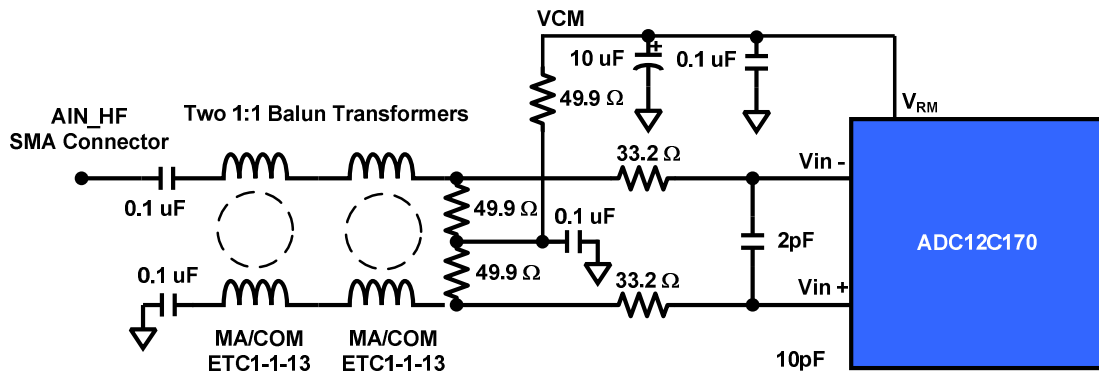

Figure 3. Analog Input Network of ADC12C170HFEB: $F_{IN} > 150$ MHz

4.3 ADC Reference and Input Common Mode

The internal 1.0V reference on the ADC12C170 is used to acquire all of the results in the ADC12C170 datasheet. It is recommended to use the internal reference on the ADC12C170. However, if an external reference is required, the ADC12C170 is capable of accepting an external reference voltage between 0.9V and 1.1V (1.0V recommended). If an external reference is to be used, the ADC12C170XXEB includes a REF test point which can be used to apply the external reference to the ADC.

It is recommended to use the voltage at the V_{RM} pin (pin 45) of the ADC12C170 to provide the 1.5V common mode voltage required for the differential analog inputs V_{IN+} and V_{IN-} . The ADC12C170XXEB is factory-assembled with V_{RM} connected to the transformer center-tap through a 49.9Ω resistor to provide the necessary common mode voltage to the differential analog input. If an external common mode voltage is to be used, the ADC12C170XXEB includes a VCM test point which can be used to apply the external common mode voltage to the ADC.

4.4 Board Outputs

The digitized 12-bit output word from the ADC12C170XXEB is available at pins B4 (MSB) through B15 (LSB) on the FutureBus connector (schematic reference designator FB). The data ready (DRDY) signal which should be used to capture the output data is available at pin D2 of the FutureBus connector and the over-range (OVR) bit which indicates that the input signal to the ADC has exceeded the maximum digitizable signal amplitude is available at pin B18 on the FutureBus connector. See the Evaluation Board schematic in Section 5.0 for details.

The ADC12C170XXEB uses a PLD device from Lattice Semiconductor (LC4032V-25TN48C, schematic reference designator U5) to translate the ADC output

from 1.8V CMOS to 3.3V CMOS, which is compatible with the WaveVision 4.0 Digital Interface Board and other data capture instruments which the user may choose.

The ADC12C170XXEB has been designed to give the user the flexibility to choose between passing the data from the ADC to the capture instrument either with or without latching the data in the PLD. Tables 3 and 4 show how to configure the PLD device through the MODE and INV jumpers on the evaluation board to enable the latching capability. The ADC12C170XXEB is factory assembled with both the MODE and INV jumpers shorted.

MODE Jumper	Data Transfer Through PLD
Short	Latch data with DRDY signal
Open	Pass data transparently without latching

Table 3. PLD Data Transfer Selection Table

The data from the ADC12C170 in the PLD can be latched either on the rising or falling edge of DRDY. Table 4 shows how to choose which edge of DRDY will be used to latch the ADC data into the PLD.

INV Jumper	DRDY Latching Edge
Short	Falling
Open	Rising

Table 4. PLD Latch Edge Selection Table

4.5 Power requirements.

Power to the ADC12C170XXEB is supplied through the green power connector labeled "+5V" which is located along the bottom edge of the board. Voltage and current requirements are:

- +5V at 600mA (ADC12C170XXEB only)
- +5V at 1.0 A (ADC12C170XXEB and WaveVision 4.0 Digital Interface Board)

5.0 Schematic (cont.)

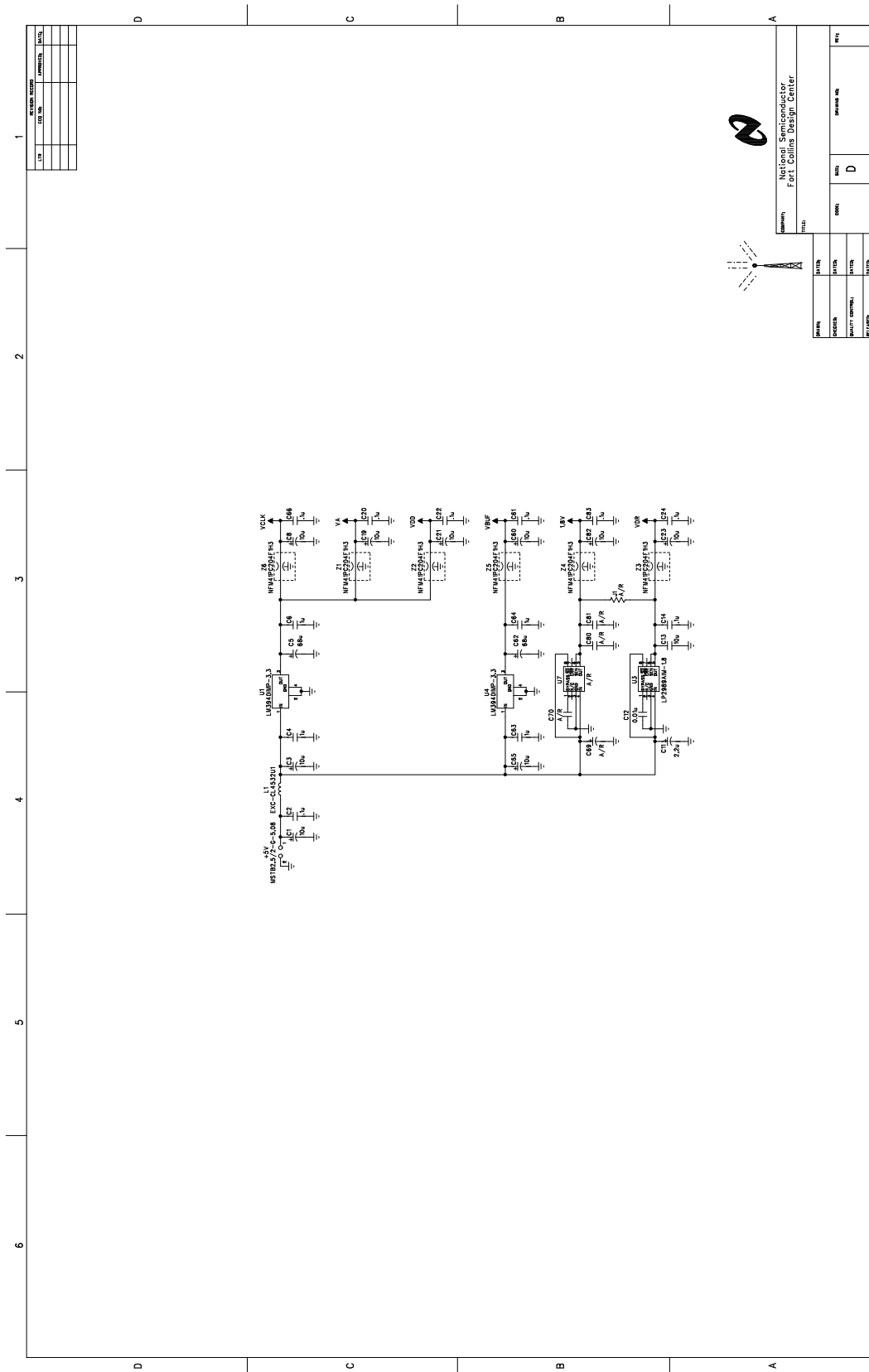

Figure 5. Power Distribution

6.0 Evaluation Board Layout

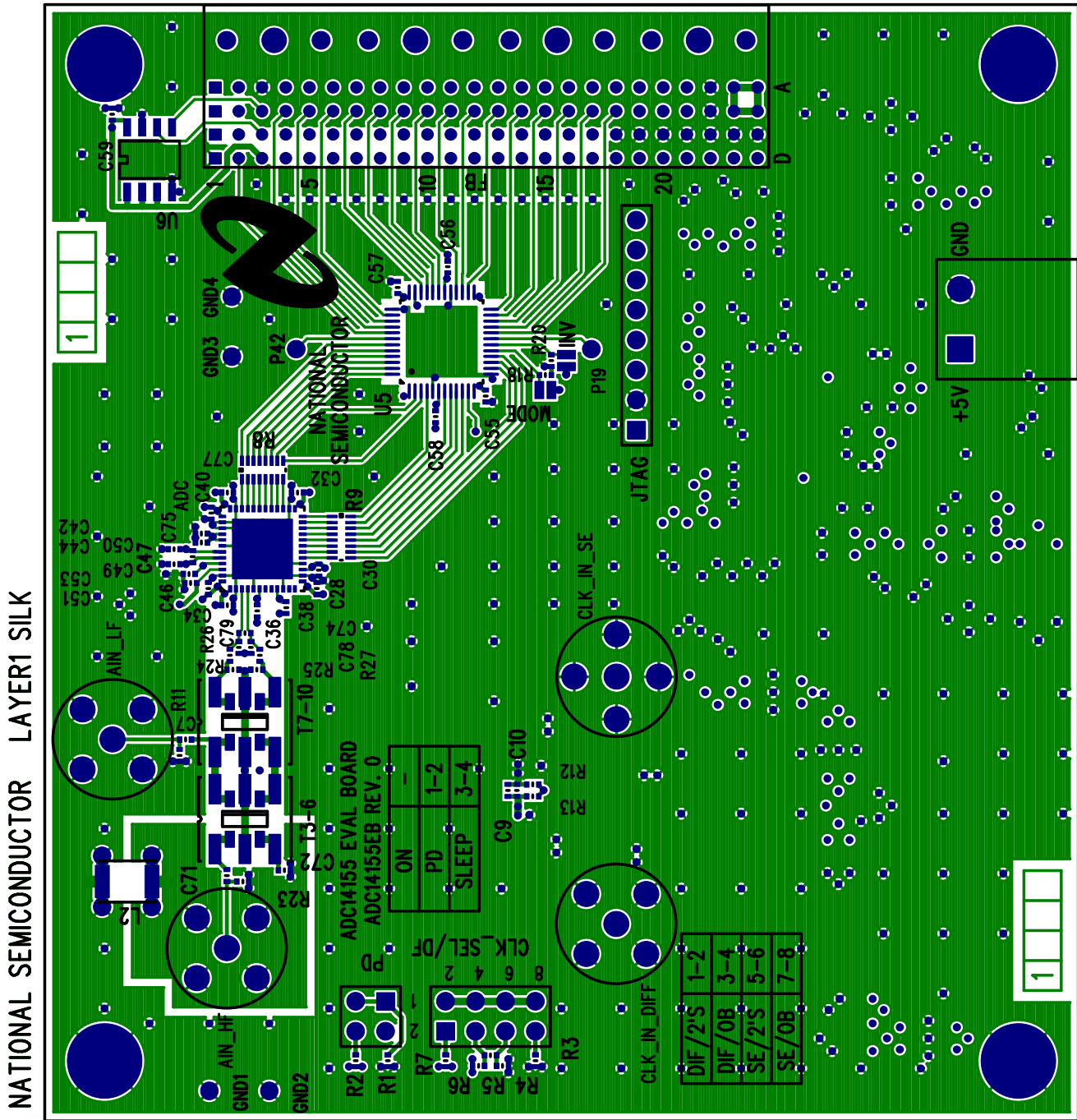

Figure 6. Layer 1 - Signal

6.0 Evaluation Board Layout (cont.)

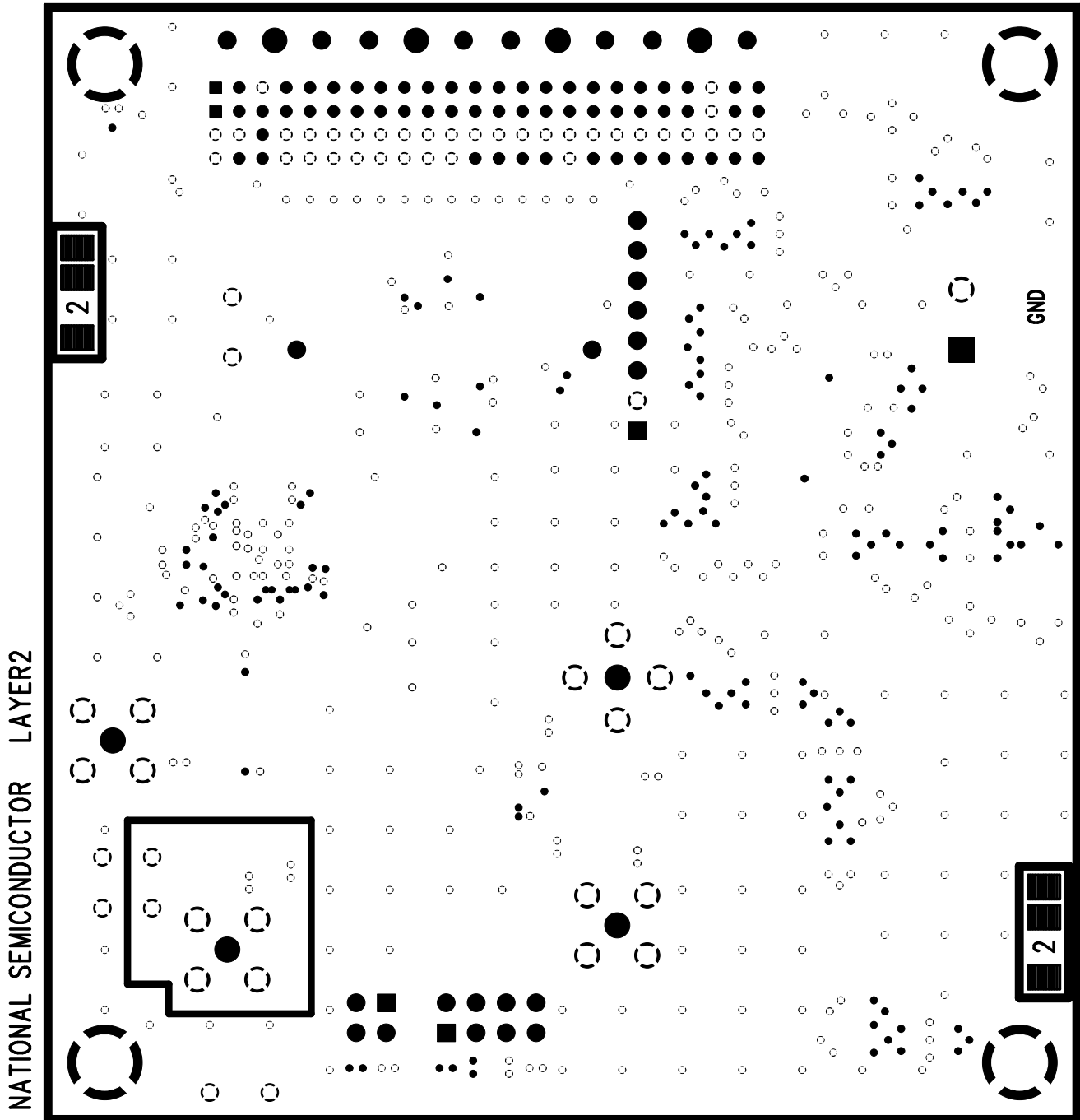

Figure 7. Layer 2 - Ground

6.0 Evaluation Board Layout (cont.)

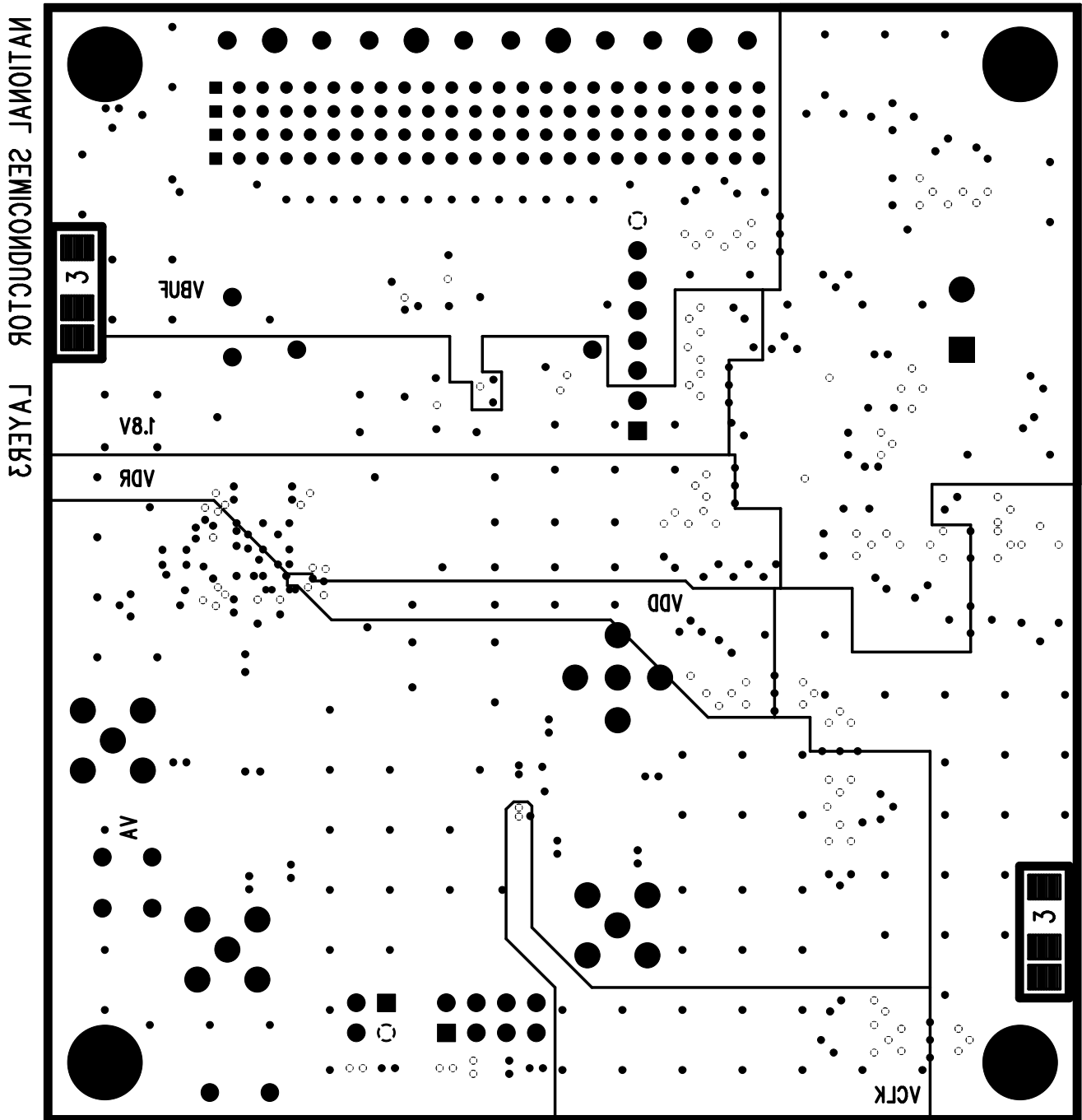

Figure 8. Layer 3 - Power

6.0 Evaluation Board Layout (cont.)

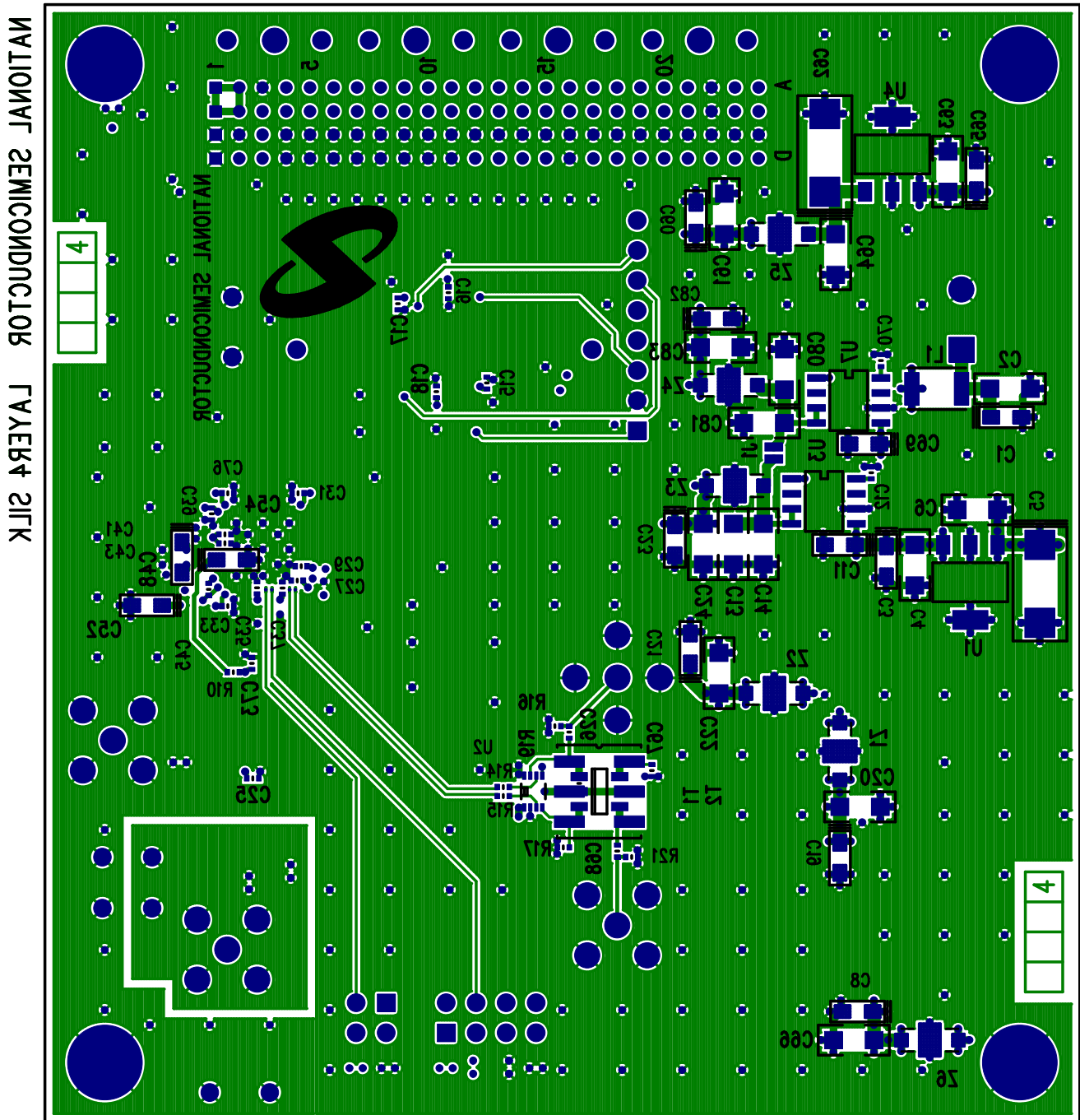

Figure 9. Layer 4 - Signal

7.0 Evaluation Board Bill of Materials

7.1 ADC12C170HFEB (For Fin > 150 MHz)

Item	Quantity	Schematic Reference	Part Name	Description	PCB Footprint	Manufacturer
1	1	U6	24C02	2K SERIAL EEPROM 1.8V	SOIC-8	Atmel
2	1	ADC	ADC12170	12-Bit, 170 MSPS Analog/Digital Converter	48-LLP	National Semiconductor
3	2	T6, T10	ETC1-1-13	BALUN TRANSFORMER		MA/COM
4	4	FB	AMP 5223514-1	Z-PACK 2mm FB (Futurebus+) RIGHT ANGLE HEADER CONNECTOR	-	AMP
5	1	C75	0.1uF	0.1uF SMD CAP CERAMIC 6.3V X5R 10%	sm/c_0201	Panasonic - ECG
6	8	C2, C14, C20, C22, C24, C61, C66, C83	0.1uF	0.1uF SMD CAP CERAMIC 25V X7R 10%	sm/c_1206	Panasonic - ECG
7	26	C9, C15-18, C26-27, C29, C31, C33, C35, C37, C39, C41, C43, C45, C47, C49-51, C53, C59, C71, C72, C73, C76	0.1uF	0.1uF SMD CAP CERAMIC 10V X5R 10%	sm/c_0402	Panasonic - ECG
8	17	C10, C12, C28, C30, C32, C34, C36, C38, C40, C42 C44, C46, C55-58, C77	0.01uF	0.01uF SMD CAP CERAMIC 16V X7R 10%	sm/c_0402	AVX Corporation
9	1	C13	10uF	10uF SMD CAP CERAMIC 10V X5R 20%	sm/c_1206	Panasonic - ECG
10	1	C74	2pF	2pF SMD CAP CERAMIC 50v +/-0.25pF	sm/c_0402	Murata Electronics
11	4	C4, C6, C63-64	1uF	1uF SMD CAP CERAMIC 25V X7R 10%	sm/c_1206	Panasonic - ECG
12	12	C1, C3, C8, C19, C21, C23, C48, C52, C54, C60, C65, C82	10uF	10uF SMD CAP TANTALUM 6.3V 20%	sm/c_3216	Kemet
13	1	C11	2.2uF	2.2uF SMD CAP TANTALUM 16V 10%	sm/c_3216	Kemet
14	2	C5, C62	68uF	68uF SMD CAP TANTALUM 6.3V 10%	sm/c_7343	Kemet
15	2	R8-9	8x22 ohm	22 OHM SMD 8 RES ARRAY 5%	sm/r_0402 x 8	Panasonic -ECG
16	2	L1, L2	Ferrite Bead Core	SMD FERRITE BEAD CORE 4.5X3.2X1.8	-	Panasonic -ECG
17	1	JTAG	Jumper 1x8	JUMPER BLOCK USING 8 PIN SIP HEADER	-	Samtec
18	1	PD	Jumper 2X2	2X2 JUMPER BLOCK HEADER CUT TO SIZE FROM 2X6 HEADER	-	Samtec
19	1	CLK_SEL/DF	Jumper 2X4	2X4 JUMPER BLOCK HEADER CUT TO SIZE FROM 2X6 HEADER	-	Samtec
20	1	-	Shunt	PLACE SHUNT ACROSS PINS 7-8 ON CLK_SEL/DF JUMPER	-	FCI Electronic
21	1	U5	PLD	ispMACH PLD, 3.3V core	48-TQFP	Lattice Semiconductor
22	2	U1, U4	3.3V Regulator	1A LOW DROPOUT REGULATOR FOR 5V TO 3.3 V CONVERSION	SOT-223	National Semiconductor
23	1	U3	1.8V Regulator	MICROPOWER/LOW NOISE, 500 mA ULTRA LOW-DROPOUT REGULAT	SOIC NARROW -8	National Semiconductor
24	1	+5V	Power Connector Terminal Block	TERMINAL BLOCK 2POS 5.08mm	-	Phoenix Contact
25	1	-	Power Connector Plug	TERMINAL BLOCK PLUG 2POS 5.08mm	-	Phoenix Contact
26	4	MT1-4	Bump-on Rubber Feet	PLACE BUMP ONS AT THE 4 CORNERS, ON BOTTOM OF BOARD	-	3M
27	1	U2	Tinylogic Buffer	TINYLOGIC ULP-A BUFFER WITH 3-STATE OUTPUT 8-LEAD US8, JEDEC MO-187, CA 3.1 mm WIDE	-	Fairchild Semiconductor
28	6	Z1-6	Noise Suppression Filter	FILTER LC HIGH FREQ .2UF	1806	Murata Electronics
29	2	J1, MODE	Solder Short	SOLDER SHORT ACROSS THE PADS OF "J1" AND ACROSS PADS OF "MODE"	-	-
30	2	R17, R19	0 ohms	0 OHM SMD RESISTOR	sm/r_0402	Vishay Dale
31	11	R1-7, R12-13, R18, R20	1 kOHM	1 KOHM SMD RESISTOR 1/16W 1%	sm/r_0402	Panasonic - ECG
32	2	R14-15	24.9 ohms	24.9 OHM SMD RESISTOR 1/16W 1%	sm/r_0402	Yageo Corporation
33	2	R26-27	33.2 ohms	33.2 OHM SMD RESISTOR 1/16W 1%	sm/r_0402	Vishay Dale
34	3	R10, R24-25	49.9 ohms	49.9 OHM SMD RESISTOR 1/16W 1%	sm/r_0402	Yageo Corporation
35	2	AIN_HF, CLK_IN_SE	SMA Input	PCB MOUNTABLE SMA CONNECTOR	-	Emerson Network Power Connectivity

7.0 Evaluation Board Bill of Materials (cont.)

7.2 ADC12C170LFEB (For Fin < 150 MHz)

Item	Quantity	Schematic Reference	Part Name	Description	PCB Footprint	Manufacturer
1	1	U6	24C02	2K SERIAL EEPROM 1.8V	SOIC-8	Atmel
2	1	ADC	ADC12170	12-Bit, 170 MSPS Analog/Digital Converter	48-LLP	National Semiconductor
3	1	T7	ADT1-1WT+	WIDEBAND RF TRANSFORMER 0.4MHz - 800 MHz	CD542	MINI CIRCUITS
4	4	FB	AMP_5223514-1	Z-PACK 2mm FB (Futurebus+) RIGHT ANGLE HEADER CONNECTOR	-	AMP
5	1	C75	0.1uF	0.1uF SMD CAP CERAMIC 6.3V X5R 10%	sm/c_0201	Panasonic - ECG
6	8	C2, C14, C20, C22, C24, C61, C66, C83	0.1uF	0.1uF SMD CAP CERAMIC 25V X7R 10%	sm/c_1206	Panasonic - ECG
7	26	C7, C9, C15-18, C25, C26-27, C29, C31, C33, C35, C37, C39, C41, C43, C45, C47, C49-51, C53, C59, C73, C76	0.1uF	0.1uF SMD CAP CERAMIC 10V X5R 10%	sm/c_0402	Panasonic - ECG
8	17	C10, C12, C28, C30, C32, C34, C36, C38, C40, C42, C44, C46, C55-58, C77	0.01uF	0.01uF SMD CAP CERAMIC 16V X7R 10%	sm/c_0402	AVX Corporation
9	1	C13	10uF	10uF SMD CAP CERAMIC 10V X5R 20%	sm/c_1206	Panasonic - ECG
10	3	C74, C78-79	15pF	15pF SMD CAP CERAMIC 50v NP0 5%	sm/c_0402	Panasonic - ECG
11	4	C4, C6, C63-64	1uF	1uF SMD CAP CERAMIC 25V X7R 10%	sm/c_1206	Panasonic - ECG
12	12	C1, C3, C8, C19, C21, C23, C48, C52, C54, C60, C65, C82	10uF	10uF SMD CAP TANTALUM 6.3V 20%	sm/c_3216	Kemet
13	1	C11	2.2uF	2.2uF SMD CAP TANTALUM 16V 10%	sm/c_3216	Kemet
14	2	C5, C62	68uF	68uF SMD CAP TANTALUM 6.3V 10%	sm/c_7343	Kemet
15	2	R8-9	8x22 ohm	22 OHM SMD 8 RES ARRAY 5%	sm/r_0402 x 8	Panasonic -ECG
16	1	L1	Ferrite Bead Core	SMD FERRITE BEAD CORE 4.5X3.2X1.8	-	Panasonic -ECG
17	1	JTAG	Jumper 1x8	JUMPER BLOCK USING 8 PIN SIP HEADER	-	Samtec
18	1	PD	Jumper 2X2	2X2 JUMPER BLOCK HEADER CUT TO SIZE FROM 2X6 HEADER	-	Samtec
19	1	CLK_SEL/DF	Jumper 2X4	2X4 JUMPER BLOCK HEADER CUT TO SIZE FROM 2X6 HEADER	-	Samtec
20	1	-	Shunt	PLACE SHUNT ACROSS PINS 7-8 ON CLK_SEL/DF JUMPER	-	FCI Electronic
21	1	U5	PLD	ispMACH PLD, 3.3V core	48-TQFP	Lattice Semiconductor
22	2	U1, U4	3.3V Regulator	1A LOW DROPOUT REGULATOR FOR 5V TO 3.3 V CONVERSION	SOT-223	National Semiconductor
23	1	U3	1.8V Regulator	MICROPOWER/LOW NOISE, 500 mA ULTRA LOW-DROPOUT REGULATI	SOIC NARROW -8	National Semiconductor
24	1	+5V	Power Connector Terminal Block	TERMINAL BLOCK 2POS 5.08mm	-	Phoenix Contact
25	1	-	Power Connector Plug	TERMINAL BLOCK PLUG 2POS 5.08mm	-	Phoenix Contact
26	4	MT1-4	Bump-on Rubber Feet	PLACE BUMP ONS AT THE 4 CORNERS, ON BOTTOM OF BOARD	-	3M
27	1	U2	Tinylogic Buffer	TINYLOGIC ULP-A BUFFER WITH 3-STATE OUTPUT 8-LEAD US8, JEDEC MO-187, CA 3.1 mm WIDE	-	Fairchild Semiconductor
28	6	Z1-6	Noise Suppression Filter	FILTER LC HIGH FREQ .2UF	1806	Murata Electronics
29	2	J1, MODE	Solder Short	SOLDER SHORT ACROSS THE PADS OF "J1" AND ACROSS PADS OF "MODE"	-	-
30	2	R17, R19	0 ohms	0 OHM SMD RESISTOR	sm/r_0402	Vishay Dale
31	11	R1-7, R12-13, R18, R20	1 kOHM	1 kOHM SMD RESISTOR 1/16W 1%	sm/r_0402	Panasonic - ECG
32	4	R14-15, R24-25	24.9 ohms	24.9 OHM SMD RESISTOR 1/16W 1%	sm/r_0402	Yageo Corporation
33	2	R26-27	33.2 ohms	33.2 OHM SMD RESISTOR 1/16W 1%	sm/r_0402	Vishay Dale
34	1	R10	49.9 ohms	49.9 OHM SMD RESISTOR 1/16W 1%	sm/r_0402	Yageo Corporation
35	2	AIN_LF, CLK_IN_SE	SMA Input	PCB MOUNTABLE SMA CONNECTOR	-	Emerson Network Power Connectivity

The ADC12C170 Evaluation Board is intended for product evaluation purposes only and is not intended for resale to end consumers, is not authorized for such use and is not designed for compliance with European EMC Directive 89/336/EEC.

WaveVision is a trademark of National Semiconductor Corporation. National does not assume any responsibility for use of any circuitry or software supplied or described. No circuit patent licenses are implied.

LIFE SUPPORT POLICY

NATIONAL'S PRODUCTS ARE NOT AUTHORIZED FOR USE AS CRITICAL COMPONENTS IN LIFE SUPPORT DEVICES OR SYSTEMS WITHOUT THE EXPRESS WRITTEN APPROVAL OF THE PRESIDENT OF NATIONAL SEMICONDUCTOR CORPORATION. As used herein:

1. Life support devices or systems are devices or systems which, (a) are intended for surgical implant into the body, or (b) support or sustain life, and whose failure to perform, when properly used in accordance with instructions for use provided in the labeling, can be reasonably expected to result in a significant injury to the user.
2. A critical component is any component in a life support device or system whose failure to perform can be reasonably expected to cause the failure of the life support device or system, or to affect its safety or effectiveness.

	National Semiconductor Corporation Americas Tel: 1-800-272-9959 Fax: 1-800-737-7018 Email: support@nsc.com	National Semiconductor Europe Fax: +49 (0) 1 80-530 85 86 Email: europe.support@nsc.com Deutsch Tel: +49 (0) 1 80-530 85 85 English Tel: +49 (0) 1 80 532 78 32	National Semiconductor Asia Pacific Customer Response Group Tel: 65-2544466 Fax: 65-2504466 Email: sea.support@nsc.com	National Semiconductor Japan Ltd. Tel: 81-3-5639-7560 Fax: 81-3-5639-7507
---	--	--	--	--

National does not assume any responsibility for any circuitry described, no circuit patent licenses are implied and National reserves the right at any time without notice to change said circuitry and specifications.

IMPORTANT NOTICE

Texas Instruments Incorporated and its subsidiaries (TI) reserve the right to make corrections, modifications, enhancements, improvements, and other changes to its products and services at any time and to discontinue any product or service without notice. Customers should obtain the latest relevant information before placing orders and should verify that such information is current and complete. All products are sold subject to TI's terms and conditions of sale supplied at the time of order acknowledgment.

TI warrants performance of its hardware products to the specifications applicable at the time of sale in accordance with TI's standard warranty. Testing and other quality control techniques are used to the extent TI deems necessary to support this warranty. Except where mandated by government requirements, testing of all parameters of each product is not necessarily performed.

TI assumes no liability for applications assistance or customer product design. Customers are responsible for their products and applications using TI components. To minimize the risks associated with customer products and applications, customers should provide adequate design and operating safeguards.

TI does not warrant or represent that any license, either express or implied, is granted under any TI patent right, copyright, mask work right, or other TI intellectual property right relating to any combination, machine, or process in which TI products or services are used. Information published by TI regarding third-party products or services does not constitute a license from TI to use such products or services or a warranty or endorsement thereof. Use of such information may require a license from a third party under the patents or other intellectual property of the third party, or a license from TI under the patents or other intellectual property of TI.

Reproduction of TI information in TI data books or data sheets is permissible only if reproduction is without alteration and is accompanied by all associated warranties, conditions, limitations, and notices. Reproduction of this information with alteration is an unfair and deceptive business practice. TI is not responsible or liable for such altered documentation. Information of third parties may be subject to additional restrictions.

Resale of TI products or services with statements different from or beyond the parameters stated by TI for that product or service voids all express and any implied warranties for the associated TI product or service and is an unfair and deceptive business practice. TI is not responsible or liable for any such statements.

TI products are not authorized for use in safety-critical applications (such as life support) where a failure of the TI product would reasonably be expected to cause severe personal injury or death, unless officers of the parties have executed an agreement specifically governing such use. Buyers represent that they have all necessary expertise in the safety and regulatory ramifications of their applications, and acknowledge and agree that they are solely responsible for all legal, regulatory and safety-related requirements concerning their products and any use of TI products in such safety-critical applications, notwithstanding any applications-related information or support that may be provided by TI. Further, Buyers must fully indemnify TI and its representatives against any damages arising out of the use of TI products in such safety-critical applications.

TI products are neither designed nor intended for use in military/aerospace applications or environments unless the TI products are specifically designated by TI as military-grade or "enhanced plastic." Only products designated by TI as military-grade meet military specifications. Buyers acknowledge and agree that any such use of TI products which TI has not designated as military-grade is solely at the Buyer's risk, and that they are solely responsible for compliance with all legal and regulatory requirements in connection with such use.

TI products are neither designed nor intended for use in automotive applications or environments unless the specific TI products are designated by TI as compliant with ISO/TS 16949 requirements. Buyers acknowledge and agree that, if they use any non-designated products in automotive applications, TI will not be responsible for any failure to meet such requirements.

Following are URLs where you can obtain information on other Texas Instruments products and application solutions:

Products

Audio	www.ti.com/audio
Amplifiers	amplifier.ti.com
Data Converters	dataconverter.ti.com
DLP® Products	www.dlp.com
DSP	dsp.ti.com
Clocks and Timers	www.ti.com/clocks
Interface	interface.ti.com
Logic	logic.ti.com
Power Mgmt	power.ti.com
Microcontrollers	microcontroller.ti.com
RFID	www.ti-rfid.com
OMAP Mobile Processors	www.ti.com/omap
Wireless Connectivity	www.ti.com/wirelessconnectivity

Applications

Automotive and Transportation	www.ti.com/automotive
Communications and Telecom	www.ti.com/communications
Computers and Peripherals	www.ti.com/computers
Consumer Electronics	www.ti.com/consumer-apps
Energy and Lighting	www.ti.com/energy
Industrial	www.ti.com/industrial
Medical	www.ti.com/medical
Security	www.ti.com/security
Space, Avionics and Defense	www.ti.com/space-avionics-defense
Video and Imaging	www.ti.com/video

TI E2E Community Home Page

e2e.ti.com

Mailing Address: Texas Instruments, Post Office Box 655303, Dallas, Texas 75265
Copyright © 2012, Texas Instruments Incorporated