

## SCH3227/SCH3226/SCH3224/SCH3222 Silicon Errata and Data Sheet Clarifications

**TABLE 1: SILICON DEV/REV VALUES**

Part Number	STRAPOPT <sup>(3)</sup>	Device ID <sup>(1)</sup>	Revision ID for Silicon Revision <sup>(2)</sup>
			A
SCH3222	--	7Fh	02h
SCH3224	--	7Fh	02h
SCH3226	0 (low)	7Dh	02h
SCH3226	1 (high)	7Fh	02h
SCH3227	0 (low)	7Dh	02h
SCH3227	1 (high)	7Fh	02h

**Note 1:** The Device ID is visible as an 8-bit number at Plug and Play Configuration Index 20h.  
**Note 2:** The HW Revision Number is visible as an 8-bit number at Plug and Play Configuration Index 21h and Version/Stepping Number Register 3Fh.  
**Note 3:** STRAPOPT is a pin that is present on the SCH3226 and SCH3227 devices only. It affects the pinout and also the Device ID code, as shown above.

**TABLE 2: SILICON ISSUE SUMMARY**

Module	Feature	Item Number	Issue Summary	Affected Revisions <sup>(1)</sup>
				A
Serial Port	Reset	1.	Resetting UART 3 and UART 4 with PCI_RST	X

**Note 1:** If there are multiple revision-letter columns under this one, only those issues indicated in the last column apply to the current silicon revision.

# SCH322x

## Silicon Errata Issues

### 1. Module: Serial Port

UART 3 and UART 4 do not tri-state their outputs on a PCI\_RESET as do UART 1 and UART 2.

UART 3 and UART 4 outputs are not controlled by the Configuration Register 0x30 ACTIVATE bit.

#### END USER IMPLICATIONS

UART 3 and UART 4 outputs will drive High when PCI\_RESET goes active or when the ACTIVATE bit is cleared, and if the platform uses RTS to control an RS485 transceiver this may interrupt communication.

#### Work Around

Use GPIO pin to disable RS485 transceiver when ACTIVATE bit is cleared.

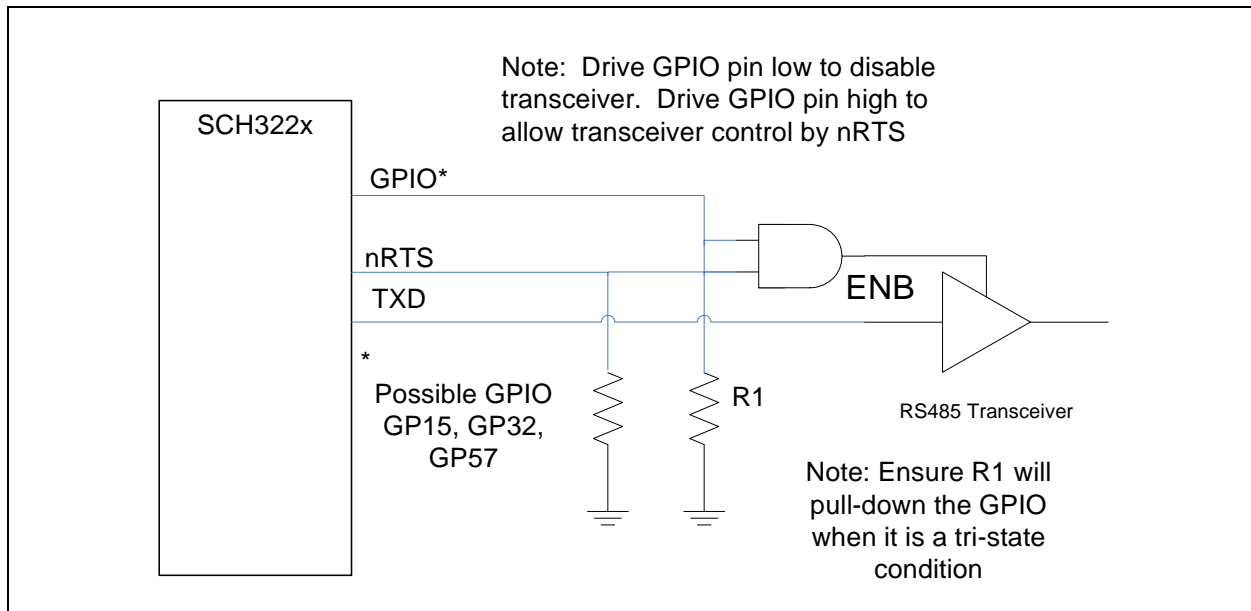

## Data Sheet Clarifications

**Note:** The following typographic corrections and clarifications apply to Data Sheet Document #00002121A, which is at Revision A, and specifies only the family members SCH3222, SCH3224, SCH3226 and SCH3227. Other members of the SCH322x family have separate data sheets, and separate errata sheets.

**TABLE 3: DATA SHEET CLARIFICATION SUMMARY**

Module	Item Number	Issue Summary
Temp Monitor and Fan Control	1.	Incorrect offset for PME_EN1
Temp Monitor and Fan Control	2.	No Support for HWM SMI Events
Power Control	3.	32KHz Clock Required for PB_IN# and PB_OUT#
8042 Keyboard Controller	4.	Incorrect Register for Keyboard/Mouse Swap
Programmable Clock Output	5.	Misleading Label in Figure
Temp Monitor and Fan Control	6.	Incorrect Values in Table
Temp Monitor and Fan Control	7.	No Hardware Monitor Interrupt Event on SERIRQ
Runtime Registers	8.	Inconsistent Default for Keyboard PWRBTN Runtime Register
Runtime Registers	9.	Inconsistent Default for Runtime Registers
LPC Timing Diagrams	10.	Inconsistent PCI Clock Max Period

### 1. Module: Temperature Monitoring and Fan Control

The section “Interrupt as a PME Event,” refers to the PME\_EN1 register at offset 0Ah. The offset for PME\_EN1 is 08h.

### 2. Module: Temperature Monitoring and Fan Control

The section “Interrupt as an SMI Event,” is incorrect. Hardware monitoring interrupts are not routed to the SMI block and do not generate SMI events. The section will be removed in its entirety.

### 3. Module: Power Control Features

A clock is required on CLKI32 (pin 99) to clock in and debounce PB\_IN# and to assert PB\_OUT#. If CLKI32 is either not connected or is not connected to an active clock, PB\_OUT# will not be asserted. CLKI32 should be connected to a 32KHz clock. A clock can be provided for PB\_IN# by connecting CLKI32 to the SUSCLK output from the core logic south bridge.

### 4. Module: 8042 Keyboard Controller

The section “Keyboard/Mouse Swap Bit” says that there is a bit in the Keyboard Select configuration register at 0xF1 in logical device 7, used for swapping the keyboard and mouse pins. There is no such register. The keyboard/mouse swap bit is located in bit[6] of Runtime Register 0x5C, which is correctly documented.

### 5. Module: Programmable Clock Output

In the figure “Reset Generation Circuit”, there is a signal labeled “RESETB”. The figure implies that the signal comes in from an input pin. This is incorrect. The figure should indicate that the signal is an internally generated Power On Reset signal.

# SCH322x

---

## 6. Module: Temperature Monitoring and Fan Control

The Nominal Voltage and Maximum Voltage numbers in the table "Voltage Limits vs. Register Setting" are incorrect for the row labeled 2.5V. The table indicates the nominal voltage is 5.0V and the maximum voltage is 6.64V. These two values are incorrect.

The correct nominal voltage is 2.5V, matching the signal name. The maximum voltage is 3.32V.

## 7. Module: Temperature Monitoring and Fan Control

In the subsection titled "Interrupt Event on Serial IRQ", in chapter "Temperature Monitoring and Fan Control", it is stated that the interrupt can be routed to the SERIRQ using configuration register 0x70 in Logical Device A. This is not correct. The Hardware Monitor Interrupt cannot be directly routed to a SERIRQ and there is no configuration register 0x70 in Logical Device A. This subsection will be deleted in subsequent releases of the data sheet.

As described in the subsections that precede this one, the Hardware Monitor interrupt can be routed onto a pin, onto an SMI or onto a PME. If it is required to route the HWM interrupt to a SERIRQ, it can be routed to an SMI, which can in turn be routed on SERIRQ2.

## 8. Module: Runtime Registers

The Description column of the Keyboard PWRBTN/SPEKEY runtime register specification states that the default value for bits[5:4], Keyboard Power Button Release, is 00b (De-assert KB\_PB\_STS 0.5sec after it is asserted).

This is inconsistent with the Name column, which states that the VBAT POR default value for bits[5:4] is 10b.

The actual default value is 10b. The system must set bits[5:4] to 00b if that is the desired behavior.

## 9. Module: Runtime Registers

The default POR values listed in the table "Runtime Register POR Summary" are incorrect in two cases. In addition, the default POR value for an additional register is incorrect in both this Summary table and also in the table "Detailed Runtime Register Description". Also, this Register table incorrectly states that register 0x10, PME\_STS7, is reset on VBAT POR. The PME\_STS7 register is reset on VTR POR, as stated in Summary table.

The following table shows the correct POR values for the registers in question:

Runtime Register	Description	VTR POR Default, Summary Table	VTR POR Default, Register Table	Actual VTR POR Default
0x10	PME_EN7	0x00	VBAT POR 0x00	0x00
0x13	SP34	0x00	0x44	0x44
0x4E	GP4	0x00	0xF0	0x05
0x6E	GP44	0x00	0x80	0x80

## 10. Module: LPC Timing Diagrams

In the chapter "Timing Diagrams", section "LPC Interface Timing":

In the table underneath the first figure "PCI Clock Timing", the parameter t1 (Period) is given an incorrect value in the MAX column. It shows 33.3ns, and should instead be 52.6ns, which represents the lowest tested LPC frequency of 19MHz.

## APPENDIX A: DOCUMENT REVISION HISTORY

Revision Level and Date	Section	Description
DS80000694B (09-25-19)	Data Sheet Clarifications, Module #4 - <a href="#">8042 Keyboard Controller</a>	"Runtime Register 0x5" changed to "Runtime Register 0x5C".
DS80000694A (04-11-16)	Initial Draft Version	

## THE MICROCHIP WEB SITE

Microchip provides online support via our WWW site at [www.microchip.com](http://www.microchip.com). This web site is used as a means to make files and information easily available to customers. Accessible by using your favorite Internet browser, the web site contains the following information:

- **Product Support** – Data sheets and errata, application notes and sample programs, design resources, user's guides and hardware support documents, latest software releases and archived software
- **General Technical Support** – Frequently Asked Questions (FAQ), technical support requests, online discussion groups, Microchip consultant program member listing
- **Business of Microchip** – Product selector and ordering guides, latest Microchip press releases, listing of seminars and events, listings of Microchip sales offices, distributors and factory representatives

## CUSTOMER CHANGE NOTIFICATION SERVICE

Microchip's customer notification service helps keep customers current on Microchip products. Subscribers will receive e-mail notification whenever there are changes, updates, revisions or errata related to a specified product family or development tool of interest.

To register, access the Microchip web site at [www.microchip.com](http://www.microchip.com). Under "Support", click on "Customer Change Notification" and follow the registration instructions.

## CUSTOMER SUPPORT

Users of Microchip products can receive assistance through several channels:

- Distributor or Representative
- Local Sales Office
- Field Application Engineer (FAE)
- Technical Support

Customers should contact their distributor, representative or field application engineer (FAE) for support. Local sales offices are also available to help customers. A listing of sales offices and locations is included in the back of this document.

**Technical support is available through the web site at: <http://www.microchip.com/support>**

**Note the following details of the code protection feature on Microchip devices:**

- Microchip products meet the specification contained in their particular Microchip Data Sheet.
- Microchip believes that its family of products is one of the most secure families of its kind on the market today, when used in the intended manner and under normal conditions.
- There are dishonest and possibly illegal methods used to breach the code protection feature. All of these methods, to our knowledge, require using the Microchip products in a manner outside the operating specifications contained in Microchip's Data Sheets. Most likely, the person doing so is engaged in theft of intellectual property.
- Microchip is willing to work with the customer who is concerned about the integrity of their code.
- Neither Microchip nor any other semiconductor manufacturer can guarantee the security of their code. Code protection does not mean that we are guaranteeing the product as “unbreakable.”

Code protection is constantly evolving. We at Microchip are committed to continuously improving the code protection features of our products. Attempts to break Microchip's code protection feature may be a violation of the Digital Millennium Copyright Act. If such acts allow unauthorized access to your software or other copyrighted work, you may have a right to sue for relief under that Act.

---

Information contained in this publication regarding device applications and the like is provided only for your convenience and may be superseded by updates. It is your responsibility to ensure that your application meets with your specifications. MICROCHIP MAKES NO REPRESENTATIONS OR WARRANTIES OF ANY KIND WHETHER EXPRESS OR IMPLIED, WRITTEN OR ORAL, STATUTORY OR OTHERWISE, RELATED TO THE INFORMATION, INCLUDING BUT NOT LIMITED TO ITS CONDITION, QUALITY, PERFORMANCE, MERCHANTABILITY OR FITNESS FOR PURPOSE. Microchip disclaims all liability arising from this information and its use. Use of Microchip devices in life support and/or safety applications is entirely at the buyer's risk, and the buyer agrees to defend, indemnify and hold harmless Microchip from any and all damages, claims, suits, or expenses resulting from such use. No licenses are conveyed, implicitly or otherwise, under any Microchip intellectual property rights unless otherwise stated.

**Trademarks**

The Microchip name and logo, the Microchip logo, Adaptec, AnyRate, AVR, AVR logo, AVR Freaks, BesTime, BitCloud, chipKIT, chipKIT logo, CryptoMemory, CryptoRF, dsPIC, FlashFlex, flexPWR, HELDO, IGLOO, JukeBlox, KeeLoq, Klear, LANCheck, LinkMD, maXStylus, maXTouch, MediaLB, megaAVR, Microsemi, Microsemi logo, MOST, MOST logo, MPLAB, OptoLyzer, PackeTime, PIC, picoPower, PICSTART, PIC32 logo, PolarFire, Prochip Designer, QTouch, SAM-BA, SenGenuity, SpyNIC, SST, SST Logo, SuperFlash, Symmetricom, SyncServer, Tachyon, TempTracker, TimeSource, tinyAVR, UNI/O, Vectron, and XMEGA are registered trademarks of Microchip Technology Incorporated in the U.S.A. and other countries.

APT, ClockWorks, The Embedded Control Solutions Company, EtherSynch, FlashTec, Hyper Speed Control, HyperLight Load, IntelliMOS, Libero, motorBench, mTouch, Powermite 3, Precision Edge, ProASIC, ProASIC Plus, ProASIC Plus logo, Quiet-Wire, SmartFusion, SyncWorld, Temux, TimeCesium, TimeHub, TimePictra, TimeProvider, Vite, WinPath, and ZL are registered trademarks of Microchip Technology Incorporated in the U.S.A.

Adjacent Key Suppression, AKS, Analog-for-the-Digital Age, Any Capacitor, AnyIn, AnyOut, BlueSky, BodyCom, CodeGuard, CryptoAuthentication, CryptoAutomotive, CryptoCompanion, CryptoController, dsPICDEM, dsPICDEM.net, Dynamic Average Matching, DAM, ECAN, EtherGREEN, In-Circuit Serial Programming, ICSP, INICnet, Inter-Chip Connectivity, JitterBlocker, KlearNet, KlearNet logo, memBrain, Mindi, MiWi, MPASM, MPF, MPLAB Certified logo, MPLIB, MPLINK, MultiTRAK, NetDetach, Omniscient Code Generation, PICDEM, PICDEM.net, PICkit, PICtail, PowerSmart, PureSilicon, QMatrix, REAL ICE, Ripple Blocker, SAM-ICE, Serial Quad I/O, SMART-I.S., SQT, SuperSwitcher, SuperSwitcher II, Total Endurance, TSHARC, USBCheck, VariSense, ViewSpan, WiperLock, Wireless DNA, and ZENA are trademarks of Microchip Technology Incorporated in the U.S.A. and other countries.

SQTP is a service mark of Microchip Technology Incorporated in the U.S.A.

The Adaptec logo, Frequency on Demand, Silicon Storage Technology, and Symmcom are registered trademarks of Microchip Technology Inc. in other countries.

GestIC is a registered trademark of Microchip Technology Germany II GmbH & Co. KG, a subsidiary of Microchip Technology Inc., in other countries.

All other trademarks mentioned herein are property of their respective companies.

© 2016-2019, Microchip Technology Incorporated, All Rights Reserved.

ISBN: 9781522450818

*For information regarding Microchip's Quality Management Systems, please visit [www.microchip.com/quality](http://www.microchip.com/quality).*



## Worldwide Sales and Service

### AMERICAS

**Corporate Office**  
2355 West Chandler Blvd.  
Chandler, AZ 85224-6199  
Tel: 480-792-7200  
Fax: 480-792-7277  
Technical Support:  
<http://www.microchip.com/support>  
Web Address:  
[www.microchip.com](http://www.microchip.com)

**Atlanta**  
Duluth, GA  
Tel: 678-957-9614  
Fax: 678-957-1455

**Austin, TX**  
Tel: 512-257-3370

**Boston**  
Westborough, MA  
Tel: 774-760-0087  
Fax: 774-760-0088

**Chicago**  
Itasca, IL  
Tel: 630-285-0071  
Fax: 630-285-0075

**Dallas**  
Addison, TX  
Tel: 972-818-7423  
Fax: 972-818-2924

**Detroit**  
Novi, MI  
Tel: 248-848-4000

**Houston, TX**  
Tel: 281-894-5983

**Indianapolis**  
Noblesville, IN  
Tel: 317-773-8323  
Fax: 317-773-5453  
Tel: 317-536-2380

**Los Angeles**  
Mission Viejo, CA  
Tel: 949-462-9523  
Fax: 949-462-9608  
Tel: 951-273-7800

**Raleigh, NC**  
Tel: 919-844-7510

**New York, NY**  
Tel: 631-435-6000

**San Jose, CA**  
Tel: 408-735-9110  
Tel: 408-436-4270

**Canada - Toronto**  
Tel: 905-695-1980  
Fax: 905-695-2078

### ASIA/PACIFIC

**Australia - Sydney**  
Tel: 61-2-9868-6733

**China - Beijing**  
Tel: 86-10-8569-7000

**China - Chengdu**  
Tel: 86-28-8665-5511

**China - Chongqing**  
Tel: 86-23-8980-9588

**China - Dongguan**  
Tel: 86-769-8702-9880

**China - Guangzhou**  
Tel: 86-20-8755-8029

**China - Hangzhou**  
Tel: 86-571-8792-8115

**China - Hong Kong SAR**  
Tel: 852-2943-5100

**China - Nanjing**  
Tel: 86-25-8473-2460

**China - Qingdao**  
Tel: 86-532-8502-7355

**China - Shanghai**  
Tel: 86-21-3326-8000

**China - Shenyang**  
Tel: 86-24-2334-2829

**China - Shenzhen**  
Tel: 86-755-8864-2200

**China - Suzhou**  
Tel: 86-186-6233-1526

**China - Wuhan**  
Tel: 86-27-5980-5300

**China - Xian**  
Tel: 86-29-8833-7252

**China - Xiamen**  
Tel: 86-592-2388138

**China - Zhuhai**  
Tel: 86-756-3210040

### ASIA/PACIFIC

**India - Bangalore**  
Tel: 91-80-3090-4444

**India - New Delhi**  
Tel: 91-11-4160-8631

**India - Pune**  
Tel: 91-20-4121-0141

**Japan - Osaka**  
Tel: 81-6-6152-7160

**Japan - Tokyo**  
Tel: 81-3-6880-3770

**Korea - Daegu**  
Tel: 82-53-744-4301

**Korea - Seoul**  
Tel: 82-2-554-7200

**Malaysia - Kuala Lumpur**  
Tel: 60-3-7651-7906

**Malaysia - Penang**  
Tel: 60-4-227-8870

**Philippines - Manila**  
Tel: 63-2-634-9065

**Singapore**  
Tel: 65-6334-8870

**Taiwan - Hsin Chu**  
Tel: 886-3-577-8366

**Taiwan - Kaohsiung**  
Tel: 886-7-213-7830

**Taiwan - Taipei**  
Tel: 886-2-2508-8600

**Thailand - Bangkok**  
Tel: 66-2-694-1351

**Vietnam - Ho Chi Minh**  
Tel: 84-28-5448-2100

### EUROPE

**Austria - Wels**  
Tel: 43-7242-2244-39  
Fax: 43-7242-2244-393

**Denmark - Copenhagen**  
Tel: 45-4450-2828  
Fax: 45-4485-2829

**Finland - Espoo**  
Tel: 358-9-4520-820

**France - Paris**  
Tel: 33-1-69-53-63-20  
Fax: 33-1-69-30-90-79

**Germany - Garching**  
Tel: 49-8931-9700

**Germany - Haan**  
Tel: 49-2129-3766400

**Germany - Heilbronn**  
Tel: 49-7131-72400

**Germany - Karlsruhe**  
Tel: 49-721-625370

**Germany - Munich**  
Tel: 49-89-627-144-0  
Fax: 49-89-627-144-44

**Germany - Rosenheim**  
Tel: 49-8031-354-560

**Israel - Ra'anana**  
Tel: 972-9-744-7705

**Italy - Milan**  
Tel: 39-0331-742611  
Fax: 39-0331-466781

**Italy - Padova**  
Tel: 39-049-7625286

**Netherlands - Drunen**  
Tel: 31-416-690399  
Fax: 31-416-690340

**Norway - Trondheim**  
Tel: 47-7288-4388

**Poland - Warsaw**  
Tel: 48-22-3325737

**Romania - Bucharest**  
Tel: 40-21-407-87-50

**Spain - Madrid**  
Tel: 34-91-708-08-90  
Fax: 34-91-708-08-91

**Sweden - Gothenberg**  
Tel: 46-31-704-60-40

**Sweden - Stockholm**  
Tel: 46-8-5090-4654

**UK - Wokingham**  
Tel: 44-118-921-5800  
Fax: 44-118-921-5820