

APPLICATION NOTE 4545

Flexible Overvoltage/Undervoltage Detector Monitors Negative and Positive Voltages

By: Franco Contadini

Bich Pham

Dec 10, 2010

Abstract: Combining a window comparator (MAX6764) with a positive-voltage monitor (MAX6887/MAX6888) enables the circuit to monitor a negative voltage as well, as is often required in telecom systems.

A similar version of this article appeared in the January 1, 2008 issue of *PD* magazine.

Multivoltage supply supervisors (such as the [MAX6887](#)) provide several voltage-detector inputs for positive voltages, each with factory-set thresholds for undervoltage and overvoltage. The active-low RESET output asserts when any input drops below its undervoltage threshold, or when you assert the manual reset (MR). The active-low OV output asserts when any input exceeds its overvoltage threshold. These capabilities are useful, but telecom applications often require that you monitor a negative supply voltage for the RF circuitry as well.

To monitor negative voltage you can make use of the MAX6887 adjustable-input option (**Figure 1**), in which a level-shifting circuit connects one side of the resistive divider to a positive level and the other side to the negative voltage. This approach, however, produces inverted output logic. If, for example, you monitor -6V with thresholds at -6.5V and -5.5V, the circuit asserts active-low UV when $V_{IN} = -6.5V$ and active-low OV when $V_{IN} = -5.5V$.

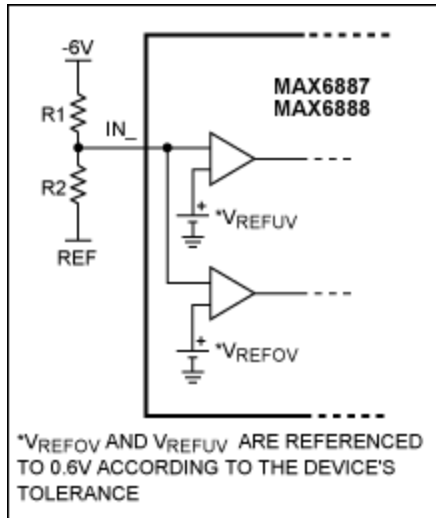

Figure 1. MAX6887 adjustable input option.

The circuit of **Figure 2** overcomes this limitation by adding a simple window-detector IC (**Figure 3**) to monitor the negative supply. The detector's active-low UV output connects to the multivoltage supervisor's active-low OV output, and the detector's active-low OV output connects to the supervisor's active-low RESET output. Thus, the active-low RESET output goes low when the negative voltage decreases to -5.5V, and the active-low OV output asserts low when the negative voltage increases to -6.5V. Three resistors (R1–R3) set the under- and over-voltage thresholds UV and OV. R1 connects to a positive reference voltage, and R3 connects to the monitored negative voltage.

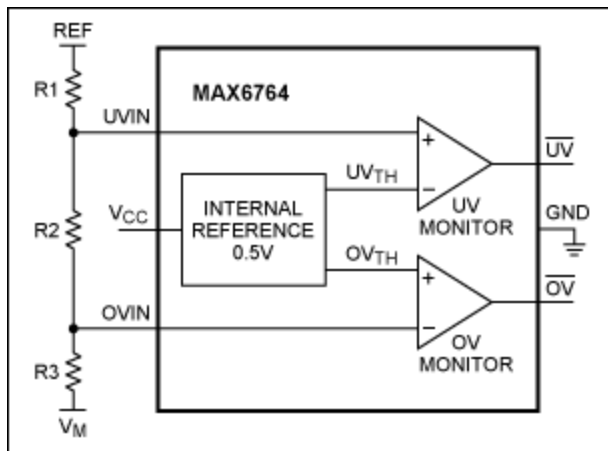

Figure 2. This IC (in SOT23 package) is a simple window comparator that monitors a supply voltage with separate under/overvoltage outputs.

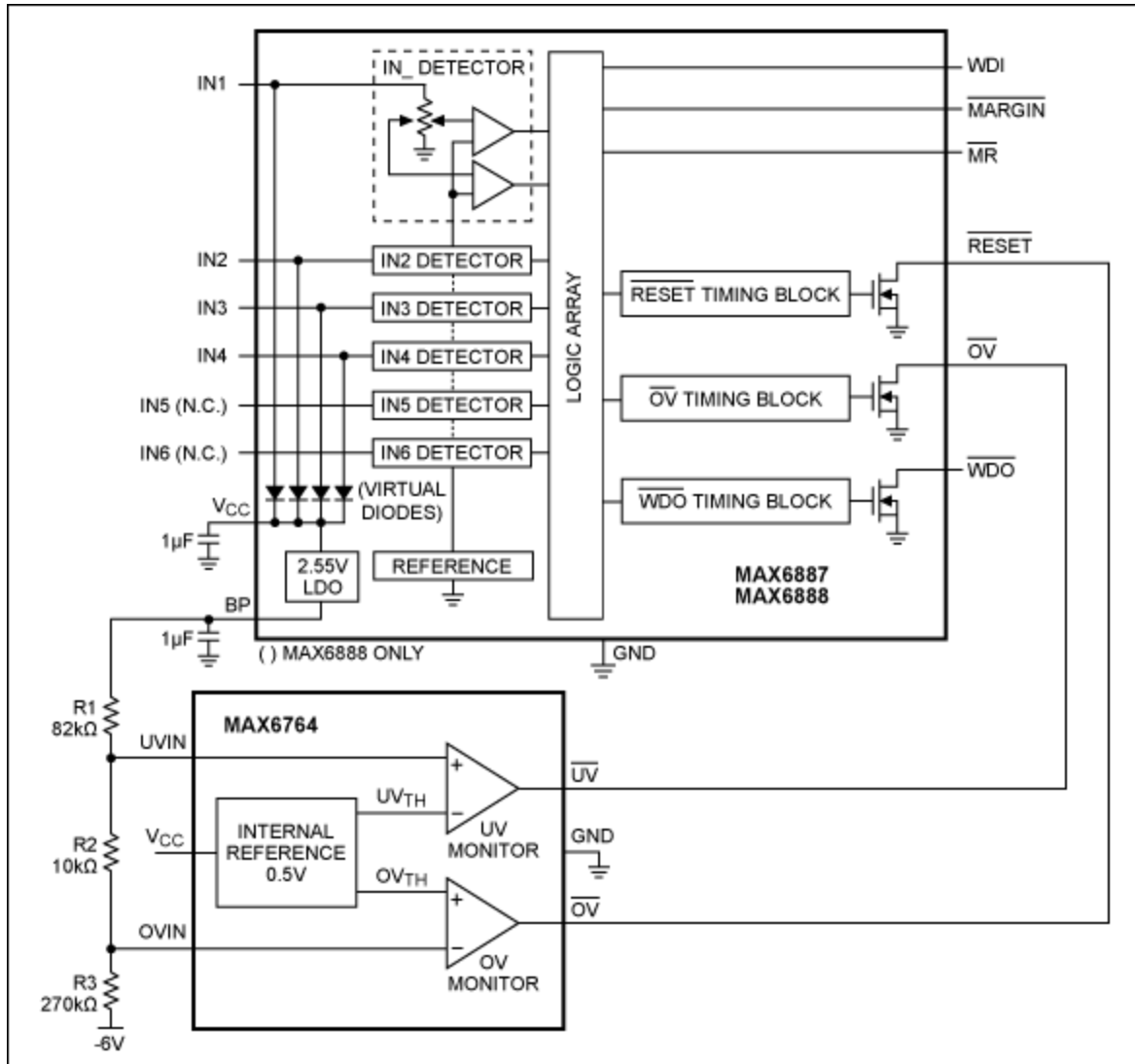

Figure 3. By combining the circuits of Figures 1 and 2, one pair of terminals warns of under- or over-voltage for multiple positive voltages and one negative voltage.

If your system doesn't include a positive reference voltage, you can use the supervisor's 2.55V BP output. To maximize DC accuracy, the sum of R1 + R2 + R3 should draw only a few microamps from the BP output. Using the principle of superposition, you can then calculate the voltages at UVIN and OVIN for any given set of resistor values as follows:

$$V_{UVIN} = V_{BP} \times \left(\frac{R2 + R3}{R1 + R2 + R3} \right) - |V_M| \times \left(\frac{R1}{R1 + R2 + R3} \right),$$

$$V_{OVIN} = V_{BP} \times \left(\frac{R3}{R1 + R2 + R3} \right) - |V_M| \times \left(\frac{R1 + R2}{R1 + R2 + R3} \right),$$

where V_M is the monitored negative supply voltage.

Operation of the Figure 3 circuit is illustrated in the scope shot of Figure 4, in which the yellow trace (CH1) represents the monitored negative voltage V_M as it ranges from 0V to -7V. Other traces are:

R1 (black) = UVIN
 CH2 (blue) = MAX6764 active-low UV
 CH3 (green) = OVIN
 CH4 (pink) = MAX6764 active-low OV

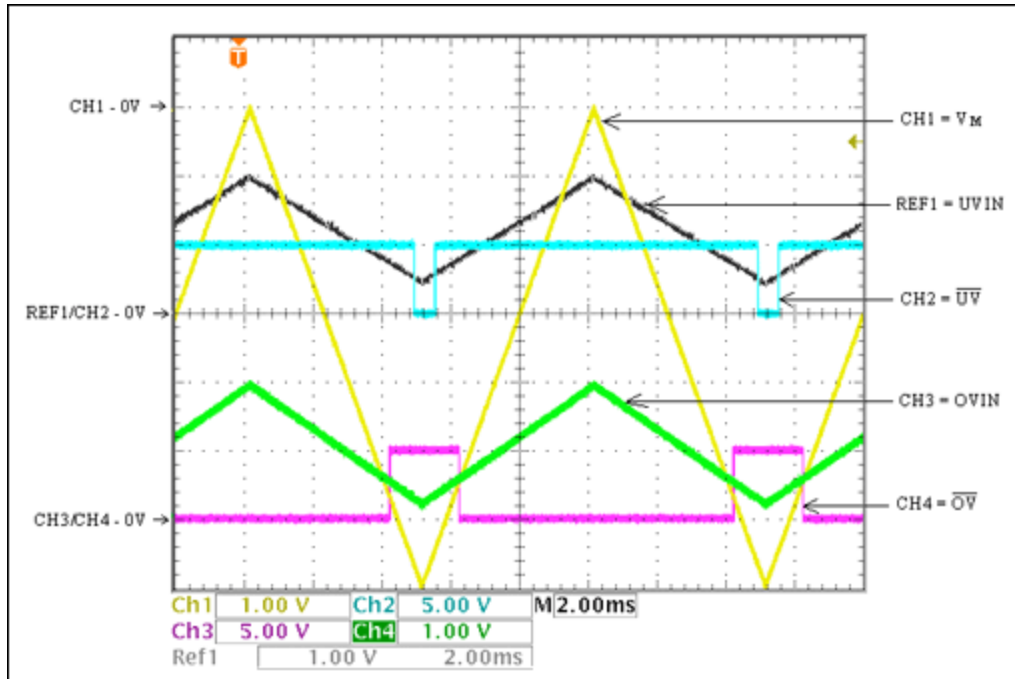

Figure 4. These waveforms illustrate operation of the Figure 3 circuit.

The nominal value for the monitored negative voltage is -6V. Both active-low OV and active-low UV outputs have a 10kΩ pullup to 5V, and the V_{CC} terminals of both ICs connect to a 5V supply. The MAX6764 Output active-low UV (MAX6887 active-low OV Output) goes low at V_M = -6.55V (and goes high at V_M = -6.52V). The MAX6764 output active-low OV (MAX6887 active-low RESET Output) goes low at V_M = -5.53V (and goes high at V_M = -5.55V).

Related Parts

MAX6764	Low-Power, Single/Dual-Voltage Window Detectors	
MAX6887	Hex/Quad, Power-Supply Supervisory Circuits	Free Samples
MAX6888	Hex/Quad, Power-Supply Supervisory Circuits	Free Samples

More Information

For Technical Support: <http://www.maximintegrated.com/support>
 For Samples: <http://www.maximintegrated.com/samples>
 Other Questions and Comments: <http://www.maximintegrated.com/contact>

Application Note 4545: <http://www.maximintegrated.com/an4545>
 APPLICATION NOTE 4545, AN4545, AN 4545, APP4545, Appnote4545, Appnote 4545

Copyright © by Maxim Integrated Products
Additional Legal Notices: <http://www.maximintegrated.com/legal>