

MIC7400/MIC7401

I²C Configurable Power Management IC (PMIC)

Summary

The MIC7400/7401 is a powerful, highly-integrated, configurable, power-management IC (PMIC) featuring high-speed I²C interface with an internal EEPROM. The device has five 3A synchronous buck regulators with high-speed adaptive on-time control, supporting even the challenging ultra-fast transient requirement for Core supplies. One boost regulator provides a flash-memory programming supply that delivers up to 200 mA of output current. The boost is equipped with an output disconnect switch that opens if a short-to-ground fault is detected. All switchers provide light-load efficiency with HyperLight Load[®] mode for buck and PFM mode for boost.

The device offers two distinct modes of operation “stand-by mode” and “normal mode” intended to provide an energy optimized solution suitable for portable handheld and infotainment applications. The MIC7401 also includes a global enable pin to shutdown the device for additional power savings.

In normal mode, the programmable switching converters can be configured to support a variety of start-up sequencing, timing, soft-start ramp, output voltage levels, current limit levels, and output discharge for each channel.

In stand-by mode, activated either by I²C or the external STBY pin, the PMIC can be configured in a low-power state by either disabling an output or by changing the output voltage to a lower level.

An internal EEPROM enables a single-chip solution across many platforms by allowing the designer to customize the PMIC for their design. Modifications can be made without the need to re-approve a new PMIC, saving valuable design resources and time.

The MIC7400/7401 supplies are designed for use with inexpensive small value inductors and capacitors enabling a total solution size of 15 × 14.5 mm and less than 1 mm height.

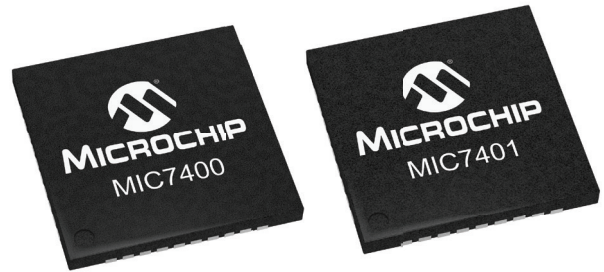

Applications

- Client/enterprise Solid State Drives (SSD)
- Consumer/in-vehicle infotainment systems
- Multimedia/computing devices
- Security cameras
- Applications/graphics processors

Board Space Required

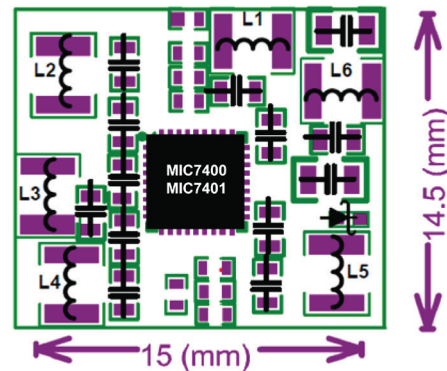

| Benefits | Features |
|----------------------|---|
| Ultra-Small Solution | <ul style="list-style-type: none">■ High-density five-channel, independent, 3A synchronous buck regulators■ One-channel independent 200 mA boost regulator■ I²C interface up to 3.4 MHz■ 4.5 × 4.5 × 0.85 mm FQFN package |
| High Performance | <ul style="list-style-type: none">■ 93% peak efficiency■ 1.5% output accuracy over line/load/temperature■ Fast transient response |
| Low-Cost Solution | <ul style="list-style-type: none">■ Higher integration of functions eliminates need for additional ICs■ Use of low-cost passives allowed■ Minimal external components |
| Flexibility | <ul style="list-style-type: none">■ Integrated EEPROM for stored configurations and multi-channel power rails sequencing provide an ideal solution for powering application processors from any vendor |



MICROCHIP

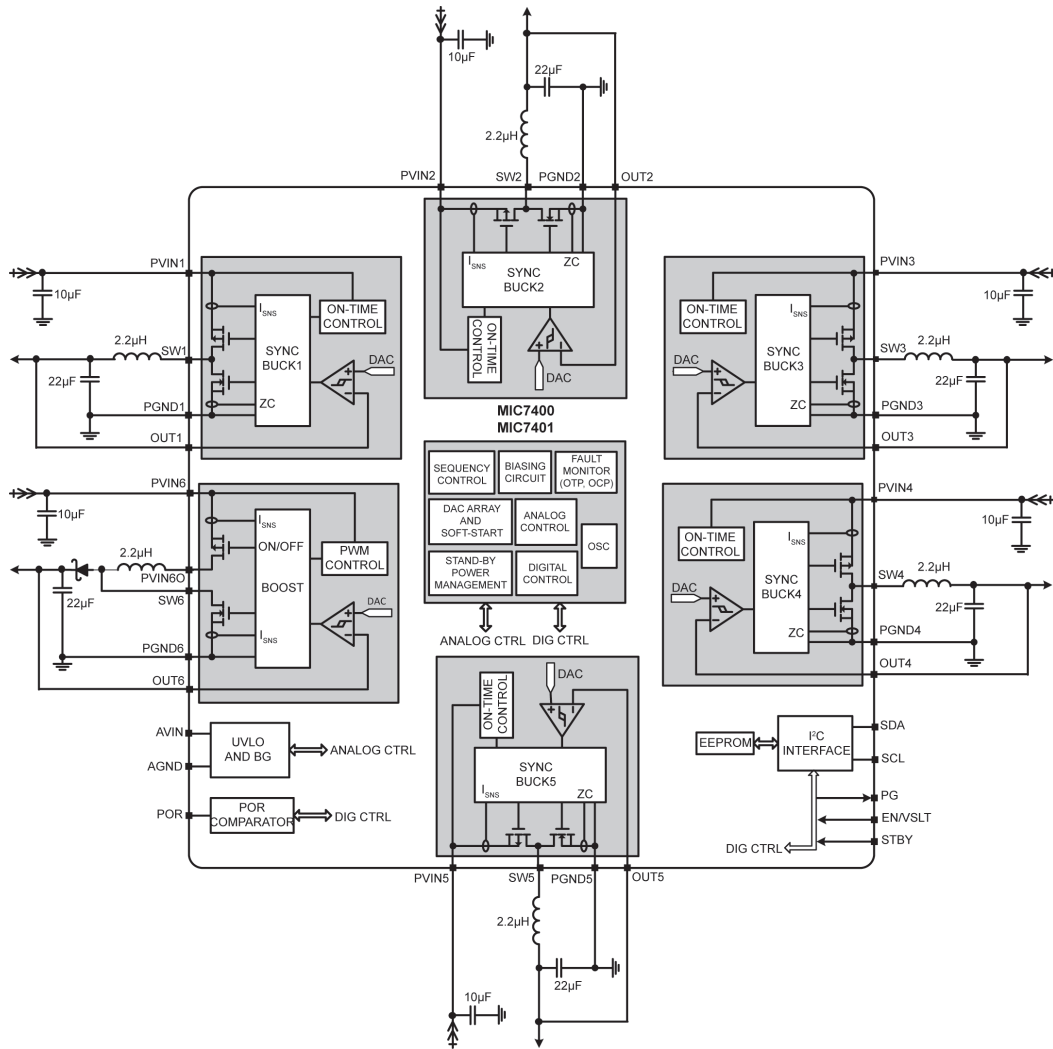

Ordering Information

| Part Number | Marking | Output Voltages | Features | Package |
|--------------------------------|--------------|--|--|--------------------------|
| MIC7400YFL | 7400 | 1.8V, 1.1V, 1.8V, 1.05V, 1.25V, 12V | STBY – Active Low Falling Edge (Default) | 36-pin 4.5 × 4.5 mm FQFN |
| MIC7400-XXXXTFL ⁽¹⁾ | XXXX 7400 | Configurable | Configurable | 36-pin 4.5 × 4.5 mm FQFN |
| MIC7401YFL | 7401 | 1.8V, 1.1V, 1.8V 1.05V, 1.25V, 12V | STBY – Active Low Falling Edge (Default) Global EN Pin | 36-pin 4.5 × 4.5 mm FQFN |
| MIC7401-XXXXYFL ⁽¹⁾ | XXXX 7401 | Configurable | Configurable | 36-pin 4.5 × 4.5 mm FQFN |

Note 1: Contact factory



MICROCHIP
www.microchip.com

Visit our web site for additional product information and to locate your local sales office.

Microchip Technology Inc. • 2355 W. Chandler Blvd. • Chandler, AZ 85224-6199

Microcontrollers • Digital Signal Controllers • Analog • Memory • Wireless

The Microchip name and logo, the Microchip logo and HyperLight Load are registered trademarks of Microchip Technology Incorporated in the U.S.A. and other countries. All other trademarks mentioned herein are property of their respective companies. © 2016, Microchip Technology Incorporated. All Rights Reserved. Printed in the U.S.A. 1/16 DS20005488A