

QUICK START GUIDE FOR DEMONSTRATION CIRCUIT 448

DUAL OUTPUT ISOLATED POWER SUPPLY

LT3710

DESCRIPTION

Demonstration circuit 448 is a dual output high efficiency isolated DC/DC power supply with 36V to 72V input range. It has two outputs: 3.3V at 10A max and 1.8V or 2.5V at 10A max. LT3710, a secondary side synchronous post regulator controller, is used to generate a tightly regulated second output directly from the transformer secondary winding, thus minimizing the size of

the output inductor and capacitor at the first output stage. Synchronous MOSFETs significantly improve efficiency, making it suitable for low output voltage applications. The complete design is mounted within a standard half brick PCB area with about half inch height.

Design files for this circuit board are available. Call the LTC factory.

Table 1. Performance Summary ($T_A = 25^\circ\text{C}$)

PARAMETER	CONDITION	VALUE
Minimum Input Voltage		36V
Maximum Input Voltage		72V
V_{OUT1}	$V_{IN} = 36\text{V to }72\text{V}$, $I_{OUT1} = 0\text{A to }10\text{A}$, $I_{OUT2} = 0\text{A to }10\text{A}$	$3.3\text{V} \pm 2\%$
V_{OUT2}	$V_{IN} = 36\text{V to }72\text{V}$, $I_{OUT1} = 0\text{A to }10\text{A}$, $I_{OUT2} = 0\text{A to }10\text{A}$	$1.83\text{V} \pm 2\%$ (JP1, JP2: 1.8V position) or $2.53\text{V} \pm 2\%$ (JP1, JP2: 2.5V position)
Typical Output Ripple V_{OUT1}	$V_{IN} = 48\text{V}$, $I_{OUT1} = 10\text{A}$ (20MHz BW)	70mV _{p-p}
Typical Output Ripple V_{OUT2}	$V_{IN} = 48\text{V}$, $I_{OUT2} = 10\text{A}$ (20MHz BW)	50mV _{p-p} for 1.8Vo 60mV _{p-p} for 2.5Vo
Output Regulation	Line Load	$\pm 0.1\%$ $\pm 0.2\%$
Nominal Switching Frequency		230kHz
Efficiency	$V_{IN} = 48\text{V}$, $V_{OUT1} = 3.3\text{V}$, $V_{OUT2} = 1.8\text{V}$, $I_{OUT1} = I_{OUT2} = 10\text{A}$ $V_{IN} = 48\text{V}$, $V_{OUT1} = 3.3\text{V}$, $V_{OUT2} = 2.5\text{V}$, $I_{OUT1} = I_{OUT2} = 10\text{A}$	86% Typical 87% Typical
Output Voltage V_{OUT1} Trim	$V_{O1\text{ TRIM}} = 3.3\text{V}$ $V_{O1\text{ TRIM}} = 0\text{V}$	5% Typical -5% Typical
On/Off Control	Logic Low Voltage-Off Logic High Voltage-On	0.6V Max 1V Min
Isolation Voltage	Basic Insulation	1500VDC

OPERATING PRINCIPLES

Demonstration circuit 448A features the LT3710, LT3781 and LTC1698 controllers. The basic power stage topology is a two-switch forward converter with synchronous rectification. The primary side controller uses the LT3781, a current mode two-switch forward controller with built-in MOSFET drivers. On the secondary side, an LTC1698 is used to provide the voltage feedback for the 3.3V output, as well as the gate drive for the synchronous MOSFETs in the 3.3V output stage. The error amplifier output of the 3.3V circuit is fed into the optocoupler and then relayed to LT3781 on the primary side to complete the 3.3V regulation. The second 1.8V/2.5V output is directly regulated by the LT3710 circuit.

A planar transformer PA0191 built by Pulse Engineering is employed as the power transformer in this design. This transformer is constructed on a PQ20 core with nine turns of primary windings, two turns of secondary

windings and seven turns of auxiliary windings for the LT3781 bias supply. A Vishay Si7892DP is used due to its low $R_{DS(ON)}$, 30V V_{DSS} rating and its compact and thermally enhanced PowerPak SO-8 package.

The switching frequency of the circuit is about 230KHz. 1500V input to output isolation is provided. Additional features of this demo board include primary side on/off control, $\pm 5\%$ secondary side trimming on the 3.3V output, input overvoltage protection, under voltage lockout, 3.3V output overvoltage protection, 1.8V/2.5V output current limit and board overtemperature shutdown.

The demo board can deliver the full rated currents (10A at both outputs) at room temperature without airflow. The hottest spot on the demo board (T1 transformer) has a temperature rise of 50°C at 48V input and full loads (without airflow).

QUICK START PROCEDURE

Demonstration circuit DC448 is easy to set up to evaluate the performance of the LT3710, LT3781 and LTC1698. Refer to Figure 1 for proper measurement equipment setup and follow the procedure below:

NOTE: When measuring the input or output voltage ripple, care must be taken to avoid a long ground lead on the oscilloscope probe. Measure the input or output voltage ripple by touching the probe tip directly across the V_{in} or V_{out} and GND terminals. See Figure 2 for proper scope probe technique.

Default jumper setting: both jumpers at 1.8V position

1. Select V_{out2} 1.8V (or 2.5V): Place both jumpers JP1 and JP2 at 1.8V (or 2.5V) position.
2. With power off, connect the input power supply to $+V_{in}$ (36V–72V) and $-V_{in}$ (input return).

3. The on/off control pin should be left open for normal operation. (Connecting the on/off pin to the $-V_{in}$ turns off the converter.)
4. For normal 3.3V output, V_{o1} Trim pin should be left open.
5. Connect the 3.3V load (Load 1 in Figure 1) between $+V_{o1}$ and V_o RTN; connect the 1.8V/2.5V load (Load 2 in Figure 1) between $+V_{o2}$ and V_o RTN.
6. Connect the DVMs to the input and outputs.
7. Turn on the input power supply and check for the proper output voltages. V_{o1} should be $3.3V \pm 2\%$. V_{o2} should be $1.83V \pm 2\%$ if 1.8V V_o is selected (or V_{o2} should be $2.53V \pm 2\%$ if 2.5V V_o is selected).

QUICK START GUIDE FOR DEMONSTRATION CIRCUIT 448

DUAL OUTPUT ISOLATED POWER SUPPLY

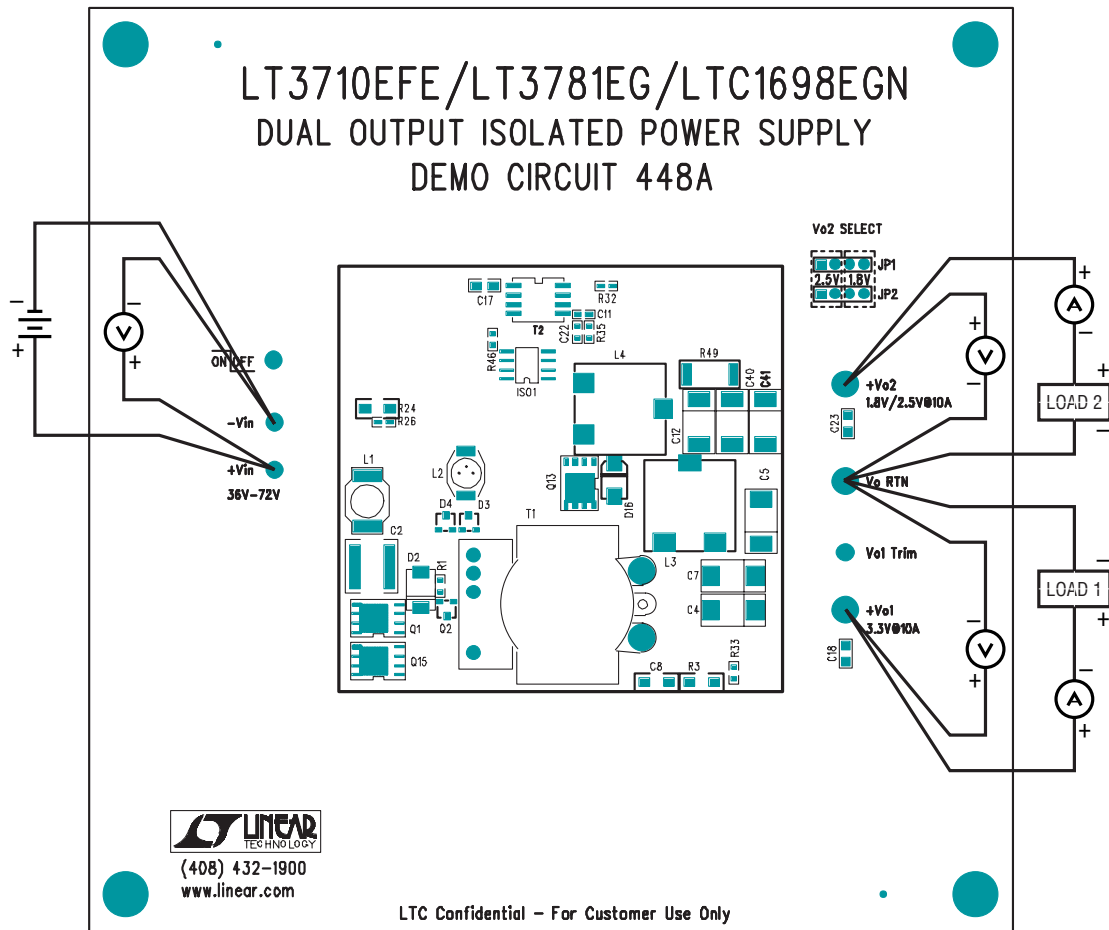

Figure 1. Proper Measurement Equipment Setup

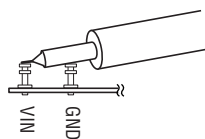

Figure 2. Measuring Input or Output Ripple

QUICK START GUIDE FOR DEMONSTRATION CIRCUIT 448

DUAL OUTPUT ISOLATED POWER SUPPLY

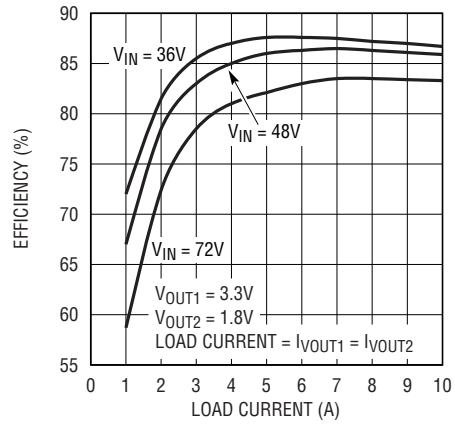

Figure 3. Efficiency vs load current: $V_{out1}=3.3V$ and $V_{out2}=1.8V$

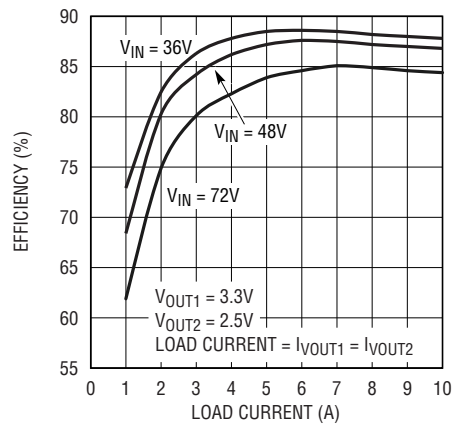
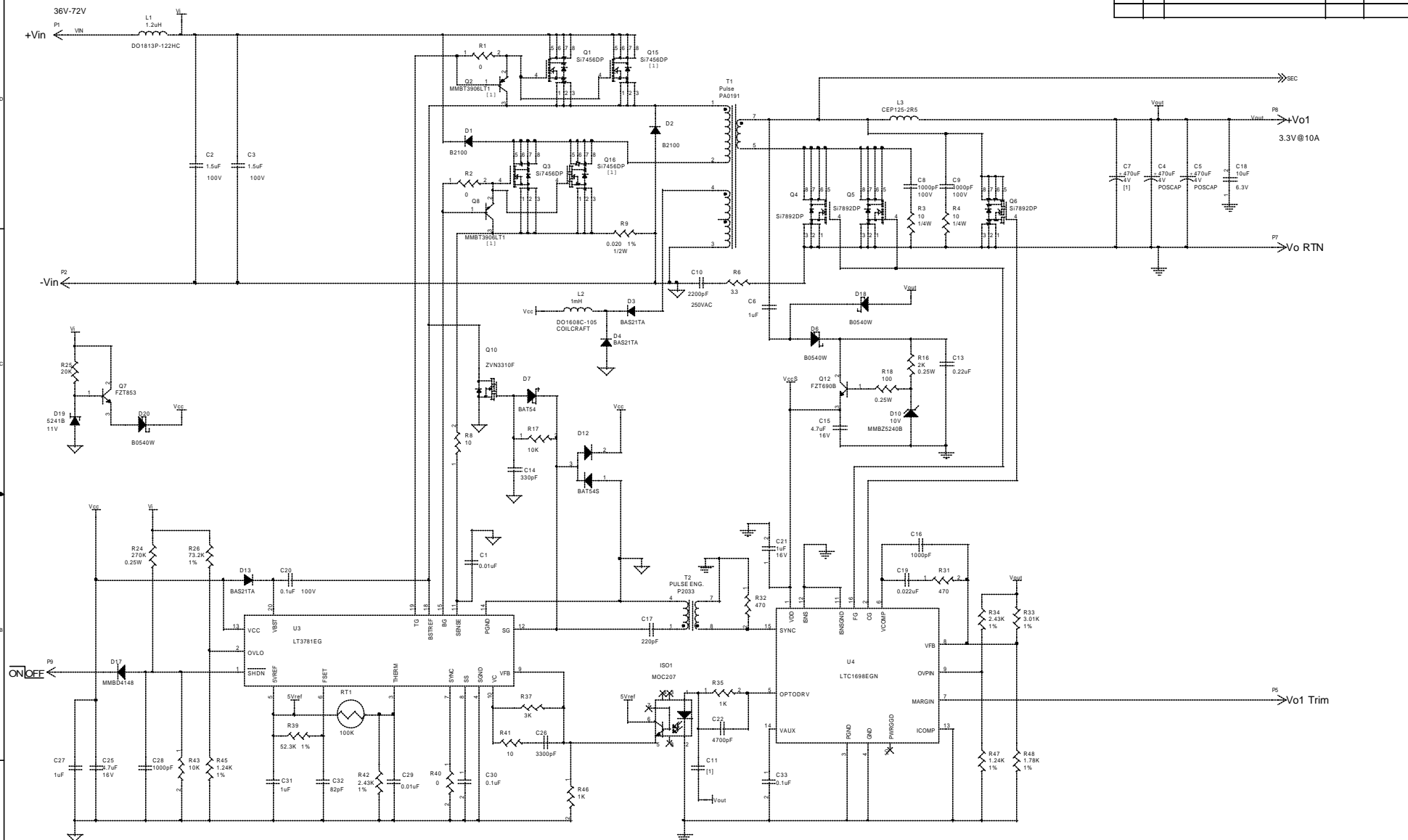

Figure 4. Efficiency vs load current: $V_{out1}=3.3V$ and $V_{out2}=2.5V$

ECO	REV	DESCRIPTION	DATE	APPROVED
0	5	PROTO	??	<



UNLESS OTHERWISE SPECIFIED DIMENSIONS ARE IN INCHES TOLERANCE ON ANGLE . . . 2 PLACES - . . . 3 PLACES - . . . INTERPRET DIM AND TOL PER ASME Y14.5M-1994	CONTRACT NO.		1630 McCarthy Blvd. Milpitas, CA 95028 Phone: (408) 434-2900 Fax: (408) 434-0207	
	APPROVALS	DATE		
THIRD ANGLE PROJECTION	CHECKED	TITLE	SCH. LT3710EFLT3781EGLT3781EGLT1698EGN DUAL OUTPUT ISOLATED POWER SUPPLY	
	APPROVED	SIZE	CAGE CODE	DWG NO
DO NOT SCALE DRAWING	Friday, October 25, 2002	SCALE NONE	FILENAME: 448A-5.DSN	SHEET 1 OF 2

REVISION HISTORY				
ECO	REV	DESCRIPTION	DATE	APPROVED
>	5	Proto	?	<

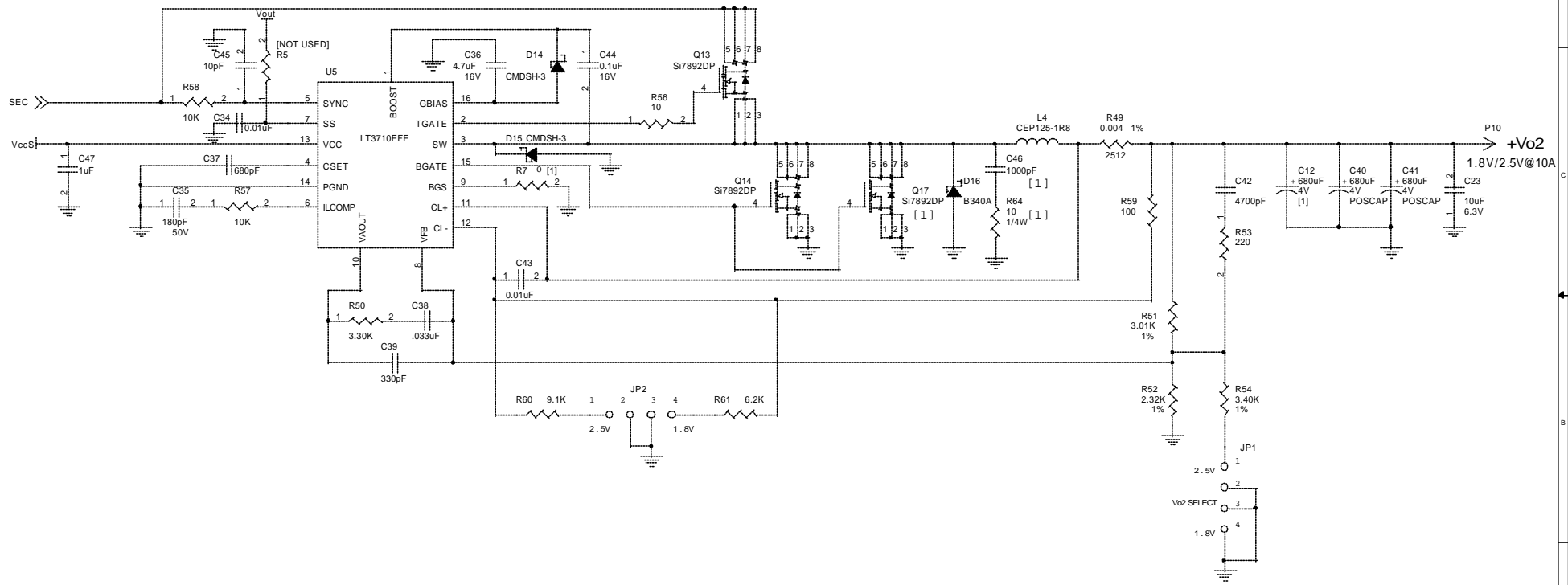

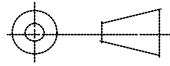
UNLESS OTHERWISE SPECIFIED DIMENSIONS ARE IN INCHES TOLERANCE ON ANGLE - - - 2 PLACES - - - 3 PLACES - - - INTERPRET DIM AND TOL PER ASME Y14.5M - 1994	CONTRACT NO.		 1630 McCarthy Blvd. Milpitas, CA 95035 Phone: (408)432-1900 Fax: (408)434-0507
	APPROVALS	DATE	
	DRAWN MEI	08-02-01	
	CHECKED		
THIRD ANGLE PROJECTION	APPROVED		TITLE SCH, LT3710EFE/LT3781EGL/TC1698EGN DUAL OUTPUT ISOLATED POWER SUPPLY
	ENGINEER		
	DESIGNER		SIZE B CAGE CODE DWG NO DC448A REV 5
DO NOT SCALE DRAWING	Friday, October 25, 2002	SCALE NONE	FILENAME 448A-5.PCB SHEET 2 OF 2