

TPS57114-EP 2.95-V to 6-V Input, 3.5-A Output, 2-MHz, Synchronous Step-Down SWIFT™ Converter

1 Features

- Two 12-mΩ (Typical) MOSFETs for High Efficiency at 3.5-A Loads
- 200-kHz to 2-MHz Switching Frequency
- 0.8-V ±1% Voltage Reference Over Temperature (–55°C to 125°C)
- Synchronizes to External Clock
- Adjustable Slow Start and Sequencing
- UV and OV Power-Good Output
- Thermally Enhanced 3-mm × 3-mm 16-Pin WQFN
- Supports Defense, Aerospace, and Medical Applications
 - Controlled Baseline
 - One Assembly and Test Site
 - One Fabrication Site
 - Available in Military (–55°C to 125°C) Temperature Range
 - Extended Product Life Cycle
 - Extended Product-Change Notification
 - Product Traceability

2 Applications

- Low-Voltage, High-Density Power Systems
- Point-of-Load Regulation for High-Performance DSPs, FPGAs, ASICs, and Microprocessors
- Broadband, Networking, and Optical Communications Infrastructure

4 Simplified Schematic

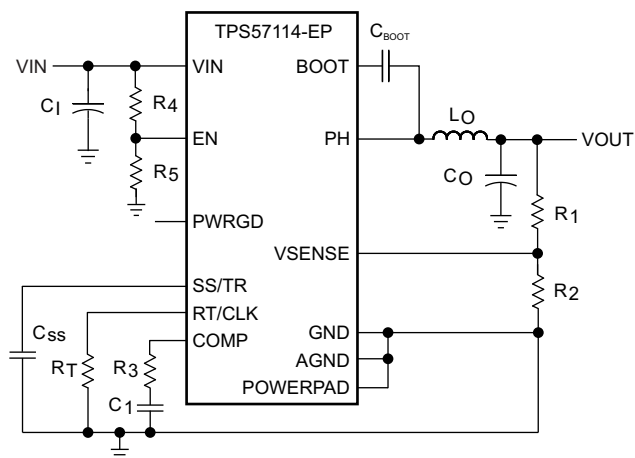

3 Description

The TPS57114-EP device is a full-featured 6-V, 3.5-A, synchronous step-down current-mode converter with two integrated MOSFETs.

The TPS57114-EP enables small designs by integrating the MOSFETs, implementing current-mode control to reduce external component count, reducing inductor size by enabling up to 2-MHz switching frequency, and minimizing the IC footprint with a small 3-mm × 3-mm thermally-enhanced WQFN package.

The TPS57114-EP provides accurate regulation for a variety of loads with an accurate ±1% voltage reference (VREF) over temperature.

The integrated 12-mΩ MOSFETs and 515-μA typical supply current maximize efficiency. Entering shutdown mode by using the enable pin reduces the shutdown supply current to 5.5 μA.

The internal undervoltage lockout (UVLO) setting is 2.45 V, but programming the threshold with a resistor network on the enable pin can increase it. The slow-start pin controls the output-voltage start-up ramp. An open-drain power-good signal indicates the output is within 93% to 107% of its nominal voltage.

Device Information⁽¹⁾

ORDER NUMBER	PACKAGE	BODY SIZE (NOM)
TPS57114MRTETEP	WQFN (16)	3.00 mm × 3.00 mm

(1) For all available packages, see the orderable addendum at the end of the data sheet.

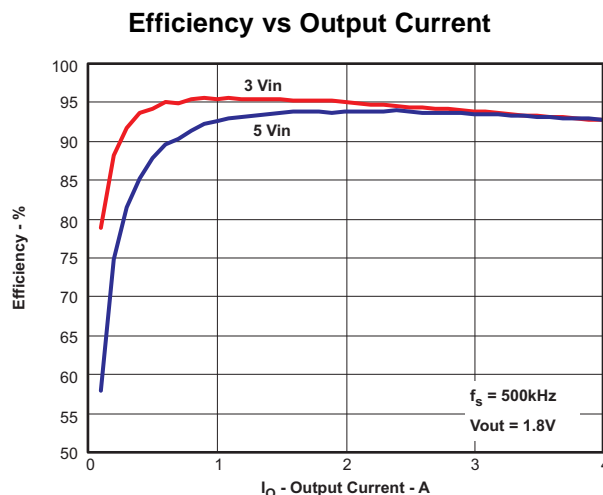

Table of Contents

1 Features	1	9.2 Functional Block Diagram	14
2 Applications	1	9.3 Feature Description	14
3 Description	1	9.4 Device Functional Modes	21
4 Simplified Schematic	1	10 Application and Implementation	23
5 Revision History	2	10.1 Application Information	23
6 Description (continued)	3	10.2 Typical Application	25
7 Pin Configuration and Functions	4	11 Power Supply Recommendations	33
8 Specifications	5	12 Layout	33
8.1 Absolute Maximum Ratings	5	12.1 Layout Guidelines	33
8.2 Handling Ratings	5	12.2 Layout Example	34
8.3 Recommended Operating Conditions	5	13 Device and Documentation Support	35
8.4 Thermal Information	6	13.1 Trademarks	35
8.5 Electrical Characteristics	6	13.2 Electrostatic Discharge Caution	35
8.6 Typical Characteristics	9	13.3 Glossary	35
9 Detailed Description	13	14 Mechanical, Packaging, and Orderable Information	35
9.1 Overview	13		

5 Revision History

Date	Revision	Notes
July 2014	*	Initial release.

6 Description (continued)

Frequency foldback and thermal shutdown protect the device during an overcurrent condition.

The SwitcherPro™ software tool, available at www.ti.com/switcherpro, supports the TPS57114-EP.

For more SWIFT™ documentation, see the TI website at www.ti.com/swift.

TPS57114-EP is a current mode controller used to support various topologies such as buck converter configuration.

Current mode control is a two-loop system. The switching power supply inductor is hidden within the inner current control loop. This simplifies the design of the outer voltage control loop and improves power supply performance in many ways, including better dynamics. The objective of this inner loop is to control the state-space averaged inductor current, but in practice, the instantaneous peak inductor current is the basis for control (switch current—equal to inductor current during the on time—is often sensed). If the inductor ripple current is small, peak inductor current control is nearly equivalent to average inductor current control.

The peak method of inductor current control functions by comparing the upslope of inductor current (or switch current) to a current program level set by the outer loop. The comparator turns the power switch off when the instantaneous current reaches the desired level. The current ramp is usually quite small compared to the programming level, especially when V_{IN} is low. As a result, this method is extremely susceptible to noise. A noise spike is generated each time the switch turns on. A fraction of a volt coupled into the control circuit can cause it to turn off immediately, resulting in a subharmonic operating mode with much greater ripple. Circuit layout and bypassing are critically important to successful operation.

The peak current mode control method is inherently unstable at duty ratios exceeding 0.5, resulting in subharmonic oscillation. A compensating ramp (with slope equal to the inductor current downslope) is usually applied to the comparator input to eliminate this instability. Slope compensation must be added to the sensed current waveform or subtracted from the control voltage to ensure stability above a 50% duty cycle. A compensating ramp (with slope equal to the inductor current downslope) is usually applied to the comparator input to eliminate this instability. Current limit control design has numerous advantages:

- Current mode control provided peak switch current limiting – pulse-by-pulse current limit.
- The control loop is simplified as one pole because the output inductor is pushed to higher frequency, thus a two-pole system turns into two real poles. Thus, the system reduces to a first-order system and simplifies the control.
- Multiple converters can be paralleled and allow equal current sharing amount the various converters.
- Inherently provides for input voltage feed-forward because any perturbation in the input voltage is reflected in the switch or inductor current. Because switch or inductor current is a direct-control input, this perturbation is rapidly corrected.
- The error amplifier output (outer control loop) defines the level at which the primary current (inner loop) regulates the pulse duration and output voltage.

7 Pin Configuration and Functions

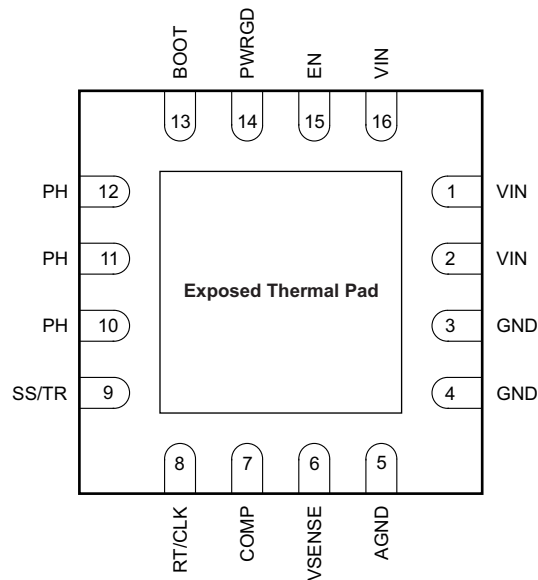

Pin Functions

PIN		DESCRIPTION
NAME	NO.	
AGND	5	Connect analog ground electrically to GND close to the device.
BOOT	13	The device requires a bootstrap capacitor between BOOT and PH. Having the voltage on this capacitor below the minimum required by the BOOT UVLO forces the output to switch off until the capacitor recharges.
COMP	7	Error amplifier output, and input to the output-switch current comparator. Connect frequency-compensation components to this pin.
EN	15	Enable pin, internal pullup current source. Pull below 1.2 V to disable. Float to enable. An alternative use of this pin can be to set the on-off threshold (adjust UVLO) with two additional resistors.
GND	3	Power ground. Electrically connect this pin directly to the thermal pad under the IC.
	4	
PH	10	The source of the internal high-side power MOSFET and the drain of the internal low-side (synchronous) rectifier MOSFET
	11	
	12	
PWRGD	14	An open-drain output; asserts low if output voltage is low due to thermal shutdown, overcurrent, overvoltage, undervoltage, or EN shutdown.
RT/CLK	8	Resistor-timing or external-clock input pin.
SS/TR	9	Slow start and tracking. An external capacitor connected to this pin sets the output-voltage rise time. Another use of this pin is for tracking.
VIN	1	Input supply voltage, 2.95 to 6 V
	2	
	16	
VSENSE	6	Inverting node of the transconductance (gm) error amplifier
Thermal pad	—	Connect the GND pin to the exposed thermal pad for proper operation. Connect this thermal pad to any internal PCB ground plane using multiple vias for good thermal performance.

8 Specifications

8.1 Absolute Maximum Ratings⁽¹⁾

		MIN	MAX	UNIT
Input voltage	VIN	-0.3	7	V
	EN	-0.3	7	
	BOOT		PH + 7	
	VSENSE	-0.3	3	
	COMP	-0.3	3	
	PWRGD	-0.3	7	
	SS/TR	-0.3	3	
	RT/CLK	-0.3	7	
Output voltage	BOOT-PH		7	V
	PH	-0.6	7	
	PH 10-ns transient	-2	10	
Source current	EN		100	μA
	RT/CLK		100	μA
Sink current	COMP		100	μA
	PWRGD		10	mA
	SS/TR		100	μA
Temperature	T _J	-55	150	°C

- (1) Stresses beyond those listed under *Absolute Maximum Ratings* may cause permanent damage to the device. These are stress ratings only, which do not imply functional operation of the device at these or any other conditions beyond those indicated under *Recommended Operating Conditions*. Exposure to absolute-maximum-rated conditions for extended periods may affect device reliability.

8.2 Handling Ratings

		MIN	MAX	UNIT	
T _{stg}	Storage temperature range	-65	150	°C	
V _(ESD)	Electrostatic discharge	Human body model (HBM), per ANSI/ESDA/JEDEC JS-001, all pins ⁽¹⁾	-4000	4000	V
		Machine model (MM)	-200	200	
		Charged device model (CDM), per JEDEC specification JESD22-C101, all pins ⁽²⁾	-1500	1500	

- (1) JEDEC document JEP155 states that 500-V HBM allows safe manufacturing with a standard ESD control process.

- (2) JEDEC document JEP157 states that 250-V CDM allows safe manufacturing with a standard ESD control process.

8.3 Recommended Operating Conditions

over operating free-air temperature range (unless otherwise noted)

		MIN	NOM	MAX	UNIT
V _(VIN)	Input voltage	2.95		6	V
T _A	Operating ambient temperature	-55		125	°C
T _J	Operating junction temperature	-55		150	°C

8.4 Thermal Information

THERMAL METRIC ⁽¹⁾		TPS57114-EP		UNIT
		RTE		
		16 PINS		
$R_{\theta JA}$	Junction-to-ambient thermal resistance ⁽²⁾	44.4		°C/W
$R_{\theta JC(top)}$	Junction-to-case (top) thermal resistance ⁽³⁾	46.1		
$R_{\theta JB}$	Junction-to-board thermal resistance ⁽⁴⁾	16		
Ψ_{JT}	Junction-to-top characterization parameter ⁽⁵⁾	0.7		
Ψ_{JB}	Junction-to-board characterization parameter ⁽⁶⁾	16.9		
$R_{\theta JC(bot)}$	Junction-to-case (bottom) thermal resistance ⁽⁷⁾	4.6		

- (1) For more information about traditional and new thermal metrics, see the *IC Package Thermal Metrics* application report, [SPRA953](#).
- (2) The junction-to-ambient thermal resistance under natural convection is obtained in a simulation on a JEDEC-standard, high-K board, as specified in JESD51-7, in an environment described in JESD51-2a.
- (3) The junction-to-case (top) thermal resistance is obtained by simulating a cold plate test on the package top. No specific JEDEC-standard test exists, but a close description can be found in the ANSI SEMI standard G30-88.
- (4) The junction-to-board thermal resistance is obtained by simulating in an environment with a ring cold plate fixture to control the PCB temperature, as described in JESD51-8.
- (5) The junction-to-top characterization parameter, Ψ_{JT} , estimates the junction temperature of a device in a real system and is extracted from the simulation data for obtaining θ_{JA} , using a procedure described in JESD51-2a (sections 6 and 7).
- (6) The junction-to-board characterization parameter, Ψ_{JB} , estimates the junction temperature of a device in a real system and is extracted from the simulation data for obtaining θ_{JA} , using a procedure described in JESD51-2a (sections 6 and 7).
- (7) The junction-to-case (bottom) thermal resistance is obtained by simulating a cold plate test on the exposed (power) pad. No specific JEDEC standard test exists, but a close description can be found in the ANSI SEMI standard G30-88.

8.5 Electrical Characteristics

 $T_J = -55^{\circ}\text{C}$ to 150°C , $V_{IN} = 2.95$ to 6 V (unless otherwise noted)

PARAMETER	TEST CONDITIONS	MIN	TYP	MAX	UNIT
SUPPLY VOLTAGE (VIN PIN)					
Internal undervoltage-lockout threshold	VIN UVLO START		2.28	2.5	V
	VIN UVLO STOP		2.45	2.6	V
Shutdown supply current	$V_{(EN)} = 0$ V, 2.95 V $\leq V_{(VIN)} \leq 6$ V		5.5	15	μA
Quiescent current – I_q	$V_{(VSENSE)} = 0.9$ V, $V_{(VIN)} = 5$ V, $RT = 400$ k Ω		515	750	μA
ENABLE AND UVLO (EN PIN)					
Enable threshold	Rising		1.25		V
	Falling		1.18		
Input current	Enable threshold + 50 mV		-3.2		μA
	Enable threshold – 50 mV		-1.65		
VOLTAGE REFERENCE (VSENSE PIN)					
Voltage reference	2.95 V $\leq V_{(VIN)} \leq 6$ V, $-55^{\circ}\text{C} < T_J < 150^{\circ}\text{C}$	0.79	0.8	0.81	V
MOSFET					
High-side switch resistance	BOOT-PH = 5 V		12	30	m Ω
	BOOT-PH = 2.95 V		16	30	
Low-side switch resistance	$V_{(VIN)} = 5$ V		13	30	m Ω
	$V_{(VIN)} = 2.95$ V		17	30	
ERROR AMPLIFIER					
Input current			2		nA
Error-amplifier transconductance (gm)	-2 $\mu\text{A} < I_{(COMP)} < 2$ μA , $V_{(COMP)} = 1$ V		245		μS
Error-amplifier transconductance (gm) during slow start	-2 $\mu\text{A} < I_{(COMP)} < 2$ μA , $V_{(COMP)} = 1$ V, $V_{(VSENSE)} = 0.4$ V		79		μS
Error-amplifier source and sink	$V_{(COMP)} = 1$ V, 100-mV overdrive		± 20		μA
COMP to Iswitch gm			25		S

Electrical Characteristics (continued)
 $T_J = -55^\circ\text{C}$ to 150°C , $V_{IN} = 2.95$ to 6 V (unless otherwise noted)

PARAMETER	TEST CONDITIONS	MIN	TYP	MAX	UNIT
CURRENT LIMIT					
Current-limit threshold	$V_{(VIN)} = 2.95$ V, $25^\circ\text{C} < T_J < 150^\circ\text{C}$	5	6.4		A
	$T_J = -55^\circ\text{C}$	4			
	$V_{(VIN)} = 6$ V, $25^\circ\text{C} < T_J < 150^\circ\text{C}$	4.4	5.56		
	$T_J = -55^\circ\text{C}$	4			
THERMAL SHUTDOWN					
Thermal shutdown			168		$^\circ\text{C}$
Hysteresis			20		$^\circ\text{C}$
TIMING RESISTOR AND EXTERNAL CLOCK (RT/CLK PIN)					
Switching frequency range using RT mode		200		2000	kHz
Switching frequency	$R_{(RT/CLK)} = 400$ k Ω	400	500	600	kHz
Switching frequency range using CLK mode		300		2000	kHz
Minimum CLK pulse duration		80			ns
RT/CLK voltage	$R_{(RT/CLK)} = 400$ k Ω		0.5		V
RT/CLK high threshold			1.6	2.5	V
RT/CLK low threshold		0.4	0.6		V
RT/CLK falling edge to PH rising edge delay	Measure at 500 kHz with RT resistor in series		90		ns
PLL lock in time	Measure at 500 kHz		42		μs
PH (PH PIN)					
Minimum on-time	Measured at 50% points on PH, $I_{OUT} = 3.5$ A		75		ns
	Measured at 50% points on PH, $V_{(VIN)} = 6$ V, $I_{OUT} = 0$ A		120		
Minimum off-time	Prior to skipping off pulses, BOOT-PH = 2.95 V, $I_{OUT} = 3.5$ A		60		ns
Rise time	$V_{(VIN)} = 6$ V, 3.5 A		2.25		V/ns
Fall time			2		
BOOT (BOOT PIN)					
BOOT charge resistance	$V_{(VIN)} = 5$ V		16		Ω
BOOT-PH UVLO	$V_{(VIN)} = 2.95$ V		2.1		V
SLOW START AND TRACKING (SS/TR PIN)					
Charge current	$V_{(SS/TR)} = 0.4$ V		2		μA
SS/TR to VSENSE matching	$V_{(SS/TR)} = 0.4$ V		54		mV
SS/TR to reference crossover	98% normal		1.1		V
SS/TR discharge voltage (overload)	$V_{(VSENSE)} = 0$ V		60		mV
SS/TR discharge current (overload)	$V_{(VSENSE)} = 0$ V, $V_{(SS/TR)} = 0.4$ V		350		μA
SS discharge current (UVLO, EN, thermal fault)	$V_{(VIN)} = 5$ V, $V_{(SS)} = 0.5$ V		1.9		mA
POWER-GOOD (PWRGD PIN)					
VSENSE threshold	$V_{(VSENSE)}$ falling (fault)		91		% $V_{(VREF)}$
	$V_{(VSENSE)}$ rising (good)		93		
	$V_{(VSENSE)}$ rising (fault)		109		
	$V_{(VSENSE)}$ falling (good)		107		
Hysteresis	$V_{(VSENSE)}$ falling		2		% $V_{(VREF)}$
Output high leakage	$V_{(VSENSE)} = V_{(VREF)}$, $V_{(PWRGD)} = 5.5$ V		7		nA
On-resistance			56	100	Ω
Output low	$I_{(PWRGD)} = 3$ mA		0.3		V
Minimum VIN for valid output	$V_{(PWRGD)} < 0.5$ V at 100 μA		0.650	1.5	V

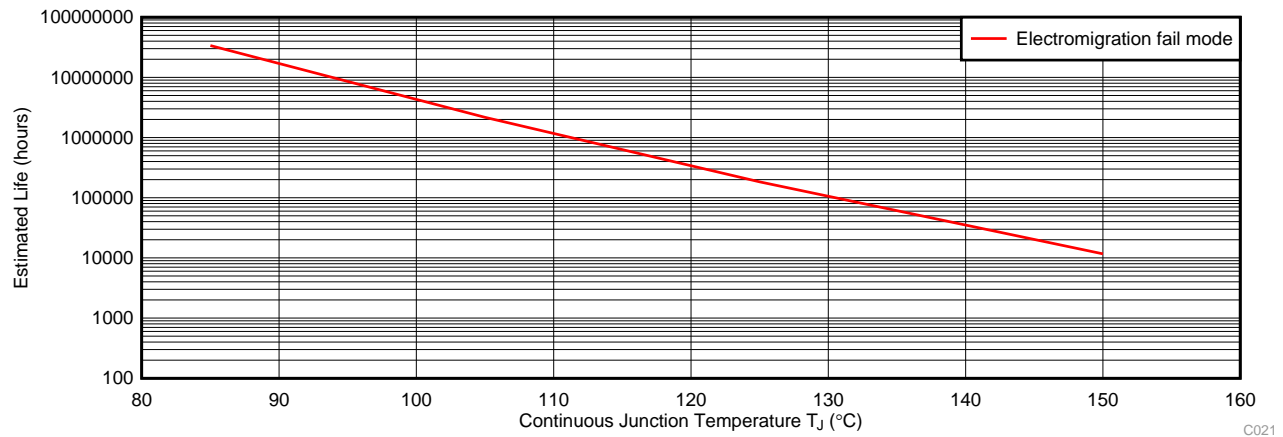

C021

- (1) See data sheet for absolute maximum and minimum recommended operating conditions.
- (2) Silicon operating life design goal is 10 years at 105°C junction temperature (does not include package interconnect life).
- (3) Enhanced plastic product disclaimer applies.

Figure 1. TPS57114-EP Derating Chart

8.6 Typical Characteristics

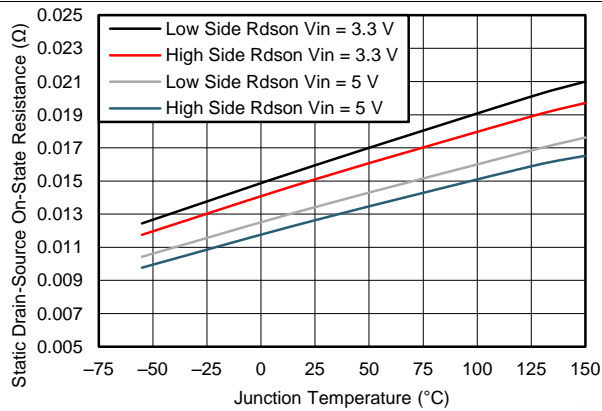

Figure 2. High-Side and Low-Side $r_{ds(on)}$ vs Temperature

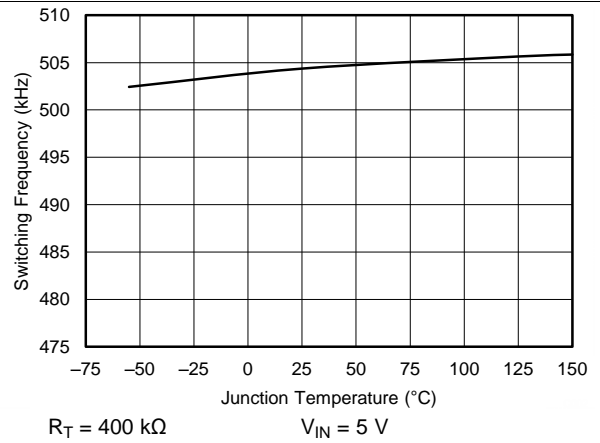

Figure 3. Frequency vs Temperature

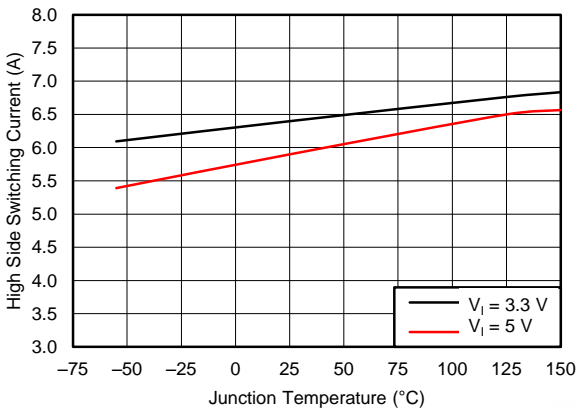

Figure 4. High-Side Current Limit vs Temperature

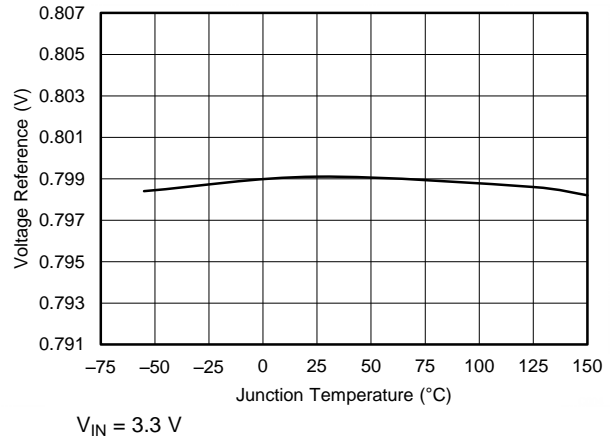

Figure 5. Voltage Reference vs Temperature

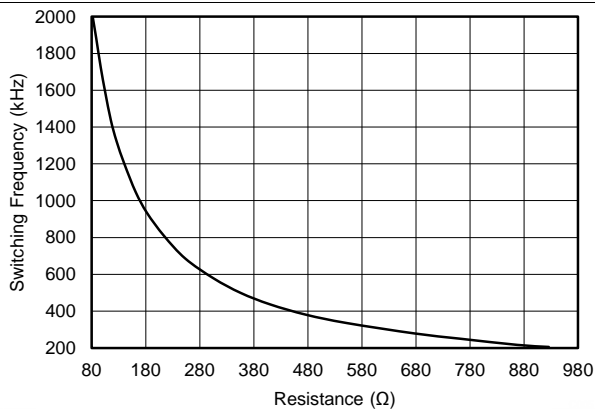

Figure 6. Switching Frequency vs R_T Resistance, Low-Frequency Range

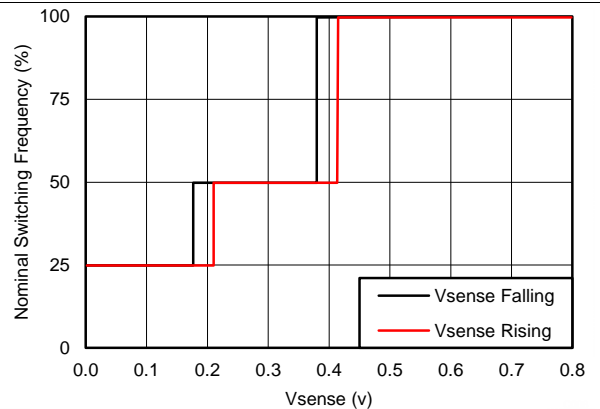

Figure 7. Switching Frequency vs V_{SENSE}

Typical Characteristics (continued)

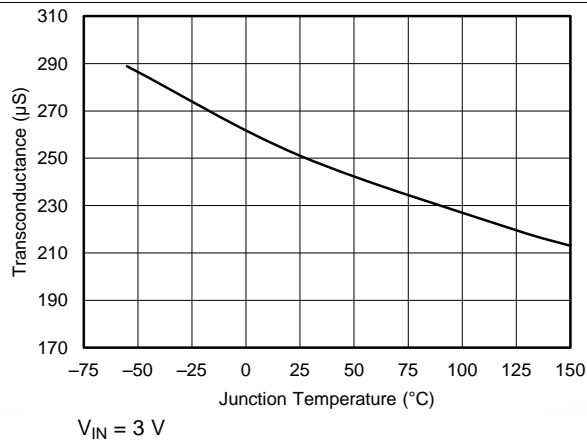

Figure 8. Transconductance vs Temperature

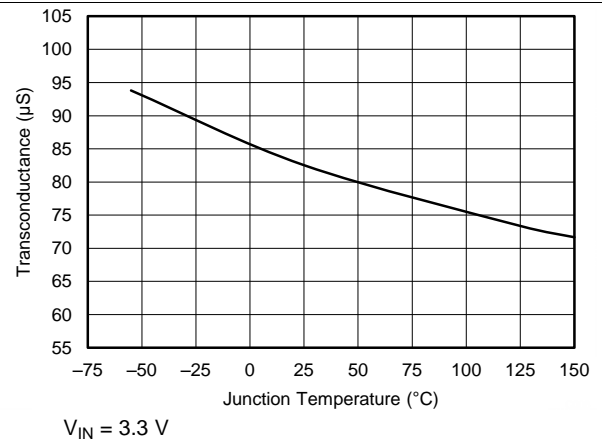

Figure 9. Transconductance (Slow Start) vs Junction Temperature

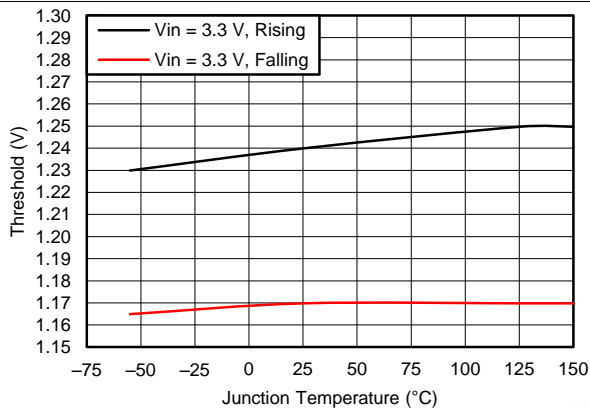

Figure 10. EN Pin Voltage vs Temperature

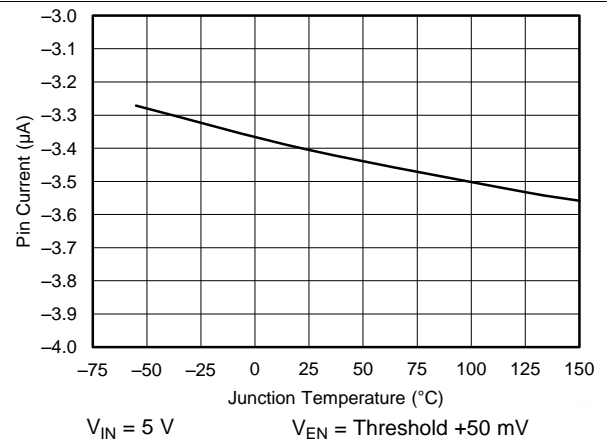

Figure 11. EN Pin Current vs Temperature

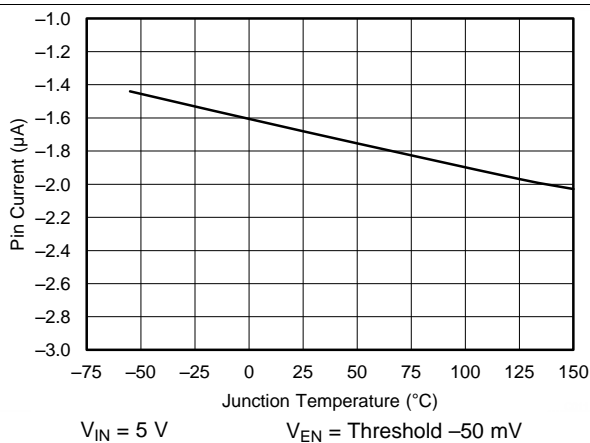

Figure 12. EN Pin Current vs Temperature

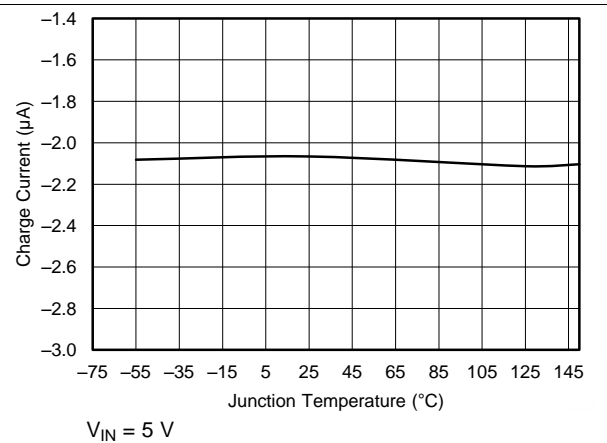

Figure 13. Charge Current vs Temperature

Typical Characteristics (continued)

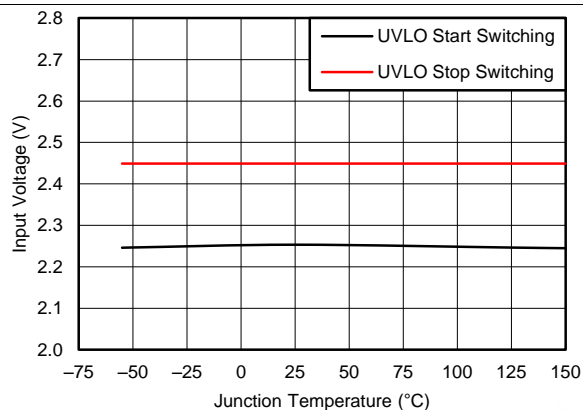
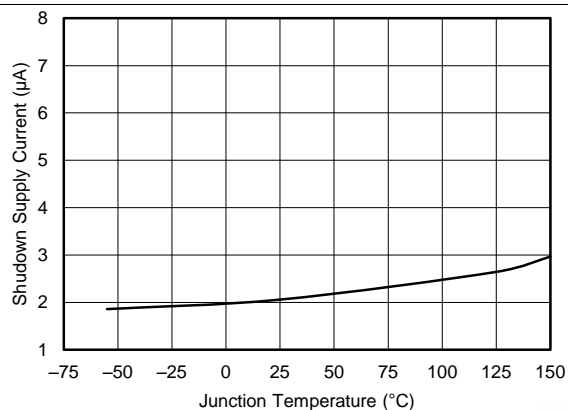
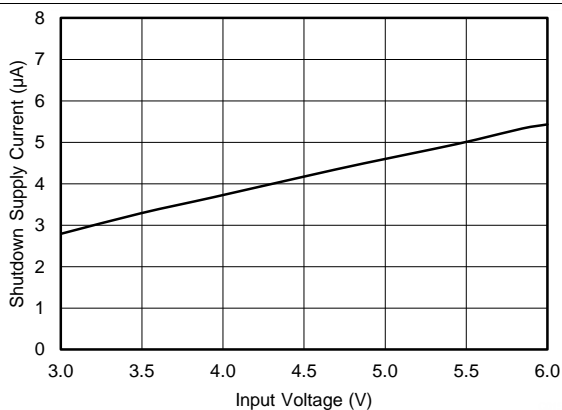

Figure 14. Input Voltage vs Temperature



$V_{IN} = 3.3\text{ V}$

Figure 15. Shutdown Supply Current vs Temperature



$T_J = 25^\circ\text{C}$

Figure 16. Shutdown Supply Current vs Input Voltage

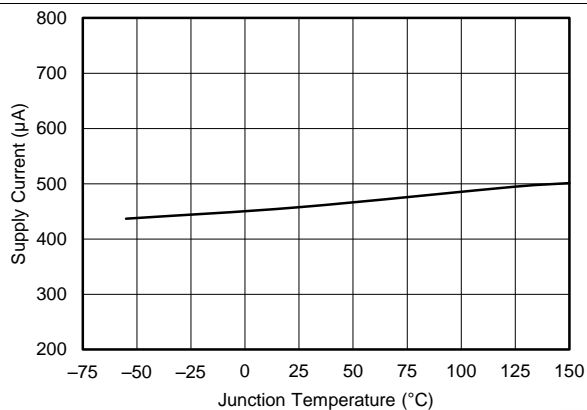

$V_{IN} = 3.3\text{ V}$

Figure 17. VIN Supply Current vs Junction Temperature

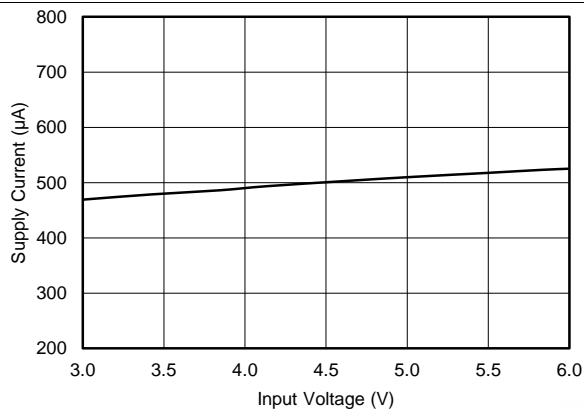

$T_J = 25^\circ\text{C}$

Figure 18. VIN Supply Current vs Input Voltage

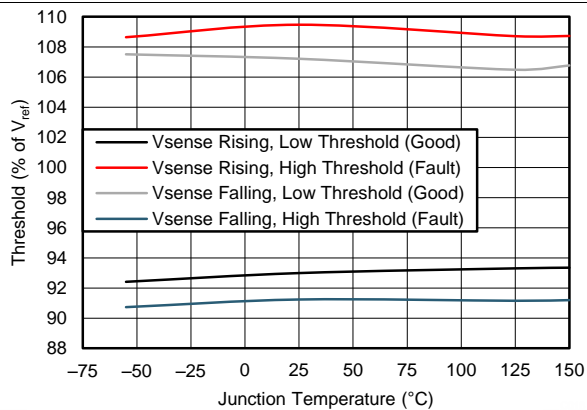
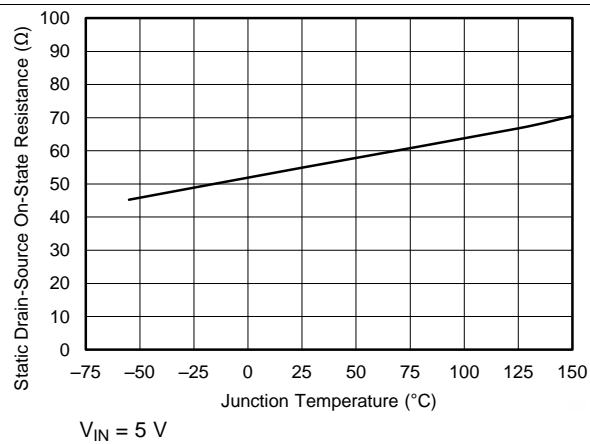
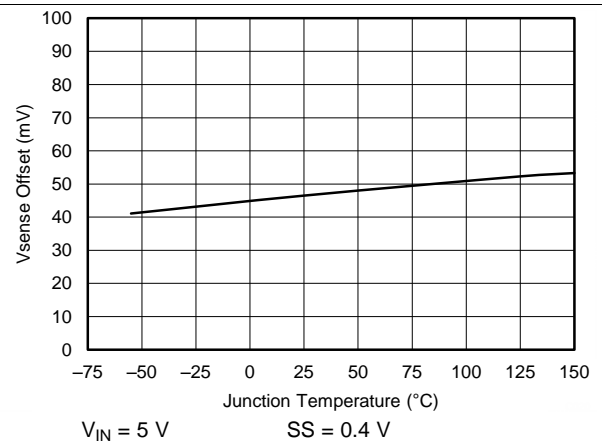

Figure 19. PWRGD Threshold vs Temperature

Typical Characteristics (continued)

Figure 20. PWRGD On-Resistance vs Temperature

Figure 21. SS/TR to VSENSE Offset vs Temperature

9 Detailed Description

9.1 Overview

The TPS57114-EP is a 6-V, 3.5-A, synchronous step-down (buck) converter with two integrated N-channel MOSFETs. To improve performance during line and load transients, the device implements a constant-frequency, peak-current mode control which reduces output capacitance and simplifies external frequency-compensation design. The wide switching-frequency range of 200 to 2000 kHz allows for efficiency and size optimization when selecting the output-filter components. Adjust the switching frequency using a resistor to ground on the RT/CLK pin. The device has an internal phase-lock loop (PLL) on the RT/CLK pin that synchronizes the power-switch turn-on to the falling edge of an external system clock.

The TPS57114-EP has a typical default start-up voltage of 2.45 V. The EN pin has an internal pullup current source; to adjust the input-voltage UVLO, use two external resistors on the EN pin. In addition, the pullup current provides a default condition, allowing the device to operate when the EN pin is floating. The total operating current for the TPS57114-EP is typically 515 μ A when not switching and under no load. When the device is disabled, the supply current is less than 5.5 μ A.

The integrated 12-m Ω MOSFETs allow for high-efficiency power-supply designs with continuous output currents up to 3.5 A.

The TPS57114-EP reduces the external component count by integrating the boot recharge diode. A capacitor between the BOOT and PH pins supplies the bias voltage for the integrated high-side MOSFET. A UVLO circuit, which monitors the boot-capacitor voltage, turns off the high-side MOSFET when the voltage falls below a preset threshold. This BOOT circuit allows the TPS57114-EP to operate approaching 100% duty cycle. The output voltage can be stepped down to as low as the 0.8-V reference.

The TPS57114-EP has a power-good comparator (PWRGD) with 2% hysteresis.

The TPS57114-EP minimizes excessive output overvoltage transients by taking advantage of the overvoltage power-good comparator. The regulated output voltage exceeding 109% of the nominal voltage activates the overvoltage comparator, which turns off the high-side MOSFET and masks it from turning on until the output voltage is lower than 107% of the nominal voltage.

The SS/TR (slow-start or tracking) pin minimizes inrush currents or provides power-supply sequencing during power-up. Connect a small-value capacitor to the pin for slow start. Discharging the SS/TR pin before the output powers up ensures a repeatable restart after an overtemperature fault, UVLO fault, or disabled condition.

The use of a frequency-foldback circuit reduces the switching frequency during start-up and overcurrent fault conditions to help limit the inductor current.

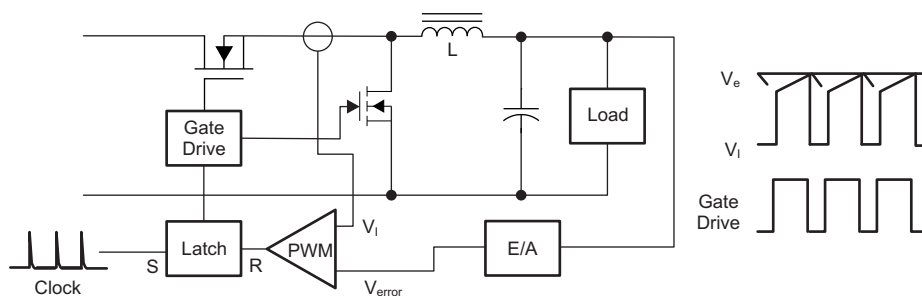
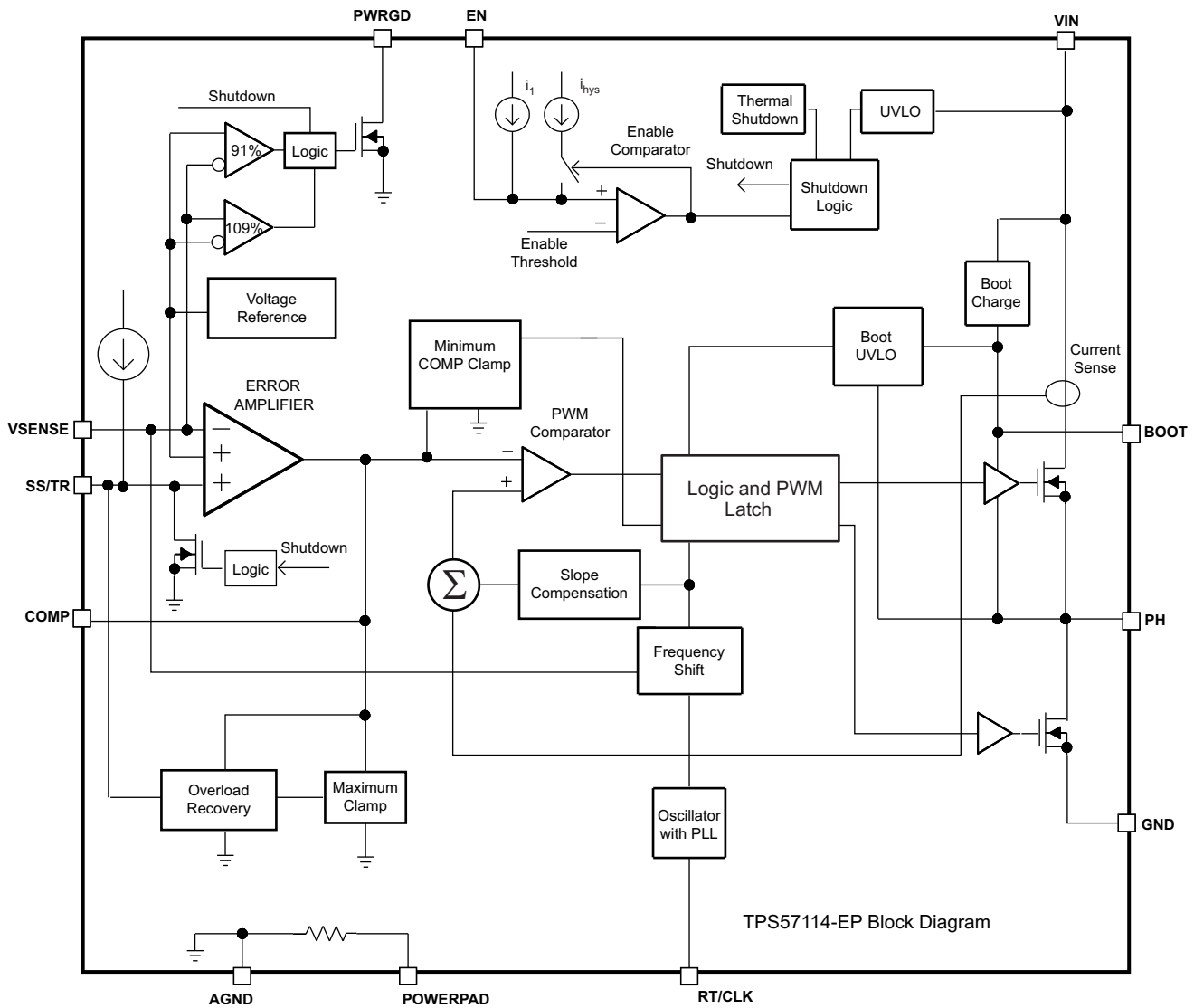

Figure 22. Peak Current Mode Control (See Application Note [U-140](#))

9.2 Functional Block Diagram



9.3 Feature Description

9.3.1 Fixed-Frequency Pwm Control

The TPS57114-EP uses an adjustable fixed-frequency peak-current mode control. An error amplifier, which drives the COMP pin, compares the output voltage through external resistors on the VSENSE pin to an internal voltage reference. An internal oscillator initiates the turn-on of the high-side power switch. The device compares the error-amplifier output to the high-side power-switch current. When the power-switch current reaches the COMP pin voltage level, the high-side power switch turns off and the low-side power switch turns on. The COMP pin voltage increases and decreases as the output current increases and decreases. The device implements a current limit by clamping the COMP pin voltage to a maximum level, and also implements a minimum clamp for improved transient-response performance.

9.3.2 Slope Compensation and Output Current

The TPS57114-EP adds a compensating ramp to the switch-current signal. This slope compensation prevents subharmonic oscillations as the duty cycle increases. The available peak inductor current remains constant over the full duty-cycle range.

Feature Description (continued)

9.3.3 Bootstrap Voltage (Boot) and Low-Dropout Operation

The TPS57114-EP has an integrated boot regulator and requires a small ceramic capacitor between the BOOT and PH pins to provide the gate-drive voltage for the high-side MOSFET. The value of the ceramic capacitor should be 0.1 μ F. TI recommends a ceramic capacitor with an X7R or X5R grade dielectric and a voltage rating of 10 V or higher because of the stable characteristics over temperature and voltage.

To improve dropout, the design of the TPS57114-EP is for operation at 100% duty cycle as long as the BOOT-to-PH pin voltage is greater than 2.2 V. A UVLO circuit turns off the high-side MOSFET, allowing for the low-side MOSFET to conduct when the voltage from BOOT to PH drops below 2.2 V. Because the supply current sourced from the BOOT pin is low, the high-side MOSFET can remain on for more switching cycles than are required to refresh the capacitor; thus, the effective duty cycle of the switching regulator is high.

9.3.4 Error Amplifier

The TPS57114-EP has a transconductance amplifier which it uses as an error amplifier. The error amplifier compares the VSENSE voltage to the lower of the SS/TR pin voltage or the internal 0.8-V voltage reference. The transconductance of the error amplifier is 245 μ S during normal operation. When the voltage of the VSENSE pin is below 0.8 V and the device is regulating using the SS/TR voltage, the gm is typically greater than 79 μ S, but less than 245 μ S.

9.3.5 Voltage Reference

The voltage-reference system produces a precise $\pm 1\%$ voltage reference over temperature by scaling the output of a temperature-stable band-gap circuit. The band-gap and scaling circuits produce 0.8 V at the non-inverting input of the error amplifier.

9.3.6 Adjusting the Output Voltage

A resistor divider from the output node to the VSENSE pin sets the output voltage. TI recommends using divider resistors with 1% tolerance or better. Start with 100 k Ω for the R1 resistor and use Equation 1 to calculate R2. To improve efficiency at light loads, consider using larger-value resistors. If the values are too high, the regulator is more susceptible to noise, and voltage errors from the VSENSE input current are noticeable.

$$R2 = R1 \times \left(\frac{0.799 \text{ V}}{V_O - 0.799 \text{ V}} \right) \quad (1)$$

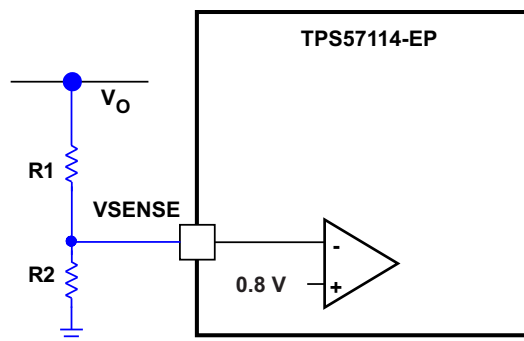

Figure 23. Voltage-Divider Circuit

Feature Description (continued)

9.3.7 Enable Functionality and Adjusting UVLO

The VIN pin voltage falling below 2.6 V disables the TPS57114-EP. If an application requires a higher UVLO, use the EN pin as shown in Figure 24 to adjust the input voltage UVLO by connecting two external resistors. TI recommends using the EN resistors to set the UVLO falling threshold (V_{STOP}) above 2.6 V. Set the rising threshold (V_{START}) to provide enough hysteresis to allow for any input supply variations. The EN pin has an internal pullup current source that provides the default condition of the TPS57114-EP operating when the EN pin floats. When the EN pin voltage exceeds 1.25 V, the circuitry adds an additional 1.6 μ A of hysteresis. Pulling the EN pin below 1.18 V removes the 1.6 μ A. This additional current facilitates input voltage hysteresis.

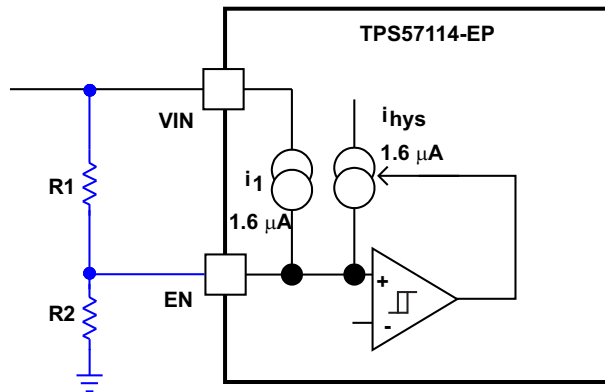

Figure 24. Adjustable UVLO

$$R1 = \frac{V_{START} \left(\frac{V_{ENFALLING}}{V_{ENRISING}} \right) - V_{STOP}}{I_1 \left(1 - \frac{V_{ENFALLING}}{V_{ENRISING}} \right) + I_{hys}} \quad (2)$$

$$R2 = \frac{R1 \times V_{ENFALLING}}{V_{STOP} - V_{ENFALLING} + R1(I_1 + I_{hys})} \quad (3)$$

where

- $I_{hys} = 1.6 \mu A$
- $I_1 = 1.6 \mu A$
- $V_{ENRISING} = 1.25 V$
- $V_{ENFALLING} = 1.18 V$

9.3.8 Slow-Start or Tracking Pin

The TPS57114-EP regulates to the lower of the SS/TR pin and the internal reference voltage. A capacitor on the SS/TR pin to ground implements a slow-start time. The TPS57114-EP has an internal pullup current source of 2 μ A which charges the external slow-start capacitor. Equation 4 calculates the required slow-start capacitor value.

$$C_{SS}(nF) = \frac{T_{SS}(mS) \times I_{SS}(\mu A)}{V_{REF}(V)}$$

where

- T_{SS} is the desired slow-start time in ms
- I_{SS} is the internal slow-start charging current of 2 μ A
- V_{REF} is the internal voltage reference of 0.8 V

(4)

Feature Description (continued)

If during normal operation VIN goes below UVLO, the EN pin goes below 1.2 V, or a thermal shutdown event occurs, the TPS57114-EP stops switching. Upon VIN going above UVLO, the release or pulling high of EN, or the exit of a thermal shutdown, SS/TR discharges to below 60 mV before reinitiating a powering-up sequence. The VSENSE voltage follows the SS/TR pin voltage with a 54-mV offset up to 85% of the internal voltage reference. When the SS/TR voltage is greater than 85% on the internal reference voltage, the offset increases as the effective system reference transitions from the SS/TR voltage to the internal voltage reference.

9.3.9 Constant Switching Frequency and Timing Resistor (RT/CLK Pin)

The switching frequency of the TPS57114-EP is adjustable over a wide range from 300 to 2000 kHz by placing a maximum of 700 kΩ or minimum of 85 kΩ, respectively, on the RT/CLK pin. An internal amplifier holds this pin at a fixed voltage when using an external resistor to ground to set the switching frequency. The RT/CLK is typically 0.5 V. To determine the timing resistance for a given switching frequency, use the curve in [Figure 6](#) or [Equation 5](#).

$$RT(k\Omega) = \frac{235892}{f_{sw}(kHz)^{1.027}} \quad (5)$$

$$f_{sw}(kHz) = \frac{171032}{RT(k\Omega)^{0.974}} \quad (6)$$

To reduce the solution size, one would typically set the switching frequency as high as possible, but consider tradeoffs of the efficiency, maximum input voltage, and minimum controllable on-time.

The minimum controllable on-time is typically 65 ns at full-current load and 120 ns at no load and limits the maximum operating input voltage or output voltage.

9.3.10 Overcurrent Protection

The TPS57114-EP implements a cycle-by-cycle current limit. During each switching cycle, the device compares the high-side switch current to the voltage on the COMP pin. When the instantaneous switch current intersects the COMP voltage, the high-side switch turns off. During overcurrent conditions that pull the output voltage low, the error amplifier responds by driving the COMP pin high, increasing the switch current. There is an internal clamp on the error-amplifier output. This clamp functions as a switch-current limit.

9.3.11 Frequency Shift

To operate at high switching frequencies and provide protection during overcurrent conditions, the TPS57114-EP implements a frequency shift. Without this frequency shift, during an overcurrent condition the low-side MOSFET may not turn off long enough to reduce the current in the inductor, causing a current runaway. With frequency shift, during an overcurrent condition there is a switching frequency reduction from 100% to 50%, then 25%, as the voltage decreases from 0.8 to 0 V on the VSENSE pin, to allow the low-side MOSFET to be off long enough to decrease the current in the inductor. During start-up, the switching frequency increases as the voltage on VSENSE increases from 0 to 0.8 V. See [Figure 7](#) for details.

9.3.12 Reverse Overcurrent Protection

The TPS57114-EP implements low-side current protection by detecting the voltage across the low-side MOSFET. When the converter sinks current through its low-side FET, the control circuit turns off the low-side MOSFET if the reverse current is typically more than 4.5 A. By implementing this additional protection scheme, the converter is able to protect itself from excessive current during power cycling and start-up into prebiased outputs.

Feature Description (continued)

9.3.13 Synchronize Using the RT/CLK Pin

The RT/CLK pin synchronizes the converter to an external system clock (see [Figure 25](#)). To implement the synchronization feature in a system, connect a square wave to the RT/CLK pin with an on-time of at least 75 ns. If the pin goes above the PLL upper threshold, a mode change occurs, and the pin becomes a synchronization input. The device disables the internal amplifier, and the pin is a high-impedance clock input to the internal PLL. If clocking edges stop, the device re-enables the internal amplifier and the mode returns to the frequency set by the resistor. The square-wave amplitude at this pin must transition lower than 0.6 V and higher than 1.6 V, typically. The synchronization frequency range is 300 to 2000 kHz. The rising edge of PH synchronizes to the falling edge of the RT/CLK pin.

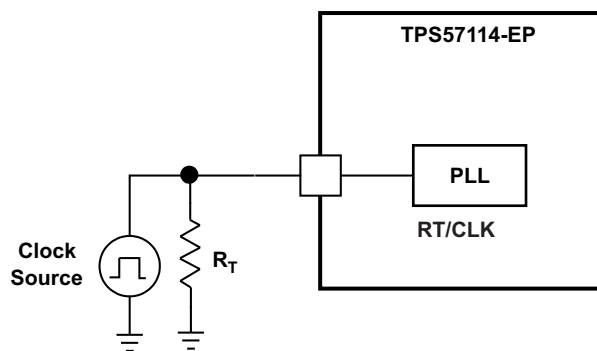

Figure 25. Synchronizing to a System Clock

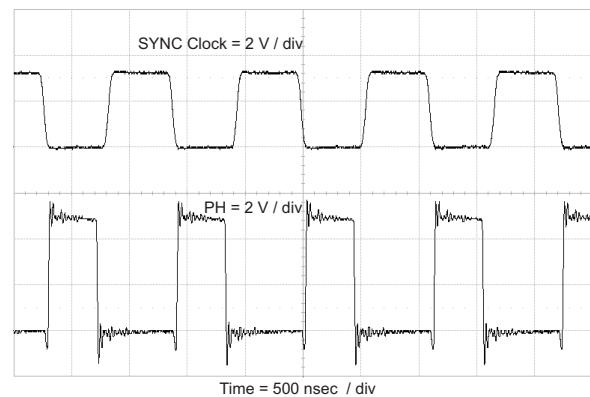

Figure 26. Plot of Synchronizing to System Clock

9.3.14 Power Good (PWRGD Pin)

The PWRGD pin output is an open-drain MOSFET. The output goes low when the VSENSE voltage enters the fault condition by falling below 91% or rising above 109% of the nominal internal reference voltage. There is a 2% hysteresis on the threshold voltage, so when the VSENSE voltage rises to the good condition above 93% or falls below 107% of the internal voltage reference, the PWRGD output MOSFET turns off. TI recommends to use a pullup resistor between 1 to 100 k Ω with a voltage source that is 6 V or less. PWRGD is in a valid state after the VIN input voltage is greater than 1.1 V.

9.3.15 Overvoltage Transient Protection (OVTP)

The TPS57114-EP incorporates an OVTP circuit to minimize voltage overshoot when recovering from output fault conditions or strong unload transients. The OVTP feature minimizes the output overshoot by implementing a circuit to compare the VSENSE pin voltage to the OVTP threshold, which is 109% of the internal voltage reference. The VSENSE pin voltage going greater than the OVTP threshold disables the high-side MOSFET, preventing current from flowing to the output and minimizing output overshoot. The VSENSE voltage dropping lower than the OVTP threshold allows the high-side MOSFET to turn on during the next clock cycle.

9.3.16 Thermal Shutdown

The device implements an internal thermal shutdown to protect itself if the junction temperature exceeds 168°C. The thermal shutdown forces the device to stop switching when the junction temperature exceeds the thermal trip threshold. When the die temperature decreases below 148°C, the device reinitiates the power-up sequence by discharging the SS pin to below 60 mV. The thermal shutdown hysteresis is 20°C.

Feature Description (continued)

9.3.17 Small-Signal Model for Loop Response

Figure 27 shows an equivalent model for the TPS57114-EP control loop which the user can model in a circuit-simulation program to check frequency response and dynamic load response. The error amplifier is a transconductance amplifier with a g_m of $245 \mu\text{S}$. The user can use an ideal voltage-controlled current source to model the error amplifier. Resistor R0 and capacitor C0 model the open-loop gain and frequency response of the amplifier. The 1-mV AC voltage source between nodes a and b effectively breaks the control loop for the frequency-response measurements. Plotting a or c versus frequency shows the small-signal response of the frequency compensation. Plotting a or b versus frequency shows the small-signal response of the overall loop. The user can check the dynamic loop response by replacing R_L with a current source having the appropriate load-step amplitude and step rate in a time domain analysis.

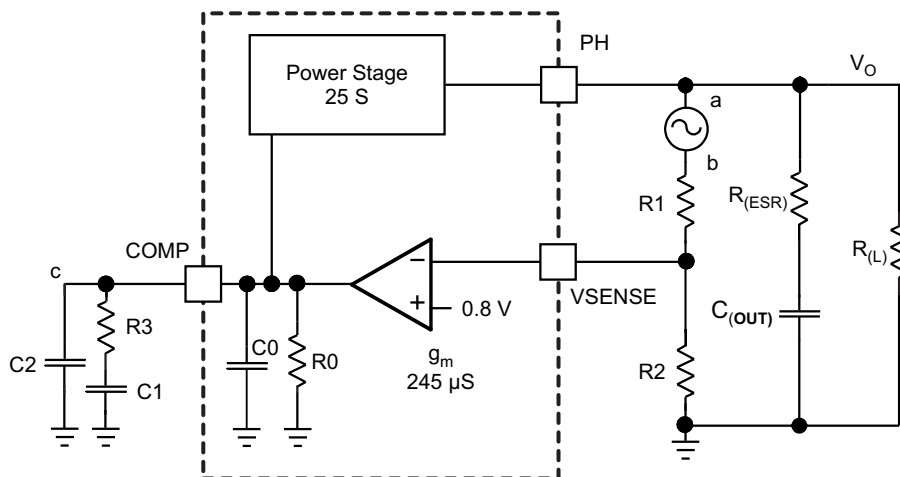
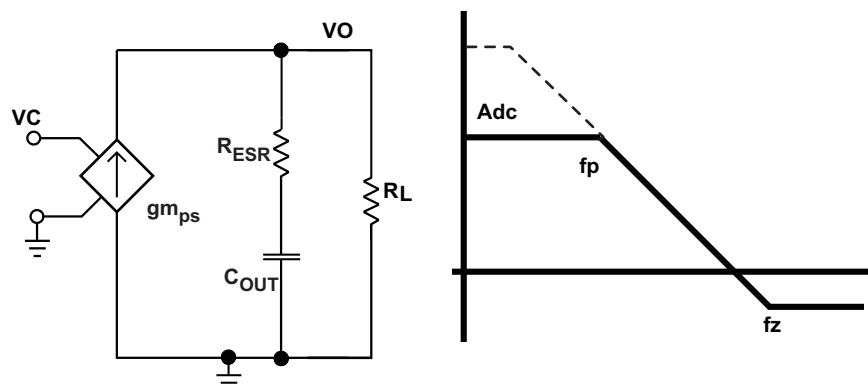

Figure 27. Small-Signal Model for Loop Response

9.3.18 Simple Small-Signal Model for Peak-Current Mode Control

Figure 27 is a simple small-signal model that the user can use to understand how to design the frequency compensation. An approximation of a voltage-controlled current source (duty-cycle modulator) supplying current to the output capacitor and load resistor can approximate the TPS57114-EP power stage. The control-to-output transfer function, shown in Equation 7, consists of a DC gain, one dominant pole, and one ESR zero. The quotient of the change in switch current divided by the change in COMP pin voltage (node c in Figure 27) is the power-stage transconductance. The g_m for the TPS57114-EP is 25 S. The low-frequency gain of the power-stage frequency response is the product of the transconductance and the load resistance, as shown in Equation 8. As the load current increases and decreases, the low-frequency gain decreases and increases, respectively. This variation with load may seem problematic at first glance, but the dominant pole moves with load current (see Equation 9). The dashed line in the right half of Figure 28 highlights the combined effect. As the load current decreases, the gain increases and the pole frequency lowers, keeping the 0-dB crossover frequency the same for the varying load conditions, which makes it easier to design the frequency compensation.

Feature Description (continued)

Figure 28. Simple Small-Signal Model and Frequency Response for Peak-Current Mode Control

$$\frac{v_o}{v_c} = A_{dc} \times \frac{\left(1 + \frac{s}{2\pi \times f_z}\right)}{\left(1 + \frac{s}{2\pi \times f_p}\right)} \quad (7)$$

$$A_{dc} = g_{m_{ps}} \times R_L \quad (8)$$

$$f_p = \frac{1}{C_{OUT} \times R_L \times 2\pi} \quad (9)$$

$$f_z = \frac{1}{C_{OUT} \times R_{ESR} \times 2\pi} \quad (10)$$

9.3.19 Small-Signal Model for Frequency Compensation

The TPS57114-EP uses a transconductance amplifier for the error amplifier and readily supports two of the commonly used frequency-compensation circuits. Figure 29 shows the compensation circuits. High-bandwidth power-supply designs most likely implement Type 2 circuits using low-ESR output capacitors. In Type 2A, inclusion of one additional high-frequency pole attenuates high-frequency noise.

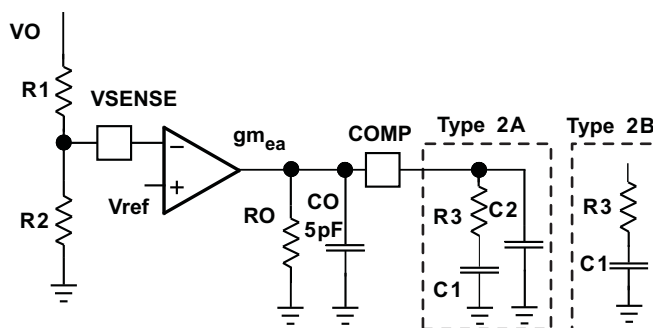
Figure 29. Types of Frequency Compensation

Feature Description (continued)

The design guidelines for TPS57114-EP loop compensation are as follows:

1. Calculate the modulator pole, $f_{p\text{mod}}$, and the ESR zero, f_{z1} , using [Equation 11](#) and [Equation 12](#). If the output voltage is a high percentage of the capacitor rating, it may be necessary to derate the output capacitor (C_{OUT}). Use the manufacturer information for the capacitor to derate the capacitor value. Use [Equation 13](#) and [Equation 14](#) to estimate a starting point for the crossover frequency, f_c . [Equation 13](#) is the geometric mean of the modulator pole and the ESR zero and [Equation 14](#) is the mean of the modulator pole and the switching frequency. Use the lower value of [Equation 13](#) or [Equation 14](#) as the maximum crossover frequency.

$$f_{p\text{ mod}} = \frac{I_{\text{out max}}}{2\pi \times V_{\text{out}} \times C_{\text{out}}} \quad (11)$$

$$f_{z\text{ mod}} = \frac{1}{2\pi \times R_{\text{esr}} \times C_{\text{out}}} \quad (12)$$

$$f_c = \sqrt{f_{p\text{ mod}} \times f_{z\text{ mod}}} \quad (13)$$

$$f_c = \sqrt{f_{p\text{ mod}} \times \frac{f_{\text{sw}}}{2}} \quad (14)$$

2. Determine R3 with:

$$R3 = \frac{2\pi \times f_c \times V_o \times C_{\text{OUT}}}{g_{m\text{ea}} \times V_{\text{ref}} \times g_{m\text{ps}}}$$

where

- $g_{m\text{ea}}$ is the amplifier gain (245 μS)
 - $g_{m\text{ps}}$ is the power stage gain (25 S)
- (15)

3. Place a compensation zero at the dominant pole $f_p = \frac{1}{C_{\text{OUT}} \times R_L \times 2\pi}$. Determine C1 with:

$$C1 = \frac{R_L \times C_{\text{OUT}}}{R3} \quad (16)$$

4. C2 is optional. Use it, if necessary, to cancel the 0 from the ESR of C_{OUT} .

$$C2 = \frac{R_{\text{esr}} \times C_{\text{OUT}}}{R3} \quad (17)$$

9.4 Device Functional Modes

9.4.1 RT (Resistor Timing) Mode

External resistor to ground can be connected to the RT/CLK pin, which enables the user to adjust the switching frequency. The device has an internal PLL on the RT/CLK pin that synchronizes the power-switch turn on to the falling edge of an external system clock. The frequency is adjustable from 200 to 2000 kHz by using external resistor maximum of 700 k Ω or minimum of 85 k Ω (see [Constant Switching Frequency and Timing Resistor \(RT/CLK Pin\)](#)).

Device Functional Modes (continued)

9.4.2 CLK (External Clock) Mode

The RT/CLK pin synchronizes the converter to an external system clock. To implement the synchronization feature in a system, connect a square wave to the RT/CLK pin with an on-time of at least 75 ns. If the pin goes above the PLL upper threshold, a mode change occurs, and the pin becomes a synchronization input. The device disables the internal amplifier and the terminal is a high-impedance clock input to the internal PLL. If clocking edges stop, the device re-enables the internal amplifier and the mode returns to the frequency set by the resistor. The square-wave amplitude at this pin must transition lower than 0.6 V and higher than 1.6 V, typically. The synchronization frequency range is 300 to 2000 kHz. The rising edge of PH synchronizes to the falling edge of the RT/CLK pin.

10 Application and Implementation

10.1 Application Information

10.1.1 Sequencing

The user can implement many of the common power-supply sequencing methods using the SS/TR, EN, and PWRGD pins. Implement the sequential method by using an open-drain or collector output of the power-on-reset pin of another device. Figure 30 shows the sequential method. Coupling power-good to the EN pin on the TPS57114-EP enables the second power supply after the primary supply reaches regulation.

The user can accomplish ratiometric start-up by connecting the SS/TR pins together. The regulator outputs ramp up and reach regulation at the same time. When calculating the slow-start time, double the pullup current source in Equation 4. Figure 32 shows the ratiometric method.

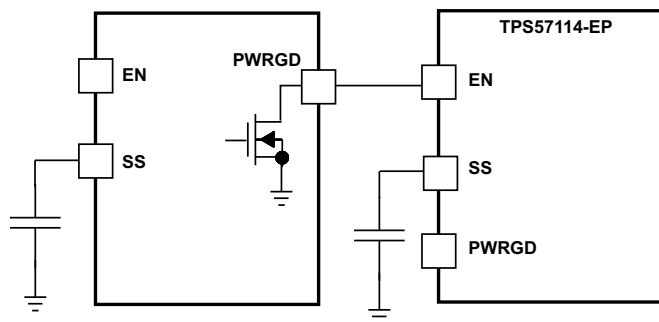

Figure 30. Sequential Start-Up Sequence

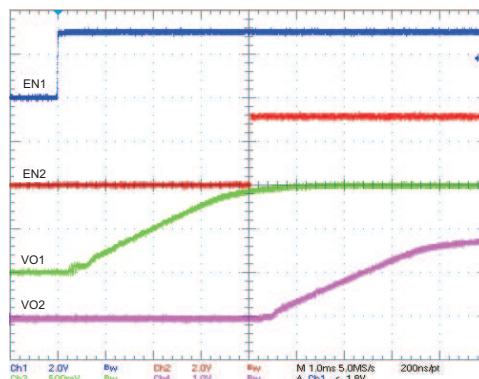

Figure 31. Sequential Start-Up Using EN and PWRGD

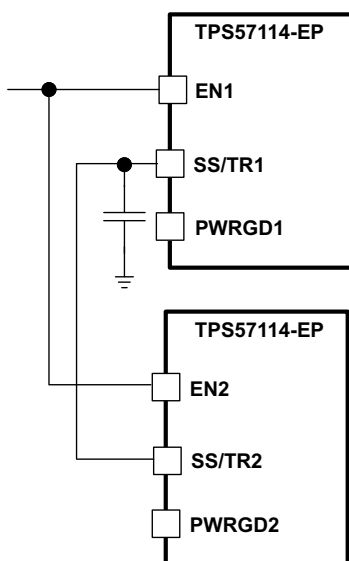

Figure 32. Schematic for Ratiometric Start-Up Sequence

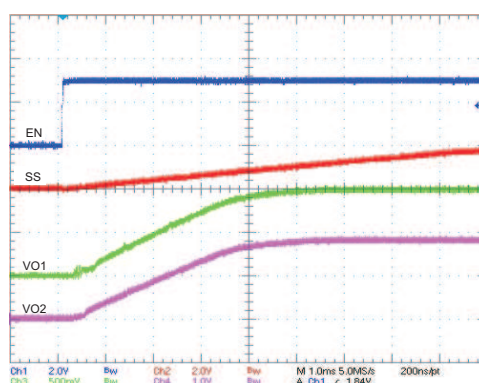

Figure 33. Ratiometric Start-Up With Vout1 Leading Vout2

Application Information (continued)

The user can implement ratiometric and simultaneous power-supply sequencing by connecting the resistor network of R1 and R2 shown in Figure 34 to the output of the power supply that requires tracking, or to another voltage reference source. Using Equation 18 and Equation 19 allows calculation of the tracking resistors to initiate the Vout2 slightly before, after, or at the same time as Vout1. Equation 20 is the voltage difference between Vout1 and Vout2. The ΔV variable is 0 V for simultaneous sequencing. To minimize the effect of the inherent SS/TR-to-VSENSE offset ($V_{ssoffset}$) in the slow-start circuit and the offset created by the pullup current source (I_{ss}) and tracking resistors, the equations include $V_{ssoffset}$ and I_{ss} as variables. To design a ratiometric start-up in which the Vout2 voltage is slightly greater than the Vout1 voltage when Vout2 reaches regulation, use a negative number in Equation 18 through Equation 20 for ΔV . Equation 20 results in a positive number for applications in which Vout2 is slightly lower than Vout1 when achieving Vout2 regulation. The requirement to pull the SS/TR pin below 60 mV before starting after an EN, UVLO, or thermal shutdown fault necessitates careful selection of the tracking resistors to ensure the device can restart after a fault. Make sure the calculated R1 value from Equation 18 is greater than the value calculated in Equation 21 to ensure the device can recover from a fault. As the SS/TR voltage becomes more than 85% of the nominal reference voltage, $V_{ssoffset}$ becomes larger as the slow-start circuits gradually hand off the regulation reference to the internal voltage reference. The SS/TR pin voltage must be greater than 1.1 V for a complete handoff to the internal voltage reference, as shown in Figure 33.

$$R1 = \frac{V_{out2} + \Delta V}{V_{ref}} \times \frac{V_{ssoffset}}{I_{ss}} \quad (18)$$

$$R2 = \frac{V_{ref} \times R1}{V_{out2} + \Delta V - V_{ref}} \quad (19)$$

$$\Delta V = V_{out1} - V_{out2} \quad (20)$$

$$R1 > 2930 \times V_{out1} - 145 \times \Delta V \quad (21)$$

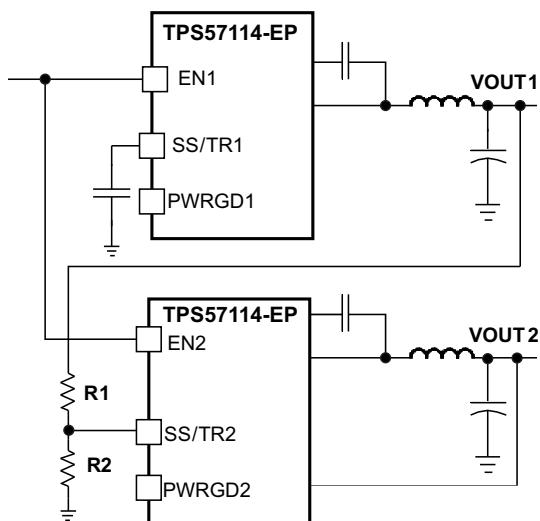

Figure 34. Ratiometric and Simultaneous Start-Up Sequence

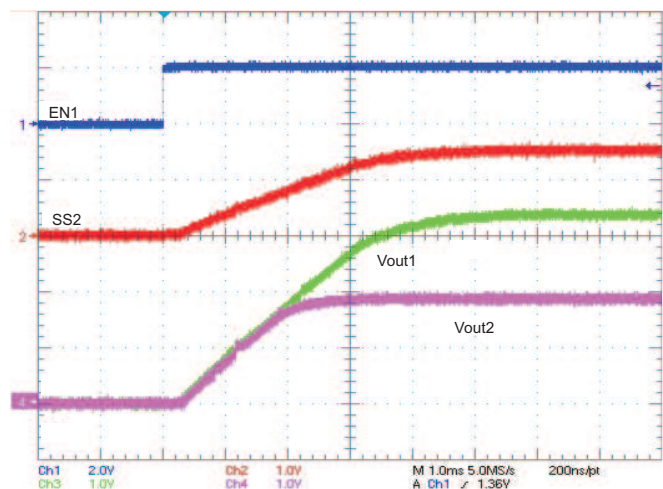

Figure 35. Ratiometric Start-Up Using Coupled SS/TR Pins

10.2 Typical Application

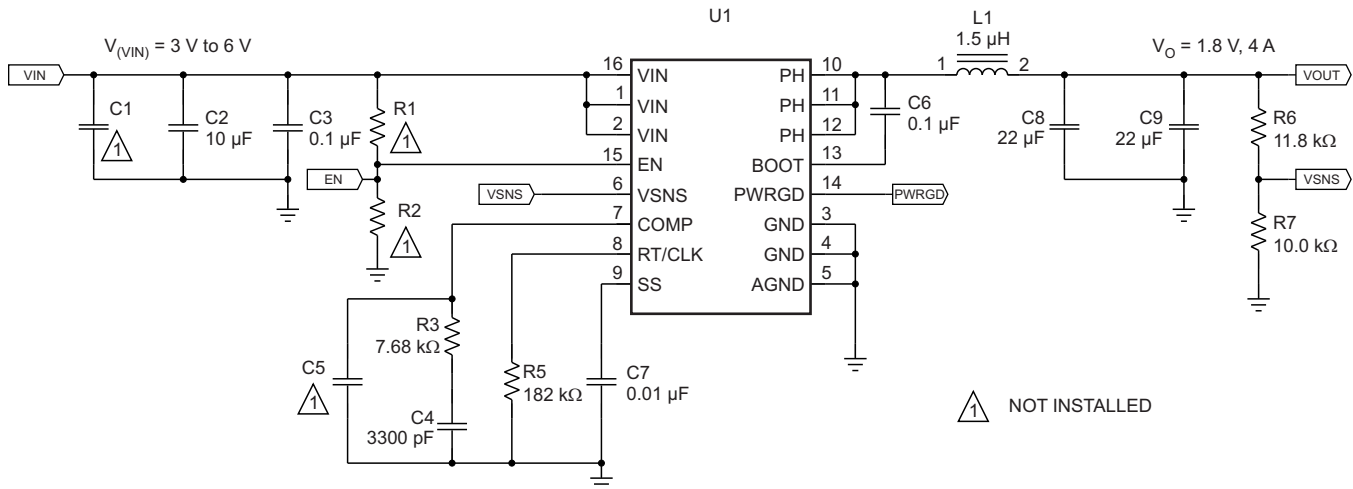

Figure 36. High-Frequency, 1.8-V Output Power-Supply Design With Adjusted UVLO

10.2.1 Design Requirements

This example details the design of a high-frequency switching regulator using ceramic output capacitors. This design is available as the HPA375 evaluation module (EVM). To start the design process, it is necessary to know a few parameters. Determination of these parameters typically occurs at the system level. For this example, start with the following known parameters:

Table 1. Design Parameters

DESIGN PARAMETER	EXAMPLE VALUE
Output voltage	1.8 V
Transient response, 1- to 2-A load step	$\Delta V_{out} = 5\%$
Maximum output current	3.5 A
Input voltage	5 V nominal, 3 to 5 V
Output-voltage ripple	<30 mVp-p
Switching frequency (f_{SW})	1000 kHz

10.2.2 Detailed Design Procedure

10.2.2.1 Selecting the Switching Frequency

The first step is to decide on a switching frequency for the regulator. Typically, the user wants to choose the highest switching frequency possible, because this produces the smallest solution size. The high switching frequency allows for lower-valued inductors and smaller output capacitors compared to a power supply that switches at a lower frequency. However, the highest switching frequency causes extra switching losses, which hurt the performance of the converter. The converter is capable of running from 300 kHz to 2 MHz. Unless a small solution size is the ultimate goal, select a moderate switching frequency of 1 MHz to achieve both a small solution size and high-efficiency operation. Using Equation 5, calculate R5 to be 180 kΩ. Choose a standard 1% 182-kΩ value for the design.

10.2.2.2 Output Inductor Selection

The inductor selected works for the entire TPS57114-EP input-voltage range. To calculate the value of the output inductor, use Equation 22. K_{IND} is a coefficient that represents the amount of inductor ripple current relative to the maximum output current. The output capacitor filters the inductor ripple current. Therefore, choosing high inductor ripple currents impacts the selection of the output capacitor, because the output capacitor must have a ripple-current rating equal to or greater than the inductor ripple current. In general, the inductor ripple value is at the discretion of the designer; however, K_{IND} is normally from 0.1 to 0.3 for the majority of applications.

For this design example, use $K_{IND} = 0.3$, which results in a calculated inductor value of $1.36 \mu\text{H}$. For this design, choose the nearest standard value: $1.5 \mu\text{H}$. For the output-filter inductor, it is important not to exceed the rms-current and saturation-current ratings. Find the rms and peak inductor current using [Equation 24](#) and [Equation 25](#).

For this design, the rms inductor current is 4 A and the peak inductor current is 4.6 A. The chosen inductor is a Coilcraft XLA4020-152ME_ or equivalent. It has a saturation current rating of 9.6 A and an rms current rating of 7.5 A.

The current flowing through the inductor is the inductor ripple current plus the output current. During power-up, faults, or transient load conditions, the inductor current can increase above the calculated peak inductor-current level calculated previously. In transient conditions, the inductor current can increase up to the switch-current limit of the device. For this reason, the most conservative approach is to specify an inductor with a saturation current rating equal to or greater than the switch-current limit rather than the peak inductor current.

$$L1 = \frac{V_{inmax} - V_{out}}{I_o \times K_{IND}} \times \frac{V_{out}}{V_{inmax} \times f_{sw}} \quad (22)$$

$$I_{ripple} = \frac{V_{inmax} - V_{out}}{L1} \times \frac{V_{out}}{V_{inmax} \times f_{sw}} \quad (23)$$

$$I_{Lrms} = \sqrt{I_o^2 + \frac{1}{12} \times \left(\frac{V_o \times (V_{inmax} - V_o)}{V_{inmax} \times L1 \times f_{sw}} \right)^2} \quad (24)$$

$$I_{Lpeak} = I_{out} + \frac{I_{ripple}}{2} \quad (25)$$

10.2.2.3 Output Capacitor

To select the value of the output capacitor, use three primary considerations. The output capacitor determines the modulator pole, the output-voltage ripple, and how the regulator responds to a large change in load current. Base the output-capacitance selection on the most stringent of these three criteria.

The desired response to a large change in the load current is the first criterion. The output capacitor must supply the load with current when the regulator cannot. This situation would occur if there are desired hold-up times for the regulator where the output capacitor must hold the output voltage above a certain level for a specified amount of time after removal of the input power. The regulator is temporarily not able to supply sufficient output current if there is a large, fast increase in the current needs of the load, such as transitioning from no load to a full load. The regulator usually requires two or more clock cycles for the control loop to detect the change in load current and output voltage and adjust the duty cycle to react to the change. The output capacitor size must be capable of supplying the extra current to the load until the control loop responds to the load change. The output capacitance must be large enough to supply the difference in current for two clock cycles while only allowing a tolerable amount of droop in the output voltage. [Equation 26](#) shows the minimum output capacitance necessary to accomplish this.

For this example, the transient load response is specified as a 5% change in V_{out} for a load step from 0 A (no load) to 1.5 A (50% load). For this example, $\Delta I_{out} = 1.5 - 0 = 1.5 \text{ A}$ and $\Delta V_{out} = 0.05 \times 1.8 = 0.09 \text{ V}$. Using these numbers gives a minimum capacitance of $33 \mu\text{F}$. This value does not take the ESR of the output capacitor into account in the output voltage change. For ceramic capacitors, the ESR is usually small enough to ignore in this calculation.

[Equation 27](#) calculates the minimum output capacitance needed to meet the output-voltage ripple specification. In this case, the maximum output voltage ripple is 30 mV. Under this requirement, [Equation 27](#) yields $2.3 \mu\text{F}$.

$$C_o > \frac{2 \times \Delta I_{out}}{f_{sw} \times \Delta V_{out}}$$

where

- ΔI_{out} is the change in output current
 - f_{sw} is the regulator switching frequency
 - ΔV_{out} is the allowable change in the output voltage
- (26)

$$C_o > \frac{1}{8 \times f_{sw}} \times \frac{1}{\frac{V_{oripple}}{I_{ripple}}}$$

where

- f_{sw} is the switching frequency
 - $V_{oripple}$ is the maximum allowable output-voltage ripple
 - I_{ripple} is the inductor ripple current
- (27)

Equation 28 calculates the maximum ESR an output capacitor can have to meet the output-voltage ripple specification. **Equation 28** indicates the ESR should be less than 55 mΩ. In this case, the ESR of the ceramic capacitor is much less than 55 mΩ.

Factoring in additional capacitance deratings for aging, temperature, and DC bias increases this minimum value. This example uses two 22-μF, 10-V X5R ceramic capacitors with 3 mΩ of ESR.

Capacitors generally have limits to the amount of ripple current they can handle without failing or producing excess heat. Specify an output capacitor that can support the inductor ripple current. Some capacitor data sheets specify the root-mean-square (rms) value of the maximum ripple current. Use **Equation 29** to calculate the rms ripple current that the output capacitor must support. For this application, **Equation 29** yields 333 mA.

$$Resr < \frac{V_{oripple}}{I_{ripple}}$$
(28)

$$I_{corms} = \frac{V_{out} \times (V_{inmax} - V_{out})}{\sqrt{12} \times V_{inmax} \times L1 \times f_{sw}}$$
(29)

10.2.2.4 Input Capacitor

The TPS57114-EP requires a high-quality ceramic, type X5R or X7R, input decoupling capacitor with at least 4.7 μF of effective capacitance, and in some applications a bulk capacitance. The effective capacitance includes any DC-bias effects. The voltage rating of the input capacitor must be greater than the maximum input voltage. The capacitor must also have a ripple-current rating greater than the maximum input-current ripple of the TPS57114-EP. Calculate the input ripple current using **Equation 30**.

The value of a ceramic capacitor varies significantly over temperature and the amount of DC bias applied to the capacitor. The capacitance variations due to temperature can be minimized by selecting a dielectric material that is stable over temperature. The dielectrics are usually selected for power regulator capacitors are X5R and X7R ceramic because they have a high capacitance-to-volume ratio and are fairly stable over temperature. Also select the output capacitor with the DC bias taken into account. The capacitance value of a capacitor decreases as the DC bias across a capacitor increases.

This design example requires a ceramic capacitor with at least a 10-V voltage rating to support the maximum input voltage. The selections for this example are one 10-μF and one 0.1-μF 10-V capacitor in parallel. The input capacitance value determines the input ripple voltage of the regulator. Calculate the input voltage ripple using **Equation 31**. Using the design example values, $I_{outmax} = 4$ A, $C_{in} = 10$ μF, and $f_{sw} = 1$ MHz, yields an input-voltage ripple of 100 mV and an rms input-ripple current of 1.96 A.

$$I_{cirms} = I_{out} \times \sqrt{\frac{V_{out}}{V_{inmin}} \times \frac{(V_{inmin} - V_{out})}{V_{inmin}}}$$
(30)

$$\Delta V_{in} = \frac{I_{outmax} \times 0.25}{C_{in} \times f_{sw}}$$
(31)

10.2.2.5 Slow-Start Capacitor

The slow-start capacitor determines the minimum amount of time it takes for the output voltage to reach its nominal programmed value during power up. Slow start is useful if a load requires a controlled rate of voltage slew. Slow start is also used if the output capacitance is large and would require large amounts of current to charge the capacitor quickly to the output-voltage level. The large currents necessary to charge the capacitor may make the TPS57114-EP reach the current limit, or excessive current draw from the input power supply may cause the input voltage rail to sag. Limiting the output-voltage slew rate solves both of these problems.

Calculate the slow-start capacitor value using [Equation 32](#). For the example circuit, the slow-start time is not too critical because the output capacitor value is 44 μF , which does not require much current to charge to 1.8 V. The example circuit has the slow-start time set to an arbitrary value of 4 ms, which requires a 10-nF capacitor. In TPS57114-EP, I_{ss} is 2.2 μA and V_{ref} is 0.8 V.

$$C_{ss}(\text{nF}) = \frac{T_{ss}(\text{ms}) \times I_{ss}(\mu\text{A})}{V_{ref}(\text{V})} \quad (32)$$

10.2.2.6 Bootstrap Capacitor Selection

Connect a 0.1- μF ceramic capacitor between the BOOT and PH pins for proper operation. TI recommends using a ceramic capacitor with X5R or better-grade dielectric. The capacitor should have a 10-V, or higher, voltage rating.

10.2.2.7 Output-Voltage and Feedback-Resistor Selection

For the design example, the selection for R_6 is 100 k Ω . Using [Equation 33](#), calculate R_7 as 80 k Ω . The nearest standard 1% resistor is 80.5 k Ω .

$$R_7 = \frac{V_{ref}}{V_o - V_{ref}} R_6 \quad (33)$$

Due to the internal design of the TPS57114-EP, a minimum output voltage limit exists for any given input voltage. The output voltage can never be lower than the internal voltage reference of 0.8 V. Above 0.8 V, an output voltage limit may exist due to the minimum controllable on-time. In this case, [Equation 34](#) gives the minimum output voltage.

$$V_{outmin} = \text{Ontimemin} \times F_{smax} \times (V_{inmax} - I_{outmin} \times 2 \times R_{DS}) - I_{outmin} \times (R_L + R_{DS})$$

where

- V_{outmin} = Minimum achievable output voltage
- Ontimemin = Minimum controllable on-time (65 ns, typical; 120 ns, no load)
- F_{smax} = Maximum switching frequency, including tolerance
- V_{inmax} = Maximum input voltage
- I_{outmin} = Minimum load current
- R_{DS} = Minimum high-side MOSFET on-resistance (15 to 19 m Ω)
- R_L = Series resistance of output inductor

(34)

There is also a maximum achievable output voltage, which is limited by the minimum off-time. [Equation 35](#) gives the maximum output voltage

$$V_{outmax} = (1 - \text{Offtimemax} \times F_{smax}) \times (V_{inmin} - I_{outmax} \times 2 \times R_{DS}) - I_{outmax} \times (R_L + R_{DS})$$

where

- V_{outmax} = Maximum achievable output voltage
- Offtimemax = Maximum off-time (60 ns, typical)
- F_{smax} = Maximum switching frequency, including tolerance
- V_{inmin} = Minimum input voltage
- I_{outmax} = Maximum load current
- R_{DS} = Maximum high-side MOSFET on-resistance (19 to 30 m Ω)
- R_L = Series resistance of output inductor

(35)

10.2.2.8 Compensation

Several industry techniques are used to compensate DC-DC regulators. The method presented here is easy to calculate and yields high phase margins. For most conditions, the regulator has a phase margin between 60° and 90°. The method presented here ignores the effects of the slope compensation that is internal to the TPS57114-EP. Because of ignoring the slope compensation, the actual crossover frequency is usually lower than the crossover frequency used in the calculations. Use [SwitcherPro](#) software for a more-accurate design.

To get started, calculate the modulator pole, $f_{p\text{mod}}$, and the ESR zero, f_{z1} , using [Equation 36](#) and [Equation 37](#). For C_{out} , derating the capacitor is not necessary, as the 1.8-V output is a small percentage of the 10-V capacitor rating. If the output is a high percentage of the capacitor rating, use the manufacturer information for the capacitor to derate the capacitor value. Use [Equation 38](#) and [Equation 39](#) to estimate a starting point for the crossover frequency, f_c . For the example design, $f_{p\text{mod}}$ is 6.03 kHz and $f_{z\text{mod}}$ is 1210 kHz. [Equation 38](#) is the geometric mean of the modulator pole and the ESR zero, and [Equation 39](#) is the mean of the modulator pole and the switching frequency. [Equation 38](#) yields 85.3 kHz and [Equation 39](#) gives 54.9 kHz. Use the lower value of [Equation 38](#) or [Equation 39](#) as the approximate crossover frequency. For this example, f_c is 56 kHz. Next, calculate the compensation components. Use a resistor in series with a capacitor to create a compensating zero. A capacitor in parallel with these two components forms the compensating pole (if needed).

$$f_{p\text{mod}} = \frac{I_{out\text{max}}}{2\pi \times V_{out} \times C_{out}} \quad (36)$$

$$f_{z\text{mod}} = \frac{1}{2\pi \times R_{esr} \times C_{out}} \quad (37)$$

$$f_c = \sqrt{f_{p\text{mod}} \times f_{z\text{mod}}} \quad (38)$$

$$f_c = \sqrt{f_{p\text{mod}} \times \frac{f_{sw}}{2}} \quad (39)$$

The compensation design takes the following steps:

1. Set up the anticipated crossover frequency. Use [Equation 40](#) to calculate the resistor value for the compensation network. In this example, the anticipated crossover frequency (f_c) is 56 kHz. The power-stage gain ($g_{m_{ps}}$) is 25 S, and the error-amplifier gain ($g_{m_{ea}}$) is 245 μ S.

$$R3 = \frac{2\pi \times f_c \times V_o \times C_o}{G_m \times V_{ref} \times V_{I_{gm}}} \quad (40)$$

2. Place compensation zero at the pole formed by the load resistor and the output capacitor. Calculate the capacitor for the compensation network using [Equation 41](#).

$$C3 = \frac{R_o \times C_o}{R3} \quad (41)$$

3. The user can add an additional pole to attenuate high-frequency noise. In this application, it is not necessary to add it.

From the preceding procedure, the compensation network includes a 7.68-k Ω resistor and a 3300-pF capacitor.

10.2.2.9 Power-Dissipation Estimate

The following formulas show how to estimate the IC power dissipation under continuous-conduction mode (CCM) operation. The power dissipation of the IC (P_{tot}) includes conduction loss (P_{con}), dead-time loss (P_d), switching loss (P_{sw}), gate-drive loss (P_{gd}), and supply-current loss (P_q).

$$P_{con} = I_o^2 \times r_{DS(on)_Temp} \quad (42)$$

$$P_d = f_{sw} \times I_o \times 0.7 \times 60 \times 10^{-9} \quad (43)$$

$$P_{sw} = 1 / 2 \times V_{in} \times I_o \times f_{sw} \times 8 \times 10^{-9} \quad (44)$$

$$P_{gd} = 2 \times V_{in} \times f_{sw} \times 2 \times 10^{-9} \quad (45)$$

$$P_q = V_{in} \times 515 \times 10^{-6} \quad (46)$$

where:

- I_O is the output current (A)
- $r_{DS(on)_Temp}$ is the on-resistance of the high-side MOSFET at a given temperature (Ω)
- V_{in} is the input voltage (V)
- f_{sw} is the switching frequency (Hz)

So

$$P_{tot} = P_{con} + P_d + P_{sw} + P_{gd} + P_q \quad (47)$$

For a given T_A ,

$$T_J = T_A + R_{th} \times P_{tot} \quad (48)$$

For a given $T_{JMAX} = 150^\circ\text{C}$,

$$T_{AMAX} = T_{JMAX} - R_{th} \times P_{tot} \quad (49)$$

where:

- P_{tot} is the total device power dissipation (W)
- T_A is the ambient temperature ($^\circ\text{C}$)
- T_J is the junction temperature ($^\circ\text{C}$)
- R_{th} is the thermal resistance of the package ($^\circ\text{C}/\text{W}$)
- T_{JMAX} is maximum junction temperature ($^\circ\text{C}$)
- T_{AMAX} is maximum ambient temperature ($^\circ\text{C}$)

Additional power losses in the regulator circuit occur due to the inductor ac and dc losses and trace resistance that impact the overall efficiency of the regulator.

10.2.3 Application Curves

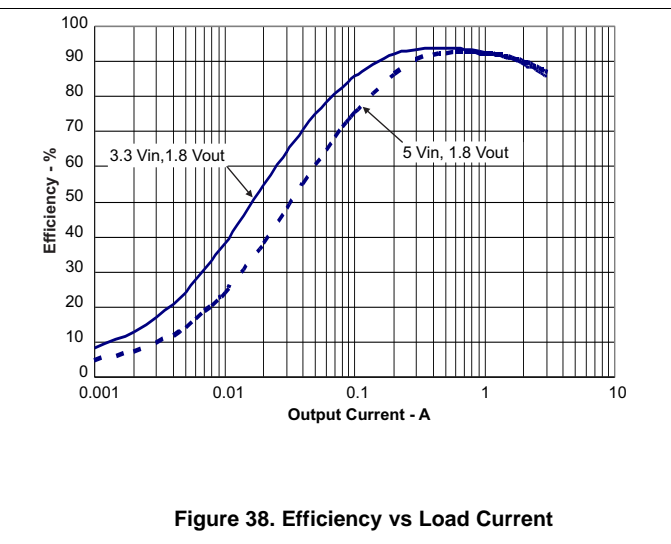
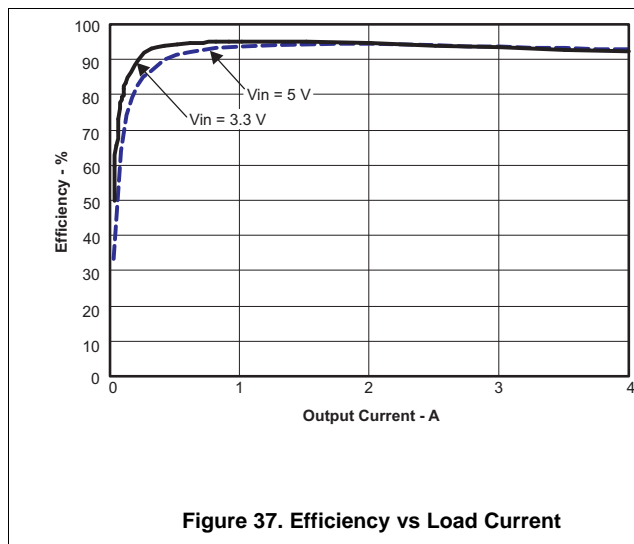

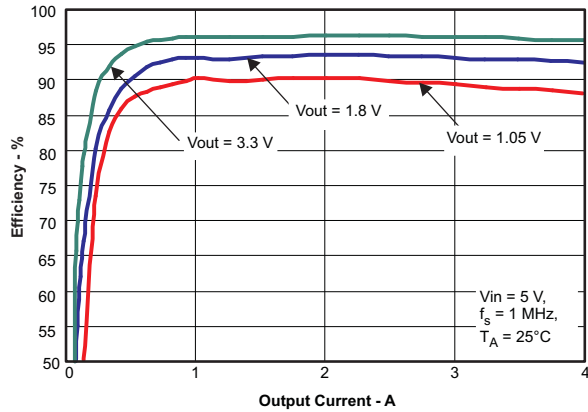

Figure 39. Efficiency vs Load Current

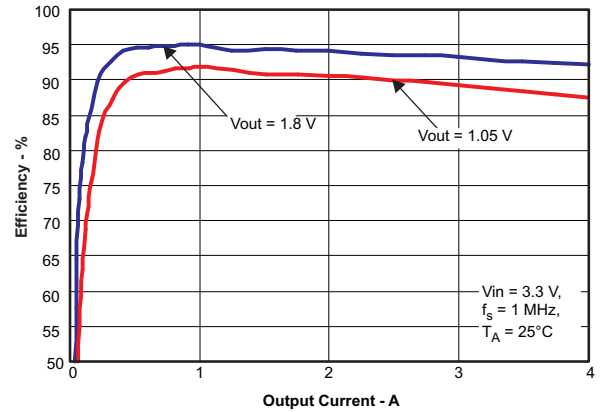

Figure 40. Efficiency vs Load Current

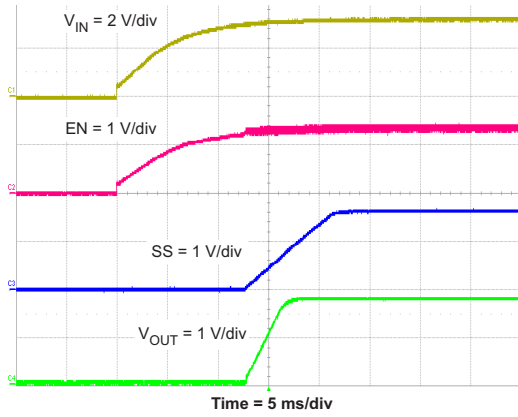

Figure 41. Power-Up VOUT, VIN

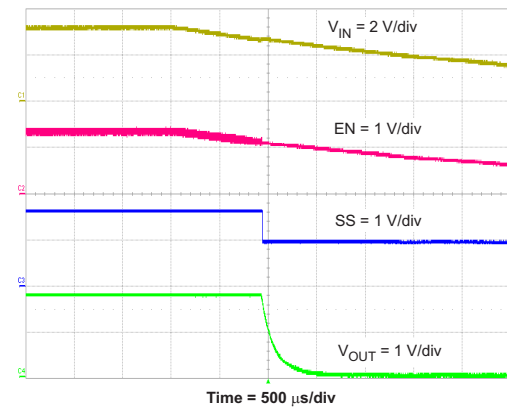

Figure 42. Power-Down VOUT, VIN

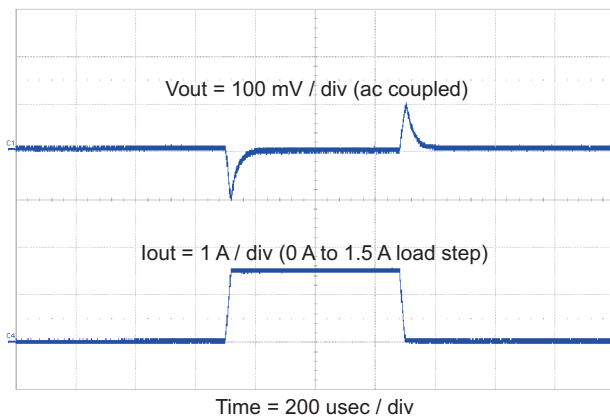

Figure 43. Transient Response, 1.5-A Step

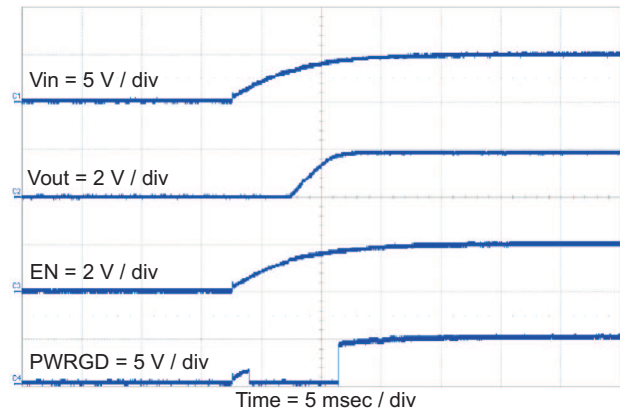

Figure 44. Power-Up VOUT, VIN

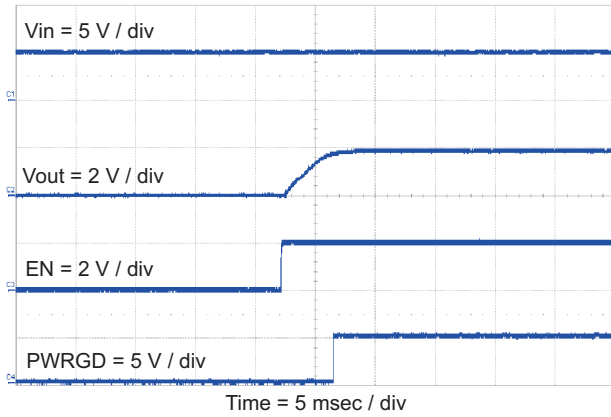

Figure 45. Power-Up VOUT, EN

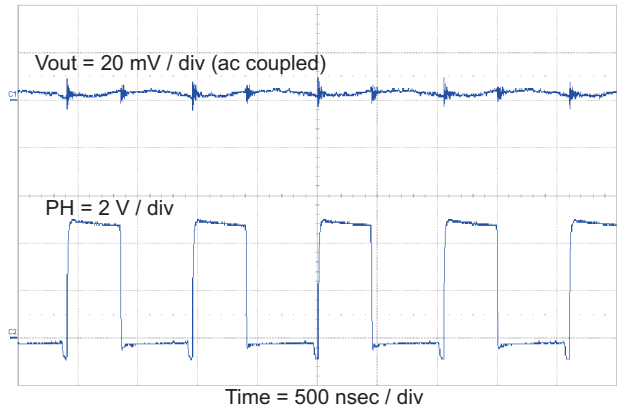

Figure 46. Output Ripple, 3.5 A

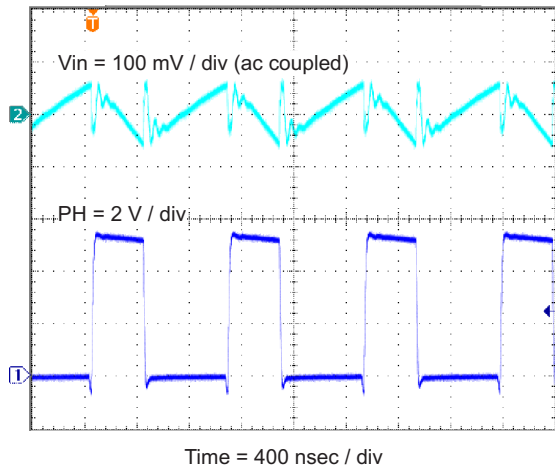

Figure 47. Input Ripple, 3.5 A

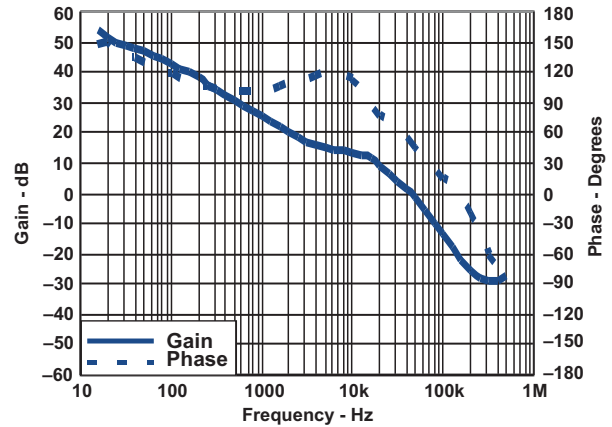

Figure 48. Closed-Loop Response, VIN (5 V), 3.5 A

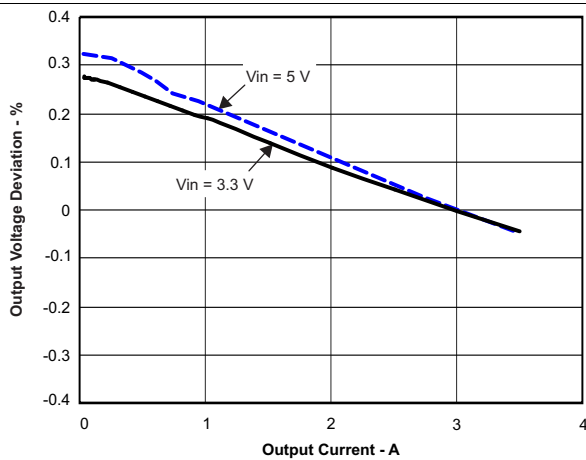

Figure 49. Load Regulation vs Load Current

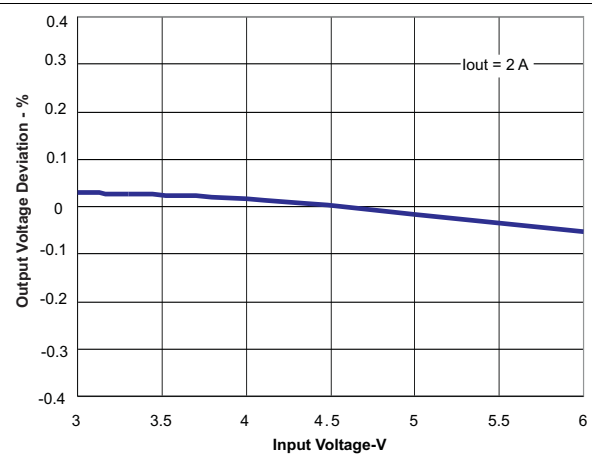

Figure 50. Regulation vs Input Voltage

11 Power Supply Recommendations

This device is designed to operate from an input voltage supply range between 2.95 and 6 V. This input supply should be well regulated. If the input supply is located more than a few inches from the TPS57114-EP converter, additional bulk capacitance may be required in addition to the ceramic bypass capacitors. A tantalum capacitor with a value of 47 μF is a typical choice; however, this may vary depending upon the output power being delivered.

12 Layout

12.1 Layout Guidelines

Layout is a critical portion of good power-supply design. There are several signal paths that conduct fast-changing currents or voltages that can interact with stray inductance or parasitic capacitance to generate noise or degrade the power-supply performance. Take care to minimize the loop area formed by the bypass capacitor connections and the VIN pins. See [Layout Example](#) for a PCB layout example. Tie the GND pins and AGND pin directly to the thermal pad under the IC. Connect the thermal pad to any internal PCB ground planes using multiple vias directly under the IC. Use additional vias to connect the top-side ground area to the internal planes near the input and output capacitors. For operation at full-rated load, the top-side ground area along with any additional internal ground planes must provide adequate heat dissipating area.

Locate the input bypass capacitor as close to the IC as possible. Route the PH pin to the output inductor. Because the PH connection is the switching node, locate the output inductor close to the PH pins and minimize the area of the PCB conductor to prevent excessive capacitive coupling. Also, locate the boot capacitor close to the device. Connect the sensitive analog ground connections for the feedback voltage divider, compensation components, slow-start capacitor, and frequency-set resistor to a separate analog ground trace as shown. The RT/CLK pin is particularly sensitive to noise, so locate the RT resistor as close as possible to the IC and connect it with minimal lengths of trace. Place the additional external components approximately as shown. It may be possible to obtain acceptable performance with alternative PCB layout. However, this layout, meant as a guideline, produces good results.

12.2 Layout Example

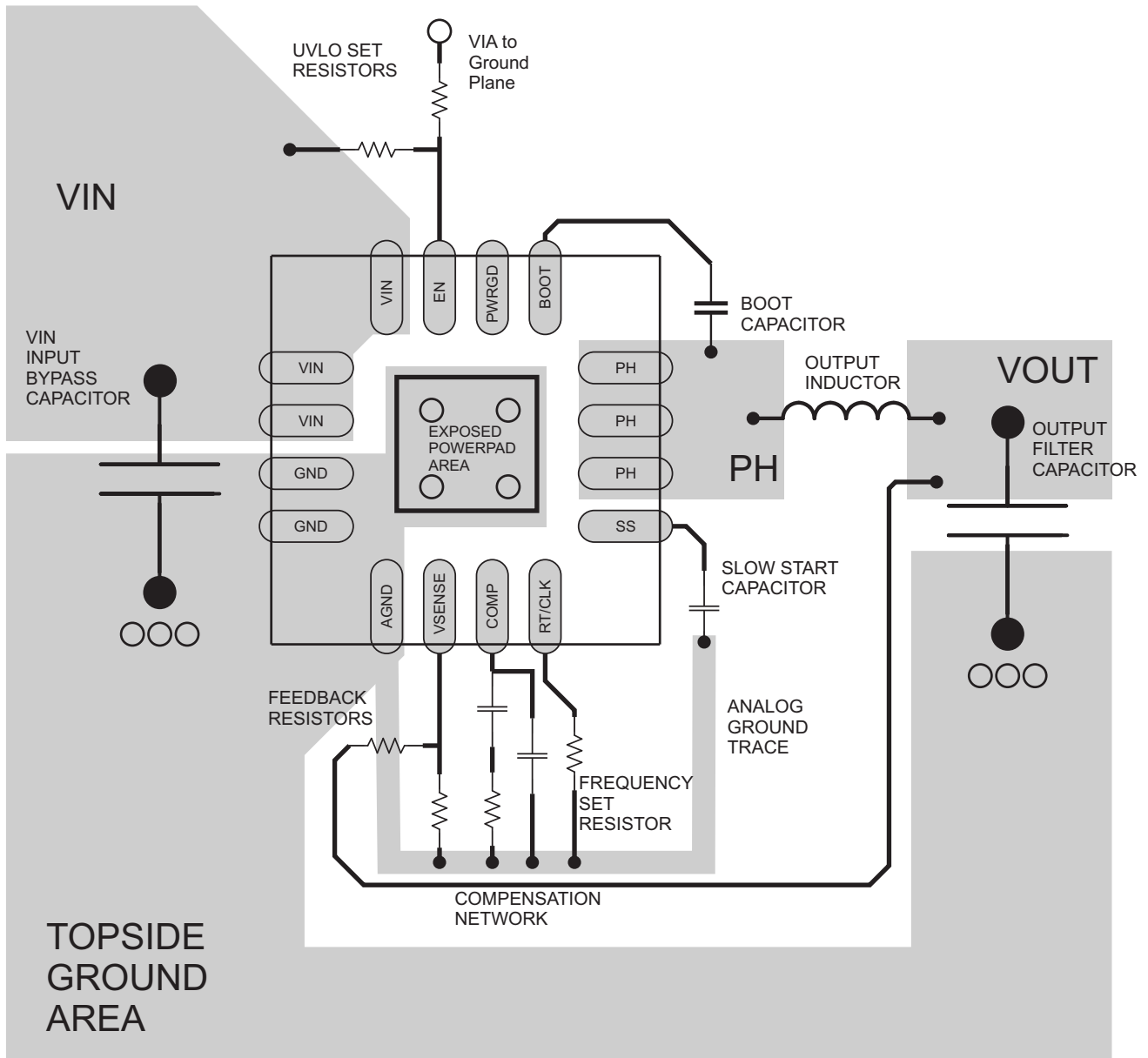

○ VIA to Ground Plane

13 Device and Documentation Support

13.1 Trademarks

SWIFT, SwitcherPro are trademarks of Texas Instruments.

13.2 Electrostatic Discharge Caution



These devices have limited built-in ESD protection. The leads should be shorted together or the device placed in conductive foam during storage or handling to prevent electrostatic damage to the MOS gates.

13.3 Glossary

[SLYZ022](#) — *TI Glossary*.

This glossary lists and explains terms, acronyms, and definitions.

14 Mechanical, Packaging, and Orderable Information

The following pages include mechanical, packaging, and orderable information. This information is the most current data available for the designated devices. This data is subject to change without notice and revision of this document. For browser-based versions of this data sheet, refer to the left-hand navigation.

PACKAGING INFORMATION

Orderable Device	Status (1)	Package Type	Package Drawing	Pins	Package Qty	Eco Plan (2)	Lead/Ball Finish (6)	MSL Peak Temp (3)	Op Temp (°C)	Device Marking (4/5)	Samples
TPS57114MRTETEP	ACTIVE	WQFN	RTE	16	250	Green (RoHS & no Sb/Br)	NIPDAU	Level-3-260C-168 HR	-55 to 125	7114M	Samples
V62/14612-01XE	ACTIVE	WQFN	RTE	16	250	Green (RoHS & no Sb/Br)	NIPDAU	Level-3-260C-168 HR	-55 to 125	7114M	Samples

(1) The marketing status values are defined as follows:

ACTIVE: Product device recommended for new designs.

LIFEBUY: TI has announced that the device will be discontinued, and a lifetime-buy period is in effect.

NRND: Not recommended for new designs. Device is in production to support existing customers, but TI does not recommend using this part in a new design.

PREVIEW: Device has been announced but is not in production. Samples may or may not be available.

OBsolete: TI has discontinued the production of the device.

(2) **RoHS:** TI defines "RoHS" to mean semiconductor products that are compliant with the current EU RoHS requirements for all 10 RoHS substances, including the requirement that RoHS substance do not exceed 0.1% by weight in homogeneous materials. Where designed to be soldered at high temperatures, "RoHS" products are suitable for use in specified lead-free processes. TI may reference these types of products as "Pb-Free".

RoHS Exempt: TI defines "RoHS Exempt" to mean products that contain lead but are compliant with EU RoHS pursuant to a specific EU RoHS exemption.

Green: TI defines "Green" to mean the content of Chlorine (Cl) and Bromine (Br) based flame retardants meet JS709B low halogen requirements of <=1000ppm threshold. Antimony trioxide based flame retardants must also meet the <=1000ppm threshold requirement.

(3) MSL, Peak Temp. - The Moisture Sensitivity Level rating according to the JEDEC industry standard classifications, and peak solder temperature.

(4) There may be additional marking, which relates to the logo, the lot trace code information, or the environmental category on the device.

(5) Multiple Device Markings will be inside parentheses. Only one Device Marking contained in parentheses and separated by a "~" will appear on a device. If a line is indented then it is a continuation of the previous line and the two combined represent the entire Device Marking for that device.

(6) Lead/Ball Finish - Orderable Devices may have multiple material finish options. Finish options are separated by a vertical ruled line. Lead/Ball Finish values may wrap to two lines if the finish value exceeds the maximum column width.

Important Information and Disclaimer:The information provided on this page represents TI's knowledge and belief as of the date that it is provided. TI bases its knowledge and belief on information provided by third parties, and makes no representation or warranty as to the accuracy of such information. Efforts are underway to better integrate information from third parties. TI has taken and continues to take reasonable steps to provide representative and accurate information but may not have conducted destructive testing or chemical analysis on incoming materials and chemicals. TI and TI suppliers consider certain information to be proprietary, and thus CAS numbers and other limited information may not be available for release.

In no event shall TI's liability arising out of such information exceed the total purchase price of the TI part(s) at issue in this document sold by TI to Customer on an annual basis.

OTHER QUALIFIED VERSIONS OF TPS57114-EP :

- Automotive: [TPS57114-Q1](#)

NOTE: Qualified Version Definitions:

- Automotive - Q100 devices qualified for high-reliability automotive applications targeting zero defects

TAPE AND REEL INFORMATION

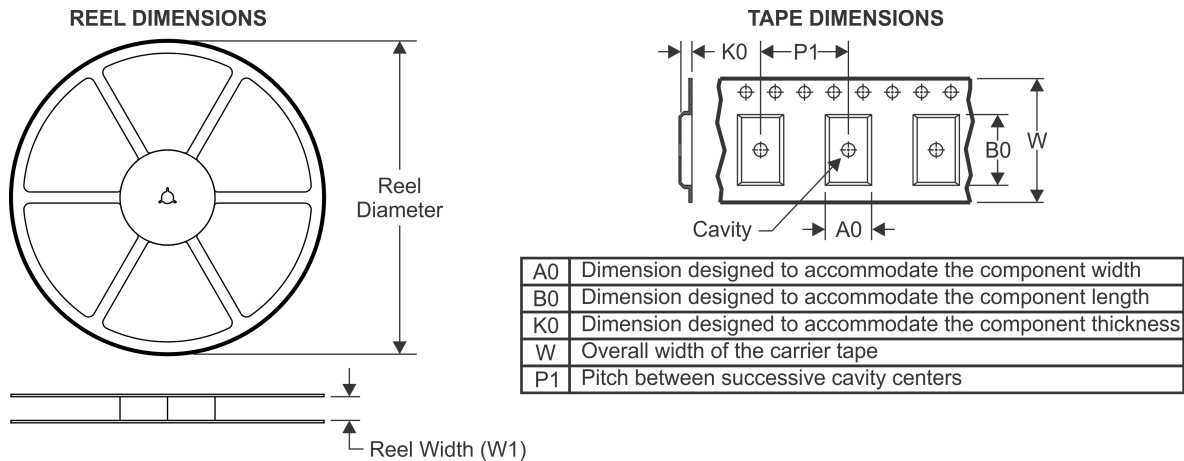

QUADRANT ASSIGNMENTS FOR PIN 1 ORIENTATION IN TAPE

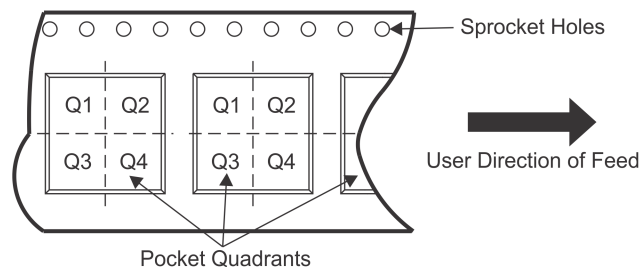

*All dimensions are nominal

Device	Package Type	Package Drawing	Pins	SPQ	Reel Diameter (mm)	Reel Width W1 (mm)	A0 (mm)	B0 (mm)	K0 (mm)	P1 (mm)	W (mm)	Pin1 Quadrant
TPS57114MRTETEP	WQFN	RTE	16	250	180.0	12.4	3.3	3.3	1.1	8.0	12.0	Q2

TAPE AND REEL BOX DIMENSIONS

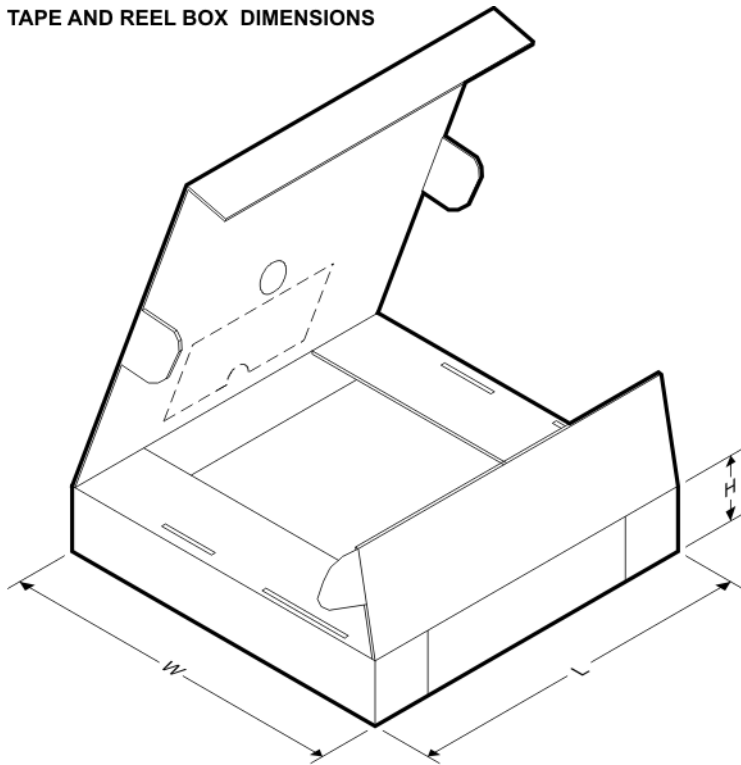

*All dimensions are nominal

Device	Package Type	Package Drawing	Pins	SPQ	Length (mm)	Width (mm)	Height (mm)
TPS57114MRTETEP	WQFN	RTE	16	250	210.0	185.0	35.0

MECHANICAL DATA

RTE (S-PWQFN-N16)

PLASTIC QUAD FLATPACK NO-LEAD

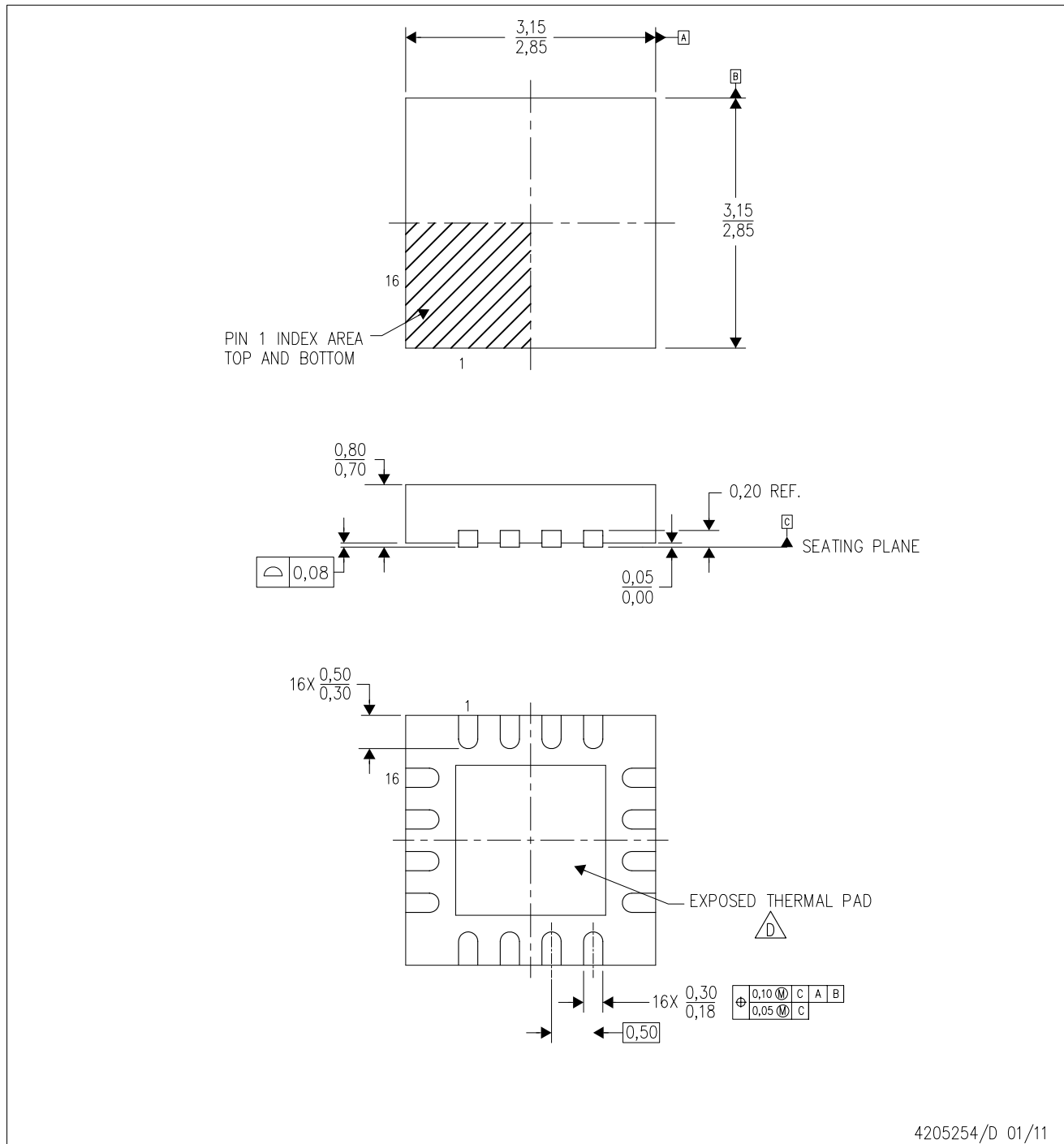

4205254/D 01/11

- NOTES:
- A. All linear dimensions are in millimeters. Dimensioning and tolerancing per ASME Y14.5M-1994.
 - B. This drawing is subject to change without notice.
 - C. Quad Flatpack, No-leads (QFN) package configuration.
 -  The package thermal pad must be soldered to the board for thermal and mechanical performance. See the Product Data Sheet for details regarding the exposed thermal pad dimensions.
 - E. Falls within JEDEC MO-220.

THERMAL INFORMATION

This package incorporates an exposed thermal pad that is designed to be attached directly to an external heatsink. The thermal pad must be soldered directly to the printed circuit board (PCB). After soldering, the PCB can be used as a heatsink. In addition, through the use of thermal vias, the thermal pad can be attached directly to the appropriate copper plane shown in the electrical schematic for the device, or alternatively, can be attached to a special heatsink structure designed into the PCB. This design optimizes the heat transfer from the integrated circuit (IC).

For information on the Quad Flatpack No-Lead (QFN) package and its advantages, refer to Application Report, QFN/SON PCB Attachment, Texas Instruments Literature No. SLUA271. This document is available at www.ti.com.

The exposed thermal pad dimensions for this package are shown in the following illustration.

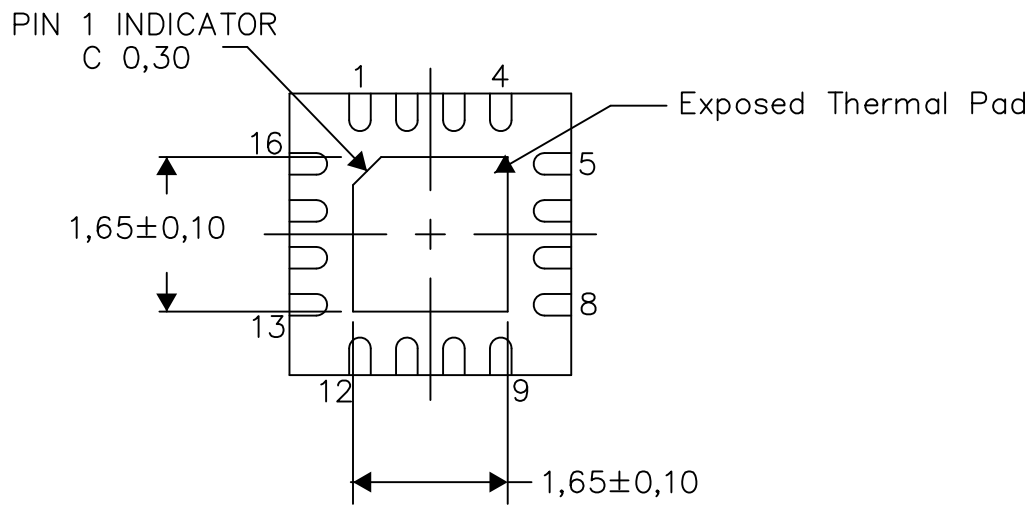

Bottom View

Exposed Thermal Pad Dimensions

4206446-4/U 08/15

NOTE: A. All linear dimensions are in millimeters

RTE (S-PWQFN-N16)

PLASTIC QUAD FLATPACK NO-LEAD

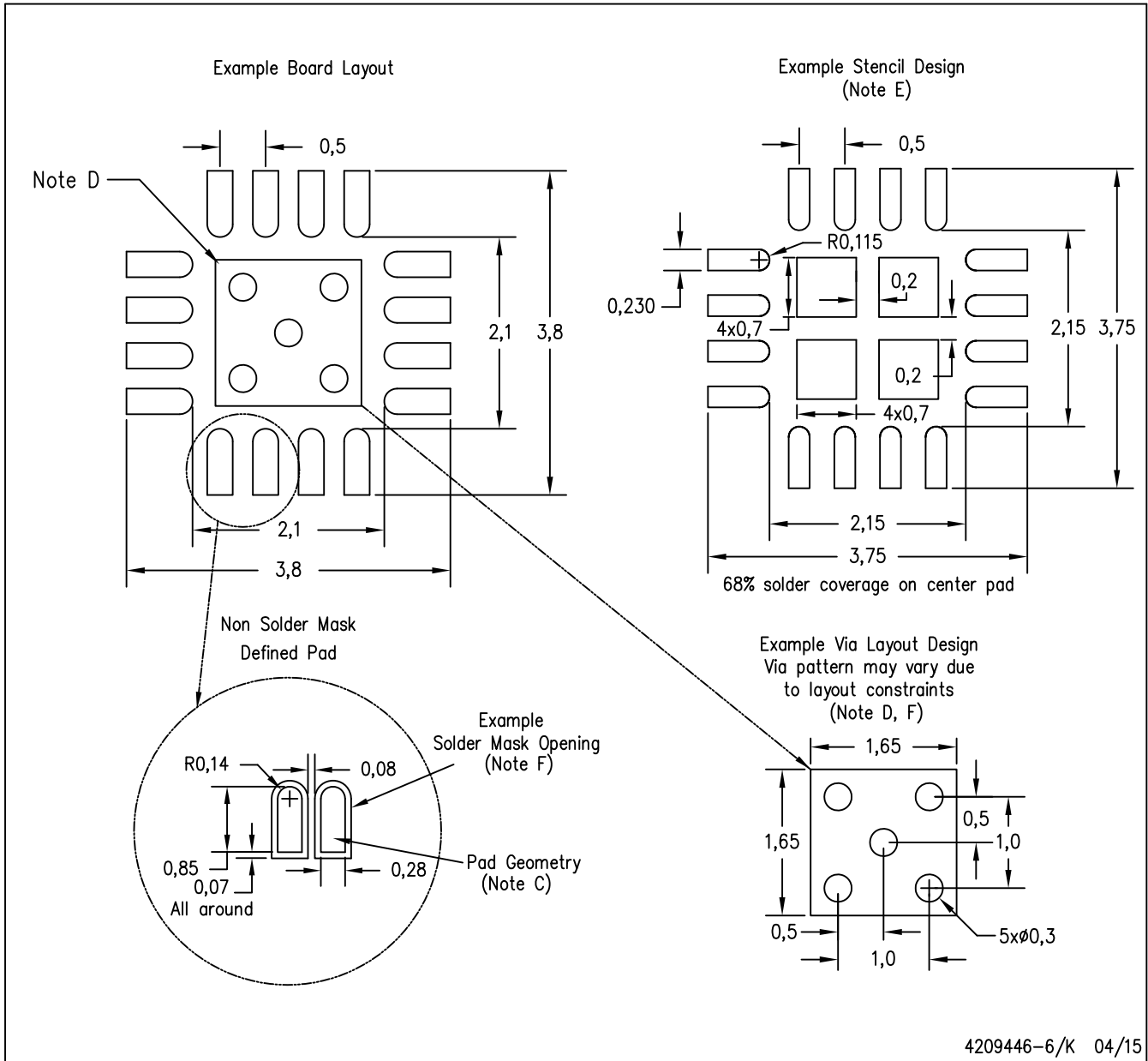

- NOTES:
- All linear dimensions are in millimeters.
 - This drawing is subject to change without notice.
 - Publication IPC-7351 is recommended for alternate designs.
 - This package is designed to be soldered to a thermal pad on the board. Refer to Application Note, Quad Flat-Pack Packages, Texas Instruments Literature No. SLUA271, and also the Product Data Sheets for specific thermal information, via requirements, and recommended board layout. These documents are available at www.ti.com <<http://www.ti.com>>.
 - Laser cutting apertures with trapezoidal walls and also rounding corners will offer better paste release. Customers should contact their board assembly site for stencil design recommendations. Refer to IPC 7525 for stencil design considerations.
 - Customers should contact their board fabrication site for minimum solder mask web tolerances between signal pads.

IMPORTANT NOTICE AND DISCLAIMER

TI PROVIDES TECHNICAL AND RELIABILITY DATA (INCLUDING DATASHEETS), DESIGN RESOURCES (INCLUDING REFERENCE DESIGNS), APPLICATION OR OTHER DESIGN ADVICE, WEB TOOLS, SAFETY INFORMATION, AND OTHER RESOURCES "AS IS" AND WITH ALL FAULTS, AND DISCLAIMS ALL WARRANTIES, EXPRESS AND IMPLIED, INCLUDING WITHOUT LIMITATION ANY IMPLIED WARRANTIES OF MERCHANTABILITY, FITNESS FOR A PARTICULAR PURPOSE OR NON-INFRINGEMENT OF THIRD PARTY INTELLECTUAL PROPERTY RIGHTS.

These resources are intended for skilled developers designing with TI products. You are solely responsible for (1) selecting the appropriate TI products for your application, (2) designing, validating and testing your application, and (3) ensuring your application meets applicable standards, and any other safety, security, or other requirements. These resources are subject to change without notice. TI grants you permission to use these resources only for development of an application that uses the TI products described in the resource. Other reproduction and display of these resources is prohibited. No license is granted to any other TI intellectual property right or to any third party intellectual property right. TI disclaims responsibility for, and you will fully indemnify TI and its representatives against, any claims, damages, costs, losses, and liabilities arising out of your use of these resources.

TI's products are provided subject to TI's Terms of Sale (www.ti.com/legal/termsofsale.html) or other applicable terms available either on ti.com or provided in conjunction with such TI products. TI's provision of these resources does not expand or otherwise alter TI's applicable warranties or warranty disclaimers for TI products.

Mailing Address: Texas Instruments, Post Office Box 655303, Dallas, Texas 75265
Copyright © 2020, Texas Instruments Incorporated