

Using the UCC21520EVM-286, UCC20520EVM-286, UCC21521CEVM-286, and UCC21530EVM-286

User's Guide



Literature Number: SLUUBG8B
June 2016–Revised November 2018

1	Trademarks	4
2	Introduction	4
3	Description	4
	3.1 Features	5
	3.2 I/O Description	5
	3.3 Jumpers (Shunt) Setting	6
4	Electrical Specifications	6
5	Test Summary	7
	5.1 Definitions	7
	5.2 Equipment	7
	5.3 Equipment Setup	7
6	Power-Up and Power-Down Procedure	10
	6.1 Power Up	10
	6.2 Power Down	10
7	Test Waveforms ($C_L=0pF$) With Different DT Configurations	11
	7.1 DT Connected to VCCI(J-DT Option B in)	11
	7.2 DT Pin Floating or Left Open (J-DT Option A in)	11
	7.3 DT Pin Connected to RDT (J-DT Option C in)	12
8	Schematic	13
9	Layout Diagrams	14
10	List of Materials	16
	Revision History	17

List of Figures

1	Jumpers Installation Position	8
2	Bench Setup Diagram and Configuration	9
3	Example Input and Output Waveforms (Channels 3 and 4 are PWM Inputs, Channels 1 and 2 are Outputs)	10
4	Overlap is Allowed When DT Connected to VCCI (Channels 3 and 4 are PWM Inputs, Channels 1 and 2 are Driver Outputs)	11
5	Test Waveforms if DT is Left Open (Channel 3 and 4 are PWM Inputs, and Channel 1 and 2 are Driver Outputs)	11
6	Test Waveforms if DT Connected to R_{DT} (Channel 3 and 4 is PWM Inputs, and Channel 1 and 2 is Driver Outputs)	12
7	UCC21520EVM-286 Schematic	13
8	Top Overlay	14
9	Top Layer	14
10	Bottom Layer	15
11	Bottom Overlay	15

List of Tables

1	Jumpers Setting	5
2	Jumpers Setting	6
3	UCC2x5xxEVM-286 Electrical Specifications	6
4	Two-Channel Function Generator Settings	8
5	Oscilloscope Settings	8
6	UCC2x5xxEVM-286 List of Materials	16

Using the UCC21520EVM-286, UCC20520EVM-286, UCC21521CEVM-286, and UCC21530EVM-286

UCC2x5xxEVM-286 evaluation modules are designed for evaluation of TI's 5.7-kV_{RMS} isolated dual-channel gate driver family with 4-A source and 6-A sink peak current for driving Si MOSFETs, IGBTs and WBG devices such as SiC and GaN transistors. This user's guide covers the UCC21520EVM-286, UCC20520EVM-286, UCC21521CEVM-286, and UCC21530EVM-286 used to evaluate the UCC21520DW, UCC20520DW, UCC21521CDW, and UCC21530DWK, respectively. To evaluate other Iso-Drivers in the UCC2x5xx family, TI recommends that the user read the data sheet thoroughly before switching the part in the EVMs covered by this user guide. In this user guide, the UCC21520EVM-286 evaluation module is shown as the primary example, and the key differences between the UCC21520EVM-286 and the UCC20520EVM-286, UCC21521CEVM-286, and UCC21530EVM-286 will be highlighted accordingly.

1 Trademarks

All trademarks are the property of their respective owners.

2 Introduction

Developed for high voltage applications where isolation and reliability is required, the UCC2x5xx delivers reinforced isolation of 5.7 kV_{RMS} and a surge immunity tested up to 12.8 kV along with a common-mode transient immunity (CMTI) greater than 100 V/ns. It has the industry's fastest propagation delay of 19 ns and the tightest channel-to-channel delay matching of less than 5 ns to enable high-switching frequency, high-power density, and efficiency.

The flexible, universal capability of the UCC2x5xx with up to 18-V VCCI and 25-V VDDA/VDDB allows the device to be used as a low-side, high-side, high-side/low-side, or half-bridge drivers with dual PWM input or single PWM input. With its integrated components, advanced protection features (UVLO, dead time and enable/disable), and optimized switching performances, the UCC2x5xx enables designers to build smaller, more robust designs for enterprise, telecom, automotive, and industrial applications with a faster time to market.

3 Description

The UCC2x5xx evaluation board has three independent screw terminal blocks for VCCI, VDDA, and VDDB. The 3-position headers with jumpers for all the key input signals, such as PWM INPUTs (INA, INB or PWM), dead time (DT) programming and enable/disable function (EN/DIS), allow designers to easily evaluate different protection functions. A variety of testing points also support most of the key feature probing of the UCC2x5xx. Moreover, the PCB layout is not only optimized with minimized loop area in each gate driver loop and power supply loop with bypassing capacitors, but the layout also supports high voltage test between the primary side and secondary side with 120-mil PCB board cutout. Importantly, the creepage distance between two output channels are maximized with bootstrap diode in footprint of TO252-2(DPAK), which facilitates high-voltage, half-bridge testing for a wide variety of power converter topologies. For detail device information, refer to [UCC21520DW](#), [UCC20520DW](#), [UCC21521CDW](#) and [UCC21530DWK](#) data sheets and [TI's Isolated gate driver solutions](#).

3.1 Features

- Evaluation module for the UCC21520DW, UCC20520DW, and UCC21521CDW in a wide body SOIC-16 (DW), along with the UCC21530DWK in wide body SOIC-14 (DWK) package
- 3-V to 18-V VCCI power supply range, and up to 25-V VDDA/VDDB power supply range
- 4-A and 6-A source/sink current capability
- 5.7-kV_{RMS} Isolation for 1 minute per UL 1577
- TTL/CMOS-compatible inputs
- Onboard trimmer potentiometer for dead-time programming
- 3-position header with for INA, INB, DT and enable/disable
- PCB layout optimized for power supply bypassing cap, gate driver loop
- PCB board cutout that facilitates high voltage isolation test between primary side and secondary side
- Maximized creepage distance between two output channels
- Support for half-bridge test with MOSFETs, IGBTs and SiC MOSFETs with connection to external power stage
- Testing points allows probing all the key pins of the UCC21520DW, UCC20520DW, UCC21521CDW, UCC21530DWK, and other wide-body ISO driver family parts.

3.2 I/O Description

Table 1. Jumpers Setting

PINS	DESCRIPTION
J1-1	VCCI positive input
J1-2	VCCI negative input
J2-1	VDDA negative input
J2-2	Driver A output
J2-3	VDDA positive input
J3-1	VDDB negative input
J3-2	Driver B output
J3-3	VDDB positive input
J-INA-1	Primary ground
J-INA-2	INA/PWM signal input
J-INA-3	Primary VCC
J-INB-1	Primary ground
J-INB-2	INB signal input
J-INB-3	Primary VCC
J-DIS-1 or J-DIS/EN-1	Primary VCC
J-DIS-2 or J-DIS/EN-2	Enable/Disable signal input
J-DIS-3 or J-DIS/EN-3	Primary ground
J-DT-1	Primary VCC
J-DT-2	Dead-time programming pin
J-DT-3	Connects to trimmer potentiometer

3.3 Jumpers (Shunt) Setting

Table 2. Jumpers Setting

JACK	Jumper Setting Options		FACTORY SETTING
J-INA	Option A:	Jumper not installed, INA/PWM signal provided by external signal and this pin is default low if left open	Option A
	Option B:	Jumper on J-INA-2 and J-INA-1 set INA low	
	Option C:	Jumper on J-INA-2 and J-INA-3 set INA high	
J-INB	Option A:	Jumper not installed, INB signal provided by external signal and this pin is default low if left open	Option A for UCC21520EVM-286, UCC21521CEM-286 and UCC21530EVM-286; Option D for UCC20520EVM-286
	Option B:	Jumper on J-INB-2 and J-INB-1 set INB low	
	Option C:	Jumper on J-INB-2 and J-INB-3 set INB high	
	Option D:	Header J-INB is not installed, and no connection on the device under test	
J-DIS or J-DIS/EN	Option A:	Jumper not installed, the devices under test are enabled when left open on enable/disable pin	Option C for UCC21520EVM-286 and UCC20520EVM-286; Option B for UCC21521CEVM-286 and UCC21530EVM-286
	Option B:	Jumper on J-DIS-2 and J-DIS-1 or J-DIS/EN-2 and J-DIS/EN-1	
	Option C:	Jumper on J-DIS-2 and J-DIS-3 or J-DIS/EN-2 and J-DIS/EN-3	
J-DT	Option A:	Jumper not installed, interlock with 8-ns dead time	Option B
	Option B:	Jumper on J-DT-2 and J-DT-1 allows driver output overlap or driver output follows PWM input for UCC21520EVM and UCC21521CEVM. The dead time will be around 0 ns in this option for UCC20520EVM	
	Option C:	Jumper on J-DT-2 and J-DT-3 set the dead time by DT (in ns) = R_{DT} (in k Ω) \times 10. For better noise immunity and dead-time matching, TI recommends to parallel a 2.2-nF or above bypassing capacitor from DT pin to GND.	

4 Electrical Specifications

Table 3. UCC2x5xxEVM-286 Electrical Specifications

DESCRIPTION		MIN	TYP	MAX	UNIT
V_{CCI}	Primary-side power supply	3		18	V
V_{DDA}, V_{DDB}	Driver output power supply for UCC21520EVM-286 and UCC20520EVM-286	9.2		25	V
	Driver output power supply for UCC21521CEM-286 and UCC21530EVM	14.7		25	V
F_S	Switching frequency	0		5	MHz
T_J	Operating junction temperature range	-40		125	°C

5 Test Summary

The UCC21520EVM-286 is used as the primary example for this section. Different Jumper settings, PWM signal input options and voltage source settings can be found in [Section 3](#) and [Section 4](#)

5.1 Definitions

This procedure details how to configure the UCC2x5xx evaluation board. Within this test procedure the following naming conventions are followed. Refer to the UCC21520EVM-286 Schematic in [Figure 7](#) for details.

V_{xx} : External voltage supply name.

$V_{(TPxx)}$: Voltage at test point TPxx. For example, $V(TP12)$ means the voltage at TP12.

$V_{(jxx)}$: Voltage at jack terminal Jxx.

$J_{xx(yy)}$: Terminal or pin yy of jack xx.

DMM: Digital multi-meters.

UUT: Unit under test

EVM: Evaluation module assembly, in this case the UUT assembly drawings have location for jumpers, test points and individual components.

5.2 Equipment

5.2.1 Power Supplies

Three DC power supply with voltage/current above 25 V/1 A (for example: Agilent E3634A)

5.2.2 Function Generators

One two-channel function generator over 20 MHz (for example: Tektronics AFG3252)

5.3 Equipment Setup

5.3.1 DC Power Supply Settings

- DC power supply #1
 - Voltage setting: 5 V
 - Current limit: 0.05 A
- DC power supply #2
 - Voltage setting: 12 V for UCC21520EVM and UCC20520EVM
 - Voltage setting: 15 V for UCC21521CEVM and UCC21530EVM
 - Current limit: 0.1 A
- DC power supply #3
 - Voltage setting: 12 V for UCC21520EVM and UCC20520EVM
 - Voltage setting: 15 V for UCC21521CEVM and UCC21530EVM
 - Current limit: 0.1 A

5.3.2 Digital Multi-Meter Settings

- Digital multi-meter #1
 - DC current measurement, auto-range.
- Digital multi-meter #2
 - DC current measurement, auto-range.

5.3.3 Two-Channel Function Generator Settings

Table 4. Two-Channel Function Generator Settings

	MODE	FREQUENCY	DUTY	DELAY	HIGH	LOW	OUTPUT IMPEDANCE
Channel A	Pulse	DC ~ 5 MHz	50%	0 ns	3.3 V	0 V	High Z
Channel B				100 ns			

5.3.4 Oscilloscope Setting

Table 5. Oscilloscope Settings

	BANDWIDTH	COUPLING	TERMINATION	SCALE SETTINGS	INVERTING
Channel A	500 MHz or above	DC	1 MΩ or automatic	10x or automatic	OFF
Channel B					

5.3.5 Jumper (Shunt) Settings

There are two jumpers (shunts) need to be installed before test:

1. Install shunt #1 for header *J-DIS* on pin 2-3 for the UCC21520EVM shown in [Figure 1](#). For the UCC20520EVM, UCC21521CEVM and the UCC21530EVM, refer to [Table 1](#). The UCC20520EVM is set as disable high on the DIS pin while the UCC21521CEM and UCC21530EVM is set as enable high on the EN pin.
2. Install shunt #2 on header *J-DT* on pin 1-2 as shown in [Figure 1](#).

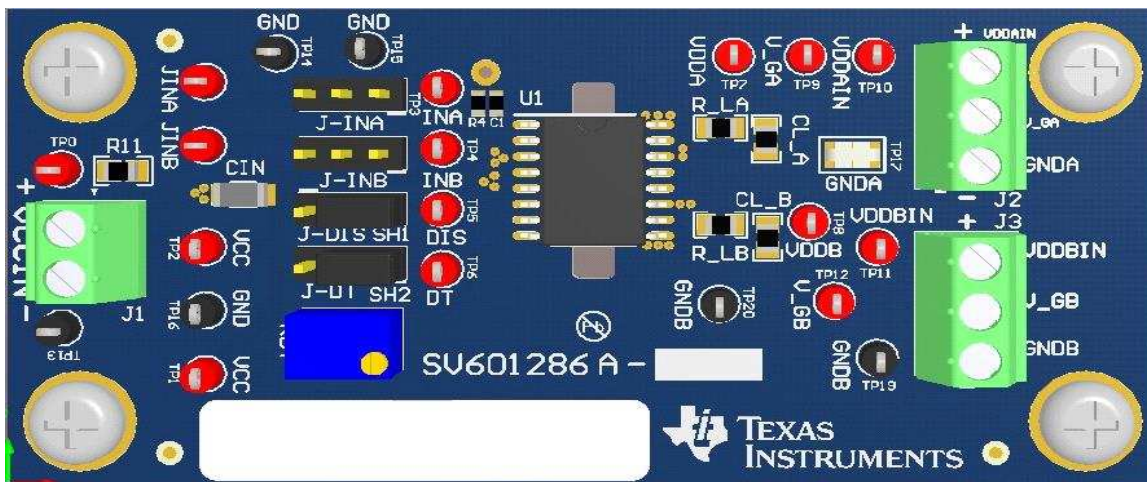

Figure 1. Jumpers Installation Position

5.3.6 Bench Setup Diagram

The current bench setup diagram includes the function generator and oscilloscope connections.

Follow the connection procedure below and use [Figure 2](#) as a reference:

- Make sure all the output of the function generator, voltage source are disabled before connection;
- Function generator channel-A channel applied on JINA ↔ TP14 as seen in [Figure 2](#);
- Function generator channel-B channel applied on JINB ↔ TP15 as seen in [Figure 2](#). For the UCC20520EVM, JINB, J-INB and TP15 are not installed because the UCC20520 is a single PWM input, dual-channel output Iso-Driver;
- Power supply #1: positive node applied on J1 pin-1 (or TP0), and negative node applied on J1 pin-2 (or TP13);
- Power supply #2: positive node connected to input of DMM #1 and DMM #1 output connected to J2 pin-3 (or TP10), negative node connected directly to J2 pin-1 (or TP17);
- Power supply #3: positive node connected to input of DMM #2 and DMM #2 output connected to J3 pin-3 (or TP 11), negative node connected directly to J3 pin-1 (or TP19);
- Oscilloscope channel-A probes TP9 ↔ TP17, smaller measurement loop is preferred;
- Oscilloscope channel-B probes TP12 ↔ TP19, smaller measurement loop is preferred;

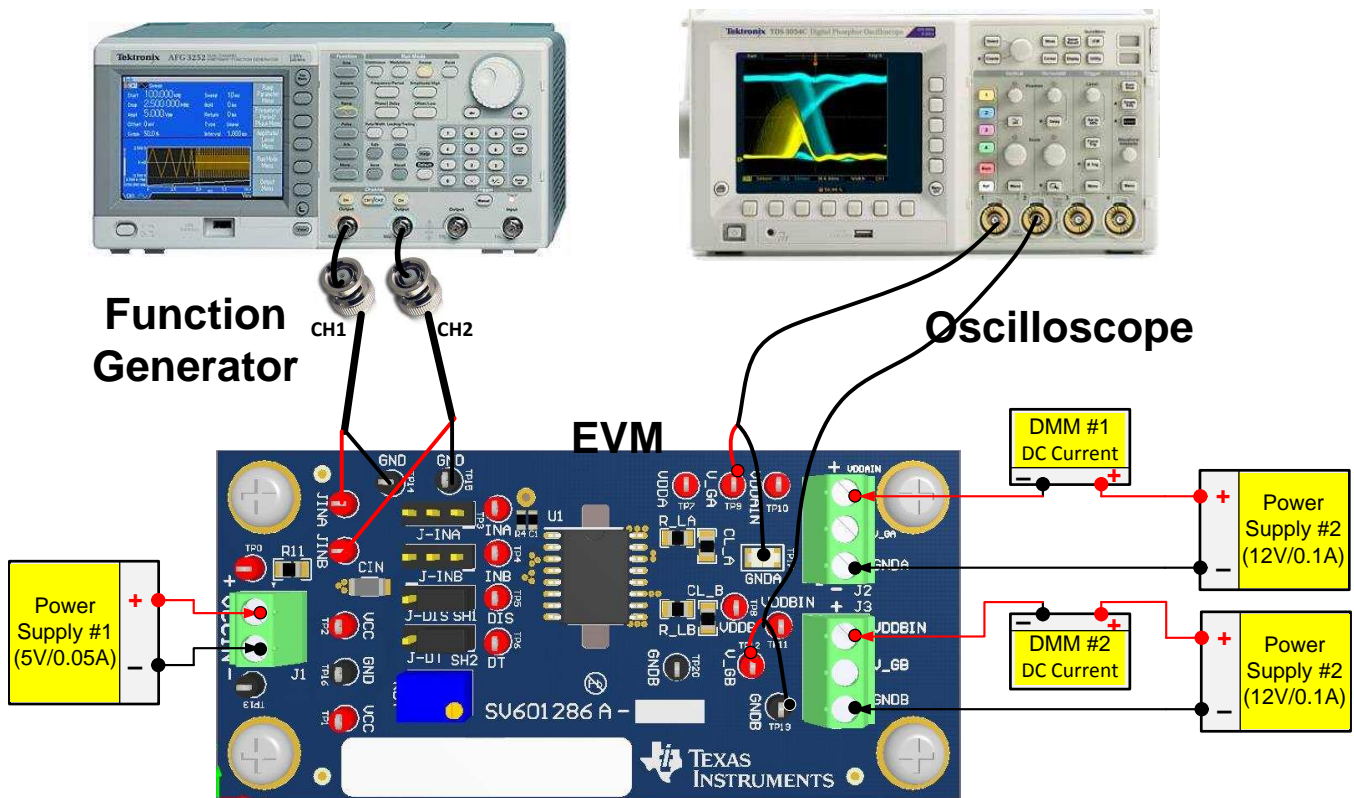

Figure 2. Bench Setup Diagram and Configuration

6 Power-Up and Power-Down Procedure

6.1 Power Up

1. Make sure that [Section 5.3.6](#) is implemented for setting up all the equipment before starting the power-up sequence. [Figure 3](#) can be used as a reference.
2. Enable supply #1;
3. Enable supply #2 and #3, the quiescent current on DMM1 and DMM2 ranges from 1 mA to approximately 3 mA if everything is set correctly;
4. Enable the function generator, two-channel outputs: channel-A and channel-B;
5. There will be:
 1. Stable pulse output on the channel-A and channel-B in the oscilloscope (refer to [Figure 3](#));
 2. Scope frequency measurement is the same with function generator output;
 3. DMM #1 and #2 read measurement results should be around 10 mA, ± 2 mA under no load conditions. For more information about operating current, refer to the [UCC21520 data sheet](#).

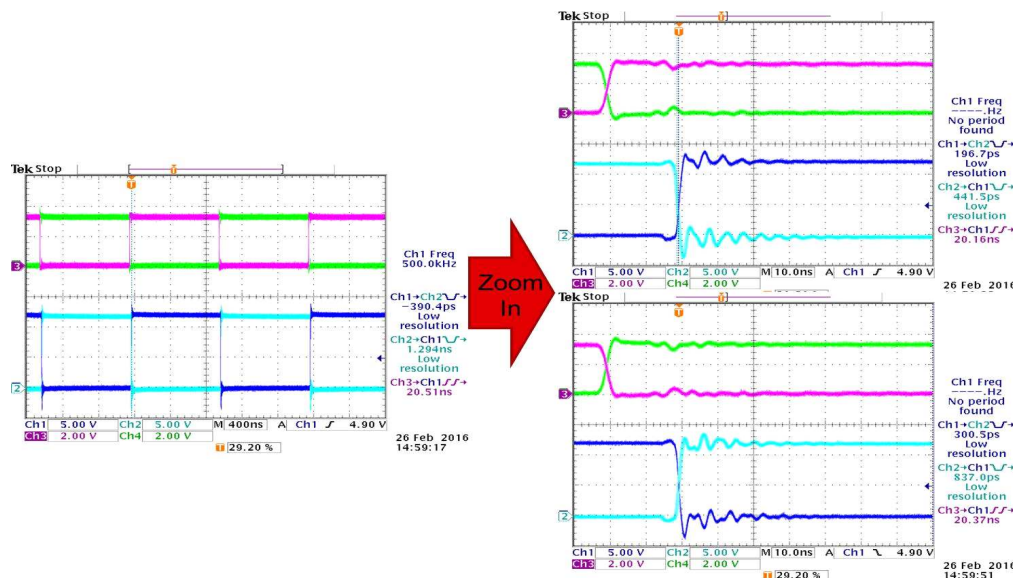

Figure 3. Example Input and Output Waveforms (Channels 3 and 4 are PWM Inputs, Channels 1 and 2 are Outputs)

6.2 Power Down

1. Disable function generator;
2. Disable power supply #2 and #3;
3. Disable power supply #1;
4. Disconnect cables and probes;

7 Test Waveforms ($C_L=0pF$) With Different DT Configurations

7.1 DT Connected to VCCI(J-DT Option B in Table 2)

The dead time (DT) between the outputs of the two channels is decided by inputs (see Figure 4). Overlap between two output channels is allowed. Figure 4 shows a waveform with overlapped operations.

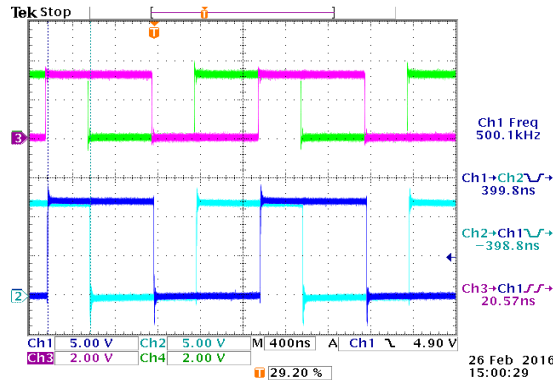

Figure 4. Overlap is Allowed When DT Connected to VCCI (Channels 3 and 4 are PWM Inputs, Channels 1 and 2 are Driver Outputs)

7.2 DT Pin Floating or Left Open (J-DT Option A in Table 2)

The dead time (DT) between the outputs of the two channels is around 8 ns, which is preset for interlock protections (see Figure 5).

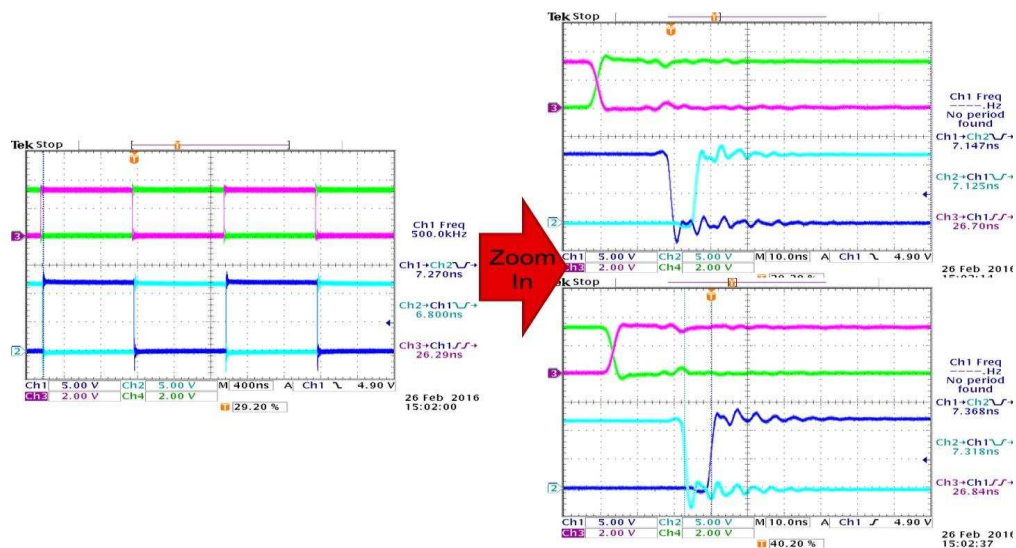

Figure 5. Test Waveforms if DT is Left Open (Channel 3 and 4 are PWM Inputs, and Channel 1 and 2 are Driver Outputs)

7.3 DT Pin Connected to RDT (J-DT Option C in Table 2)

The dead time (DT) between the outputs of the two channels is set according to: $DT \text{ (in ns)} = 10 \times R_{DT} \text{ (in k}\Omega\text{)}$.

The steady-state voltage at DT pin is around 0.8 V, and the DT pin current will be less than 10 μA when $R_{DT} = 100 \text{ k}\Omega$. Therefore, TI recommends to parallel a ceramic bypass capacitor (2.2 nF or above) with R_{DT} to achieve better noise immunity and better dead-time matching between two channels, especially when the dead time is larger than 300 ns. The major consideration is that the current through the R_{DT} is used to set the dead time, and this current decreases as R_{DT} increases. This bypass capacitor is not installed in the EVM, but the user can easily install it on the bottom layer where the R_{DT} is located.

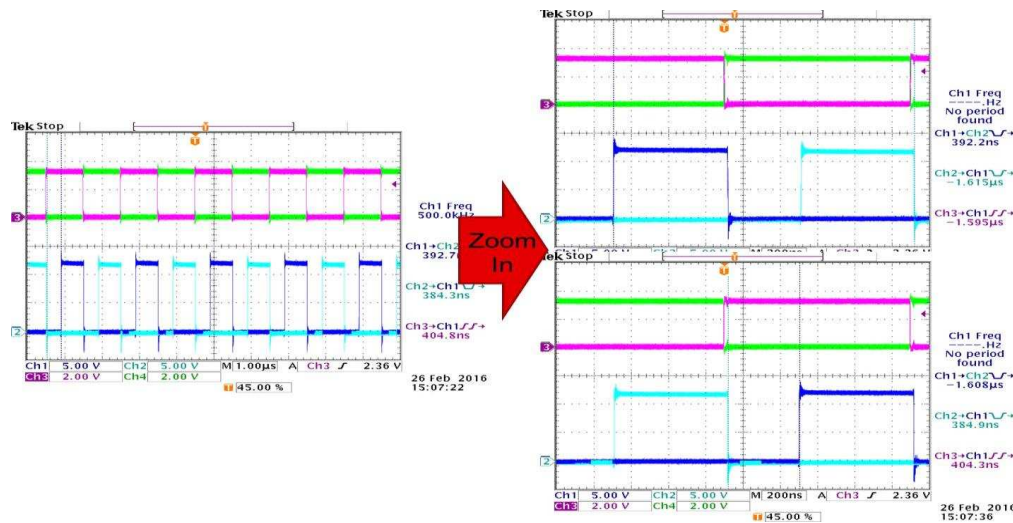

Figure 6. Test Waveforms if DT Connected to R_{DT}
(Channel 3 and 4 is PWM Inputs, and Channel 1 and 2 is Driver Outputs)

8 Schematic

Figure 7 only shows the schematic diagram for UCC21520EVM. The schematic diagrams for the UCC20520EVM, UCC21521CEVM, and UCC21530EVM are similar to Figure 7, with the exception that the device under test (U1) could be in one of the following driver ICs: UCC21520DW, UCC20520DW, UCC21521CDW, or UCC21530DWK.

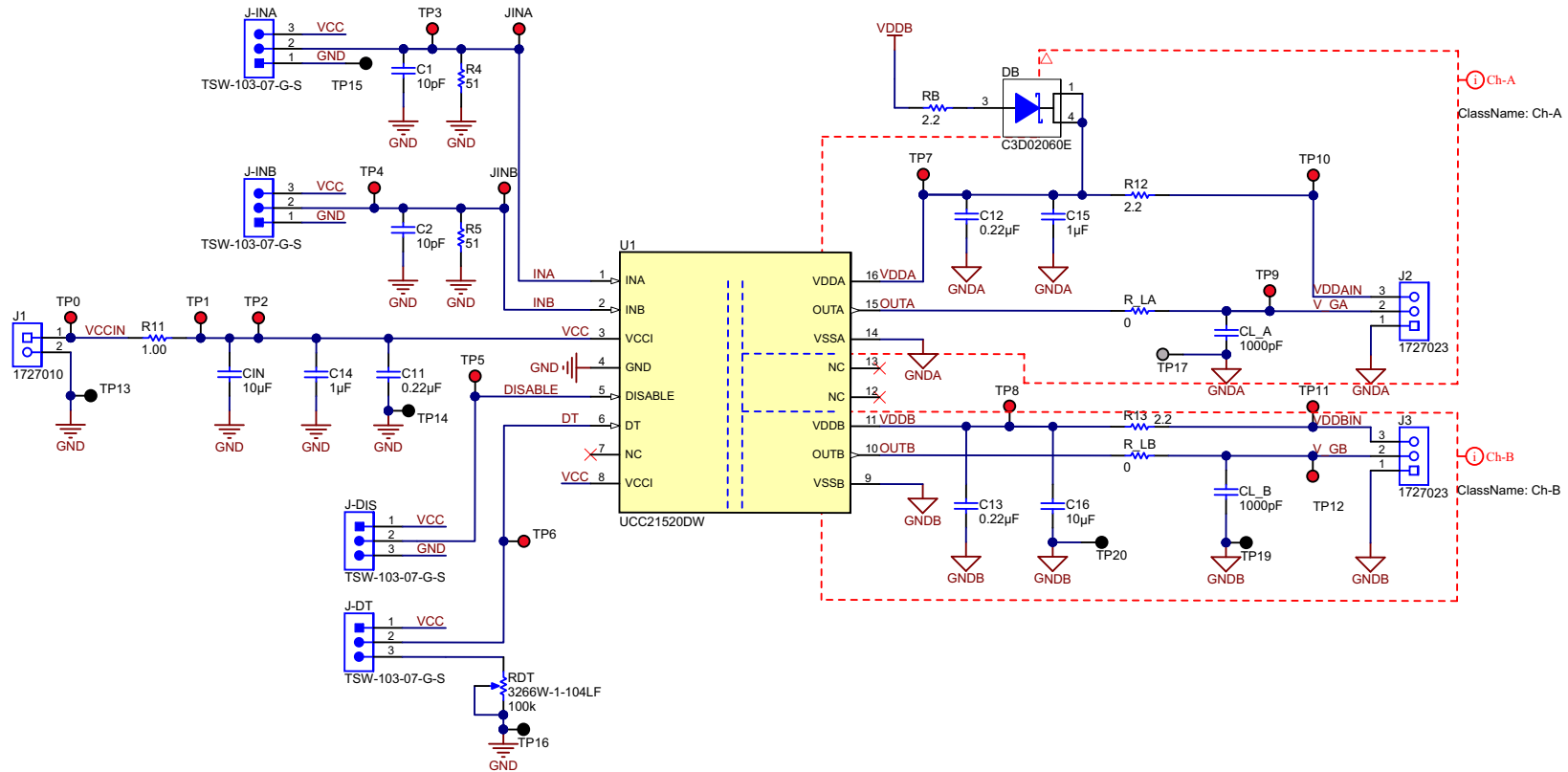

Figure 7. UCC21520EVM-286 Schematic

9 Layout Diagrams

The PCB layout information for UCC21520EVM is shown in Figure 8, Figure 9, Figure 10, and Figure 11. The layouts are the same for UCC20520EVM, UCC21521CEVM, and UCC21530EVM except for the labels that designate the EVM part number with the device under test.

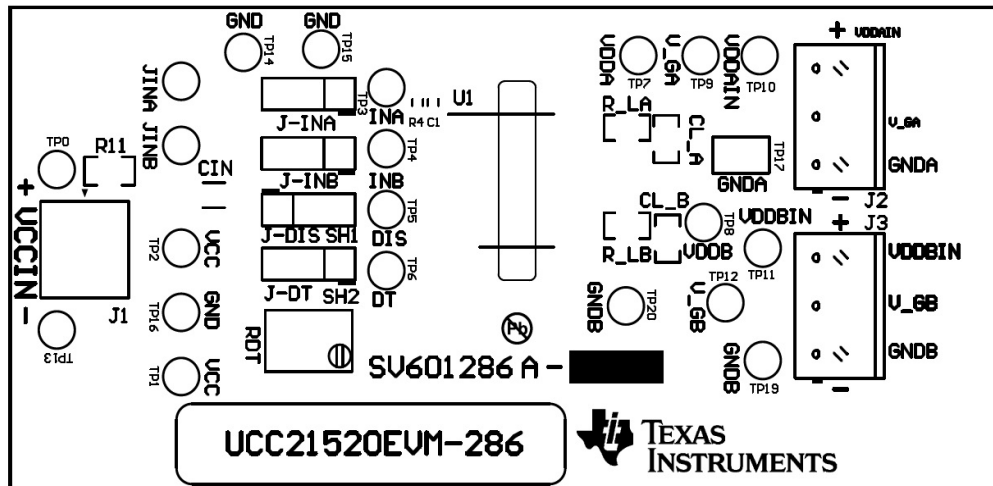

Figure 8. Top Overlay

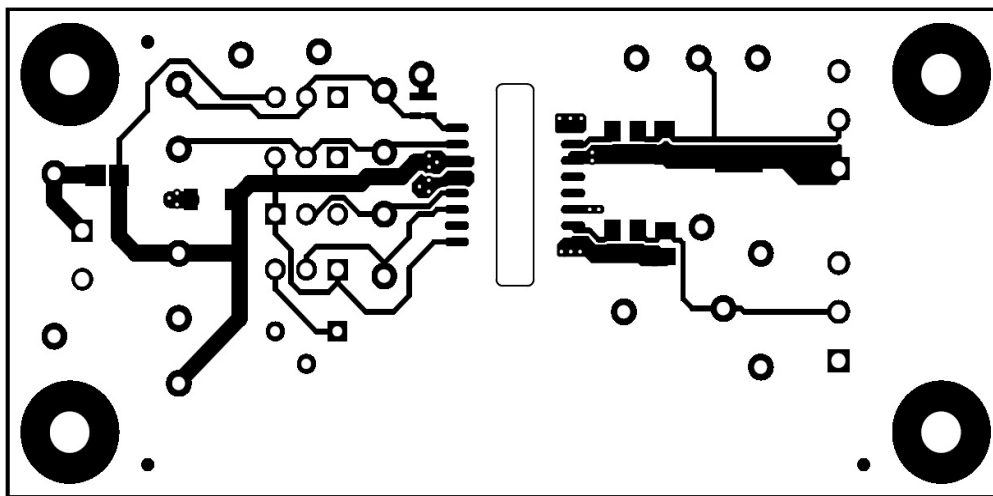

Figure 9. Top Layer

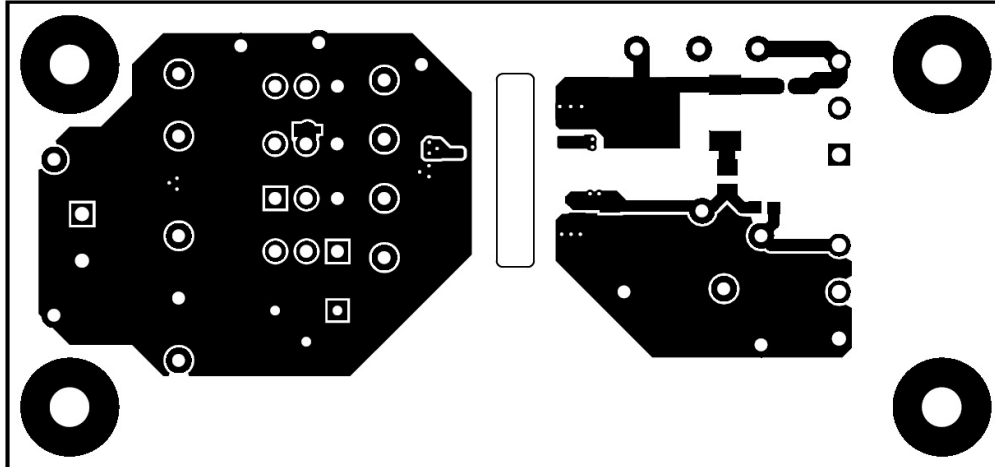

Figure 10. Bottom Layer

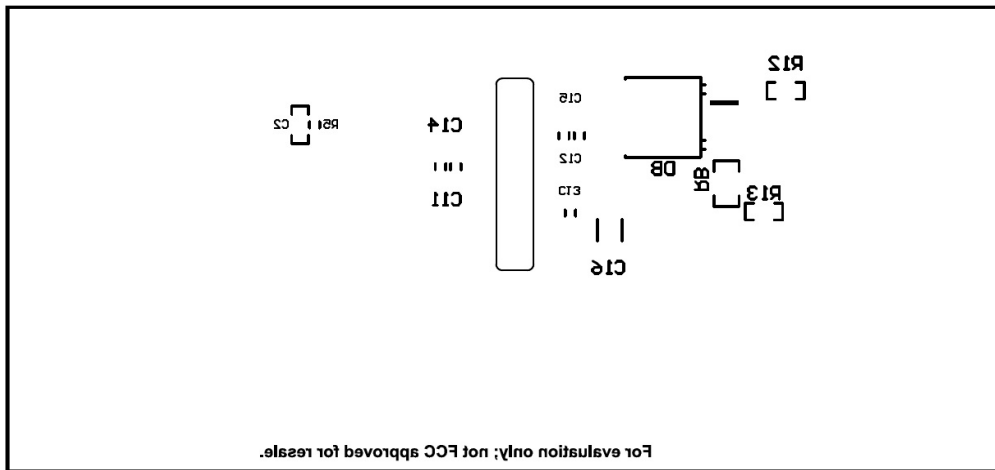

Figure 11. Bottom Overlay

10 List of Materials

Table 6. UCC2x5xxEVM-286 List of Materials

QTY	DES	DESCRIPTION	MANUFACTURE	PART NUMBER
2	C1, C2	Capacitor, ceramic, 10 pF, 50 V, $\pm 5\%$, C0G/NP0, 0603. C2 is not populated in UCC20520EVM.	Std	Std
3	C11, C12, C13	Capacitor, ceramic, 0.22 μ F, 50 V, $\pm 10\%$, X7R, 0603	Std	Std
2	C14, C15	Capacitor, ceramic, 1 μ F, 50 V, $\pm 10\%$, X5R, 0603	Std	Std
2	C16, CIN	Capacitor, ceramic, 10 μ F, 50 V, $\pm 10\%$, X5R, 1206_190	Std	Std
0	CL_A, CL_B	Capacitor, ceramic, 1000 pF, 50 V, $\pm 5\%$, C0G/NP0, 0805	Not Populated	Not Populated
0	DB	Diode, Schottky, 600 V, 8 A, DPAK	Not Populated	Not Populated
4	H1, H2, H3, H4	Machine screw, round, #4-40 x 1/4, nylon, philips panhead	Std	Std
4	H5, H6, H7, H8	Standoff, hex, 0.5"L #4-40 nylon	Std	Std
4	J-DIS, J-DT, J-INA, J-INB	Header, 100 mil, 3 x 1, gold, TH. J-INB is not installed in UCC20520EVM.	Std	Std
1	J1	Connection terminal block, 2 position, 3.81 mm, TH	Std	Std
2	J2, J3	Terminal block receptacle, 3 x 1, 3.81 mm, R/A, TH	Std	Std
15	JINA, JINB, TP0, TP1, TP2, TP3, TP4, TP5, TP6, TP7, TP8, TP9, TP10, TP11, TP12	Test point, miniature, red, TH. JINB and TP4 are not installed in UCC20520EVM.	Std	Std
0	R4, R5	Resistor, 51 Ω , 5%, 0.1 W, 0603	Not Populated	Not Populated
1	R11	Resistor, 1.00 Ω , 1%, 0.125 W, 0805	Std	Std
2	R12, R13	Resistor, 2.2 Ω , 5%, 0.1 W, 0603	Std	Std
1	RB	Resistor, 2.2 Ω , 5%, 0.125 W, 0805	Std	Std
2	R_LA, R_LB	Resistor, 0 Ω , 5%, 0.125 W, 0805	Std	Std
1	RDT	Trimmer, 100 k Ω , 0.25 W, TH	Std	Std
2	SH1, SH2	Shunt, 100 mil, flash gold, black	Std	Std
6	TP13, TP14, TP15, TP16, TP19, TP20	Test point, miniature, black, TH. TP15 is not installed in UCC20520EVM.	Std	Std
1	TP17	Test point, miniature, SMT	Std	Std
1	U1	UCC21520DW, UCC20520DW, UCC21521CDW and UCC21530DWK, 4-A and 6-A, 5-KV _{RMS} Dual Isolated-channel Universal Gate Driver, DW0016A and DWK0014 for UCC21530DWK	Texas Instruments	UCC21520DW, UCC20520DW, UCC21521CDW, or UCC21530DWK

Revision History

NOTE: Page numbers for previous revisions may differ from page numbers in the current version.

Changes from A Revision (November 2016) to B Revision Page

- Added device type to include the UCC21530EVM-286 Evaluation Module 4
-

Changes from Original (June 2016) to A Revision Page

- Added device type to include the UCC20520EVM-286 and UCC21521CEVM-286 Evaluation Modules 4
-

IMPORTANT NOTICE AND DISCLAIMER

TI PROVIDES TECHNICAL AND RELIABILITY DATA (INCLUDING DATASHEETS), DESIGN RESOURCES (INCLUDING REFERENCE DESIGNS), APPLICATION OR OTHER DESIGN ADVICE, WEB TOOLS, SAFETY INFORMATION, AND OTHER RESOURCES "AS IS" AND WITH ALL FAULTS, AND DISCLAIMS ALL WARRANTIES, EXPRESS AND IMPLIED, INCLUDING WITHOUT LIMITATION ANY IMPLIED WARRANTIES OF MERCHANTABILITY, FITNESS FOR A PARTICULAR PURPOSE OR NON-INFRINGEMENT OF THIRD PARTY INTELLECTUAL PROPERTY RIGHTS.

These resources are intended for skilled developers designing with TI products. You are solely responsible for (1) selecting the appropriate TI products for your application, (2) designing, validating and testing your application, and (3) ensuring your application meets applicable standards, and any other safety, security, or other requirements. These resources are subject to change without notice. TI grants you permission to use these resources only for development of an application that uses the TI products described in the resource. Other reproduction and display of these resources is prohibited. No license is granted to any other TI intellectual property right or to any third party intellectual property right. TI disclaims responsibility for, and you will fully indemnify TI and its representatives against, any claims, damages, costs, losses, and liabilities arising out of your use of these resources.

TI's products are provided subject to TI's Terms of Sale (www.ti.com/legal/termsofsale.html) or other applicable terms available either on ti.com or provided in conjunction with such TI products. TI's provision of these resources does not expand or otherwise alter TI's applicable warranties or warranty disclaimers for TI products.

Mailing Address: Texas Instruments, Post Office Box 655303, Dallas, Texas 75265
Copyright © 2018, Texas Instruments Incorporated