

# LTC2928

## Multichannel Power Supply Sequencer and Supervisor

### DESCRIPTION

Demonstration circuit 1029B is for evaluating the performance of the **LTC<sup>®</sup>2928** Multichannel Power Supply Sequencer and Supervisor.

The LTC2928 sequences and monitors up to four power channels in power-up and power-down, and it monitors those outputs in the steady state. Sequencing is accomplished by controlling the power supply enable inputs or N-channel MOSFET gates with the LTC2928 outputs. Supervisory functions include undervoltage and overvoltage monitoring, and capturing the output state information in the event of a system fault.

Inherent fault detection circuitry can detect:

- Stalled supplies (during sequencing)
- Supplies with the output voltage not satisfying the undervoltage or overvoltage conditions

- System controller command errors
- Externally commanded faults
- Sequencing faults

The board is populated with nineteen jumpers for selection of the LTC2928 operation options and with twelve LEDs for displaying:

- The undervoltage status in the steady state CMP1 (D5) – CMP4 (D8)
- The LTC2928 controlling outputs states EN1 (D1) – EN4 (D4)
- The state signals of the ON pin (#16), the  $\overline{\text{RST}}$  pin (#21), the  $\overline{\text{OV}}$  pin (#20), and the  $\overline{\text{FLT}}$  pin (#19).

**Design files for this circuit board are available at <http://www.linear.com/demo/DC1029B>**

LT, LT, LTC, LTM, Linear Technology and the Linear logo are registered trademarks of Linear Technology Corporation. All other trademarks are the property of their respective owners.

### PERFORMANCE SUMMARY Specifications are at $T_A = 25^\circ\text{C}$

SYMBOL	PARAMETER	CONDITIONS	MIN	TYP	MAX	UNITS
$V_{CC}$	$V_{CC}$ Input Supply Range		2.9		6.0	V
$V_{HVCC}$	$HV_{CC}$ Input Supply Range		7.2	12.0	16.5	V
$V_{ON}$	ON Threshold Voltage	$V_{ON}$ Rising	0.985	1.0	1.15	V
$V_{MON(TH)}$	Voltage Monitor Reset Threshold Voltage	$V_{SEL} = V_{CC}$	0.492	0.500	0.508	V
$V_{EN}$	Enable Pin Voltage Output in ON State		$V_{CC} + 4.5$	$V_{CC} + 5.5$	$V_{CC} + 6$	V
$I_{EN(UP)}$	Enable Pin Pull-Up Current	Enable Pin ON, $V_{EN} \leq V_{CC} + 4V$	-7.5	-10	-12.5	$\mu\text{A}$
$t_{STMR}$	Sequence Timer Period, STMR	$C_{STMR} = 0.022\mu\text{F}$	161	190	220	ms
$t_{PTMR}$	Power Good Timer Period	$C_{PTMR} = 2.2\mu\text{F}$	7.33	8.80	10.27	s
$t_{RTMR}$	Reset Timer	$C_{RTMR} = 0.047\mu\text{F}$	156.7	188.0	219.3	ms
V1	V1 Internal and External Input			2.5		V
V2	V2 Internal and External Input			1.5		V
V3	V3 Internal and External Input			1.8		V
V4	V4 Internal and External Input			3.3		V
TPV1	V1 Time Position			1		
TPV2	V2 Time Position			3		
TPV3	V3 Time Position			5		
TPV4	V4 Time Position			7		

## OPERATING PRINCIPLES

A single LTC2928 can control four positive supplies or three positive and one negative.

Each supply timing position in the sequence can be any one of eight available time positions. Refer to the data sheet for the external resistor values for setting the sequence time position.

Power is applied to the LTC2928 through either the  $V_{CC}$  pin (2.9V to 6V) or the  $HV_{CC}$  pin (7.2V to 16.5V).

Each one of the four enable outputs (EN1, EN2, EN3, EN4) provides a ( $V_{CC} + 4.5V$ ) signal to control a MOSFET gate or a power supply enable input.

The LTC2928 monitors four supply thresholds per supply (sequence-up, sequence-down, undervoltage, overvoltage) during a full LTC2928 operation cycle. A full operation cycle includes two transient phases (sequence-up and sequence-down) and one monitor (steady state) phase.

The time intervals between adjacent supplies' enable or disable signal is set by the value of the sequence timer capacitor with a timing scale factor of 8670ms/ $\mu$ F. The sequencing-up interval is equal to the sequencing-down interval.

The power good timer period defines the maximum time allowed by any input supply to reach its undervoltage threshold (in power-up) or drop to its sequencing-down threshold (in power-down). This period is set by a power good timer capacitor with a timing scale factor of 4000ms/ $\mu$ F.

During the sequence-up phase, supply monitor inputs are expected to cross their sequence-up threshold (which may be different from their undervoltage threshold). Any supply monitor input failing to cross its sequence-up threshold will stall the process and a sequence-up fault is generated.

During the sequence-down phase, supply monitor inputs are expected to cross their sequence-down threshold (which can be different from their undervoltage threshold) within the selected power good time. Any supply monitor input failing to cross its sequence-down threshold will stall the process and generate a sequence-down fault.

Refer to the LTC2928 data sheet for sequencing threshold selection by biasing the SQT1 and SQT2 pins.

## QUICK START PROCEDURE

For fast evaluation of LTC2928 performance, the board contains four low drop out regulators (LDO): LT1761ES-2.5, LT1761ES-1.5, LT1761ES-1.8, LT1761ES-3.3, and a push button with control circuitry for ON control signal generation. LDO outputs are +2.5V, +1.5V, 1.8V, and +3.3V. Each LDO has an enable input, and works as a power supply.

Demonstration circuit 1029B is easy to set up to evaluate the performance of the LTC2928 with the on-board supplies. Refer to Figure 1 for the proper circuit connection. For the load resistors R1, R2, R3, and R4 use 51Ω 1W resistors. Connect four scope probes to the load resistors R1, R2, R3, and R4.

Place jumpers in the following positions:

JP1 (OPERATION)	LAST
JP2 (ON)	INT_ON
JP3 (V1)	INT
JP4 (V3)	INT
JP5 (V2)	INT
JP6 (V4)	INT
JP7 (SQT1)	GND
JP8 (VSEL)	ALL POSITIVE
JP9 (RT1 Control)	TIME POSITION
JP10 (SQT2)	GND
JP11 (V1 POLARITY)	V1_POS
JP12 (MS1)	GND
JP13 (RT2 Control)	TIME POSITION
JP14 (OVA CONFIG)	32%
JP15 (MS2)	GND
JP16 (RT3 Control)	TIME POSITION
JP17 (V <sub>CC</sub> Select)	LOW V <sub>CC</sub>
JP18 (RDIS)	OPEN
JP19 (RT4 Control)	TIME POSITION

1. With the +5V power supply off, connect the supply to the 5V\_AUX and GND turrets.
2. Turn the +5V supply on and after that switch the ON control signal from low to high by pressing the button S1.
3. The power-up output voltages should correlate with the transient shown in Figure 3 (power-up phase). Acceptable tolerance in the sequence timing is ±20%.
4. Press the button PB (S1) to change the ON signal from high to low and observe the output voltages. The power-down output voltages should correlate with the transient shown in Figure 3. (power-down phase). Acceptable tolerance in the sequence timing is ±20%.
5. Turn the +5V power supply off and connect four external power supply terminals with DC1029 as shown in Figure 2. Use external power supplies with output voltages +2.5V, +1.5V, +1.8V, and +3.3V. Leave output loads as in previous experiments or replace them with 3W resistors 2.5Ω, 1.5Ω, 2Ω, and 3Ω accordingly to have current in each rail around 1A.
6. Change jumpers V1 (JP1), V2 (JP2), V3 (JP3), and V4 (JP4) positions from INT to EXT.
7. Turn-on all five power supplies. Pushing the button PB (S1) changes the ON signal from low to high and after the power-up transient completes, press PB (S1) a second time to initiate the power-down. The output voltage sequence timing should be similar to the timing with the internal power supplies.
8. The DC1029B could be used for the original customer design. Based on the sequence timing and threshold parameters define all the optional components' values, replace them on the board and verify design performance. Contact LTC Field Applications Engineers to get help in the designing or verifying your circuit with a special tool.

## QUICK START PROCEDURE

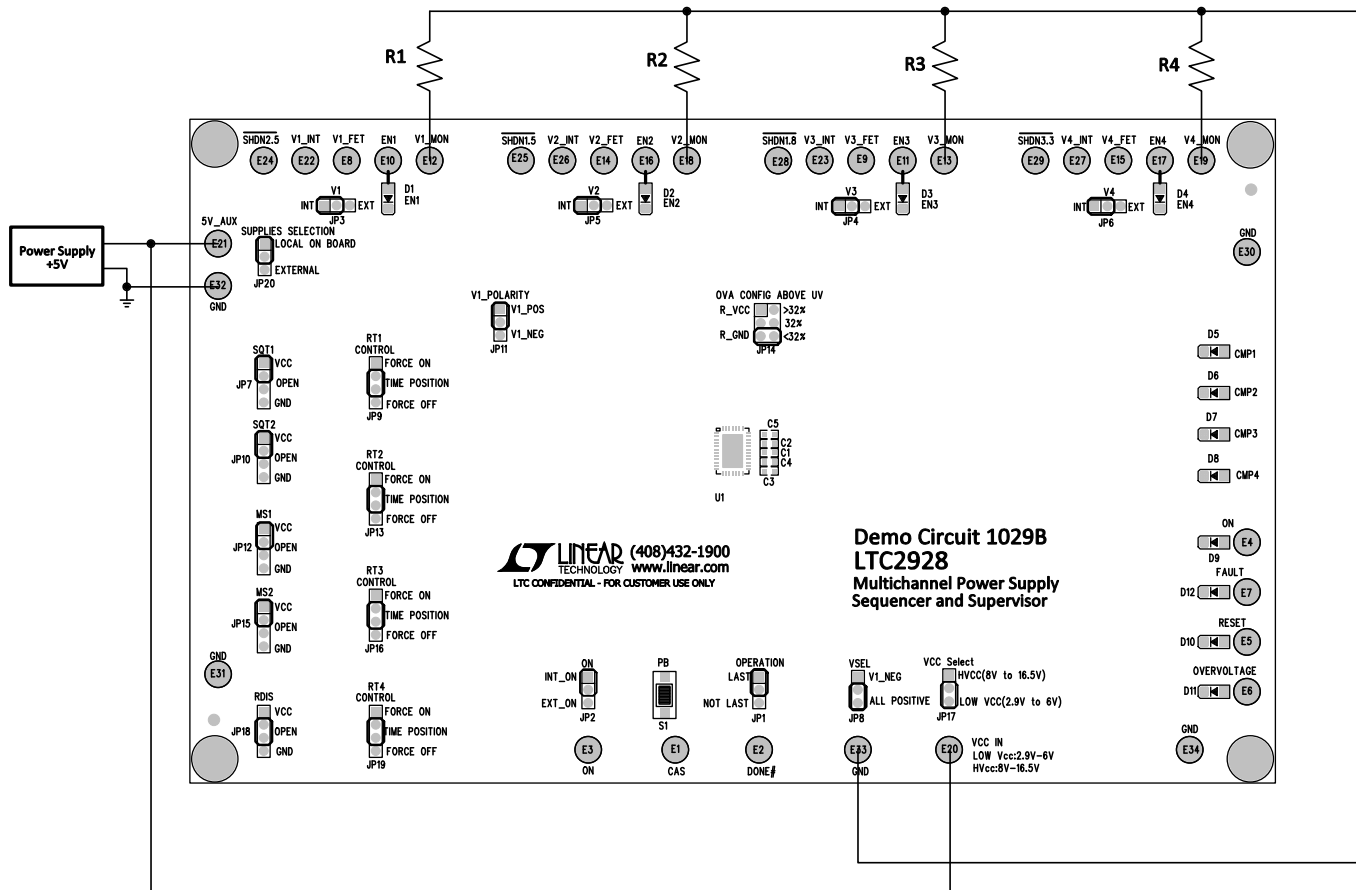

Figure 1. Demo Circuit 1029 Connections for Operation with Internal Supplies

QUICK START PROCEDURE

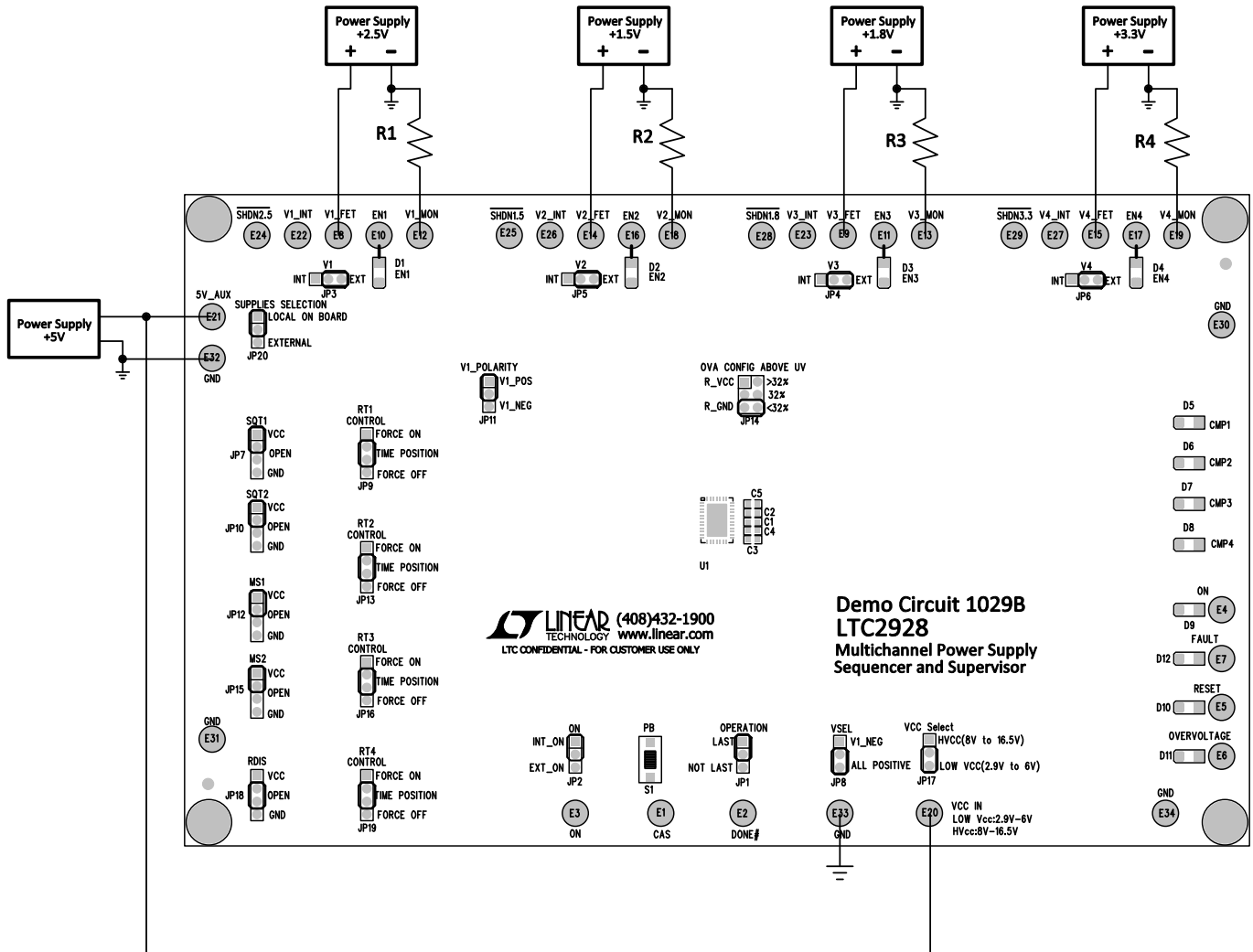

Figure 2. Demo Circuit 1029 Connections for Operation with External Supplies

**QUICK START PROCEDURE**

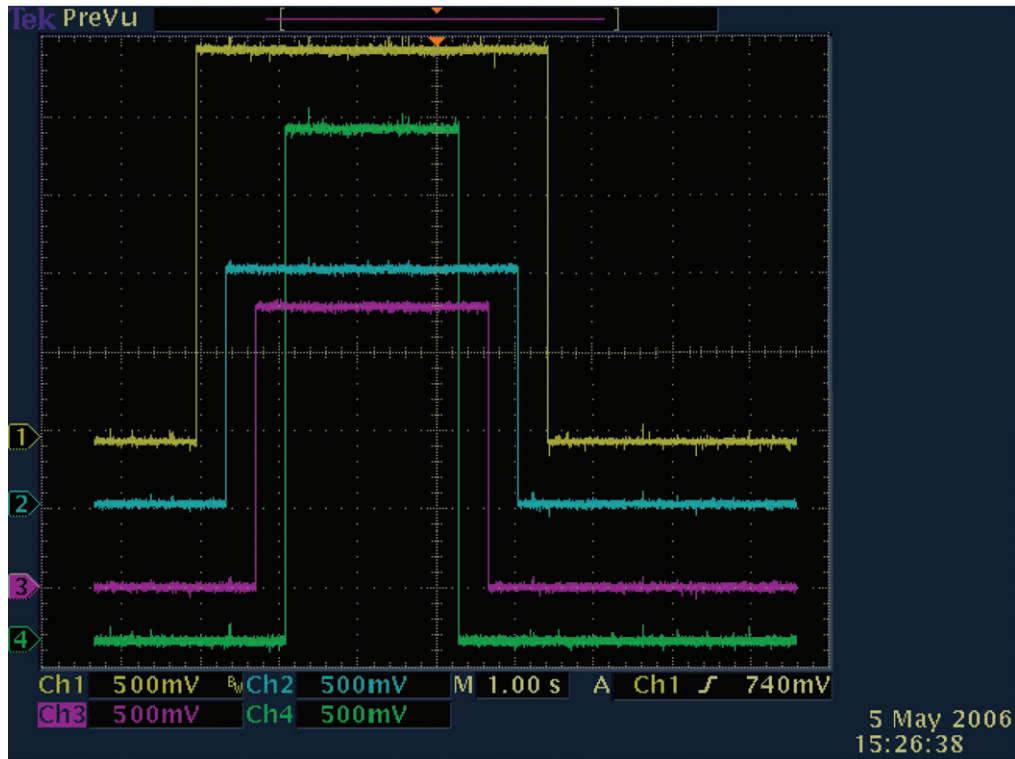
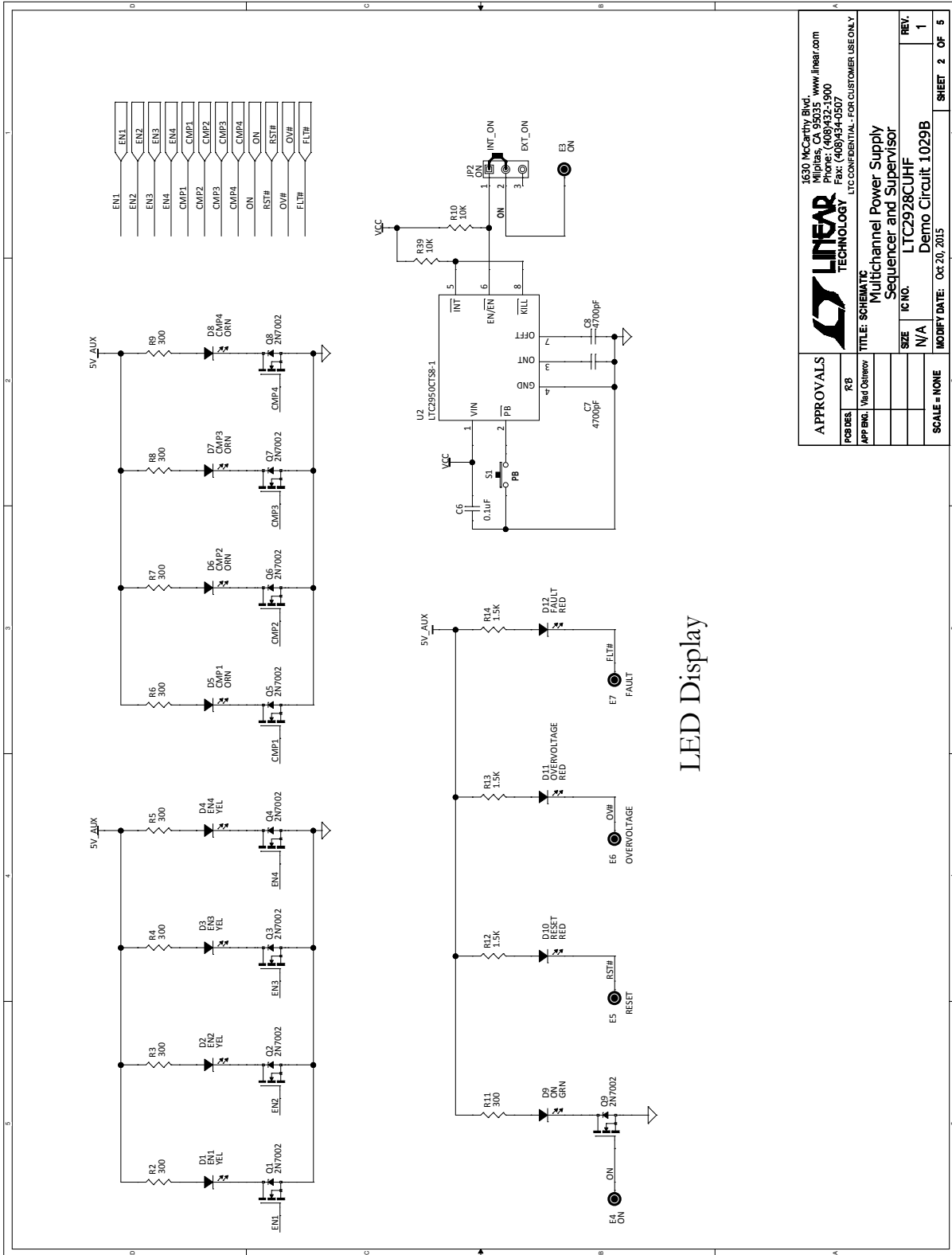

Figure 3. Power-Up and Power-Down Transients



# DEMO MANUAL DC1029B

## SCHEMATIC DIAGRAM



<b>APPROVALS</b>		1630 McCarthy Blvd. Milpitas, CA 95035 www.linear.com Phone: (408)432-1900 Fax: (408)434-0507 LTC CONFIDENTIAL - FOR CUSTOMER USE ONLY	
PBR/RES	F/S	<b>LINEAR TECHNOLOGY</b>	
APP ENG:	Wid Coloney	TITLE: SCHEMATIC Multichannel Power Supply Sequencer and Supervisor	
SIZE	N/A	IC NO. LTC2928CUHF	
SCALE	NONE	Demo Circuit 1029B	
		REV.	1
		MODIFY DATE:	Oct 20, 2015
		SHEET	2 OF 5

**SCHEMATIC DIAGRAM**

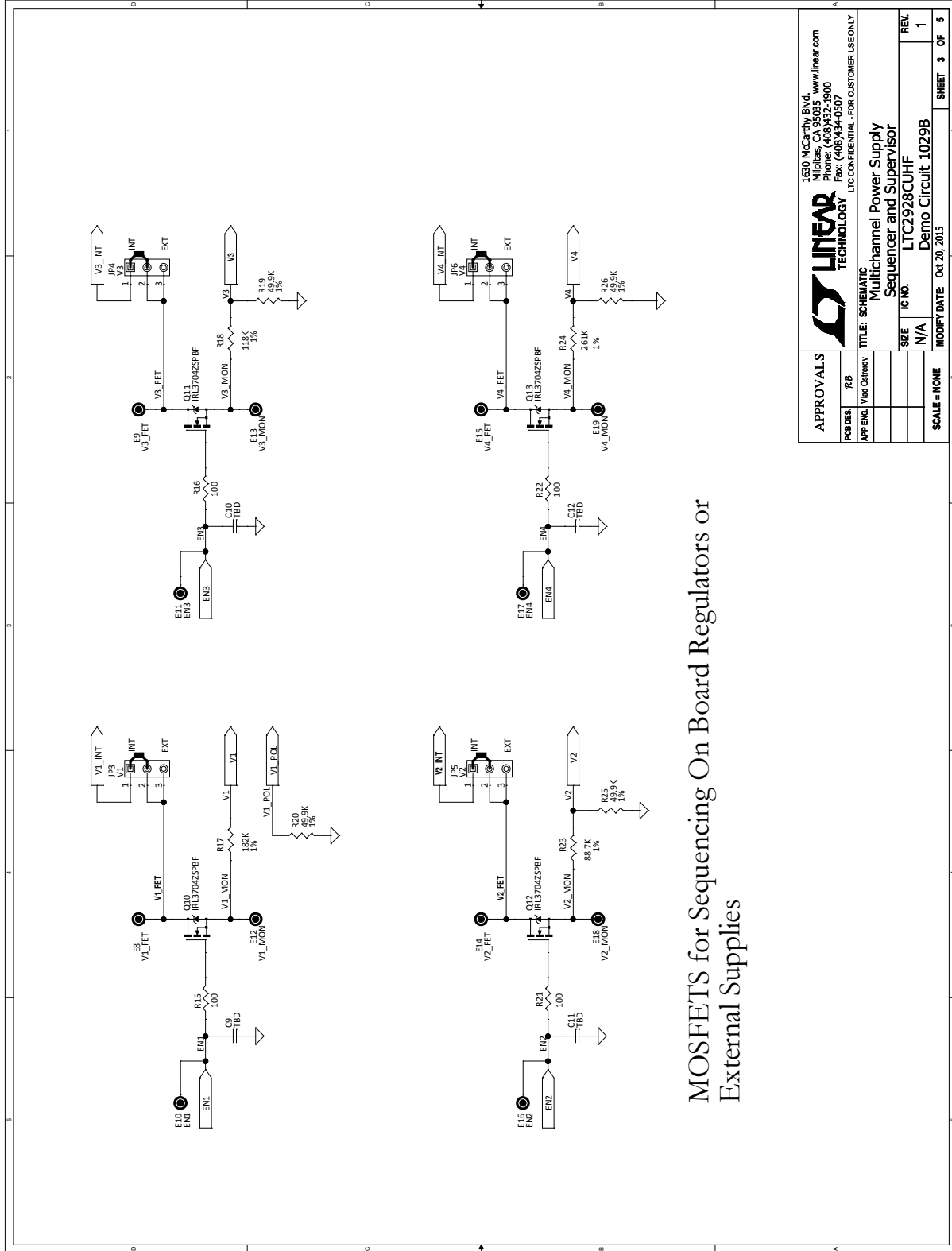

MOSFETS for Sequencing On Board Regulators or External Supplies

APPROVALS		1630 McCarthy Blvd. Milpitas, CA 95035 www.linear.com Phone: (408)432-1900 Fax: (408)434-0507 LTC CONFIDENTIAL - FOR CUSTOMER USE ONLY	
DESIGNER	RSB	LINEAR TECHNOLOGY	
APPENQ	Vijay Chintrev	TITLE: SCHEMATIC Multichannel Power Supply Sequencer and Supervisor	
SIZE	IC NO.	LTC2928QUHF	
SCALE	NONE	Demo Circuit: 1029B	
MODIFY DATE	Oct 20, 2015	REV. 1	
SHEET 3 OF 6			

## SCHEMATIC DIAGRAM

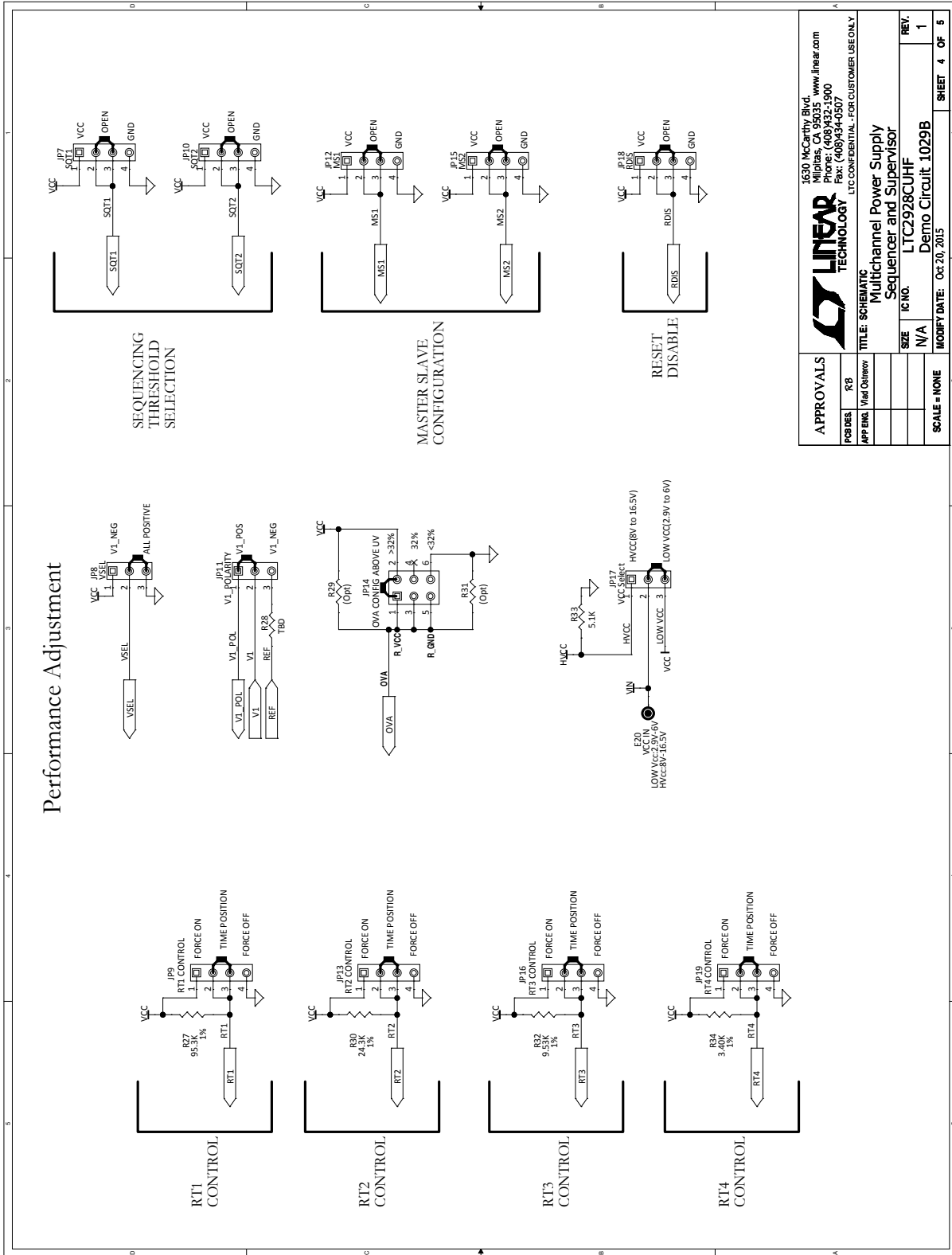

<b>APPROVALS</b>		1630 McCarthy Blvd. Milpitas, CA 95035 www.linear.com Phone: (408)932-1900 Fax: (408)934-0507	
DESIGN	RB	LTC CONFIDENTIAL - FOR CUSTOMER USE ONLY	
APP ENG	Vital Ostrovoy		
TITLE: SCHEMATIC		REV. 1	
MULTICHANNEL POWER SUPPLY		IC NO. LTC2928CUHF	
SEQUENCER AND SUPERVISOR		DEMO CIRCUIT 1029B	
SCALE = NONE		MODIFY DATE: Oct 20, 2015	
		SHEET 4 OF 5	

**SCHEMATIC DIAGRAM**

On Board LT1761ES Regulators

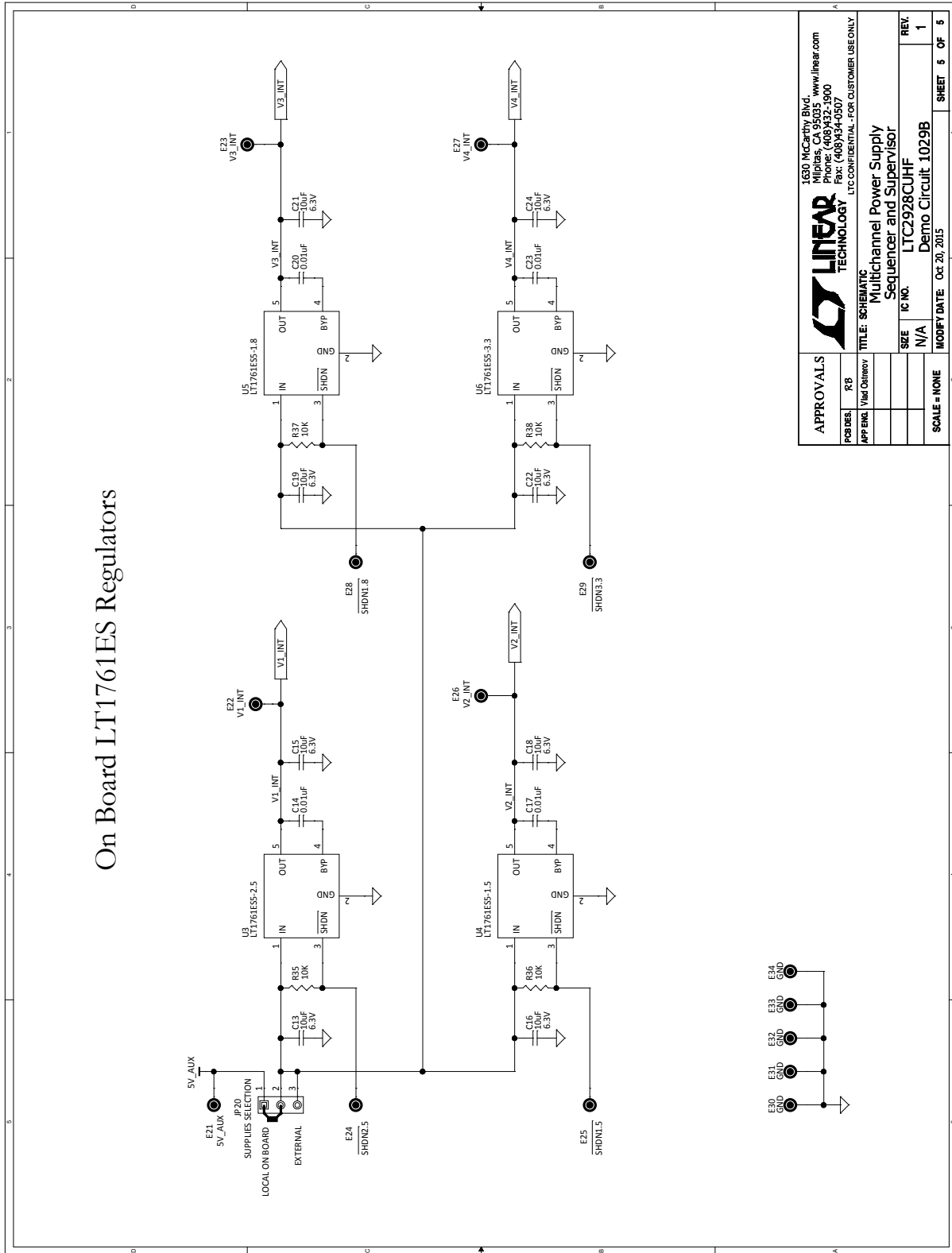

<b>APPROVALS</b>		1630 McCarthy Blvd. Milpitas, CA 95035 www.linear.com Phone: (408)432-1900 Fax: (408)434-0507 LTC CONFIDENTIAL - FOR CUSTOMER USE ONLY	
DESIGNER	RSB	<b>LINEAR TECHNOLOGY</b>	
APP'NG	Vlad Ostroev		
TITLE: SCHEMATIC		Multichannel Power Supply	
SEQUENCER AND SUPERVISOR		LTC2928QUHF	
SIZE	IC NO.	REV.	
N/A	N/A	1	
SCALE = NONE	MODIFY DATE	Oct 20, 2015	
		SHEET 5 OF 6	

# DEMO MANUAL DC1029B

---

## DEMONSTRATION BOARD IMPORTANT NOTICE

Linear Technology Corporation (LTC) provides the enclosed product(s) under the following **AS IS** conditions:

This demonstration board (DEMO BOARD) kit being sold or provided by Linear Technology is intended for use for **ENGINEERING DEVELOPMENT OR EVALUATION PURPOSES ONLY** and is not provided by LTC for commercial use. As such, the DEMO BOARD herein may not be complete in terms of required design-, marketing-, and/or manufacturing-related protective considerations, including but not limited to product safety measures typically found in finished commercial goods. As a prototype, this product does not fall within the scope of the European Union directive on electromagnetic compatibility and therefore may or may not meet the technical requirements of the directive, or other regulations.

If this evaluation kit does not meet the specifications recited in the DEMO BOARD manual the kit may be returned within 30 days from the date of delivery for a full refund. **THE FOREGOING WARRANTY IS THE EXCLUSIVE WARRANTY MADE BY THE SELLER TO BUYER AND IS IN LIEU OF ALL OTHER WARRANTIES, EXPRESSED, IMPLIED, OR STATUTORY, INCLUDING ANY WARRANTY OF MERCHANTABILITY OR FITNESS FOR ANY PARTICULAR PURPOSE. EXCEPT TO THE EXTENT OF THIS INDEMNITY, NEITHER PARTY SHALL BE LIABLE TO THE OTHER FOR ANY INDIRECT, SPECIAL, INCIDENTAL, OR CONSEQUENTIAL DAMAGES.**

The user assumes all responsibility and liability for proper and safe handling of the goods. Further, the user releases LTC from all claims arising from the handling or use of the goods. Due to the open construction of the product, it is the user's responsibility to take any and all appropriate precautions with regard to electrostatic discharge. Also be aware that the products herein may not be regulatory compliant or agency certified (FCC, UL, CE, etc.).

No License is granted under any patent right or other intellectual property whatsoever. **LTC assumes no liability for applications assistance, customer product design, software performance, or infringement of patents or any other intellectual property rights of any kind.**

LTC currently services a variety of customers for products around the world, and therefore this transaction **is not exclusive**.

**Please read the DEMO BOARD manual prior to handling the product.** Persons handling this product must have electronics training and observe good laboratory practice standards. **Common sense is encouraged.**

This notice contains important safety information about temperatures and voltages. For further safety concerns, please contact a LTC application engineer.

Mailing Address:

Linear Technology  
1630 McCarthy Blvd.  
Milpitas, CA 95035

Copyright © 2004, Linear Technology Corporation