

DACx1001 20-Bit, 18-Bit, and 16-Bit, Low-Noise, Ultra-Low Harmonic Distortion, Fast-Settling, High-Voltage Output, Digital-to-Analog Converters (DACs)

1 Features

- 20-bit monotonic: 1-LSB DNL (max)
- Integral linearity: 4-LSB INL (max)
- Low noise: $7\text{ nV}/\sqrt{\text{Hz}}$
- Code independent low glitch: 1 nV-s
- Excellent THD: -105 dB at 1-kHz f_{OUT}
- Fast settling: 1 μs
- Flexible output ranges: V_{REFPF} to V_{REFNF}
- Integrated, precision feedback resistors
- 50-MHz, 4-wire SPI-compatible interface
 - Readback
 - Daisy-chain
- Temperature range: -40°C to $+125^{\circ}\text{C}$
- Package: 48-pin TQFP

2 Applications

- [Lab and field instrumentation](#)
- [Spectrometer](#)
- [Analog output module](#)
- [Battery Test](#)
- [Semiconductor test](#)
- [Arbitrary waveform generator \(AWG\)](#)
- [MRI](#)
- [X-ray systems](#)
- [Professional audio amplifier \(rack mount\)](#)

3 Description

The 20-bit DAC11001A, 18-bit DAC91001, and 16-bit DAC81001 (DACx1001) are highly accurate, low-noise, voltage-output, single-channel, digital-to-analog converters (DACs). The DACx1001 are specified monotonic by design, and offer excellent linearity of less than 4 LSB (max) across all ranges.

The unbuffered voltage output offers low noise performance ($7\text{ nV}/\sqrt{\text{Hz}}$) in combination with a fast settling time (1 μs), making this device an excellent choice for low-noise, fast control-loop, and waveform generation applications. The DACx1001 integrates an enhanced deglitch circuit with code-independent ultra-low glitch (1 nV-s) to enable clean waveform ramps with ultra-low total harmonic distortion (THD).

The DACx1001 devices incorporate a power-on-reset circuit so that the DAC powers with known values in the registers. With external references, DAC output ranges from V_{REFPF} to V_{REFNF} can be achieved, including asymmetric output ranges.

The DACx1001 use a versatile 4-wire serial interface that operates at clock rates of up to 50 MHz. The DACx1001 is specified over the industrial temperature range of -40°C to $+125^{\circ}\text{C}$.

Device Information⁽¹⁾

PART NUMBER	PACKAGE	BODY SIZE (NOM)
DAC11001A	TQFP (48)	7.00 mm x 7.00 mm
DAC91001		
DAC81001		

(1) For all available packages, see the package option addendum at the end of the data sheet.

Functional Block Diagram

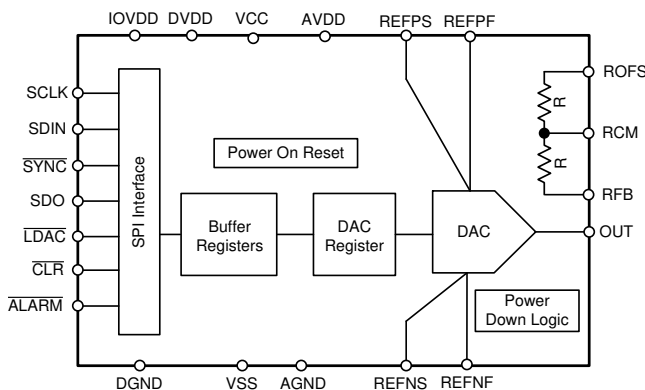

High-Precision, Control-Loop Circuit

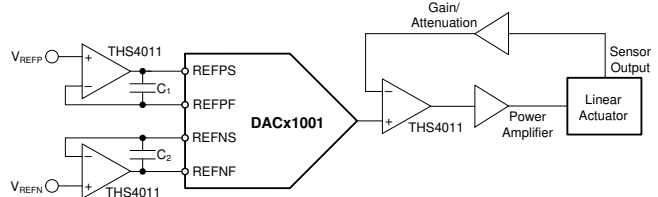

Table of Contents

1 Features	1	8.4 Device Functional Modes	26
2 Applications	1	8.5 Programming	27
3 Description	1	8.6 Register Map	29
4 Revision History	2	9 Application and Implementation	34
5 Device Comparison Table	3	9.1 Application Information	34
6 Pin Configuration and Functions	3	9.2 Typical Application	34
7 Specifications	5	9.3 System Examples	39
7.1 Absolute Maximum Ratings	5	9.4 What to Do and What Not to Do	42
7.2 ESD Ratings	5	9.5 Initialization Set Up	42
7.3 Recommended Operating Conditions	6	10 Power Supply Recommendations	43
7.4 Thermal Information Package	6	10.1 Power-Supply Sequencing	45
7.5 Electrical Characteristics	7	11 Layout	46
7.6 Timing Requirements: Write, $4.5\text{ V} \leq \text{DV}_{\text{DD}} \leq 5.5\text{ V}$	11	11.1 Layout Guidelines	46
7.7 Timing Requirements: Write, $2.7\text{ V} \leq \text{DV}_{\text{DD}} < 4.5\text{ V}$	12	11.2 Layout Example	46
7.8 Timing Requirements: Read and Daisy-Chain Write, $4.5\text{ V} \leq \text{DV}_{\text{DD}} \leq 5.5\text{ V}$	13	12 Device and Documentation Support	47
7.9 Timing Requirements: Read and Daisy-Chain Write, $2.7\text{ V} \leq \text{DV}_{\text{DD}} < 4.5\text{ V}$	14	12.1 Device Support	47
7.10 Typical Characteristics	16	12.2 Documentation Support	47
8 Detailed Description	23	12.3 Related Links	47
8.1 Overview	23	12.4 Receiving Notification of Documentation Updates	47
8.2 Functional Block Diagram	23	12.5 Support Resources	47
8.3 Feature Description	23	12.6 Trademarks	47
		12.7 Electrostatic Discharge Caution	47
		12.8 Glossary	47
		13 Mechanical, Packaging, and Orderable Information	48

4 Revision History

Changes from Revision A (December 2019) to Revision B	Page
• Changed DAC81001 and DAC91001 from advanced information (preview) to production data (active), and added associated content	1
• Changed relative accuracy drift over time typical value from 0.1 LSB to ± 0.1 LSB in <i>Electrical Characteristics</i> table	7
• Added output voltage drift over time parameter to the <i>Electrical Characteristics</i> table	8
• Changed Figure 42, DAC Output Noise: 0.1 Hz to 10 Hz	22

Changes from Original (October 2019) to Revision A	Page
• Changed DAC11001A device from advanced information (preview) to production data (active)	1

5 Device Comparison Table

DEVICE	RESOLUTION
DAC11001A	20-bit
DAC91001	18-bit
DAC81001	16-bit

6 Pin Configuration and Functions

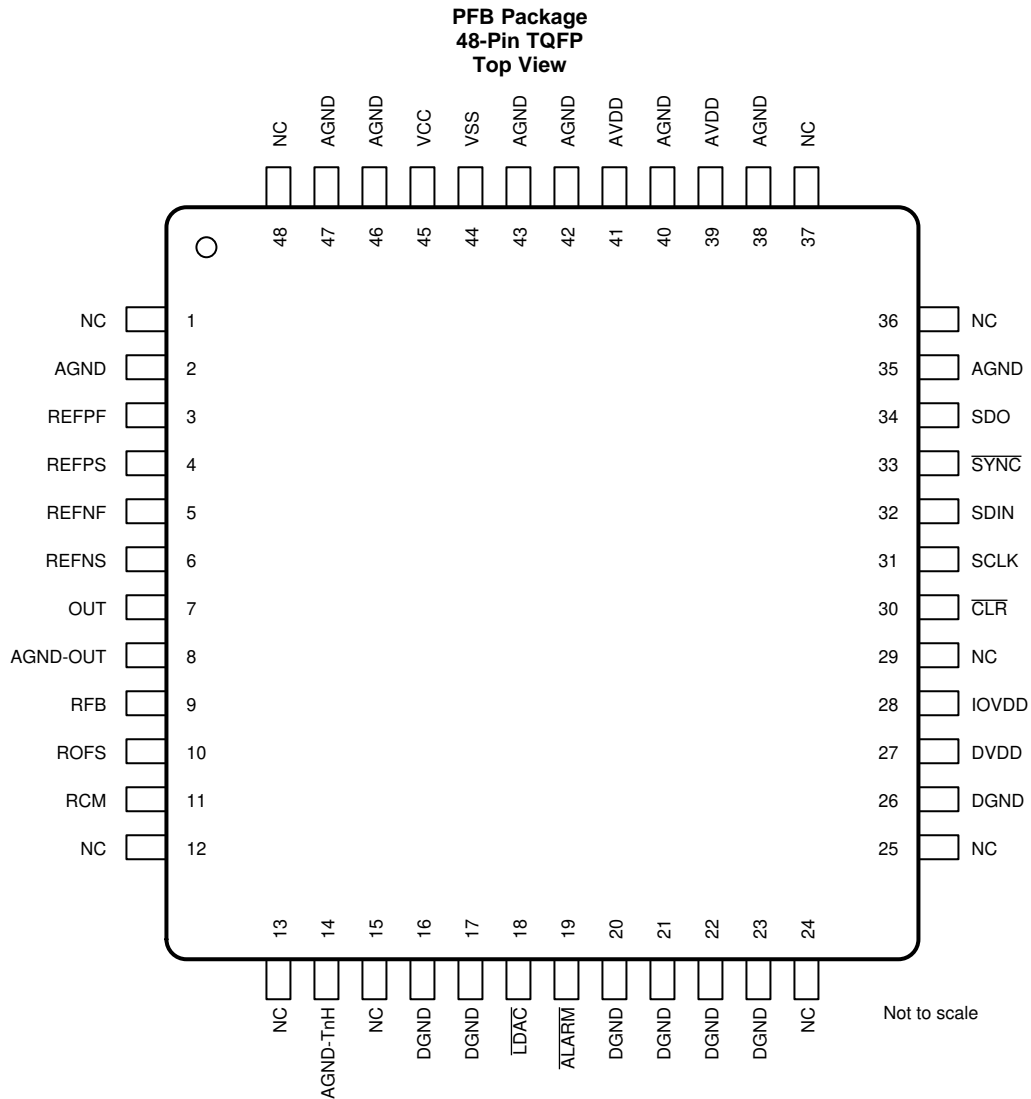

Pin Functions

PIN		TYPE	DESCRIPTION
NAME	NO.		
AGND	2, 35, 38, 40, 42, 43, 46, 47	Analog ground	Connect to 0 V.
AGND-OUT	8	Analog ground	Connect to 0 V. Measure DAC output voltage with respect to this node.
AGND-TnH	14	Analog ground	Connect to 0 V. Integrated deglitcher clock ground..
$\overline{\text{ALARM}}$	19	Output	Alarm output
AVDD	39, 41	Power	Positive low voltage analog power supply
$\overline{\text{CLR}}$	30	Input	DAC registers clear pin, active low
DGND	16, 17, 20, 21, 22, 23, 26	Digital ground	Connect to 0 V.
DVDD	27	Power	Digital power supply pin
RFB	9	Input	Integrated precision resistor feedback node
IOVDD	28	Power	Interface power supply pin
$\overline{\text{LDAC}}$	18	Input	Load DAC pin, active low
NC	1, 12, 13, 15, 24, 25, 29, 36, 37, 48	—	No connection, leave floating
OUT	7	Output	Unbuffered voltage output
RCM	11	Input	Integrated precision resistor common-mode node
REFNF	5	Input	External negative reference input. Connect to 0 V for unipolar DAC output.
REFNS	6	Input	External negative reference sense node
REFPF	3	Input	External positive reference input
REFPS	4	Input	External positive reference sense node
ROFS	10	Input	Integrated precision resistor offset node
SCLK	31	Input	Serial clock input of serial peripheral interface (SPI). Schmitt-trigger logic input. Data are transferred at rates of up to 50 MHz.
SDIN	32	Input	Serial data input. Schmitt-trigger logic input. Data are clocked into the input shift register on the falling edge of the serial clock input.
SDO	34	Output	Serial data output. Data are valid on the falling edge of SCLK.
$\overline{\text{SYNC}}$	33	Input	SPI bus chip select input (active low). Data bits are not clocked into the serial shift register unless $\overline{\text{SYNC}}$ is low. When $\overline{\text{SYNC}}$ is high, the SDO pin is in high-impedance status.
VCC	45	Power	Analog positive power supply
VSS	44	Power	Analog negative power supply

7 Specifications

7.1 Absolute Maximum Ratings

over operating free-air temperature range (unless otherwise noted)⁽¹⁾

			MIN	MAX	UNIT
Positive supply voltage	AV _{DD} to AGND		-0.3	7	V
	V _{CC} to V _{SS}		-0.3	40	
	V _{CC} to AGND		-0.3	40	
Negative supply voltage	V _{SS} to AGND		-19	0.3	V
Positive reference voltage	V _{REFPF} to V _{REFNF}		-0.3	40	V
	V _{REFPF} to V _{CC}		-0.3	V _{CC} + 0.3	
	V _{REFPF} to AGND		-0.3	40	
Negative reference voltage	V _{REFNF} to AGND		-19	0.3	V
	V _{REFNF} to V _{SS}		V _{SS} - 0.3	0.3	
Digital and IO power supply	DV _{DD} , IOV _{DD} to DGND		-0.3	7	V
Digital input(s) to DGND			DGND - 0.3	IOV _{DD} + 0.3	V
V _{OUT} , V _{RFB} , V _{RCM} , V _{ROFS}	to AGND (V _{SS} = AGND)		V _{SS}	V _{CC}	V
	to V _{SS}		0	V _{CC}	
Alarm pin voltage, $\overline{\text{ALARM}}$ to DGND			-0.3	DV _{DD} + 0.3	V
Digital output, SDO to DGND			-0.3	DV _{DD} + 0.3	V
Current into any pin			-10	10	mA
T _J	Junction temperature			150	°C
T _{stg}	Storage temperature		-65	150	°C

- (1) Stresses beyond those listed under Absolute Maximum Ratings may cause permanent damage to the device. These are stress ratings only, which do not imply functional operation of the device at these or any other conditions beyond those indicated under Recommended Operating Conditions. Exposure to absolute-maximum-rated conditions for extended periods may affect device reliability.

7.2 ESD Ratings

			VALUE	UNIT
V _(ESD)	Electrostatic discharge	Human body model (HBM), per ANSI/ESDA/JEDEC JS-001, all pins ⁽¹⁾	±1000	V
		Charged device model (CDM), per JEDEC specification JESD22-C101, all pins ⁽²⁾	±250	

- (1) JEDEC document JEP155 states that 500-V HBM allows safe manufacturing with a standard ESD control process.
(2) JEDEC document JEP157 states that 250-V CDM allows safe manufacturing with a standard ESD control process.

7.3 Recommended Operating Conditions

over operating free-air temperature range (unless otherwise noted)

		MIN	NOM	MAX	UNIT
	V_{DD} to AGND	4.5		5.5	V
	V_{SS} to AGND	-18		-3	V
	V_{CC} to AGND	8		33	V
	V_{CC} to V_{SS}	11		36	V
	DV_{DD} to DGND	2.7		5.5	V
	IOV_{DD} to DGND	1.7		5.5	V
	AGND to DGND	-0.3		0.3	V
	V_{IH} digital input high voltage	$0.7 \times IOV_{DD}$			V
	V_{IL} digital input low voltage			$0.3 \times IOV_{DD}$	V
	V_{REFPF} to AGND	3		15	V
	V_{REFNF} to AGND	-15		0	V
	V_{REFPF} to V_{REFNF}	3		30	V
T_A	Operating temperature	-40		125	°C

7.4 Thermal Information Package

THERMAL METRIC ⁽¹⁾		DAC11001A, DAC91001, DAC81001	UNIT
		PFB (TQFP)	
		48 PINS	
$R_{\theta JA}$	Junction-to-ambient thermal resistance	51.0	°C/W
$R_{\theta JC(top)}$	Junction-to-case (top) thermal resistance	10.3	°C/W
$R_{\theta JB}$	Junction-to-board thermal resistance	16.2	°C/W
Ψ_{JT}	Junction-to-top characterization parameter	0.3	°C/W
Ψ_{JB}	Junction-to-board characterization parameter	16.0	°C/W
$R_{\theta JC(bot)}$	Junction-to-case (bottom) thermal resistance	N/A	°C/W

- (1) For more information about traditional and new thermal metrics, see the [Semiconductor and IC Package Thermal Metrics application report](#).

7.5 Electrical Characteristics

at $T_A = -40^\circ\text{C}$ to $+125^\circ\text{C}$, $V_{CC} = +15\text{ V}$, $V_{SS} = -15\text{ V}$, $AV_{DD} = 5.5\text{ V}$, $DV_{DD} = 3.3\text{ V}$, $IOV_{DD} = 1.8\text{ V}$, see note⁽¹⁾ for V_{REFPF} and V_{REFNF} , 20-bit orderable used, OUT pin buffered with unity gain OPA827, ROFS, RCM, RFB unconnected, and all typical specifications at $T_A = 25^\circ\text{C}$, (unless otherwise noted)

PARAMETER		TEST CONDITIONS	MIN	TYP	MAX	UNIT
STATIC PERFORMANCE						
	Resolution	DAC11001A	20		Bits	
		DAC91001	18			
		DAC81001	16			
INL	Relative accuracy ⁽²⁾	DAC11001A	-4		4	LSB
		DAC11001A ⁽³⁾⁽⁴⁾	-2.6		2.6	
		DAC11001A, $T_A = 25^\circ\text{C}$ ⁽⁴⁾	-2		2	
		DAC91001	-1		1	
		DAC81001	-1		1	
	Relative accuracy drift over time ⁽²⁾	$T_A = 25^\circ\text{C}$, 1000 hrs		± 0.1		LSB
DNL	Differential nonlinearity ⁽²⁾⁽³⁾		-1		1	LSB
	Zero code error ⁽⁴⁾	DAC11001A, $T_A = 0^\circ\text{C}$ to 70°C , code 0d into DAC, unipolar ranges only	-4		4	LSB
		DAC11001A, $T_A = -40^\circ\text{C}$ to $+125^\circ\text{C}$, code 0d into DAC, unipolar ranges only	-4		4	
		DAC11001A, $T_A = 25^\circ\text{C}$, unipolar ranges only		± 2		
		DAC91001, $T_A = -40^\circ\text{C}$ to $+125^\circ\text{C}$, code 0d into DAC, unipolar ranges only	-4		4	
		DAC81001, $T_A = -40^\circ\text{C}$ to $+125^\circ\text{C}$, code 0d into DAC, unipolar ranges only	-4		4	
	Zero code error temperature coefficient	$T_A = 0^\circ\text{C}$ to 70°C , code 0d into DAC, unipolar ranges only		± 0.04		ppm FSR/ $^\circ\text{C}$
		$T_A = -40^\circ\text{C}$ to $+125^\circ\text{C}$, code 0d into DAC, unipolar ranges only		± 0.04		
	Gain error ⁽²⁾⁽⁴⁾	DAC11001A, $T_A = 0^\circ\text{C}$ to 70°C	-8		8	ppm of FSR
		DAC11001A, $T_A = 0^\circ\text{C}$ to 70°C , $V_{REFPF} = 3\text{ V}$, $V_{REFNF} = -10\text{ V}$	-8		8	
		DAC11001A, $T_A = -40^\circ\text{C}$ to $+125^\circ\text{C}$	-10		10	
		DAC11001A, $T_A = 25^\circ\text{C}$		± 2		
		DAC91001, $T_A = -40^\circ\text{C}$ to $+125^\circ\text{C}$	-10		10	
		DAC81001, $T_A = -40^\circ\text{C}$ to $+125^\circ\text{C}$	-10		10	
	Gain error temperature coefficient	$T_A = 0^\circ\text{C}$ to 70°C		± 0.04		ppm FSR/ $^\circ\text{C}$
		$T_A = 0^\circ\text{C}$ to 70°C , $V_{REFPF} = 3\text{ V}$, $V_{REFNF} = -10\text{ V}$		± 0.04		
		$T_A = -40^\circ\text{C}$ to $+125^\circ\text{C}$		± 0.04		

(1) Specified for the following pairs: $V_{REFPF} = 5\text{ V}$ and $V_{REFNF} = 0\text{ V}$; $V_{REFPF} = 10\text{ V}$ and $V_{REFNF} = 0\text{ V}$; $V_{REFPF} = +5\text{ V}$ and $V_{REFNF} = -5\text{ V}$; $V_{REFPF} = +10\text{ V}$ and $V_{REFNF} = -10\text{ V}$.

(2) Calculated between code 0d to 1048575d for DAC11001A, code 0d to 262143d for DAC91001, code 0d to 65535d for DAC81001.

(3) With device temperature calibration mode enabled and used.

(4) Specified by design, not production tested.

Electrical Characteristics (continued)

at $T_A = -40^\circ\text{C}$ to $+125^\circ\text{C}$, $V_{CC} = +15\text{ V}$, $V_{SS} = -15\text{ V}$, $AV_{DD} = 5.5\text{ V}$, $DV_{DD} = 3.3\text{ V}$, $IOV_{DD} = 1.8\text{ V}$, see note⁽¹⁾ for V_{REFPF} and V_{REFNF} , 20-bit orderable used, OUT pin buffered with unity gain OPA827, ROFS, RCM, RFB unconnected, and all typical specifications at $T_A = 25^\circ\text{C}$, (unless otherwise noted)

PARAMETER		TEST CONDITIONS	MIN	TYP	MAX	UNIT
	Positive full-scale error ⁽⁴⁾	DAC11001A, $T_A = 0^\circ\text{C}$ to 70°C , code 1048575d into DAC	-8		8	LSB
		DAC11001A, $T_A = 0^\circ\text{C}$ to 70°C , code 1048575d into DAC, $V_{REFPF} = 3\text{ V}$, $V_{REFNF} = -10\text{ V}$	-6		6	
		DAC11001A, $T_A = -40^\circ\text{C}$ to $+125^\circ\text{C}$, code 1048575d into DAC	-10		10	
		DAC11001A, $T_A = 25^\circ\text{C}$, code 1048575d into DAC		±2		
		DAC91001, $T_A = -40^\circ\text{C}$ to $+125^\circ\text{C}$, code 262143d into DAC	-10		10	
		DAC81001, $T_A = -40^\circ\text{C}$ to $+125^\circ\text{C}$, code 65535d into DAC	-10		10	
	Full-scale error temperature coefficient	$T_A = 0^\circ\text{C}$ to 70°C		±0.04		ppm FSR/°C
		$T_A = 0^\circ\text{C}$ to 70°C , $V_{REFPF} = 3\text{ V}$, $V_{REFNF} = -10\text{ V}$		±0.04		
		$T_A = -40^\circ\text{C}$ to $+125^\circ\text{C}$		±0.04		
OUTPUT CHARACTERISTICS						
	Headroom	From V_{REFPF} to V_{CC}	3			V
	Footroom	From V_{REFNF} to V_{SS}	3			V
	DC impedance	From ROFS to RCM		5		kΩ
		From RCM to RFB		5		
Z_O	DC output impedance			2.5		kΩ
	Power supply rejection ratio (dc)	$T_A = 25^\circ\text{C}$, $V_{CC} = 15\text{ V} \pm 20\%$, $V_{SS} = -15\text{ V}$		1.5		μV/V
		$T_A = 25^\circ\text{C}$, $V_{CC} = 15\text{ V}$, $V_{SS} = -15\text{ V} \pm 20\%$		1		
	Output voltage drift over time	$T_A = 25^\circ\text{C}$, $V_{OUT} = \text{midscale}$, 1000 hr		1		ppm of FSR
VOLTAGE REFERENCE INPUT						
	Reference input impedance (REFPF)	DAC at midscale, $V_{REFPF} = 10\text{ V}$, $V_{REFNF} = 0\text{ V}$		5.5		kΩ
	Reference input impedance (REFNF)	DAC at midscale, $V_{REFPF} = 10\text{ V}$, $V_{REFNF} = 0\text{ V}$		7		

Electrical Characteristics (continued)

at $T_A = -40^{\circ}\text{C}$ to $+125^{\circ}\text{C}$, $V_{CC} = +15\text{ V}$, $V_{SS} = -15\text{ V}$, $AV_{DD} = 5.5\text{ V}$, $DV_{DD} = 3.3\text{ V}$, $IOV_{DD} = 1.8\text{ V}$, see note⁽¹⁾ for V_{REFPF} and V_{REFNF} , 20-bit orderable used, OUT pin buffered with unity gain OPA827, ROFS, RCM, RFB unconnected, and all typical specifications at $T_A = 25^{\circ}\text{C}$, (unless otherwise noted)

PARAMETER	TEST CONDITIONS	MIN	TYP	MAX	UNIT
DYNAMIC PERFORMANCE					
t_s	Output voltage settling time ⁽⁵⁾	$V_{REFPF} = 10\text{ V}$, $V_{REFNF} = 0\text{ V}$, full-scale settling to 0.1%FSR		1	μs
		$V_{REFPF} = 10\text{ V}$, $V_{REFNF} = 0\text{ V}$, full-scale settling to $\pm 1\text{ LSB}$		2.5	
		$V_{REFPF} = 10\text{ V}$, $V_{REFNF} = 0\text{ V}$, 1-mV step settling to $\pm 1\text{ LSB}$		2.5	
SR	Slew rate	$V_{REFPF} = 10\text{ V}$, $V_{REFNF} = 0\text{ V}$, full-scale step, measured at OUT pin		50	$\text{V}/\mu\text{s}$
	Power-on glitch magnitude	Measured at unbuffered DAC voltage output, $V_{REFPF} = 10\text{ V}$, $V_{REFNF} = 0\text{ V}$		-0.2	V
V_n	Output noise	0.1-Hz to 10-Hz, DAC at midscale, $V_{REFPF} = 10\text{ V}$, $V_{REFNF} = 0\text{ V}$		0.4	μVpp
		100-kHz bandwidth, DAC at midscale, $V_{REFPF} = 10\text{ V}$, $V_{REFNF} = 0\text{ V}$		3	μVrms
	Output noise density	Measured at 1 kHz, 10 kHz, 100 kHz, DAC at mid scale, $V_{REFPF} = 10\text{ V}$, $V_{REFNF} = 0\text{ V}$		7	$\text{nV}/\sqrt{\text{Hz}}$
SFDR	Spurious free dynamic range	DAC update rate = 400 kHz, $f_{OUT} = 1\text{ kHz}$, $V_{OUTPP} = 0\text{ V}$ to 10 V		-105	dB
		DAC update rate = 400 kHz, $f_{OUT} = 1\text{ kHz}$, $V_{OUTPP} = 3\text{ V}$ to -10 V		-105	dB
THD	Total harmonic distortion	DAC update rate = 400 kHz, $f_{OUT} = 1\text{ kHz}$, $V_{OUTPP} = 0\text{ V}$ to 10 V		-105	dB
		DAC update rate = 400 kHz, $f_{OUT} = 1\text{ kHz}$, $V_{OUTPP} = 3\text{ V}$ to -10 V		-105	dB
	Power supply rejection ratio (ac)	200-mV 50-Hz or 60-Hz sine wave superimposed on V_{SS} , $V_{CC} = 15\text{ V}$		95	dB
		200-mV 50 Hz or 60 Hz sine wave superimposed on V_{CC} , $V_{SS} = -15\text{ V}$		95	dB
	Code change glitch impulse	$\pm 1\text{ LSB}$ change around mid code (including feedthrough), $V_{REFPF} = 10\text{ V}$, $V_{REFNF} = 0\text{ V}$, measured at output of buffer op amp		1	nV-s
	Code change glitch impulse magnitude	$\pm 1\text{ LSB}$ change around mid code (including feedthrough), $V_{REFPF} = 10\text{ V}$, $V_{REFNF} = 0\text{ V}$, measured at output of buffer op amp		5	mV
	Reference feedthrough	$V_{REFPF} = 10\text{ V} \pm 10\%$, $V_{REFNF} = 0\text{ V}$, frequency = 100 Hz, DAC at zero scale		-90	dB
	Reference feedthrough	$V_{REFNF} = -10\text{ V} \pm 10\%$, $V_{REFPF} = 10\text{ V}$, frequency = 100 Hz, DAC at full scale		-90	dB
	Digital feedthrough	At SCLK = 1 MHz, DAC output static at midscale, 10-V range		1	nV-s

(5) Adaptive TnH mode. TnH action is disabled for large code steps. For small steps, TnH action happens with a hold time of 1.2 μs .

Electrical Characteristics (continued)

at $T_A = -40^\circ\text{C}$ to $+125^\circ\text{C}$, $V_{CC} = +15\text{ V}$, $V_{SS} = -15\text{ V}$, $AV_{DD} = 5.5\text{ V}$, $DV_{DD} = 3.3\text{ V}$, $IOV_{DD} = 1.8\text{ V}$, see note⁽¹⁾ for V_{REFPF} and V_{REFNF} , 20-bit orderable used, OUT pin buffered with unity gain OPA827, ROFS, RCM, RFB unconnected, and all typical specifications at $T_A = 25^\circ\text{C}$, (unless otherwise noted)

PARAMETER		TEST CONDITIONS	MIN	TYP	MAX	UNIT
DIGITAL INPUTS						
	Hysteresis voltage			0.4		V
	Input current			± 5		μA
	Pin capacitance	Per pin		10		pF
DIGITAL OUTPUTS						
V_{OL}	Output low voltage	sinking 200 μA			0.4	V
V_{OH}	Output high voltage	sourcing 200 μA	$IOV_{DD} - 0.5$			V
	High impedance leakage			± 5		μA
	High impedance output capacitance			10		pF
POWER						
I_{AVDD}	Current flowing into AV_{DD}	$V_{REFPF} = 10\text{ V}$, $V_{REFNF} = 0\text{ V}$, midscale code			1.5	mA
I_{VCC}	Current flowing into V_{CC}	$V_{REFPF} = 10\text{ V}$, $V_{REFNF} = 0\text{ V}$, midscale code			7	mA
I_{VSS}	Current flowing into V_{SS}	$V_{REFPF} = 10\text{ V}$, $V_{REFNF} = 0\text{ V}$, midscale code			7	mA
I_{DVDD}	Current flowing into DV_{DD}	$V_{REFPF} = 10\text{ V}$, $V_{REFNF} = 0\text{ V}$, midscale code		0.5		mA
I_{IOVDD}	Current flowing into IOV_{DD}	$V_{REFPF} = 10\text{ V}$, $V_{REFNF} = 0\text{ V}$, midscale code, all digital input pins static at IOV_{DD}		0.1		mA
I_{REFPF}	Reference input current (V_{REFPF})	$V_{REFPF} = 10\text{ V}$, $V_{REFNF} = 0\text{ V}$, midscale code			5	mA
I_{REFNF}	Reference input current (V_{REFNF})	$V_{REFPF} = 10\text{ V}$, $V_{REFNF} = 0\text{ V}$, midscale code			5	mA

7.6 Timing Requirements: Write, $4.5\text{ V} \leq DV_{DD} \leq 5.5\text{ V}$

all input signals are specified with $t_R = t_F = 1\text{ ns/V}$ (10% to 90% of IOV_{DD}) and timed from a voltage level of $(V_{IL} + V_{IH}) / 2$, SDO loaded with 20 pF, and $T_A = -40^\circ\text{C}$ to $+125^\circ\text{C}$ (unless otherwise noted)

		MIN	NOM	MAX	UNIT
f_{SCLK}	SCLK frequency, $1.7\text{ V} \leq IOV_{DD} < 2.7\text{ V}$			33	MHz
	SCLK frequency, $2.7\text{ V} \leq IOV_{DD} \leq 5.5\text{ V}$			50	
$t_{SCLKHIGH}$	SCLK high time, $1.7\text{ V} \leq IOV_{DD} < 2.7\text{ V}$	15			ns
	SCLK high time, $2.7\text{ V} \leq IOV_{DD} \leq 5.5\text{ V}$	10			
$t_{SCLKLOW}$	SCLK low time, $1.7\text{ V} \leq IOV_{DD} < 2.7\text{ V}$	15			ns
	SCLK low time, $2.7\text{ V} \leq IOV_{DD} \leq 5.5\text{ V}$	10			
t_{SDIS}	SDI setup, $1.7\text{ V} \leq IOV_{DD} < 2.7\text{ V}$	13			ns
	SDI setup, $2.7\text{ V} \leq IOV_{DD} \leq 5.5\text{ V}$	8			
t_{SDIH}	SDI hold, $1.7\text{ V} \leq IOV_{DD} < 2.7\text{ V}$	13			ns
	SDI hold, $2.7\text{ V} \leq IOV_{DD} \leq 5.5\text{ V}$	8			
t_{CSS}	\overline{SYNC} falling edge to SCLK falling edge, $1.7\text{ V} \leq IOV_{DD} < 2.7\text{ V}$	23			ns
	\overline{SYNC} falling edge to SCLK falling edge, $2.7\text{ V} \leq IOV_{DD} \leq 5.5\text{ V}$	18			
t_{CSH}	SCLK falling edge to \overline{SYNC} rising edge, $1.7\text{ V} \leq IOV_{DD} < 2.7\text{ V}$	15			ns
	SCLK falling edge to \overline{SYNC} rising edge, $2.7\text{ V} \leq IOV_{DD} \leq 5.5\text{ V}$	10			
t_{CSHIGH}	\overline{SYNC} high time, $1.7\text{ V} \leq IOV_{DD} < 2.7\text{ V}$	55			ns
	\overline{SYNC} high time, $2.7\text{ V} \leq IOV_{DD} \leq 5.5\text{ V}$	50			
$t_{CSIGNORE}$	SCLK falling edge to \overline{SYNC} ignore, $1.7\text{ V} \leq IOV_{DD} < 2.7\text{ V}$	10			ns
	SCLK falling edge to \overline{SYNC} ignore, $2.7\text{ V} \leq IOV_{DD} \leq 5.5\text{ V}$	5			
t_{LDACSL}	Synchronous update: \overline{SYNC} rising edge to \overline{LDAC} falling edge, $1.7\text{ V} \leq IOV_{DD} < 2.7\text{ V}$	50			ns
	Synchronous update: \overline{SYNC} rising edge to \overline{LDAC} falling edge, $2.7\text{ V} \leq IOV_{DD} \leq 5.5\text{ V}$	50			
t_{LDACW}	\overline{LDAC} low time, $1.7\text{ V} \leq IOV_{DD} < 2.7\text{ V}$	20			ns
	\overline{LDAC} low time, $2.7\text{ V} \leq IOV_{DD} \leq 5.5\text{ V}$	20			
$t_{CLR W}$	\overline{CLR} low time, $1.7\text{ V} \leq IOV_{DD} < 2.7\text{ V}$	20			ns
	\overline{CLR} low time, $2.7\text{ V} \leq IOV_{DD} \leq 5.5\text{ V}$	20			

7.7 Timing Requirements: Write, $2.7\text{ V} \leq DV_{DD} < 4.5\text{ V}$

all input signals are specified with $t_R = t_F = 1\text{ ns/V}$ (10% to 90% of IOV_{DD}) and timed from a voltage level of $(V_{IL} + V_{IH}) / 2$, SDO loaded with 20 pF, and $T_A = -40^\circ\text{C}$ to $+125^\circ\text{C}$ (unless otherwise noted)

		MIN	NOM	MAX	UNIT
f_{SCLK}	SCLK frequency, $1.7\text{ V} \leq IOV_{DD} < 2.7\text{ V}$			20	MHz
	SCLK frequency, $2.7\text{ V} \leq IOV_{DD} \leq 5.5\text{ V}$			25	
t_{SCLKHIGH}	SCLK high time, $1.7\text{ V} \leq IOV_{DD} < 2.7\text{ V}$	25			ns
	SCLK high time, $2.7\text{ V} \leq IOV_{DD} \leq 5.5\text{ V}$	20			
t_{SCLKLOW}	SCLK low time, $1.7\text{ V} \leq IOV_{DD} < 2.7\text{ V}$	25			ns
	SCLK low time, $2.7\text{ V} \leq IOV_{DD} \leq 5.5\text{ V}$	20			
t_{SDIS}	SDI setup, $1.7\text{ V} \leq IOV_{DD} < 2.7\text{ V}$	21			ns
	SDI setup, $2.7\text{ V} \leq IOV_{DD} \leq 5.5\text{ V}$	16			
t_{SDIH}	SDI hold, $1.7\text{ V} \leq IOV_{DD} < 2.7\text{ V}$	21			ns
	SDI hold, $2.7\text{ V} \leq IOV_{DD} \leq 5.5\text{ V}$	16			
t_{CSS}	$\overline{\text{SYNC}}$ falling edge to SCLK falling edge, $1.7\text{ V} \leq IOV_{DD} < 2.7\text{ V}$	41			ns
	$\overline{\text{SYNC}}$ falling edge to SCLK falling edge, $2.7\text{ V} \leq IOV_{DD} \leq 5.5\text{ V}$	36			
t_{CSH}	SCLK falling edge to $\overline{\text{SYNC}}$ rising edge, $1.7\text{ V} \leq IOV_{DD} < 2.7\text{ V}$	25			ns
	SCLK falling edge to $\overline{\text{SYNC}}$ rising edge, $2.7\text{ V} \leq IOV_{DD} \leq 5.5\text{ V}$	20			
t_{CSHIGH}	$\overline{\text{SYNC}}$ high time, $1.7\text{ V} \leq IOV_{DD} < 2.7\text{ V}$	100			ns
	$\overline{\text{SYNC}}$ high time, $2.7\text{ V} \leq IOV_{DD} \leq 5.5\text{ V}$	100			
t_{CSIGNORE}	SCLK falling edge to $\overline{\text{SYNC}}$ ignore, $1.7\text{ V} \leq IOV_{DD} < 2.7\text{ V}$	10			ns
	SCLK falling edge to $\overline{\text{SYNC}}$ ignore, $2.7\text{ V} \leq IOV_{DD} \leq 5.5\text{ V}$	5			
t_{LDACSL}	Synchronous update: $\overline{\text{SYNC}}$ rising edge to $\overline{\text{LDAC}}$ falling edge, $1.7\text{ V} \leq IOV_{DD} < 2.7\text{ V}$	100			ns
	Synchronous update: $\overline{\text{SYNC}}$ rising edge to $\overline{\text{LDAC}}$ falling edge, $2.7\text{ V} \leq IOV_{DD} \leq 5.5\text{ V}$	100			
t_{LDACW}	$\overline{\text{LDAC}}$ low time, $1.7\text{ V} \leq IOV_{DD} < 2.7\text{ V}$	40			ns
	$\overline{\text{LDAC}}$ low time, $2.7\text{ V} \leq IOV_{DD} \leq 5.5\text{ V}$	40			
t_{CLRW}	$\overline{\text{CLR}}$ low time, $1.7\text{ V} \leq IOV_{DD} < 2.7\text{ V}$	40			ns
	$\overline{\text{CLR}}$ low time, $2.7\text{ V} \leq IOV_{DD} \leq 5.5\text{ V}$	40			

7.8 Timing Requirements: Read and Daisy-Chain Write, $4.5\text{ V} \leq \text{DV}_{\text{DD}} \leq 5.5\text{ V}$

all input signals are specified with $t_{\text{R}} = t_{\text{F}} = 1\text{ ns/V}$ (10% to 90% of IOV_{DD}) and timed from a voltage level of $(V_{\text{IL}} + V_{\text{IH}}) / 2$, SDO loaded with 20 pF, and $T_{\text{A}} = -40^{\circ}\text{C}$ to $+125^{\circ}\text{C}$ (unless otherwise noted)

		MIN	NOM	MAX	UNIT
f_{SCLK}	SCLK frequency	$1.7\text{ V} \leq \text{IOV}_{\text{DD}} < 2.7\text{ V}$, FSDO = 0		10	MHz
		$1.7\text{ V} \leq \text{IOV}_{\text{DD}} < 2.7\text{ V}$, FSDO = 1		20	
		$2.7\text{ V} \leq \text{IOV}_{\text{DD}} \leq 5.5\text{ V}$, FSDO = 0		15	
		$2.7\text{ V} \leq \text{IOV}_{\text{DD}} \leq 5.5\text{ V}$, FSDO = 1		30	
t_{SCLKHIGH}	SCLK high time	$1.7\text{ V} \leq \text{IOV}_{\text{DD}} < 2.7\text{ V}$, FSDO = 0		50	ns
		$1.7\text{ V} \leq \text{IOV}_{\text{DD}} < 2.7\text{ V}$, FSDO = 1		25	
		$2.7\text{ V} \leq \text{IOV}_{\text{DD}} \leq 5.5\text{ V}$, FSDO = 0		33	
		$2.7\text{ V} \leq \text{IOV}_{\text{DD}} \leq 5.5\text{ V}$, FSDO = 1		16	
t_{SCLKLOW}	SCLK low time	$1.7\text{ V} \leq \text{IOV}_{\text{DD}} < 2.7\text{ V}$, FSDO = 0		50	ns
		$1.7\text{ V} \leq \text{IOV}_{\text{DD}} < 2.7\text{ V}$, FSDO = 1		25	
		$2.7\text{ V} \leq \text{IOV}_{\text{DD}} \leq 5.5\text{ V}$, FSDO = 0		33	
		$2.7\text{ V} \leq \text{IOV}_{\text{DD}} \leq 5.5\text{ V}$, FSDO = 1		16	
t_{SDIS}	SDI setup, $1.7\text{ V} \leq \text{IOV}_{\text{DD}} < 2.7\text{ V}$			13	ns
	SDI setup, $2.7\text{ V} \leq \text{IOV}_{\text{DD}} \leq 5.5\text{ V}$			8	
t_{SDIH}	SDI hold, $1.7\text{ V} \leq \text{IOV}_{\text{DD}} < 2.7\text{ V}$			13	ns
	SDI hold, $2.7\text{ V} \leq \text{IOV}_{\text{DD}} \leq 5.5\text{ V}$			8	
t_{CSS}	$\overline{\text{SYNC}}$ falling edge to SCLK falling edge, $1.7\text{ V} \leq \text{IOV}_{\text{DD}} < 2.7\text{ V}$			30	ns
	$\overline{\text{SYNC}}$ falling edge to SCLK falling edge, $2.7\text{ V} \leq \text{IOV}_{\text{DD}} \leq 5.5\text{ V}$			20	
t_{CSH}	SCLK falling edge to $\overline{\text{SYNC}}$ rising edge, $1.7\text{ V} \leq \text{IOV}_{\text{DD}} < 2.7\text{ V}$			15	ns
	SCLK falling edge to $\overline{\text{SYNC}}$ rising edge, $2.7\text{ V} \leq \text{IOV}_{\text{DD}} \leq 5.5\text{ V}$			10	
t_{CSHIGH}	$\overline{\text{SYNC}}$ high time, $1.7\text{ V} \leq \text{IOV}_{\text{DD}} < 2.7\text{ V}$			55	ns
	$\overline{\text{SYNC}}$ high time, $2.7\text{ V} \leq \text{IOV}_{\text{DD}} \leq 5.5\text{ V}$			50	
t_{CSIGNORE}	SCLK falling edge to $\overline{\text{SYNC}}$ ignore, $1.7\text{ V} \leq \text{IOV}_{\text{DD}} < 2.7\text{ V}$			10	ns
	SCLK falling edge to $\overline{\text{SYNC}}$ ignore, $2.7\text{ V} \leq \text{IOV}_{\text{DD}} \leq 5.5\text{ V}$			5	
t_{LDACSL}	Synchronous update: $\overline{\text{SYNC}}$ rising edge to $\overline{\text{LDAC}}$ falling edge, $1.7\text{ V} \leq \text{IOV}_{\text{DD}} < 2.7\text{ V}$			50	ns
	Synchronous update: $\overline{\text{SYNC}}$ rising edge to $\overline{\text{LDAC}}$ falling edge, $2.7\text{ V} \leq \text{IOV}_{\text{DD}} \leq 5.5\text{ V}$			50	
t_{LDACW}	$\overline{\text{LDAC}}$ low time, $1.7\text{ V} \leq \text{IOV}_{\text{DD}} < 2.7\text{ V}$			20	ns
	$\overline{\text{LDAC}}$ low time, $2.7\text{ V} \leq \text{IOV}_{\text{DD}} \leq 5.5\text{ V}$			20	
t_{CLRW}	$\overline{\text{CLR}}$ low time, $1.7\text{ V} \leq \text{IOV}_{\text{DD}} < 2.7\text{ V}$			20	ns
	$\overline{\text{CLR}}$ low time, $2.7\text{ V} \leq \text{IOV}_{\text{DD}} \leq 5.5\text{ V}$			20	
t_{SDODLY}	SCLK rising edge to SDO valid data, $1.7\text{ V} \leq \text{IOV}_{\text{DD}} < 2.7\text{ V}$, FSDO = 0	0		35	ns
	SCLK rising edge to SDO valid data, $2.7\text{ V} \leq \text{IOV}_{\text{DD}} \leq 5.5\text{ V}$, FSDO = 0	0		25	
	SCLK falling edge to SDO valid data, $1.7\text{ V} \leq \text{IOV}_{\text{DD}} < 2.7\text{ V}$, FSDO = 1	0		35	
	SCLK falling edge to SDO valid data, $2.7\text{ V} \leq \text{IOV}_{\text{DD}} \leq 5.5\text{ V}$, FSDO = 1	0		25	
t_{SDOZ}	$\overline{\text{SYNC}}$ rising edge to SDO HiZ, $1.7\text{ V} \leq \text{IOV}_{\text{DD}} < 2.7\text{ V}$	0		20	ns
	$\overline{\text{SYNC}}$ rising edge to SDO HiZ, $2.7\text{ V} \leq \text{IOV}_{\text{DD}} \leq 5.5\text{ V}$	0		20	

7.9 Timing Requirements: Read and Daisy-Chain Write, $2.7\text{ V} \leq \text{DV}_{\text{DD}} < 4.5\text{ V}$

all input signals are specified with $t_{\text{R}} = t_{\text{F}} = 1\text{ ns/V}$ (10% to 90% of IOV_{DD}) and timed from a voltage level of $(V_{\text{IL}} + V_{\text{IH}}) / 2$, SDO loaded with 20 pF, and $T_{\text{A}} = -40^{\circ}\text{C}$ to $+125^{\circ}\text{C}$ (unless otherwise noted)

		MIN	NOM	MAX	UNIT
f_{SCLK}	SCLK frequency	$1.7\text{ V} \leq \text{IOV}_{\text{DD}} < 2.7\text{ V}$, FSDO = 0		8	MHz
		$1.7\text{ V} \leq \text{IOV}_{\text{DD}} < 2.7\text{ V}$, FSDO = 1		16	
		$2.7\text{ V} \leq \text{IOV}_{\text{DD}} \leq 5.5\text{ V}$, FSDO = 0		10	
		$2.7\text{ V} \leq \text{IOV}_{\text{DD}} \leq 5.5\text{ V}$, FSDO = 1		20	
t_{SCLKHIGH}	SCLK high time	$1.7\text{ V} \leq \text{IOV}_{\text{DD}} < 2.7\text{ V}$, FSDO = 0		62	ns
		$1.7\text{ V} \leq \text{IOV}_{\text{DD}} < 2.7\text{ V}$, FSDO = 1		31	
		$2.7\text{ V} \leq \text{IOV}_{\text{DD}} \leq 5.5\text{ V}$, FSDO = 0		50	
		$2.7\text{ V} \leq \text{IOV}_{\text{DD}} \leq 5.5\text{ V}$, FSDO = 1		25	
t_{SCLKLOW}	SCLK low time	$1.7\text{ V} \leq \text{IOV}_{\text{DD}} < 2.7\text{ V}$, FSDO = 0		62	ns
		$1.7\text{ V} \leq \text{IOV}_{\text{DD}} < 2.7\text{ V}$, FSDO = 1		31	
		$2.7\text{ V} \leq \text{IOV}_{\text{DD}} \leq 5.5\text{ V}$, FSDO = 0		50	
		$2.7\text{ V} \leq \text{IOV}_{\text{DD}} \leq 5.5\text{ V}$, FSDO = 1		25	
t_{SDIS}	SDI setup, $1.7\text{ V} \leq \text{IOV}_{\text{DD}} < 2.7\text{ V}$			21	ns
	SDI setup, $2.7\text{ V} \leq \text{IOV}_{\text{DD}} \leq 5.5\text{ V}$			16	
t_{SDIH}	SDI hold, $1.7\text{ V} \leq \text{IOV}_{\text{DD}} < 2.7\text{ V}$			21	ns
	SDI hold, $2.7\text{ V} \leq \text{IOV}_{\text{DD}} \leq 5.5\text{ V}$			16	
t_{CSS}	$\overline{\text{SYNC}}$ falling edge to SCLK falling edge, $1.7\text{ V} \leq \text{IOV}_{\text{DD}} < 2.7\text{ V}$			41	ns
	$\overline{\text{SYNC}}$ falling edge to SCLK falling edge, $2.7\text{ V} \leq \text{IOV}_{\text{DD}} \leq 5.5\text{ V}$			36	
t_{CSH}	SCLK falling edge to $\overline{\text{SYNC}}$ rising edge, $1.7\text{ V} \leq \text{IOV}_{\text{DD}} < 2.7\text{ V}$			25	ns
	SCLK falling edge to $\overline{\text{SYNC}}$ rising edge, $2.7\text{ V} \leq \text{IOV}_{\text{DD}} \leq 5.5\text{ V}$			20	
t_{CSHIGH}	$\overline{\text{SYNC}}$ high time, $1.7\text{ V} \leq \text{IOV}_{\text{DD}} < 2.7\text{ V}$			100	ns
	$\overline{\text{SYNC}}$ high time, $2.7\text{ V} \leq \text{IOV}_{\text{DD}} \leq 5.5\text{ V}$			100	
t_{CSIGNORE}	SCLK falling edge to $\overline{\text{SYNC}}$ ignore, $1.7\text{ V} \leq \text{IOV}_{\text{DD}} < 2.7\text{ V}$			10	ns
	SCLK falling edge to $\overline{\text{SYNC}}$ ignore, $2.7\text{ V} \leq \text{IOV}_{\text{DD}} \leq 5.5\text{ V}$			5	
t_{LDACSL}	Synchronous update: $\overline{\text{SYNC}}$ rising edge to $\overline{\text{LDAC}}$ falling edge, $1.7\text{ V} \leq \text{IOV}_{\text{DD}} < 2.7\text{ V}$			100	ns
	Synchronous update: $\overline{\text{SYNC}}$ rising edge to $\overline{\text{LDAC}}$ falling edge, $2.7\text{ V} \leq \text{IOV}_{\text{DD}} \leq 5.5\text{ V}$			100	
t_{LDACW}	$\overline{\text{LDAC}}$ low time, $1.7\text{ V} \leq \text{IOV}_{\text{DD}} < 2.7\text{ V}$			40	ns
	$\overline{\text{LDAC}}$ low time, $2.7\text{ V} \leq \text{IOV}_{\text{DD}} \leq 5.5\text{ V}$			40	
$t_{\text{CLR W}}$	$\overline{\text{CLR}}$ low time, $1.7\text{ V} \leq \text{IOV}_{\text{DD}} < 2.7\text{ V}$			40	ns
	$\overline{\text{CLR}}$ low time, $2.7\text{ V} \leq \text{IOV}_{\text{DD}} \leq 5.5\text{ V}$			40	
t_{SDODLY}	SCLK rising edge to SDO valid data, $1.7\text{ V} \leq \text{IOV}_{\text{DD}} < 2.7\text{ V}$, FSDO = 0	0		40	ns
	SCLK rising edge to SDO valid data, $2.7\text{ V} \leq \text{IOV}_{\text{DD}} \leq 5.5\text{ V}$, FSDO = 0	0		30	
	SCLK rising edge to SDO valid data, $1.7\text{ V} \leq \text{IOV}_{\text{DD}} < 2.7\text{ V}$, FSDO = 1	0		40	
	SCLK rising edge to SDO valid data, $2.7\text{ V} \leq \text{IOV}_{\text{DD}} \leq 5.5\text{ V}$, FSDO = 1	0		30	
t_{SDOZ}	$\overline{\text{SYNC}}$ rising edge to SDO HiZ, $1.7\text{ V} \leq \text{IOV}_{\text{DD}} < 2.7\text{ V}$	0		20	ns
	$\overline{\text{SYNC}}$ rising edge to SDO HiZ, $2.7\text{ V} \leq \text{IOV}_{\text{DD}} \leq 5.5\text{ V}$	0		20	

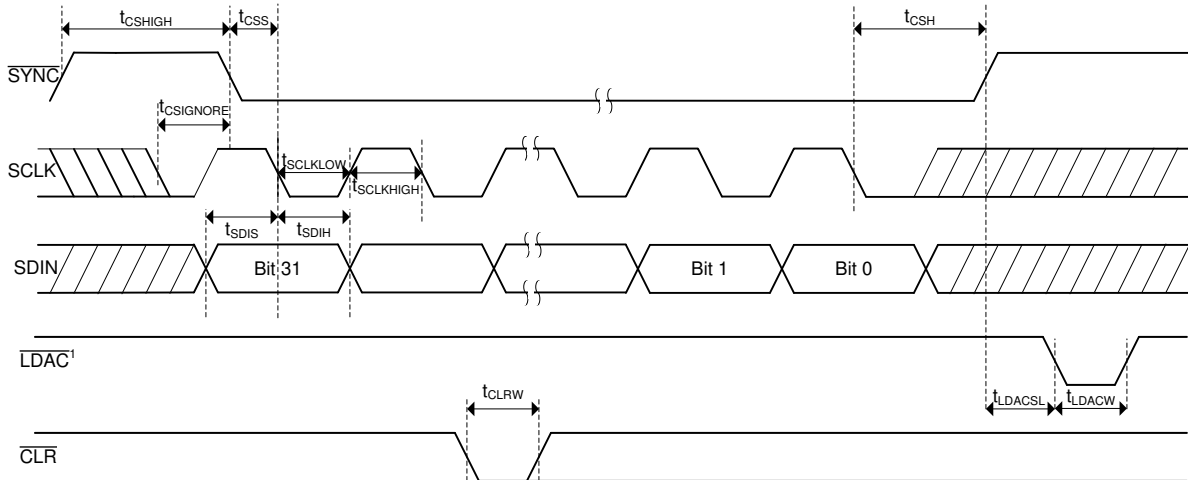

Figure 1. Serial Interface Write Timing: Standalone Mode

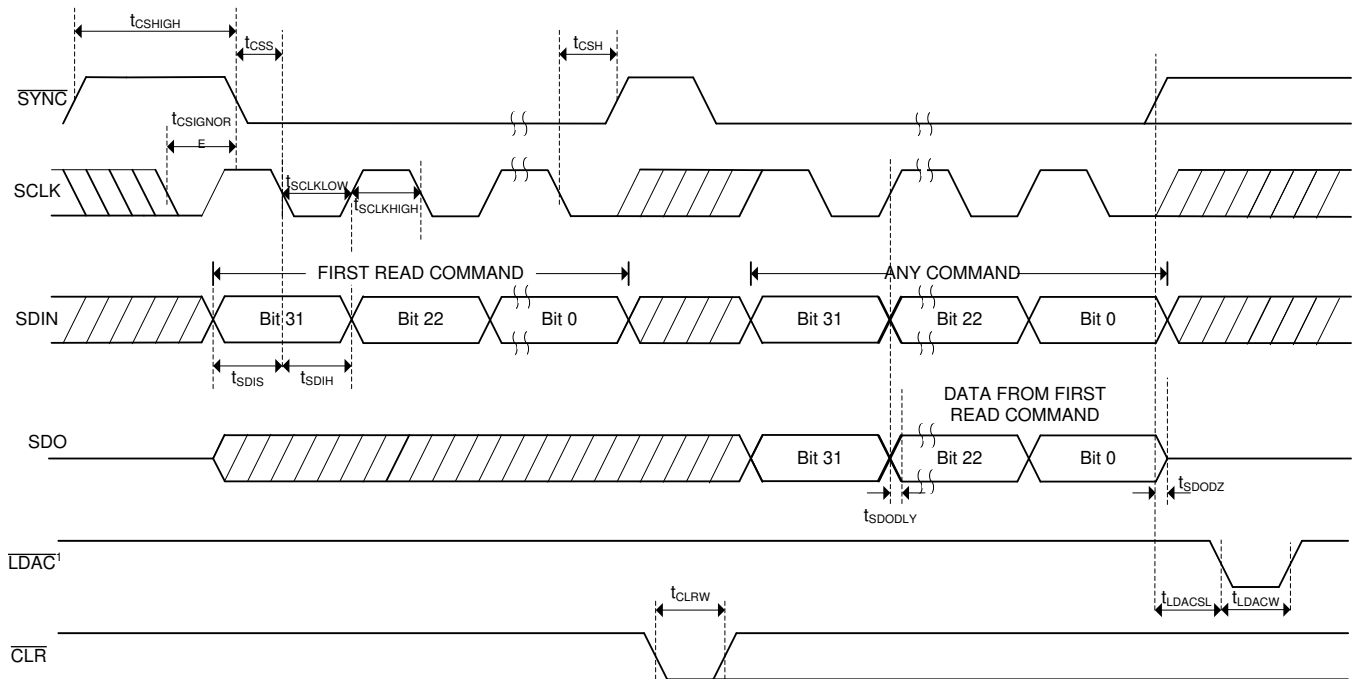

Figure 2. Serial Interface Read and Write Timing: Daisy-Chain Mode

7.10 Typical Characteristics

at $T_A = 25^\circ\text{C}$, $V_{CC} = 15\text{ V}$, $V_{SS} = -15\text{ V}$, $AV_{DD} = 5\text{ V}$, $IOV_{DD} = 1.8\text{ V}$, gain resistors unconnected (gain = 1x), OPA827 used as output and reference amplifier, UP = unipolar, BP = bipolar, and [temperature calibration](#) disabled (unless otherwise noted)

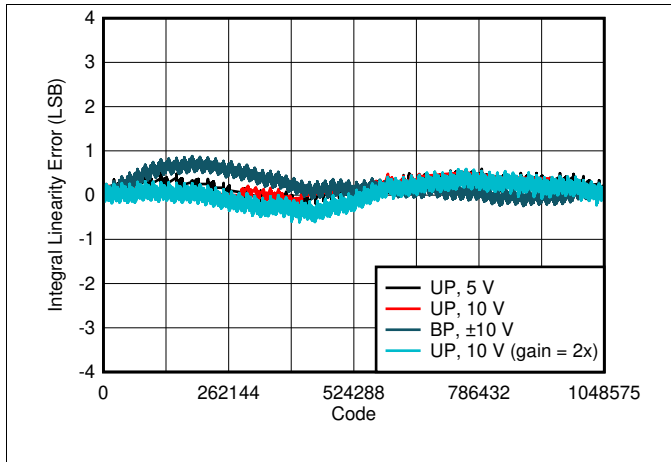

Figure 3. Integral Linearity Error vs Digital Input Code

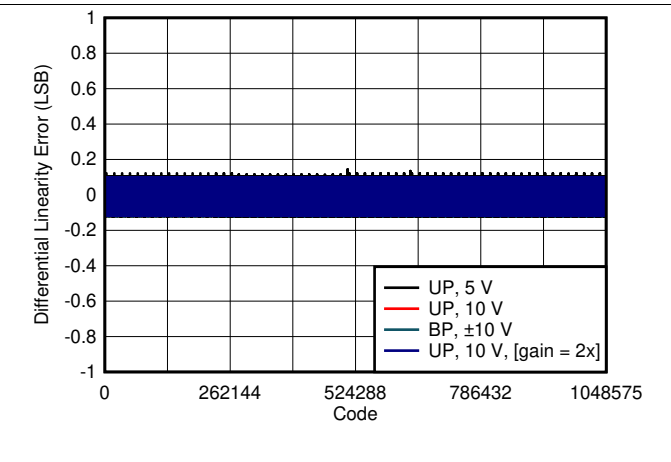

Figure 4. Differential Linearity Error vs Digital Input Code

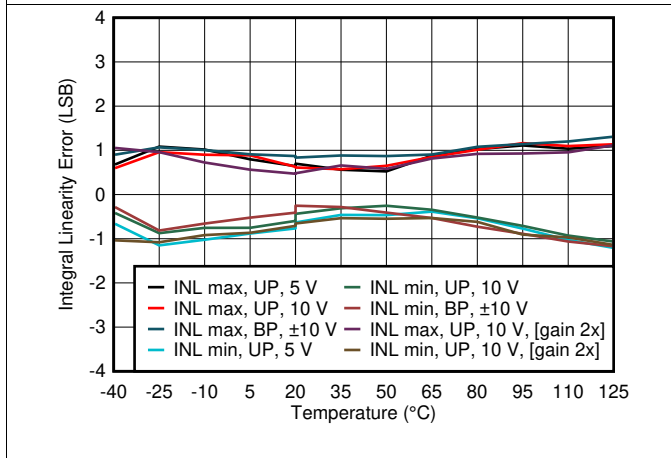
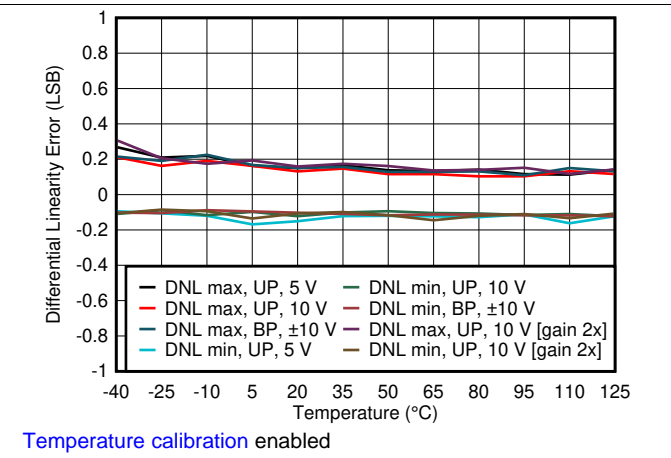
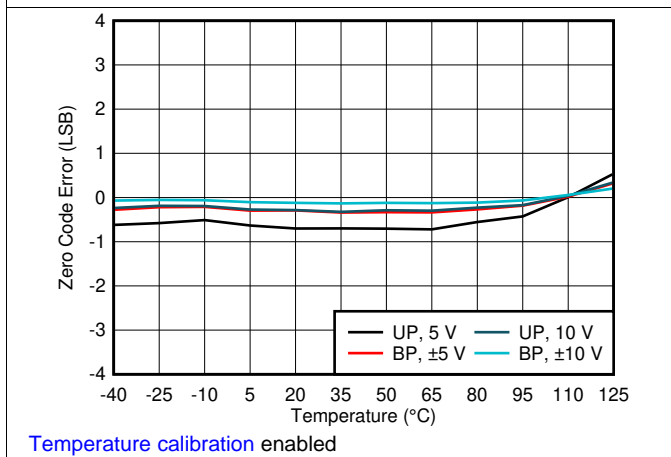

Figure 5. Integral Linearity Error vs Temperature



Temperature calibration enabled

Figure 6. Differential Linearity Error vs Temperature



Temperature calibration enabled

Figure 7. Zero Code Error vs Temperature

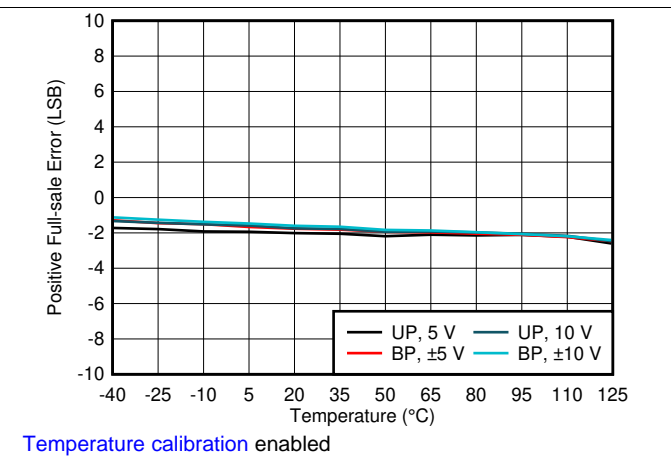

Temperature calibration enabled

Figure 8. Positive Full-Scale Error vs Temperature

Typical Characteristics (continued)

at $T_A = 25^\circ\text{C}$, $V_{CC} = 15\text{ V}$, $V_{SS} = -15\text{ V}$, $AV_{DD} = 5\text{ V}$, $IOV_{DD} = 1.8\text{ V}$, gain resistors unconnected (gain = 1x), OPA827 used as output and reference amplifier, UP = unipolar, BP = bipolar, and temperature calibration disabled (unless otherwise noted)

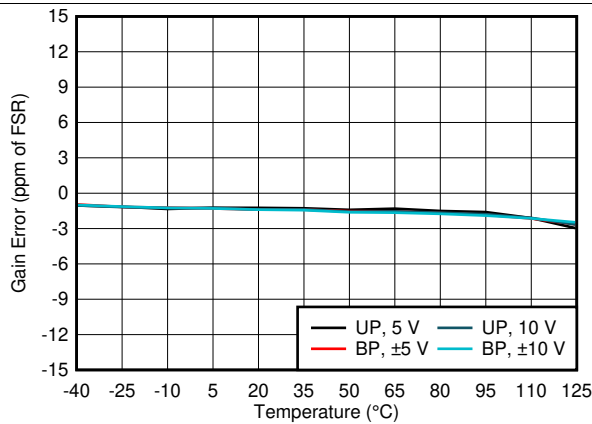

Temperature calibration enabled

Figure 9. Gain Error vs Temperature

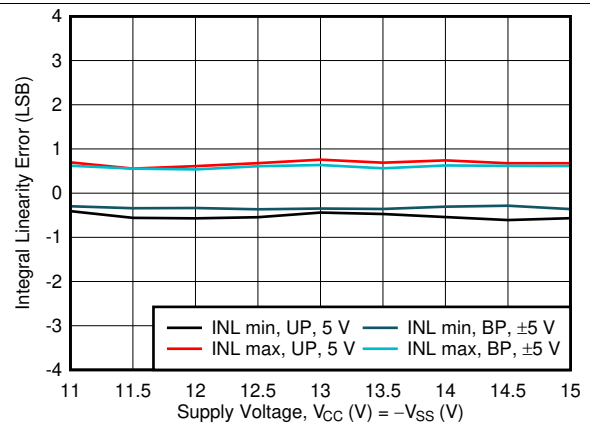

Figure 10. Integral Linearity Error vs Supply Voltage

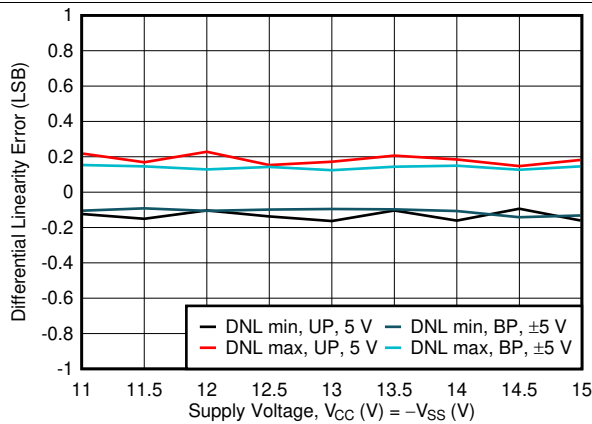

Figure 11. Differential Linearity Error vs Supply Voltage

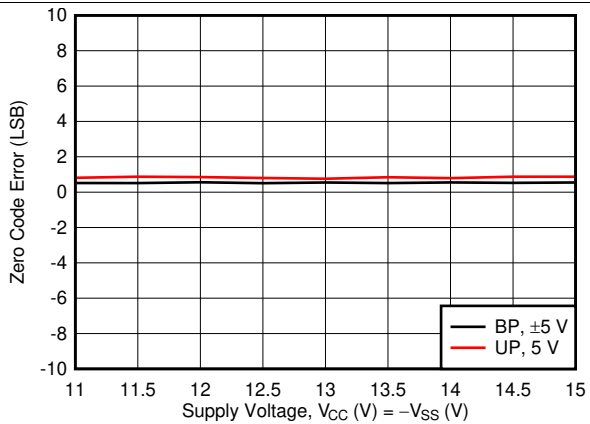

Figure 12. Zero Code Error vs Supply Voltage

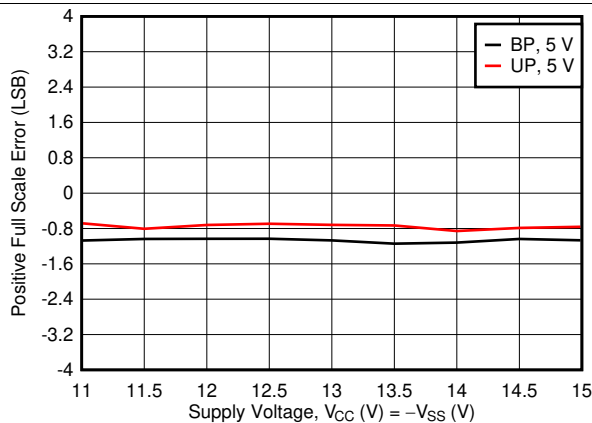

Figure 13. Positive Full-Scale Error vs Supply Voltage

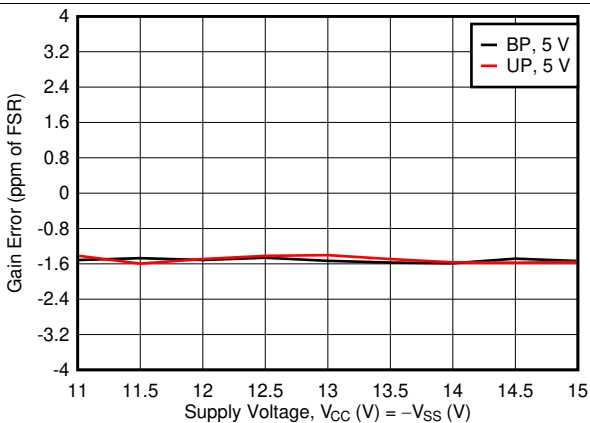

Figure 14. Gain Error vs Supply Voltage

Typical Characteristics (continued)

at $T_A = 25^\circ\text{C}$, $V_{CC} = 15\text{ V}$, $V_{SS} = -15\text{ V}$, $AV_{DD} = 5\text{ V}$, $IOV_{DD} = 1.8\text{ V}$, gain resistors unconnected (gain = 1x), OPA827 used as output and reference amplifier, UP = unipolar, BP = bipolar, and [temperature calibration](#) disabled (unless otherwise noted)

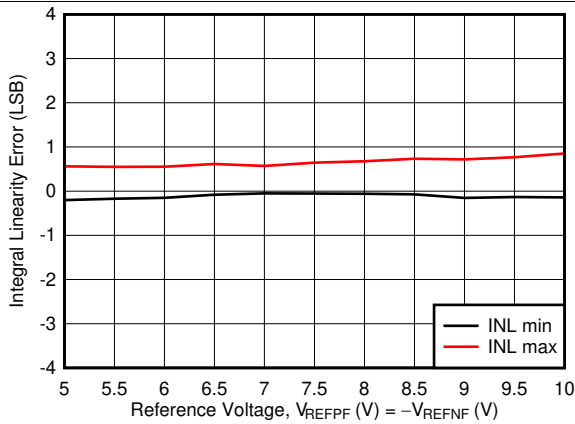

Figure 15. Integral Linearity Error vs Reference Voltage

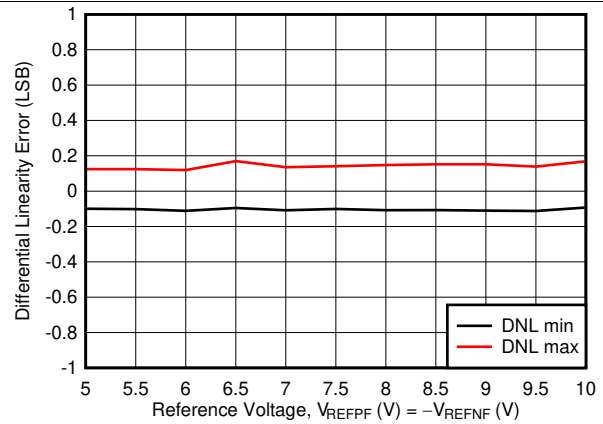

Figure 16. Differential Linearity Error vs Reference Voltage

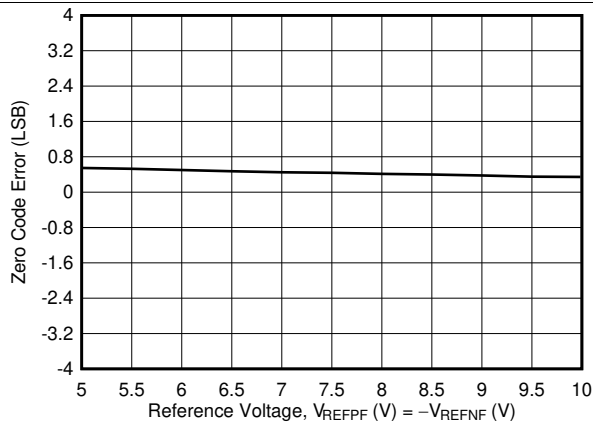

Figure 17. Zero Code Error vs Reference Voltage

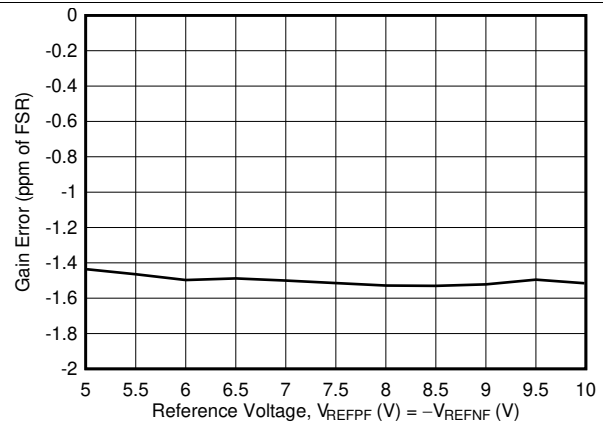

Figure 18. Gain Error vs Reference Voltage

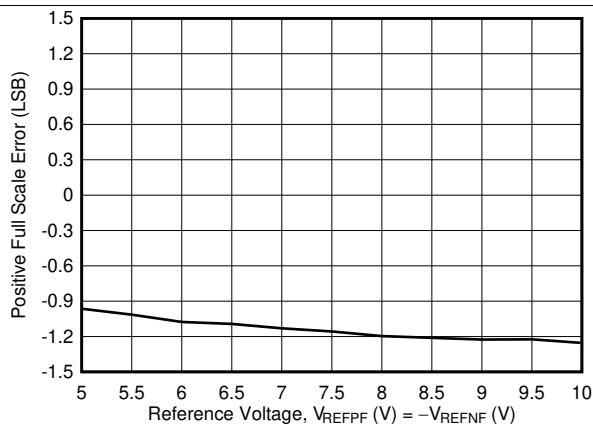

Figure 19. Positive Full-Scale Error vs Reference Voltage

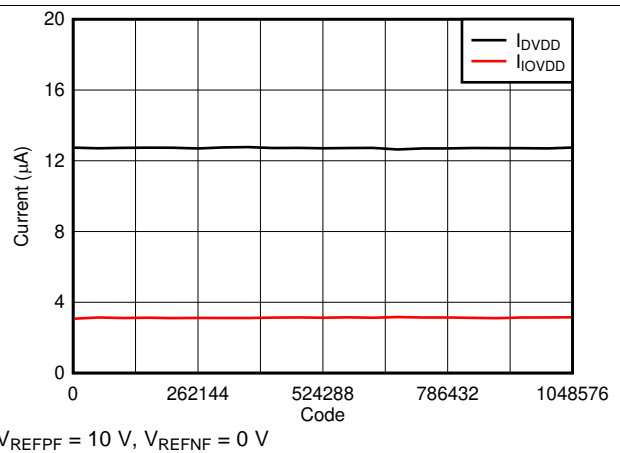
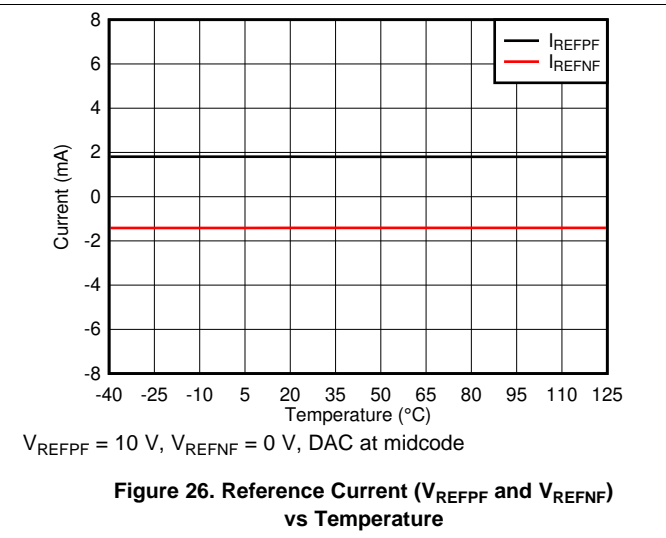
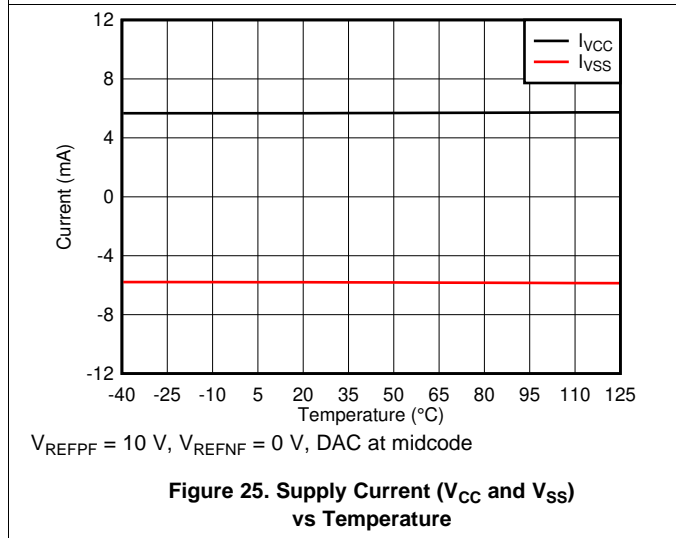
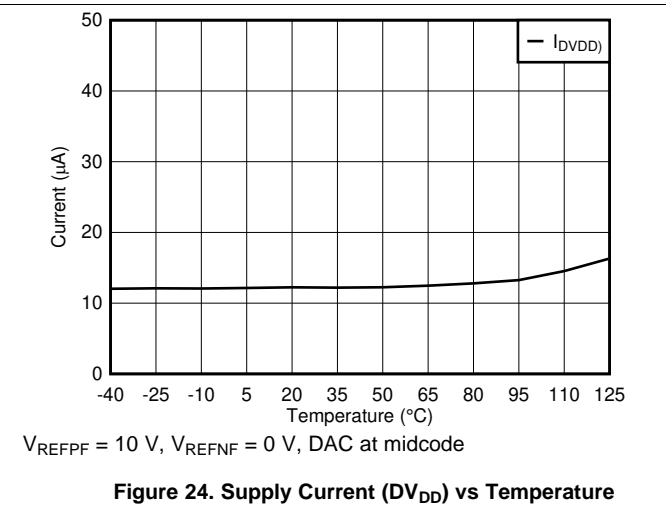
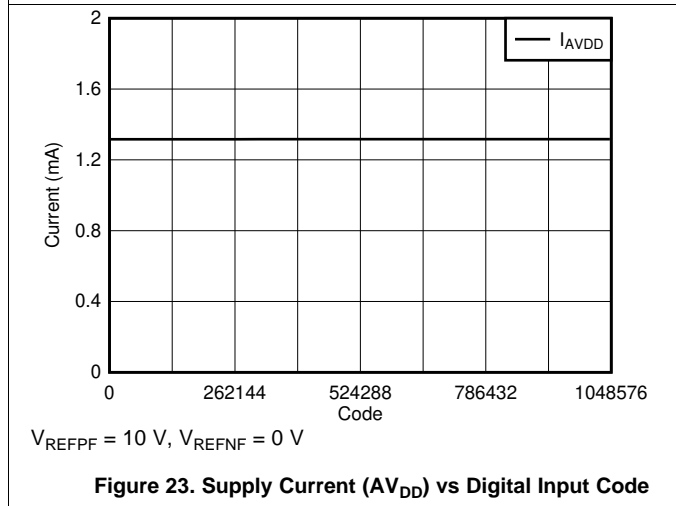
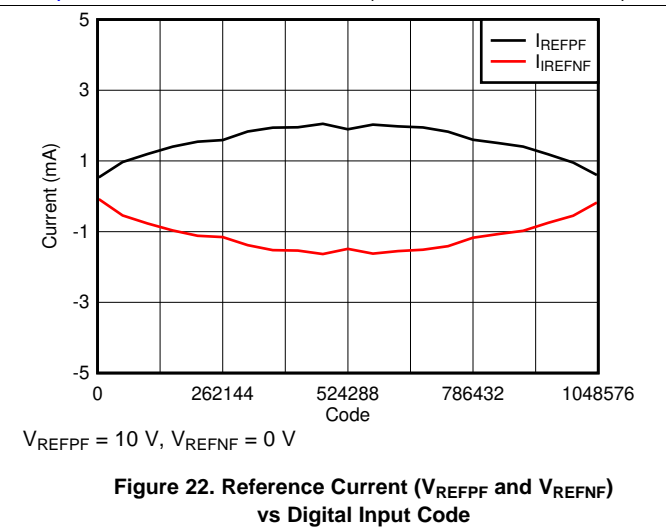
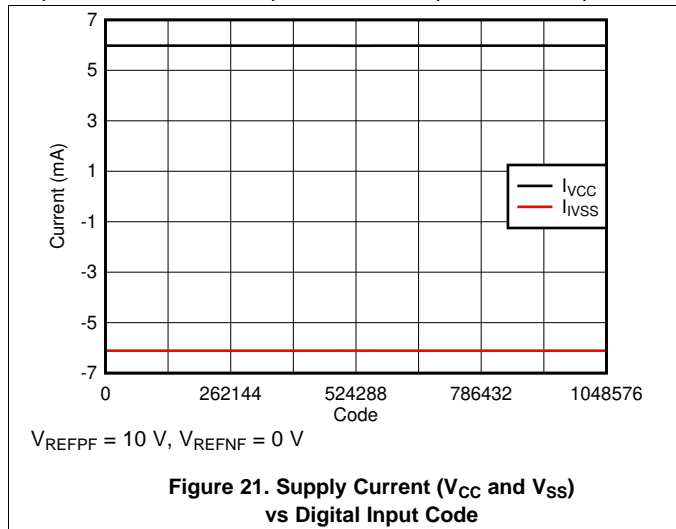

Figure 20. Supply Current (DV_{DD} and IOV_{DD}) vs Digital Input Code

Typical Characteristics (continued)

at $T_A = 25^\circ\text{C}$, $V_{CC} = 15\text{ V}$, $V_{SS} = -15\text{ V}$, $AV_{DD} = 5\text{ V}$, $IOV_{DD} = 1.8\text{ V}$, gain resistors unconnected (gain = 1x), OPA827 used as output and reference amplifier, UP = unipolar, BP = bipolar, and [temperature calibration](#) disabled (unless otherwise noted)



Typical Characteristics (continued)

at $T_A = 25^\circ\text{C}$, $V_{CC} = 15\text{ V}$, $V_{SS} = -15\text{ V}$, $AV_{DD} = 5\text{ V}$, $IOV_{DD} = 1.8\text{ V}$, gain resistors unconnected (gain = 1x), OPA827 used as output and reference amplifier, UP = unipolar, BP = bipolar, and [temperature calibration](#) disabled (unless otherwise noted)

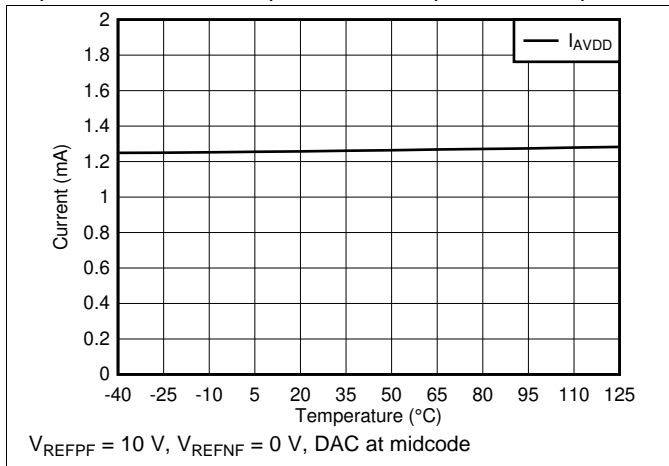

Figure 27. Supply Current (AV_{DD}) vs Temperature

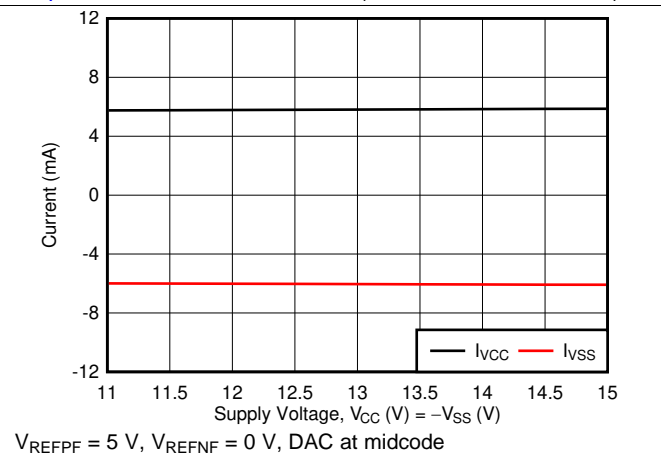

Figure 28. Supply Current (V_{CC} and V_{SS}) vs Supply Voltage

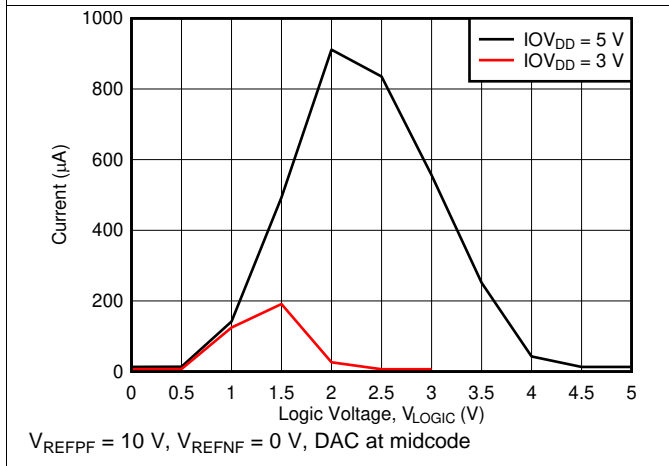

Figure 29. Supply Current (IOV_{DD}) vs Input Pin Logic Level

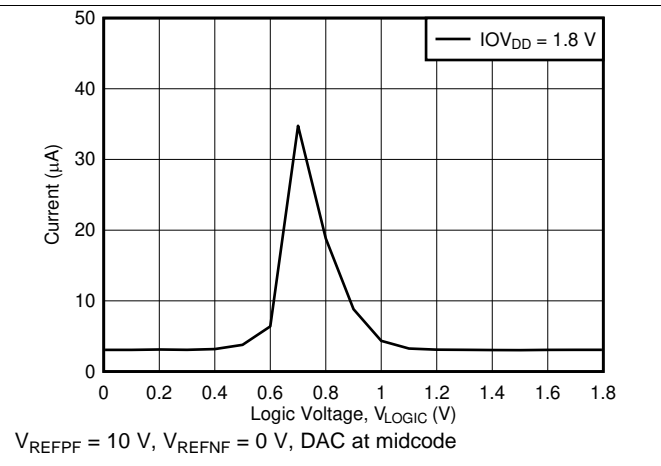

Figure 30. Supply Current ($IOV_{DD} = 1.8\text{ V}$) vs Input Pin Logic Level

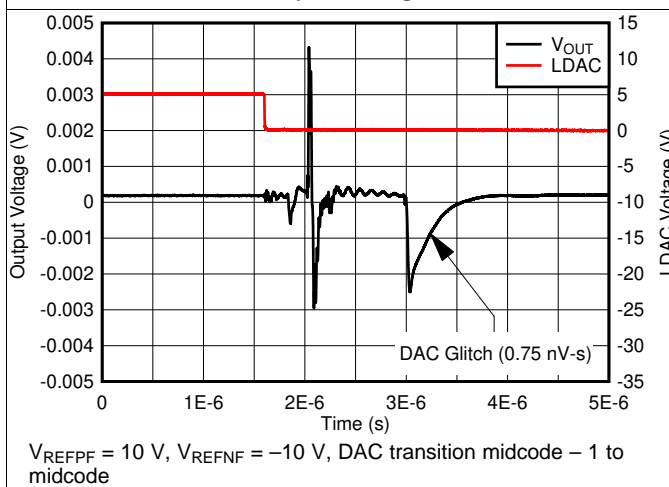

Figure 31. Glitch Impulse, Rising Edge, 1-LSB Step

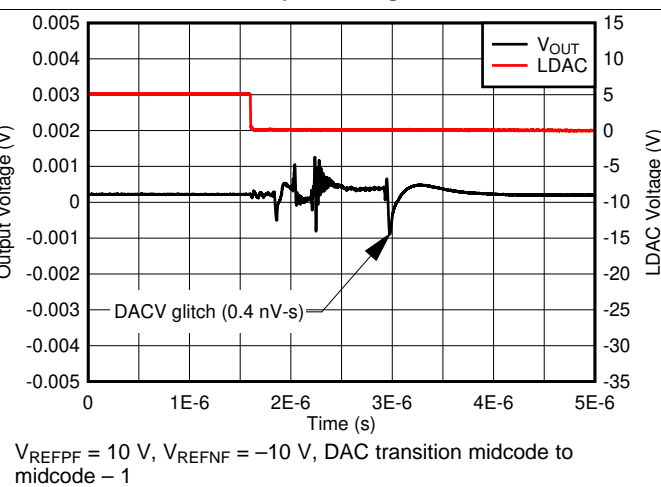
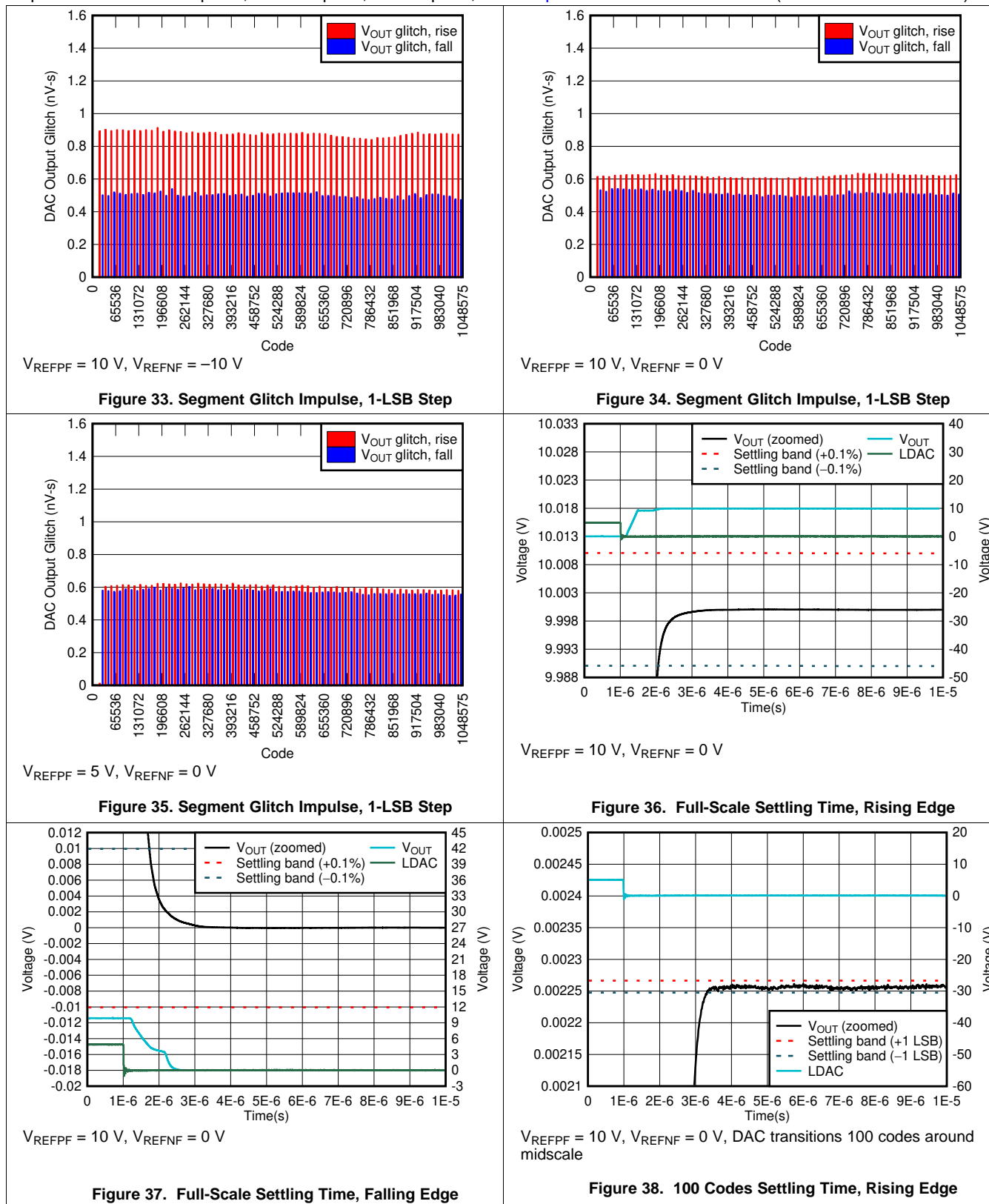

Figure 32. Glitch Impulse, Falling Edge, 1-LSB Step

Typical Characteristics (continued)

at $T_A = 25^\circ\text{C}$, $V_{CC} = 15\text{ V}$, $V_{SS} = -15\text{ V}$, $AV_{DD} = 5\text{ V}$, $IOV_{DD} = 1.8\text{ V}$, gain resistors unconnected (gain = 1x), OPA827 used as output and reference amplifier, UP = unipolar, BP = bipolar, and [temperature calibration](#) disabled (unless otherwise noted)



Typical Characteristics (continued)

at $T_A = 25^\circ\text{C}$, $V_{CC} = 15\text{ V}$, $V_{SS} = -15\text{ V}$, $AV_{DD} = 5\text{ V}$, $IOV_{DD} = 1.8\text{ V}$, gain resistors unconnected (gain = 1x), OPA827 used as output and reference amplifier, UP = unipolar, BP = bipolar, and [temperature calibration](#) disabled (unless otherwise noted)

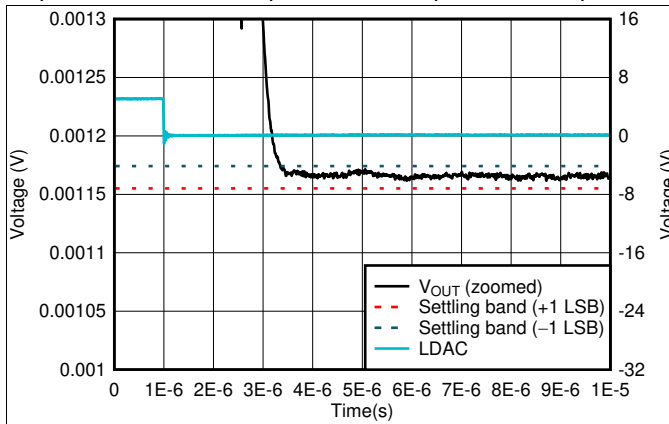

$V_{REFPF} = 10\text{ V}$, $V_{REFNF} = 0\text{ V}$, DAC transitions 100 codes around midscale

Figure 39. 100 Codes Settling Time, Falling Edge

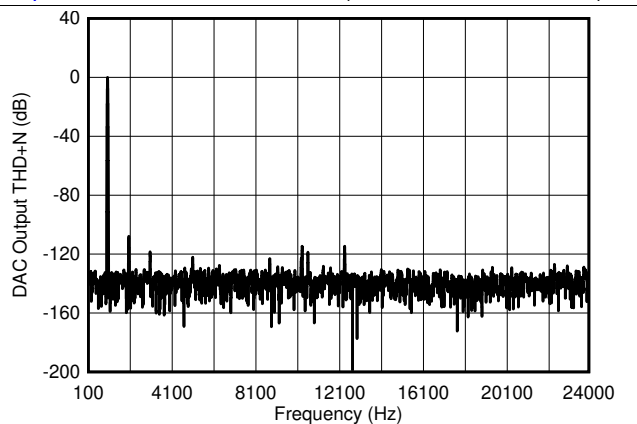

$V_{REFPF} = 10\text{ V}$, $V_{REFNF} = 0\text{ V}$, DAC output frequency = 1 kHz, DAC update rate = 400 kHz

Figure 40. Total Harmonic Distortion (THD + N) vs Frequency

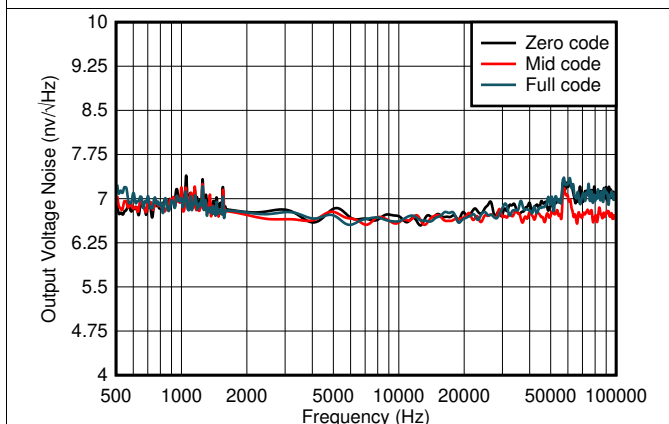

$V_{REFPF} = 10\text{ V}$, $V_{REFNF} = 0\text{ V}$, measured at DAC output

Figure 41. DAC Output Noise Spectral Density

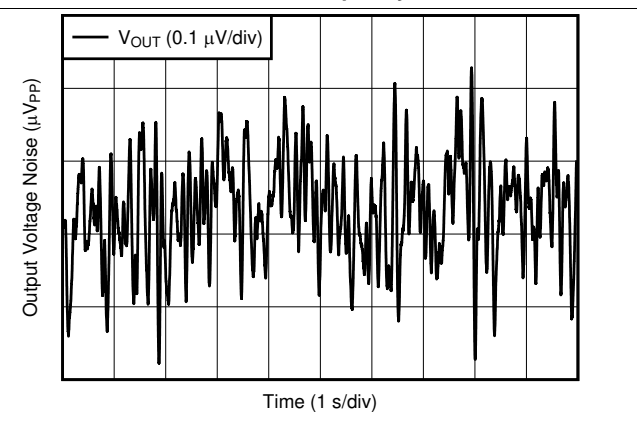

$V_{REFPF} = 10\text{ V}$, $V_{REFNF} = 0\text{ V}$, DAC at midcode, measured at DAC output pin

Figure 42. DAC Output Noise: 0.1 Hz to 10 Hz

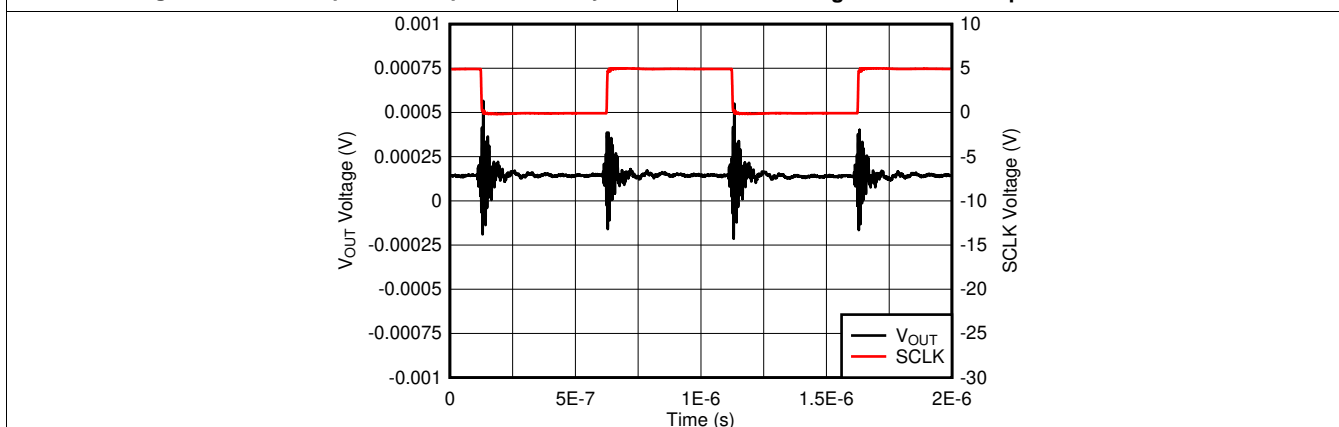

$V_{REFPF} = 10\text{ V}$, $V_{REFNF} = 0\text{ V}$, DAC at midcode, measured at DAC output pin

Figure 43. Clock Feedthrough

8 Detailed Description

8.1 Overview

The 20-bit DAC11001A, 18-bit DAC91001, and 16-bit DAC81001 (DACx1001) are single-channel DACs. The unbuffered DAC output architecture is based on an R2R ladder that is designed to provide monotonicity over wide reference and temperature ranges (1-LSB DNL). This architecture provides a very low-noise ($7 \text{ nV}/\sqrt{\text{Hz}}$) and fast-settling ($1 \mu\text{s}$) output. The DACx1001 also implement a deglitch circuit that enables low, code-independent glitch at the DAC output. This is extremely useful for creating ultra low harmonic distortion waveform generation.

The DACx1001 requires external reference voltages on REFPS and REFNF pins. The output of the DAC ranges from V_{REFNF} to V_{REFPF} . See the [Recommended Operating Conditions](#) for V_{REFPF} and V_{REFNF} voltage ranges.

The DACx1001 also includes precision matched gain setting pins (ROFS, RCM, and RFB), Using these pins and an external op amp, the DAC output can be scaled. The DACx1001 incorporate a power-on-reset circuit that makes sure that the DAC output powers up at zero scale, and remains at zero scale until a valid DAC command is issued. The DACx1001 use a 4-wire serial interface that operates at clock rates of up to 50 MHz.

8.2 Functional Block Diagram

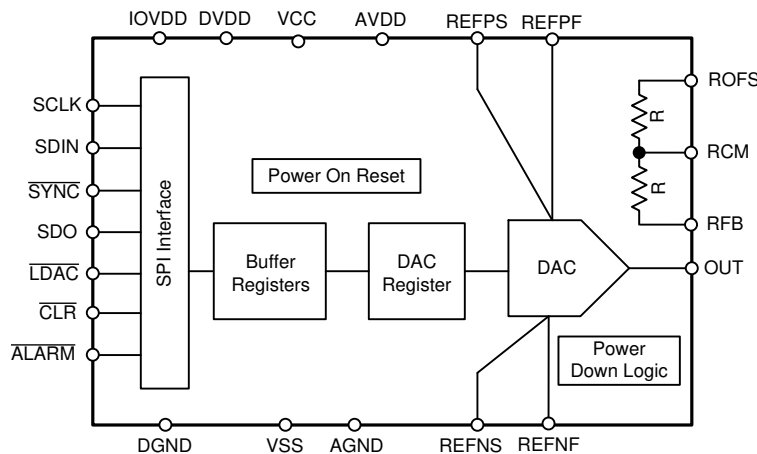

8.3 Feature Description

8.3.1 Digital-to-Analog Converter Architecture

The DACx1001 provide 20-bit monotonic outputs using an R2R ladder architecture. The DAC output ranges between V_{REFNF} and V_{REFPF} based on the 20-bit DAC data, as described in [Equation 1](#):

$$V_{\text{OUT}} = (V_{\text{REFPF}} - V_{\text{REFNF}}) \times \frac{\text{CODE}}{2^N} + V_{\text{REFNF}}$$

where

- CODE is the decimal equivalent of the DAC-DATA loaded to the DAC.
- N is the bits of resolution; 20 for DAC1101A, 18 for DAC91001, 16 for DAC81001.
- V_{REFPF} , V_{REFNF} is the reference voltage (positive and negative).

(1)

Feature Description (continued)

8.3.2 External Reference

The DACx1001 require external references (REFPF and REFNF) to operate. See the [Recommended Operating Conditions](#) for V_{REFPF} and V_{REFNF} voltage ranges.

The DACx1001 also contain dedicated sense pins, REFPS for REFPF and REFNS for REFNF. The reference pins are unbuffered; therefore, use a reference driver circuit for these pins. Set the VREFVAL bits (address 02h) as per a reference span equal to $(V_{REFPF} - V_{REFNF})$. For example, the VREFVAL bits must be set to 0100 for $V_{REFPF} = 5\text{ V}$ and $V_{REFNF} = -5\text{ V}$.

Figure 44 shows an example reference drive circuit for DACx1001. Table 1 shows the op-amp options for the reference driver circuit.

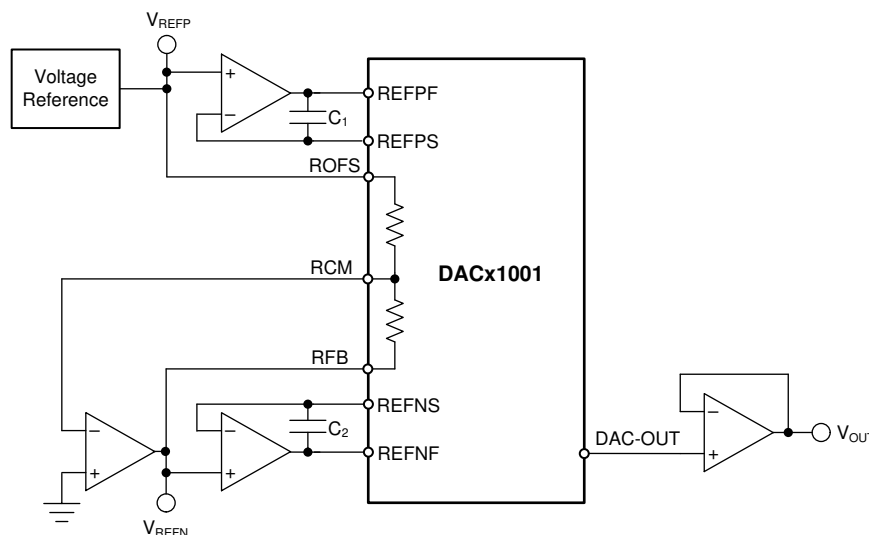

Figure 44. Reference Drive Circuit

Table 1. Reference Op Amp Options

SELECTION PARAMETERS	OP AMPS
Low voltage and current noise	OPA211, OPA827, OPA828
Low offset and drift	OPA189

8.3.3 Output Buffers

The DACx1001 outputs are unbuffered. Use an external op amp to buffer the DAC output. The DAC output voltage ranges from V_{REFPF} to V_{REFNF} . Two gain-setting resistors are integrated in the DACx1001. These resistors are used to scale the DAC output, minimize the bias current mismatch of the external op amp, and generate a negative reference for the REFNF pin. See the [Embedded Resistor Configurations](#) section for more information. Table 2 shows the op amp options for the output drive circuit.

Table 2. Output Op Amp Options

SELECTION PARAMETERS	OP AMPS
Low bias current	OPA827, OPA828
Low noise	OPA211, OPA828
Low offset and drift	OPA189
Fast settling and low THD	OPA827, OPA828, OPA1612, THS4011

8.3.4 Internal Power-On Reset (POR)

The DACx1001 incorporate two internal POR circuits for the DV_{DD} , AV_{DD} , IOV_{DD} , V_{CC} , and V_{SS} supplies. The POR signals are ANDed together, so that all supplies must be at the minimal specified values for the device to *not* be in a reset condition. These POR circuits initialize internal registers, as well as set the analog outputs to a known state while the device supplies are ramping. All registers are reset to default values. The DACx1001 power on with the DAC registers set to zero scale. The DAC can be powered down by writing 1 to PDN (bit 4, address 02h). Typically, the POR function can be ignored as long as the device supplies power up and maintain the specified minimum voltage levels. However, in the case of supply drop or brownout, the DACx1001 can have an internal POR reset event. Figure 45 represents the internal POR threshold levels for the DV_{DD} , AV_{DD} , IOV_{DD} , V_{CC} , and V_{SS} supplies.

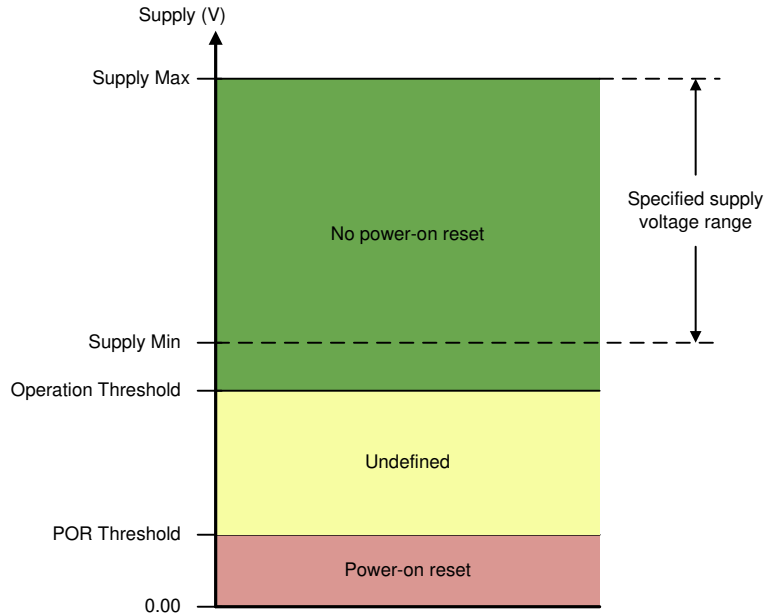

Figure 45. Relevant Voltage Levels for the POR Circuit

For the DV_{DD} supply, no internal POR occurs for nominal supply operation from 2.7 V (supply minimum) to 5.5 V (supply maximum). For a DV_{DD} supply region between 2.5 V (undefined operation threshold) and 1.6 V (POR threshold), the internal POR circuit may or may not provide a reset over all temperature conditions. For a DV_{DD} supply less than 1.6 V (POR threshold), the internal POR resets as long as the supply voltage is less than 1.6 V for approximately 1 ms.

For the AV_{DD} supply, no internal POR occurs for nominal supply operation from 4.5 V (supply minimum) to 5.5 V (supply maximum). For an AV_{DD} supply region between 4.1 V (undefined operation threshold) and 3.3 V (POR threshold), the internal POR circuit may or may not provide a reset over all temperature conditions. For an AV_{DD} supply less than 3.3 V (POR threshold), the internal POR resets as long as the supply voltage is less than 3.3 V for approximately 1 ms.

For the V_{CC} supply, no internal POR occurs for nominal supply operation from 8 V (supply minimum) to 36 V (supply maximum). For V_{CC} supply voltages between 7.5 V (undefined operation threshold) to 6 V (POR threshold), the internal POR circuit may or may not provide a reset over all temperature conditions. For a V_{CC} supply less than 6 V (POR threshold), the internal POR resets as long as the supply voltage is less than 6 V for approximately 1 ms.

For the V_{SS} supply, no internal POR occurs for nominal supply operation from -3 V (supply minimum) to -18 V (supply maximum). For V_{SS} supply voltages between -2.7 V (undefined operation threshold) to -1.8 V (POR threshold), the internal POR circuit may or may not provide a reset over all temperature conditions. For a V_{SS} supply greater than -1.8 V (POR threshold), the internal POR resets as long as the supply voltage is greater than -1.8 V for approximately 1 ms.

For the IOV_{DD} supply, no internal POR occurs for nominal supply operation from 1.8 V (supply minimum) to 5.5 V (supply maximum). For IOV_{DD} supply voltages between 1.5 V (undefined operation threshold) and 0.8 V (POR threshold), the internal POR circuit may or may not provide a reset over all temperature conditions. For an IOV_{DD} supply less than 0.8 V (POR threshold), the internal POR resets as long as the supply voltage is less than 0.8 V for approximately 1 ms.

In case the DV_{DD}, AV_{DD}, IOV_{DD}, V_{CC}, or V_{SS} supply drops to a level where the internal POR signal is indeterminate, power cycle the device followed by a software reset.

8.3.5 Temperature Drift and Calibration

The DACx1001 includes a calibration circuit that significantly reduces the temperature drift on integrated and differential nonlinearities. By default, this feature is disabled. Enable the temperature calibration feature by writing 1 to the EN_TMP_CAL bit (address 02h, B23). After the EN_TMP_CAL bit is set, issue a calibration cycle by writing 1 to RCLTMP (address 04h, B8). At this point, the device enters a calibration cycle. Do not issue any DAC update command during this period. The device has the capability to indicate the end of calibration using two methods:

1. Read the status bit ALM (address 05h, B12) using SPI.
2. Issue an alarm on the ALARM pin by setting logic 0. To enable this feature, write 1 to ENALMP bit (address 02h, B12).

After the calibration cycle completes, update the DAC code to observe the impact at the DAC output. If the environmental temperature changes after calibration, then recalibrate the device.

8.3.6 DAC Output Deglitch Circuit

The DACx1001 include a deglitch (track-and-hold) circuit at the output. This circuit is enabled by default. The deglitch circuit minimizes the code-to-code glitch at the DAC output at the expense of the DAC update rate. This circuit is disabled by writing 1 to DIS_TNH (bit 7, address 06h). Disable this circuit to enable faster update of the DAC output, but with higher code-to-code glitches.

8.4 Device Functional Modes

8.4.1 Fast-Settling Mode and THD

The DACx1001 R2R ladder and deglitch circuit reduce the harmonic distortion for waveform generation applications. The fast settling bit (FSET, bit 10, address 02h) is set to 1 by default, so that the DAC is configured for enhanced THD performance. The FSET bit can be reset to 0 using an SPI write to enable fast-settling mode. In this mode, the DAC deglitcher circuit can be configured using TNH_MASK (bits 19:18, address 02h). These bits disable the deglitch circuit for code changes specified in [Table 7](#). These bits are only writable when FSET = 0 (fast settling enabled) and DIS_TNH = 0 (deglitch circuit enabled).

8.4.2 DAC Update Rate Mode

The DACx1001 maximum update rate can be configured up to 1 MHz by using UP_RATE (bits 6:4, address 06h). These bits change the hold timing of the deglitch circuit. The bits are set to a 0.5-MHz DAC update rate by default for enhanced THD performance. Changing the maximum update rate of the DAC impacts THD performance.

8.5 Programming

The DACx1001 family of devices is controlled through a flexible four-wire serial interface that is compatible with serial interfaces used on many microcontrollers and DSP controllers. The interface provides read and write access to all registers of the DACx1001 devices. Additionally, the interface can be configured to daisy-chain multiple devices for write operations.

Each serial interface access cycle is exactly 32 bits long, as shown in Figure 46. A frame is initiated by asserting SYNC pin low. The frame ends when the SYNC pin is deasserted high. The first bit is read/write bit B31. A write is performed when this bit is set to 0, and a read is performed when this bit is set to 1. The next 7 bits are address bits B30 to B24. The next 20 bits are data. For all writes, data are clocked on the falling edge of SCLK. As Figure 47 shows, for read access and daisy-chain operation, the data are clocked out on the SDO terminal on the rising edge of SCLK.

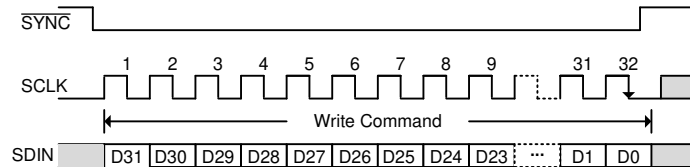

Figure 46. Serial Interface Write Bus Cycle: Standalone Mode

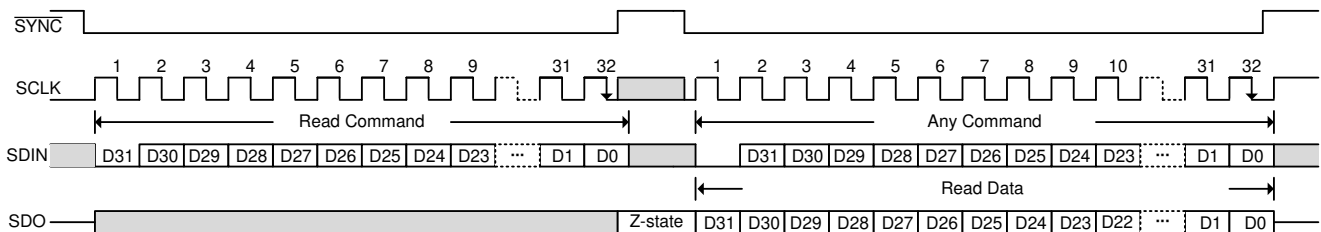

Figure 47. Serial Interface Read Bus Cycle

8.5.1 Daisy-Chain Operation

For systems that contain several DACx1001 devices, the SDO pin is used to daisy-chain the devices together. The daisy-chain feature is useful in reducing the number of serial interface lines. The first falling edge on the SYNC pin starts the operation cycle, as shown in Figure 48. SCLK is continuously applied to the input shift register while the SYNC pin is kept low. The DAC is updated with the data on rising edge of SYNC pin.

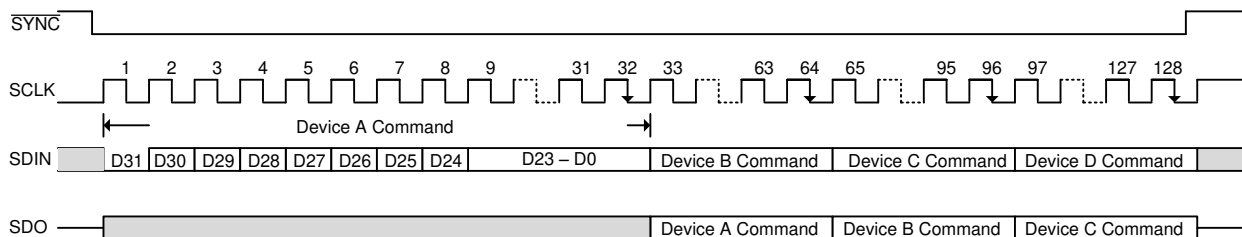

Figure 48. Serial Interface Daisy-Chain Write Cycle

If more than 32 clock pulses are applied, the data ripple out of the shift register and appear on the SDO line. These data are clocked out on the rising edge of SCLK and are valid on the falling edge. By connecting the SDO output of the first device to the SDI input of the next device in the chain, a multiple-device interface is constructed. Each device in the system requires 32 clock pulses.

Programming (continued)

As a result, the total number of clock cycles must be equal to $32 \times N$, where N is the total number of devices in the daisy-chain. When the serial transfer to all devices is complete the $\overline{\text{SYNC}}$ signal is taken high. This action transfers the data from the SPI shift registers to the internal register of each device in the daisy-chain and prevents any further data from being clocked into the input shift register. The DACx1001 implement a bit that enables higher speeds for clocking out data from the SDO pin. Enable this feature by setting FSDO (bit 13, address 02h) to 1. See [Timing Requirements: Read and Daisy-Chain Write, \$2.7 \text{ V} \leq \text{DV}_{\text{DD}} < 4.5 \text{ V}\$](#) and [Timing Requirements: Read and Daisy-Chain Write, \$4.5 \text{ V} \leq \text{DV}_{\text{DD}} \leq 5.5 \text{ V}\$](#) for more information.

8.5.2 $\overline{\text{CLR}}$ Pin Functionality and Software Clear

The $\overline{\text{CLR}}$ pin is an asynchronous input pin to the DAC. When activated, this level-sensitive pin clears the DAC buffers and DAC latches to the DAC-CLEAR-DATA bits (address 03h). The device exits clear mode on the $\overline{\text{SYNC}}$ rising edge of the next valid write to the device. If the $\overline{\text{CLR}}$ pin receives a logic 0 during a write sequence during normal operation, the clear mode is activated and the buffer and DAC registers are immediately cleared. The DAC registers can also be cleared using the SCLR bit (address 04h, B5); the contents are cleared at the rising edge of $\overline{\text{SYNC}}$.

8.5.3 Output Update (Synchronous and Asynchronous)

The DACx1004 devices offer both a software and hardware simultaneous update and control function. The DAC double-buffered architecture has been designed so that new data can be entered for the DAC without disturbing the analog output. Data updates can be performed either in synchronous or in asynchronous mode, depending on the status of LDAC-MODE bit (address 02h, B14).

8.5.3.1 Synchronous Update

In synchronous mode (LDACMODE = 1), the $\overline{\text{LDAC}}$ pin is used as an active-low signal for simultaneous DAC updates. Data buffers must be loaded with the desired data before an $\overline{\text{LDAC}}$ low pulse. After an $\overline{\text{LDAC}}$ low pulse, the DAC is updated with the last contents of the corresponding data buffers. If the content of a data buffer is not changed, the DAC output remains unchanged after the $\overline{\text{LDAC}}$ pin is pulsed low.

8.5.3.2 Asynchronous Update

In asynchronous mode (LDACMODE = 0), data are updated with the rising edge of the $\overline{\text{SYNC}}$ (when daisy-chain mode is enabled, DSDO = 0), or at the 32nd falling edge of SCLK (When daisy-chain mode is disabled, DSDO = 1). For asynchronous updates, the $\overline{\text{LDAC}}$ pin is not required, and must be connected to 0 V permanently.

8.5.4 Software Reset Mode

The DACx1001 implements a software reset feature. The software reset function uses the SRST bit (address 04h, B6). When this bit is set to 1, the device resets to the default state.

8.6 Register Map

Table 3. Register Map

REGISTER NAME	BIT																							
	31	30-24	23	22	21	20	19	18	17	16	15	14	13	12	11	10	9	8	7	6	5	4	3-0	
NOP	\overline{W}	00h	NOP																				0h	
DAC-DATA	R/ \overline{W}	01h	DAC-DATA (20 bits, 18 bits, or 16 bits, left-justified)																				0h	
CONFIG1	R/ \overline{W}	02h	EN_TMP_CAL	0h	TNH_MASK	0h	LDAC MODE	FSDO	ENALMP	DSDO	FSET	VREFVAL				0	PDN	0h						
DAC-CLEAR-DATA	R/ \overline{W}	03h	DAC-CLEAR-DATA (8 bits left justified)								000h												0h	
TRIGGER	R/ \overline{W}	04h	0000h														RCLTMP	0	SRST	SCLR	0	0h		
STATUS	R	05h	000h								ALM	00h												0h
CONFIG2	R/ \overline{W}	06h	0000h														DIS_TNH	TNH_SETTING				0h		

Table 4. Access Type Codes

Access Type	Code	Description
Read Type		
R	R	Read
Write Type		
W	W	Write
Reset or Default Value		
-n		Value after reset or the default value

8.6.1 NOP Register (address = 00h) [reset = 0x000000h]

Figure 49. NOP Register Format

31	30	29	28	27	26	25	24	23	22	21	20	19	18	17	16
Read/Write		Address							NOP						
\overline{W}		W							W						
15	14	13	12	11	10	9	8	7	6	5	4	3	2	1	0
NOP												0h			
W												W			

Table 5. NOP Register Field Descriptions

Bit	Field	Type	Reset	Description
31	Write	W	N/A	Write when set to 0
30:24	Address	W	N/A	00h
23:4	NOP	W	00000h	No operation - Write 00000h
3:0	0h	W	N/A	N/A

8.6.2 DAC-DATA Register (address = 01h) [reset = 0x000000h]

Figure 50. DAC-DATA Register Format

31	30	29	28	27	26	25	24	23	22	21	20	19	18	17	16
Read/Write		Address							DAC-DATA (20-bit, 18-bit, or 16-bit, left justified)						
R/ \overline{W}		W							R/W						
15	14	13	12	11	10	9	8	7	6	5	4	3	2	1	0
DAC-DATA (20-bit, 18-bit, or 16-bit, left justified)												0h			
R/W												W			

Table 6. DAC-DATA Register Field Descriptions

Bit	Field	Type	Reset	Description
31	Read/Write	R/ \overline{W}	N/A	Read when set to 1 or write when set to 0
30:24	Address	W	N/A	01h
23:4	DAC-DATA[19:0]	R/W	0h	Stores the 20-bit, 18-bit, or 16-bit data to be loaded to DAC in MSB aligned straight binary format. Data follows the format below: DAC1101A: { DAC-DATA[19:0] } DAC91001: { DAC-DATA[17:0], 0, 0 } DAC81001: { DAC-DATA[15:0], 0, 0, 0, 0 }
3:0	0h	W	N/A	N/A

8.6.3 CONFIG1 Register (address = 02h) [reset = 004C80h for bits [23:0]]
Figure 51. CONFIG1 Register Format

31	30	29	28	27	26	25	24	23	22	21	20	19	18	17	16
Read/Write	Address							EN_TMP_CAL	0h			TNH_MASK		0h	
R/W	W							R/W	W			R/W		W	
15	14	13	12	11	10	9	8	7	6	5	4	3	2	1	0
0h	LDAC MODE	FSDO	ENALMP	DSDO	FSET	VREFVAL			0h	PDN	0h				
W				R/W				W			R/W	W			

Table 7. CONFIG1 Register Field Descriptions

Bit	Field	Type	Reset	Description
31	Read/Write	R/W	N/A	Read when set to 1 or write when set to 0
30:24	Address	W	N/A	02h
23	EN_TMP_CAL	R/W	0h	Enables and disables the temperature calibration feature 0 : Temperature calibration feature disabled (default) 1 : Temperature calibration feature enabled
22:20	0h	W	N/A	N/A
19-18	TNH_MASK	R/W	0h	Mask track and hold (TNH) circuit. This bit is writable only when FSET = 0 [fast-settling mode] and DIS_TNH = 0 [track-and-hold enabled] 00: TNH masked for code jump > 2 ¹⁴ (default) 01: TNH masked for code jump > 2 ¹⁵ 10: TNH masked for code jump > 2 ¹³ 11: TNH masked for code jump > 2 ¹²
17:15	0h	W	N/A	N/A
14	LDACMODE	R/W	1	Synchronous or asynchronous mode select bit 0 : DAC output updated on SYNC rising edge 1 : DAC updated on LDAC falling edge (default)
13	FSDO	R/W	0h	Enable Fast SDO 0 : Fast SDO disabled (Default) 1 : Fast SDO enabled
12	ENALMP	R/W	0h	Enable ALARM pin to be pulled low, end of temperature calibration cycle 0 : No alarm on the ALARM pin 1 : Indicates end of temperature calibration cycle. ALARM pin pulled low.
11	DSDO	R/W	1h	Enable SDO (for readback and daisy-chain) 1 : SDO enabled (default) 0 : SDO disabled
10	FSET	R/W	1h	Fast-settling vs enhanced THD mode 0 : Fast settling 1 : Enhanced THD (default)
9:6	VREFVAL	R/W	2h	Reference span value bits 0000: Invalid 0001: Invalid 0010: Reference span = 5 V ± 1.25 V (default) 0011: Reference span = 7.5 V ± 1.25 V 0100: Reference span = 10 V ± 1.25 V 0101: Reference span = 12.5 V ± 1.25 V 0110: Reference span = 15 V ± 1.25 V 0111: Reference span = 17.5 V ± 1.25 V 1000: Reference span = 20 V ± 1.25 V 1001: Reference span = 22.5 V ± 1.25 V 1010: Reference span = 25 V ± 1.25 V 1011: Reference span = 27.5 V ± 1.25 V 1100: Reference span = 30 V ± 1.25 V
5	0	W	N/A	N/A
4	PDN	R/W	0h	Powers down and power up the DAC 0 : DAC power up (default) 1 : DAC power down
3:0	0000	R/W	N/A	N/A

8.6.4 DAC-CLEAR-DATA Register (address = 03h) [reset = 000000h for bits [23:0]]

Figure 52. DAC-CLEAR-DATA Register Format

31	30	29	28	27	26	25	24	23	22	21	20	19	18	17	16
Read/Write	Address							DAC-CLEAR-DATA (8 bits, left justified)							
R/W	W							R/W							
15	14	13	12	11	10	9	8	7	6	5	4	3	2	1	0
000h											0h				
W											W				

Table 8. DAC-CLEAR-DATA Register Field Descriptions

Bit	Field	Type	Reset	Description
31	Read/Write	R/W	N/A	Read when set to 1 or write when set to 0
30:24	Address	W	N/A	03h
23:16	DAC-CLEAR-DATA	R/W	00h	Stores the 8-bit data to be loaded to DAC in left-justified, straight-binary format. DAC data registers updated with this value when CLR pin asserted low
15:0	000h	W	N/A	N/A

8.6.5 TRIGGER Register (address = 04h) [reset = 000000h for bits [23:0]]

Figure 53. TRIGGER Register Format

31	30	29	28	27	26	25	24	23	22	21	20	19	18	17	16
Read/Write	Address							00h							
R/W	W							W							
15	14	13	12	11	10	9	8	7	6	5	4	3	2	1	0
00h							RCLTMP	0h	SRST	SCLR	0h	0h			
W							R/W	W	R/W	R/W	W	W			

Table 9. TRIGGER Register Field Descriptions

Bit	Field	Type	Reset	Description
31	Read/Write	R/W	N/A	Read when set to 1 or write when set to 0
30:24	Address	W	N/A	04h
23:9	0000h	W	N/A	Unused
8	RCLTMP	R/W	0h	Trigger temperature recalibration DAC Codes 0 : No temperature recalibration (default) 1 : DAC codes recalibrated, ALARM pin is pulled low (if ENALMP = 1) and ALM bit (Address 05) is set 1 upon calibration completion. Subsequent DAC codes will use latest calibrated coefficients.
7	0h	W	N/A	NA
6	SRST	R/W	0h	Software reset 0 : No software reset (default) 1 : Software reset initiated, device in default state
5	SCLR	R/W	0h	Software clear 0 : No software clear (default) 1 : Software clear initiated, DAC registers in clear mode, DAC code set by clear select register (address 03h). DAC output clears on 32nd SCLK falling (DSDO = 1) or SYNC rising edge (DSDO = 0)
4	0h	W	N/A	N/A
3:0	0h	W	N/A	N/A

8.6.6 STATUS Register (address = 05h) [reset = 000000h for bits [23:0]]
Figure 54. STATUS Register Format

31	30	29	28	27	26	25	24	23	22	21	20	19	18	17	16
Read/Write	Address							00h							
R	W							W							
15	14	13	12	11	10	9	8	7	6	5	4	3	2	1	0
0h			ALM	00h							0h				
W			R	W							W				

Table 10. STATUS Register Field Descriptions

Bit	Field	Type	Reset	Description
31	Read/Write	R	N/A	Read when set to 1 , read only
30:24	Address	W	N/A	05h
23:13	000h	W	N/A	N/A
12	ALM	R	0	Alarm indicator bit, This bit is not masked by ENALMP bit 0 : Temperature recalibration in progress 1 : DAC codes recalibrated, ALARM pin is pulled low (if ENALMP = 1) Subsequent DAC codes will use latest calibrated coefficients. Reading back this register resets ALARM pin to 1 status.
11:4	00h	W	N/A	N/A
3:0	0h	W	N/A	N/A

8.6.7 CONFIG2 Register (address = 06h) [reset = 000040h for bits [23:0]]
Figure 55. CONFIG2 Register Format

31	30	29	28	27	26	25	24	23	22	21	20	19	18	17	16
Read/Write	Address							00h							
R/W	W							W							
15	14	13	12	11	10	9	8	7	6	5	4	3	2	1	0
00h								DIS_TNH	UP_RATE			0h			
W								R/W	R/W			W			

Table 11. CONFIG2 Register Field Descriptions

Bit	Field	Type	Reset	Description
31	Read/Write	R/W	N/A	Read when set to 1 or write when set to 0
30:24	Address	W	N/A	06h
23:8	0000h	W	N/A	N/A
7	DIS_TNH	R/W	0h	Disable track and hold: 0 : Track and hold enabled (default) 1 : Track and hold disabled
6-4	UP_RATE	R/W	4h	DAC output max update rate: 000: 1 MHz with 38-MHz SCLK 001: 0.9 MHz with 34-MHz SCLK 010: 0.8 MHz with 31-MHz SCLK 011: 1.2 MHz with 45-MHz SCLK 100: 0.5 MHz with 21-MHz SCLK, (default) 101: 0.45 MHz with 18-MHz SCLK 110: 0.4 MHz with 16-MHz SCLK 111: 0.6 MHz with 24-MHz SCLK
3:0	0h	W	N/A	N/A

9 Application and Implementation

NOTE

Information in the following applications sections is not part of the TI component specification, and TI does not warrant its accuracy or completeness. TI's customers are responsible for determining suitability of components for their purposes. Customers should validate and test their design implementation to confirm system functionality.

9.1 Application Information

The DACx1001 family of DACs are targeted for high-precision applications where ultra-high dc accuracy, ultra-low noise, fast settling, or high total harmonic distortion (THD) is required. The DACx1001 provides 20-bit monotonic resolution. This device finds application in high-performance source measure unit (SMU), battery test equipment (BTE), arbitrary waveform generation (AWG), and closed-loop control applications such as microelectromechanical system (MEMS) actuators, linear actuators, precision motor control, lens autofocus control in precision microscopy, lens control in mass spectrometer, beam control in electron beam lithography, and so on.

9.2 Typical Application

9.2.1 Source Measure Unit (SMU)

A source measure unit (SMU) is a common building block in memory and semiconductor test equipment and bench-top source measure units. A DAC is used in an SMU to force a desired voltage or a current to a device-under-test (DUT). [Figure 56](#) provides a simplified circuit diagram of the force-DAC in an SMU.

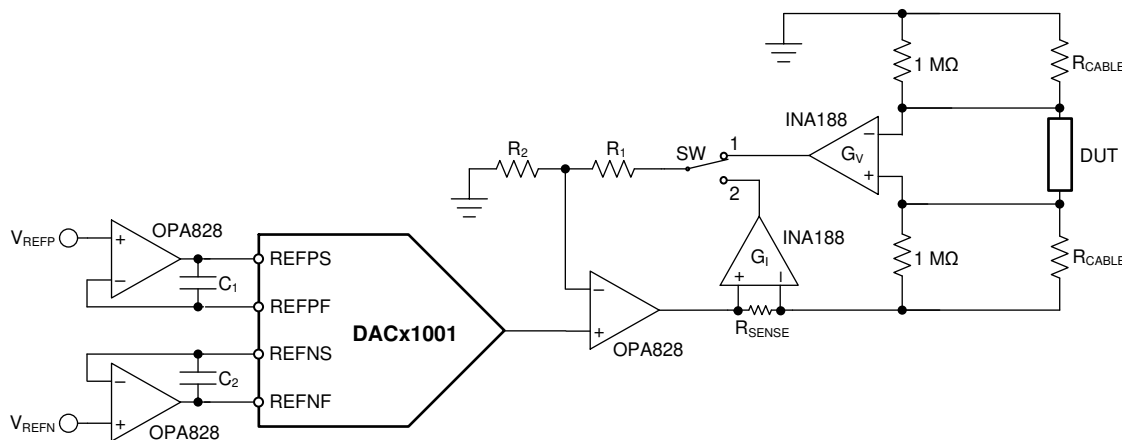

Figure 56. Source Measure Unit

9.2.1.1 Design Requirements

- Force voltage range: ± 10 V
- Force current range: ± 20 mA

9.2.1.2 Detailed Design Procedure

The DAC11001A is an excellent choice for this application to meet the 20-bit resolution requirement. Switch SW is used to toggle between force-voltage and force-current modes, as shown in [Figure 56](#). The OPA828 is a high-precision amplifier that provides a good balance between dc and ac performance, and can supply ± 30 -mA output current. The INA188 is a zero-drift instrumentation amplifier with gain selected with an external resistor. The external resistor is not shown in the drawing for simplicity. The gain resistor is not required for a gain of 1. [Equation 2](#) shows the calculation of the voltage gain when switch SW is in position 1.

$$A_V = \frac{1}{G_V} \times \left(1 + \frac{R_1}{R_2} \right)$$

(2)

Typical Application (continued)

Precision reference sources are available at 5 V or less. Use a ±5-V reference with a 2x gain configuration to get an output of ±10 V. The DAC output amplifier sets the gain at 2, assuming $G_V = 1$, as shown in Equation 3. R_1 and R_2 are 1-kΩ each. Equation 3 shows the calculation for the current gain when the switch is in the position 2.

$$A_V = \frac{1}{R_{SENSE} \times G_I} \times \left(1 + \frac{R_1}{R_2} \right) \tag{3}$$

In order to get ±20-mA output current range with $R_1 = R_2$, $R_{SENSE} \times G_I$ must be 500. Choose G_I as 50 so that R_{SENSE} can be 10-Ω. For a ±20-mA output current, the voltage drop across R_{SENSE} is ±200-mV. In case the design requires a lower voltage headroom, choose a higher value for G_I and a smaller resistance value for R_{SENSE} .

There is no equation to select C_1 and C_2 . The values of C_1 and C_2 depend on the stability criteria of the reference buffers when driving the reference inputs of DACx1001. The values are obtained through simulation. For the OPA828, use $C_1 = C_2 = 100$ pF. The 1-MΩ resistors in the circuit are used for making sure the amplifiers are not left in an open-loop state.

9.2.1.3 Application Curves

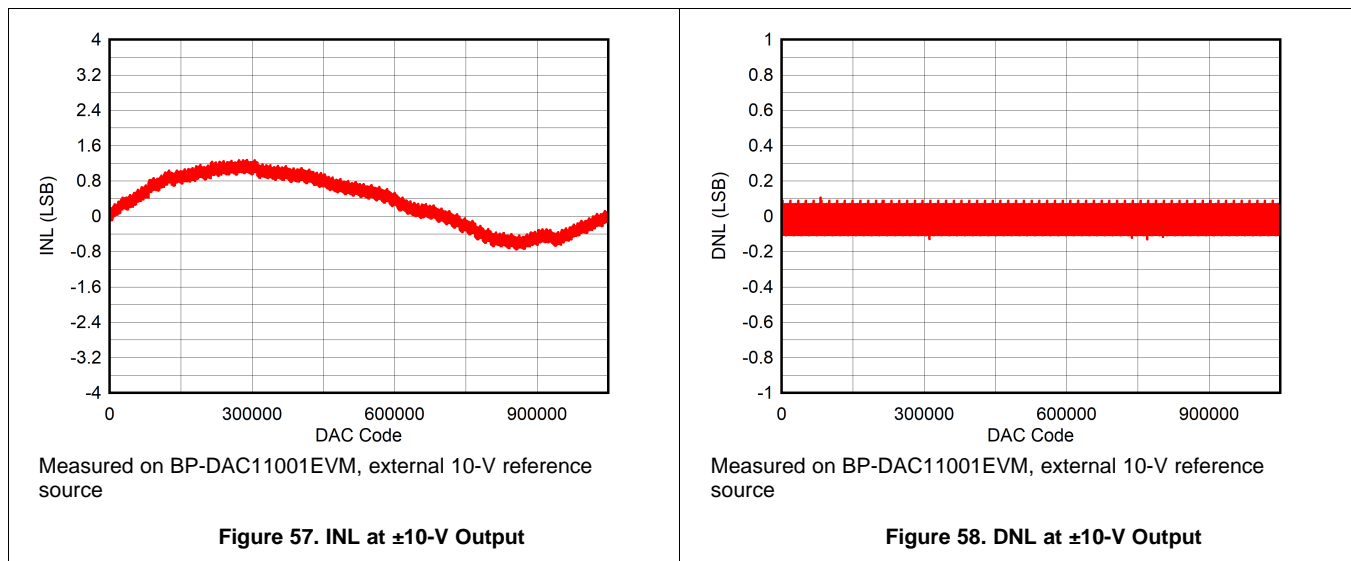

Typical Application (continued)

9.2.2 Battery Test Equipment (BTE)

Battery test equipment is used for lithium-ion battery formation, end-of-line testing, and diagnostics. For battery diagnostics, high-precision DACs, such as the DACx1001, are required to maintain a highly stable voltage over temperature and time.

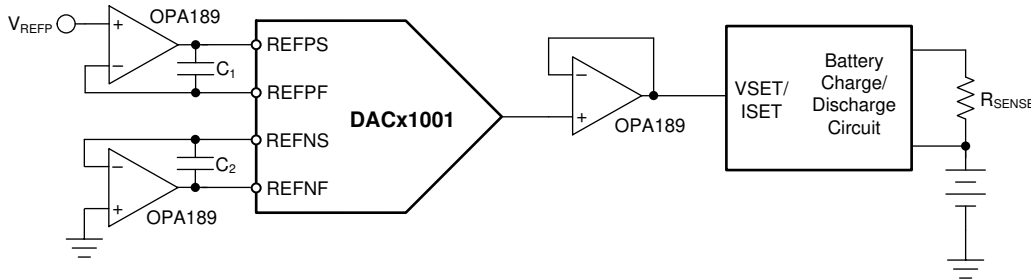

Figure 59. Battery Test Equipment

9.2.2.1 Design Requirements

- Output range: 0 V to 5 V
- System level temperature drift: ± 2 ppm/ $^{\circ}\text{C}$

9.2.2.2 Detailed Design Procedure

To get unipolar output from DACx1001, connect the negative reference input to ground as shown in Figure 59. The OPA189 is a zero-drift amplifier with ± 0.02 ppm/ $^{\circ}\text{C}$. The DACx1001 has a temperature drift of offset error of ± 0.04 ppm/ $^{\circ}\text{C}$. The temperature drifts of the DAC and amplifier might be neglected when compared to the temperature drift of the reference source. The best reference sources offer temperature drifts of the order of ± 2.5 ppm/ $^{\circ}\text{C}$ to ± 3 ppm/ $^{\circ}\text{C}$. A temperature calibration is needed for the voltage reference to achieve the goal of ± 2 ppm/ $^{\circ}\text{C}$.

9.2.2.3 Application Curves

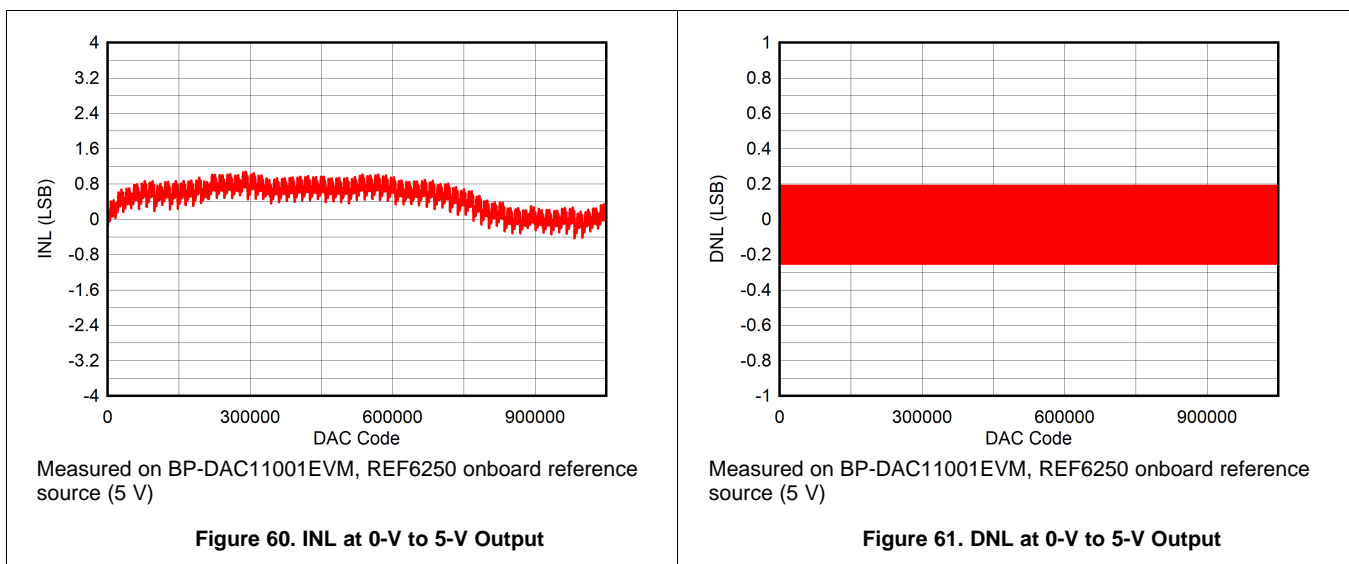

Typical Application (continued)

9.2.3 High-Precision Control Loop

High-precision control loops are used in precision motion-control applications, such as linear actuator control, servo motor control, galvanometer control, and more. The key requirements for such applications is resolution, monotonicity, settling time, and code-to-code glitch. Figure 62 provides a simplified circuit of a linear actuator control circuit, wherein the DACx1001 commands the set point and an analog loop controls the actuator.

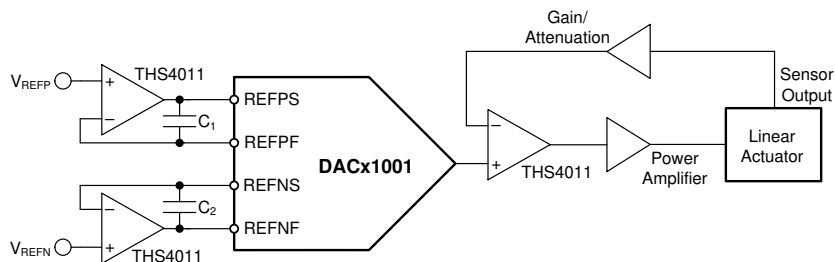

Figure 62. High-Precision Control Loop

9.2.3.1 Design Requirements

- DNL: ± 1 LSB max at 20-bits
- Settling time: $< 2 \mu\text{s}$
- Code-to-code glitch: $< 2 \text{ nV-s}$

9.2.3.2 Detailed Design Procedure

The DACx1001 provides 20-bit monotonic resolution at $< \pm 1$ LSB DNL. The device provides $< 2 \mu\text{s}$ settling time and $< 2 \text{ nV-s}$ code-to-code glitch for major carry transition. The reference and output buffer used for this design is the THS4011, a high-speed amplifier with a 90-ns settling time. For the best settling response, use C_1 and C_2 between 10 pF to 50 pF.

9.2.3.3 Application Curves

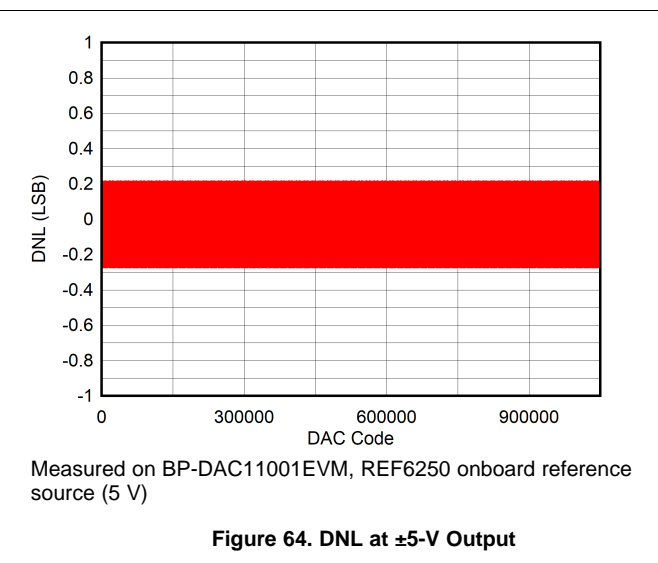
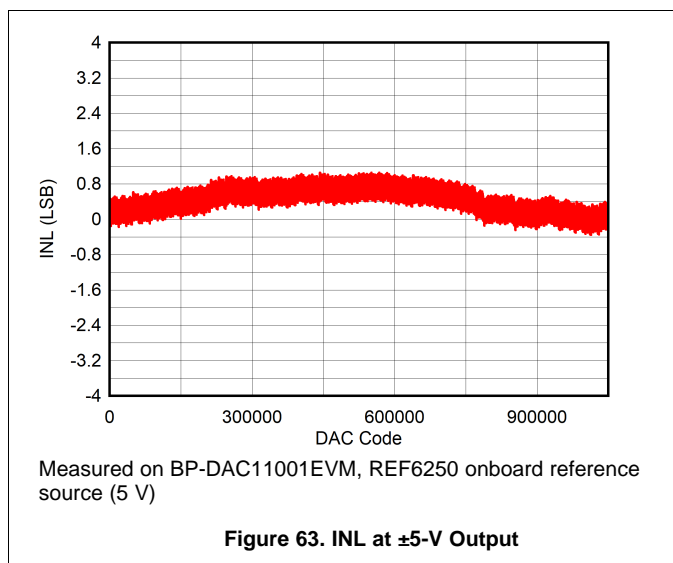

Typical Application (continued)

9.2.4 Arbitrary Waveform Generation (AWG)

Arbitrary waveform generation circuits are common in memory and semiconductor test equipment. These circuits are used to generate reference ac waveforms to test semiconductor devices. The key performance parameters of such circuits are THD, SNR, and the update rate. Figure 65 shows the basic building block example of an AWG circuit using the DACx1001.

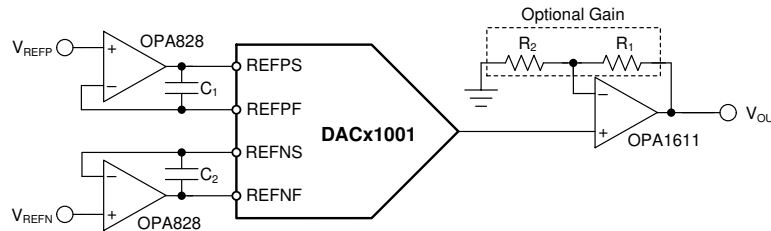

Figure 65. Arbitrary Waveform Generation

9.2.4.1 Design Requirements

- THD at 1 kHz: > -105 dB
- Update rate: 100 kHz

9.2.4.2 Detailed Design Procedure

The DACx1001 provides a THD of -105 dB at 1 kHz. The device provides update rates of up to 1 MHz, with marginal degradation in THD at higher frequencies. The OPA828 provides the best balance between the voltage and current noise densities, and is therefore an excellent choice to use as reference buffers. The OPA1611 is a low-distortion amplifier for high-THD applications.

9.2.4.3 Application Curves

The test conditions for the THD values in the graph of Figure 66 are a ±3-V reference input on the BP-DAC11001EVM, and an external 3x gain at the DAC output. The THD calculation considers 11 harmonics; the even harmonics are omitted. When two DACs are used in a differential output mode, the even harmonics are cancelled to a large extent. Figure 66 shows an ideal scenario, when the even harmonics are completely cancelled out.

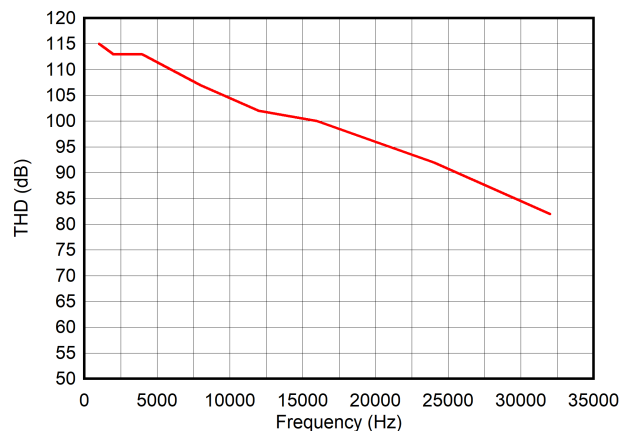

Figure 66. THD vs Frequency

9.3 System Examples

This section provides details on the digital interface and the embedded resistor configurations.

9.3.1 Interfacing to a Processor

The DACx1001 family of DACs works with a 4-wire SPI interface. The digital interface of the DACx1001 to a processor is shown in Figure 67. The DACx1001 has an $\overline{\text{LDAC}}$ input option for synchronous output update. In ac-signal generation applications, the jitter in the $\overline{\text{LDAC}}$ signal contributes to signal-to-noise ratio (SNR). Therefore, the $\overline{\text{LDAC}}$ signal must be generated from a low-jitter timer in the processor. The CLR and ALARM pins are static signals, and therefore can be connected to general-purpose input-output (GPIO) pins on the processor. All active-low signals (SYNC, $\overline{\text{LDAC}}$, CLR, and ALARM) must be pulled up to IOVDD using 10-k Ω resistors. ALARM is an output pin from the DAC, so the corresponding GPIO on the processor must be configured as an input. Either poll the GPIO, or configured the GPIO as an interrupt to detect any failure alarm from the DAC. When using a high SCLK frequency, use source termination resistors, as shown in Interfacing to a Processor. Typically, 33- Ω resistors work on printed circuit boards (PCBs) with a 50- Ω trace impedance.

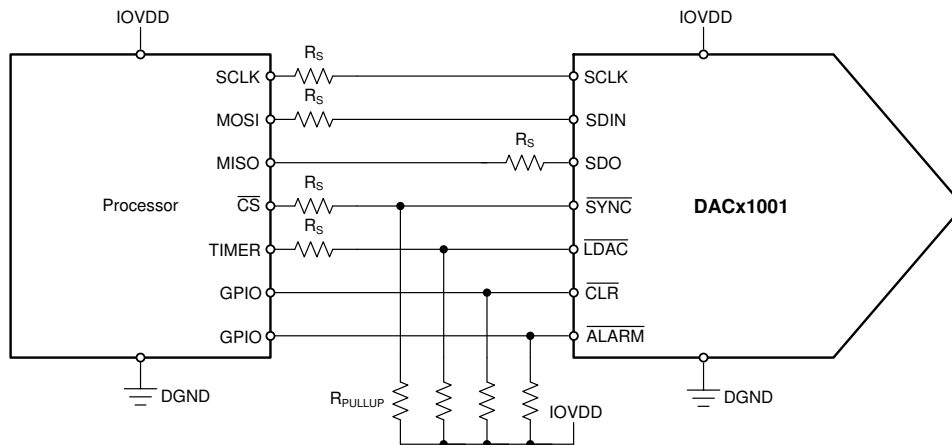

Figure 67. Interfacing to a Processor

9.3.2 Interfacing to a Low-Jitter $\overline{\text{LDAC}}$ Source

When the processor is not able to provide a low-jitter source for the $\overline{\text{LDAC}}$ signal, an external low-jitter LDAC source can be used, as shown in Figure 68. The processor can take the $\overline{\text{LDAC}}$ signal as an interrupt and trigger the SPI frame synchronously.

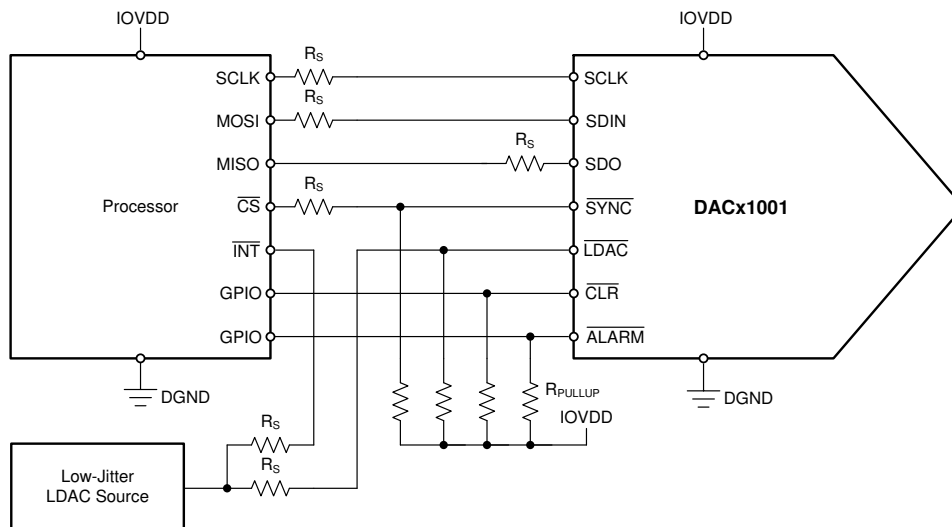

Figure 68. Interfacing to an External $\overline{\text{LDAC}}$ Source

System Examples (continued)

9.3.3 Embedded Resistor Configurations

The DACx1001 provides two embedded resistors with values is double the value of the output impedance of the R2R ladder. These resistors can be used in various configurations, as shown in the following subsections.

9.3.3.1 Minimizing Bias Current Mismatch

The bias current mismatch in the output amplifier can lead to offset error at the output. To minimize mismatch, the amplifier must have a matching resistor to that of the R2R output impedance on the feedback path. The feedback resistors are used in parallel for this purpose, as shown in [Figure 69](#). Some amplifiers may become unstable with a feedback resistor in the buffer configuration; therefore, a compensation capacitor (C_{COMP}) might be needed, as shown. The typical value of this capacitor is in the range of 22 pF to 100 pF, depending on the amplifier.

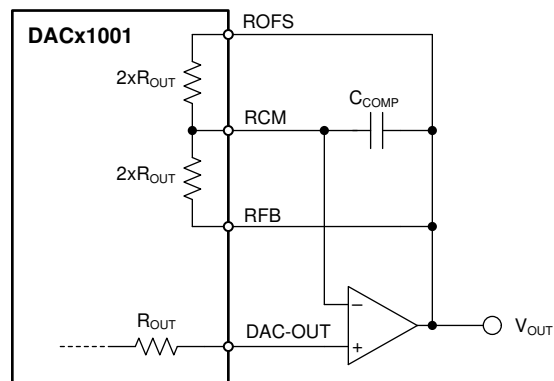

Figure 69. Minimizing Bias Current Mismatch

9.3.3.2 2x Gain configuration

The circuit of [Figure 69](#) can be configured for 2x gain by connecting one of the resistor ends to ground, as shown in [Figure 70](#).

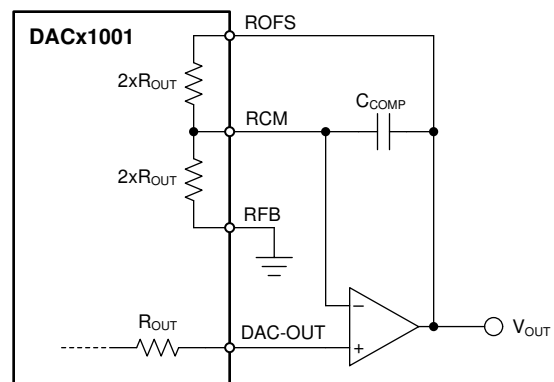

Figure 70. 2x Gain Configuration

System Examples (continued)

9.3.3.3 Generating Negative Reference

Generating a negative reference is a challenge because of the fact that the circuit needs an inverting amplifier involving resistors. The resistor mismatch and temperature drift can lead to inaccuracy. The embedded, matched resistors in DACx1001 can be used as shown in [Figure 71](#), the inverting amplifier configuration, to generate an accurate negative reference voltage.

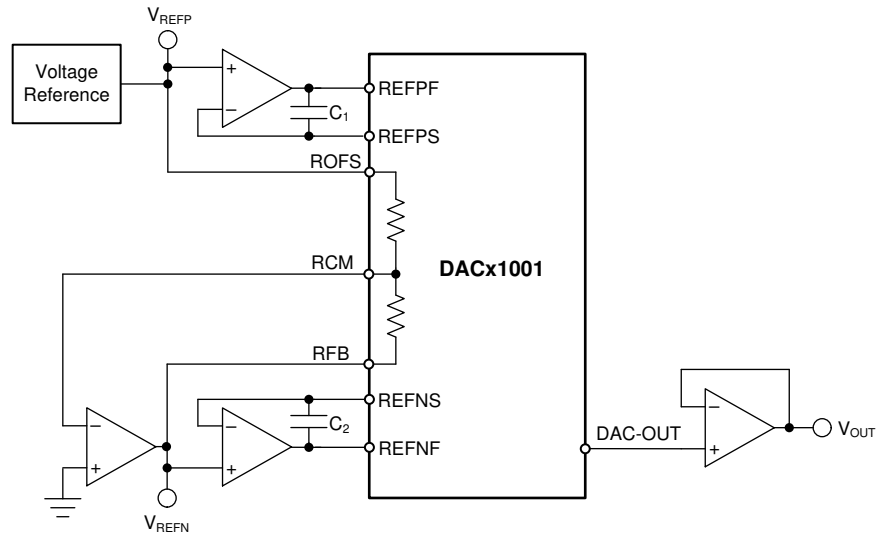

Figure 71. Generating Negative Reference

9.4 What to Do and What Not to Do

9.4.1 What to Do

- Follow recommended grounding, decoupling, and layout schemes for achieving best accuracy.
- Use a low-jitter LDAC source for best ac performance.
- Choose the appropriate amplifiers depending on the application requirements as explained in above sections.

9.4.2 What Not to Do

- Do not apply the reference before the DAC power supplies are powered on.
- Do not use the reference source directly with the DAC reference inputs without using buffers. or else the accuracy drastically degrades.

9.5 Initialization Set Up

The following text shows the pseudocode to get started with the DACx1001:

```
//SPI Settings
//Mode: Mode-1 (CPOL: 0, CPHA: 1)
//CS Type: Active Low, Per Packet
//Frame length: 32
//SYNTAX: WRITE <REGISTER (HEX ADDRESS)>, <HEX DATA>
//Select VREF, TnH mode (Good THD), LDAC mode and power-up the DAC
WRITE CONFIG (0x02), 0x004C80
//Write zero code to the DAC
WRITE DACDATA (0x01), 0x000000
//Write mid code to the DAC
WRITE DACDATA (0x01), 0x7FFFF0
//Write full code to the DAC
WRITE DACDATA (0x01), 0xFFFFF0
```

10 Power Supply Recommendations

To get the best performance out of the DACx1001, the power supply, grounding, and decoupling are very important. Use a PCB with a ground-plane reference, which helps in confining the digital return currents. A low mutual inductance path is created just beneath the high-frequency digital traces causing the return currents to follow the respective signal traces, thus minimizing crosstalk. On the other hand, dc signals spread over the ground plane without being confined below the signal trace. Therefore, in precision dc applications, limiting the common-impedance coupling is very difficult unless the ground planes are physically separated. Figure 72 shows a method to divide the grounds so that there is no common-mode current flow between the grounds, while maintaining the same dc potential across all grounds. This circuit assumes that the REFGND and LOAD-GND are provided from isolated power sources, therefore, there is no common-mode current flow through the reference or the load.

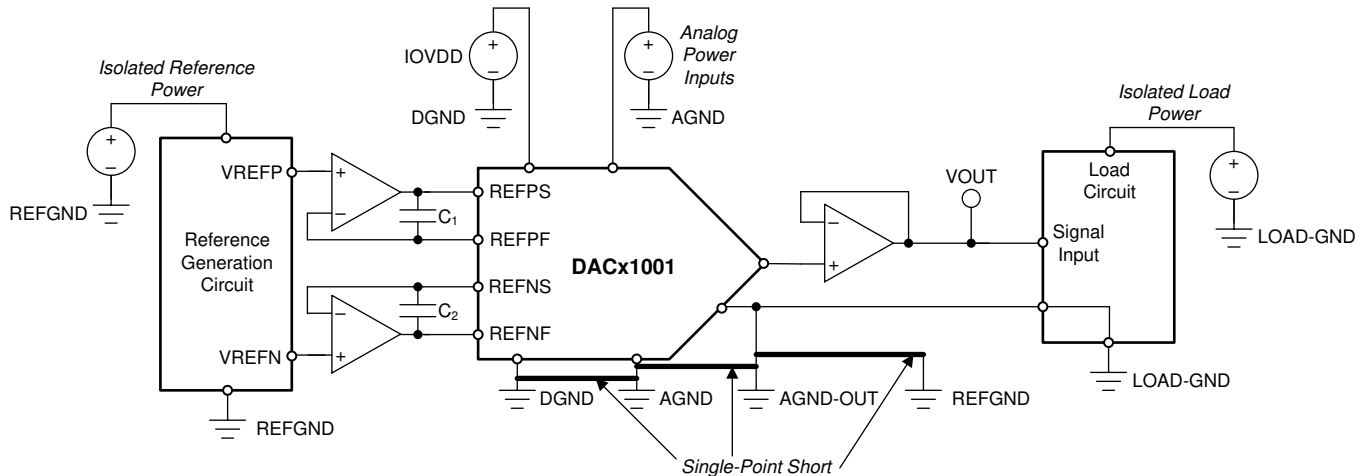

Figure 72. Power and Signal Grounding

When the load circuit is powered from a source referenced to AGND, and the LOAD-GND is shorted to AGND at the far end, the AGND-OUT must no longer be shorted to AGND locally near the DAC. The local shorting creates a ground loop, otherwise. The resulting connection that avoids the ground loop is shown in Figure 73.

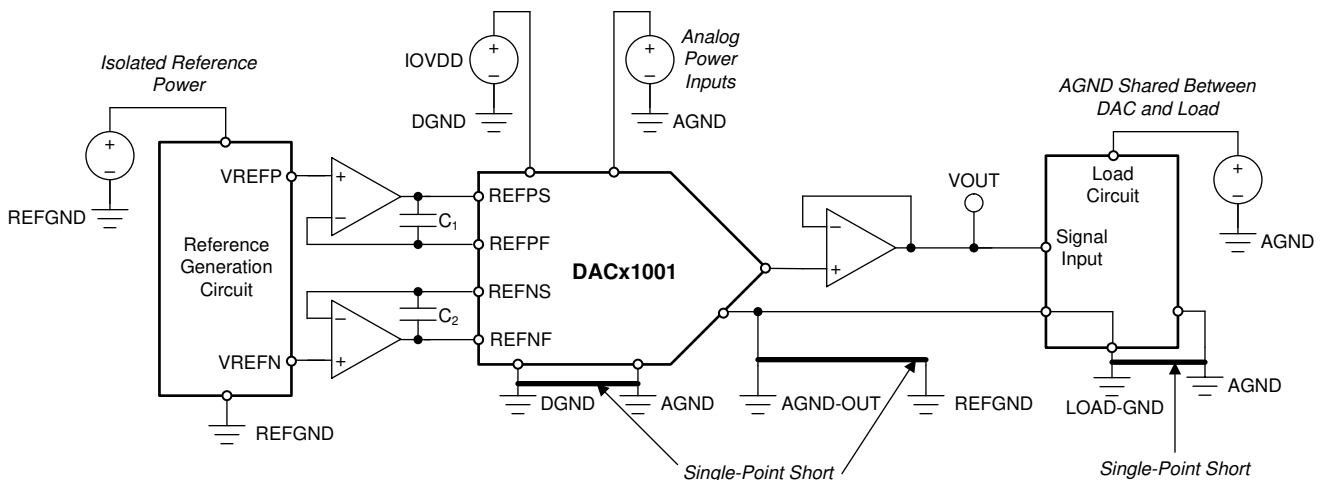

Figure 73. Grounding Scheme When AGND is Load Ground

When the reference source is powered from a power source with AGND as the ground, there is a possibility of common-impedance coupling causing a code-dependent shift in the reference voltage. To avoid undesired coupling, drive REFGND using a buffer that maintains the reference ground potential equals to that of AGND-OUT, as shown in Figure 74.

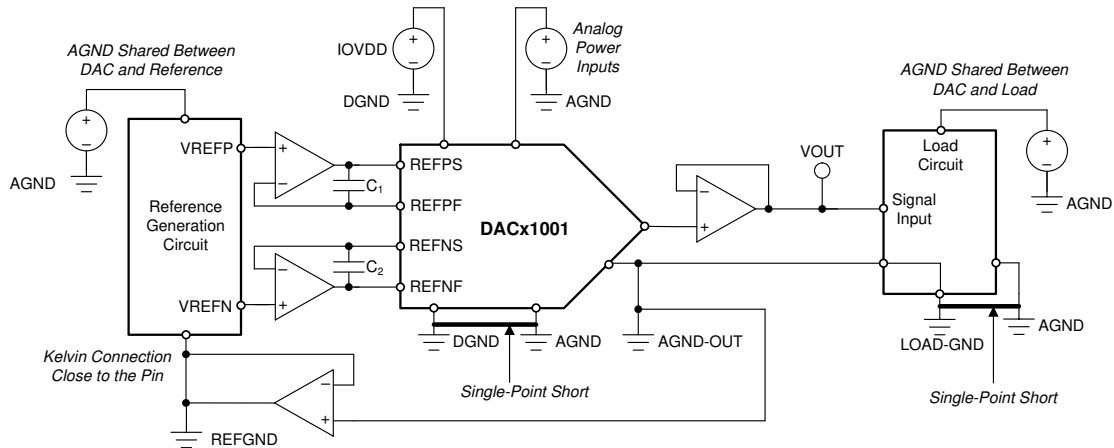

Figure 74. Connecting the Reference Ground

Channel-to-channel dc crosstalk is a major concern in multichannel applications, such as battery test equipment. While the DACx1001 is single-channel, the crosstalk problem can appear at a system level when using multiple DACx1001 devices. The problem becomes severe when the grounds of the loads are shorted together creating a possible ground loop. In such cases, avoid the local short between AGND and AGND-OUT. Use a single short between AGND and DGND for all the DACs. If the PCB layout allows for the digital signal and analog power supplies to be kept separate, DGND and AGND can be combined to a single ground plane. Figure 75 shows an example circuit for minimizing dc crosstalk across DAC channels in a system.

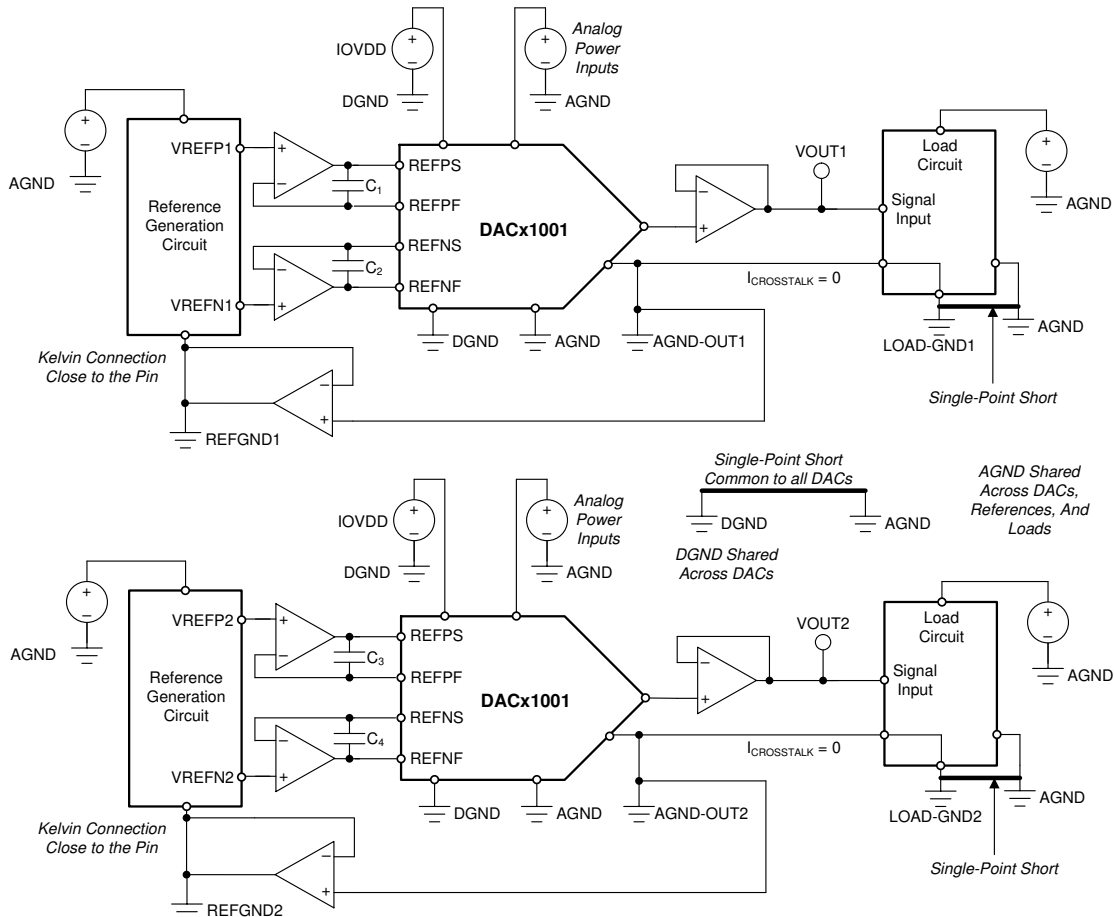

Figure 75. Minimizing Multichannel DC Crosstalk

Power-supply bypassing and decoupling is key to keeping power supply noise, switching transients, and common-mode currents away from the DAC output. There are three main objective of power-supply bypassing:

- *Filtering:* Filter out noise and ripple from power supplies
- *Bypassing:* Supply switching or load transient currents locally by avoiding trace inductances
- *Decoupling:* Stop local transient currents from impacting other circuits

To achieve these objectives, use the following 3-element scheme. Place a decoupling capacitor close to every power supply pin to provide the local current path for load and circuit switching transients. This capacitor must be referenced to the respective load ground for best load transient suppression. Use a 0.1- μF to 1- μF , X7R, multilayer ceramic capacitor (MLCC) for this purpose. For analog power supplies, a 10- Ω series resistor provides the best decoupling. For filtering the power-supply noise and ripple, 10- μF capacitors work best when placed at the power entry point of the board. An example decoupling scheme is shown in [Figure 76](#).

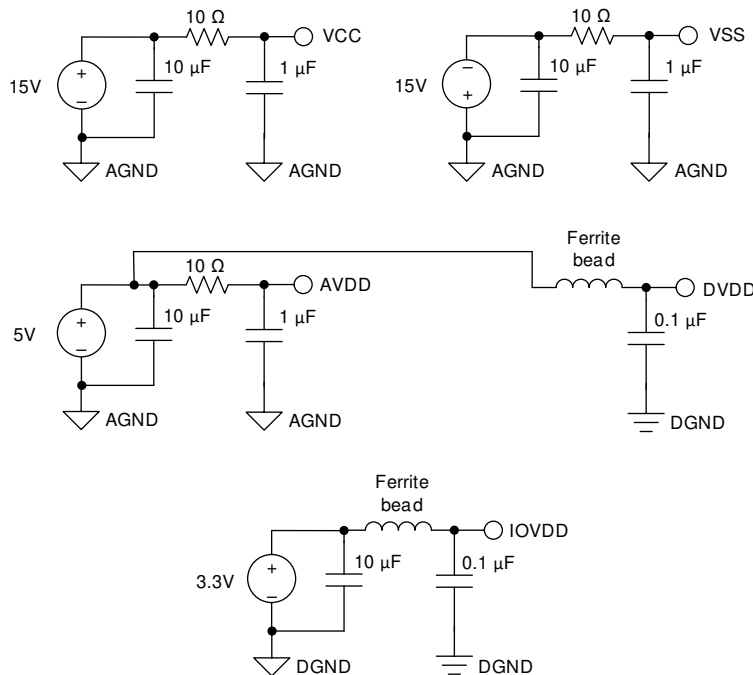

Figure 76. Power-Supply Decoupling

10.1 Power-Supply Sequencing

The DACx1001 do not require any power-supply sequence. However, the power supplies to the AVDD pin must be capable of providing 30-mA of current if V_{SS} ramps before AV_{DD} . This current is derived from the AVDD pin, and flows out of the VSS pin. This condition is transient, and the device stops consuming this current when the power supplies are ramped up. To avoid this condition, make sure to ramp AV_{DD} before V_{SS} .

11 Layout

11.1 Layout Guidelines

PCB layout plays a significant role for achieving desired ac and dc performance from the DACx1001. The DACx1001 has a pinout that supports easy splitting of the noisy and quiet grounds. The digital signals are available on two adjacent sides of the device; whereas, the power and analog signals are available separate sides. [Figure 77](#) shows an example layout, where the different ground planes have been clearly demarcated. The figure also shows the best positions for the single-point shorts between the ground planes. For best power-supply bypassing, place the bypass capacitors close to the respective power pins as shown. Provide unbroken ground reference planes for the digital signal traces, especially for the SPI and LDAC signals.

11.2 Layout Example

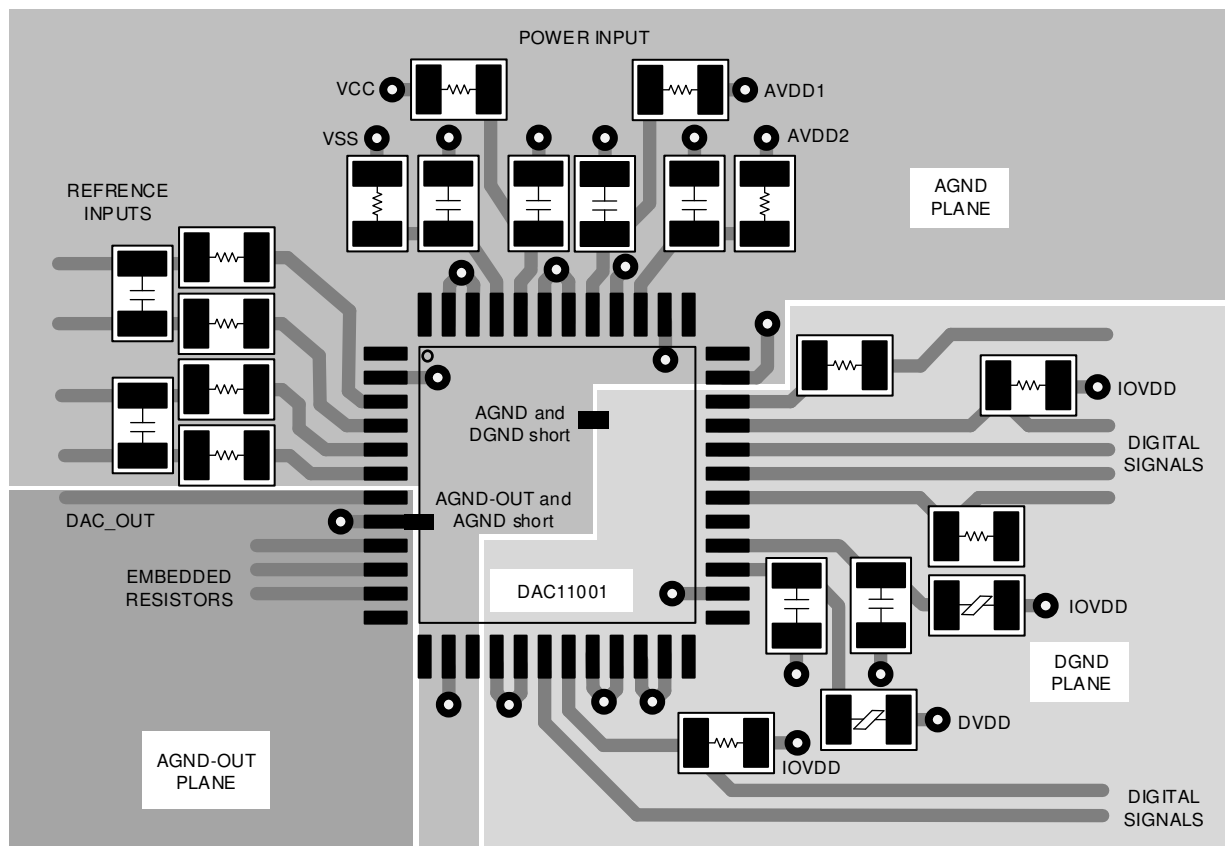

Figure 77. Layout Example

12 Device and Documentation Support

12.1 Device Support

12.1.1 Development Support

[BP-DAC11001 Evaluation Module](#)

12.2 Documentation Support

12.2.1 Related Documentation

For related documentation see the following:

- Texas Instruments, [BP-DAC11001EVM user's guide](#)
- Texas Instruments, [Impact of Code-to-Code Glitch in Precision Applications application brief](#)

12.3 Related Links

[Table 12](#) lists quick access links. Categories include technical documents, support and community resources, tools and software, and quick access to order now.

Table 12. Related Links

PARTS	PRODUCT FOLDER	ORDER NOW	TECHNICAL DOCUMENTS	TOOLS & SOFTWARE	SUPPORT & COMMUNITY
DAC11001A	Click here	Click here	Click here	Click here	Click here
DAC91001	Click here	Click here	Click here	Click here	Click here
DAC81001	Click here	Click here	Click here	Click here	Click here

12.4 Receiving Notification of Documentation Updates

To receive notification of documentation updates, navigate to the device product folder on ti.com. In the upper right corner, click on *Alert me* to register and receive a weekly digest of any product information that has changed. For change details, review the revision history included in any revised document.

12.5 Support Resources

[TI E2E™ support forums](#) are an engineer's go-to source for fast, verified answers and design help — straight from the experts. Search existing answers or ask your own question to get the quick design help you need.

Linked content is provided "AS IS" by the respective contributors. They do not constitute TI specifications and do not necessarily reflect TI's views; see TI's [Terms of Use](#).

12.6 Trademarks

E2E is a trademark of Texas Instruments.
All other trademarks are the property of their respective owners.

12.7 Electrostatic Discharge Caution



This integrated circuit can be damaged by ESD. Texas Instruments recommends that all integrated circuits be handled with appropriate precautions. Failure to observe proper handling and installation procedures can cause damage.

ESD damage can range from subtle performance degradation to complete device failure. Precision integrated circuits may be more susceptible to damage because very small parametric changes could cause the device not to meet its published specifications.

12.8 Glossary

[SLYZ022](#) — *TI Glossary*.

This glossary lists and explains terms, acronyms, and definitions.

13 Mechanical, Packaging, and Orderable Information

The following pages include mechanical, packaging, and orderable information. This information is the most current data available for the designated devices. This data is subject to change without notice and revision of this document. For browser-based versions of this data sheet, refer to the left-hand navigation.

PACKAGING INFORMATION

Orderable Device	Status (1)	Package Type	Package Drawing	Pins	Package Qty	Eco Plan (2)	Lead finish/ Ball material (6)	MSL Peak Temp (3)	Op Temp (°C)	Device Marking (4/5)	Samples
DAC11001APFBR	ACTIVE	TQFP	PFB	48	1000	Green (RoHS & no Sb/Br)	NIPDAU-DCC	Level-3-260C-168 HR	-40 to 125	DAC11001A	Samples
DAC11001APFBT	ACTIVE	TQFP	PFB	48	250	Green (RoHS & no Sb/Br)	NIPDAU-DCC	Level-3-260C-168 HR	-40 to 125	DAC11001A	Samples
DAC81001PFBR	ACTIVE	TQFP	PFB	48	1000	Green (RoHS & no Sb/Br)	NIPDAU-DCC	Level-3-260C-168 HR	-40 to 125	DAC81001	Samples
DAC81001PFBT	ACTIVE	TQFP	PFB	48	250	Green (RoHS & no Sb/Br)	NIPDAU-DCC	Level-3-260C-168 HR	-40 to 125	DAC81001	Samples
DAC91001PFBR	ACTIVE	TQFP	PFB	48	1000	Green (RoHS & no Sb/Br)	NIPDAU-DCC	Level-3-260C-168 HR	-40 to 125	DAC91001	Samples
DAC91001PFBT	ACTIVE	TQFP	PFB	48	250	Green (RoHS & no Sb/Br)	NIPDAU-DCC	Level-3-260C-168 HR	-40 to 125	DAC91001	Samples
PDAC91001PFBT	ACTIVE	TQFP	PFB	48	250	TBD	Call TI	Call TI	-40 to 125		Samples

(1) The marketing status values are defined as follows:

ACTIVE: Product device recommended for new designs.

LIFEBUY: TI has announced that the device will be discontinued, and a lifetime-buy period is in effect.

NRND: Not recommended for new designs. Device is in production to support existing customers, but TI does not recommend using this part in a new design.

PREVIEW: Device has been announced but is not in production. Samples may or may not be available.

OBSOLETE: TI has discontinued the production of the device.

(2) **RoHS:** TI defines "RoHS" to mean semiconductor products that are compliant with the current EU RoHS requirements for all 10 RoHS substances, including the requirement that RoHS substance do not exceed 0.1% by weight in homogeneous materials. Where designed to be soldered at high temperatures, "RoHS" products are suitable for use in specified lead-free processes. TI may reference these types of products as "Pb-Free".

RoHS Exempt: TI defines "RoHS Exempt" to mean products that contain lead but are compliant with EU RoHS pursuant to a specific EU RoHS exemption.

Green: TI defines "Green" to mean the content of Chlorine (Cl) and Bromine (Br) based flame retardants meet JS709B low halogen requirements of <=1000ppm threshold. Antimony trioxide based flame retardants must also meet the <=1000ppm threshold requirement.

(3) MSL, Peak Temp. - The Moisture Sensitivity Level rating according to the JEDEC industry standard classifications, and peak solder temperature.

(4) There may be additional marking, which relates to the logo, the lot trace code information, or the environmental category on the device.

(5) Multiple Device Markings will be inside parentheses. Only one Device Marking contained in parentheses and separated by a "~" will appear on a device. If a line is indented then it is a continuation of the previous line and the two combined represent the entire Device Marking for that device.

⁽⁶⁾ Lead finish/Ball material - Orderable Devices may have multiple material finish options. Finish options are separated by a vertical ruled line. Lead finish/Ball material values may wrap to two lines if the finish value exceeds the maximum column width.

Important Information and Disclaimer: The information provided on this page represents TI's knowledge and belief as of the date that it is provided. TI bases its knowledge and belief on information provided by third parties, and makes no representation or warranty as to the accuracy of such information. Efforts are underway to better integrate information from third parties. TI has taken and continues to take reasonable steps to provide representative and accurate information but may not have conducted destructive testing or chemical analysis on incoming materials and chemicals. TI and TI suppliers consider certain information to be proprietary, and thus CAS numbers and other limited information may not be available for release.

In no event shall TI's liability arising out of such information exceed the total purchase price of the TI part(s) at issue in this document sold by TI to Customer on an annual basis.

TAPE AND REEL INFORMATION

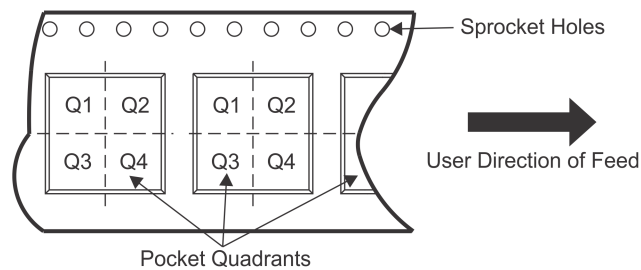
QUADRANT ASSIGNMENTS FOR PIN 1 ORIENTATION IN TAPE

*All dimensions are nominal

Device	Package Type	Package Drawing	Pins	SPQ	Reel Diameter (mm)	Reel Width W1 (mm)	A0 (mm)	B0 (mm)	K0 (mm)	P1 (mm)	W (mm)	Pin1 Quadrant
DAC11001APFBR	TQFP	PFB	48	1000	330.0	16.4	9.6	9.6	1.5	12.0	16.0	Q2
DAC11001APFBT	TQFP	PFB	48	250	180.0	16.4	9.6	9.6	1.5	12.0	16.0	Q2
DAC81001PFBR	TQFP	PFB	48	1000	330.0	16.4	9.6	9.6	1.5	12.0	16.0	Q2
DAC81001PFBT	TQFP	PFB	48	250	180.0	16.4	9.6	9.6	1.5	12.0	16.0	Q2
DAC91001PFBR	TQFP	PFB	48	1000	330.0	16.4	9.6	9.6	1.5	12.0	16.0	Q2
DAC91001PFBT	TQFP	PFB	48	250	180.0	16.4	9.6	9.6	1.5	12.0	16.0	Q2

TAPE AND REEL BOX DIMENSIONS



*All dimensions are nominal

Device	Package Type	Package Drawing	Pins	SPQ	Length (mm)	Width (mm)	Height (mm)
DAC11001APFBR	TQFP	PFB	48	1000	350.0	350.0	43.0
DAC11001APFBT	TQFP	PFB	48	250	213.0	191.0	55.0
DAC81001PFBR	TQFP	PFB	48	1000	350.0	350.0	43.0
DAC81001PFBT	TQFP	PFB	48	250	367.0	367.0	38.0
DAC91001PFBR	TQFP	PFB	48	1000	350.0	350.0	43.0
DAC91001PFBT	TQFP	PFB	48	250	213.0	191.0	55.0

PFB (S-PQFP-G48)

PLASTIC QUAD FLATPACK

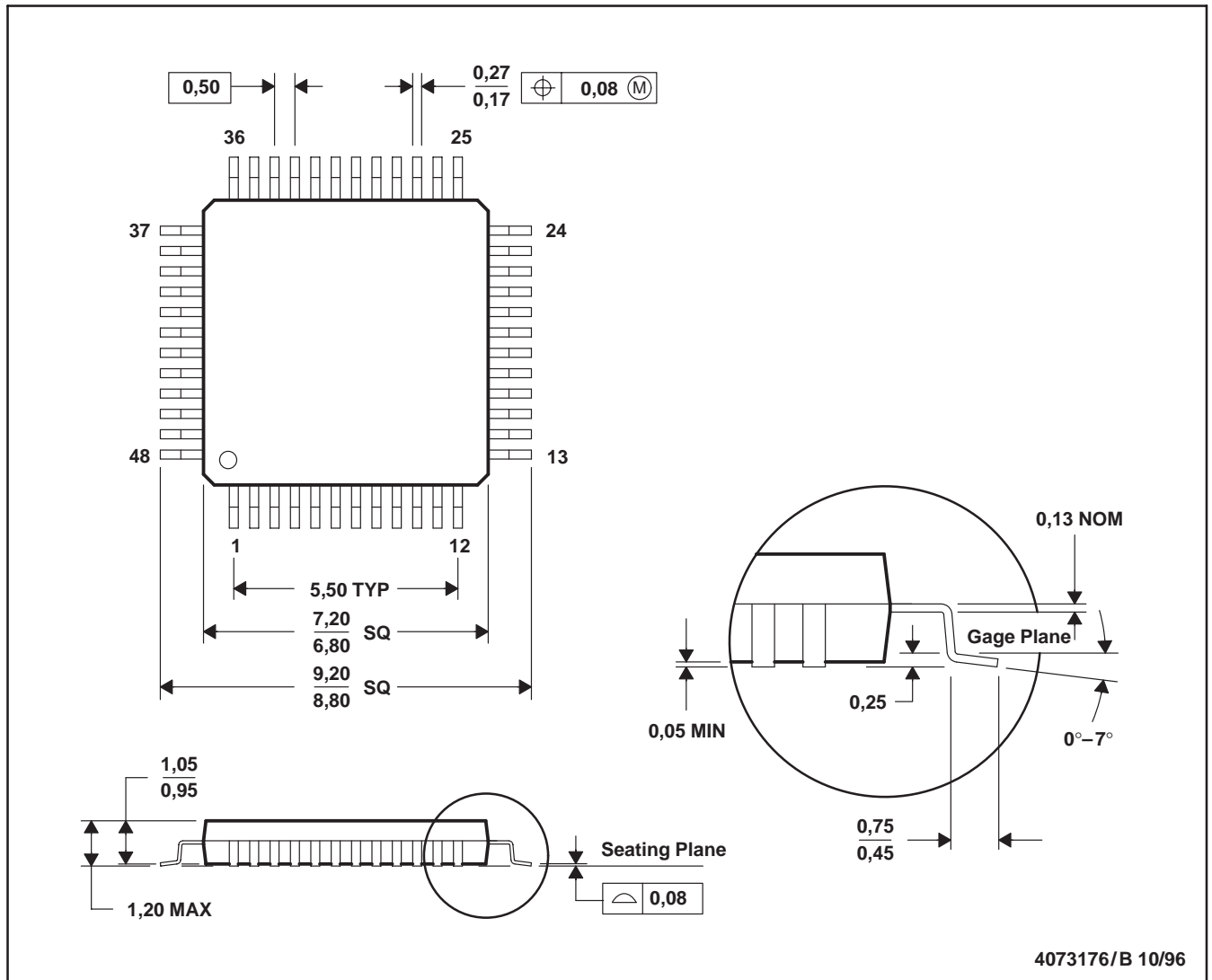

- NOTES: A. All linear dimensions are in millimeters.
 B. This drawing is subject to change without notice.
 C. Falls within JEDEC MS-026

IMPORTANT NOTICE AND DISCLAIMER

TI PROVIDES TECHNICAL AND RELIABILITY DATA (INCLUDING DATASHEETS), DESIGN RESOURCES (INCLUDING REFERENCE DESIGNS), APPLICATION OR OTHER DESIGN ADVICE, WEB TOOLS, SAFETY INFORMATION, AND OTHER RESOURCES "AS IS" AND WITH ALL FAULTS, AND DISCLAIMS ALL WARRANTIES, EXPRESS AND IMPLIED, INCLUDING WITHOUT LIMITATION ANY IMPLIED WARRANTIES OF MERCHANTABILITY, FITNESS FOR A PARTICULAR PURPOSE OR NON-INFRINGEMENT OF THIRD PARTY INTELLECTUAL PROPERTY RIGHTS.

These resources are intended for skilled developers designing with TI products. You are solely responsible for (1) selecting the appropriate TI products for your application, (2) designing, validating and testing your application, and (3) ensuring your application meets applicable standards, and any other safety, security, or other requirements. These resources are subject to change without notice. TI grants you permission to use these resources only for development of an application that uses the TI products described in the resource. Other reproduction and display of these resources is prohibited. No license is granted to any other TI intellectual property right or to any third party intellectual property right. TI disclaims responsibility for, and you will fully indemnify TI and its representatives against, any claims, damages, costs, losses, and liabilities arising out of your use of these resources.

TI's products are provided subject to TI's Terms of Sale (www.ti.com/legal/termsofsale.html) or other applicable terms available either on ti.com or provided in conjunction with such TI products. TI's provision of these resources does not expand or otherwise alter TI's applicable warranties or warranty disclaimers for TI products.

Mailing Address: Texas Instruments, Post Office Box 655303, Dallas, Texas 75265
Copyright © 2020, Texas Instruments Incorporated