



Ultra-Low-Power, Octal, 12-Bit, 50Msps, 1.8V ADC with Serial LVDS Outputs

MAX19527

General Description

The MAX19527 is an octal, 12-bit analog-to-digital converter (ADC), optimized for the low-power and high-dynamic performance requirements of medical imaging instrumentation and digital communications applications. The device operates from a single 1.8V supply and consumes 440mW (55mW per channel), while providing a 69dBFS signal-to-noise ratio (SNR) at a 5.3MHz input frequency. In addition to low operating power, the device features programmable power management for idle states and reduced-channel operation.

An internal 1.25V precision bandgap reference sets the full-scale range of the ADC to 1.5V_{P-P}. A flexible reference structure allows the use of an external reference for applications requiring greater gain accuracy or a different input voltage range. A programmable common-mode voltage reference output is provided to enable DC-coupled input applications.

Various adjustments and feature selections are available through programmable registers that are accessed through the 3-wire serial peripheral interface (SPI™).

A flexible clock input circuit allows for a single-ended, logic-level clock or a differential clock signal. An on-chip PLL generates the multiplied (6x) clock required for the serial LVDS digital outputs. The serial LVDS output provides programmable test patterns for data timing alignment and output drivers with programmable current drive and programmable internal termination.

The device is available in a small, 10mm x 10mm x 1.2mm, 144-lead thin chip ball grid array (CTBGA) package and is specified for the extended industrial (-40°C to +85°C) temperature range.

Applications

Ultrasound and Medical Imaging
Instrumentation
Multichannel Communications
ZIF GSM and TD-SCDMA Transceivers

Features

- ◆ Ultra-Low-Power Operation
55mW per Channel at 50Msps
- ◆ Single 1.8V Power Supply
- ◆ Excellent Dynamic Performance
69dBFS SNR at 5.3MHz
140dBc/Hz Near-Carrier SNR at 1kHz Offset
from a 5.3MHz Tone
84dBc SFDR at 5.3MHz
90dB Channel Isolation at 5.3MHz
- ◆ User-Programmable Adjustment and Feature Selection through an SPI Interface
- ◆ Serial LVDS Outputs with Programmable Current Drive and Internal Termination
- ◆ Programmable Power Management
- ◆ Internal or External Reference Operation
- ◆ Single-Ended or Differential Clock Input
- ◆ Programmable Output Data Format
- ◆ Built-In Output Data Test Patterns
- ◆ Small, 10mm x 10mm, 144-Lead CTBGA Package
- ◆ Evaluation Kit Available (Order MAX19527EVKIT+)

Ordering Information

PART	TEMP RANGE	PIN-PACKAGE
MAX19527EXE+	-40°C to +85°C	144 CTBGA

+Denotes a lead(Pb)-free/RoHS-compliant package.

SPI is a trademark of Motorola, Inc.



Ultra-Low-Power, Octal, 12-Bit, 50Mps, 1.8V ADC with Serial LVDS Outputs

ABSOLUTE MAXIMUM RATINGS

AVDD, OVDD to GND	-0.3V to +2.1V
OGND to GND.....	-0.3V to +0.3V
IN ₊ , IN ₋ , CMOUT, REFIO, REFH, REFL, CLKIN+, CLKIN- to GND	-0.3V to the lower of (VAVDD + 0.3V) and +2.1V
OUT ₊ , OUT ₋ , FRAME+, FRAME-, CLKOUT+, CLKOUT-, SHDN, CS, SCLK, SDIO to GND.....	-0.3V to the lower of (VOVDD + 0.3V) and +2.1V

Continuous Power Dissipation (T _A = +70°C)	
144-Lead CTBGA (derate 37mW/°C above +70°C)	
Multilayer Board	2963mW
Operating Temperature Range	-40°C to +85°C
Junction Temperature	+150°C
Storage Temperature Range	-65°C to +150°C
Lead Temperature (soldering, 10s)	+300°C
Soldering Temperature (reflow)	+260°C

Stresses beyond those listed under "Absolute Maximum Ratings" may cause permanent damage to the device. These are stress ratings only, and functional operation of the device at these or any other conditions beyond those indicated in the operational sections of the specifications is not implied. Exposure to absolute maximum rating conditions for extended periods may affect device reliability.

ELECTRICAL CHARACTERISTICS

(VAVDD = 1.8V, VOVDD = 1.8V, internal reference, A_{IN} = -0.5dBFS, differential clock, V_{CLKD} = 1.5V_{P-P}, f_{CLK} = 50MHz, programmable registers at default settings (Table 1), T_A = -40°C to +85°C, typical values are at T_A = +25°C, unless otherwise noted.) (Note 1)

PARAMETER	SYMBOL	CONDITIONS	MIN	TYP	MAX	UNITS
DC ACCURACY						
Resolution				12		Bits
Integral Nonlinearity	INL	f _{IN} = 5.3MHz		±0.5	±1.7	LSB
Differential Nonlinearity	DNL	f _{IN} = 5.3MHz, no missing codes		±0.3	±1.0	LSB
Offset Error	OE	Internal reference		±0.07	±0.7	%FS
Gain Error	GE	External reference = 1.25V		±0.2	±3.0	%FS
ANALOG INPUTS (IN₊, IN₋) (Figure 2)						
Input Differential Range	V _{DIFF}	IN ₊ - IN ₋		1.5		V _{P-P}
Common-Mode Input Voltage Range	V _{CM}	±50mV tolerance		1050		mV
Input Resistance	R _{IN}	Fixed resistance to GND		> 100		kΩ
		Differential input resistance, common mode connected to inputs		4		
Input Current	I _{IN}	Switched capacitance input current, each input, V _{CM} = 1.050V		36		μA
Input Capacitance	C _{INS}	Fixed capacitance to GND, each input		1		pF
	C _{IND}	Fixed differential capacitance		0.2		
	C _{SAMPLE}	Switched capacitance, each input		1.5		
CONVERSION RATE						
Maximum Clock Frequency	f _{CLK}		50			MHz
Minimum Clock Frequency	f _{CLK}				25	MHz
Data Latency		Figure 5		8.5		Clock Cycles

Ultra-Low-Power, Octal, 12-Bit, 50MSPS, 1.8V ADC with Serial LVDS Outputs

MAX19527

ELECTRICAL CHARACTERISTICS (continued)

(VAVDD = 1.8V, VOVD = 1.8V, internal reference, AIN = -0.5dBFS, differential clock, VCLKD = 1.5Vp-p, fCLK = 50MHz, programmable registers at default settings (Table 1), TA = -40°C to +85°C, typical values are at TA = +25°C, unless otherwise noted.) (Note 1)

PARAMETER	SYMBOL	CONDITIONS	MIN	TYP	MAX	UNITS
DYNAMIC PERFORMANCE						
Small-Signal Noise Floor	SSNF	Analog input < -35dBFS, fIN = 5.3MHz		-69.5		dBFS
Near-Carrier Signal-to-Noise Ratio	NCSNR	1kHz offset from 5.3MHz full-scale tone, CREFIO = CREFH/REFL = 0.1μF (Figure 3)		140		dBc/Hz
		8-channel coherent sum		147		
Signal-to-Noise Ratio	SNR	fIN = 5.3MHz at -0.5dBFS	67.0	68.5		dB
		fIN = 19.3MHz at -0.5dBFS		68.5		
Signal-to-Noise and Distortion Ratio	SINAD	fIN = 5.3MHz at -0.5dBFS	66.6	68.2		dB
		fIN = 19.3MHz at -0.5dBFS		68.2		
Spurious-Free Dynamic Range	SFDR	fIN = 5.3MHz at -0.5dBFS	70.0	84		dBc
		fIN = 19.3MHz at -0.5dBFS		84		
Total Harmonic Distortion	THD	fIN = 5.3MHz at -0.5dBFS		-81	-72	dBc
		fIN = 19.3MHz at -0.5dBFS		-81		
Intermodulation Distortion	IMD	fIN1 = 5.15MHz at -6.5dBFS, fIN2 = 5.45MHz at -6.5dBFS		-83		dB
Full-Power Bandwidth	FPBW	RSOURCE = 50Ω differential		> 500		MHz
Overdrive Recovery Time		6dB beyond full scale (recover accuracy to < 1% of full scale)		< 1		Clock Cycles
INTERCHANNEL CHARACTERISTICS						
Crosstalk		fIN = 5.3MHz at -0.5dBFS		-90		dB
Gain Matching		fIN = 5.3MHz		±0.1		dB
Phase Matching		fIN = 5.3MHz		±0.25		Degrees
ANALOG OUTPUT (CMOUT)						
CMOUT Output Voltage	VCMOUT	Default programming state	1.05	1.10	1.15	V
INTERNAL REFERENCE						
REFIO Output Voltage	VREFIO	Bypass only, no DC load	1.22	1.25	1.28	V
REFIO Temperature Coefficient	TCREF			< ±60		ppm/°C
REFH Voltage	VREFH	Bypass only, no DC load		1.61		V
REFL Voltage	VREFL	Bypass only, no DC load		0.86		V
EXTERNAL REFERENCE						
REFIO Input Voltage Range	VREFIN	+5%/-15% tolerance		1.25		V
REFIO Input Resistance	RREFIN			10 ± 20%		kΩ

Ultra-Low-Power, Octal, 12-Bit, 50MSPs, 1.8V ADC with Serial LVDS Outputs

ELECTRICAL CHARACTERISTICS (continued)

($V_{AVDD} = 1.8V$, $V_{OVDD} = 1.8V$, internal reference, $A_{IN} = -0.5dBFS$, differential clock, $V_{CLKD} = 1.5V_{P-P}$, $f_{CLK} = 50MHz$, programmable registers at default settings (Table 1), $T_A = -40^{\circ}C$ to $+85^{\circ}C$, typical values are at $T_A = +25^{\circ}C$, unless otherwise noted.) (Note 1)

PARAMETER	SYMBOL	CONDITIONS	MIN	TYP	MAX	UNITS
CLOCK INPUTS (CLKIN+, CLKIN-)—DIFFERENTIAL MODE (Figure 4)						
Differential Clock Input Voltage	VCLKD			0.4 to 2.0		V _{P-P}
Common-Mode Voltage	VCLKCM	Self-biased		1.2		V
		DC-coupled clock signal		1.0 to 1.4		
Input Resistance	RCLK	Differential, default setting		10		k Ω
		Differential, programmable internal termination selected		0.1		
		Common mode to GND		9		
Input Capacitance	CCLK	Capacitance to GND, each input		3		pF
CLOCK INPUTS (CLKIN+, CLKIN-)—SINGLE-ENDED MODE (CLKIN- < 0.1V) (Figure 4)						
Single-Ended Mode Selection Threshold (CLKIN-)	V _{IL}				0.1	V
Single-Ended Clock Input High Threshold (CLKIN+)	V _{IH}		1.5			V
Single-Ended Clock Input Low Threshold (CLKIN+)	V _{IL}				0.3	V
Input Leakage (CLKIN+)	I _{IH}	V _{IH} = 1.8V			+5	μA
	I _{IL}	V _{IH} = 0V	-5			
Input Leakage (CLKIN-)	I _{IL}	V _{IH} = 0V	-150		-50	μA
Input Capacitance (CLKIN+)				3		pF
DIGITAL INPUTS (SHDN, SCLK, SDIN, CS)						
Input High Threshold	V _{IH}		1.5			V
Input Low Threshold	V _{IL}				0.3	V
Input Leakage	I _{IH}	V _{IH} = 1.8V			+5	μA
	I _{IL}	V _{IL} = 0V	-5			
Input Capacitance	C _{DIN}			3		pF
DIGITAL OUTPUTS (SDIO)						
Output Voltage Low	V _{OL}	I _{SINK} = 200 μA			0.2	V
Output Voltage High	V _{OH}	I _{SOURCE} = 200 μA	O _{VDD} - 0.2			V
LVDS DIGITAL OUTPUTS (OUT_+/OUT_-, CLKOUT+/CLKOUT-, FRAME+/FRAME-)						
Differential Output Voltage	V _{ODI}	External R _{LOAD} = 100 Ω	250		450	mV
Output Offset Voltage	V _{OS}	External R _{LOAD} = 100 Ω	1.125		1.375	V
POWER-MANAGEMENT CHARACTERISTICS (Figure 3)						
Wake-Up Time from Sleep Mode	t _{SWAKE}	Internal reference, C _{REFIO} = 0.1 μF , C _{REFH/REFL} = 0.1 μF ; $\pm 1\%$ gain error, with respect to steady-state gain		10		ms
Wake-Up Time from Nap Mode	t _{NWAKE}	Internal reference, C _{REFIO} = 0.1 μF , C _{REFH/REFL} = 0.1 μF ; $\pm 1\%$ gain error, with respect to steady-state gain		2		μs

Ultra-Low-Power, Octal, 12-Bit, 50MSPS, 1.8V ADC with Serial LVDS Outputs

MAX19527

ELECTRICAL CHARACTERISTICS (continued)

(VAVDD = 1.8V, VOVDD = 1.8V, internal reference, AIN = -0.5dBFS, differential clock, VCLKD = 1.5Vp-p, fCLK = 50MHz, programmable registers at default settings (Table 1), TA = -40°C to +85°C, typical values are at TA = +25°C, unless otherwise noted.) (Note 1)

PARAMETER	SYMBOL	CONDITIONS	MIN	TYP	MAX	UNITS
SERIAL PERIPHERAL INTERFACE (SPI) TIMING (Figure 9, Note 2)						
SCLK Period	tSCLK		50			ns
SCLK to $\overline{\text{CS}}$ Setup Time	tCSS		10			ns
SCLK to $\overline{\text{CS}}$ Hold Time	tCSH		10			ns
SDIO to SCLK Setup Time	tSDS	Serial-data write	10			ns
SDIO to SCLK Hold Time	tSDH	Serial-data write	0			ns
SCLK to SDIO Output Data Delay	tSDD	Serial-data read			10	ns
TIMING CHARACTERISTICS (Figures 6 and 7, Note 2)						
Data Valid to CLKOUT Rise/Fall	tOD		tSAMPLE/ 24 - 0.10	tSAMPLE/ 24 + 0.05	tSAMPLE/ 24 + 0.20	ns
CLKOUT Output-Width High	tCH			tSAMPLE/12		ns
CLKOUT Output-Width Low	tCL			tSAMPLE/12		ns
FRAME Rise to CLKOUT Rise	tDF		tSAMPLE/ 24 - 0.10	tSAMPLE/ 24 + 0.05	tSAMPLE/ 24 + 0.20	ns
Sample CLK Rise to Frame Rise	tSF		tSAMPLE/ 2 + 1.6	tSAMPLE/ 2 + 2.3	tSAMPLE/ 2 + 3.3	ns
POWER REQUIREMENTS						
Analog Supply Voltage	VAVDD		1.7	1.8	1.9	V
Digital Output Supply Voltage	VOVDD		1.7	1.8	1.9	V
Analog Supply Current	IAVDD	8 channels active		158	180	mA
		Incremental channel power-down		-18		
		Nap mode		13	15	
		Sleep mode		0.35	0.5	
Digital Output Supply Current	IOVDD	8 channels active, external RLOAD = 100Ω		87		mA
		Incremental channel power-down		-7.4		
		Nap mode		28		
		Sleep mode		< 0.1		
Total Power Dissipation	PTD	8 channels active		440		mW
		Incremental channel power-down		-46		
		Nap mode		74		
		Sleep mode		0.8		

Note 1: Specifications are 100% production tested at TA ≥ +25°C. Specifications for TA < +25°C are guaranteed by design and characterization.

Note 2: Specifications guaranteed by design and characterization.

Ultra-Low-Power, Octal, 12-Bit, 50Mps, 1.8V ADC with Serial LVDS Outputs

Typical Operating Characteristics

(VAVDD = 1.8V, VOVD = 1.8V, internal reference, AIN = -0.5dBFS, differential clock, VCLKD = 1.5VP-P, fCLK = 50MHz, programmable registers at default settings (Table 1), TA = -40°C to +85°C, typical values are at TA = +25°C, unless otherwise noted. Specifications are 100% production tested at TA ≥ +25°C. Specifications for TA < +25°C are guaranteed by design and characterization.)

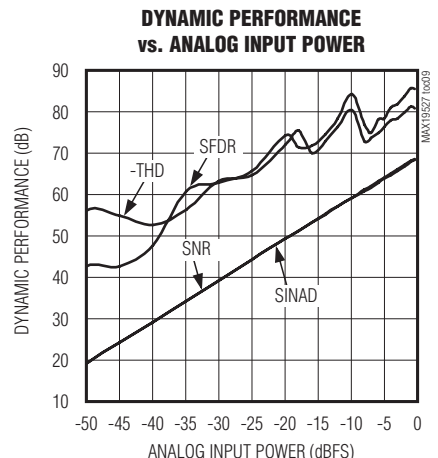
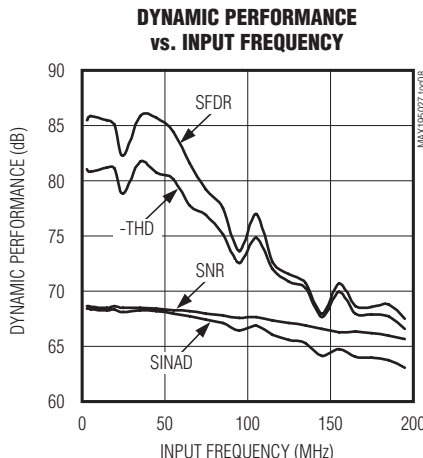
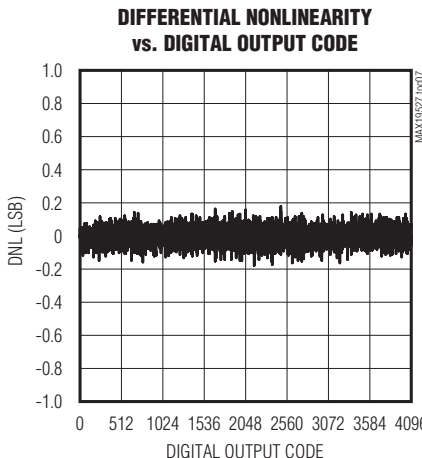
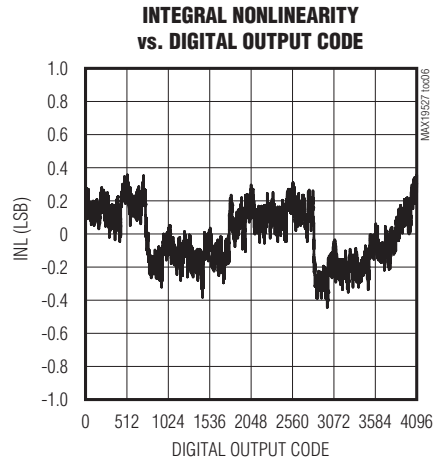
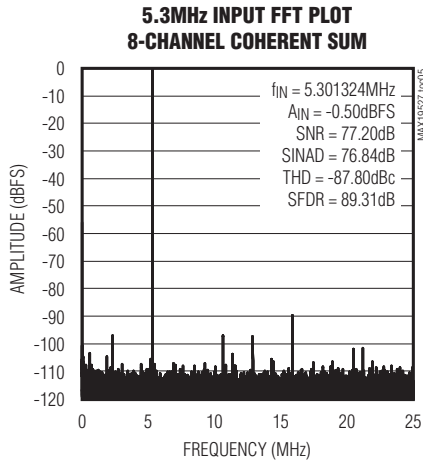
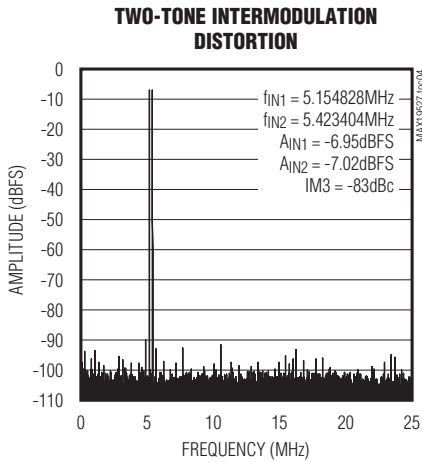
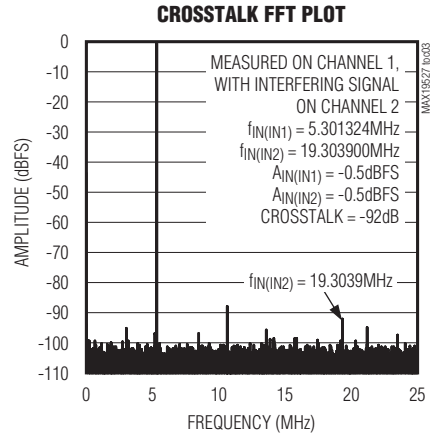
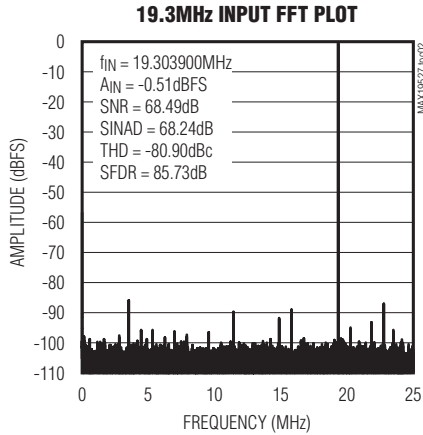
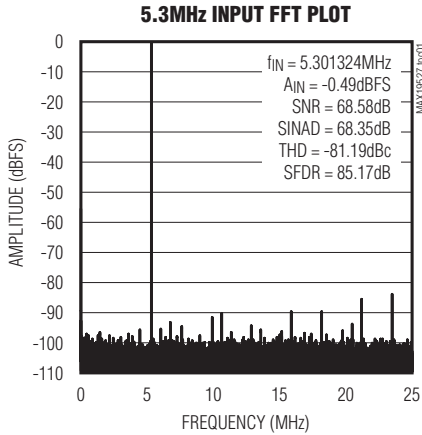

Ultra-Low-Power, Octal, 12-Bit, 50Mps, 1.8V ADC with Serial LVDS Outputs

MAX19527

Typical Operating Characteristics (continued)

($V_{AVDD} = 1.8V$, $V_{OVDD} = 1.8V$, internal reference, $A_{IN} = -0.5dBFS$, differential clock, $V_{CLKD} = 1.5VP-P$, $f_{CLK} = 50MHz$, programmable registers at default settings (Table 1), $T_A = -40^{\circ}C$ to $+85^{\circ}C$, typical values are at $T_A = +25^{\circ}C$, unless otherwise noted. Specifications are 100% production tested at $T_A \geq +25^{\circ}C$. Specifications for $T_A < +25^{\circ}C$ are guaranteed by design and characterization.)

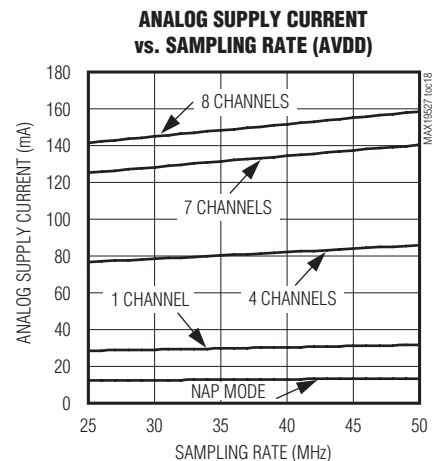
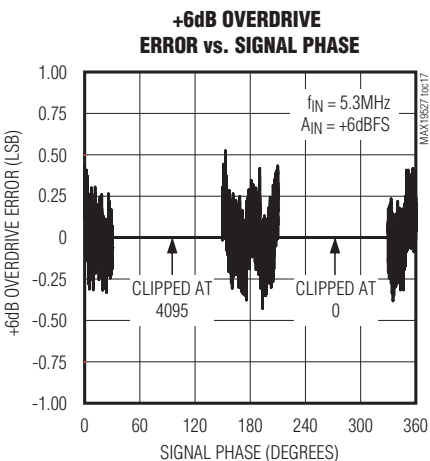
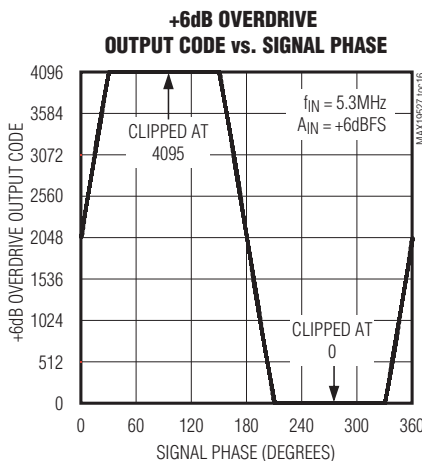
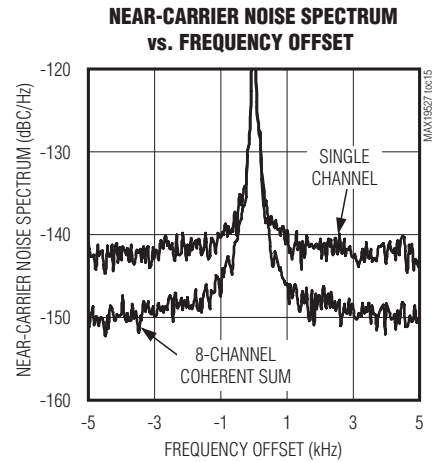
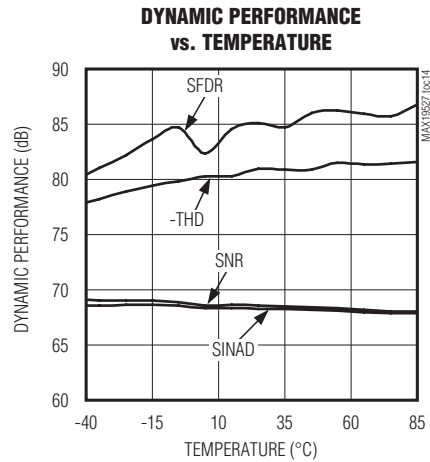
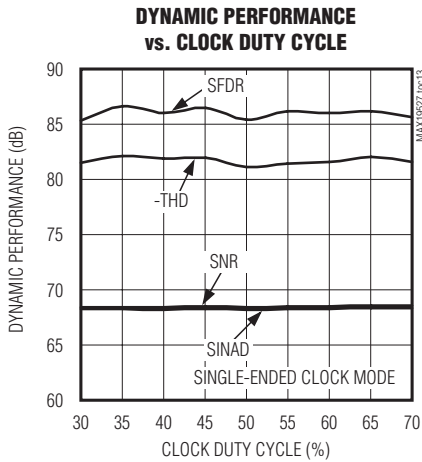
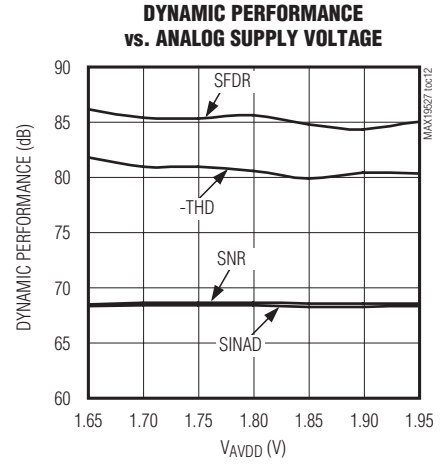
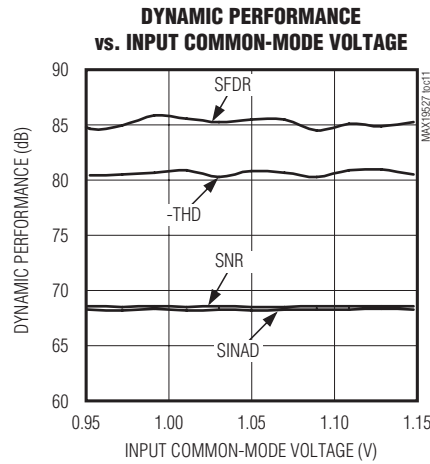
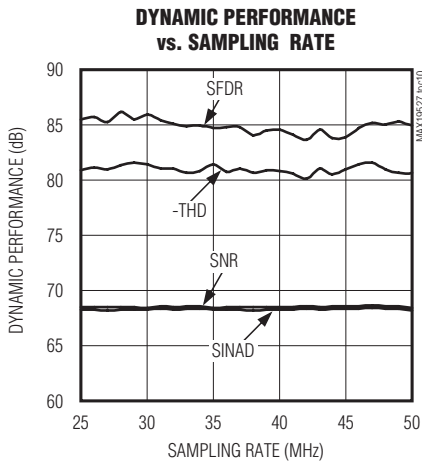

Ultra-Low-Power, Octal, 12-Bit, 50MSPs, 1.8V ADC with Serial LVDS Outputs

Typical Operating Characteristics (continued)

(VAVDD = 1.8V, VOVD = 1.8V, internal reference, AIN = -0.5dBFS, differential clock, VCLKD = 1.5VP-P, fCLK = 50MHz, programmable registers at default settings (Table 1), TA = -40°C to +85°C, typical values are at TA = +25°C, unless otherwise noted. Specifications are 100% production tested at TA ≥ +25°C. Specifications for TA < +25°C are guaranteed by design and characterization.)

ANALOG SUPPLY CURRENT vs. TEMPERATURE (AVDD)

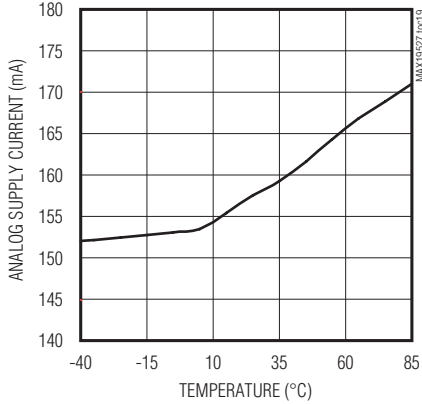

ANALOG SUPPLY CURRENT vs. SUPPLY VOLTAGE (AVDD)

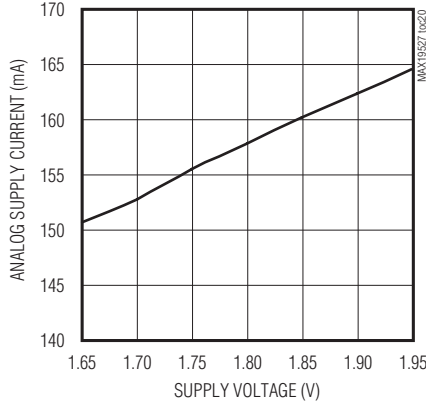

DIGITAL SUPPLY CURRENT vs. SAMPLING RATE (OVDD)

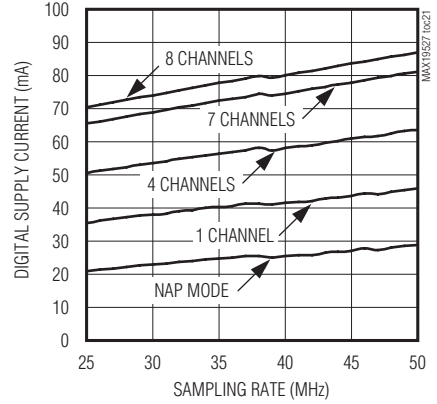

DIGITAL SUPPLY CURRENT vs. TEMPERATURE (OVDD)

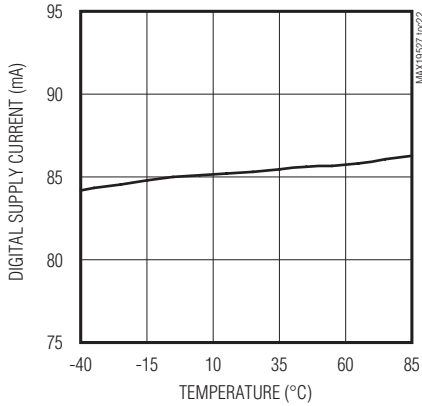

DIGITAL SUPPLY CURRENT vs. SUPPLY VOLTAGE (OVDD)

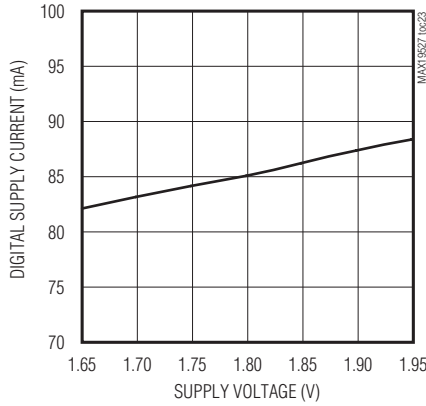

REFERENCE VOLTAGE vs. TEMPERATURE

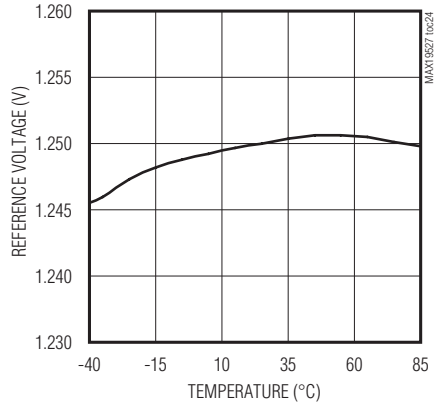

CMOUT VOLTAGE vs. TEMPERATURE

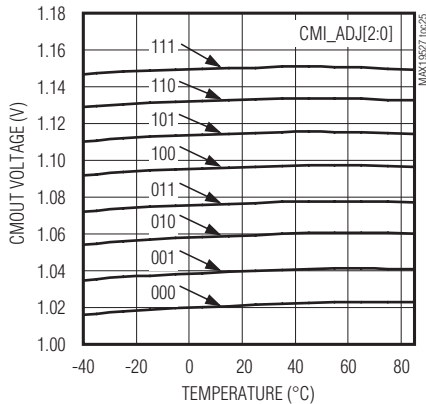

CMOUT VOLTAGE vs. CMOUT LOAD CURRENT

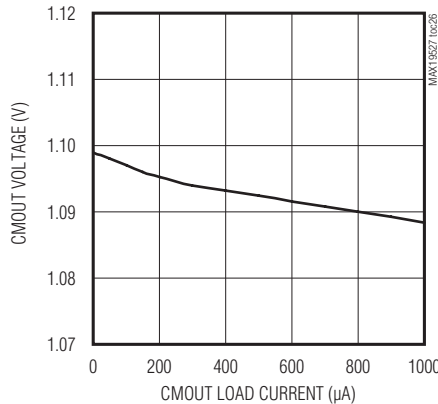

ANALOG INPUT CURRENT vs. INPUT COMMON-MODE VOLTAGE (AVDD)

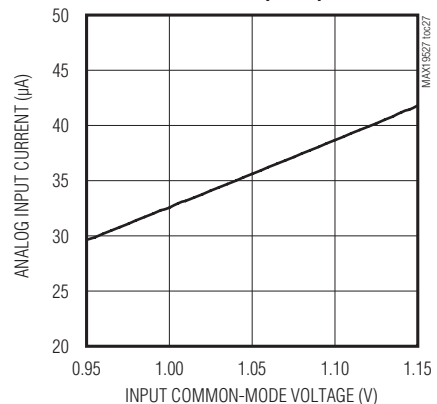

Ultra-Low-Power, Octal, 12-Bit, 50MSPs, 1.8V ADC with Serial LVDS Outputs

Pin Configuration

MAX19527

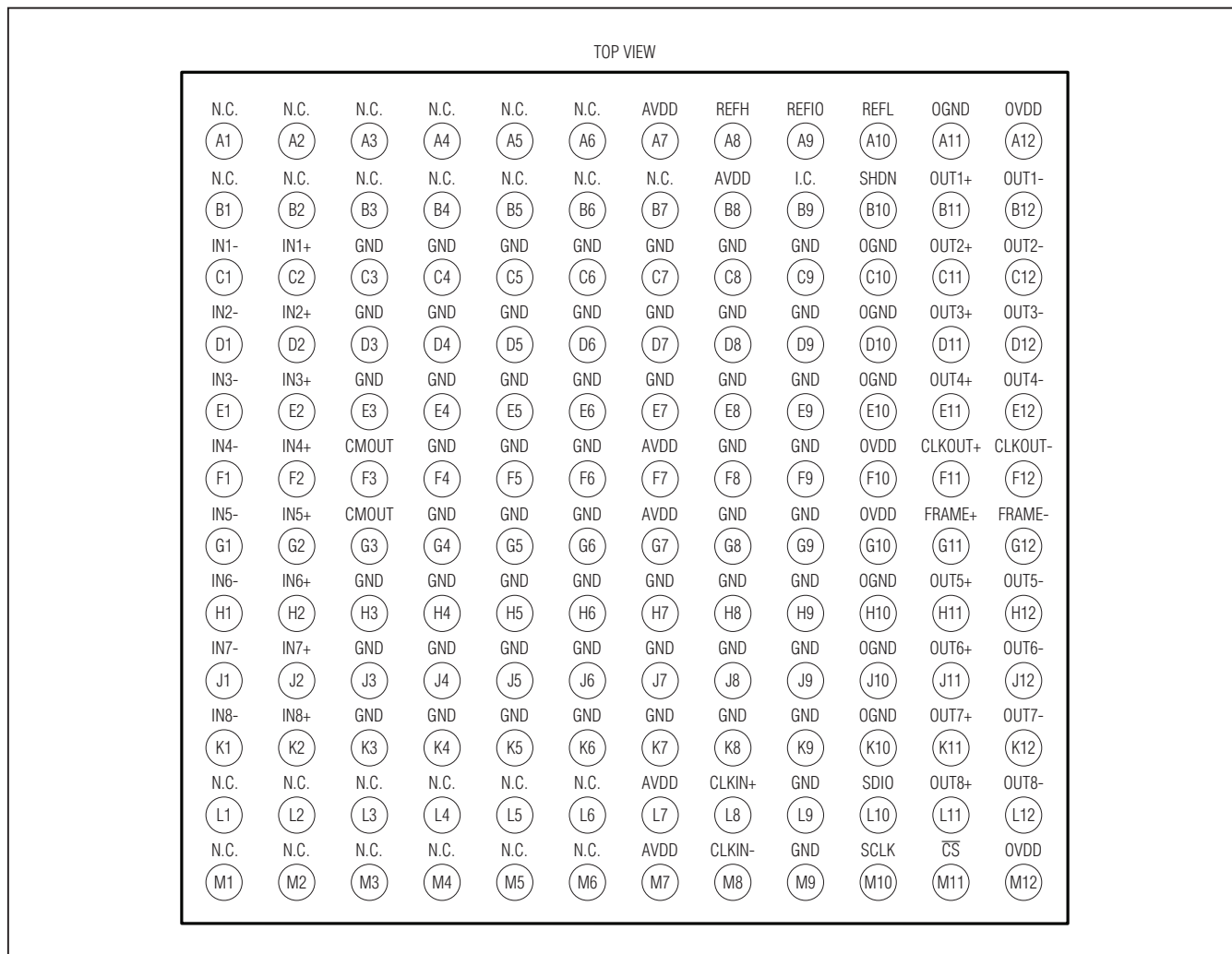

Pin Description

PIN	NAME	FUNCTION
ANALOG INPUTS		
C1	IN1-	Channel 1 Negative (Inverting) Analog Input
C2	IN1+	Channel 1 Positive (Noninverting) Analog Input
D1	IN2-	Channel 2 Negative (Inverting) Analog Input
D2	IN2+	Channel 2 Positive (Noninverting) Analog Input
E1	IN3-	Channel 3 Negative (Inverting) Analog Input
E2	IN3+	Channel 3 Positive (Noninverting) Analog Input
F1	IN4-	Channel 4 Negative (Inverting) Analog Input
F2	IN4+	Channel 4 Positive (Noninverting) Analog Input

Ultra-Low-Power, Octal, 12-Bit, 50Mpsps, 1.8V ADC with Serial LVDS Outputs

Pin Description (continued)

PIN	NAME	FUNCTION
G1	IN5-	Channel 5 Negative (Inverting) Analog Input
G2	IN5+	Channel 5 Positive (Noninverting) Analog Input
H1	IN6-	Channel 6 Negative (Inverting) Analog Input
H2	IN6+	Channel 6 Positive (Noninverting) Analog Input
J1	IN7-	Channel 7 Negative (Inverting) Analog Input
J2	IN7+	Channel 7 Positive (Noninverting) Analog Input
K1	IN8-	Channel 8 Negative (Inverting) Analog Input
K2	IN8+	Channel 8 Positive (Noninverting) Analog Input
L8	CLKIN+	Clock Positive (Noninverting) Input
M8	CLKIN-	Clock Negative (Inverting) Input. If CLKIN- is connected to ground, CLKIN+ is a single-ended, logic-level clock input. Otherwise, CLKIN+ and CLKIN- are self-biased differential clock inputs.
LVDS OUTPUTS		
B11	OUT1+	Channel 1 Positive (Noninverting) LVDS Digital Output
B12	OUT1-	Channel 1 Negative (Inverting) LVDS Digital Output
C11	OUT2+	Channel 2 Positive (Noninverting) LVDS Digital Output
C12	OUT2-	Channel 2 Negative (Inverting) LVDS Digital Output
D11	OUT3+	Channel 3 Positive (Noninverting) LVDS Digital Output
D12	OUT3-	Channel 3 Negative (Inverting) LVDS Digital Output
E11	OUT4+	Channel 4 Positive (Noninverting) LVDS Digital Output
E12	OUT4-	Channel 4 Negative (Inverting) LVDS Digital Output
F11	CLKOUT+	Positive (Noninverting) Serial LVDS Clock Output
F12	CLKOUT-	Negative (Inverting) Serial LVDS Clock Output
G11	FRAME+	Positive (Noninverting) Frame-Alignment LVDS Output. A rising edge on the differential FRAME output aligns to a valid output data frame.
G12	FRAME-	Negative (Inverting) Frame-Alignment LVDS Output. A rising edge on the differential FRAME output aligns to a valid output data frame.
H11	OUT5+	Channel 5 Positive (Noninverting) LVDS Digital Output
H12	OUT5-	Channel 5 Negative (Inverting) LVDS Digital Output
J11	OUT6+	Channel 6 Positive (Noninverting) LVDS Digital Output
J12	OUT6-	Channel 6 Negative (Inverting) LVDS Digital Output
K11	OUT7+	Channel 7 Positive (Noninverting) LVDS Digital Output
K12	OUT7-	Channel 7 Negative (Inverting) LVDS Digital Output
L11	OUT8+	Channel 8 Positive (Noninverting) LVDS Digital Output
L12	OUT8-	Channel 8 Negative (Inverting) LVDS Digital Output
3-WIRE SERIAL PERIPHERAL INTERFACE (SPI)		
L10	SDIO	SPI Data Input/Output
M10	SCLK	SPI Clock
M11	\overline{CS}	SPI Chip Select

Ultra-Low-Power, Octal, 12-Bit, 50MSPS, 1.8V ADC with Serial LVDS Outputs

Pin Description (continued)

MAX19527

PIN	NAME	FUNCTION
REFERENCE		
A8	REFH	High Reference Bypass. Bypass REFH with a 0.1µF capacitor to REFL. See the <i>Reference Configurations</i> section for details.
A9	REFIO	Reference Input/Output. To use internal reference, bypass to GND with a capacitor value of 0.1 µF. See the <i>Reference Configurations</i> section for an external reference.
A10	REFL	Low Reference Bypass. Bypass REFL with a 0.1µF capacitor to REFH. See the <i>Reference Configurations</i> section for details.
SUPPLY AND BIAS		
A7, B8, F7, G7, L7, M7	AVDD	Analog Supply Voltage. Apply 1.8V to all AVDD inputs. Bypass each input to GND with a 0.1µF capacitor.
A11, C10, D10, E10, H10, J10, K10	OGND	Digital Ground. Connect all GND (analog ground) and OGND (digital ground) pins to the board ground plane.
A12, F10, G10, M12	OVDD	Digital Supply Voltage. Digital and output driver supply input. Apply 1.8V to all OVDD inputs. Bypass each input to GND with a 0.1µF capacitor.
B10	SHDN	Active-High Power-Down. Programmable power-management state selection. See the <i>Power Management</i> section for details.
C3–C9, D3–D9, E3–E9, F4, F5, F6, F8, F9, G4, G5, G6, G8, G9, H3–H9, J3–J9, K3–K9, L9, M9	GND	Analog Ground. Connect all GND (analog ground) and OGND (digital ground) pins to the board ground plane.
F3, G3	CMOUT	Common-Mode Output. Input common-mode reference output. Bypass CMOUT with a 1µF capacitor to GND.
OTHER		
A1–A6, B1–B7, L1–L6, M1–M6	N.C.	No Connection. Not internally connected.
B9	I.C.	Internal Connection. Leave I.C. unconnected.

Ultra-Low-Power, Octal, 12-Bit, 50Mps, 1.8V ADC with Serial LVDS Outputs

Simplified Block Diagram

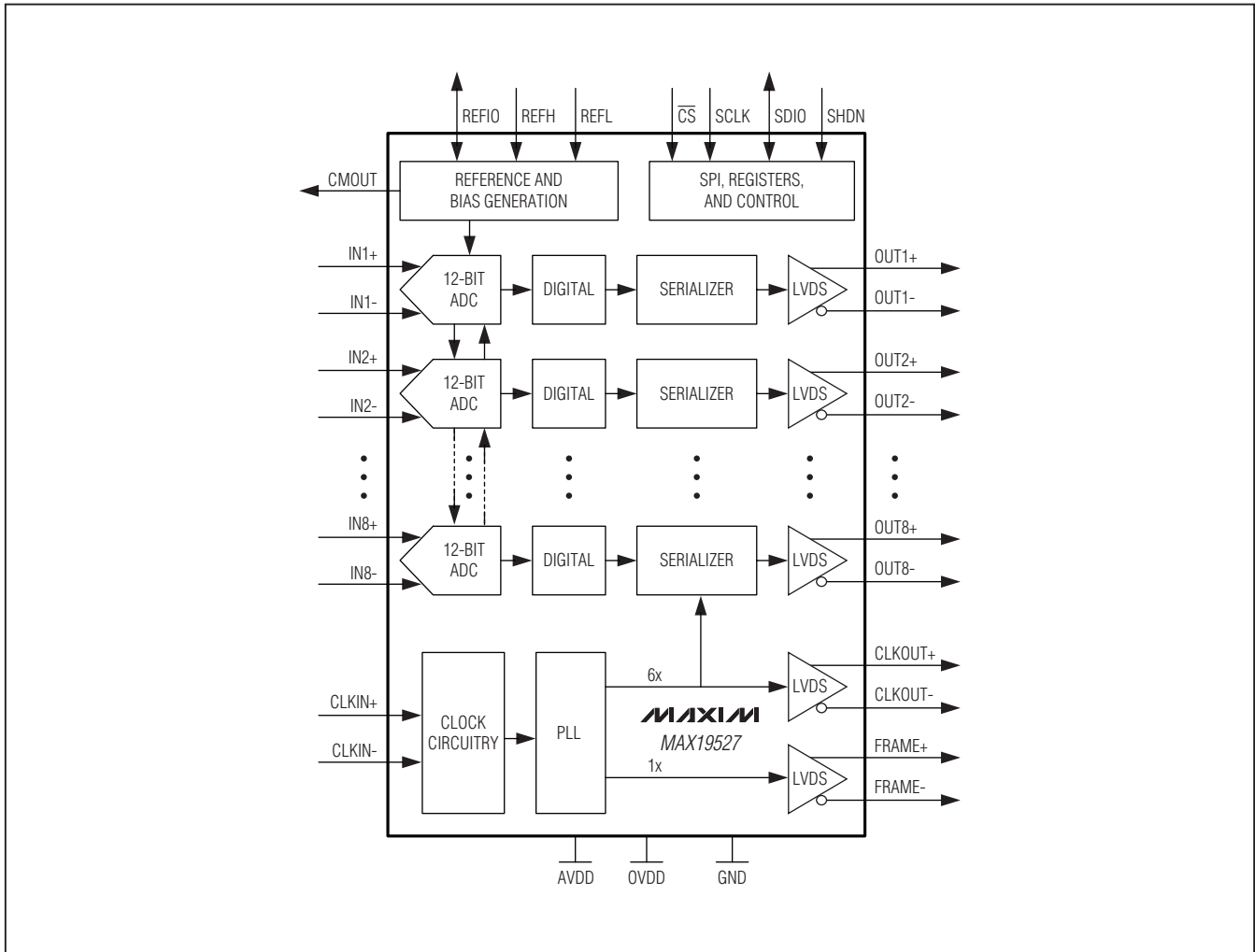

Ultra-Low-Power, Octal, 12-Bit, 50MSPs, 1.8V ADC with Serial LVDS Outputs

Detailed Description

The MAX19527 is an octal, 12-bit, 50MSPs analog-to-digital converter (ADC). The ADC features fully differential inputs, a differential, pipelined architecture with digital error correction, 3-wire SPI-compatible interface for device configuration, serial LVDS digital outputs, and fully configurable power management. The device has an internal precision bandgap reference, but the reference structure also allows the use of an external reference. A flexible clock input circuit allows for a single-ended or differential clock signal, while an on-chip configurable PLL generates the multiplied (6x) clock required for the serial LVDS digital outputs.

The ADC offers eight separate, fully differential channels with synchronized inputs and outputs. The device features a 9-stage, fully differential, pipelined architecture that is ideal for high-speed conversion while minimizing power consumption (Figure 1). Sampled signals taken at a channel input move progressively through the pipeline stages every half clock cycle. From input to serial output, the total latency is 8.5 clock cycles. Each pipeline stage converts its input voltage to a digital output code. At every stage, except the last, the error between the input voltage and the digital output code is multiplied and passed on to the next pipeline stage. Digital error

correction compensates for ADC comparator offsets in each pipeline stage and ensures that there are no missing codes. See the *Simplified Block Diagram*.

Analog Inputs and Common-Mode Reference

Apply the differential analog input signal to the analog inputs (IN₊, IN₋), which are connected to the input sampling switch (Figure 2). When the input sampling switch is closed, the input signal is applied to the sampling capacitors through the input switch resistance. The input signal is sampled at the instant the input switch opens. Carefully balance the input impedance of IN₊ and IN₋ for optimum performance. Before the input switch is closed to begin the next sampling cycle, the sampling capacitors are reset to the input common-mode potential.

Common-mode bias can be provided externally (default) or internally through 2kΩ resistors (programmed). In DC-coupled applications, the signal source provides the external bias and the bias current. In AC-coupled applications, the input current is supplied by the common-mode input voltage. For example, the input current can be supplied through the center tap of a transformer's secondary winding.

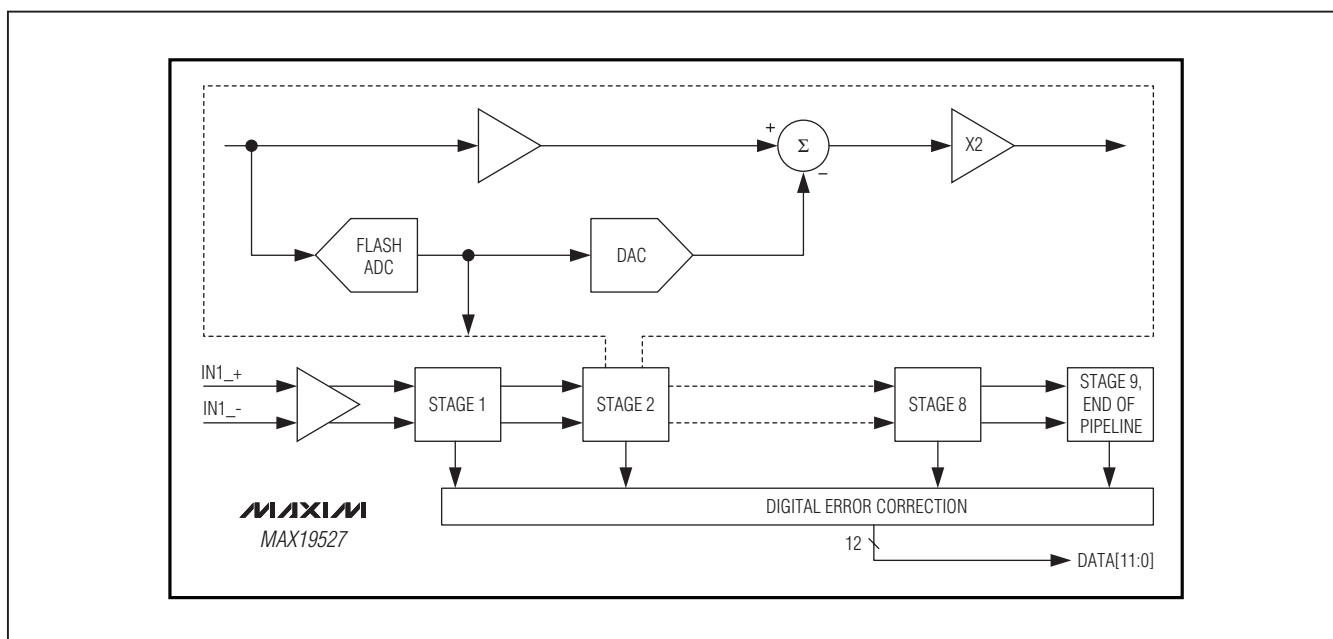

Figure 1. Pipeline Architecture—Stage Blocks

Ultra-Low-Power, Octal, 12-Bit, 50Mps, 1.8V ADC with Serial LVDS Outputs

Alternatively, program the Input Common-Mode Control register (04h, see Tables 17 and 18 for configuration details) through the SPI interface to supply the input DC common-mode voltage and current through internal $2k\Omega$ resistors (Figure 2). When the input current is supplied through the internal resistors, the input common-mode potential is reduced by the voltage drop across the resistors. The common-mode input reference voltage can be adjusted through programmable register settings from 1.020V to 1.160V in 0.020V increments. The default setting is 1.100V. CMOUT can be used to provide a common-mode output reference to a DC-coupled driving circuit.

Reference Configurations

A trimmed internal bandgap voltage generator provides an internal reference voltage of 1.25V. The bandgap voltage is buffered and applied to REFIO through a $10k\Omega$ resistor. The buffered bandgap voltage is applied to a scaling and level-shift circuit, which creates the internal reference potentials (REFH, REFL) that establish the full-scale range of the ADC. A simplified schematic of the reference circuit is shown in Figure 3. Alternatively, REFIO can be driven externally for greater gain accuracy, or to establish a different full-scale range.

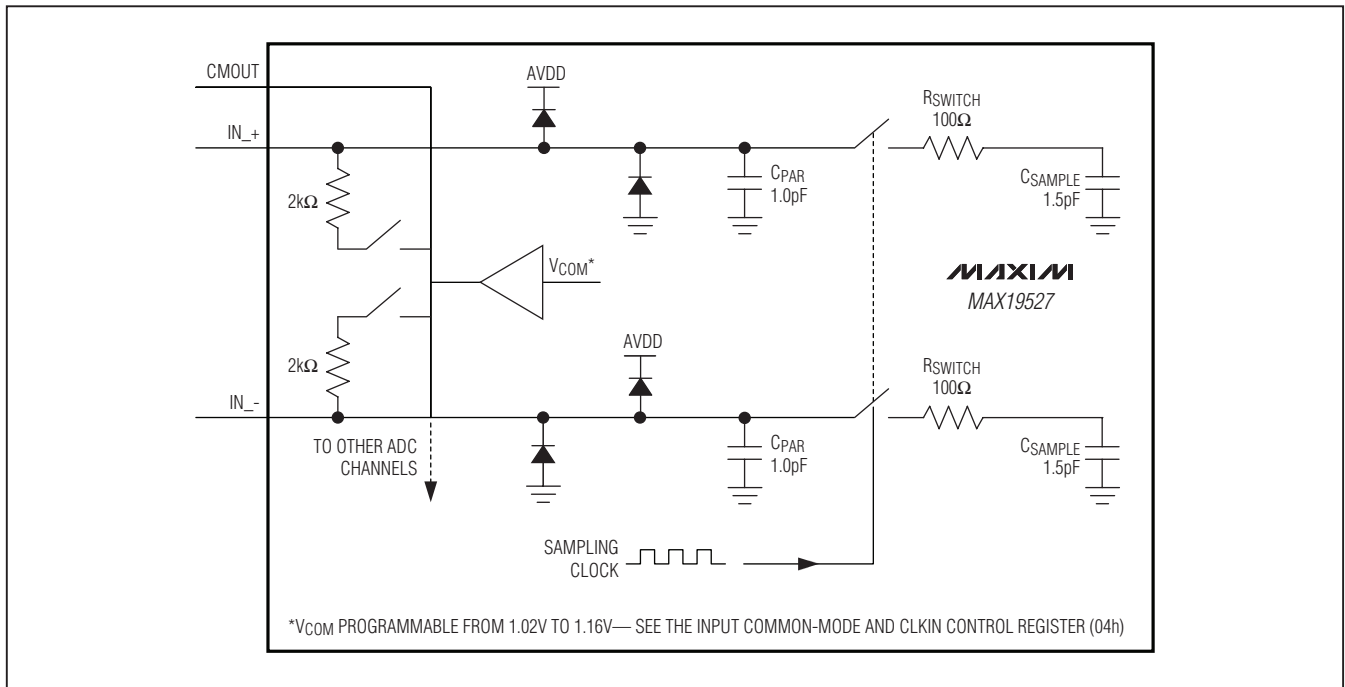

Figure 2. Internal Track-and-Hold (T/H) Circuit

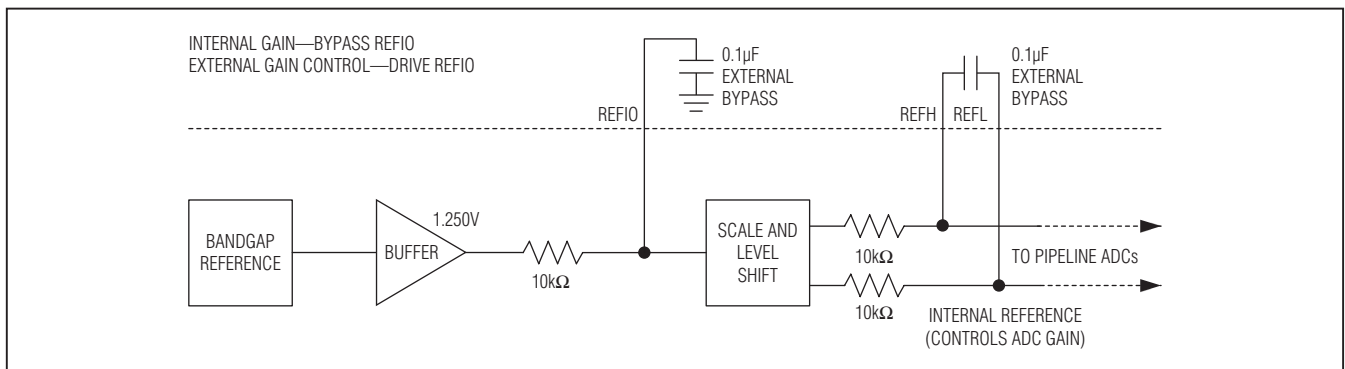

Figure 3. Simplified Reference Schematic

Ultra-Low-Power, Octal, 12-Bit, 50MSPS, 1.8V ADC with Serial LVDS Outputs

Internal Reference Mode

In a typical application, the internal absolute gain accuracy is sufficient and the internal reference is used to establish the full-scale range of the ADC. An external 0.1 μ F bypass capacitor from REFIO to GND is recommended. An external bypass capacitor placed across REFH and REFL is required to achieve optimal near-carrier noise performance, and a value of 0.1 μ F is recommended to achieve the performance specified in the *Electrical Characteristics* table.

When using sleep mode for power management, the wake-up time is determined by the reference-bypass capacitor values. The wake-up from sleep-mode characteristic appears as ADC gain vs. time where the ADC full-scale voltage is to first order a 2-pole response. The first pole is established by the RC time constant on pin REFIO. The second pole is established by the RC time constant on pins REFH and REFL. When the recommended capacitor values are used, the wake-up from sleep time is 10ms. When nap mode is used for power management, the reference remains powered on and the wake-up time from nap mode is not affected by the reference bypass capacitance values.

External Reference Mode

In applications where control over the full-scale range of the ADC is desired, an external voltage of 1.25V can be applied to REFIO. For optimal performance, the recommended adjustment range is limited to +5/-15%. The REFIO-to-ADC gain-transfer function is:

$$V_{FS} = 1.5 \times [V_{REFIO}/1.25]$$

As in the case of internal reference mode, apply a 0.1 μ F capacitor across pins REFH and REFL to achieve optimal near-carrier noise performance and provide noise filtering of the external reference source.

Clock Input

The input clock interface provides for flexibility in the requirements of the clock driver. The device accepts a fully differential clock or single-ended logic-level clock. The device is specified for an input sampling frequency range of 25MHz to 50MHz. By default, the internal PLL is configured to accept input clock frequencies from 39MHz to 50MHz. The PLL is programmed through the PLL Sampling Rate register (00h, Table 2). Table 3 details the complete range of PLL sampling frequency settings.

For differential clock operation, connect a differential clock to the CLKIN+ and CLKIN- inputs. The input common mode is established internally to allow for AC-coupling. The self-biased input common-mode voltage defaults to 1.2V. The differential clock signal can also be DC-coupled if the externally established common-mode voltage is constrained to the specified clock input common-mode range of 1.0V to 1.4V. A differential input termination of 100 Ω can be switched in by programming the CLKIN Control register (04h[4], Table 17).

For single-ended operation, connect CLKIN- to GND and drive the CLKIN+ input with a logic-level signal. When the CLKIN- input is grounded (or pulled below the threshold of the clock-mode detection comparator), the differential-to-single-ended conversion stage is disabled and the logic-level inverter path is activated. The input common-mode self-bias is disconnected from CLKIN+, and provides a weak pullup bias to AVDD for CLKIN- during single-ended clock operation (Figure 4).

System Timing Requirements

Figure 5 shows the relationship between the analog inputs, input clock, frame-alignment output, serial-clock output, and serial-data outputs. The differential analog input (IN+, IN-) is sampled on the rising edge of the applied clock signal (CLKIN+, CLKIN-) and the resulting data appears at the digital outputs 8.5 clock cycles later. Figure 6 provides a detailed, two-conversion timing diagram of the relationship between inputs and outputs.

Clock Output (CLKOUT+, CLKOUT-)

The ADC provides a differential clock output that consists of CLKOUT+ and CLKOUT-. As shown in Figure 6, the serial output data is clocked out of the device on both edges of the clock output. The frequency of the output clock is six times (6x) the frequency of the input clock. The Output Data Format and Test Pattern register (01h) allows the phase of the clock output to be adjusted relative to the output data frame (Table 5, Figure 10).

Frame-Alignment Output (FRAME+, FRAME-)

The ADC provides a differential frame-alignment signal that consists of FRAME+ and FRAME-. As shown in Figure 6, the rising edge of the frame-alignment signal corresponds to the first bit (D0) of the 12-bit serial-data stream. The frequency of the frame-alignment signal is identical to the frequency of the input clock; however, the duty cycle varies depending on the input clock frequency.

Ultra-Low-Power, Octal, 12-Bit, 50Mps, 1.8V ADC with Serial LVDS Outputs

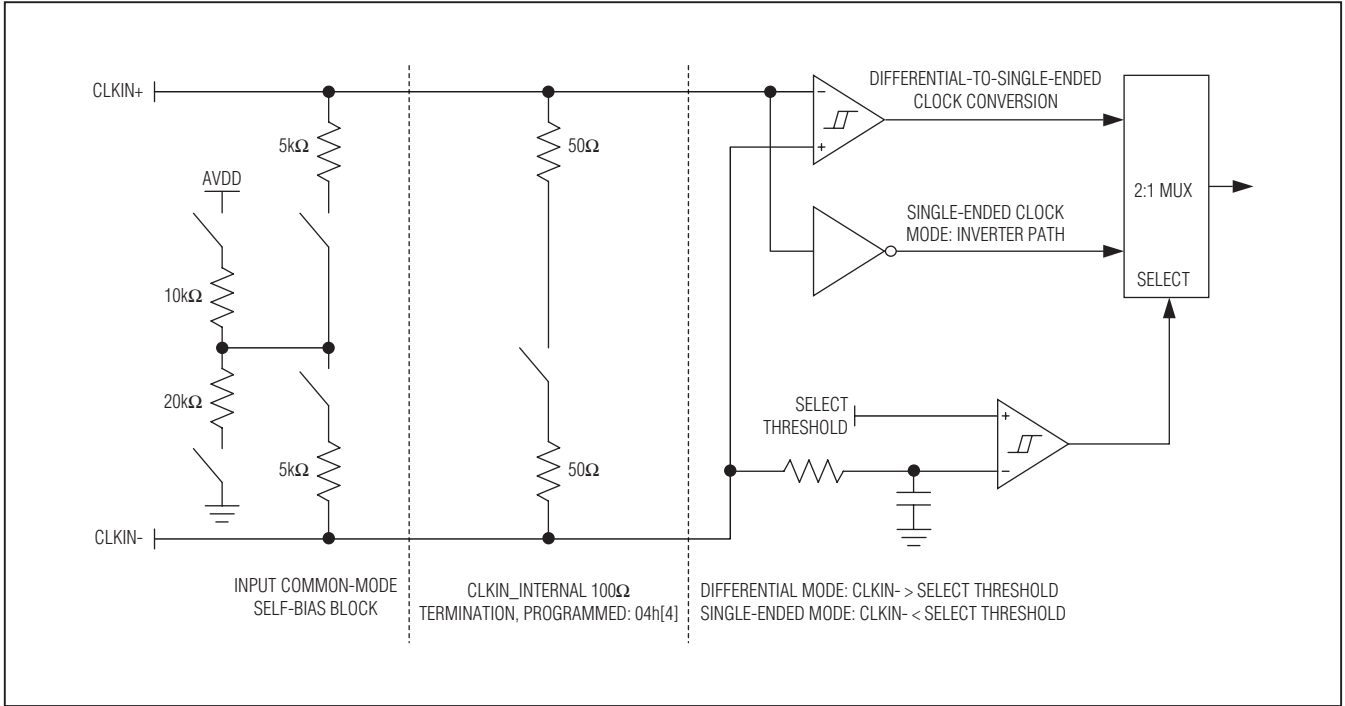

Figure 4. Simplified Clock Input Schematic

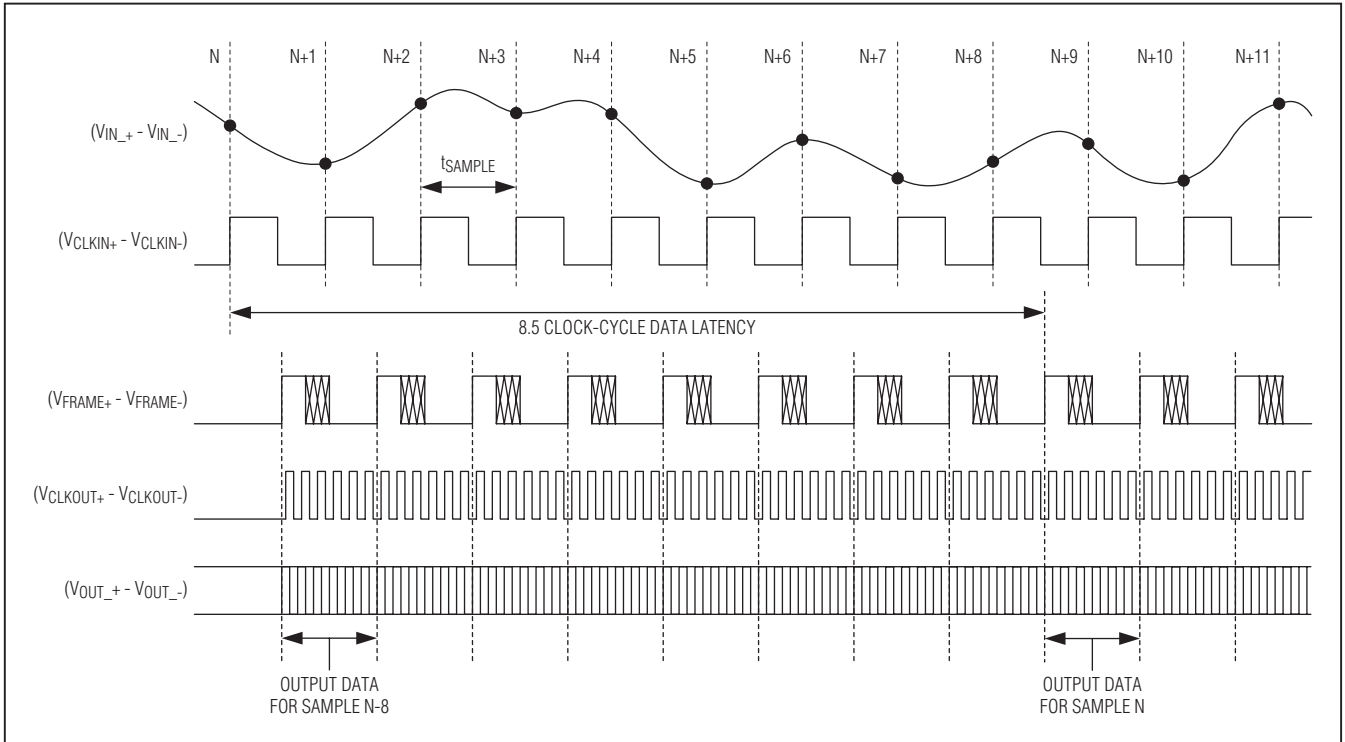

Figure 5. Global Timing Diagram

Ultra-Low-Power, Octal, 12-Bit, 50MSPs, 1.8V ADC with Serial LVDS Outputs

Serial Output Data (OUT₊, OUT₋)

The ADC provides conversion results through individual differential outputs consisting of OUT₊ and OUT₋. The results are valid 8.5 input clock cycles after a sample is taken. As shown in Figure 5, the output data is clocked out on both edges of the output clock, LSB (D0) first (by default). Figure 7 displays the detailed serial-output timing diagram.

Differential LVDS Digital Outputs

The ADC features programmable, fully differential LVDS digital outputs. By default, the 12-bit data output is transmitted LSB first, in offset binary format. The Output Data Format and Test Pattern register (01h, Table 5) allows customization of the output bit order and data format. The output bit order can be reconfigured to

transmit MSB first, and the output data format can be changed to two's complement. Table 6 contains full output data configuration details.

The LVDS outputs feature flexible programming options. First, the output common-mode voltage can be programmed from 0.6V to 1.2V (default) in 200mV steps (Table 13). Use the LVDS Output Driver Level register (02h, Table 9) to adjust the output common-mode voltage.

The LVDS output driver current is also fully programmable through the LVDS Output Driver Management register (03h, Table 14). By default, the output driver current is set to 3.5mA. The output driver current can be adjusted from 0.5mA to 7.5mA in 0.5mA steps (Table 15).

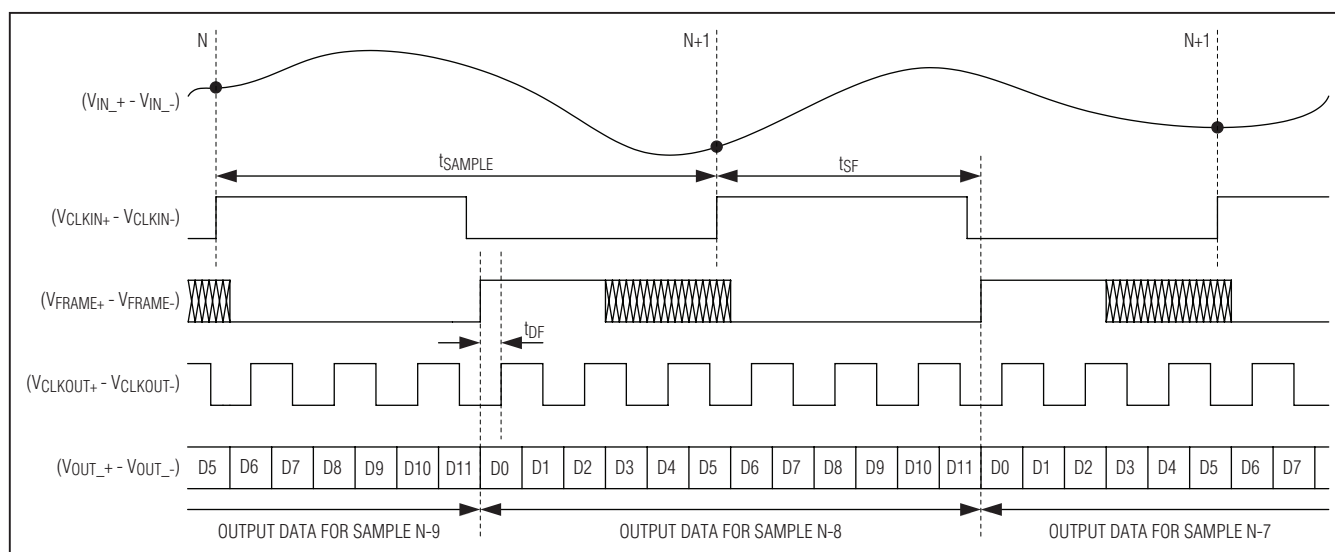

Figure 6. Detailed Two-Conversion Timing Diagram

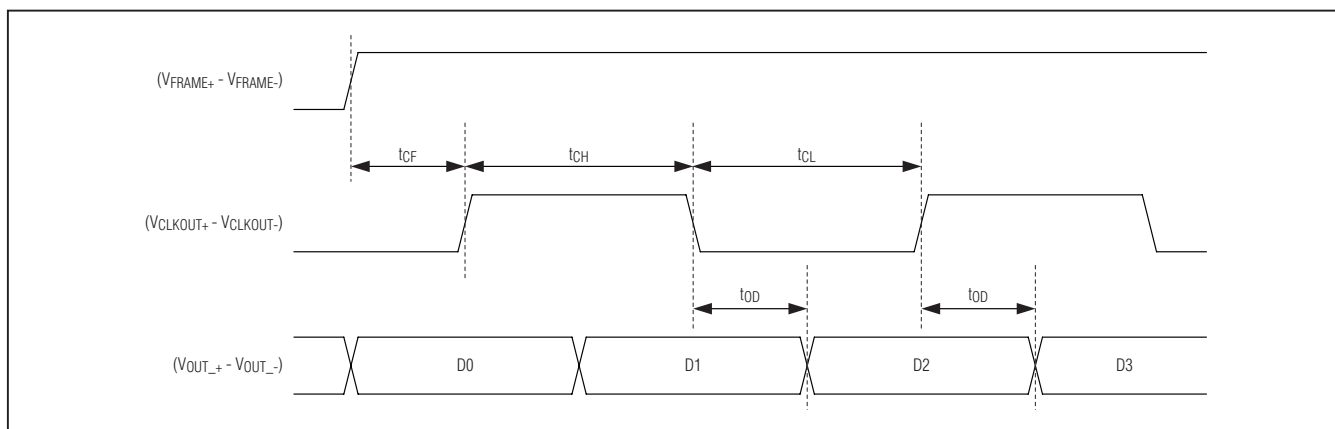

Figure 7. Serial-Output Detailed Timing Diagram

Ultra-Low-Power, Octal, 12-Bit, 50MSPs, 1.8V ADC with Serial LVDS Outputs

The LVDS output drivers also feature optional internal termination that can be enabled and adjusted by the LVDS Output Driver Management register (03h, Table 14). By default, the internal output driver termination is disabled. See Table 16 for all possible configurations.

Output Driver Level Tests

The LVDS outputs (data, clock, and frame) can be configured to static logic-level test states through the LVDS Output Driver Level register (02h, Table 9). The complete list of settings for the static logic-level test states can be found in Tables 10, 11, and 12.

Data Output Test Patterns

The LVDS data outputs can be configured to output several different, recognizable test patterns. Test patterns are enabled and selected using the Output Data Format and Test Pattern register (01h, Table 5). A complete list of test pattern options is listed in Table 7, and custom test pattern details can be found in the *Custom Test Pattern Registers (07h, 08h, 09h)* section (including Tables 21, 22, and 23).

Power Management

The SHDN input is used to toggle between two power-management states. Power state 0 corresponds to SHDN = 0, while power state 1 corresponds to SHDN = 1. The PLL Sampling Rate and Power Management register (00h) and the Channel Power Management registers (05h and 06h) fully define each power-management state. By default, SHDN = 1 shuts down the device and SHDN = 0 returns the ADCs to full-power operation. Use of the SHDN input is not required for power management.

For either state of SHDN, complete power-management flexibility is provided, including individual ADC channel power-management control, as well as the option of which reduced power-mode to utilize in each power state. The available reduced-power modes are called sleep mode and nap mode. The device cannot enter either of these states unless no ADC channels are active in the current power state (Table 4).

In nap mode, the reference, duty-cycle equalizer, and clock-multiplier PLL circuits remain active for rapid wake-up time. In nap mode, the externally applied clock signal must remain active for the duty-cycle equalizer and PLL to remain locked. Typical wake-up time from nap mode is 2 μ s.

In sleep mode, all circuits are turned off except for the bandgap voltage-generation circuit. All registers retain

previously programmed values during sleep mode. Typical wake-up time from sleep mode is 10ms, which is dominated by the RC time constants on REFIO and REFH/REFL.

Power On and Reset

The user-programmable register default settings and other factory-programmed settings are stored in a non-volatile memory. Upon device power-up, these values are loaded into the control registers. The operation occurs after the application of a valid supply voltage to AVDD and OVDD, and the presence of an input clock signal. The user-programmed register values are retained as long as the AVDD and OVDD voltages are applied.

A reset condition overwrites all user-programmed registers with the default factory values. The reset condition occurs on power-up and can be initiated while powered with a software write command (write 5Ah) through the serial-port interface to the Special Function register (10h). The reset time is proportional to the ADC clock period and requires 415 μ s at 50MSPs.

3-Wire Serial Peripheral Interface (SPI)

The ADC operates as a slave device that sends and receives data through a 3-wire SPI interface. A master device must initiate all data transfers to and from the device. The device uses an active-low SPI chip-select input (\overline{CS}) to enable communication with timing controlled through the externally generated SPI clock input (SCLK). All data is sent and received through the bidirectional SPI data line (SDIO). The device has 10 user-programmable control registers and one special-function register, which are accessed and programmed through this interface.

SPI Communication Format

Figure 8 shows an ADC SPI communication cycle. All SPI communication cycles are made up of two bytes of data on SDIO and require 16 clock cycles on SCLK to be completed. To initiate an SPI read or write communication cycle, \overline{CS} must first transition from a logic-high to a logic-low state. While \overline{CS} remains low, serial data is clocked in from SDIO on rising edges of SCLK and clocked out (for a read) on the falling edges of SCLK. When \overline{CS} is high, the device does not respond to SCLK transitions, and no data is read from or written to SDIO. \overline{CS} must transition back to logic-high after each read/write cycle is completed.

Ultra-Low-Power, Octal, 12-Bit, 50MSPs, 1.8V ADC with Serial LVDS Outputs

The first byte transmitted on SDIO is always provided by the master. The ADC (slave device) clocks in the data from SDIO on each rising edge of SCLK. The first bit received selects whether the communication cycle is a read or write. Logic 1 selects a read cycle, while logic 0 selects a write cycle. The next 7 bits (MSB first) are the register address for the read or write cycle. The address can indicate any of the 10 user-programmable control registers (00h to 09h), or the special-function register (10h, write only). Attempting to read/write with any other address has no effect (Table 1).

The second byte on SDIO is sent to the ADC in the case of a write, or received from the ADC in the case of a read. For a write command, the device continues to clock in the data on SDIO on each rising edge of SCLK. In the case of a read command, the device writes data to SDIO on each falling edge of SCLK. The data byte is transmitted

and received MSB first in both cases. The detailed SPI timing requirements are shown in Figure 9.

User-Programmable Control Registers

The ADC has 10 user-programmable control registers, and one special-function register (Table 1). Each register is set to its power-on-reset (POR) default value when the device powers up or after a reset condition clears.

PLL Sampling Rate and Power Management Register (00h)

The PLL Sampling Rate and Power-Management register (00h, Table 2) has two distinct functions. The first is to adjust the internal PLL to facilitate a wide range of input sampling frequencies. The second is to set the type of power-down mode used by each power state (set by SHDN).

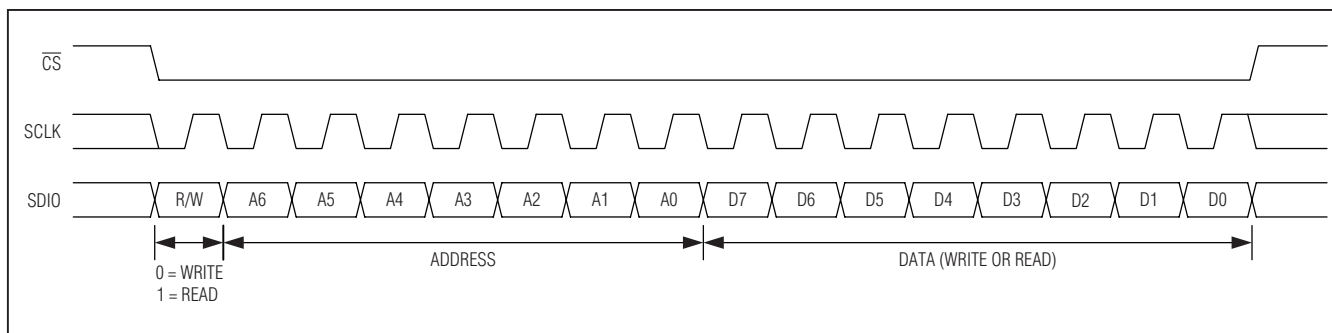

Figure 8. SPI Communication Cycle

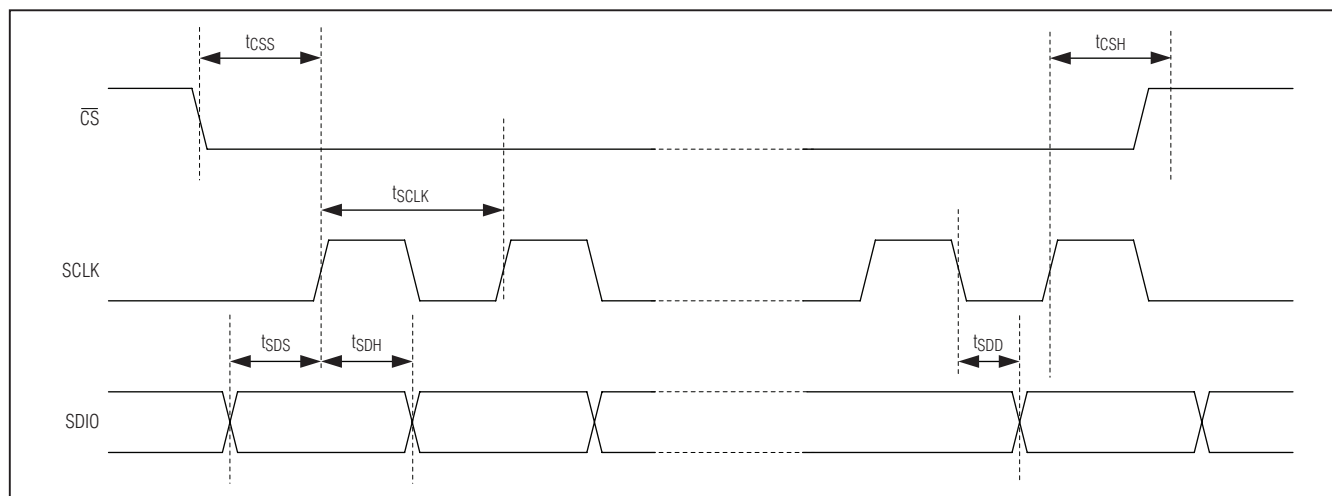

Figure 9. SPI Timing Diagram

Ultra-Low-Power, Octal, 12-Bit, 50MSPs, 1.8V ADC with Serial LVDS Outputs

The PLL[2:0] bits (00h[6:4]) are used to program the clock multiplier for the internal PLL in order to set the input sampling frequency range. The default setting is PLL[2:0] = 001, which allows for 39MHz to 50MHz operation. See Table 3 for the full range of PLL settings and the corresponding sampling frequencies.

The NAP_SHDN1 (00h[1]) and NAP_SHDN0 (00h[0]) bits are used to set the state of the ADC when all channels are turned off for the SHDN = 1 and SHDN = 0 power-management states, respectively. When they are set to logic 0, the device enters sleep mode if no channels are enabled in that power state. When they are set to logic 1, the device instead enters nap mode if no channels are enabled for that power state. If even one channel

is active in the current power state, the device cannot enter nap or sleep mode (Table 4). The default states are NAP_SHDN1 = 0 and NAP_SHDN0 = 1, meaning that if all channels are disabled in the corresponding power state, SHDN = 1 corresponds to sleep mode and SHDN = 0 corresponds to nap mode.

Output Data Format and Test Pattern Register (01h)

The Output Data Format and Test Pattern register (01h, Table 5) has several functions. The first is used to adjust the LVDS output bit order and data format. The second is used to set the CLKOUT phase with respect to the output frame. Finally, this register is used to enable and select test pattern outputs.

Table 1. Summary of User-Programmable Control Registers

ADDRESS	READ/WRITE	POR STATE	FUNCTION
00h	R/W	0001-0001	PLL sampling rate and power management
01h	R/W	0000-0000	Output data format and test patterns
02h	R/W	0000-0000	LVDS output driver level
03h	R/W	0000-0000	LVDS output driver management
04h	R/W	0000-1000	Input common mode and CLKIN control
05h	R/W	1111-1111	Channel power management: SHDN0
06h	R/W	0000-0000	Channel power management: SHDN1
07h	R/W	1010-1010	Custom test patterns 1
08h	R/W	0101-0101	Custom test patterns 2
09h	R/W	0101-1010	Custom test patterns 3
0Ah to 0Fh	—	Reserved	Reserved registers (do not use)
10h	R/W	—	Special function

Table 2. PLL Sampling Rate and Power Management (00h)

BIT 7	BIT 6	BIT 5	BIT 4	BIT 3	BIT 2	BIT 1	BIT 0
—	PLL[2:0]			—	—	NAP_SHDN1	NAP_SHDN0

Table 3. PLL Frequency Control Settings (00h[6:4])

CLOCK MULTIPLIER SETTING			MINIMUM SAMPLING FREQUENCY (MHz)	MAXIMUM SAMPLING FREQUENCY (MHz)
PLL[2]	PLL[1]	PLL[0]		
0	0	0	Not used	
0	0	1	39	50
0	1	0	28.5	39
0	1	1	25	28.5
1	X	X	Not used	

X = Don't care.

Ultra-Low-Power, Octal, 12-Bit, 50MSPs, 1.8V ADC with Serial LVDS Outputs

The LVDS data output format can be adjusted using the DATA_FORMAT bit (01h[1]) and the BIT_ORDER bit (01h[0]). The default state for both is logic 0, corresponding to a binary digital output code, presented LSB first. Setting BIT_ORDER to logic 1 changes the LVDS output data to an MSB-first format. Setting DATA_FORMAT to logic 1 changes the LVDS output format from binary to two's complement. Table 6 contains the LVDS output data format programming details.

The phase of the serial LVDS output clock (CLKOUT) can be adjusted, relative to the output data frame, by using the CLKOUT_PHASE[1:0] bits (01h[3:2]). The default state for CLKOUT_PHASE[1:0] is 00, and by changing this value the default phase relationship can be adjusted in 90° increments. Figure 10 illustrates both the default phase relationship (between an output data frame and the output clock), as well as the other three settings (shown with the default LSB first output data format).

The serial LVDS outputs also feature programmable test patterns for data timing alignment. By default,

the TEST_DATA bit (01h[4]) is set to logic 0, enabling normal channel data outputs. By setting TEST_DATA to logic 1, test data output patterns are enabled. The ADC has five preset test data output settings, as well as one custom pattern setting (custom test patterns are programmed through registers 07h, 08h, and 09h). The TEST_PATTERN[2:0] bits (01h[7:5]) are used to select the type of output test pattern. All test patterns consist of a sequence of one or more 12-bit data frames. Table 7 contains the test pattern programming details.

Pseudo-random data patterns are bit sequences without regard to bit position within the frame. The short sequence repeats every $2^9 - 1$ (511) bits. The bit sequence is generated according to the ITU-T 0.150 standard, with an initial value shown in Table 8. The long sequence repeats every $2^{23} - 1$ (8,388,607) bits according to ITU-T 0.150 with an initial value shown in Table 8 and an inverted bit stream.

Table 4. Power-Management Programming Table

SHDN	NAP_SHDN0 00h[0]	CHx_SHDN0 05h[7:0]	NAP_SHDN1 00h[1]	CHx_SHDN1 06h[7:0]	MAX19527 STATE
0	0	0000-0000	X	XXXX-XXXX	Sleep mode
0	1	0000-0000	X	XXXX-XXXX	Nap mode
0	X	One or more bits set to 1	X	XXXX-XXXX	Active mode
1	X	XXXX-XXXX	0	0000-0000	Sleep mode
1	X	XXXX-XXXX	1	0000-0000	Nap mode
1	X	XXXX-XXXX	X	One or more bits set to 1	Active mode

X = Don't care.

Table 5. Output Data Format and Test Pattern (01h)

BIT 7	BIT 6	BIT 5	BIT 4	BIT 3	BIT 2	BIT 1	BIT 0
TEST_PATTERN[2:0]		TEST_DATA		CLKOUT_PHASE[1:0]		DATA_FORMAT	BIT_ORDER

Table 6. LVDS Output Data Format Programming

DATA_FORMAT	BIT_ORDER	LVDS OUTPUT DATA FORMAT
0	0	Binary, LSB first (default)
0	1	Binary, MSB first
1	0	Two's complement, LSB first
1	1	Two's complement, MSB first

Ultra-Low-Power, Octal, 12-Bit, 50MSPs, 1.8V ADC with Serial LVDS Outputs

LVDS Output Driver Level Register (02h)

Use the LVDS Output Driver Level register (02h, Table 9) to test the LVDS output driver static logic levels (OUT_, CLKOUT_, FRAME_) and to set the output common-mode voltage for all LVDS outputs.

To test the LVDS outputs at static logic levels, the TEST_FRAME_LEVEL[1:0], TEST_CLKOUT_LEVEL[1:0], and TEST_DATA_LEVEL[1:0] bits (02h[5:0]) are used. The LSB of each, when set to logic 0 (default), disables the static output level test (normal data output). When the LSB of each is set to logic 1, the static output level test

is enabled. The MSB of each is then used to determine if the static output is logic 1 or 0 (matches the logic state of the MSB). For detailed programming information, see Tables 10, 11, and 12.

To set the LVDS output common-mode voltage, use the LVDS_CM[1:0] bits (02h[7:6]). By default, LVDS_CM[1:0] is set to 00, which corresponds to a default setting of 1.2V for the LVDS output common-mode voltage. Table 13 contains complete programming details.

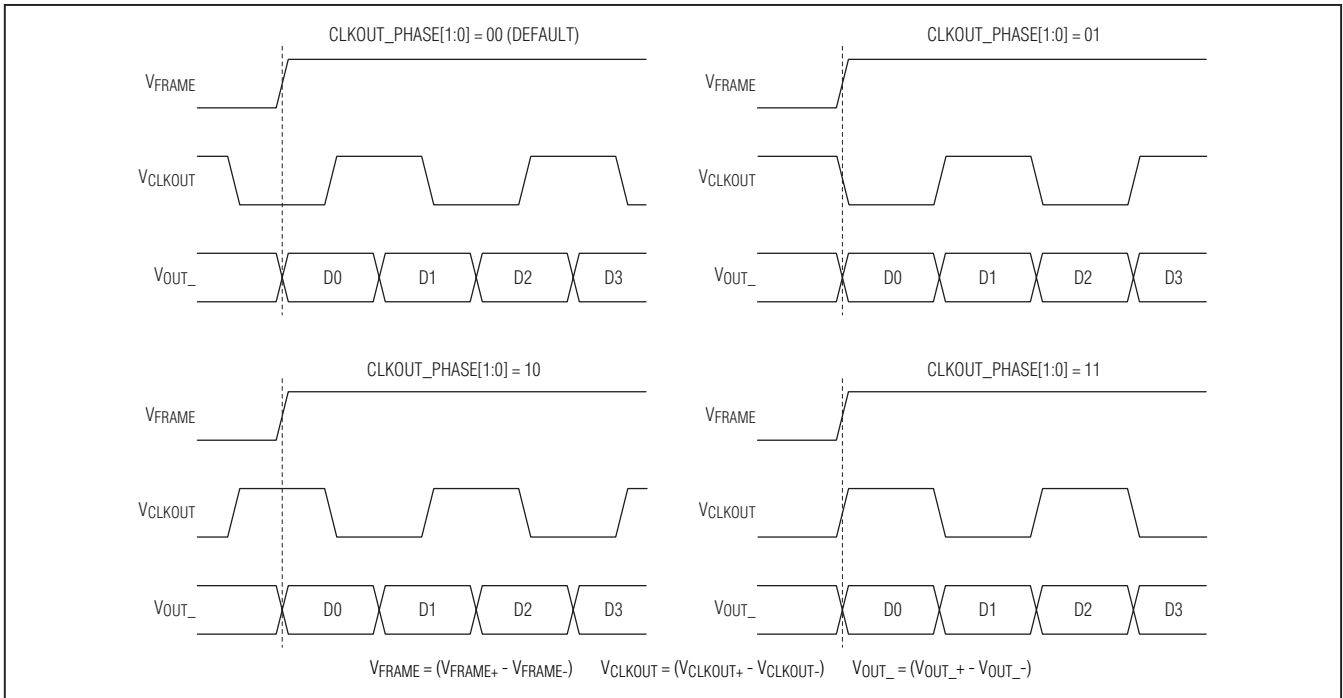

Figure 10. Serial LVDS Output Clock (CLKOUT) Phase Adjustment

Table 7. Test Pattern Programming

TEST_DATA	TEST_PATTERN[2:0]			TEST PATTERN FORMAT
0	X	X	X	Disabled, normal data output (default)
1	0	0	0	Data skew (0101010101), repeats every frame
1	0	0	1	Data sync (111111000000), repeats every frame
1	0	1	0	Custom test pattern, repeats every two frames
1	0	1	1	Ramping pattern from 0 to 4095 (repeats)
1	1	0	0	Pseudo-random data pattern, short sequence (2 ⁹)
1	1	0	1	Pseudo-random data pattern, long sequence (2 ²³)
1	1	1	0	Not used
1	1	1	1	Not used

X = Don't care.

Ultra-Low-Power, Octal, 12-Bit, 50MSPs, 1.8V ADC with Serial LVDS Outputs

LVDS Output Driver Management Register (03h)

Use the LVDS Output Driver Management register (03h, Table 14) to set the LVDS output drive current and to enable and set the value of the internal LVDS output termination.

The LVDS output drive current is fully configurable through the LVDS_IADJ[3:0] bits (03h[3:0]). The default setting for LVDS_IADJ[3:0] is 0000, which corresponds to a 3.5mA output drive current (350mV at 100Ω). The output drive current can be reprogrammed from 0.5mA to 7.5mA in 0.5mA increments. Table 15 contains complete programming details.

The LVDS output driver features optional internal termination that is programmable through the LVDS_TERM[2:0] bits (03h[6:4]). By default, LVDS_TERM[2:0] is set to 000, disabling the optional internal termination. Table 16 contains the configuration details.

Input Common-Mode and CLKIN Control Register (04h)

Use the Input Common-Mode and CLKIN Control register (04h, Table 17) to enable a self-biased, input common-mode voltage level, and to enable optional internal termination between the differential CLKIN_inputs.

Table 8. Pseudo-Random Data Pattern

SEQUENCE	INITIAL VALUE	FIRST THREE SAMPLES
Short (2 ⁹)	0x0df	0xdf9, 0x353, 0x301
Long (2 ²³)	0x29b80a	0x591, 0xfd7, 0x0a3

Table 9. LVDS Output Driver Level (02h)

BIT 7	BIT 6	BIT 5	BIT 4	BIT 3	BIT 2	BIT 1	BIT 0
LVDS_CM[1:0]		TEST_FRAME_LEVEL[1:0]		TEST_CLKOUT_LEVEL[1:0]		TEST_DATA_LEVEL[1:0]	

Table 10. Test Data (OUT_) Level Programming

TEST_DATA_LEVEL[1:0]		DATA (OUT_) OUTPUT
X	0	Normal data output
0	1	Output low (static)
1	1	Output high (static)

X = Don't care.

Table 11. Test CLKOUT Level Programming

TEST_CLKOUT_LEVEL[1:0]		CLKOUT OUTPUT
X	0	Normal CLKOUT output
0	1	Output low (static)
1	1	Output high (static)

X = Don't care.

Table 12. Test FRAME Level Programming

TEST_FRAME_LEVEL[1:0]		FRAME OUTPUT
X	0	Normal FRAME output
0	1	Output low (static)
1	1	Output high (static)

X = Don't care.

Ultra-Low-Power, Octal, 12-Bit, 50MSPs, 1.8V ADC with Serial LVDS Outputs

The CMI_SELF bit (04h[0]) is used to enable the optional, self-biased input common-mode voltage. By default, CMI_SELF is set to logic 0, disabling this feature. Setting CMI_SELF to logic 1 allows the specified common-mode voltage to be applied to the analog input pins through approximately 2k Ω resistance. The level of the input common-mode voltage is set by the CMI_ADJ[2:0] bits (04h[3:1]). The default setting for CMI_ADJ[2:0] is 100, which corresponds to a CMOUT voltage of 1100mV. The internally supplied and programmed input common-mode voltage is always available on the CMOUT pin. Table 18 contains configuration options, and Figure 2 details the input configuration.

By default, the CLKIN_TERM bit (04h[4]) is set to logic 0, disabling the internal, differential CLKIN input termination resistance. To enable the optional internal differential 100 Ω termination resistance (from CLKIN+ to CLKIN-), set CLKIN_TERM to logic 1 (Figure 4).

Channel Power Management: SHDN0 (05h) and SHDN1 (06h) Registers

The SHDN input allows the ADC to support two individually programmed power states. The Channel Power Management (CPM): SHDN0 register (05h) is used to individually enable or disable each channel for power state 0 (SHDN = 0). The default state of

Table 13. LVDS Output Common-Mode Voltage Adjustment

LVDS_CM[1:0]		LVDS OUTPUT COMMON-MODE VOLTAGE (V)
0	0	1.2 (default)
0	1	1.0
1	0	0.8
1	1	0.6

Table 14. LVDS Output Driver Management (03h)

BIT 7	BIT 6	BIT 5	BIT 4	BIT 3	BIT 2	BIT 1	BIT 0
—	LVDS_TERM[2:0]			LVDS_IADJ[3:0]			

Table 15. LVDS Output Drive Current Configuration

LVDS_IADJ[3:0]				DRIVE CURRENT (mA)
0	0	0	0	3.5 (default)
0	0	0	1	0.5
0	0	1	0	1.0
0	0	1	1	1.5
0	1	0	0	2.0
0	1	0	1	2.5
0	1	1	0	3.0
0	1	1	1	3.5
1	0	0	0	4.0
1	0	0	1	4.5
1	0	1	0	5.0
1	0	1	1	5.5
1	1	0	0	6.0
1	1	0	1	6.5
1	1	1	0	7.0
1	1	1	1	7.5

Table 16. LVDS Output Drive Internal Termination Configuration

LVDS_TERM[2:0]			LVDS INTERNAL TERMINATION (Ω)
0	0	0	Disabled (default)
0	0	1	800
0	1	0	400
0	1	1	267
1	0	0	200
1	0	1	160
1	1	0	133
1	1	1	100

Ultra-Low-Power, Octal, 12-Bit, 50MSPS, 1.8V ADC with Serial LVDS Outputs

CPM: SHDN0 is 1111-1111, which causes power state 0 to enable all eight channels (by default). The CPM: SHDN1 register (06h) is used to enable or disable each channel for power state 1 (SHDN = 1). The default state of CPM: SHDN1 is 0000-0000, which causes power state 1 to disable all eight channels (by default). Both power states are independently configurable for any combination of enabled and disabled channels (Tables 19 and 20).

Custom Test Pattern Registers (07h, 08h, 09h)

The Custom Test Pattern (1, 2, and 3) registers are used to create a user-programmed test pattern sequence (TEST_DATA = 1, TEST_PATTERN[2:0] = 010, see Tables 5 and 7). The data for the custom test pattern sequence is divided among the three Custom Test Pattern registers (Tables 21, 22, and 23). The custom test pattern comprises a series of two, 12-bit sequences (BITS_CUSTOM1[11:0] first, followed by BITS_CUSTOM2[11:0]) that repeat continuously.

Table 17. Input Common Mode and CLKIN Control (04h)

BIT 7	BIT 6	BIT 5	BIT 4	BIT 3	BIT 2	BIT 1	BIT 0
—	—	—	CLKIN_TERM		CMI_ADJ[2:0]		CMI_SELF

Table 18. Input Common-Mode Voltage Configuration

CMI_ADJ[2:0]			INPUT COMMON-MODE VOLTAGE (mV)
0	0	0	1020
0	0	1	1040
0	1	0	1060
0	1	1	1080
1	0	0	1100 (default)
1	0	1	1120
1	1	0	1140
1	1	1	1160

Table 19. Channel Power Management: SHDN0 (05h)

BIT 7	BIT 6	BIT 5	BIT 4	BIT 3	BIT 2	BIT 1	BIT 0
CH8_SHDN0	CH7_SHDN0	CH6_SHDN0	CH5_SHDN0	CH4_SHDN0	CH3_SHDN0	CH2_SHDN0	CH1_SHDN0

Table 20. Channel Power Management: SHDN1 (06h)

BIT 7	BIT 6	BIT 5	BIT 4	BIT 3	BIT 2	BIT 1	BIT 0
CH8_SHDN1	CH7_SHDN1	CH6_SHDN1	CH5_SHDN1	CH4_SHDN1	CH3_SHDN1	CH2_SHDN1	CH1_SHDN1

Table 21. Custom Test Pattern 1 (07h)

BIT 7	BIT 6	BIT 5	BIT 4	BIT 3	BIT 2	BIT 1	BIT 0
BITS_CUSTOM1[7:0]							

Table 22. Custom Test Pattern 2 (08h)

BIT 7	BIT 6	BIT 5	BIT 4	BIT 3	BIT 2	BIT 1	BIT 0
BITS_CUSTOM2[7:0]							

Ultra-Low-Power, Octal, 12-Bit, 50Mpsps, 1.8V ADC with Serial LVDS Outputs

Table 23. Custom Test Pattern 3 (09h)

BIT 7	BIT 6	BIT 5	BIT 4	BIT 3	BIT 2	BIT 1	BIT 0
BITS_CUSTOM2[11:8]				BITS_CUSTOM1[11:8]			

Table 24. Special Function Register (10h) Status Byte (Read)

STATUS BIT NO.	READ VALUE	DESCRIPTION
7	0	Reserved
6	0	Reserved
5	0 or 1	1 = ROM read in progress
4	0 or 1	1 = ROM read completed, and register data is valid (checksum ok)
3	0	Reserved
2	1	Reserved
1	0 or 1	Reserved
0	0 or 1	1 = Duty-cycle equalizer DLL is locked

Reserved Registers (0Ah to 0Fh)

These registers are reserved and should not be used or programmed. It is possible to read from or write to these registers, but the commands have no effect on device operation.

Special Function Register (10h)

The Special Function register has two key functions: software device reset and device status. To initiate a software device reset, write the command 5Ah to the Special Function register. Do not write any other values to this register as they could permanently alter the device configuration. When read, the register returns a status byte with the information described in Table 24.

Applications Information

Analog Inputs

The ADC provides better SFDR and THD with fully differential input signals than a single-ended input drive. In differential input mode, even-order harmonics are lower as both inputs are balanced, and each of the ADC inputs only require half the signal swing compared to single-ended input mode. Single-ended operation for the device is not recommended.

AC-Coupled Inputs

An RF transformer provides an excellent solution for converting a single-ended signal to a fully differential signal (Figure 11). CMOUT provides the common-mode

voltage for an AC-coupled input. The transformer shown has an impedance ratio of 1:1. Alternatively, a different step-up transformer can be selected to reduce the drive requirements. A reduced signal swing from the input driver can also improve the overall distortion.

Clock Inputs

Differential, AC-Coupled Clock Inputs

For optimum dynamic performance, the clock inputs to the device should be driven with an AC-coupled differential signal. However, frequently the available clock source is single-ended. Figure 12 demonstrates one method for converting a single-ended clock signal into a differential signal with a transformer. In this example, a Coilcraft transformer (TTWB-2-B), whose impedance ratio from primary to secondary is 1:2.

The signal in this example is terminated into a series combination of two 50Ω resistors with their common node AC-coupled to ground. Figure 12 illustrates the secondary side of the transformer to be coupled directly to the clock inputs. Since the clock inputs are self-biasing, the center tap of the transformer must be AC-coupled to ground or left unconnected. If the center tap of the transformer's secondary side is DC-coupled to ground, it is necessary to add blocking capacitors in series with the clock inputs.

Clock jitter performance can be enhanced if the clock signal has a high slew rate at the time of its zero-crossing. Therefore, if a sinusoidal source is used to drive the clock inputs, the clock amplitude should be as large as possible to maximize the zero-crossing slew rate. The back-to-back Schottky diodes shown in Figure 12 are not required as long as the input signal is held to a differential voltage potential of 3V_{P-P} or less. If a larger amplitude signal is provided (to maximize the zero-crossing slew rate), then the diodes serve to limit the differential signal swing at the clock inputs.

Any differential mode noise coupled to the clock inputs translates to clock jitter and degrades the SNR performance of the device. Any differential mode coupling of the analog input signal into the clock inputs results in harmonic distortion. Consequently, it is important that the clock lines be well isolated from the analog signal input and from the digital outputs.

Ultra-Low-Power, Octal, 12-Bit, 50Mps, 1.8V ADC with Serial LVDS Outputs

MAX19527

Singe-Ended, AC-Coupled Clock Inputs

In single-ended operation, the clock signal is applied to the device's positive clock input (CLK+) through a buffer amplifier (Fairchild NC7WV04P6X). The negative input (CLK-) is connected to ground in this mode. In single-ended clock configuration, an external 10kΩ potentiometer

can be utilized to control the duty cycle of the clock input signal. Measure the clock input to the device after the buffer and adjust the potentiometer until the desired duty cycle is achieved. The circuit in Figure 13 allows for duty-cycle adjustments between 20% and 80%.

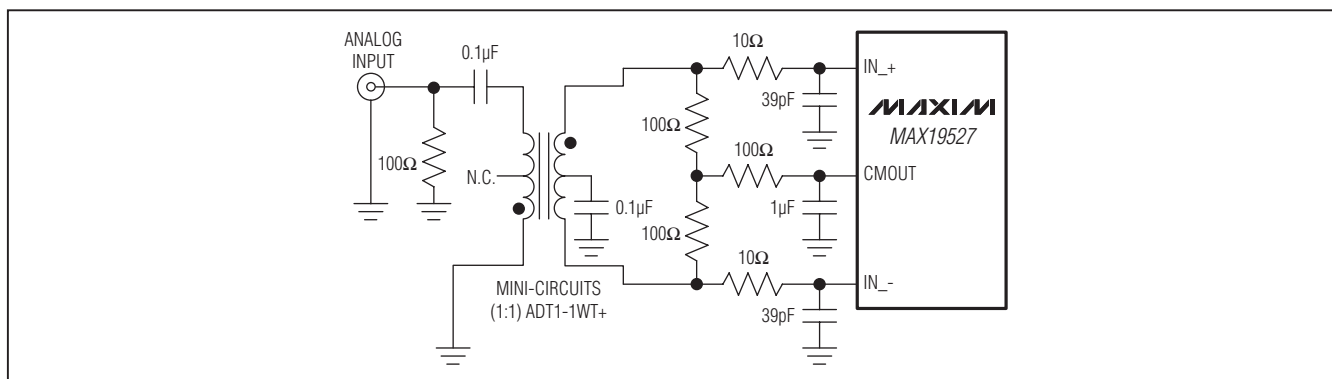

Figure 11. Transformer-Coupled Input Drive

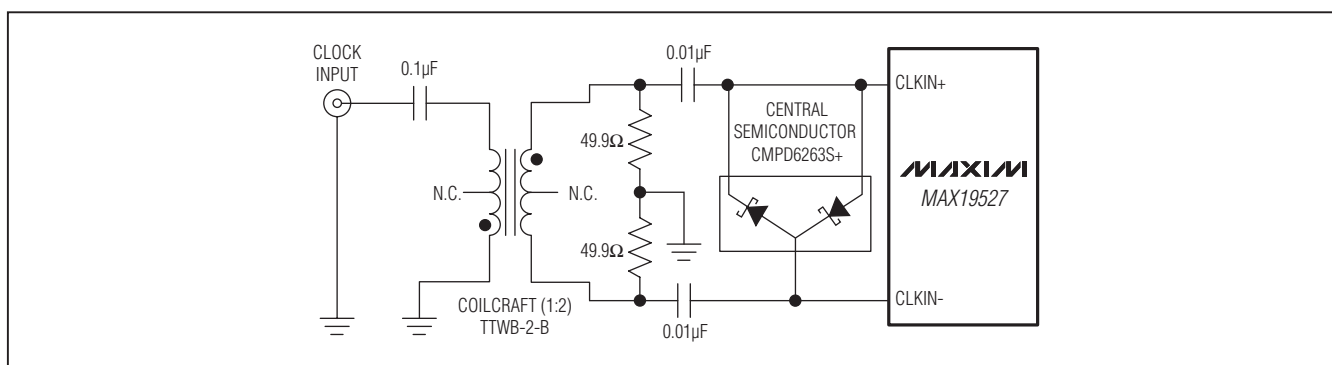

Figure 12. Single-Ended-to-Differential Clock Input

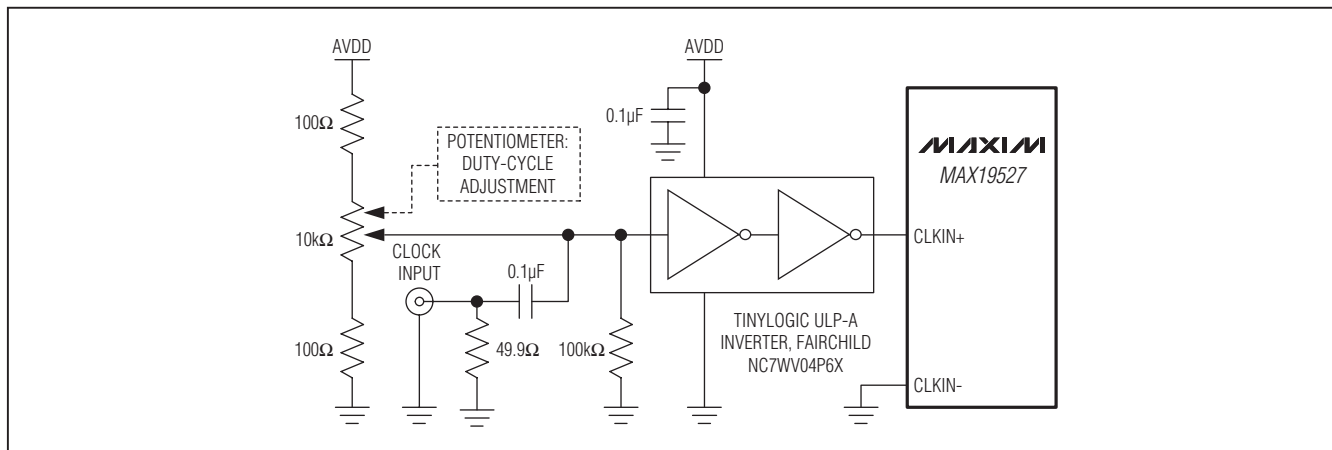

Figure 13. Single-Ended Clock Input with Duty-Cycle Adjustment

Ultra-Low-Power, Octal, 12-Bit, 50Mps, 1.8V ADC with Serial LVDS Outputs

Grounding, Bypassing, and Board Layout

The ADC requires high-speed board layout design techniques to achieve optimal dynamic performance. Refer to the MAX19527 EV kit data sheet for a board layout reference. Locate all bypass capacitors as close as possible to the device, preferably on the same side as the ADC, using surface-mount components for minimum inductance. Bypass the AVDD and OVDD inputs with a separate 0.1µF ceramic capacitor to GND at both sides of the device (row A and row M). Bypass CMOUT with a 1µF ceramic capacitor to GND. To use the internal reference, bypass REFIO with a 0.1µF ceramic capacitor to GND. For optimal performance using either an internal or external reference, bypass REFH to REHL with a 0.1µF ceramic capacitor.

Multilayer boards with ample ground and power planes produce the highest level of signal integrity. Isolate the ground plane from any noisy digital system ground planes. Route high-speed digital signal traces away from sensitive analog traces. Keep all signal lines short and free of 90° turns.

Ensure that the differential analog input network layout is symmetric and that all parasitics are balanced equally. Ensure that the LVDS outputs are routed as matched length, 100Ω terminated, differential transmission lines. Refer to the MAX19527 EV kit data sheet for an example of symmetric input layout.

Parameter Definitions

Integral Nonlinearity (INL)

INL is the deviation of the measured transfer function from a best-fit straight line. Worst-case deviation is defined as INL.

Differential Nonlinearity (DNL)

DNL is the difference between the measured transfer-function step width and the ideal value of 1 LSB. A DNL error specification of less than 1 LSB guarantees no missing codes and a monotonic transfer function. DNL deviations are measured at each step of the transfer function and the worst-case deviation is defined as DNL.

Offset Error

Offset error is a parameter that indicates how well the actual transfer function matches the ideal transfer function at midscale. Ideally, the midscale transition occurs at 0.5 LSB above midscale. The offset error is the amount of deviation between the measured midscale transition point and the ideal midscale transition point.

Gain Error

Gain error is a figure of merit that indicates how well the slope of the measured transfer function matches the slope of the ideal transfer function based on the specified full-scale input voltage range. The gain error is defined as the relative error of the measured transfer function and is expressed as a percentage.

Small-Signal Noise Floor (SSNF)

SSNF is the integrated noise and distortion power in the Nyquist band for small-signal inputs. The DC offset is excluded from this noise calculation. For this converter, a small signal is defined as a single tone with an amplitude less than -35dBFS. This parameter captures the thermal and quantization noise characteristics of the converter and can be used to help calculate the overall noise figure of a receive channel.

Near-Carrier Signal-to-Noise Ratio (NCSNR)

Near-carrier SNR is defined as the ratio of the power in a near full-scale sinusoidal signal to the noise power measured at 1kHz offset from the signal. The noise power is normalized to 1Hz bandwidth. The near-carrier noise measured in a single ADC channel can be correlated to the near-carrier noise in other channels in a multichannel ADC. If that is the case, if output signals from multiple channels are summed, the addition process does not provide full processing gain of $10 \times \log(N)$, where N is the number of channels. Near-carrier SNR for an 8-channel coherent sum is defined for the case of applying an in-phase sinusoidal signal to all 8 ADC channels, and computing the near-carrier SNR for the digital sum of all eight outputs.

Signal-to-Noise Ratio (SNR)

For a waveform perfectly reconstructed from digital samples, the theoretical maximum SNR is the ratio of the full-scale analog input (RMS value) to the RMS quantization error (residual error). The ideal, theoretical minimum analog-to-digital noise is caused by quantization error only and results directly from the ADC's resolution (N bits):

$$\text{SNR}_{\text{dB}}[\text{MAX}] = 6.02\text{dB} \times N + 1.76\text{dB}$$

In reality, there are other noise sources besides quantization noise (e.g., thermal noise, reference noise, clock jitter, etc.). SNR is computed by taking the ratio of the RMS signal to the RMS noise. RMS noise includes all spectral components to the Nyquist frequency excluding the fundamental, the first six harmonics (HD2–HD7), and the DC offset.

$$\text{SNR} = 20 \times \log \left(\frac{\text{SIGNAL}_{\text{RMS}}}{\text{NOISE}_{\text{RMS}}} \right)$$

Ultra-Low-Power, Octal, 12-Bit, 50MSPs, 1.8V ADC with Serial LVDS Outputs

Signal-to-Noise and Distortion (SINAD)

SINAD is computed by taking the ratio of the RMS signal to the RMS noise plus the RMS distortion. RMS noise includes all spectral components to the Nyquist frequency excluding the fundamental, the first six harmonics (HD2–HD7), and the DC offset. RMS distortion includes the first six harmonics (HD2–HD7).

$$\text{SNR} = 20 \times \log \left(\frac{\text{SIGNAL}_{\text{RMS}}}{\sqrt{\text{NOISE}_{\text{RMS}}^2 + \text{DISTORTION}_{\text{RMS}}^2}} \right)$$

Single-Tone Spurious-Free Dynamic Range (SFDR)

SFDR is the ratio expressed in decibels of the RMS amplitude of the fundamental (maximum signal component) to the RMS amplitude of the next largest spurious component, excluding DC offset.

Total Harmonic Distortion (THD)

THD is the ratio of the RMS of the first six harmonics of the input signal to the fundamental itself. This is expressed as:

$$\text{THD} = 20 \times \log \left(\frac{\sqrt{V_2^2 + V_3^2 + V_4^2 + V_5^2 + V_6^2 + V_7^2}}{V_1} \right)$$

V_1 is the fundamental amplitude and V_2 – V_7 are the amplitudes of the 2nd-order through 7th-order harmonics (HD2–HD7).

Intermodulation Distortion (IMD)

IMD is the ratio of the RMS sum of the intermodulation products to the RMS sum of the two fundamental input tones. This is expressed as:

$$\text{IMD} = 20 \times \log \left(\frac{\sqrt{V_{\text{IM}1}^2 + V_{\text{IM}2}^2 + \dots + V_{\text{IM}13}^2 + V_{\text{IM}14}^2}}{\sqrt{V_1^2 + V_2^2}} \right)$$

V_1 and V_2 are amplitudes of the two fundamental inputs, and $V_{\text{IM}n}$ is the amplitude of the n th intermodulation product. The fundamental input tone amplitudes (V_1 and V_2) are at -6.5dBFS. Fourteen intermodulation products ($V_{\text{IM}n}$) are used in the ADC IMD calculation. The intermodulation products are the amplitudes of the output spectrum at the following frequencies, where $f_{\text{IN}1}$ and $f_{\text{IN}2}$ are the fundamental input tone frequencies:

- Second-order intermodulation products:
 $f_{\text{IN}1} + f_{\text{IN}2}, f_{\text{IN}2} - f_{\text{IN}1}$
- Third-order intermodulation products:
 $2 \times f_{\text{IN}1} - f_{\text{IN}2}, 2 \times f_{\text{IN}2} - f_{\text{IN}1},$
 $2 \times f_{\text{IN}1} + f_{\text{IN}2}, 2 \times f_{\text{IN}2} + f_{\text{IN}1}$
- Fourth-order intermodulation products:
 $3 \times f_{\text{IN}1} - f_{\text{IN}2}, 3 \times f_{\text{IN}2} - f_{\text{IN}1},$
 $3 \times f_{\text{IN}1} + f_{\text{IN}2}, 3 \times f_{\text{IN}2} + f_{\text{IN}1}$
- Fifth-order intermodulation products:
 $3 \times f_{\text{IN}1} - 2 \times f_{\text{IN}2}, 3 \times f_{\text{IN}2} - 2 \times f_{\text{IN}1},$
 $3 \times f_{\text{IN}1} + 2 \times f_{\text{IN}2}, 3 \times f_{\text{IN}2} + 2 \times f_{\text{IN}1}$

Overdrive Recovery Time

Overdrive recovery time is the time required for the ADC to recover from an input transient that exceeds the full-scale limits. The specified overdrive recovery time is measured with an input carrier that exceeds the full-scale limits by 6dBFS.

Package Information

For the latest package outline information and land patterns, go to www.maxim-ic.com/packages. Note that a “+”, “#”, or “-” in the package code indicates RoHS status only. Package drawings may show a different suffix character, but the drawing pertains to the package regardless of RoHS status.

PACKAGE TYPE	PACKAGE CODE	OUTLINE NO.
144 CTBGA	X14400-3	21-0492

Ultra-Low-Power, Octal, 12-Bit, 50Msps, 1.8V ADC with Serial LVDS Outputs

Revision History

REVISION NUMBER	REVISION DATE	DESCRIPTION	PAGES CHANGED
0	6/10	Initial release	—

Maxim cannot assume responsibility for use of any circuitry other than circuitry entirely embodied in a Maxim product. No circuit patent licenses are implied. Maxim reserves the right to change the circuitry and specifications without notice at any time.

30 _____ **Maxim Integrated Products, 120 San Gabriel Drive, Sunnyvale, CA 94086 408-737-7600**