

Dimmable Light Ballast with Power Factor Correction

Designer Reference Manual

M68HC08
Microcontrollers

DRM067
Rev. 1
12/2005

freescale.com

Dimmable Light Ballast with Power Factor Correction

Designer Reference Manual

by: Petr Frgal
Freescale Czech Systems Center
Roznov pod Radhostem, Czech Republic

To provide the most up-to-date information, the revision of our documents on the World Wide Web will be the most current. Your printed copy may be an earlier revision. To verify that you have the latest information available, refer to <http://www.freescale.com>

Contents

Chapter 1 Introduction

1.1	Introduction	7
1.2	Benefits of this Solution	7
1.3	The MC68HC908LB8 Microcontroller	8

Chapter 2 Control Theory

2.1	Introduction	11
2.1.1	Fluorescent Lamp Control Theory	11
2.1.2	Fluorescent Lamp Operation	11
2.1.3	Controlling the Fluorescent Lamp	13
2.2	PFC Control Theory	15
2.2.1	Introduction	15
2.2.2	Digital Power Factor Concept — Hysteresis Current Control Mode	16
2.2.3	Digital Power Factor Concept — Discontinuous Conduction Mode	17
2.2.4	Concept Summary	19

Chapter 3 Reference Design

3.1	Application Outline	21
3.2	Dimmable Light Ballast Characteristics	21
3.3	Application Description	22
3.3.1	Light Ballast Control	23
3.3.2	Power Factor Correction	23
3.3.3	Protection Features	24
3.4	Software Specification	24
3.5	Hardware Specification	24

Chapter 4 Hardware Design

4.1	Hardware Implementation	25
4.2	System Modules	25
4.2.1	Input and PFC	26
4.2.2	Inverter	28
4.2.3	Microcontroller	30
4.2.4	Power Supply	33

Chapter 5 Software Design

5.1	Introduction	35
5.2	Control Algorithm Description	35
5.2.1	Power Factor Correction Control	36
5.2.1.1	DC-bus Voltage Control	36
5.2.1.2	Phase Shift Synchronization	36
5.2.1.3	Reference Sine Wave Generation	36
5.2.1.4	Generation of Output PFC Control Signal	36
5.2.2	Light Ballast Control	37
5.2.2.1	Tube Start Mode	37
5.2.2.2	Luminance Level Control (Tube Run Mode)	37
5.3	Software Implementation	39
5.3.1	Initialization Setup	39
5.3.1.1	PWM Setup	40
5.3.1.2	HRP Setup	41
5.3.2	Main Program Loop	42
5.3.3	Synchronization Interrupt Routine	43
5.3.4	Sine Wave Generation Interrupt Routine	43
5.3.4.1	Fault Detection and Processing	45
5.4	Detailed Software Description	46
5.5	Microcontroller Usage	51
5.5.1	Microcontroller Peripheral Usage	51
5.5.1.1	High Resolution PWM (HRP)	51
5.5.1.2	Pulse-Width Modulator (PWM)	51
5.5.1.3	Comparator Module (CM)	51
5.5.1.4	Timer Interface Module (TIM)	51
5.5.1.5	External Interrupt (IRQ)	51
5.5.2	Program and Data Memory Usage	51
5.5.3	I/O Usage	52
5.6	Definitions of Constants and Variables	52
5.6.1	System Setup Definitions	53
5.6.2	System Constants and Variables	55

Chapter 6 Demo Setup

6.1	Hardware Setup	57
6.2	Software Setup	57
6.2.1	Required Software Tools	57
6.2.2	Building and Uploading the Application	57
6.2.3	Executing the Application	58
6.2.4	Project Files	58

Appendix A. Schematics and Part List

A.1	Schematics	59
A.2	Parts List	66

Appendix B. References

Chapter 1

Introduction

1.1 Introduction

This reference design describes the design of a fully digital dimmable light ballast with power factor correction (PFC) control for two parallel connected fluorescent lamps.

This reference design focuses on the lamp ballast hardware and software implementation using the Freescale MC68HC908LB8 microcontroller (MCU), which is designed specifically for light ballast applications. This MCU includes a set of peripherals that are appropriate for light dimming and power factor correction.

The reference design incorporates both hardware and software parts of the system including detailed hardware descriptions and full software listings. The application uses half-bridge topology, typical for this kind of applications. The MC68HC908LB8 MCU is well suited to this topology.



Figure 1-1. Dimmable Light Ballast with PFC Demo

1.2 Benefits of this Solution

Microcontrollers offer the advantages of low cost and attractive digital light ballast design. Using a dedicated on-chip high resolution PWM (HRP) allows easy implementation of dimming features. PFC improves the efficiency of the light ballast. Harmonic content of the input current for the mains supplied equipment meets the European regulation EN 61000-3-2 and the international standard IEC 1000-3-2.

The advantages of the presented digital solution over standard analog solutions can be summarized as follows:

Introduction

- Energy saving
- Ease of adapting software for different lamps
- Ease of re-programming the system behavior
- Software can simplify the hardware
- Diagnostic functions — fault state, tube end-of-life, ignition fault, tube removed
- Open to innovation

The MC68HC908LB8 is designed for light ballast applications. It contains a HRP that is assigned to control a lamp ballast circuit using half-bridge topology. The HRP provides two complementary outputs for controlling a half-bridge drive. Pulse Width Modulation (PWM) with constant duty cycle is used for light ballast control. The HRP frequency can be adjusted easily by software in range 40 kHz to 120 kHz in 256 steps. Dimming levels down to 5% are possible.

The PFC circuit uses an on-chip comparator on the MC68HC908LB8. This peripheral simplifies the dimming light ballast solution with PFC, since it eliminates the need of external components and thus decreases the system cost.

The reference design is intended for all geographic regions, so 110V/60Hz and 230V/50Hz input voltage supplies are supported.

The application can be debugged using the MON08 CYCLONE debug tool in monitor mode.

WARNING

Since the application runs at high voltage, it is dangerous to connect development tools directly to the board. Therefore, it is recommended to use an opto-isolation monitor mode board. This separate board provides an opto-isolated interface for the MON08 debug tool, using the MON08 standard connector. This allows the user to safely debug or examine code in-circuit.

1.3 The MC68HC908LB8 Microcontroller

The MC68HC908LB8 is a member of the low-cost, high performance MC68HC08 Family of 8-bit MCUs. All MCUs in the family use the enhanced MC68HC08 central processor unit (CPU08) and are available with a variety of modules, memory sizes and types, and package types.

Standard features of microcontroller MC68HC908LB8 are:

- 8 MHz internal bus frequency
- Trimmable internal oscillator:
 - 4.0 MHz internal bus operation
 - 8-bit trim capability
 - 25% untrimmed
 - 2% trimmed
- 8K bytes of 10K write/erase cycle typical on-chip in application programmable FLASH⁽¹⁾ memory with security option
- 128 bytes of on-chip random access memory (RAM)

1. Non volatile memory that retains its data when the power is removed.

- Dual channel high resolution PWM (HRP) with deadtime insertion and shutdown input to perform light control and dimming functions for ballasts. The outputs use frequency dithering to achieve a 3.9 ns output resolution.
- Dual channel pulse width modulator module to provide power factor correction capability
- 7-channel, 8-bit successive approximation analog-to-digital converter (ADC)
- Comparator for power factor correction capability or for general-purpose use
- 7-bit keyboard interrupt
- One 16-bit, 2-channel timer interface module with one output available on port pin (PTA6) for input capture and PWM
- 17 general-purpose input/output (I/O) pins and one input-only pin
 - Three shared with HRP module
 - Three shared with PWM module
 - Three shared with comparator
 - Seven shared with ADC module (AD[0:6])
 - One shared with timer channel 0
 - Two shared with OSC1 and OSC2
 - One shared with reset
 - Seven shared with keyboard interrupt
 - One input-only pin shared with external interrupt (IRQ)
- Available packages:
 - 20-pin small outline integrated chip (SOIC) package
 - 20-pin plastic dual in-line package (PDIP)
- On-chip programming firmware for use with host personal computer which does not require high voltage for entry
- System protection features:
 - Optional computer operating properly (COP) reset
 - Low-voltage reset
 - Illegal opcode detection with reset
 - Illegal address detection with reset
- Low-power design; fully static with stop and wait modes
- Standard low-power modes of operation:
 - Wait mode
 - Stop mode
- Master reset pin and power-on reset (POR)
- 674 bytes of FLASH programming routines in read-only memory (ROM)
- Break module (BRK) to allow single breakpoint setting during in-circuit debugging
- Internal pullup on RST pin to reduce customer system cost
- Selectable pullups on ports A and C
 - Selection on an individual port bit basis
 - During output mode, pullups are disengaged
- High current 10 mA sink / 10 mA source capability on all port pins

Chapter 2

Control Theory

2.1 Introduction

This chapter covers fluorescent lamp theory and two PFC concepts - discontinuous conduction mode and hysteresis current control mode.

2.1.1 Fluorescent Lamp Control Theory

To light a low-pressure fluorescent lamp, the electronic circuit must perform the following four main functions:

- Provide a startup voltage across the electrodes of the lamp
- Maintain a constant current when the lamp is operating in the steady state
- Ensure that the circuit will remain stable, even under fault conditions
- Comply with the applicable domestic and international regulations (PFC, THD and safety)

Most generally, light ballast topology fairly closely matches target lamps in terms of tube wattage, length, and diameter. The digital electronic lamp ballast includes also additional features like dimming capability, tube end-of-life, startup fault, tube removed indication, and so on. Different tubes require different software settings; also, some hardware components may have to be adapted accordingly.

2.1.2 Fluorescent Lamp Operation

When the lamp is off, no current flows through the tubes, and the apparent impedance is nearly infinite. When the voltage across the electrodes reaches the V_{strike} value, the gas mixture is highly ionized and an arc is generated across the two terminals of the lamp. This behavior is depicted by the typical operating curve shown in [Figure 2-1](#).

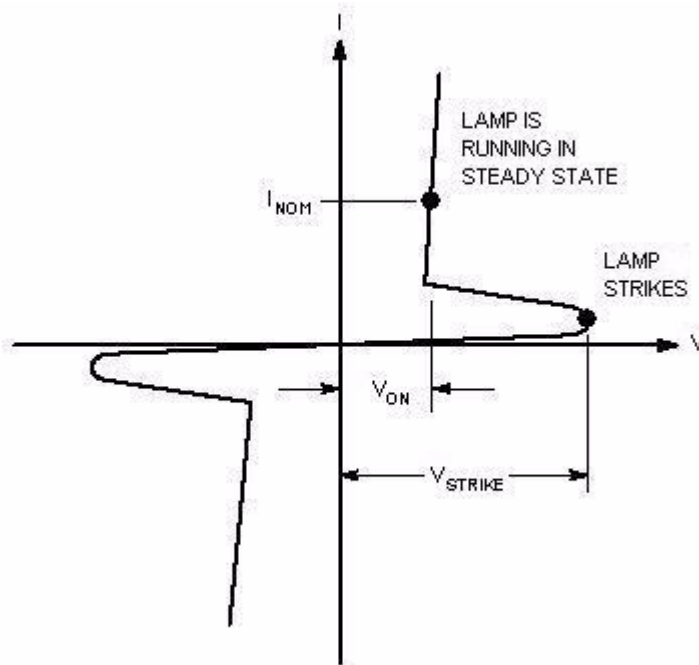

Figure 2-1. Typical Low Pressure Fluorescent Tube I/V Characteristic

The value of V_{strike} is a function of several parameters:

- Gas filling mixture
- Gas pressure and temperature
- Tube length
- Tube diameter
- Temperature of electrodes: cold or hot

Typically, values of V_{strike} are in range 500 V to 1200 V. Once the tube is on, the voltage across it drops to the on-state voltage (V_{on}), the magnitude of this voltage being dependent upon the characteristics of the tube. Typically, V_{on} is in range 40 V to 110 V.

The value of V_{on} will vary during the operation of the lamp but, in order to simplify the analysis, we will assume, as a first approximation, that the on-state voltage is constant when the tube is running in steady state.

Consequently, the equivalent steady state circuit can be described by two back-to-back Zener diodes as shown in [Figure 2-2](#). The startup network is far more complex, particularly during ionization of the gas. This is a consequence of the negative impedance exhibited by the lamp when the voltage across its electrodes collapses from V_{strike} to V_{on} .

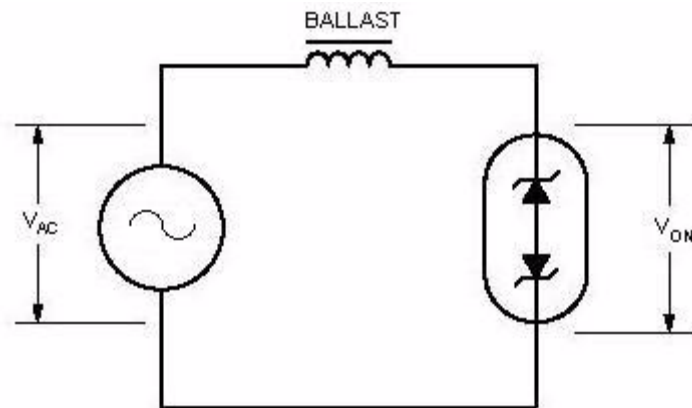

Figure 2-2. Typical Fluorescent Tube Equivalent Circuit in Steady State

Up to now, there is no model available to describe the start up sequence of these lamps. However, since most of the phenomena are dependent upon the steady state characteristics of the lamp, one can simplify the analysis by assuming that the passive networks control the electrical behavior of the circuit. This assumption is wrong during the time elapsed from V_{strike} to V_{on} , but since this time interval is very short, the results given by the proposed simple model are accurate enough to design the converter. When a fluorescent tube is aging, its electrical characteristics degrade from the original values, yielding less light for the same input power, and different V_{strike} and V_{on} voltages. A simple, low-cost electronic lamp ballast cannot optimize the overall efficiency throughout the lifetime of the tube, but the circuit must be designed to guarantee the operation of the lamp even under worst case “end of life” conditions. As a consequence, the converter will be slightly oversized to make sure that, after 8000 hours of operation, the system will still drive the fluorescent tube.

2.1.3 Controlling the Fluorescent Lamp

As already stated, both the voltage and the current must be accurately controlled to make sure that a given fluorescent lamp operates within its specifications.

The most commonly used network is built around a large inductor, connected in series with the lamp, and associated with a bimetallic switch generally named “the starter”. [Figure 2-3](#) gives the typical electrical schematic diagram for the standard, line operated, fluorescent tube control.

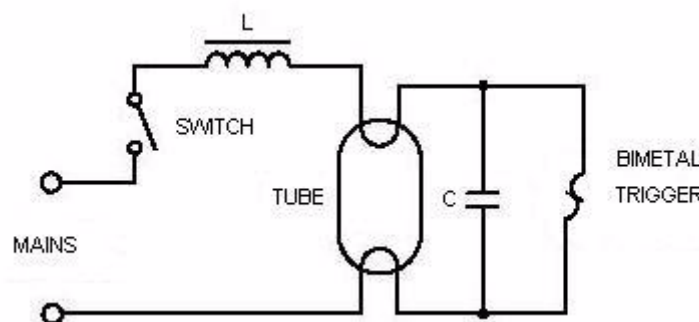

Figure 2-3. Standard Ballast Circuit for Fluorescent Tube

Control Theory

The operation of a fluorescent tube requires several components around the tube, as shown in [Figure 2-3](#). The gas mixture enclosed in the tube is ionized by means of a high voltage pulse applied between the two electrodes.

To make this startup easy, the electrodes are actually made of filaments that are heated during the tube ionization startup (i.e. increasing the electron emission), their disconnection being automatic when the tube goes into the steady state mode. At this time, the tube impedance decreases toward its minimum value (depending upon the tube internal characteristics), the current in the circuit being limited by the inductance L in series with the power line. The starting element, commonly named “starter”, is an essential part to ignite the fluorescent tube. It is made of a bimetallic contact, enclosed in a glass envelope filled with a neon based gas mixture, and is normally in the OPEN state. When the line voltage is applied to the circuit, the fluorescent tube exhibits a high impedance, allowing the voltage across the “starter” to be high enough to ionize the neon mixture. The bimetallic contact gets hot, turning ON the contacts which, in turn, will immediately de-ionize the “starter”. Therefore, the current can flow in the circuit, heating up the two filaments. When the bimetallic contact cools down, the electrical circuit is rapidly opened, giving a current variation in the inductance L which, in turn, generates an over-voltage according to Lenz’s law.

Since there is no synchronization with the line frequency (the switch operates on a random basis), the circuit opens at a current level anywhere between maximum and zero.

If the voltage pulse is too low, the tube does not turn on, and the startup sequence is automatically repeated until the fluorescent tube ionizes. At that time, the tube impedance falls to its minimum value, yielding a low voltage drop across its end electrodes and, hence, across the switch. Since the starter can no longer be ionized, the electrical network of the filaments remains open until the next turning on of the circuit.

We must point out that the fluorescent tube turns off when the current is zero; this is the source of the 50 Hz flickering in a standard circuit. This is an important problem, which can lead to visual problems due to the stroboscopic effect on any rotating machines or computer terminals.

To take care of this phenomena, the fluorescent tubes, at least those used in industrial plants, are always set on a dual basis in a single light spreader, and are fed from two different phases (real or virtual via a capacitor) in order to eliminate the flickering.

On the other hand, the magnetic ballast provides a very low cost solution for driving a low pressure fluorescent tube. To overcome the flickering phenomenon and the poor startup behavior, the engineers have endeavored to design electronic circuits to control the lamp operation at a much higher frequency. The efficiency (P_{in}/Lux) of the fluorescent lamp increases significantly, as soon as the current through the lamp runs above a few kilo Hertz.

The electronic circuits that can be used to build a fluorescent lamp controller can be divided into two main groups:

- Single switch topology, with unipolar AC current, (unless the circuit operates in the parallel resonant mode)
- Dual switch circuit, with a bipolar AC output current

Manufacturers of fluorescent lamps usually recommend operating the tubes with a bipolar AC current. This avoids constantly biasing the electrodes as an anode-cathode pair, which, in turn, decreases the expected lifetime of the lamp. In fact, when a unipolar AC current flows into the tube, the electrodes behave like a diode and the material of the cathode side is absorbed by the electron flow, yielding a rapid wear out of the filaments. As a consequence, all of the line operated electronic lamp ballasts are designed with either a dual switch circuit (the only one used in Europe), or a single switch, parallel resonant configuration (mainly used in countries with 110 V lines), providing an AC current to the tubes. A few low

power, battery operated fluorescent tubes are driven with a single switch fly-back topology, but, the output transformer is coupled to the tube by a capacitive network and the current through the lamp is alternating current. However, the filaments (if any) cannot be automatically turned off by this simple configuration and the global efficiency is downgraded accordingly.

Dual switch circuits are divided into two main topologies:

- Half-bridge, series resonant
- Current fed push-pull converter

The half-bridge is, by far, the most widely used in Europe (100% of the so-called “energy saving” lamps and industrial applications are based on this topology), while the push-pull is the preferred solution in the USA with around 80% of the electronic lamp ballasts using this scheme today.

Both of these topologies have their advantages and drawbacks, the consequence for the associated power transistors being not at all negligible, as shown by [Table 2-1](#). The half-bridge topology controlled by the dedicated MC68HC908LB8 MCU is implemented in [Chapter 3](#). For more details about electronic lamp ballast theory see Reference [1].

Table 2-1. Main Characteristics of the Dual Switch Topologies

Parameters	Half-bridge	Push-pull
V(BR)CER	700 V ⁽¹⁾	1100 - 1600 V ⁽¹⁾
Inrush Current	3 to 4 times I nom ⁽²⁾	2 to 3 times I nom ⁽²⁾
tsi window	2.6 – 3.6 μs	1.9 – 2.3 μs
Drive	High and Low side	Low side only
Intrinsic Galvanic Isolation	no	yes

NOTES:

1. These numbers are typical for operation on a 230 V supply.
2. I nom is the current into the transistors in steady state.

2.2 PFC Control Theory

2.2.1 Introduction

The most practical electronic systems contain a conventional single-phase full-bridge rectifier and an input filter capacitor. It is well known that this type of circuit draws high current peaks from the power line and produces a high level of harmonics. High total harmonic distortion (THD) and low power factor therefore reduce the maximum power available from the mains and the efficiency of the electricity supply networks. The European Normative EN 61000-3-2 defines the limits of the harmonic content of the input current for mains supplied equipment. To meet the norms, new designs require an active PFC at the input.

Many specific integrated circuit devices (ICs) are available on the market to perform power factor correction. This approach requires additional electronic components, which increases the system cost and complexity. On the other hand, there is a way to implement PFC control using the MCU, in addition to the MCU’s main control tasks, such as motor control. Digital PFC allows missing out these specific ICs, thereby reducing the system cost. Another benefit of the software implementation is the potential for easy modifications without changing the hardware.

Two power factor correction approaches were implemented in this design, discontinuous conduction mode and hysteresis current control mode. Each of these topologies has advantages and drawbacks. Both topologies are described in the following.

2.2.2 Digital Power Factor Concept — Hysteresis Current Control Mode

The control technique is based on hysteretic current control. The system operates in continuous conduction mode with variable switching frequency (30–100 kHz) (see [Figure 2-5](#)).

This PFC concept is designed to have the minimum of MCU performance requirements. The basic principles of the scheme are depicted in [Figure 2-4](#). The PFC control algorithm includes two control loops, a fast one for input current control and a slow one for output voltage control. The output voltage controller is implemented digitally using the MCU. A value proportional to the required input current is modulated by the PWM and is taken as an input to the current control loop, which is realized by the analogue comparator. The comparator switches the MOSFET in order to maintain the required current value.

The desired shape of the input current is a sine wave. The generated current waveform is shown in [Figure 2-8](#).

A hysteresis current control mode PFC concept has several drawbacks, including variable MOSFET switching frequency, non sinusoidal input current waveform and switching under current, which causes higher losses than other PFC topologies.

The input current harmonics content, however, complies with EN 61000-3-2 standard.

The advantages are simple control circuit, low MCU resources consumption, continuous conduction mode operation, and low total harmonic distortion (THD).

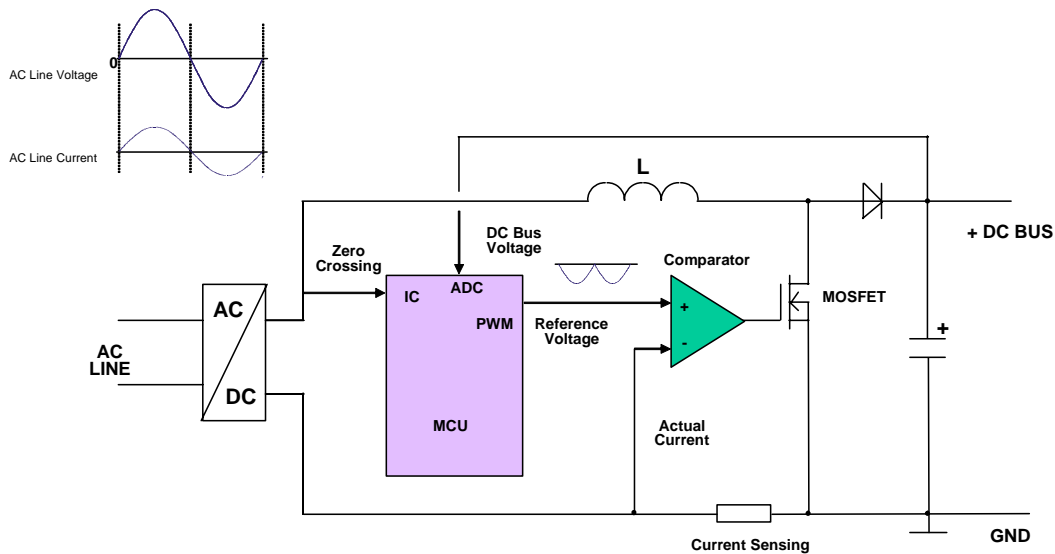

Figure 2-4. Hysteresis Current Control Mode Principle

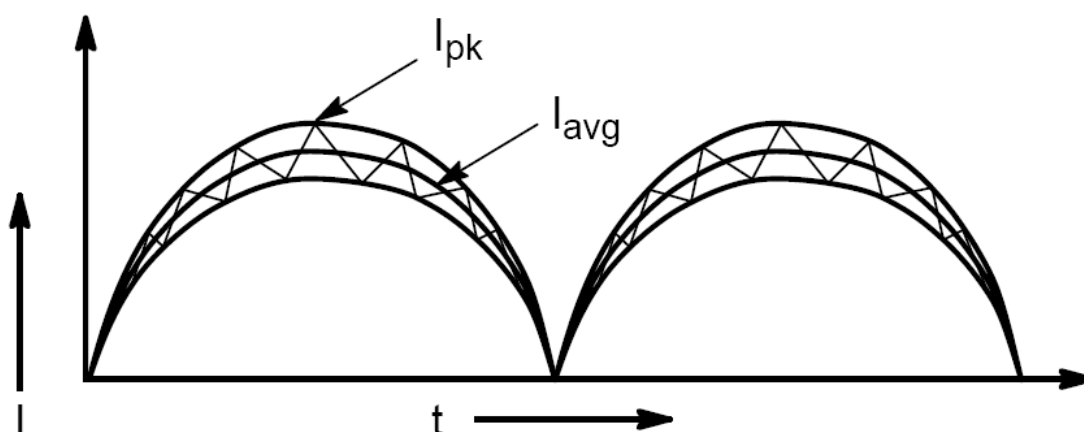

Figure 2-5. Hysteresis Current Control Mode Current Waveform

2.2.3 Digital Power Factor Concept — Discontinuous Conduction Mode

The control technique is based on discontinuous conduction mode with a current loop with a constant switching frequency (40 kHz) (see [Figure 2-7](#)).

The basic principles of the scheme are depicted in [Figure 2-6](#). The PFC control algorithm includes two control loops, the same as the previous approach. The output voltage controller is implemented digitally using the MCU. A value proportional to the required input current is modulated by the PWM0 and is taken as an input to the current control loop, which is realized by the analog comparator. The comparator output is connected to the PWM fault pin that disables the PWM output. PWM1 is used directly for switching the MOSFET in order to maintain the required current value. PWM1 is switched off in every period where the reference sine wave signal generated by PWM0 is higher than the actual current sensed signal on the shunt resistor.

The desired shape of the input current is a sine wave. The generated current waveform is shown in [Figure 2-8](#).

The discontinuous conduction mode PFC concept has several drawbacks — higher THD than hysteresis current control mode, non sinusoidal input current waveform, and the discontinuous conduction mode itself. The input current harmonics content, however, complies with EN 61000-3-2 standard.

The advantages are a simple control circuit, with low MCU resource consumption, and low losses.

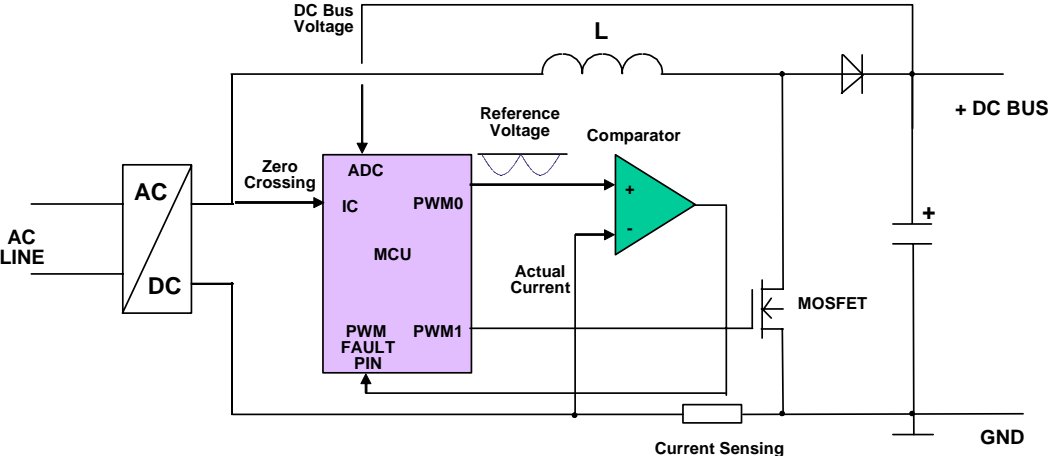

Figure 2-6. Discontinuous Conduction Mode Principle

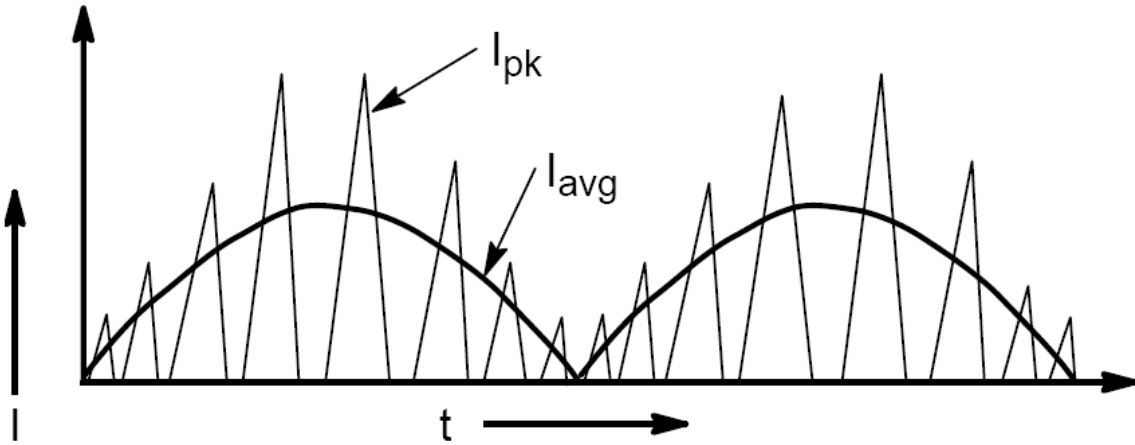

Figure 2-7. Discontinuous Conduction Mode Current Waveform

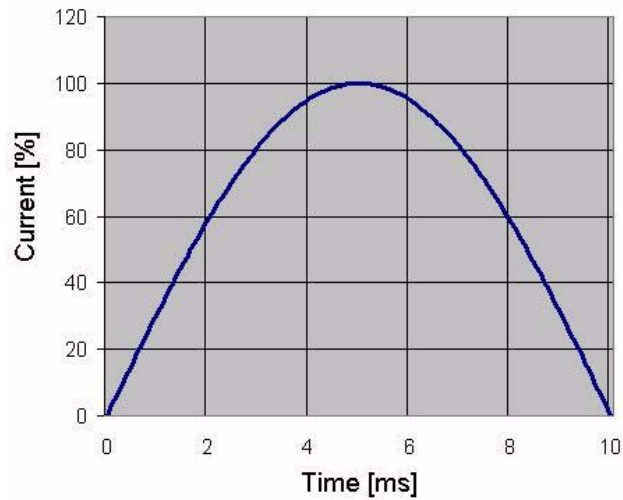

Figure 2-8. Generated Input Current Waveform

2.2.4 Concept Summary

Both the PFC solutions can be used for applications that do not require a large portion of the MCU's resources, because they consume only a fraction of the MCU performance. Compared to a dedicated IC solution, digital PFC offers high flexibility and cost reduction in the overall design, as the PFC function can be provided within the MCU capability of the main application. Digital PFC also provides additional benefits such as a wide range of input voltages (85 V to 265 V AC) at a constant output DC voltage.

However, hysteresis current control mode is more suitable for power above 100W, and discontinuous conduction mode for low power consumption.

Chapter 3

Reference Design

3.1 Application Outline

The presented system is designed to control two parallel connected fluorescent lamps. The reference design meets the following performance specification:

- Single board solution with MC68HC908LB8 microcontroller
- Supported power supply: 110V/60Hz and 230V/50Hz
- Low THD
- High power factor achieved using the PFC circuit
- Control techniques incorporating:
 - Preheating
 - Strike
 - Run mode
- User interface (dimming level potentiometer, monitor mode interface)
- Flickering effect removal
- Lamp aging recognition
- Fault detection
 - DC-bus under-voltage detection (software)
 - DC-bus over-voltage detection (software)
 - Ignition fault (software)
 - Zero current fault (software)

3.2 Dimmable Light Ballast Characteristics

[Table 3-1](#) provides the basic characteristics of the Dimmable Light Ballast Demo with PFC at 25°C and 400 V DC-bus voltage.

Table 3-1. Light Ballast Characteristics

Parameter	Unit	Value
Lamp Type		F18W/33
Input Power	W	8...31
Input Current (230VAC)	mA	40...290
Preheat Output Frequency	kHz	86
Preheat Output Voltage	V _{pp}	345
Preheat Time	ms	900
Running Output Frequency Range	kHz	50...100
Running Output Voltage Range	V	200...235
Input AC Voltage	VAC	110V/60Hz, 230/50Hz
Ambient Temperature Range	°C	0.50
Power Factor		0.94...0.99
Total Harmonic Distortion	%	5.2...24.6
Output Ignition Voltage	V _{pp}	510

3.3 Application Description

The system concept is shown in [Figure 3-1](#). The system consists of:

- Control board with MC68HC908LB8 microcontroller
- Two fluorescent lamps

The MC68HC908LB8 MCU runs the main control algorithm. According to the dimming level potentiometer It generates output signals for the half-bridge inverter which controls the ballast circuit. It also controls PFC. The desired dimming value is set by the potentiometer, because the human eye is more sensitive at lower light levels. The input values from the potentiometer are converted using brightness linearization. The HRP uses a frequency control method for dimming. It incorporates hardware that allows dithering between two adjacent frequencies for smooth light level dimming.

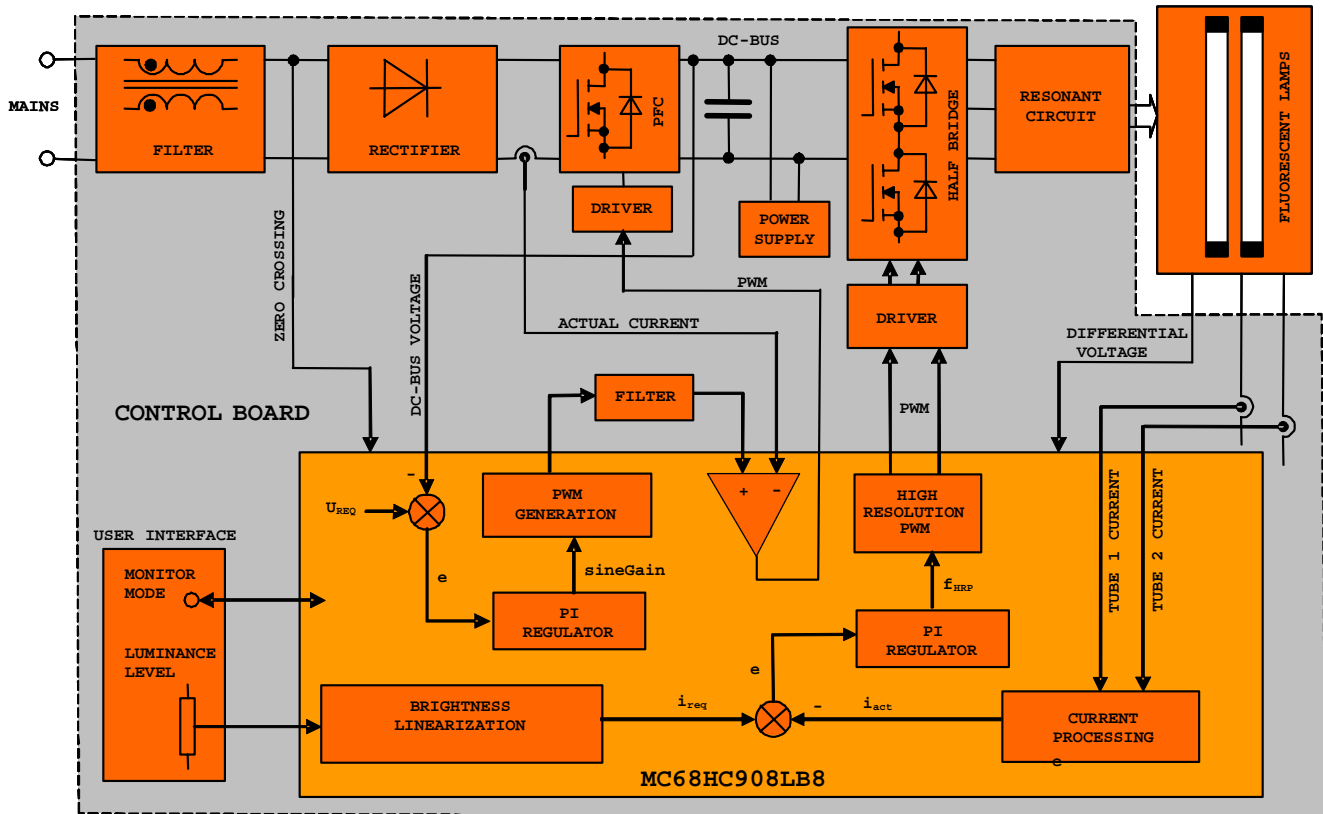

Figure 3-1. Dimmable Light Ballast — System Concept

3.3.1 Light Ballast Control

The HRP provides two complementary PWM outputs for controlling a half-bridge in a light ballast application. It uses a dithering control method to provide a high step resolution (3.9 ns) from an 8 MHz input clock when driving inductive loads.

The High Resolution PWM Module (HRP) uses a dithering technique to increase the resolution of the output signal. The output switches between two frequencies or duty cycles at a programmable rate. By varying the percentage of time spent on each frequency/duty cycle, the output will appear to be at a value between the two dithering frequencies/duty cycles when driving an inductive load.

The advantage is easy implementation of a control method for half-bridge inverter using few external devices. The main advantage is simple performance using few instructions to perform the dithering control algorithm.

3.3.2 Power Factor Correction

The power factor correction circuitry provides the “sinusoidal” input current by controlling the PFC switch. In the control loop, the actual DC-bus voltage is compared with the desired one. The control error is processed by the PI (proportional-integral) controller, which generates the amplitude of the input “sinusoidal” current. The PWM generator generates the desired sinusoidal current profile using a PWM technique. The digital output signal is filtered by a passive filter and the resulting analog waveform is compared with the actual input current by an on-chip comparator. The comparator output controls directly

the PFC switch in hysteresis current control mode or output is used for switch off PWM1 in DCM. Than PWM1 signal is used directly for switching the PFC switch transistor.

3.3.3 Protection Features

During the startup phase and run phase, some erroneous states can occur. When the DC-bus voltage does not reach the required value or is out of limits then a fault signal is generated. The DC-bus voltage is also checked against limits in run mode. If any of the previously mentioned faults occurs, all modules are disabled, lamps go out, and the fault diode blinks.

3.4 Software Specification

The software is written in C. The software specifications are listed in [Table 3-2](#). A useful feature of this application is the ability to debug software via the MON08 CYCLONE debug tool connected to JP1 header connector. The Real-Time Debugger from Metrowerks can be used as a debug tool.

Table 3-2. Software Specification

Control Algorithm	Dithering control
	Current loop control
	Voltage loop control
Target Processor	MC68HC908LB8
Language	C with some arithmetical functions in assembler
Compiler	Metrowerks ANSI-C/C++ Compiler for HC08
MCU Oscillator Frequency	16 MHz (with default software setting)
MCU Bus Frequency	4 MHz (with default software setting)
Targeted Hardware	Dimmable Light Ballast With PFC Demo Board

A detailed description of how to set Debugger for commutation with MON08 CYCLONE is given in Reference [\[2\]](#). For safe debugging it is recommended use an opto-isolation board connected between the MON08 CYCLONE and the Light Ballast Demo Board. The Opto-isolation Board user manual can be found in Reference [\[3\]](#).

3.5 Hardware Specification

The other system specifications are determined by the target hardware and lamp characteristics. The board and its connections are shown in [Chapter 4 Hardware Design](#).

This hardware set is designed for fluorescent lamp and mains voltage. The specifications for a high voltage hardware and fluorescent lamp set are listed in [Table 3-1](#). The hardware operates on 230 VAC and 110 VAC mains.

Chapter 4

Hardware Design

4.1 Hardware Implementation

This chapter covers the system hardware implementation. The dimmable light ballast board is shown in [Figure 4-1](#).



Figure 4-1. Dimmable Light Ballast - Demo Board

4.2 System Modules

The light ballast system hardware is shown in the block diagram in [Figure 4-2](#). It incorporates the controller board, powered from AC line and fluorescent tubes. As can be seen, the controller board contains four major parts:

- Input and PFC (Input EMI Filter, Bridge Rectifier, Boost topology PFC circuit, DC-bus Voltage, DC-bus Sensing, Mains Zero Crossing Sensing, Comparator Circuit, Buffer Circuit)
- Inverter (Half-bridge Drive, Resonant Circuit, Output Inductance Circuitry, Different Voltage Sensing, Tube Currents Sensing)
- Microcontroller (MC68HC908LB8)
- Power Supply (Switch Mode Power Supply)

Detailed descriptions of the individual parts of the controller boards follows. Note that the reference design includes the PCB design files and bill of materials (BOM).

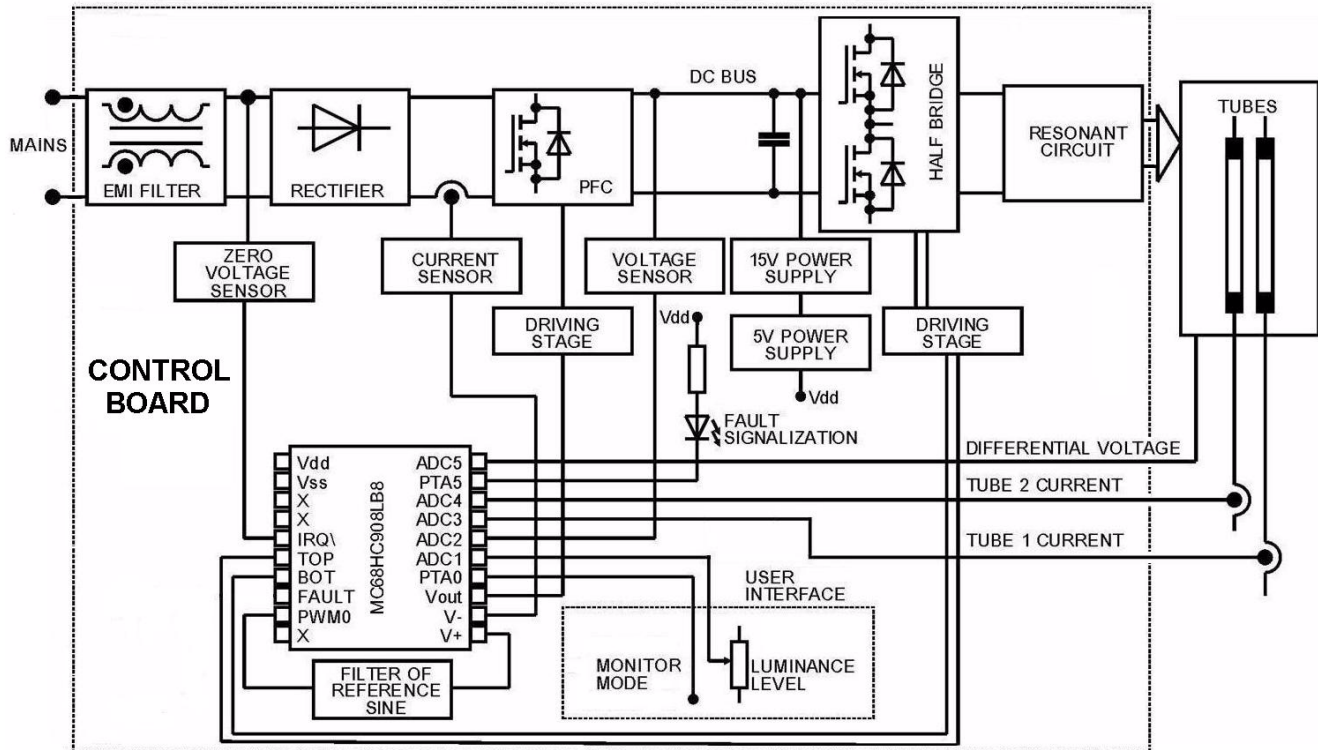

Figure 4-2. Dimmable Light Ballast with Hysteresis PFC HW variation — Hardware Block Diagram

4.2.1 Input and PFC

The input and the PFC part provide the DC-bus voltage to supply the inverter. The schematic for hysteresis current control mode is shown in Figure 4-3. The difference in discontinuous conduction mode against hysteresis mode is that the gate of Q4 is connected to pin PWM1 of the MCU (see Figure A-2), not to the output of the comparator. The input stage consists of an EMI filter and a single-phase full-bridge rectifier. Although the PFC regulator is called an active filter, it does not suppress all harmonics. For this reason, the EMI filter is placed at the input.

The PFC is based on the most popular non transformer isolated DC-DC boost (step-up) converter topology. The PFC stage is built with input inductor L1, power MOSFET switch Q1, output rectifier diode D1, and output capacitor C4. Capacitor C3 performs a filtering function. The input stage converts the mains AC voltage, rectified by the diode bridge U1, to an output DC voltage on the output capacitor C4. The current flowing through inductor L1 is sensed by the current sense resistor R4. There are two different values of resistor R4, 1.5Ω for rectified input voltage lower than half of DC-Bus voltage and 2.7Ω for higher voltage. The voltage drop over the current sense resistor corresponds to the measured current. The circuit, with resistors R3, R5, R7, R9, diodes D2 and D15, and capacitor C27 works as a mains zero-crossing detector. It senses rectified mains voltage and generates zero-crossing pulses with an amplitude of 5 volts. With the help of this detector, the microcontroller synchronizes its operation with the mains frequency.

The DC-bus voltage sensor consists of resistors R1, R2, R6, and R8. It senses the output voltage of the PFC, and its output is connected to the MCU AD converter. In hysteresis current control mode the output

signal of the comparator (Comp Out) controls the power switch Q1 through the output buffer, which consists of transistors Q2, Q3, and Q4, resistors R10, R13, R34, R35, R36, and R37, and capacitor C7. For discontinuous conduction mode the comparator output is disconnected from the Q4 transistor gate. The PWM1 pin is connected to the Q4 transistor gate.

Digital PFC is driven by the MCU. The MC68HC908LB8 peripherals used for PFC are listed below:

- AD converter — channels ADC1 and ADC2
- PWM0 for generating sine wave
- comparator
- IRQ pin for zero-crossing detection

The PFC control algorithm

- converts the sensed output voltage to a digital value
- provides software PI regulator for a voltage feedback loop
- programs its PWM channel to create the pattern of the input current
- synchronizes operation with the mains frequency using mains zero-crossing detection

The control algorithm is described in [5.2 Control Algorithm Description](#).

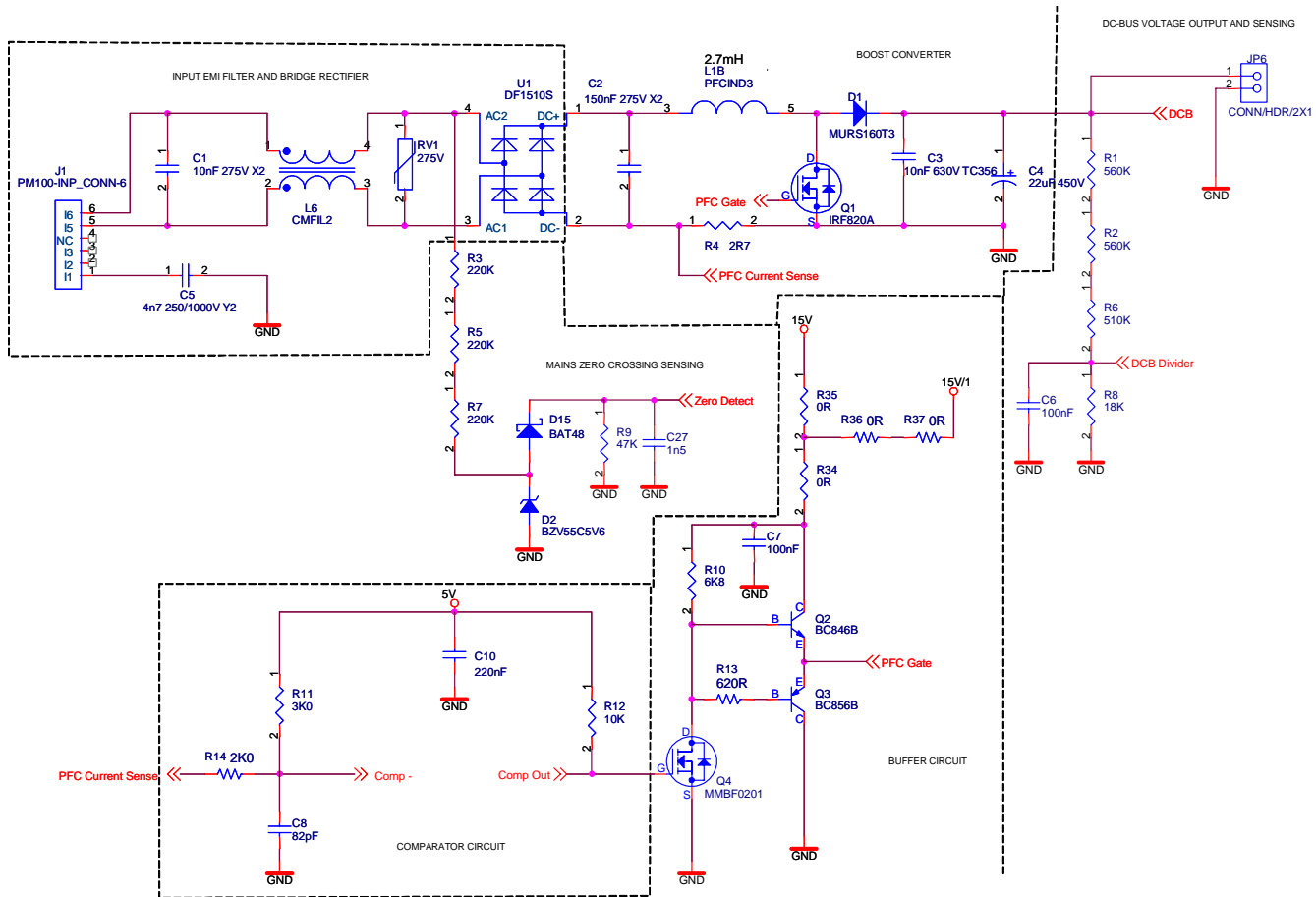

Figure 4-3. Dimmable Light Ballast — Input and PFC

4.2.2 Inverter

The power inverter generates the proper voltage for the fluorescent tubes. The power inverter consists of two MOSFET transistors driven by a half-bridge driver. It incorporates the half-bridge, a resonant circuit, different voltage and tube current sensing, and output inductance circuitry.

The half-bridge driver IR2106 from International Rectifier is electrically connected according to the manufacturer's recommendations. The half-bridge is supplied from the DC-bus voltage. It is controlled by the TOP and BOT signals from the MCU.

The half-bridge lamp resonant circuit consists of capacitor C15 and inductance L7. It provides preheating, ignition, and running operating conditions by changing the operating frequency.

The tube voltage difference circuit consist of coils L3A, L3B, and L3D, resistors R21, R24, R22, and R151, diode D8, and capacitor C17, and is used to sensing voltage differences between lamps. It helps to recognize aging of the lamps.

Coils L4 and L5 and diodes D4 and D5 are for filament preheating. Diodes maintain a small offset to remove the flickering effect. Coils L3A and L3D balance possible differences in current flow into tubes, mainly at ignition stage. Devices R19, D7, R152, D6, C16, and R20 sense the current flow in tube 1 (and similarly for tube 2).

For different tubes parameters, the tube currents are different. The ignition circuit formed by L3D, L3A, and R17 balance the current. The compensation current flows through R17 until the tube currents are equal, at which time the ignition of both tubes can be done reliably.

Tubes preheating heats the tubes to the desired temperature before startup. It decreases the wear-out and increases the life-time and reliability in startup. Also, the voltage required for ignition is smaller.

Each tube has its own preheating circuitry. Tube 1 uses L4. Tube 2 uses L5. The preheating voltage and time is set-up in software and is controlled by the TOP and BOT signals from the HRP.

The flickering effect is caused by reducing the voltage to zero during the light ballast operation. To avoid this, the Zener diodes D4 and D5 maintain a small voltage on both tubes at all times.

The output inductance circuitry performs several important functions in the light ballast application. It helps to ignite lamps, when tube parameters differ (due, for example, to different aging of the lamps). It removes the flickering effect and provides filament preheating.

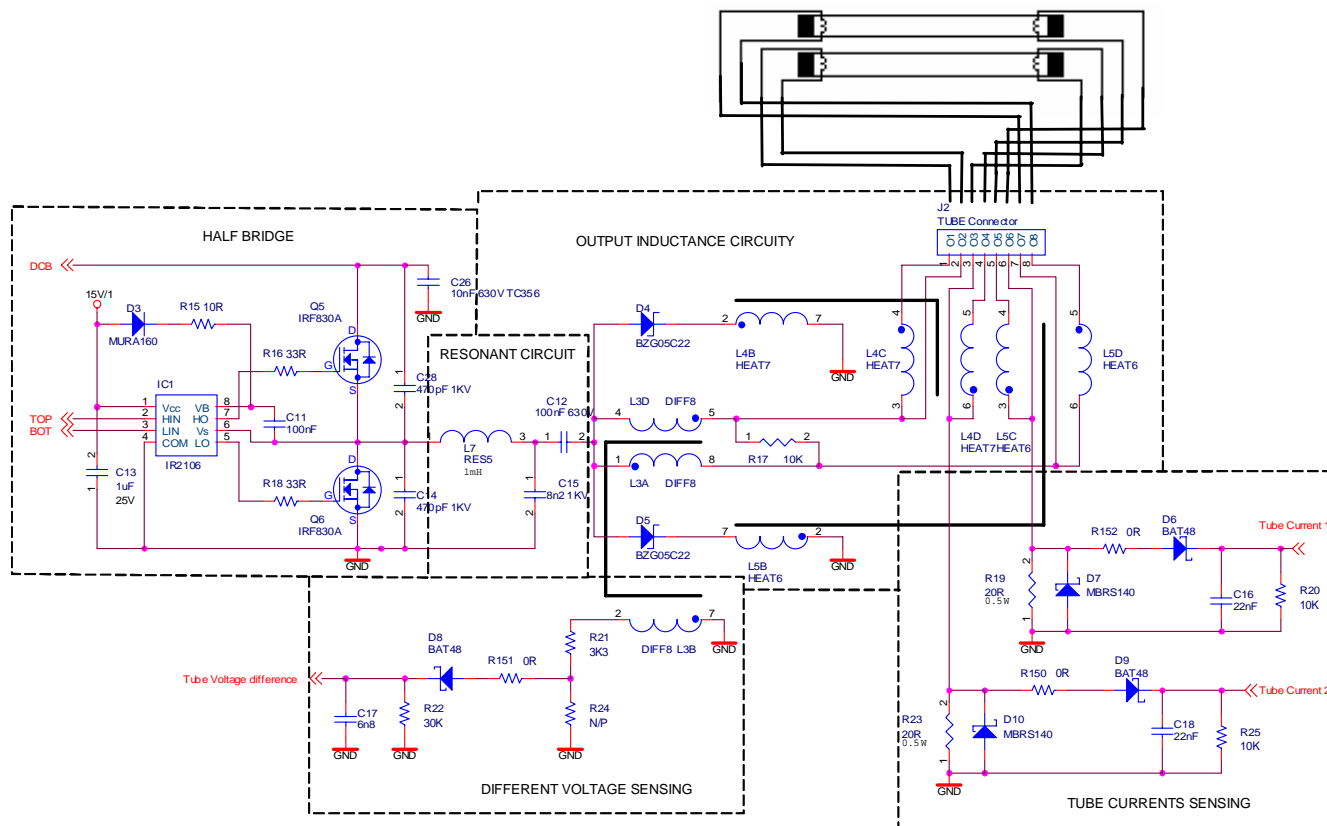

Figure 4-4. Dimmable Light Ballast — Inverter

4.2.3 Microcontroller

The MC68HC908LB8 microcontroller is the core of the application. It processes the input and feedback signals and generates appropriate control signals. The description of the pins follows.

The inverter is controlled by signals on the TOP and BOT pins of the MCU.

Signal PWM0 is used to generate a sine wave. This signal (on comparator pin V+) is compared with the real current (on comparator pin V-) in the on-board comparator. The real current is sensed using the shunt resistor R4. The signal from PWM0 is filtered in the RC filter comprised of R30, R31 and capacitor C9. The output of the comparator appears on pin VOUT.

The IRQ pin is used for the zero-crossing detection circuit and for entry to the monitor mode.

The microcontroller stage incorporates two header connectors, the Luminance Level connector and the Monitor Mode connector. The Luminance Level connector is used for the Luminance Level potentiometer (see [Table 4-1](#)). The Monitor Mode connector enables the MCU to enter the Monitor Mode. For Monitor Mode, the IRQ, OSC1, PTA0, and PTA1 pins are used (see [Table 4-2](#)).

The Fault LED is connected to pin PTA5; it indicates the actual state of the application.

DC-bus shift-down voltage is sensed on pin ADC2.

Real currents through tube1 and tube2 are sensed on pins ADC3 and ADC4. The tube voltage difference is sensed on pin ADC5.

In the discontinuous conduction mode HW variation, PWM1 pin is used directly for switching the PFC switch transistor (see [Figure A-5](#)). Comparator output is internally connected to the PWM fault pin. In the hysteresis current control mode HW variation, it is not used.

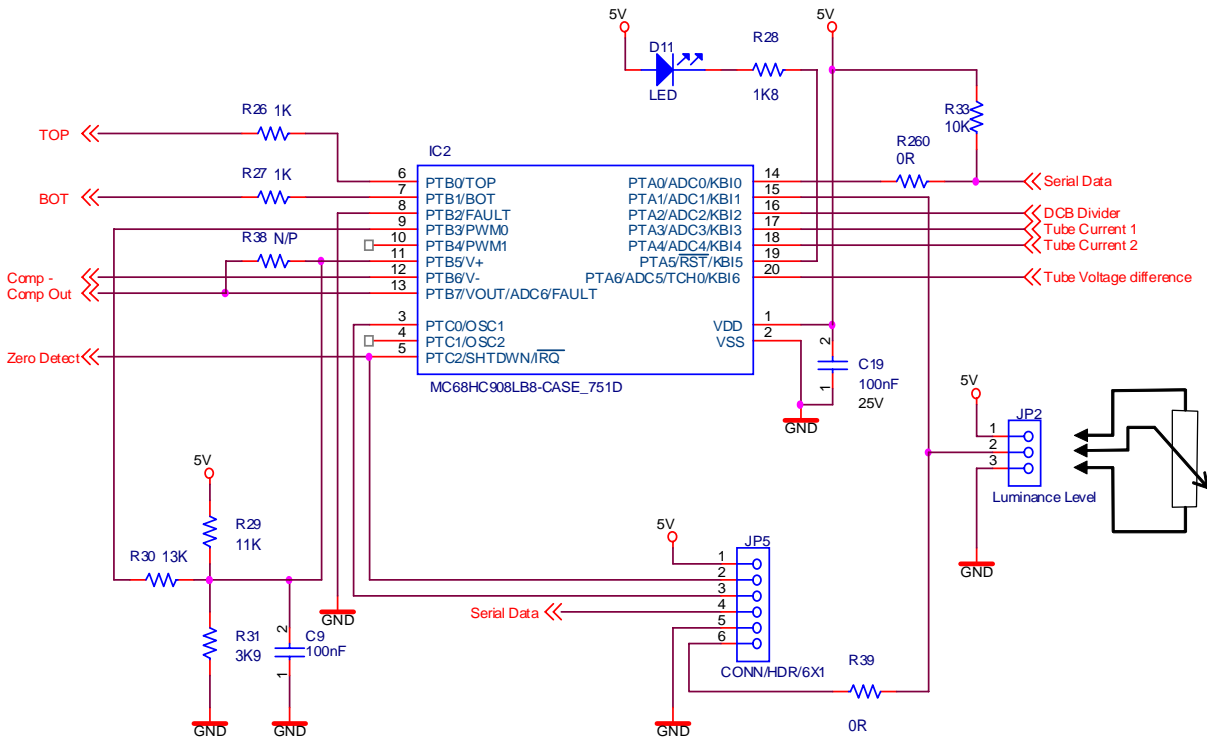

Figure 4-5. Dimmable Light Ballast — Microcontroller

NOTE

The Luminance Level potentiometer should be connected to the PCB in the required manner. This means that if the potentiometer is in a zero position, a 0% Luminance is required and 0V must be available on pin 2 of connector JP2.

Table 4-1. J1 Luminance Header

Pin number	Signal
1	+5V
2	PTA1
3	GND

Table 4-2. J2 Interface Header

Pin number	Signal
1	+5V
2	PTC2
3	PTC0
4	PTA0
5	GND
6	PTA1

4.2.4 Power Supply

The function of the switch mode power supply (SMPS) is to feed the inverter and output buffer circuit with 15 V and to supply the microcontroller stage by 5 V (see Table 4-3). The SMPS is supplied from the DC-bus voltage. It uses the monolithic high-voltage regulator NCP1010 from ON Semiconductor connected as recommended by the manufacturer. It can provide 15 VDC @ 100 mA. To achieve a 5 V power supply from a 15 V source, a step-down resistor R32, 5V1 Zener diode D13, and filtering capacitor C25 are used.

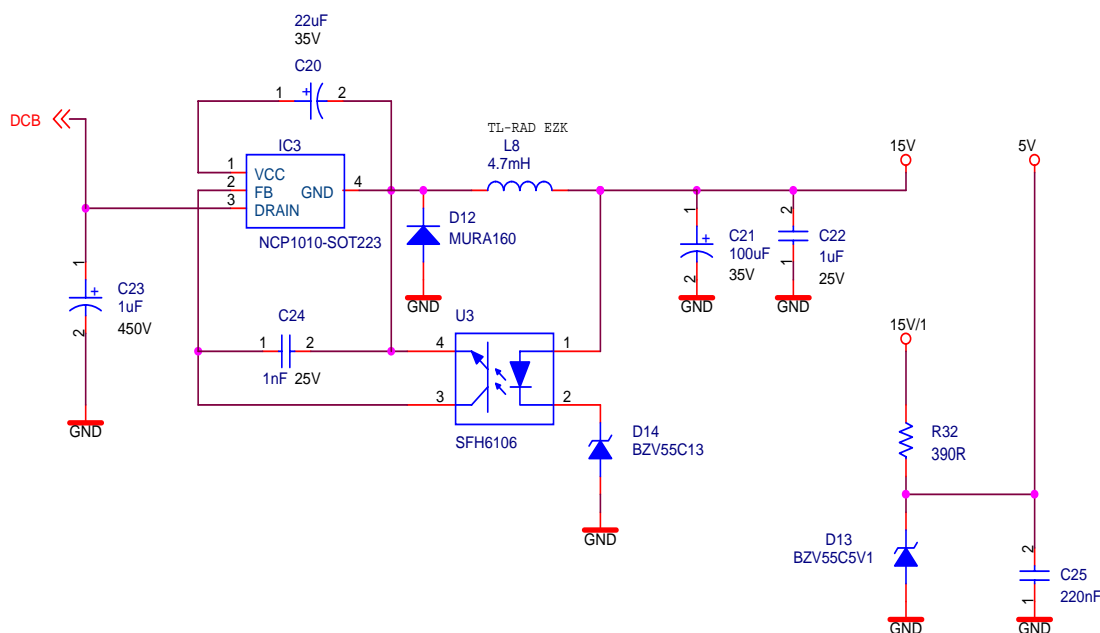

Figure 4-6. Dimmable Light Ballast — Power Supply

Table 4-3. Supplied Voltages

Voltage	Supply
+15V	Driving stage, Output buffer circuit
+5V	Microcontroller stage

Chapter 5

Software Design

5.1 Introduction

This section describes software features and behavior of the software in all function modes. The software is described in terms of:

- Control Algorithm Description
- Software Implementation
- Detailed Software Description
- Microcontroller Usage
- Constant and Variable Definitions

5.2 Control Algorithm Description

The application performs dimmable light ballast for fluorescent lamp control and PFC control. It uses microcontroller built-in peripherals. Figure 5-1 shows the high level software block diagram for hysteresis current control mode HW variation. Software block diagram for DCM HW variation is not placed because diagram is very similar. As can be seen, the PFC Control and Light Ballast Control are separate routines.

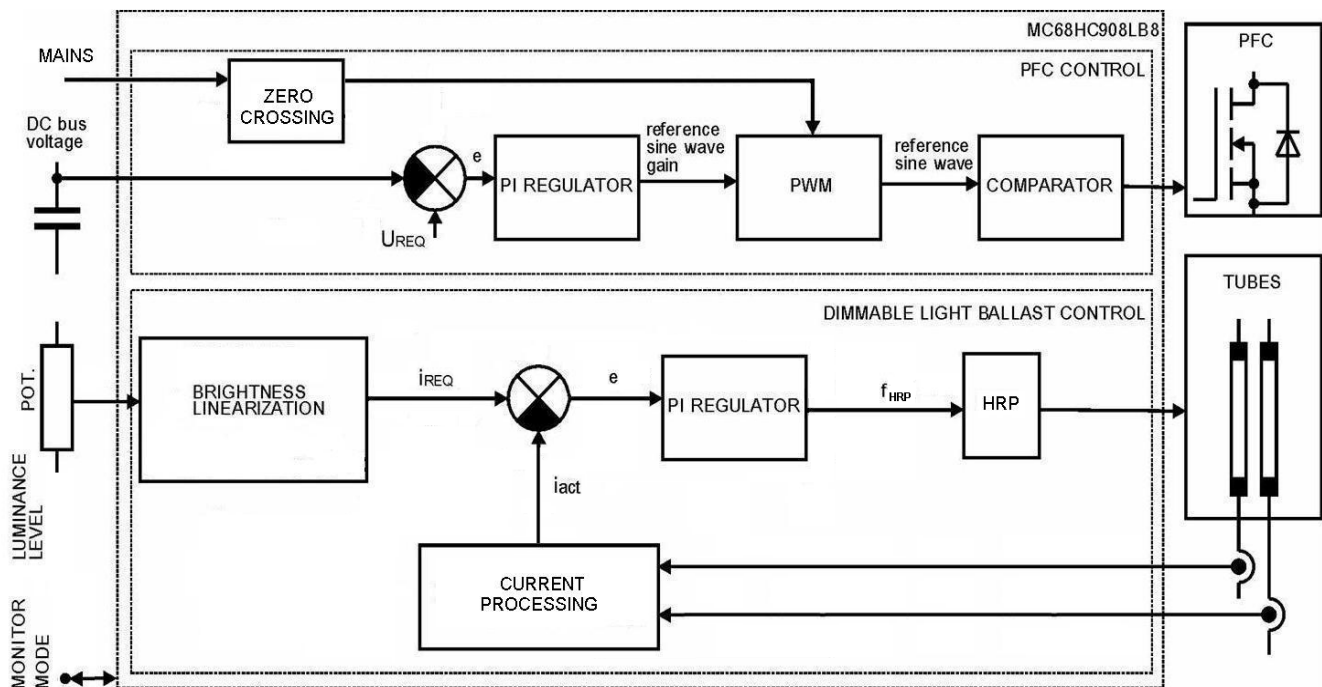

Figure 5-1. Dimmable Light Ballast with Hysteresis PFC HW Variation — Software Block Diagram

5.2.1 Power Factor Correction Control

PFC control consists of DC-bus voltage control using the PI controller, phase shift synchronization, reference sine wave generation and generation of output PFC control signals. It also includes the trimming of the internal oscillator frequency according to the frequency of the mains provided.

5.2.1.1 DC-bus Voltage Control

The actual value of the DC-bus voltage is sensed by the AD converter. This value is compared with the required DC-bus value. The regulation error is then the input value for the PI regulator. The output value from the PI regulator is the reference sine wave gain. The PWM module generates a reference sine wave with calculated amplitude. The filtered reference sine wave is compared with the actual current using the on-chip comparator. For the hysteresis current control mode HW variation, the output from the comparator is the switching signal for the PFC MOSFET transistor. For the discontinuous conduction mode HW variation, the output comparator is connected to the PWM fault pin. The PWM1 signal is directly used for switching the PFC MOSFET transistor.

5.2.1.2 Phase Shift Synchronization

Phase shift synchronization synchronizes the generated PFC reference sine wave to the frequency of the mains. It is realized by means of:

- *Zero voltage crossing detection (zero voltage sensor)*
The zero voltage crossing sensor generates a falling edge every time when the input voltage crosses zero from positive to negative polarity.
- *External interrupt*
An external interrupt is triggered by the zero voltage crossing sensor. The interrupt subroutine is used to get the content of timer TIM registers TCNTH:TCNTL for automatic microcontroller trimming and for PFC reference sine wave amplitude gain calculation in lamp run mode.
- *MCU oscillator frequency trimming*
For microcontroller automatic trimming, the timer TIM is used as an interval counter. The timer is incremented by the internal clock (divided by prescaler). Its content is cleared every $\overline{\text{IRQ}}$ interrupt produced by the voltage zero crossing sensor. A user defined value determines what number should be found in TIM registers TCNTH:TCNTL. On the basis of the comparison between required and actual counter values, the content of the oscillator trim register OSCTRIM is adjusted with ramp.

5.2.1.3 Reference Sine Wave Generation

Reference is performed by the PWM peripheral. The software contains a sine wave table with values for interval and maximum amplitude. The amplitude of the sine wave depends on the value of the DC-bus voltage and it is adjusted by the PI controller every 20ms. Two different sets of PI controller parameters are used, one for MCU startup, when the DC-bus voltage must reach the required value quickly and HRP is not activated, and the second during standard running operation.

5.2.1.4 Generation of Output PFC Control Signal

The generated output PFC signal controls the PFC power MOSFET. An on-chip operational amplifier is used in comparator mode. It compares the reference sine wave, filtered by the RC filter, with the actual current and generates a switching signal for the PFC MOSFET transistor in the hysteresis current control mode HW variation. In discontinuous conduction mode comparator output is used for switching off the PWM1 signal. It works as a fault detection in fact. When the actual current sensed on the shunt resistor

is higher than the generated sine waveform, then the comparator output is in log.1 and PWM1 is switched off. This happens every PWM period and this process is called cycle by cycle limiting. PWM1 operates at a 40 kHz frequency with variable duty cycle. For safety reasons, the comparator is enabled when the microcontroller is initialized and mains voltage synchronization is provided.

5.2.2 Light Ballast Control

Light Ballast Control controls the fluorescent tubes. The control process consists of two parts (modes), tube start mode and tube run mode. Figure 5-2 shows the software control time diagram during start mode and run mode.

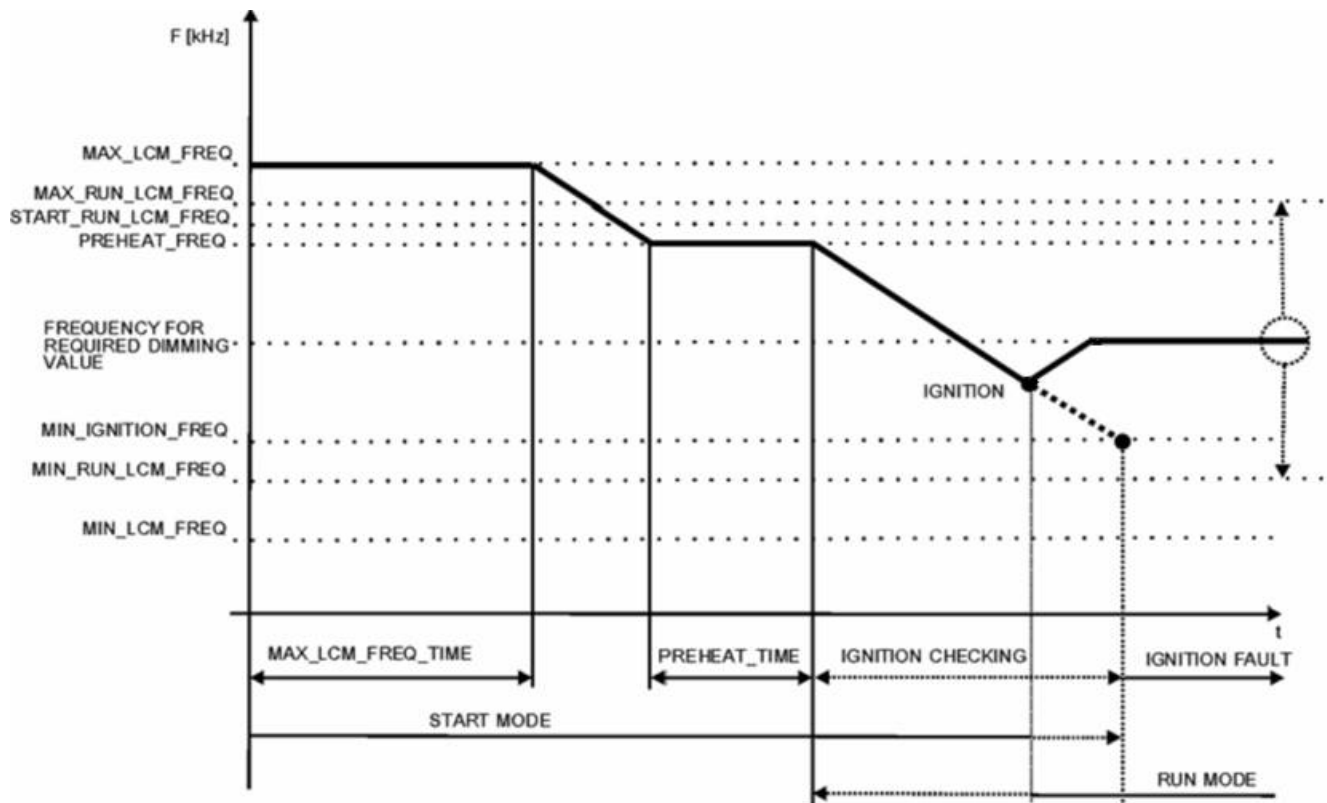

Figure 5-2. Dimmable Light Ballast — Control Time Diagram

5.2.2.1 Tube Start Mode

When the DC-bus voltage reaches the required value, the HRP is enabled at maximum ballast frequency and kept for a set time. Then the ballast frequency is ramped down to the preheat frequency and kept for a set time. This procedure preheats the filaments. In the next stage, the ballast frequency is ramped down until the lamps are ignited. During the lamp ignition procedure, the frequency and tube currents are controlled (see Reference [4]).

5.2.2.2 Luminance Level Control (Tube Run Mode)

Luminance Level Control is active after tube ignition. The actual values of the tube currents are sensed by the AD converter. Average value of currents is compared with required current value after luminance

level adjustment (brightness linearization). The regulation error is then the input value for the PI regulator. The output value from the PI regulator is the HRP period for half bridge power stage.

Input required luminance level adjustment adapts the required luminance level to its exponential value. This is done because of the nonlinear function dependence of luminance on the lamp current. The transformation table is used. The table contains the required current values.

The values in the table can be calculated using the following expression.

$$i_{req} = A \cdot e^{k \cdot i_{reqAD}} + q \tag{EQ 5-1}$$

where:

- i_{reg} is the required current in the exponential expression used for the control algorithm calculation
- i_{regAD} is the required current measured by the AD converter
- A is the exponential curve gain
- q is the exponential curve offset

To calculate the coefficients A and q correctly, the following values must be known.

- | | |
|--|--------------|
| • Minimum HRP frequency | f_{min} |
| • Maximum HRP frequency | f_{max} |
| • Tube current measurement range | i_{max} |
| • Minimum required tube current | i_{tmin} |
| • Maximum required tube current | i_{tmax} |
| • ADC maximum value | AD_{max} |
| • ADC minimum value | AD_{min} |
| • Minimum required tube current value converted to ADC range | i_{tADmin} |
| • Maximum required tube current value converted to ADC range | i_{tADmax} |
| • k determines function precision | |

Then:

$$i_{tADmin} = \text{round}(i_{tmin} \cdot AD_{max} / i_{max}; 0) \tag{EQ 5-2}$$

$$i_{tADmax} = \text{round}(i_{tmax} \cdot AD_{max} / i_{max}; 0) \tag{EQ 5-3}$$

$$A = \frac{i_{tADmax} - i_{tADmin}}{e^{k \cdot AD_{max}} - e^{k \cdot AD_{min}}} \tag{EQ 5-4}$$

$$q = i_{tADmin} - A \cdot e^{k \cdot AD_{min}} \tag{EQ 5-5}$$

This is a time-consuming calculation, but it can be simplified by using the sheet “HRP_Setup” provided in the Excel file “DLB_Setup.xls”. This file can be downloaded along with this designer reference manual.

5.3 Software Implementation

The general software implementation is illustrated in [Figure 5-3](#). It incorporates the main routine entered from Reset and three interrupt states. The main routine includes the initialization of the microcontroller including PWM, HRP, ADC, and pins used in the application, and sets initial values for the PI regulator. The infinite loop is performed as long as board remains connected to the mains and no fault conditions are detected.

The interrupt states provide for trimming the internal oscillator, mains synchronization, reference sine wave generation, and fault detection and processing.

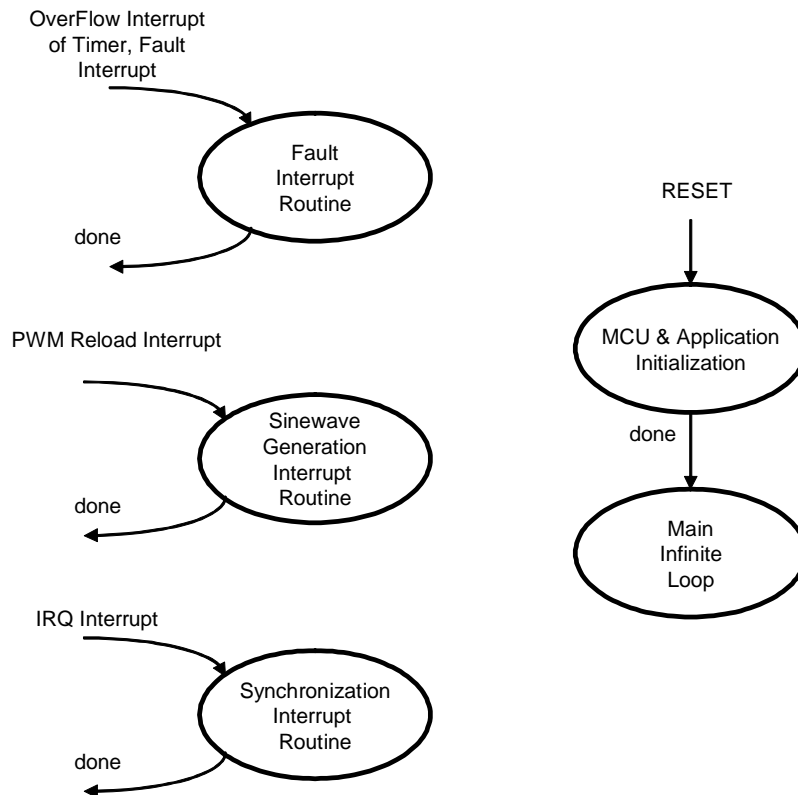

Figure 5-3. Software Implementation

5.3.1 Initialization Setup

Prior to running the main program loop, the initialization setup sets the microcontroller operation mode and peripherals. The quickest way to set and PWM is to use the auxiliary Excel sheet Reference [4]. To achieve the required system behavior and communication with peripherals, the following registers and initial values are set.

- Set configuration registers CONFIG1 and CONFIG2 at the beginning of the initialization; they can be written once only after each reset.
 The register CONFIG1 sets:
 - long COP time-out period
 - enable LVI module
 - disable STOP instruction

The register CONFIG2 sets:

- internal oscillator
- IRQ interrupt enabled
- IRQPUD must be 0 to connect the internal pullup resistor between IRQ pin and V_{dd} .
- IRQ status and control register INTSCR sets:
 - IMASK enable IRQ interrupt requests
 - IRQ interrupt on falling edge only
- Analog to digital converter clock register (ADCLK)
 - sets the ADC clock. ADC clock = bus clock / prescaler. The recommended value for the ADC clock is 1 MHz.
- PWM setup — void Set_PWM(void)
 The subroutine initializes PWM values, and sets 0% duty cycle on PWM.
 For a better understanding of PWM setup and logic, see [5.3.1.1 PWM Setup](#).
- HRP setup — void Set_HRP(void)
 The subroutine initializes and sets HRP registers. For a better understanding of HRP setup and logic, see [5.3.1.2 HRP Setup](#).

5.3.1.1 PWM Setup

The PWM module can generate two independent PWM signals used for PFC control. These signals are edge-aligned. PWM resolution is one clock period which is dependent on the internal bus frequency (BUSCLK) and a programmable prescaler (PRSC0, PRSC1). Also, programmable fault protection and PWM signal polarity controls are provided.

For the application, the PWM is set to 40 kHz, resulting in 101 levels of PWM0 at a 4 MHz bus frequency. Because of the hardware configuration, negative polarity control of the PWM output is required.

For proper operation of the PWM module, the following registers must be set:

- PWM counter modulus registers PMODH and PMODL hold a 12-bit unsigned number that determines the maximum count for the up-only counter. It is set to 100.
- PVAL0H and PVAL0L registers determine duty cycle value (duty cycle = PVAL0/PMOD*100). In initialization phase this is set to 0.
- PCTL1 register controls PWM enabling/disabling, the location of the PWM Fault bit, the loading of new modulus, prescaler, and PWM values, and the PWM correction method.

In the application, PCTL1 is set as follows:

- Fault pin is PTB7
- interrupt is enabled
- load new values active
- module enabled
- PCTL2 register controls the PWM reload frequency, PWM channel enabling/disabling, the PWM polarity, the PWM correction method, and the PWM counter prescaler. For safety reasons, some of these register bits are buffered. The PWM generator will not use the prescaler value until the LDOK bit has been set and a new PWM cycle is starting. The load frequency bits are not used until the current load cycle is complete.

In the application, PCTL2 is set as follows:

- PWM0 enabled
- PWM1 enabled
- PWM0 negative polarity control
- reload frequency bits LDFQ0 and LDFQ1 to 0 — reload every PWM cycle

- PWM clock frequency set to BUSCLK by prescaler bits PRSC0 and PRSC1
- DISMAP is a write-once register which controls the PWM pins to be disabled if an external fault occurs. When this register is written for the first time, it cannot be rewritten unless a reset occurs. PWM0 is not disabled when an external fault appears. PWM1 is disabled if an external fault appears.
- The FCR register controls the fault protection circuitry. A fault does not cause a CPU interrupt in hysteresis current control mode. The fault protection circuitry operates in automatic mode for DCM HW variation. In hysteresis current control mode operates in manual mode.

The PWM frequency is affected by the setup of the internal bus frequency, PWM modulus registers PMODH, PMODL, and the prescaler value in the PRSC0 and PRSC1 registers. Consequently, the PWM frequency is given by the equation:

$$\text{PWM Frequency} = \frac{\text{BusFrequency}}{\text{PMOD} \times \text{PRSC}[0:1]} \quad [\text{Hz}; \text{Hz}, -, -] \quad (\text{EQ 5-6})$$

According to the setting, the PWM frequency is 40 kHz.

5.3.1.2 HRP Setup

The HRP provides two complementary outputs for controlling a half-bridge in a light ballast application. It uses a dithering control method to provide a high step resolution (< 4 ns) from an 8 MHz input clock when driving inductive loads.

For the to operate properly, the HRP registers must be set correctly. The HRP works in variable frequency mode with 50% duty cycle. The output frequency varies from 40 kHz up to 120 kHz, depending on the level of dimming required. The MCU BUSCLKX2 is 8 MHz. The transistors controlling the lamp require a deadtime of 1 μ s. The deadtime must be set by software.

Four steps are required to configure the HRP:

1. Set the dithering timebase to the appropriate value
2. Set the deadtime to the appropriate value
3. Set HRPPERH:HRPPERL to select the desired frequency
4. Select variable frequency mode and enable the module

Detailed description follows:

1. Set the dithering timebase to appropriate value:

The dithering timebase is determined by HRPTBH:HRPTBL registers. It should be calculated according to the condition:

$$\text{Dithering timebase (seconds)} \geq (1/\text{max ballast frequency})$$

$$\text{HRPTBH:HRPTBL} = (1/\text{max ballast frequency}) * \text{BUSCLKX2}$$

In this case, dithering timebase = 1/120 kHz = 8.33 μ s

For BUSCLKX2 = 8 Mhz, the HRPTBH:HRPTBL = \$0054

2. Set deadtime to appropriate value:

The deadtime is defined by HRPDT register.

The transistors used in the ballast require 1 μ s of deadtime to prevent both being on at the same time.

$$\text{HRPDT register} = \text{required deadtime} / (1 / \text{BUSCLKX2})$$

For BUSCLKX2 = 8 MHz, the HRPDT= \$08

3. Set HRPPERH:HRPPERL to select the desired frequency (e.g. 88 kHz)

The period of 88 kHz = 1/88 kHz

Output period (seconds) = HRPPERH:HRPPERL / (BUSCLKX2 * 32)

then,

$$\text{HRPPERH:HRPPERL} = 1/88 \text{ kHz} * (\text{internal bus frequency} * 32) = 2909 = \$B5D$$

4. Select variable frequency mode and start the HRP

Writing \$01 to the HRPCTRL register configures the module for variable frequency mode (HRPODE = 0) and enables the module (HRPEN = 1).

5.3.2 Main Program Loop

The functions of the main program can be broken down into several chronological phases, as follows:

1. Check required DC-bus voltage
2. Go to maximum ballast frequency
3. Apply maximum ballast frequency for start time
4. Go to preheat frequency
5. Apply preheat frequency for preheat time
6. Go to ignition frequency
7. Run mode

After the initialization stage, the software checks the DC-bus voltage value. When the DC-bus voltage does not reach the required value within the start time or the value is out of limits then the faultISR routine is launched.

In phase 2, the HRP frequency is set to the maximum ballast frequency, and this is maintained for the start time in phase 3.

In phase 4, the HRP frequency is ramped down to the preheat frequency, and this is maintained for the preheat time in phase 5.

In phase 6, the HRP frequency is ramped down to the ignition frequency. If the minimum ballast frequency is reached, then the controller tries again to ignite the lamps. If, in a defined number of attempts, the lamps did not ignite, the ignition is interrupted and the faultISR routine is launched.

Phase 7 is Run mode - a never ending loop. During this phase, the required dimming value is sensed from the dimming level potentiometer. The dimming value is sensed every ADDMININTERVAL. The tube currents are measured every cycle in never ending loop. The ballast frequency is control by PI regulator every 500us according required dimming level sensed from dimming potentiometer.

5.3.3 Synchronization Interrupt Routine

The interrupt procedure is used for trimming the internal oscillator and for synchronization of the phase shift of the reference sine wave with the mains voltage. A detailed illustration of this is shown in [Figure 5-4](#).

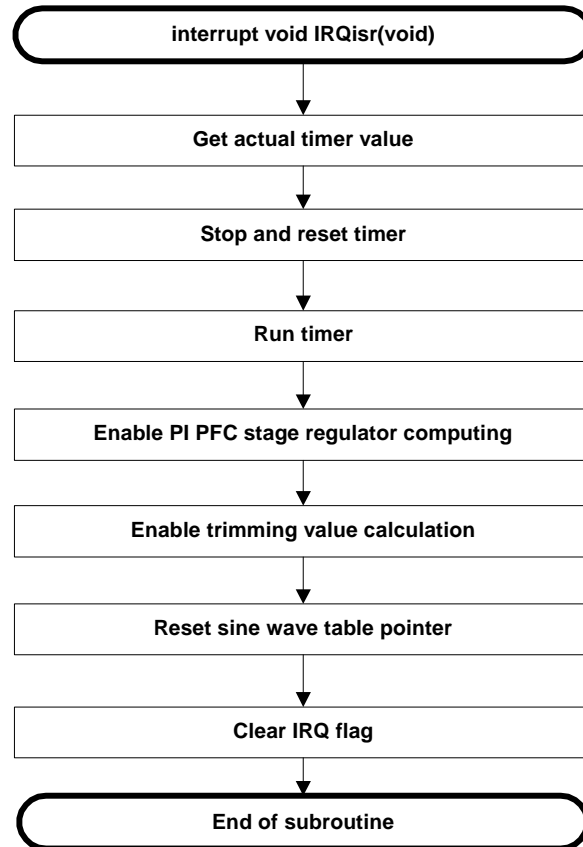

Figure 5-4. Flow Chart — Synchronization Interrupt Routine

5.3.4 Sine Wave Generation Interrupt Routine

The PWM modulator is used to generate the reference sine wave for PFC control. The amplitude of generated sine wave depends on output DC-bus voltage and it is calculated by means of PI regulator. The phase shift of the sine wave is synchronized by means of $\overline{\text{IRQ}}$ interrupt that is launched by input AC voltage zero crossing detector. The table `bSinTab[PWM_RELOADS]` contains duty cycle values for PWM. These values can be calculated by means of worksheet `PWM_Setup` of the file `DLB_Setup.xls` (see Reference [4]). For service PWM reload interrupt the `pwmlsr()` routine is used (see [Figure 5-5](#)). Moreover, inside the PWM, a counter generates a reload interrupt signal every 1 ms. This interval is used for software timing.

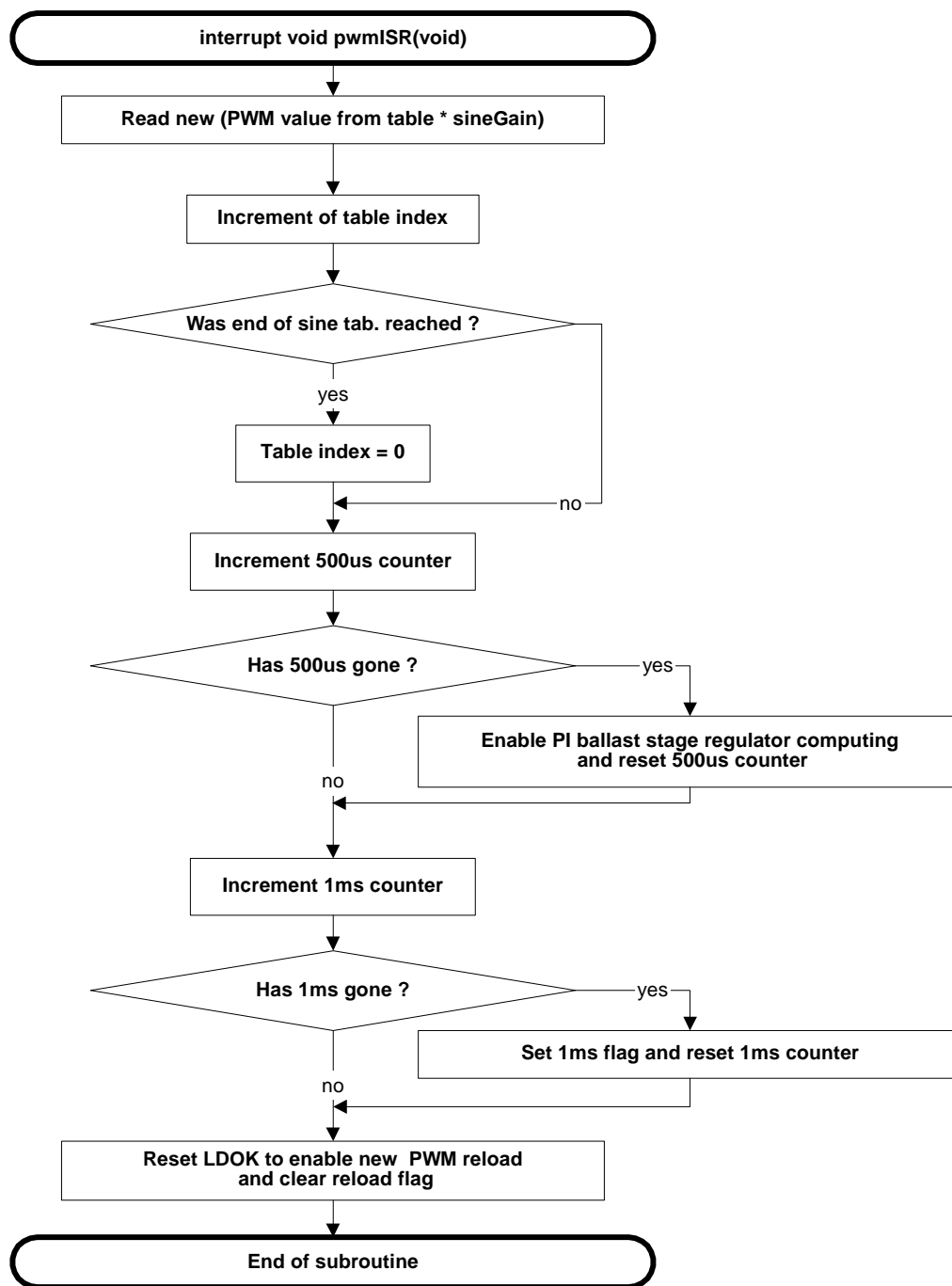

Figure 5-5. Flow Chart — Sine Wave Generation Interrupt Routine

5.3.4.1 Fault Detection and Processing

The following application faults are detected by the software:

- DC-bus under voltage
- DC-bus over voltage
- Failure of the DC-bus voltage to reach the required value within the start time
- Zero current fault
- Ignition fault
- COP overflow

A zero current fault launches the `faultISR` routine when one of the tube currents is zero during the zero current checking interval in run mode for the specified time.

An ignition fault launches the `faultISR` routine when the lamps do not ignite within a specified number of attempts.

All these fault states are serviced by the following fault service routines:

- `timovISR()` — services interrupts from TIM
- `faultISR()` — services HRP fault interrupts and all other faults

The `timovISR` routine is launched when the COP counter overflows (this occurs when the correct input voltage is missing). The `timovISR` routine calls the `faultISR` routine (see [Figure 5-6](#)).

The `faultISR` routine serves all fault states. It disables all interrupts, stops PWM, HRP, TIM, CM (see the flow chart in [Figure 5-6](#)). The fault state is indicated by the fault diode blinking in a never ending loop.

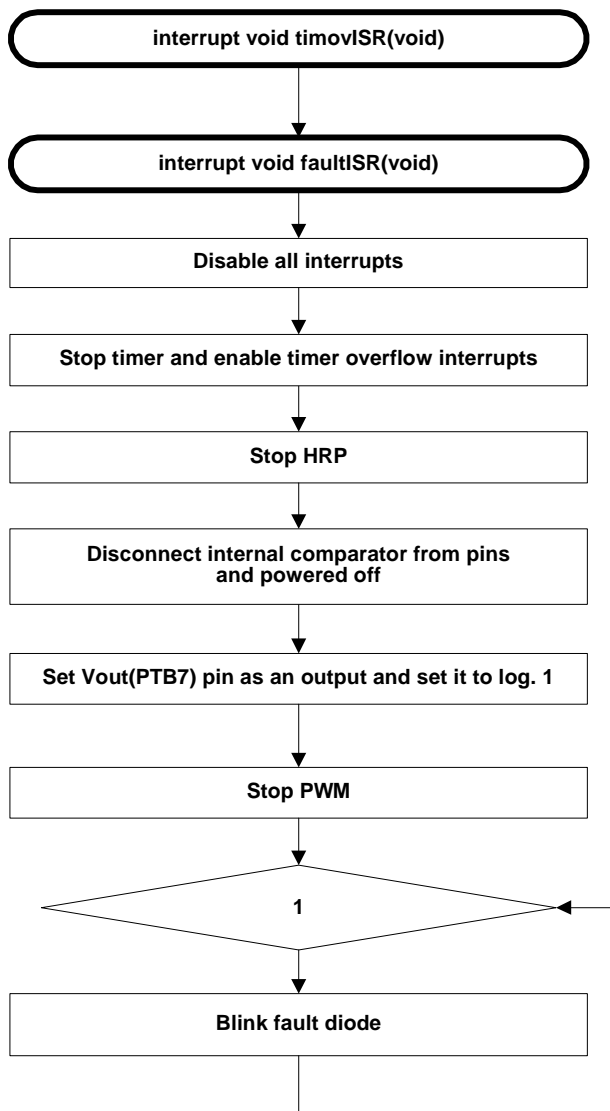

Figure 5-6. Flow Chart — timovISR and faultISR

5.4 Detailed Software Description

This section provides a detailed graphical description of the software. It explains each particular part of the application software in detail.

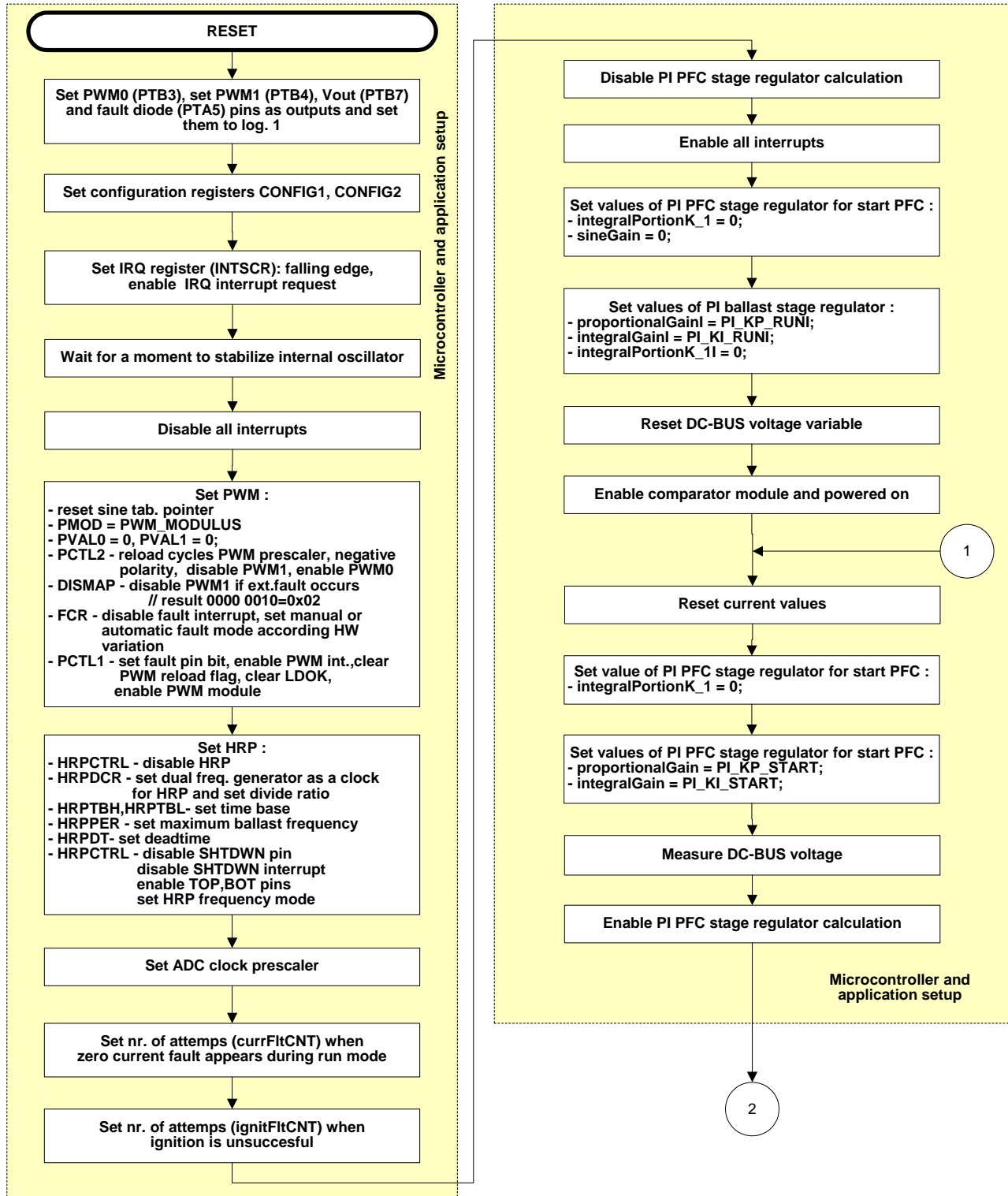

Figure 5-7. Flow Chart — Main Flow, Part 1



Figure 5-8. Flow Chart — Main Flow, Part 2

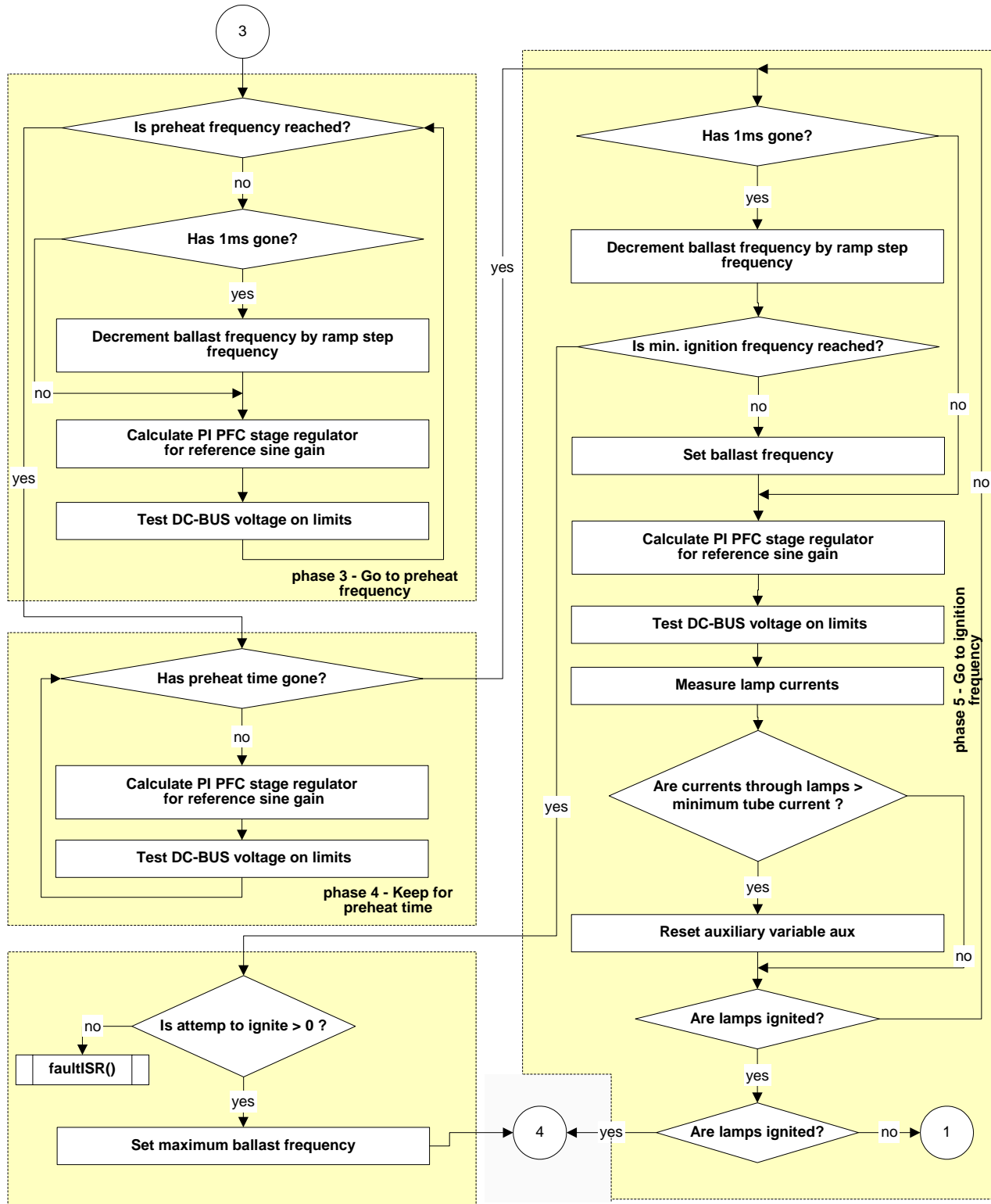

Figure 5-9. Flow Chart — Main Flow, Part 3

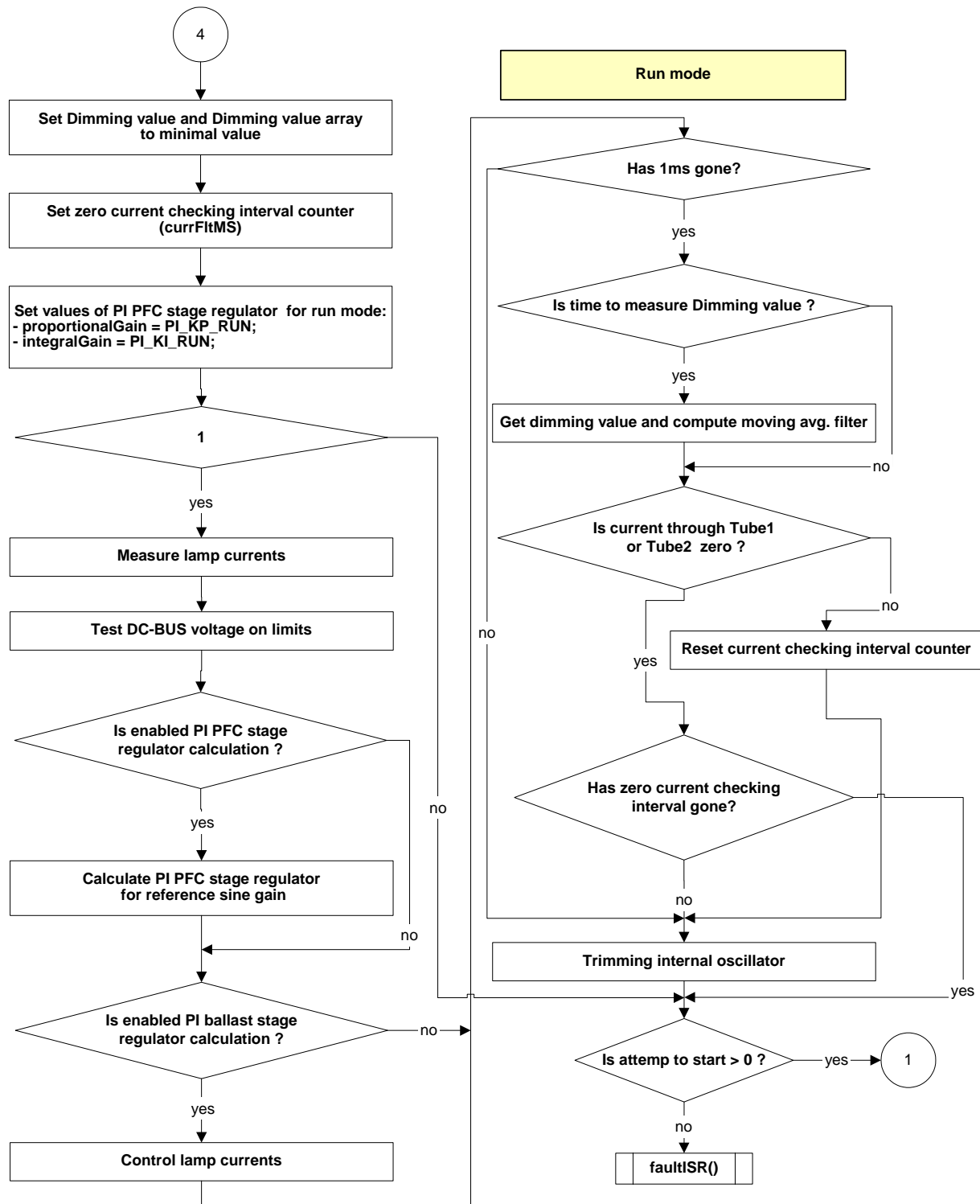

Figure 5-10. Flow Chart — Main Flow, Part 4

5.5 Microcontroller Usage

5.5.1 Microcontroller Peripheral Usage

5.5.1.1 High Resolution PWM (HRP)

The HRP controls the ballast half-bridge power stage. The module is configured for frequency mode (constant 50% duty cycle, variable frequency, deadtime). For setting up the module, the worksheet HRP_Setup in file DLB_Setup.xls can be used (see Reference [4]).

5.5.1.2 Pulse-Width Modulator (PWM)

The PWM modulator is used to generate the reference sine wave for PFC control by PWM signal. The PWM1 signal is used only in the discontinuous conduction mode HW variation to directly switch the PFC switch transistor. For service PWM reload interrupt the `pwISR()` routine is used (see Figure 5-5).

5.5.1.3 Comparator Module (CM)

The comparator module is used to compare the reference sine wave signal for PFC control with the actual current value. The result is the control signal for the PFC power MOSFET transistor in the hysteresis current control mode HW version. In the DCM HW version the comparator output is used for switching off the PWM1 signal.

5.5.1.4 Timer Interface Module (TIM)

Since an internal oscillator is used and its features do not guarantee constant frequency, this module is used to automatically trim the internal oscillator to the base of frequency of the mains voltage supply (PLL). The timer counts the time between two zero input voltage detections (\overline{IRQ}); the resulting timer content is compared to the expected value, and the trimming register is adjusted accordingly (see Figure 5-4).

5.5.1.5 External Interrupt (\overline{IRQ})

The external interrupt is active on pin \overline{IRQ} . The interrupt procedure is used for trimming the internal oscillator and synchronizing the phase shift of the reference sine wave with the mains voltage. The `IRQISR()` routine is used to service the \overline{IRQ} interrupt.

5.5.2 Program and Data Memory Usage

Table 5-1 shows the memory that is used by the software. A significant part of the memory remains available.

Table 5-1. Memory Usage

Memory	Available on LB8	Used
ROM	8192 Bytes	3010 Bytes
RAM	128 Bytes	40 Bytes

5.5.3 I/O Usage

Table 5-2 summarizes the use of the I/O pins.

Table 5-2. I/O Usage

I/O pin	Direction	Purpose
PTC0/OSC1	INPUT	OSC1(EXTERNAL OSCILLATOR IN MONITOR MODE)
PTC1/OSC2	-	UNUSED
PTC2/SHTDWN/ $\overline{\text{IRQ}}$	INPUT	$\overline{\text{IRQ}}$ (MAINS ZERO CROSSING DETECTION/ $\overline{\text{IRQ}}$ IN MONITOR MODE)
PTB0/TOP	OUTPUT	TOP (HRP OUTPUT)
PTB1/BOT	OUTPUT	BOT (HRP OUTPUT)
PTB2/FAULT	-	UNUSED
PTB3/PWM0	OUTPUT	PWM0 (REFERENCE SINUS WAVE GENERATING)
PTB4/PWM1	OUTPUT	SWITCHING PFC TRANSISTOR ONLY IN DCM HW VARIATION
PTB5/V+	INPUT	V+ (COMPARATOR INPUT)
PTB6/V-	INPUT	V- (COMPARATOR INPUT)
PTB7/VOUT/ADC6/FAULT	OUTPUT	VOUT (COMPARATOR OUTPUT) AND MOREOVER AS PWM FAULT PIN IN DCM HW VARIATION
PTA0/ADC0/KBI0	INPUT/OUTPUT	PTA0 (COMMUNICATION PIN IN MONITOR MODE AND FOR SERIAL BOOTLOADER PROGRAMMING)
PTA1/ADC1/KBI1	INPUT	ADC1 (LUMINANCE LEVEL /PTA1 IN MONITOR MODE)
PTA2/ADC2/KBI2	INPUT	ADC2 (DC-BUS VOLTAGE)
PTA3/ADC3/KBI3	INPUT	ADC3 (TUBE CURRENT 1)
PTA4/ADC4/KBI4	INPUT	ADC4 (TUBE CURRENT 1)
PTA5/ $\overline{\text{RST}}$ /KBI5	OUTPUT	PTA5 (USER LED)
PTA6/ADC5/TCH0/KBI6	INPUT	ADC5 (TUBE VOLTAGE DIFFERENCE)

The installation CodeWarrior Version 3 Service Pack for LB8 is part of the Emulation Board software. This includes examples of how to tune and work with the HRP.

5.6 Definitions of Constants and Variables

This section provides definitions of the constants and variables used in the program. The definitions can be divided into two parts:

- System setup definitions
- System constants and variables

5.6.1 System Setup Definitions

The following constants can be used to set up the system behavior, according to required conditions.

1. `#define HW_VAR HYST`
...defines HW variation - hysteresis current control mode (HYST) or discontinuous conduction mode (DCM).
2. `#define INP_VOLT U110V`
...defines input voltage lower (U110V) or higher (U230V) than half of DC-bus voltage.
3. `#define INPVOLTFREQ 50`
...defines the mains voltage frequency as 50 Hz or 60 Hz.
4. `#define BUSCLK 4000000`
...sets the internal bus frequency to 4 MHz.
5. `#define BUSCLKX2 8000000`
...set according to the internal bus frequency (BUSCLKX2=2*BUSCLK).
6. `#define TIMPRSC 2`
...sets BUSCLK/4 as a TIM clock source.
7. `#define PWM_MODULUS 100 /*see DLB_setup.xls */`
...represents the number of possible PWM duty cycles from 0% to 100% duty cycle.
8. `#define PWM_RELOADCYCLES 4 /*see DLB_setup.xls */`
...defines that PWM values are reloaded every 4th PWM cycle.
9. `#define PWM_RELOADS 100 /*see DLB_setup.xls */`
...represents the PWM reload period.
10. `#define PWM_PRESCALER 1 /*see DLB_setup.xls */`
...sets BUSCLK as a PWM clock frequency.
11. `#define PWM_START_POINTER 97`
...represents a start pointer to a value in table bSinTab[].
12. `#define DUTY_CYCLE_MAX 99`
...represents a maximum allowed duty cycle value according input voltage and frequency.
13. `#define HRP_SCALINGFACTOR 32 /*see DLB_setup.xls */`
...sets the scaling factor for the HRP.
14. `#define HRPTB_H 0X00 /*see DLB_setup.xls */`
...represents the HRP time base high byte.
15. `#define HRPTB_L 0X43 /*see DLB_setup.xls */`
...represents the HRP time base low byte.
16. `#define HRP_DEADTIME 0X08 /*see DLB_setup.xls */`
...defines the HRP deadtime.
17. `#define MAX_HRP_FREQ 120 /*see DLB_setup.xls */`
...defines the maximum HRP frequency in kHz.
18. `#define MAX_HRP_FREQ_TIME 20`
...defines the time spent at maximum HRP frequency in ms.
19. `#define MIN_HRP_FREQ 40 /*see DLB_setup.xls */`
...defines the minimum HRP frequency in kHz.
20. `#define PREHEAT_FREQ 86`
...defines the preheat HRP frequency in kHz.
21. `#define PREHEAT_TIME 900`
...defines the time spent at preheat HRP frequency in ms.

Software Design

22. `#define MIN_IGNITION_FREQ 45`
...defines the minimum HRP frequency in kHz.
23. `#define MAX2PREHEAT_RAMP 100`
...represents the number of frequency steps between the maximum HRP frequency and the preheat HRP frequency.
24. `#define IGNITION_RAMP 2000`
...represents the number of frequency steps between preheat HRP frequency and ignition HRP frequency.
25. `#define MIN_RUN_HRP_FREQ 50 /*see DLB_setup.xls */`
...defines the minimum HRP frequency in kHz during run mode.
26. `#define MAX_RUN_HRP_FREQ 100 /*see DLB_setup.xls */`
...defines the maximum HRP frequency in kHz during run mode.
27. `#define TUBE_CURR_MIN 10 /*see DLB_setup.xls */`
...represents the minimum tube current.
28. `#define TUBE_CURR_MAX 245 /*see DLB_setup.xls */`
...represents the maximum tube current.
29. `#define CURRFLT_MS 100`
...sets the zero current checking interval in ms.
30. `#define CURRFLT_CNT 3`
...represents the number of fault states during run mode.
31. `#define INGITION_CNT 3`
...represents the number of fault states during tube ignition.
32. `#define ADDMININTERVAL 100`
...represents the interval of dimming value measurement in ms.
33. `#define UC_REQUIRED_AN 390L`
...represents the required DC-bus voltage in V.
34. `#define UC_ALLOWED_MIN_AN 290L`
...represents the minimum allowed DC-bus voltage in V.
35. `#define UC_ALLOWED_MAX_AN 450L`
...defines the maximum allowed DC-bus voltage in V.
36. `#define UC_MAX_VAL_AN 458L`
...represents the maximum value of the DC-bus voltage in V.
37. `#define UC_START_PREHEAT_AN 370L`
...represents the preheat DC-bus voltage in V.
38. `#define UC_START_CYCLES_MAX 50`
...represents the interval in ms in which the DC-bus voltage must reach the required value.
39. `#define UC_START_RAMP_STEPS 30`
...represents the number of steps needed to reach the DC-bus required value from the zero value.
40. `#define PI_KP_START 10`
...represents the proportional gain of the PI PFC stage regulator in the start phase.
41. `#define PI_KI_START 3`
...represents the integral gain of the PI PFC stage regulator in the start phase.
42. `#define PI_KP_RUN 2`
...represents the proportional gain of the PI PFC stage regulator in run mode.
43. `#define PI_KI_RUN 1`

- ...represents the integral gain of the PI PFC stage regulator in run mode.
44. **#define PI_SCALE 0**
...represents the scaling factor of the PI PFC stage regulator (2^{scale}).
45. **#define PI_MIN_VAL 0**
...represents the minimum value of the PI PFC stage regulator output.
46. **#define PI_MAX_VAL 255**
...represents the maximum value of the PI PFC stage regulator output.
47. **#define PI_KP_RUNI 2**
...represents the proportional gain of the PI ballast stage regulator in run mode.
48. **#define PI_KI_RUNI 1**
...represents the integral gain of the PI ballast stage regulator in run mode.
49. **#define PI_SCALEI 0**
...represents the scaling factor of the PI ballast stage regulator (2^{scale}).

5.6.2 System Constants and Variables

This section describes the external global variables and constants used in the program.

- extern tSW_FLAGS SW_FLAGS;**
 This variable represents auxiliary program control flags and is defined as:

```
typedef union uSW_FLAGS
{
    tU08byte;
    struct
    {
        tU08 pi_en      1;// - bit enables or disables PI PFC stage regulator calculation
        tU08 trim_comp_en  :1;// - bit enables or disables trimmable value of internal
        oscillator calculation
        tU08 f_1_ms:      1;// - bit represents if 1 ms time interval has gone
        tU08 pi_eni      :1;// - bit enables or disables PI ballast stage regulator calculation
        tU08:             4;// - the others five bits are not used
    }bit;
}tSW_FLAGS;
```
- extern tU08 pwm_sin_tab_pointer;**
 This variable acts as a pointer to a value in table bSinTab[].
- extern tU08 m_avg_Dim[8];**
 This buffer saves the last eight AD conversion values of the required dimming value, for moving average calculations.
- extern tU08 p_m_avg_Dim;**
 This variable acts as a pointer to a value in the m_avg_Dim[8] array.
- extern tU16 m_avg_sum_Dim;**
 This variable represents the sum of all values in the m_avg_Dim[8] array.
- extern tU08 act_Uc;**
 This variable represents the actual value of the DC-bus voltage.
- extern tU08 timelms;**
 This variable counts PWM interrupts. The variable is incremented at every PWM interrupt. It is used

for timing 1 ms intervals.

8. **extern tU08 curr_T1;**
This variable represents the current in tube 1.
9. **extern tU08 curr_T2;**
This variable represents the current in tube 2.
10. **extern tU08 avg_CurrentT1T2;**
This variable represents the average value of the tube currents.
11. **extern tU16 mscounter;**
This variable counts 1 ms intervals. It is incremented every 1 ms. It is used for application timing.
12. **extern tU08 sineGain;**
This variable represents the gain of the reference sine waveform.
13. **extern tU16 timCntVal;**
This variable represents an auxiliary variable used to get the timer value required to trim the internal oscillator to the reference frequency (frequency of mains * 2)
14. **extern tU08 aux;**
This variable represents an auxiliary variable.
15. **extern tU16 ramp;**
This variable represents an auxiliary variable (HRP frequency) for dimming by ramping.
16. **extern tU08 currFltCNT;**
This variable represents the number of fault states occurring during run mode.
17. **extern tU08 currFltMS;**
This variable counts the zero current checking interval. It is incremented every 1 ms.
18. **extern tU08 ignitFltCNT;**
This variable represents the number of fault states occurring during tube ignition.
19. **extern tU16 integralPortionK_1;**
This variable represents integral n-1 value of the PI PFC stage regulator.
20. **extern tU08 proportionalGain;**
This variable represents proportional gain of the PI PFC stage regulator.
21. **extern tU08 integralGain;**
This variable represents integral gain of the PI PFC stage regulator.
22. **extern tU08 uCreq;**
This variable represents the required value of the DC-bus voltage.
23. **extern tU16 integralPortionK_1I;**
This variable represents integral n-1 value of the PI ballast stage regulator.
24. **extern tU08 proportionalGainI;**
This variable represents proportional gain of the PI ballast stage regulator.
25. **extern tU08 integralGainI;**
This variable represents integral gain of the PI ballast stage regulator.
26. **extern tU08 req_Cur;**
This variable represents the actual value of the required dimming value.
27. **extern tU08 time500us;**
This variable counts PWM interrupts. The variable is incremented at every PWM interrupt. It is used for timing 500 us intervals.

Chapter 6

Demo Setup

WARNING

This circuit is powered directly from the mains voltage supply. It is dangerous to touch any part of the circuit. When working with such circuits, do not connect any scope or development system without using an isolation transformer.

6.1 Hardware Setup

This section describes the setup and operation of the light ballast demo. Since the tubes are an integral part of the application, the whole demo system is considered. A photograph of the demo is shown in [Figure 1-1](#). No hardware setup is required to run the application. If you wish to debug the application using Monitor Mode, you must take apart the plexi glass, disconnect the light ballast from the mains supply, and connect the Monitor Mode connector to header JP5. In this case the light ballast must be supplied with a DC-bus voltage.

NOTE

The dimming level potentiometer must be set to the correct position for entry to Monitor Mode (pin PTA1 must be at logic level 1).

The dimming level potentiometer is connected to the JP2 header.

6.2 Software Setup

6.2.1 Required Software Tools

Metrowerks CodeWarrior for MC68HC08 microcontrollers version 3.0, or later, is required for developing the application.

6.2.2 Building and Uploading the Application

The application software is delivered as DLB-LB8-001.mcp project file (see Reference [5]) with C-sources and header files. To build the application software, open the **DLB-LB8-001.mcp** project file. Set definition lines at the beginning of “dlb_program_config.h” file as described in [5.6.1 System Setup Definitions](#). Then execute the *Make* command in the Project menu. This will build and link the application and all required Metrowerks libraries. Using Metrowerks CodeWarrior, the executable s19 file will be created. There are six possible versions of s19 file, which are also delivered as part of the software package.

The following SW versions are available:

- Hysteresis current control mode for 50 Hz— Hyst50Hz.s19
- Hysteresis current control mode for 60 Hz — Hyst60Hz.s19
- Discontinuous conduction mode for 50 Hz and for input voltage lower than half of DC-Bus voltage — DCM50HzL.s19

Demo Setup

- Discontinuous conduction mode for 50 Hz and for input voltage higher than half of DC-Bus voltage
— DCM50HzH.s19
- Discontinuous conduction mode for 60 Hz and for input voltage lower than half of DC-Bus voltage
— DCM60HzL.s19
- Discontinuous conduction mode for 60 Hz and for input voltage higher than half of DC-Bus voltage
— DCM60HzH.s19

For reprogramming the microcontroller you have the choice of serial bootloader or MON08 Cyclone. In the case of the serial bootloader, the bootloader must be programmed into the MCU before uploading the software application to the MCU by the MON08 Cyclone. After that, reprogramming the application is quicker than reprogramming by the MON08 Cyclone. For a detailed description of the bootloader functionality, refer to the application note in Reference [6]. For a detailed description of the MON08 Cyclone functionality, refer to the application note in Reference [2].

6.2.3 Executing the Application

The application is ready for operation when connected to a power supply.

6.2.4 Project Files

The dimmable light ballast application comprises the following files:

- ...DLB-LB8-001.mcp, application project file
- ...prp\prp\P&E_FCS_linker.prm, linker program file
- ...Sources\Start08.c, startup code for 68HC08 core
- ...Sources\MC68HC908LB8.h, MC68HC908LB8 registers and bits definitions header file
- ...Sources\MC68HC908LB8.c, MC68HC908LB8 register and bits definition file
- ...Sources\ram.h, RAM global variables declaration header file
- ...Sources\ram.c, RAM global variables definition file
- ...Sources\dlb_macros.h, application macros definition header file
- ...Sources\dlb_program_config.h, program and LB8 setup definitions header file
- ...Sources\dlb_constants.h, tables of constant values header file
- ...Sources\dlb_ISR_bodies.h, program interrupt service routines header file
- ...Sources\pi_types.h, definitions header file for PI regulators
- ...Sources\pi_sdkmath.asm, basic mathematical functions asm file
- ...Sources\pi_sdkmath.h, basic mathematical functions definition header file
- ...Sources\pi_sdkmath.c, basic mathematical functions file
- ...Sources\pi_controller.h, PI regulators header file
- ...Sources\pi_controller.c, PI regulators file
- ...Sources\code_fun.h, functions declaration header file
- ...Sources\code_fun.c, functions definition file
- ...Sources\main.c, main program

Appendix A. Schematics and Part List

A.1 Schematics

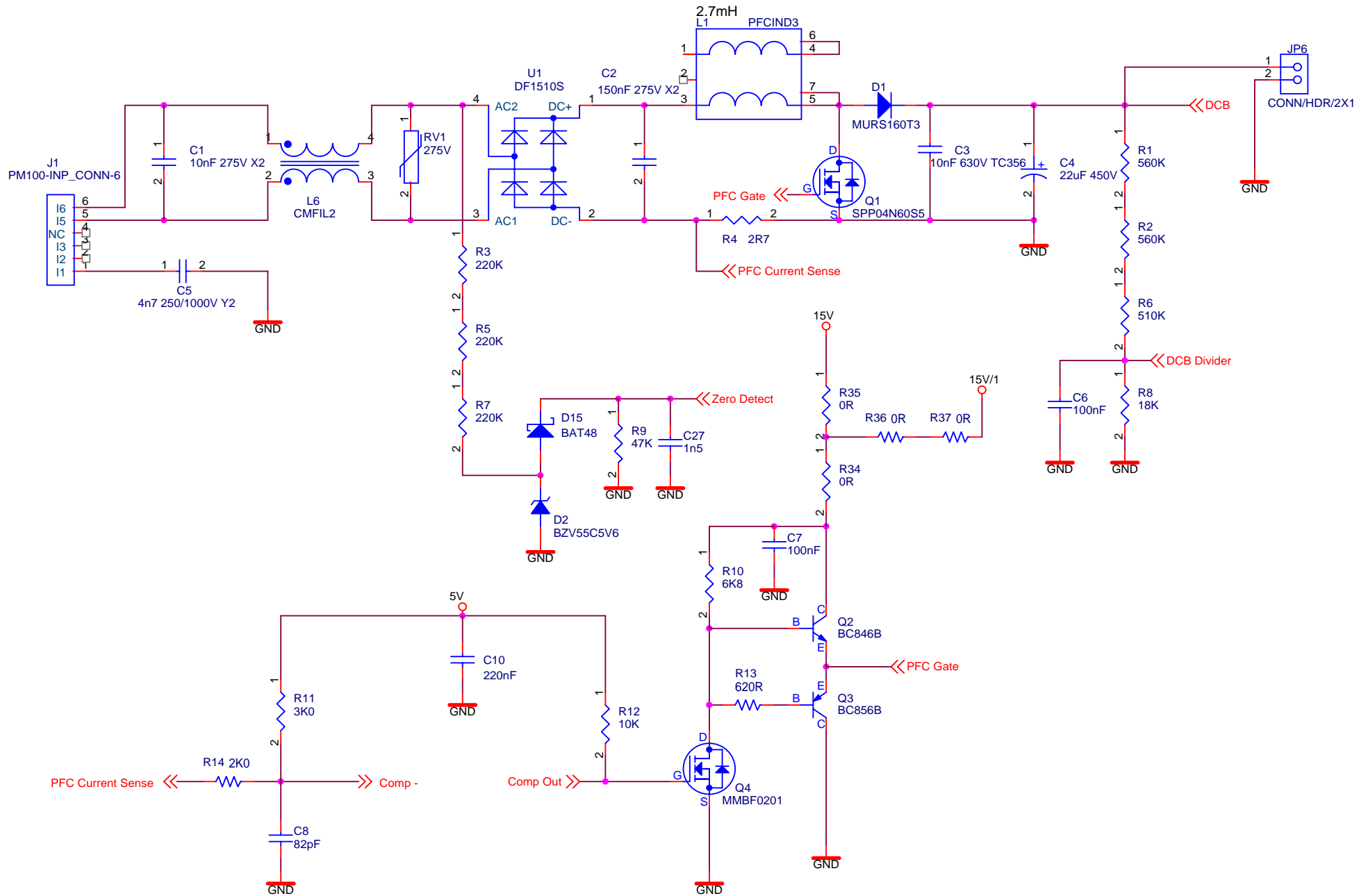

Figure A-1. Input and PFC for hysteresis current control mode HW variation

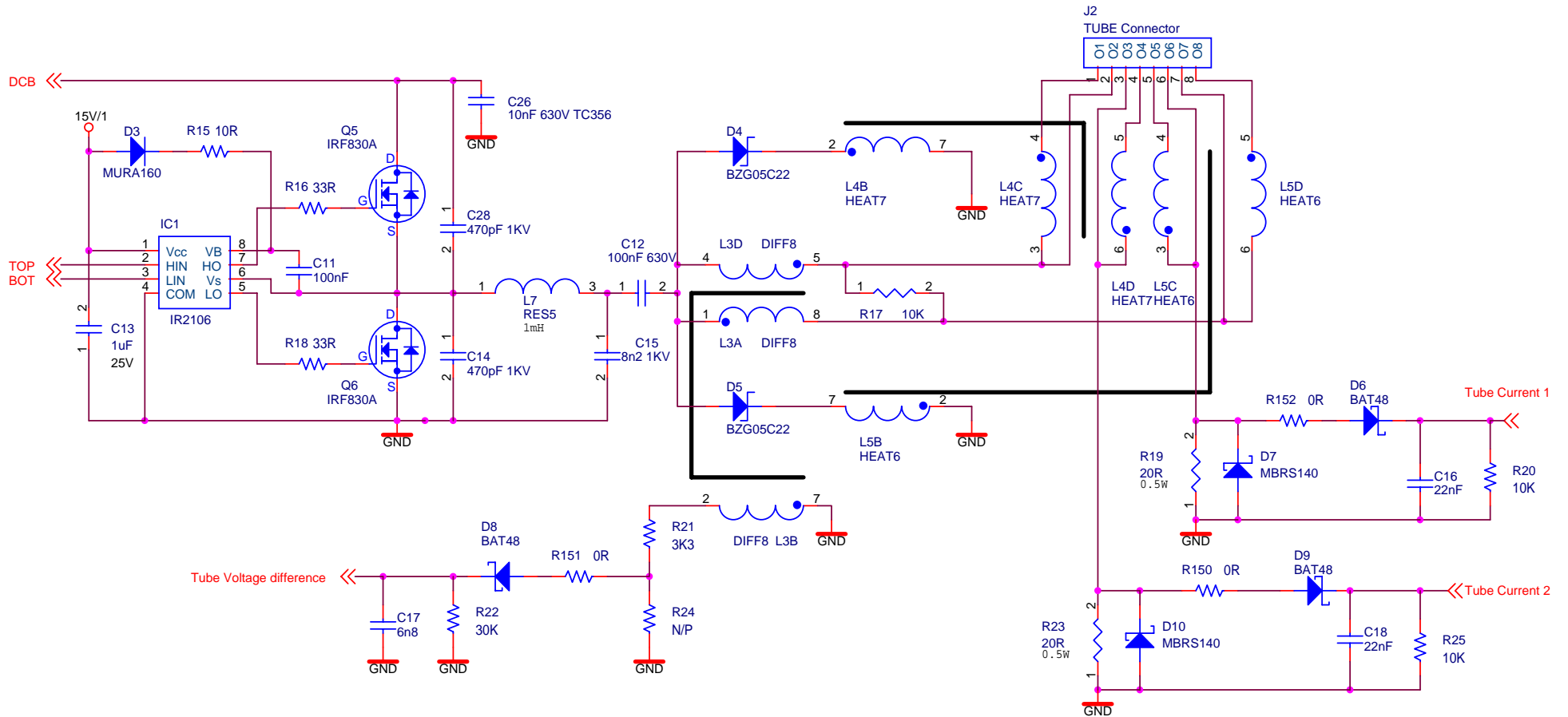

Figure A-3. Inverter

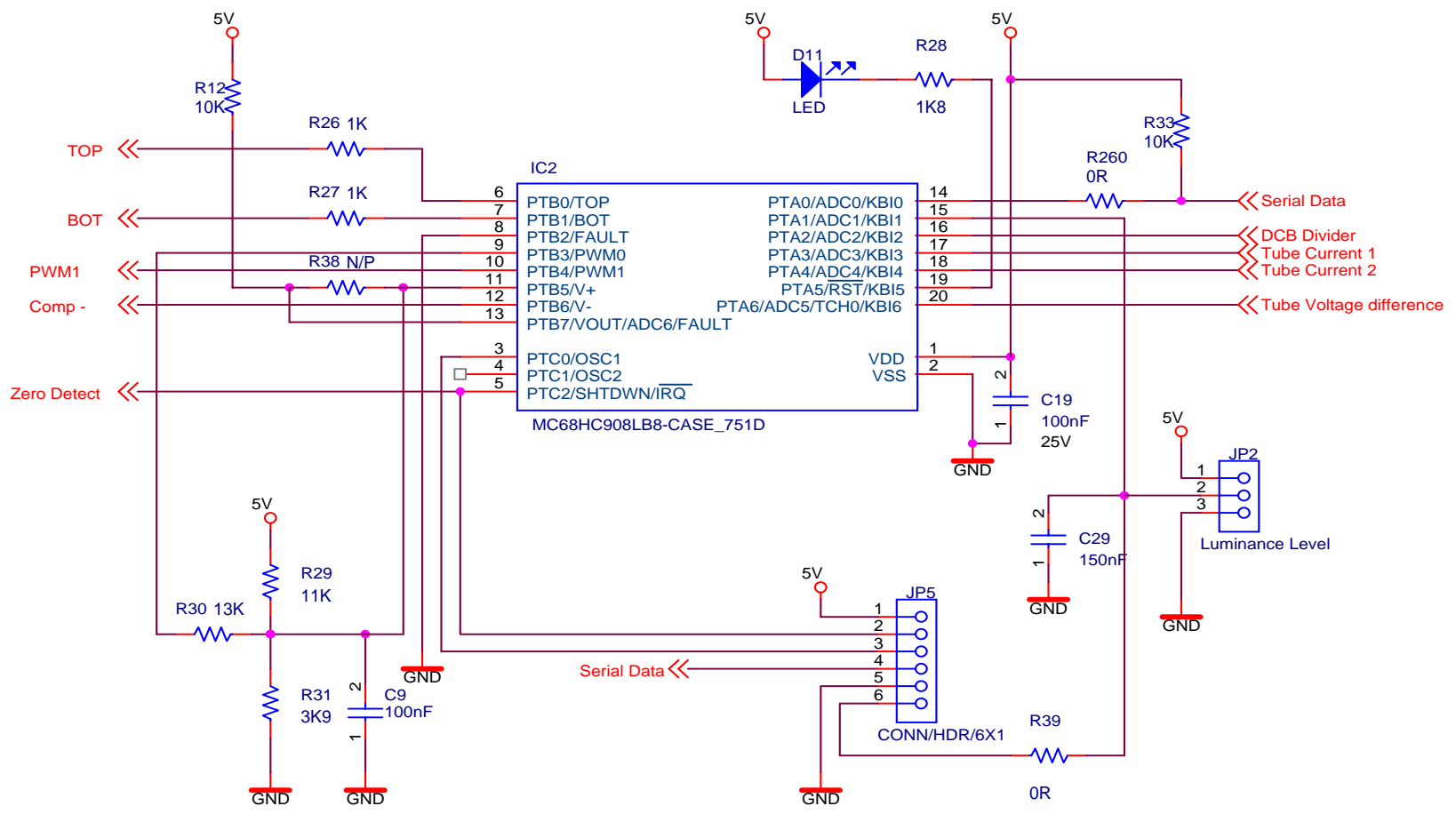

Figure A-5. Microcontroller for discontinuous conduction mode HW variation

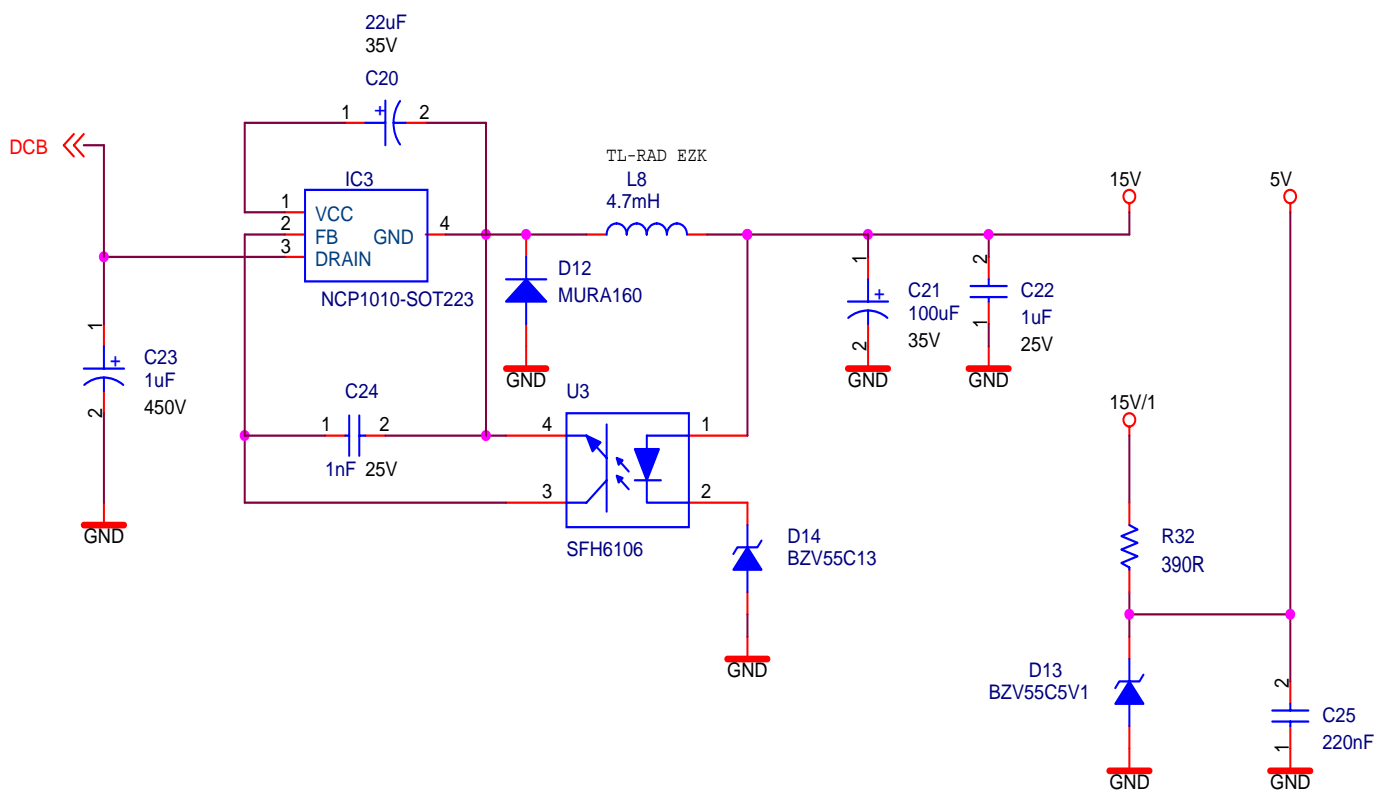

Figure A-6. Power supply

A.2 Parts List

Table A-1. Printed Circuit Board Parts List

DESIGNATORS	QUANTITY	DESCRIPTION	MANUFACTURER	PART NUMBER
C1	1	10nF/275V X2	ANY ACCEPTABLE	-
C2	1	150nF/275V X2	ANY ACCEPTABLE	-
C3,C26	2	10nF/630V TC356	ANY ACCEPTABLE	-
C4	1	22 μ F/450V	ANY ACCEPTABLE	-
C5	1	4.7nF 250/1000V	ANY ACCEPTABLE	-
C6,C7,C9,C11,C19	5	100nF ceramic 0805	ANY ACCEPTABLE	-
C8	1	82pF ceramic 0805	ANY ACCEPTABLE	-
C10,C25	2	220nF ceramic 0805	ANY ACCEPTABLE	-
C12	1	100nF/630V	ANY ACCEPTABLE	-
C13,C22	2	1 μ F	ANY ACCEPTABLE	-
C14,C28	2	470pF/1000V	ANY ACCEPTABLE	-
C15	1	8.2nF/1000V	ANY ACCEPTABLE	-
C16,C18	2	22nF ceramic 0805	ANY ACCEPTABLE	-
C17	1	6.8nF ceramic 0805	ANY ACCEPTABLE	-
C20	1	22 μ F/35V	ANY ACCEPTABLE	-
C21	1	100 μ F/35V	ANY ACCEPTABLE	-
C23	1	1 μ F/450V	ANY ACCEPTABLE	-
C24	1	1nF ceramic 0805	ANY ACCEPTABLE	-
C27	1	1.5nF ceramic 0805	ANY ACCEPTABLE	-
D1	1	1A/600V Ultrafast Rectifier/SMA	ON SEMICONDUCTOR	MURS160T3
D2	1	Zener	ANY ACCEPTABLE	BZV55C5V6
D3,D12	2	SMB	ON SEMICONDUCTOR	MURA160
D4,D5	2		VISHAY	BZG05C22
D6,D8,D9,D15	4		VISHAY	BAT48
D7,D10	2	SMB	ON SEMICONDUCTOR	MBRS140
D11	1	Red Display LED	ANY ACCEPTABLE	-
D13	1	Zener	ANY ACCEPTABLE	BZV55C5V1
D14	1	Zener	ANY ACCEPTABLE	BZV55C13
IC1	1	Power MOSFET Driver/SOIC8	INTERNATIONAL RECTIFIER	IR2106
IC2	1	Microcontroller/SOIC20	FREESCALE	MC68HC908LB8
IC3	1	SMPS Controller/SOT-223	ON SEMICONDUCTOR	NCP1010
JP2	1	HEADER 3X1	ANY ACCEPTABLE	-
JP5	1	HEADER 6X1	ANY ACCEPTABLE	-
J1	1	CONN-6	ANY ACCEPTABLE	-
J2	1	CONN-8	ANY ACCEPTABLE	-
L1	1	2.7mH	CUSTOMS	-
L3	1	L3A - 16.6mH, L3B - 9.5 μ H,L3C - 9.5 μ H,L3D - 16.6mH	CUSTOMS	-
L4	1	L4A - 80 μ H, L4B - 130 μ H,L4C - 150 μ H,L4D - 150 μ H	CUSTOMS	-
L5	1	L5A - 80 μ H, L5B - 130 μ H,L5C - 150 μ H,L5D - 150 μ H	CUSTOMS	-
L6	1	L6A - 90mH, L6B - 90mH	CUSTOMS	-

Table A-1. Printed Circuit Board Parts List (Continued)

DESIGNATORS	QUANTITY	DESCRIPTION	MANUFACTURER	PART NUMBER
L7	1	1mH	CUSTOMS	-
L8	1	4.7mH	ANY ACCEPTABLE	4.7mH - TL-RAD
Q1	1	Power MOSFET transistor TO-220	INTERNATIONAL RECTIFIER	SPP04N60S5
Q2	1	transistor SOT-23	FAIRCHILD	BC846B
Q3	1	transistor SOT-23	FAIRCHILD	BC856B
Q4	1	Power MOSFET transistor SOT-323	ON SEMICONDUCTOR	MMBF0201
Q5,Q6	2	Power MOSFET transistor TO-220	INTERNATIONAL RECTIFIER	IRF830A
RV1	1	275V varistor	ANY ACCEPTABLE	-
R1,R2	2	560k Ω resistor 1/10W 1% 0805	ANY ACCEPTABLE	-
R3,R5,R7	3	220k Ω resistor 1/10W 1% 0805	ANY ACCEPTABLE	-
R4	1	1.5 Ω /2.7 Ω resistor 2,5W 1% wirewound	ANY ACCEPTABLE	-
R6	1	510k Ω resistor 1/10W 1% 0805	ANY ACCEPTABLE	-
R8	1	18k Ω resistor 1/10W 1% 0805	ANY ACCEPTABLE	-
R9	1	47k Ω resistor 1/10W 1% 0805	ANY ACCEPTABLE	-
R10	1	6.8k Ω resistor 1/10W 1% 0805	ANY ACCEPTABLE	-
R11	1	3k Ω resistor 1/10W 1% 0805	ANY ACCEPTABLE	-
R12, R20,R25,R33	4	10k Ω resistor 1/10W 1% 0805	ANY ACCEPTABLE	-
R13	1	620 Ω resistor 1/10W 1% 0805	ANY ACCEPTABLE	-
R14	1	2k Ω resistor 6/10W 1% size 0207	ANY ACCEPTABLE	-
R15	1	10 Ω resistor 1/10W 1% 0805	ANY ACCEPTABLE	-
R16	1	33 Ω resistor 6/10W 1% size 0207	ANY ACCEPTABLE	-
R17		10k Ω resistor 6/10W 1% size 0207	ANY ACCEPTABLE	-
R18	1	33 Ω resistor 1/10W 1% 0805	ANY ACCEPTABLE	-
R19,R23	2	20 Ω resistor 6/10W 1% size 0207	ANY ACCEPTABLE	-
R21	1	3.3k Ω resistor 1/10W 1% 0805	ANY ACCEPTABLE	-
R22	1	30k Ω resistor 1/10W 1% 0805	ANY ACCEPTABLE	-
R24	1	N/P	ANY ACCEPTABLE	-
R26,R27	2	1k Ω resistor 1/10W 1% 0805	ANY ACCEPTABLE	-
R28	1	1.8k Ω resistor 1/10W 1% 0805	ANY ACCEPTABLE	-
R29	1	11k Ω resistor 1/10W 1% 0805	ANY ACCEPTABLE	-
R30	1	13k Ω resistor 1/10W 1% 0805	ANY ACCEPTABLE	-
R31	1	3.9k Ω resistor 1/10W 1% 0805	ANY ACCEPTABLE	-
R32	1	390 Ω resistor 1/10W 1% 0805	ANY ACCEPTABLE	-
R34,R150,R151, R152,R260	5	0 Ω resistor 1/4W 1% 1206	ANY ACCEPTABLE	-
R35,R36,R37,R39	4	0 Ω resistor 1/10W 1% 0805	ANY ACCEPTABLE	-
R38	1	N/P	ANY ACCEPTABLE	-
U1	1	Bridge Rectifier	VISHAY	DF1510S
U3	1	5.3kV Optocoupler	VISHAY	SFH6106

Appendix B. References

1. Electronic Lamp Ballast Design (AN1543/D), Motorola 1995
2. MON08 Cyclone User Manual, P&E Microcomputer Systems Inc. 2002
3. Opto-isolation Board User Manual, Freescale 2005
4. DLB_Setup.xls — HRP_Setup Excel sheet
5. DLB-LB8-001.mcp — project, debugger under CodeWarrior CW V3.0
6. Developer's Serial Bootloader for MC68HC08 (AN2295/D), Motorola 2002
7. MC68HC908LB8 data sheet, Freescale 2004
8. Freescale web page: <http://www.freescale.com>
9. CodeWarrior for Motorola HC08 manual version 3.0, Metrowerks 2002
10. Modular Evaluation Board System, MC68HC908LB8 Evaluation Board MMEVS
11. Modular Development System, MC68HC908LB8 MMDS Emulation Board

How to Reach Us:

Home Page:

www.freescale.com

E-mail:

support@freescale.com

USA/Europe or Locations Not Listed:

Freescale Semiconductor
Technical Information Center, CH370
1300 N. Alma School Road
Chandler, Arizona 85224
+1-800-521-6274 or +1-480-768-2130
support@freescale.com

Europe, Middle East, and Africa:

Freescale Halbleiter Deutschland GmbH
Technical Information Center
Schatzbogen 7
81829 Muenchen, Germany
+44 1296 380 456 (English)
+46 8 52200080 (English)
+49 89 92103 559 (German)
+33 1 69 35 48 48 (French)
support@freescale.com

Japan:

Freescale Semiconductor Japan Ltd.
Headquarters
ARCO Tower 15F
1-8-1, Shimo-Meguro, Meguro-ku,
Tokyo 153-0064, Japan
0120 191014 or +81 3 5437 9125
support.japan@freescale.com

Asia/Pacific:

Freescale Semiconductor Hong Kong Ltd.
Technical Information Center
2 Dai King Street
Tai Po Industrial Estate
Tai Po, N.T., Hong Kong
+800 2666 8080
support.asia@freescale.com

For Literature Requests Only:

Freescale Semiconductor Literature Distribution Center
P.O. Box 5405
Denver, Colorado 80217
1-800-441-2447 or 303-675-2140
Fax: 303-675-2150
LDCForFreescaleSemiconductor@hibbertgroup.com

Information in this document is provided solely to enable system and software implementers to use Freescale Semiconductor products. There are no express or implied copyright licenses granted hereunder to design or fabricate any integrated circuits or integrated circuits based on the information in this document.

Freescale Semiconductor reserves the right to make changes without further notice to any products herein. Freescale Semiconductor makes no warranty, representation or guarantee regarding the suitability of its products for any particular purpose, nor does Freescale Semiconductor assume any liability arising out of the application or use of any product or circuit, and specifically disclaims any and all liability, including without limitation consequential or incidental damages. "Typical" parameters that may be provided in Freescale Semiconductor data sheets and/or specifications can and do vary in different applications and actual performance may vary over time. All operating parameters, including "Typicals", must be validated for each customer application by customer's technical experts. Freescale Semiconductor does not convey any license under its patent rights nor the rights of others. Freescale Semiconductor products are not designed, intended, or authorized for use as components in systems intended for surgical implant into the body, or other applications intended to support or sustain life, or for any other application in which the failure of the Freescale Semiconductor product could create a situation where personal injury or death may occur. Should Buyer purchase or use Freescale Semiconductor products for any such unintended or unauthorized application, Buyer shall indemnify and hold Freescale Semiconductor and its officers, employees, subsidiaries, affiliates, and distributors harmless against all claims, costs, damages, and expenses, and reasonable attorney fees arising out of, directly or indirectly, any claim of personal injury or death associated with such unintended or unauthorized use, even if such claim alleges that Freescale Semiconductor was negligent regarding the design or manufacture of the part.



Freescale™ and the Freescale logo are trademarks of Freescale Semiconductor, Inc. All other product or service names are the property of their respective owners. P&E is a trademark of P&E Microcomputer Systems, Inc. CodeWarrior® is a registered trademark of MetroWerks, Inc., a wholly owned subsidiary of Freescale Semiconductor, Inc. MetroWerks® and the MetroWerks logo are registered trademarks of MetroWerks, Inc., a wholly owned subsidiary of Freescale Semiconductor, Inc. IR® is a registered trademark of International Rectifier Corporation.

© Freescale Semiconductor, Inc. 2005. All rights reserved.