

LMZ31710 Parallel User's Guide

The LMZ31710 device is a 2.95-V to 17-V input, 10-A output, Simple Switcher™ power module, which integrates the PWM controller, power MOSFETs, shielded inductor, and passives in a low-profile, QFN package. For applications requiring greater than 10 A, it is possible to parallel up to six LMZ31710 devices. This user's guide provides information on the correct usage of the test board and an explanation of the test points and jumpers on the board.

Contents

1	Description	2
2	Getting Started	2
3	Test Point Descriptions	4
4	Operation Notes	4
5	Current Limitations	5
6	Performance Data	6
7	2× Parallel Bill of Material	11
8	2× Parallel Schematic	12
9	4× Parallel Bill of Material	14
10	4× Parallel Schematic	15

List of Figures

1	2× LMZ31710 Test Board User Interface	2
2	4× LMZ31710 Test Board User Interface	3
3	Typical Current Balancing	5
4	UVLO Start-Up Waveform	6
5	UVLO Shutdown Waveform	6
6	INH Start-Up Waveform	7
7	INH Shutdown Waveform	7
8	Output Voltage Ripple – In-Phase	8
9	Output Voltage Ripple – 180° Out-of-Phase	8
10	Input Voltage Ripple – In-Phase	9
11	Input Voltage Ripple – 180° Out-of-Phase	9
12	Transient Response – 10-A Load Step (1 A/μs)	10

List of Tables

1	Terminal Block Numbering.....	3
2	Switching Frequency Range.....	5

1 Description

This test board features the LMZ31710 device configured for parallel operation. The test board operates over the entire input voltage range of the LMZ31710 device (2.95 to 17 V) with the option to select a split input power rail. The output voltage can be set to one of four popular values by using a configuration jumper (P4). This board can be configured to accept an external clock to set the switching frequency. Using a jumper, each paralleled LMZ31710 device can be configured to operate in phase with the master or 180° out-of-phase. Input and output capacitors are included on the board to accommodate the entire range of input and output voltages. Current monitoring test points are available to measure the current of each device. Monitoring test points are provided to allow measurement of efficiency, power dissipation, input ripple, output ripple, line and load regulation, and transient response. Control test points are provided to use the PWRGD, Inhibit/UVLO, synchronization (CLK_IN), and slow-start or tracking features.

2 Getting Started

Figure 1 and Figure 2 highlight the user interface items associated with both the 2x and 4x LMZ31710 parallel test board. The polarized PVIN power terminal blocks are used to connect to the host input supply, and the polarized VOUT power terminal blocks are used to connect to the load. These terminal blocks can accept up to 16 AWG wire. The polarized VBIAS terminal block is used along with the VIN SELECT jumper (P1) when optional split power supply operation is desired. Refer to the LMZ31710 device [datasheet](#) for further information on split power supply operation. Refer to Table 1 for terminal block numbering for either the 2x or 4x LMZ31710 parallel test board.

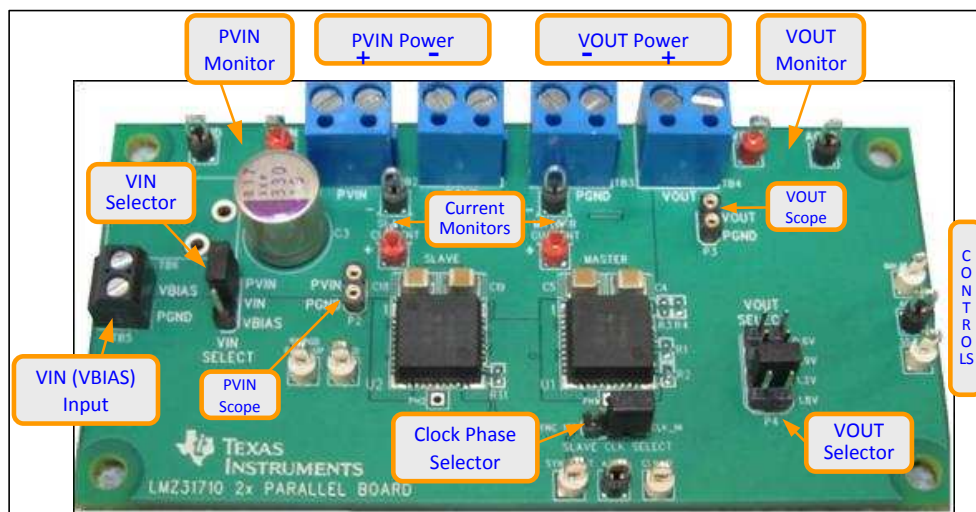

Figure 1. 2x LMZ31710 Test Board User Interface

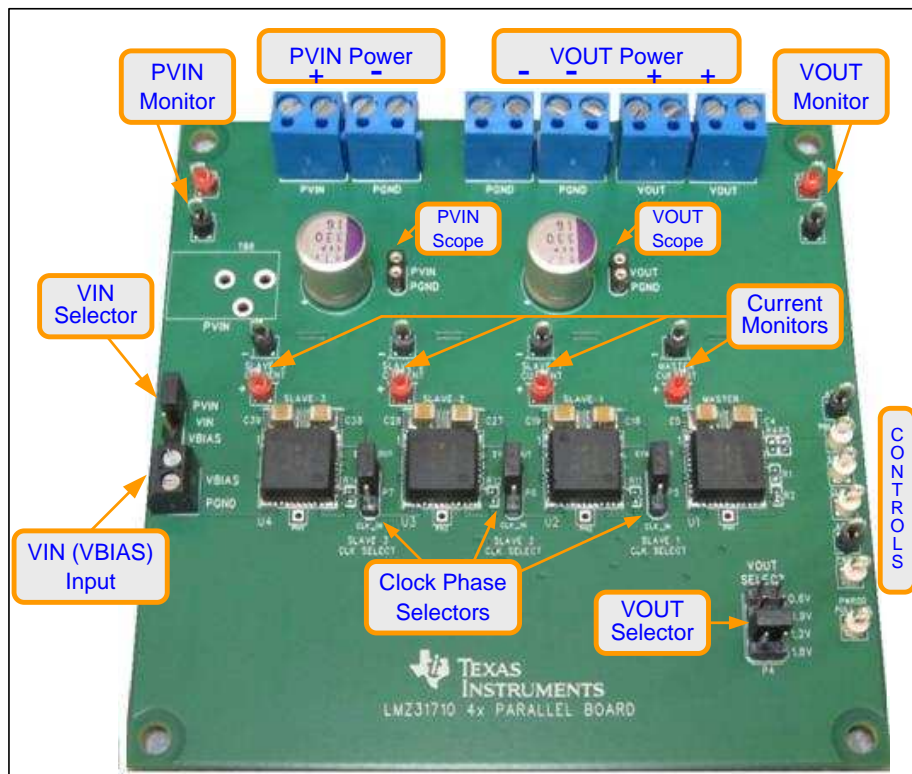

Figure 2. 4x LMZ31710 Test Board User Interface

Table 1. Terminal Block Numbering

Function	2x LMZ31710	4x LMZ31710
PVIN Power	TB1	TB1
PGND (Input)	TB2	TB2
PGND (Output)	TB3	TB3, TB4
VOUT Power	TB4	TB5, TB6
VBIAS Input	TB5	TB7

The PVIN Monitor and VOUT Monitor test points located near the power terminal blocks are intended as voltage monitoring points where digital voltmeters can connect to measure PVIN and VOUT.

CAUTION

Do not use these PVIN and VOUT monitoring test points as the input supply or output load connection points. The PCB traces connecting to these test points are not designed to support high currents. High currents may damage the PCB traces.

The PVIN Scope and VOUT Scope test points can be used to monitor PVIN and VOUT waveforms with an oscilloscope. These test points are intended for use with un-hooded scope probes outfitted with a low-inductance ground lead (ground spring) mounted to the scope barrel. The two sockets of each test point are on 0.1-inch centers. The scope probe tip should be connected to the socket labeled PVIN, or VOUT, and the scope ground lead should be connected to the socket labeled PGND.

The current monitor test points located above each LMZ31710 device are intended to be used with digital voltmeters to monitor the current across a 1-m Ω sense resistor located on the bottom of the board. The controls test points located on the perimeter of the board are made available to test the features of the device. Any external connections made to these test points should be referenced to an AGND test point. Refer to [Section 3](#) for more information on the individual control test points.

The VOUT SELECT jumper (P4) is provided for selecting the desired output voltage. Before applying power to the test board, ensure that the jumper is present and properly positioned for the intended output voltage. Always remove input power before changing the jumper settings.

3 Test Point Descriptions

Wire-loop test points and scope probe test points have been provided as convenient connection points for digital voltmeters (DVM) or oscilloscope probes to aid in the evaluation of the test board. A description of each test point follows:

Test Point	Description
AGND	Control and monitor grounds. Reference the DVMs and any signals associated with the control test points to any of the analog ground points.
CLK_IN	Connects to the RT/CLK pin of the LMZ31710 devices. An external clock signal can be applied to this point to synchronize the devices to an appropriate frequency.
INH/UVLO	Connect this point to control ground to inhibit the LMZ31710 devices. Allow this point to float to enable the device. An external resistor divider (R3 and R4) can be connected between this point, control ground, and PVIN to adjust the undervoltage lockout of the device.
PVIN	Input voltage monitor. Connect the DVM to this point for measuring efficiency.
PVIN Scope (P2)	Input voltage scope monitor. Connect an oscilloscope to this set of points to measure input ripple voltage.
PWRGD	Monitors the power good signal of the LMZ31710. This is an open drain signal that requires an external pull-up resistor if monitoring is desired. TI recommends a 10 to 100-k Ω pull-up resistor.
PWRGD PULL_UP	Power good pull-up voltage connection point. Connect an external voltage (< 6 V) to this pin to supply a voltage for the PWRGD signal. A 100-k Ω pull-up resistor is located on the bottom-side of the board.
SS/TR	Connects to the slow-start connection of the LMZ31710 devices. An external capacitor can be connected from this point to control ground to increase the slow-start time of the devices. This point can also be used as an input for tracking applications.
SYNC_OUT	This output provides a clock signal that is 180° out of phase with the PH node of the LMZ31710 device and can be used to synchronize other devices.
VOUT	Output voltage monitor. Connect DVM to this point for measuring efficiency, line regulation, and load regulation.
VOUT Scope (P3)	Output voltage scope monitor. Connect an oscilloscope to this set of points to measure output ripple voltage and transient response.

4 Operation Notes

To operate the test board using a single power supply, the VIN SELECT jumper (P1) must be in the default PVIN-VIN position as shown in [Figure 1](#) and [Figure 2](#). In this position, the PVIN and VIN pins of the LMZ31710 devices are connected together. When connected together the input voltage range is 4.5 to 17 V. Refer to the LMZ31710 [datasheet](#) for further information on the input voltage range, UVLO operation, and optional split power supply operation when using an external V_{bias} supply.

After a valid input voltage is present, the output voltage ramps to the selected value in approximately 1.2 ms. The soft-start time can be increased by adding a SS capacitor to the C12 position on the bottom of the test board. Refer to the LMZ31710 [datasheet](#) for further information on adjusting the soft-start time.

All LMZ31710 devices on the test board must be synchronized to the same frequency. This can be accomplished by either applying an external clock signal to the CLK_IN test point and running the clock to each device, or by setting the frequency of the master device using the RRT resistor (R2) and running the Sync_Out signal to the remaining slave devices. The Clock Phase Selector for each device is used to select either the external clock or the Sync_Out clock signal. The Sync_Out signal is a clock signal that is the same as the switching frequency, but is 180° out of phase. The test boards are set-up to operate at a free-running frequency of 300 kHz. To change the free-running switching frequency, the value of R2 can be changed according to the LMZ31710 [datasheet](#).

Table 2 lists the switching frequency ranges for each of the VOUT selections. Several factors such as duty cycle, minimum on-time, minimum off-time, and current limit influence selection of the switching frequency.

Table 2. Switching Frequency Range

VOUT (V)	Frequency Range	
	PVIN = 12 V	PVIN = 5 V
0.6	200 to 250 kHz	200 to 550 kHz
0.9	200 to 300 kHz	200 to 800 kHz
1.2	200 to 450 kHz	200 to 1000 kHz
1.8	300 to 600 kHz	300 to 1200 kHz

5 Current Limitations

When operating LMZ31710 devices in parallel, the maximum output current the solution can provide must be calculated using Equation 1. Due to internal variances between devices, the amount of output current must be de-rated to ensure none of the devices operate above the maximum output current of a single device (10 A). See Figure 3 for typical current balancing between four LMZ31710 devices.

$$I_{OUTmax} = 0.9 \times (n \times 10) \text{ (A)}$$

where n is the number of LMZ31710 devices being paralleled (1)

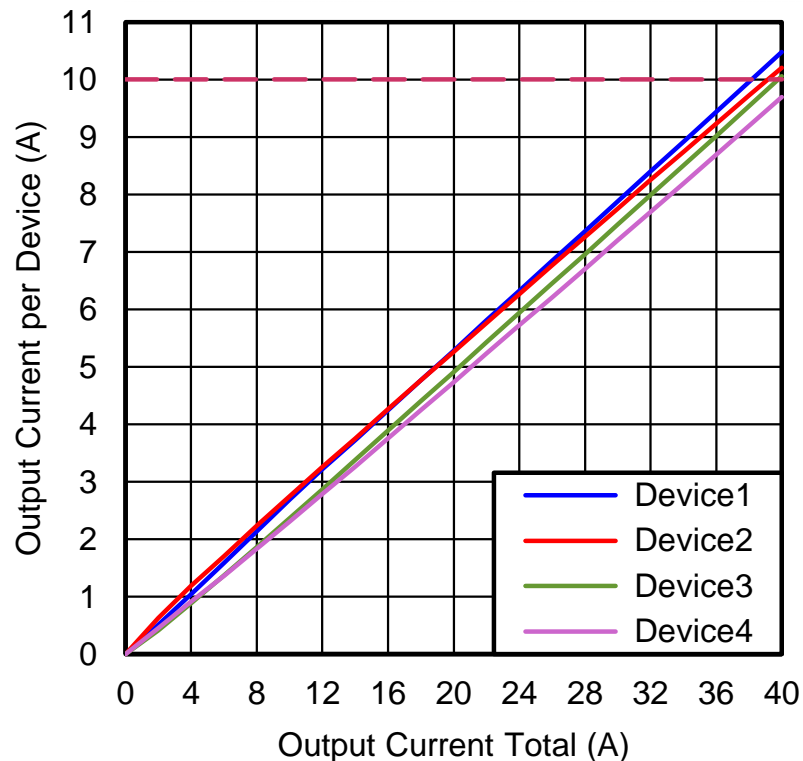

Figure 3. Typical Current Balancing

6 Performance Data

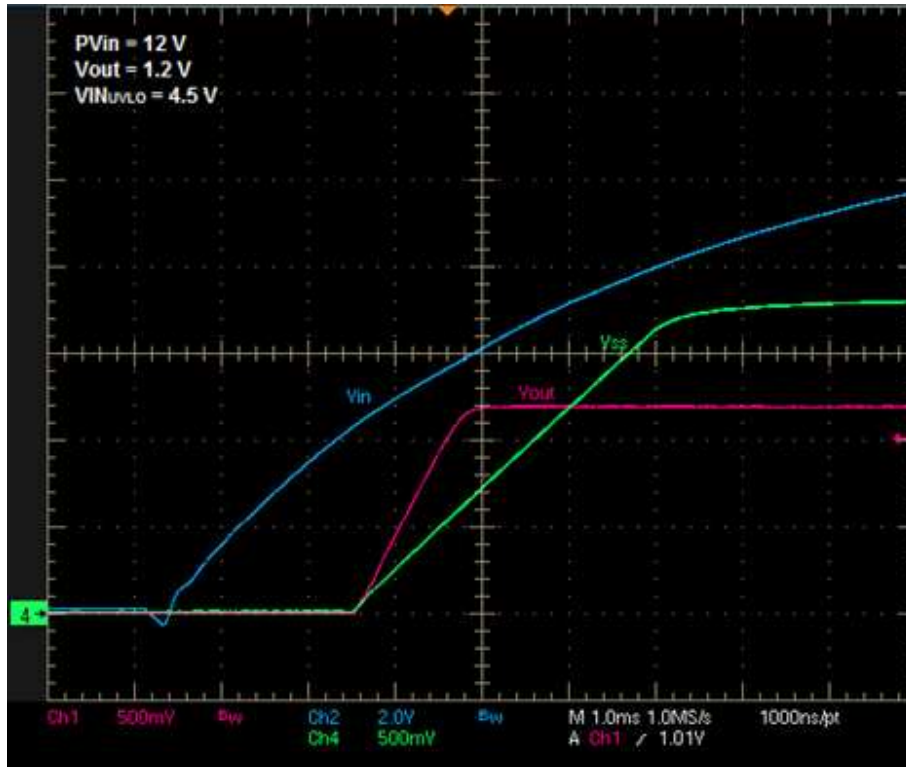

Figure 4. UVLO Start-Up Waveform



Figure 5. UVLO Shutdown Waveform



Figure 6. INH Start-Up Waveform



Figure 7. INH Shutdown Waveform

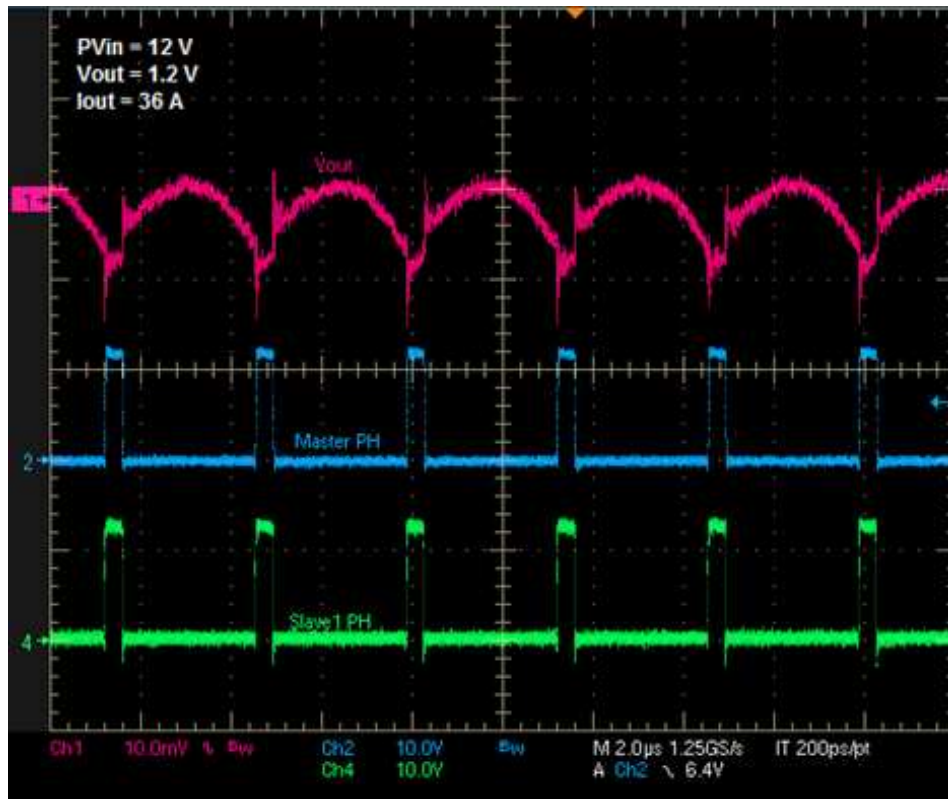

Figure 8. Output Voltage Ripple – In-Phase

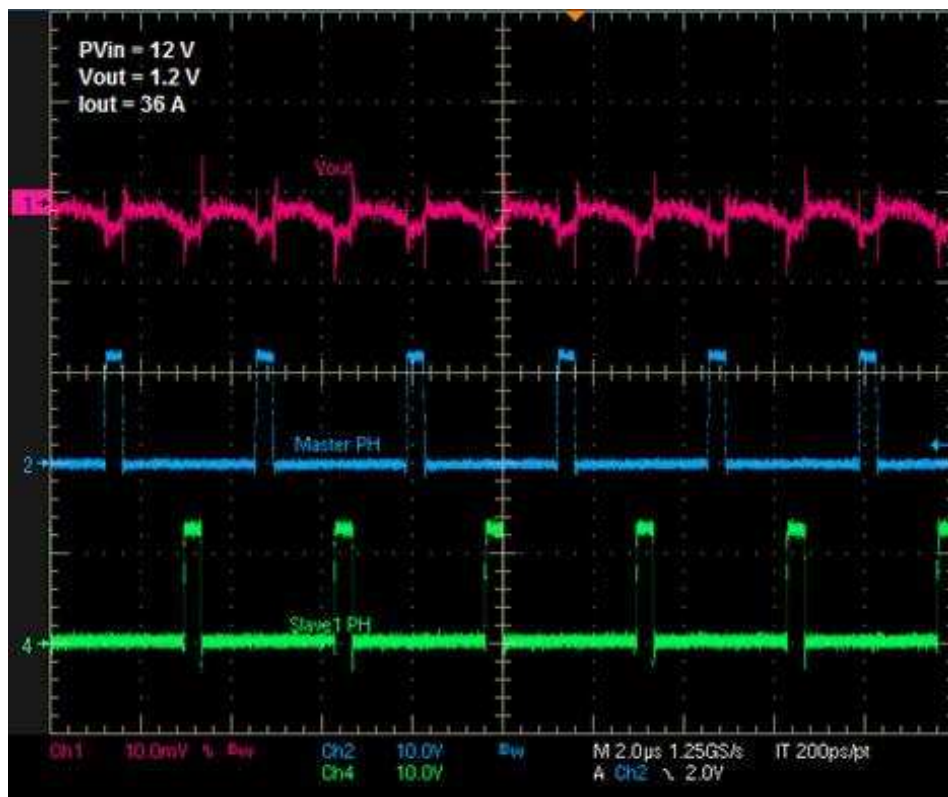

Figure 9. Output Voltage Ripple – 180° Out-of-Phase

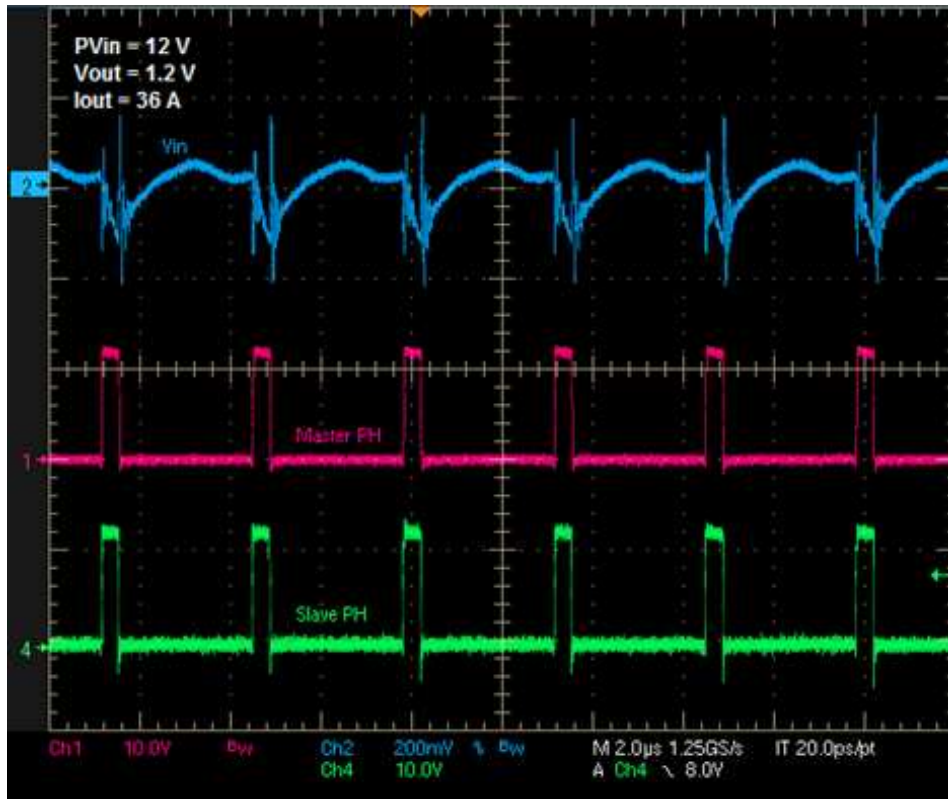

Figure 10. Input Voltage Ripple – In-Phase

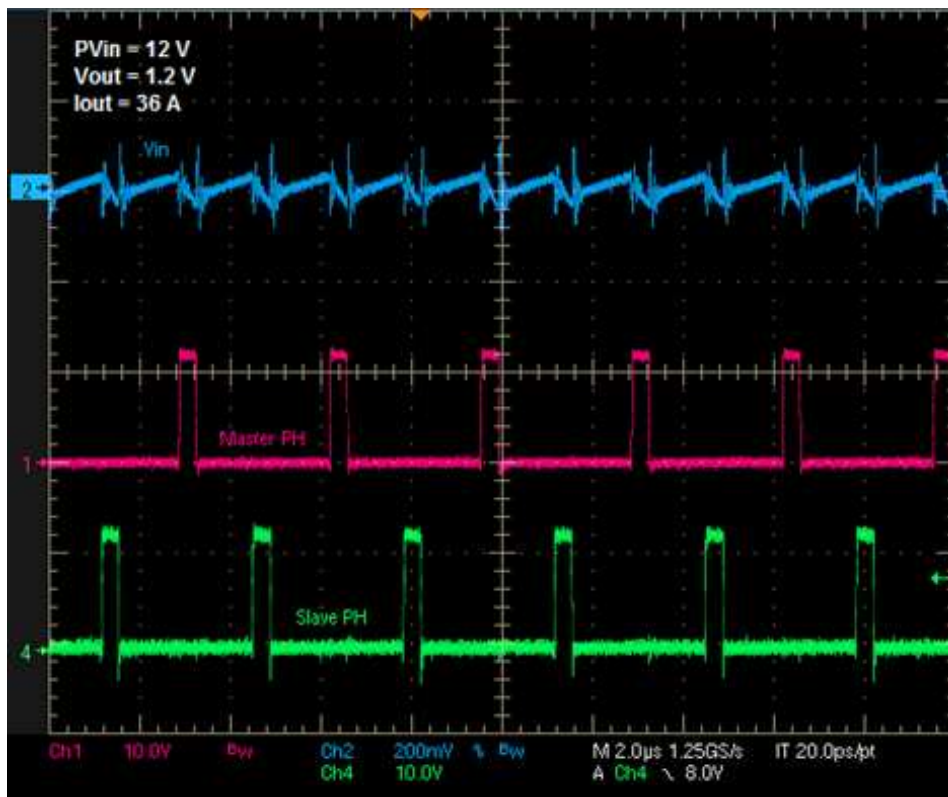

Figure 11. Input Voltage Ripple – 180° Out-of-Phase

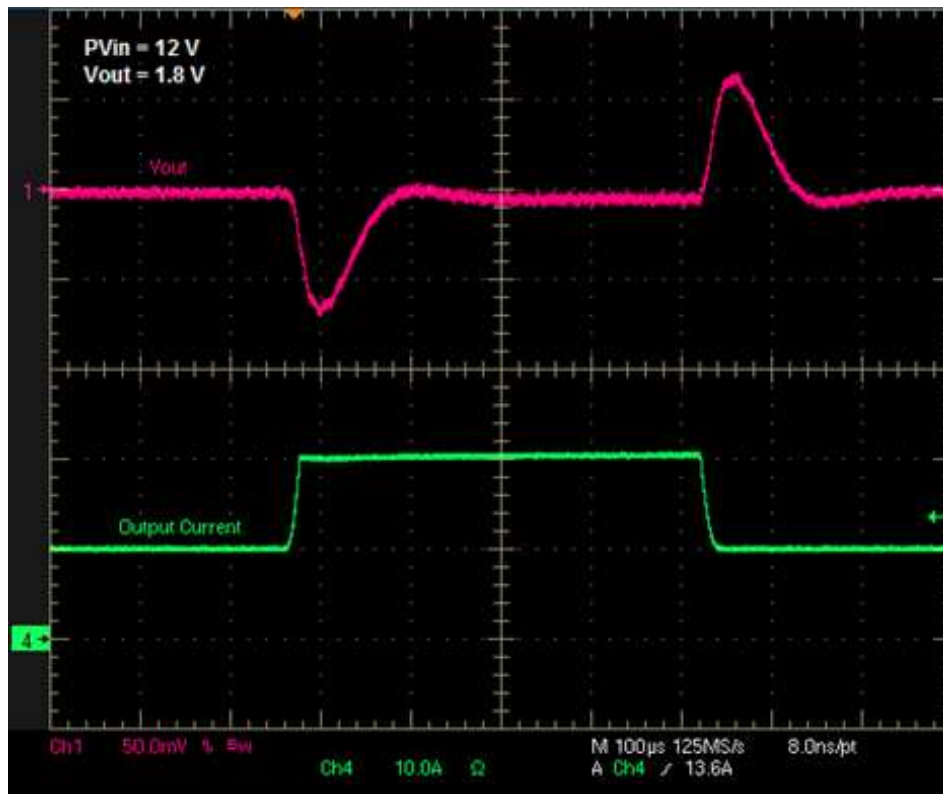
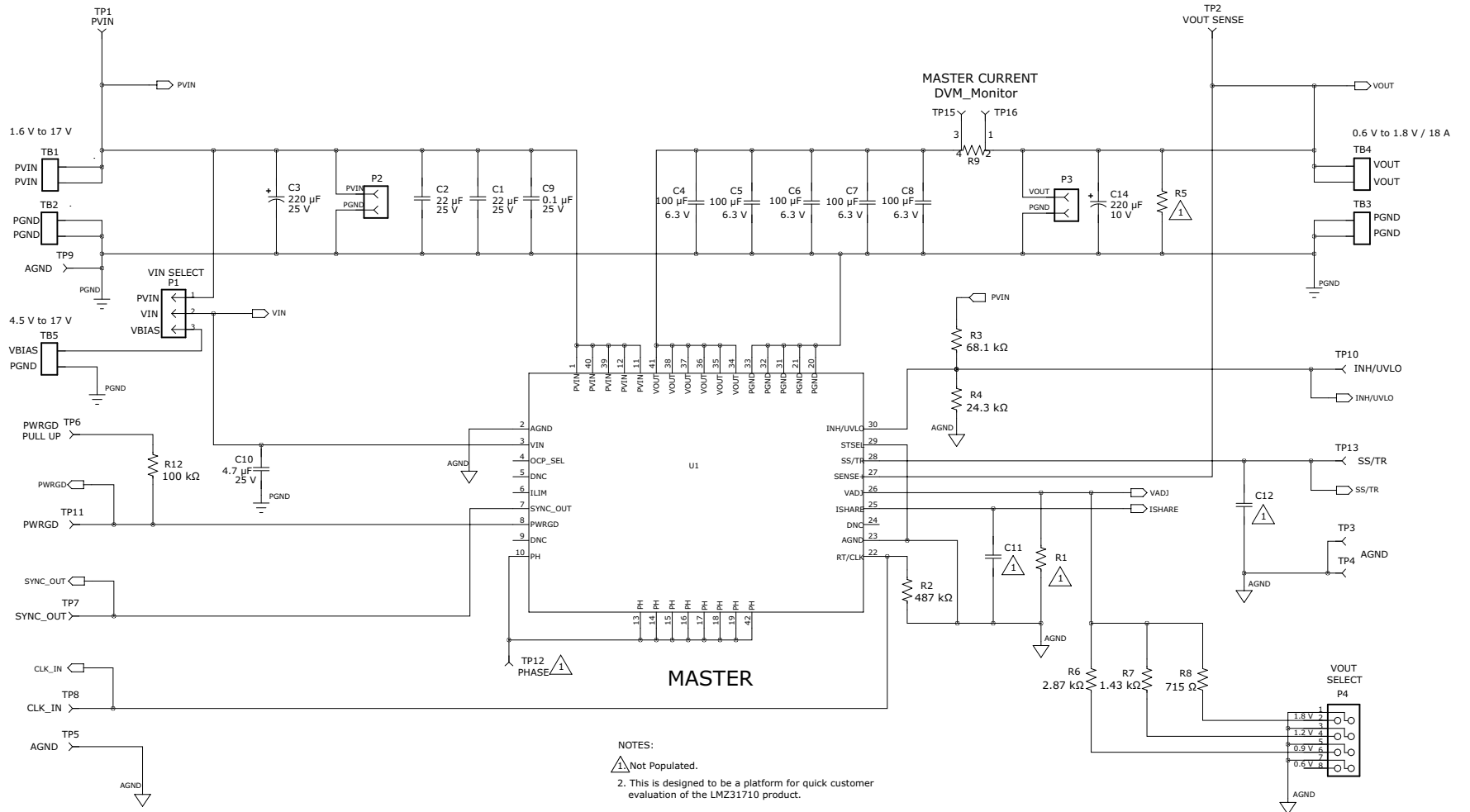

Figure 12. Transient Response – 10-A Load Step (1 A/µs)

7 2x Parallel Bill of Material

RefDes	Part Type	Value
C1, C2, C16, C17	C1210	22 μ F
C4, C5, C6, C7, C8, C18, C19, C20, C21, C22	C1210	100 μ F
C9, C24	C0805	0.1 μ F
C10, C25	C0805	4.7 μ F
C11, C12, C26	C0805	DNL
C3	CAP_ALUM_FC-A	220 μ F
C14, C23	CAP_POSCAP_D	220 μ F
P1, P5	MALE HEADER_1X3	PEC03SAAN
P2, P3	FEMALE HEADER_1X2	SOCKET 2 PIN
P4	MALE HEADER_2X4	PEC04DAAN
R1	R0402	NOT POPULATED
R2, R11	R0402	487k
R3	R0402	68.1k
R4	R0402	24.3k
R5	R0805	NOT POPULATED
R6	R0603_1%	2.87k
R7	R0603_1%	1.43k
R8	R0603_1%	715 Ω
R9, R10	57-WSL3637	R001R 1%
R12	R0603	100k
TB1, TB2, TB3, TB4	TBLK_15A_2X5.1MM	ED120/2DS
TB5	TBLK_6A_2X3.5MM	ED555/2DS
TB6	CONN_DC_PJ-102AH	PJ-102AH
TP6, TP7, TP8, TP10, TP11, TP13	TP-5012-WHITE	5012
TP1, TP2, TP15, TP17	TP-5010-RED	5010
TP3, TP4, TP5, TP9, TP16, TP18	TP-5011-BLACK	5011
TP12, TP14	TP-038	STD
U1, U2	LMZ31710RVQ	LMZ31710RVQ

8 2x Parallel Schematic



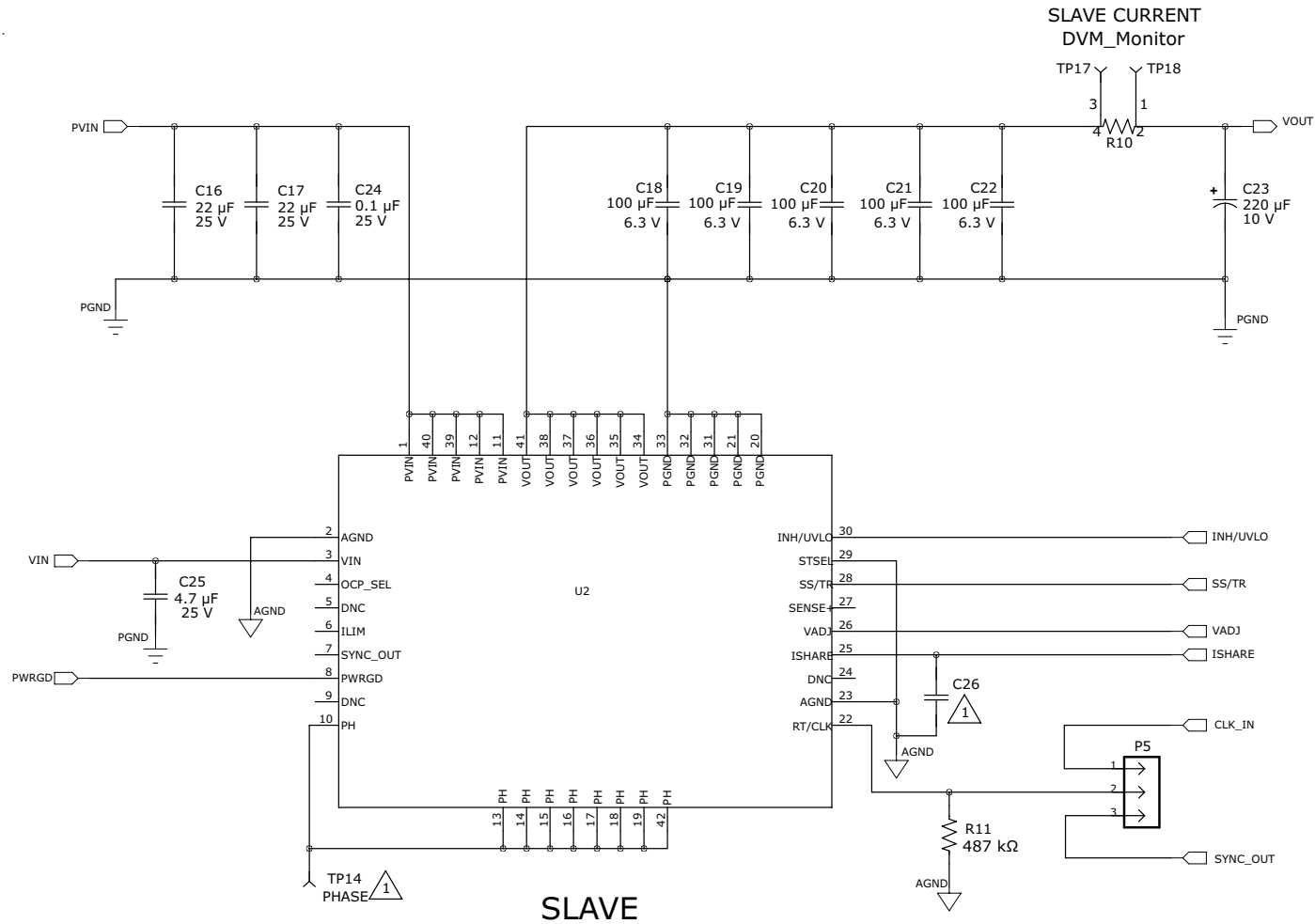

NOTES:

1 Not Populated.

2. This is designed to be a platform for quick customer evaluation of the LMZ31710 product.

9 4x Parallel Bill of Material

RefDes	Part Type	Value
C1, C2, C13, C15, C16, C17,C36, C37	C1210	22 μ F
C4, C5, C6, C7, C8, C18, C19, C20, C21, C22, C27, C28, C29, C34,C35, C38, C39, C40, C45, C46	C1210	100 μ F
C9, C24, C30, C41	C0805	0.1 μ F
C10, C25, C31, C42	C0805	4.7 μ F
C11, C12, C26, C33, C44	C0805	DNL
C3, C47	CAP_ALUM_FC-A	220 μ F
C14, C23, C32, C43	CAP_POSCAP_D	220 μ F
P1, P5, P6, P7	HEADER_1X3	PEC03SAAN
P2, P3	HEADER_1X2	NOT POPULATED
P4	HEADER_2X4	PEC04DAAN
R1	R0402	NOT POPULATED
R2, R11, R12, R14	R0402	487k
R3	R0402	68.1k
R4	R0402	24.3k
R5	R0805	NOT POPULATED
R6	R0603_1%	2.87k
R7	R0603_1%	1.43k
R8	R0603_1%	715 Ω
R9, R10, R13, R15	57-WSL3637	R001R 1%
R16	R0603	100k
TB1, TB2, TB3, TB4, TB5, TB6	TBLK_15A_2X5.1MM	ED120/2DS
TB7	TBLK_6A_2X3.5MM	ED555/2DS
TP1, TP2, TP15, TP17, TP19, TP23	TP-5010-RED	5010
TP3, TP4, TP5, TP9, TP16, TP18, TP20, TP25	TP-5011-BLACK	5011
TP7, TP8, TP10, TP11, TP13	TP-5012-WHITE	5012
TP6, TP12, TP14, TP22	TP-038	STD
U1, U2, U3, U4	LMZ31710RVQ	LMZ31710RVQ

10 4x Parallel Schematic

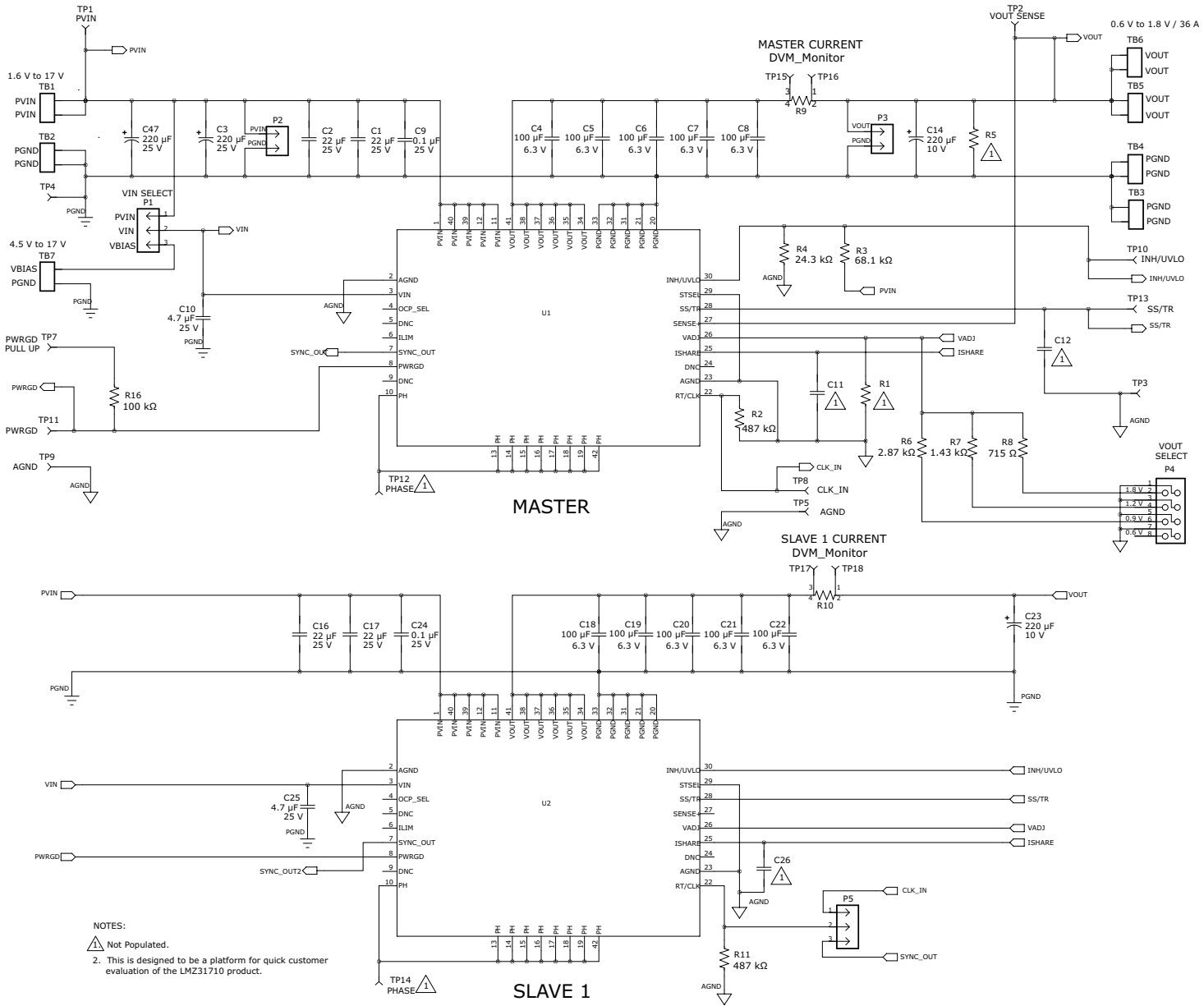

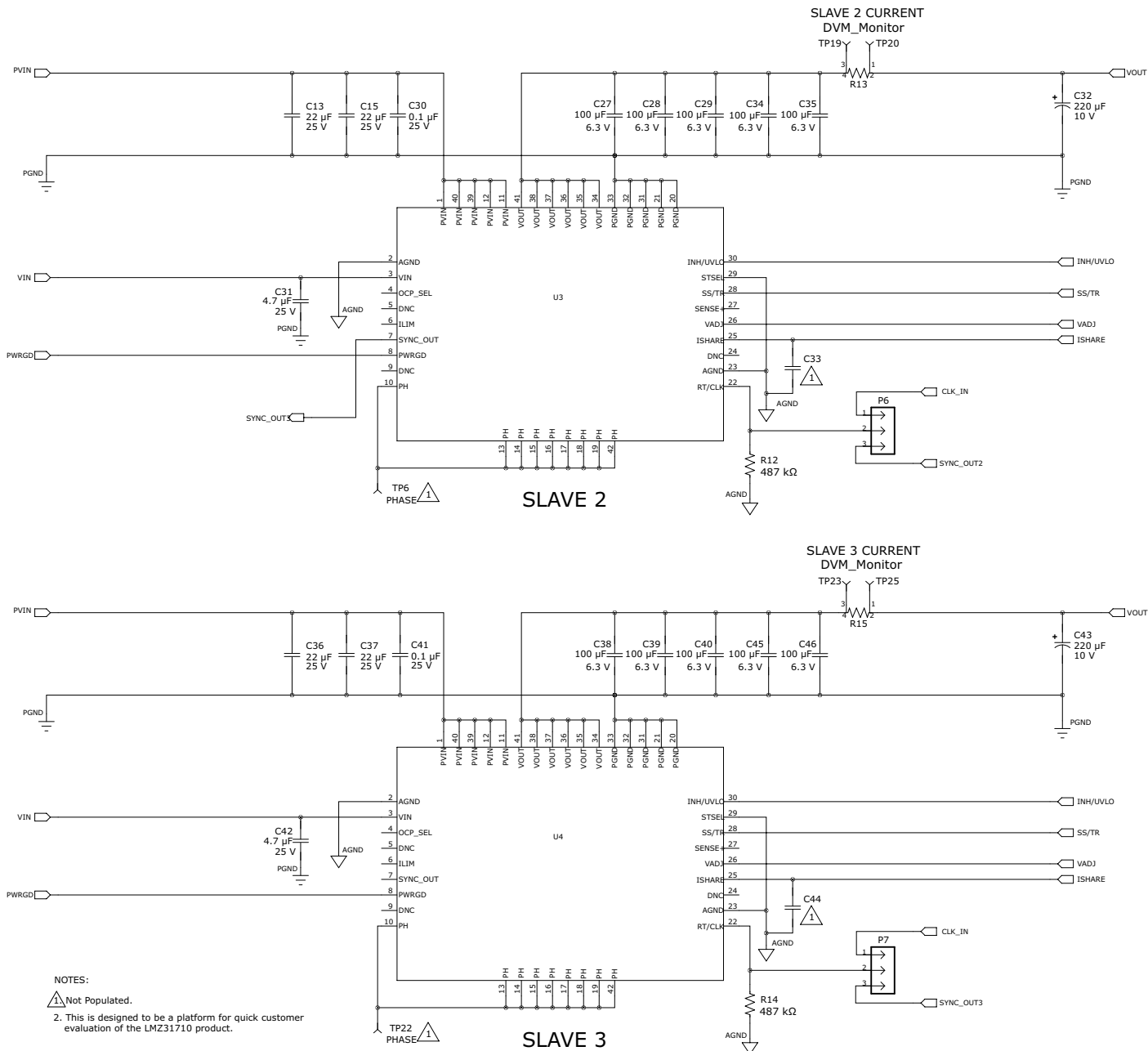

NOTES:
 1. Not Populated.
 2. This is designed to be a platform for quick customer evaluation of the LMZ31710 product.

Revision History

STANDARD TERMS AND CONDITIONS FOR EVALUATION MODULES

1. *Delivery:* TI delivers TI evaluation boards, kits, or modules, including any accompanying demonstration software, components, or documentation (collectively, an "EVM" or "EVMs") to the User ("User") in accordance with the terms and conditions set forth herein. Acceptance of the EVM is expressly subject to the following terms and conditions.
 - 1.1 EVMs are intended solely for product or software developers for use in a research and development setting to facilitate feasibility evaluation, experimentation, or scientific analysis of TI semiconductors products. EVMs have no direct function and are not finished products. EVMs shall not be directly or indirectly assembled as a part or subassembly in any finished product. For clarification, any software or software tools provided with the EVM ("Software") shall not be subject to the terms and conditions set forth herein but rather shall be subject to the applicable terms and conditions that accompany such Software
 - 1.2 EVMs are not intended for consumer or household use. EVMs may not be sold, sublicensed, leased, rented, loaned, assigned, or otherwise distributed for commercial purposes by Users, in whole or in part, or used in any finished product or production system.
2. *Limited Warranty and Related Remedies/Disclaimers:*
 - 2.1 These terms and conditions do not apply to Software. The warranty, if any, for Software is covered in the applicable Software License Agreement.
 - 2.2 TI warrants that the TI EVM will conform to TI's published specifications for ninety (90) days after the date TI delivers such EVM to User. Notwithstanding the foregoing, TI shall not be liable for any defects that are caused by neglect, misuse or mistreatment by an entity other than TI, including improper installation or testing, or for any EVMs that have been altered or modified in any way by an entity other than TI. Moreover, TI shall not be liable for any defects that result from User's design, specifications or instructions for such EVMs. Testing and other quality control techniques are used to the extent TI deems necessary or as mandated by government requirements. TI does not test all parameters of each EVM.
 - 2.3 If any EVM fails to conform to the warranty set forth above, TI's sole liability shall be at its option to repair or replace such EVM, or credit User's account for such EVM. TI's liability under this warranty shall be limited to EVMs that are returned during the warranty period to the address designated by TI and that are determined by TI not to conform to such warranty. If TI elects to repair or replace such EVM, TI shall have a reasonable time to repair such EVM or provide replacements. Repaired EVMs shall be warranted for the remainder of the original warranty period. Replaced EVMs shall be warranted for a new full ninety (90) day warranty period.
3. *Regulatory Notices:*
 - 3.1 *United States*
 - 3.1.1 *Notice applicable to EVMs not FCC-Approved:*

This kit is designed to allow product developers to evaluate electronic components, circuitry, or software associated with the kit to determine whether to incorporate such items in a finished product and software developers to write software applications for use with the end product. This kit is not a finished product and when assembled may not be resold or otherwise marketed unless all required FCC equipment authorizations are first obtained. Operation is subject to the condition that this product not cause harmful interference to licensed radio stations and that this product accept harmful interference. Unless the assembled kit is designed to operate under part 15, part 18 or part 95 of this chapter, the operator of the kit must operate under the authority of an FCC license holder or must secure an experimental authorization under part 5 of this chapter.
 - 3.1.2 *For EVMs annotated as FCC – FEDERAL COMMUNICATIONS COMMISSION Part 15 Compliant:*

CAUTION

This device complies with part 15 of the FCC Rules. Operation is subject to the following two conditions: (1) This device may not cause harmful interference, and (2) this device must accept any interference received, including interference that may cause undesired operation.

Changes or modifications not expressly approved by the party responsible for compliance could void the user's authority to operate the equipment.

FCC Interference Statement for Class A EVM devices

NOTE: This equipment has been tested and found to comply with the limits for a Class A digital device, pursuant to part 15 of the FCC Rules. These limits are designed to provide reasonable protection against harmful interference when the equipment is operated in a commercial environment. This equipment generates, uses, and can radiate radio frequency energy and, if not installed and used in accordance with the instruction manual, may cause harmful interference to radio communications. Operation of this equipment in a residential area is likely to cause harmful interference in which case the user will be required to correct the interference at his own expense.

FCC Interference Statement for Class B EVM devices

NOTE: This equipment has been tested and found to comply with the limits for a Class B digital device, pursuant to part 15 of the FCC Rules. These limits are designed to provide reasonable protection against harmful interference in a residential installation. This equipment generates, uses and can radiate radio frequency energy and, if not installed and used in accordance with the instructions, may cause harmful interference to radio communications. However, there is no guarantee that interference will not occur in a particular installation. If this equipment does cause harmful interference to radio or television reception, which can be determined by turning the equipment off and on, the user is encouraged to try to correct the interference by one or more of the following measures:

- Reorient or relocate the receiving antenna.
- Increase the separation between the equipment and receiver.
- Connect the equipment into an outlet on a circuit different from that to which the receiver is connected.
- Consult the dealer or an experienced radio/TV technician for help.

3.2 Canada

3.2.1 For EVMs issued with an Industry Canada Certificate of Conformance to RSS-210

Concerning EVMs Including Radio Transmitters:

This device complies with Industry Canada license-exempt RSS standard(s). Operation is subject to the following two conditions: (1) this device may not cause interference, and (2) this device must accept any interference, including interference that may cause undesired operation of the device.

Concernant les EVMs avec appareils radio:

Le présent appareil est conforme aux CNR d'Industrie Canada applicables aux appareils radio exempts de licence. L'exploitation est autorisée aux deux conditions suivantes: (1) l'appareil ne doit pas produire de brouillage, et (2) l'utilisateur de l'appareil doit accepter tout brouillage radioélectrique subi, même si le brouillage est susceptible d'en compromettre le fonctionnement.

Concerning EVMs Including Detachable Antennas:

Under Industry Canada regulations, this radio transmitter may only operate using an antenna of a type and maximum (or lesser) gain approved for the transmitter by Industry Canada. To reduce potential radio interference to other users, the antenna type and its gain should be so chosen that the equivalent isotropically radiated power (e.i.r.p.) is not more than that necessary for successful communication. This radio transmitter has been approved by Industry Canada to operate with the antenna types listed in the user guide with the maximum permissible gain and required antenna impedance for each antenna type indicated. Antenna types not included in this list, having a gain greater than the maximum gain indicated for that type, are strictly prohibited for use with this device.

Concernant les EVMs avec antennes détachables

Conformément à la réglementation d'Industrie Canada, le présent émetteur radio peut fonctionner avec une antenne d'un type et d'un gain maximal (ou inférieur) approuvé pour l'émetteur par Industrie Canada. Dans le but de réduire les risques de brouillage radioélectrique à l'intention des autres utilisateurs, il faut choisir le type d'antenne et son gain de sorte que la puissance isotrope rayonnée équivalente (p.i.r.e.) ne dépasse pas l'intensité nécessaire à l'établissement d'une communication satisfaisante. Le présent émetteur radio a été approuvé par Industrie Canada pour fonctionner avec les types d'antenne énumérés dans le manuel d'usage et ayant un gain admissible maximal et l'impédance requise pour chaque type d'antenne. Les types d'antenne non inclus dans cette liste, ou dont le gain est supérieur au gain maximal indiqué, sont strictement interdits pour l'exploitation de l'émetteur.

3.3 Japan

3.3.1 *Notice for EVMs delivered in Japan:* Please see http://www.tij.co.jp/lstds/ti_ja/general/eStore/notice_01.page 日本国内に輸入される評価用キット、ボードについては、次のところをご覧ください。
http://www.tij.co.jp/lstds/ti_ja/general/eStore/notice_01.page

3.3.2 *Notice for Users of EVMs Considered "Radio Frequency Products" in Japan:* EVMs entering Japan may not be certified by TI as conforming to Technical Regulations of Radio Law of Japan.

If User uses EVMs in Japan, not certified to Technical Regulations of Radio Law of Japan, User is required by Radio Law of Japan to follow the instructions below with respect to EVMs:

1. Use EVMs in a shielded room or any other test facility as defined in the notification #173 issued by Ministry of Internal Affairs and Communications on March 28, 2006, based on Sub-section 1.1 of Article 6 of the Ministry's Rule for Enforcement of Radio Law of Japan,
2. Use EVMs only after User obtains the license of Test Radio Station as provided in Radio Law of Japan with respect to EVMs, or
3. Use of EVMs only after User obtains the Technical Regulations Conformity Certification as provided in Radio Law of Japan with respect to EVMs. Also, do not transfer EVMs, unless User gives the same notice above to the transferee. Please note that if User does not follow the instructions above, User will be subject to penalties of Radio Law of Japan.

【無線電波を送信する製品の開発キットをお使いになる際の注意事項】 開発キットの中には技術基準適合証明を受けていないものがあります。技術適合証明を受けていないものご使用に際しては、電波法遵守のため、以下のいずれかの措置を取っていただく必要がありますのでご注意ください。

1. 電波法施行規則第6条第1項第1号に基づく平成18年3月28日総務省告示第173号で定められた電波暗室等の試験設備でご使用いただく。
2. 実験局の免許を取得後ご使用いただく。
3. 技術基準適合証明を取得後ご使用いただく。

なお、本製品は、上記の「ご使用にあたっての注意」を譲渡先、移転先に通知しない限り、譲渡、移転できないものとします。

上記を遵守頂けない場合は、電波法の罰則が適用される可能性があることをご留意ください。日本テキサス・インスツルメンツ株式会社
東京都新宿区西新宿 6 丁目 2 4 番 1 号
西新宿三井ビル

3.3.3 *Notice for EVMs for Power Line Communication:* Please see http://www.tij.co.jp/llds/ti_ja/general/eStore/notice_02.page
電力線搬送波通信についての開発キットをお使いになる際の注意事項については、次のところをご覧ください。http://www.tij.co.jp/llds/ti_ja/general/eStore/notice_02.page

4 *EVM Use Restrictions and Warnings:*

4.1 EVMS ARE NOT FOR USE IN FUNCTIONAL SAFETY AND/OR SAFETY CRITICAL EVALUATIONS, INCLUDING BUT NOT LIMITED TO EVALUATIONS OF LIFE SUPPORT APPLICATIONS.

4.2 User must read and apply the user guide and other available documentation provided by TI regarding the EVM prior to handling or using the EVM, including without limitation any warning or restriction notices. The notices contain important safety information related to, for example, temperatures and voltages.

4.3 *Safety-Related Warnings and Restrictions:*

4.3.1 User shall operate the EVM within TI's recommended specifications and environmental considerations stated in the user guide, other available documentation provided by TI, and any other applicable requirements and employ reasonable and customary safeguards. Exceeding the specified performance ratings and specifications (including but not limited to input and output voltage, current, power, and environmental ranges) for the EVM may cause personal injury or death, or property damage. If there are questions concerning performance ratings and specifications, User should contact a TI field representative prior to connecting interface electronics including input power and intended loads. Any loads applied outside of the specified output range may also result in unintended and/or inaccurate operation and/or possible permanent damage to the EVM and/or interface electronics. Please consult the EVM user guide prior to connecting any load to the EVM output. If there is uncertainty as to the load specification, please contact a TI field representative. During normal operation, even with the inputs and outputs kept within the specified allowable ranges, some circuit components may have elevated case temperatures. These components include but are not limited to linear regulators, switching transistors, pass transistors, current sense resistors, and heat sinks, which can be identified using the information in the associated documentation. When working with the EVM, please be aware that the EVM may become very warm.

4.3.2 EVMs are intended solely for use by technically qualified, professional electronics experts who are familiar with the dangers and application risks associated with handling electrical mechanical components, systems, and subsystems. User assumes all responsibility and liability for proper and safe handling and use of the EVM by User or its employees, affiliates, contractors or designees. User assumes all responsibility and liability to ensure that any interfaces (electronic and/or mechanical) between the EVM and any human body are designed with suitable isolation and means to safely limit accessible leakage currents to minimize the risk of electrical shock hazard. User assumes all responsibility and liability for any improper or unsafe handling or use of the EVM by User or its employees, affiliates, contractors or designees.

4.4 User assumes all responsibility and liability to determine whether the EVM is subject to any applicable international, federal, state, or local laws and regulations related to User's handling and use of the EVM and, if applicable, User assumes all responsibility and liability for compliance in all respects with such laws and regulations. User assumes all responsibility and liability for proper disposal and recycling of the EVM consistent with all applicable international, federal, state, and local requirements.

5. *Accuracy of Information:* To the extent TI provides information on the availability and function of EVMs, TI attempts to be as accurate as possible. However, TI does not warrant the accuracy of EVM descriptions, EVM availability or other information on its websites as accurate, complete, reliable, current, or error-free.

6. *Disclaimers:*
- 6.1 EXCEPT AS SET FORTH ABOVE, EVMS AND ANY WRITTEN DESIGN MATERIALS PROVIDED WITH THE EVM (AND THE DESIGN OF THE EVM ITSELF) ARE PROVIDED "AS IS" AND "WITH ALL FAULTS." TI DISCLAIMS ALL OTHER WARRANTIES, EXPRESS OR IMPLIED, REGARDING SUCH ITEMS, INCLUDING BUT NOT LIMITED TO ANY IMPLIED WARRANTIES OF MERCHANTABILITY OR FITNESS FOR A PARTICULAR PURPOSE OR NON-INFRINGEMENT OF ANY THIRD PARTY PATENTS, COPYRIGHTS, TRADE SECRETS OR OTHER INTELLECTUAL PROPERTY RIGHTS.
- 6.2 EXCEPT FOR THE LIMITED RIGHT TO USE THE EVM SET FORTH HEREIN, NOTHING IN THESE TERMS AND CONDITIONS SHALL BE CONSTRUED AS GRANTING OR CONFERRING ANY RIGHTS BY LICENSE, PATENT, OR ANY OTHER INDUSTRIAL OR INTELLECTUAL PROPERTY RIGHT OF TI, ITS SUPPLIERS/LICENSORS OR ANY OTHER THIRD PARTY, TO USE THE EVM IN ANY FINISHED END-USER OR READY-TO-USE FINAL PRODUCT, OR FOR ANY INVENTION, DISCOVERY OR IMPROVEMENT MADE, CONCEIVED OR ACQUIRED PRIOR TO OR AFTER DELIVERY OF THE EVM.
7. *USER'S INDEMNITY OBLIGATIONS AND REPRESENTATIONS.* USER WILL DEFEND, INDEMNIFY AND HOLD TI, ITS LICENSORS AND THEIR REPRESENTATIVES HARMLESS FROM AND AGAINST ANY AND ALL CLAIMS, DAMAGES, LOSSES, EXPENSES, COSTS AND LIABILITIES (COLLECTIVELY, "CLAIMS") ARISING OUT OF OR IN CONNECTION WITH ANY HANDLING OR USE OF THE EVM THAT IS NOT IN ACCORDANCE WITH THESE TERMS AND CONDITIONS. THIS OBLIGATION SHALL APPLY WHETHER CLAIMS ARISE UNDER STATUTE, REGULATION, OR THE LAW OF TORT, CONTRACT OR ANY OTHER LEGAL THEORY, AND EVEN IF THE EVM FAILS TO PERFORM AS DESCRIBED OR EXPECTED.
8. *Limitations on Damages and Liability:*
- 8.1 *General Limitations.* IN NO EVENT SHALL TI BE LIABLE FOR ANY SPECIAL, COLLATERAL, INDIRECT, PUNITIVE, INCIDENTAL, CONSEQUENTIAL, OR EXEMPLARY DAMAGES IN CONNECTION WITH OR ARISING OUT OF THESE TERMS AND CONDITIONS OR THE USE OF THE EVMS PROVIDED HEREUNDER, REGARDLESS OF WHETHER TI HAS BEEN ADVISED OF THE POSSIBILITY OF SUCH DAMAGES. EXCLUDED DAMAGES INCLUDE, BUT ARE NOT LIMITED TO, COST OF REMOVAL OR REINSTALLATION, ANCILLARY COSTS TO THE PROCUREMENT OF SUBSTITUTE GOODS OR SERVICES, RETESTING, OUTSIDE COMPUTER TIME, LABOR COSTS, LOSS OF GOODWILL, LOSS OF PROFITS, LOSS OF SAVINGS, LOSS OF USE, LOSS OF DATA, OR BUSINESS INTERRUPTION. NO CLAIM, SUIT OR ACTION SHALL BE BROUGHT AGAINST TI MORE THAN ONE YEAR AFTER THE RELATED CAUSE OF ACTION HAS OCCURRED.
- 8.2 *Specific Limitations.* IN NO EVENT SHALL TI'S AGGREGATE LIABILITY FROM ANY WARRANTY OR OTHER OBLIGATION ARISING OUT OF OR IN CONNECTION WITH THESE TERMS AND CONDITIONS, OR ANY USE OF ANY TI EVM PROVIDED HEREUNDER, EXCEED THE TOTAL AMOUNT PAID TO TI FOR THE PARTICULAR UNITS SOLD UNDER THESE TERMS AND CONDITIONS WITH RESPECT TO WHICH LOSSES OR DAMAGES ARE CLAIMED. THE EXISTENCE OF MORE THAN ONE CLAIM AGAINST THE PARTICULAR UNITS SOLD TO USER UNDER THESE TERMS AND CONDITIONS SHALL NOT ENLARGE OR EXTEND THIS LIMIT.
9. *Return Policy.* Except as otherwise provided, TI does not offer any refunds, returns, or exchanges. Furthermore, no return of EVM(s) will be accepted if the package has been opened and no return of the EVM(s) will be accepted if they are damaged or otherwise not in a resalable condition. If User feels it has been incorrectly charged for the EVM(s) it ordered or that delivery violates the applicable order, User should contact TI. All refunds will be made in full within thirty (30) working days from the return of the components(s), excluding any postage or packaging costs.
10. *Governing Law:* These terms and conditions shall be governed by and interpreted in accordance with the laws of the State of Texas, without reference to conflict-of-laws principles. User agrees that non-exclusive jurisdiction for any dispute arising out of or relating to these terms and conditions lies within courts located in the State of Texas and consents to venue in Dallas County, Texas. Notwithstanding the foregoing, any judgment may be enforced in any United States or foreign court, and TI may seek injunctive relief in any United States or foreign court.

Mailing Address: Texas Instruments, Post Office Box 655303, Dallas, Texas 75265
Copyright © 2015, Texas Instruments Incorporated

IMPORTANT NOTICE

Texas Instruments Incorporated and its subsidiaries (TI) reserve the right to make corrections, enhancements, improvements and other changes to its semiconductor products and services per JESD46, latest issue, and to discontinue any product or service per JESD48, latest issue. Buyers should obtain the latest relevant information before placing orders and should verify that such information is current and complete. All semiconductor products (also referred to herein as "components") are sold subject to TI's terms and conditions of sale supplied at the time of order acknowledgment.

TI warrants performance of its components to the specifications applicable at the time of sale, in accordance with the warranty in TI's terms and conditions of sale of semiconductor products. Testing and other quality control techniques are used to the extent TI deems necessary to support this warranty. Except where mandated by applicable law, testing of all parameters of each component is not necessarily performed.

TI assumes no liability for applications assistance or the design of Buyers' products. Buyers are responsible for their products and applications using TI components. To minimize the risks associated with Buyers' products and applications, Buyers should provide adequate design and operating safeguards.

TI does not warrant or represent that any license, either express or implied, is granted under any patent right, copyright, mask work right, or other intellectual property right relating to any combination, machine, or process in which TI components or services are used. Information published by TI regarding third-party products or services does not constitute a license to use such products or services or a warranty or endorsement thereof. Use of such information may require a license from a third party under the patents or other intellectual property of the third party, or a license from TI under the patents or other intellectual property of TI.

Reproduction of significant portions of TI information in TI data books or data sheets is permissible only if reproduction is without alteration and is accompanied by all associated warranties, conditions, limitations, and notices. TI is not responsible or liable for such altered documentation. Information of third parties may be subject to additional restrictions.

Resale of TI components or services with statements different from or beyond the parameters stated by TI for that component or service voids all express and any implied warranties for the associated TI component or service and is an unfair and deceptive business practice. TI is not responsible or liable for any such statements.

Buyer acknowledges and agrees that it is solely responsible for compliance with all legal, regulatory and safety-related requirements concerning its products, and any use of TI components in its applications, notwithstanding any applications-related information or support that may be provided by TI. Buyer represents and agrees that it has all the necessary expertise to create and implement safeguards which anticipate dangerous consequences of failures, monitor failures and their consequences, lessen the likelihood of failures that might cause harm and take appropriate remedial actions. Buyer will fully indemnify TI and its representatives against any damages arising out of the use of any TI components in safety-critical applications.

In some cases, TI components may be promoted specifically to facilitate safety-related applications. With such components, TI's goal is to help enable customers to design and create their own end-product solutions that meet applicable functional safety standards and requirements. Nonetheless, such components are subject to these terms.

No TI components are authorized for use in FDA Class III (or similar life-critical medical equipment) unless authorized officers of the parties have executed a special agreement specifically governing such use.

Only those TI components which TI has specifically designated as military grade or "enhanced plastic" are designed and intended for use in military/aerospace applications or environments. Buyer acknowledges and agrees that any military or aerospace use of TI components which have **not** been so designated is solely at the Buyer's risk, and that Buyer is solely responsible for compliance with all legal and regulatory requirements in connection with such use.

TI has specifically designated certain components as meeting ISO/TS16949 requirements, mainly for automotive use. In any case of use of non-designated products, TI will not be responsible for any failure to meet ISO/TS16949.

Products

Audio	www.ti.com/audio
Amplifiers	amplifier.ti.com
Data Converters	dataconverter.ti.com
DLP® Products	www.dlp.com
DSP	dsp.ti.com
Clocks and Timers	www.ti.com/clocks
Interface	interface.ti.com
Logic	logic.ti.com
Power Mgmt	power.ti.com
Microcontrollers	microcontroller.ti.com
RFID	www.ti-rfid.com
OMAP Applications Processors	www.ti.com/omap
Wireless Connectivity	www.ti.com/wirelessconnectivity

Applications

Automotive and Transportation	www.ti.com/automotive
Communications and Telecom	www.ti.com/communications
Computers and Peripherals	www.ti.com/computers
Consumer Electronics	www.ti.com/consumer-apps
Energy and Lighting	www.ti.com/energy
Industrial	www.ti.com/industrial
Medical	www.ti.com/medical
Security	www.ti.com/security
Space, Avionics and Defense	www.ti.com/space-avionics-defense
Video and Imaging	www.ti.com/video

TI E2E Community

e2e.ti.com